

CARVER

P R O F E S S I O N A L

PM-300 Magnetic Field Power Amplifier

OWNER'S MANUAL

IMPORTANT NOTICE
Please read carefully!

This amplifier was originally manufactured by Carver Corporation. There are references contained within this manual to addresses and telephone numbers that should no longer be used to obtain technical support or factory service.

For any assistance with this product please contact:

Carver Professional
A Division of Phoenix Gold International, Inc.
9300 North Decatur
Portland, Oregon 97203
Tel. 503.978.3344
Fax 503.978.3302

CARVER
P R O F E S S I O N A L

1. Safety Instructions

1. Read Instructions — All the safety and operation instructions should be read before the Carver Component is operated.

2. Retain Instructions — The safety and operating instructions should be kept for future reference.

3. Heed Warnings — All warnings on the Component and in these operating instructions should be followed.

4. Follow Instructions — All operating and other instructions should be followed.

5. Water and Moisture — The Component should not be used near water - for example, near a bathtub, washbowl, kitchen sink, laundry tub, in a wet basement, or near a swimming pool, etc.

6. Ventilation — The Component should be situated so that its location or position does not interfere with its proper ventilation. For example, the Component should not be situated on a bed, sofa, rug, or similar surface that may block any ventilation openings; or placed in a built-in installation such as a bookcase or cabinet that may impede the flow of air through ventilation openings.

7. Heat — The Component should be situated away from heat sources such as radiators, or other devices which produce heat.

8. Power Sources — The Component should be connected to a power supply only of the type described in these operation instructions or as marked on the Component.

9. Power Cord Protection — Power-supply cords should be routed so that they are not likely to be walked upon or pinched by items placed upon or against them, paying particular attention to cords at plugs, convenience receptacles, and the point where they exit the Component.

10. Cleaning — The Component should be cleaned only as recommended in this manual.

11. Non-use Periods— The power cord of the Component should be unplugged from the outlet when unused for a long period of time.

12. Object and Liquid Entry — Care should be taken so that objects do not fall into and liquids are not spilled into the inside of the Component.

13. Damage Requiring Service — The Component should be serviced only by qualified service personnel when:

- A. The power-supply cord or the plug has been damaged; or
- B. Objects have fallen, or liquid has spilled into the Component; or
- C. The Component has been exposed to rain; or
- D. The Component does not appear to operate normally or exhibits a marked change in performance;
or
- E. The Component has been dropped, or its cabinet damaged.

14. Servicing — The user should not attempt to service the Component beyond those means described in this operating manual. All other servicing should be referred to qualified service personnel.



CAUTION
RISK OF ELECTRIC SHOCK
DO NOT OPEN



**CAUTION: TO REDUCE THE RISK OF ELECTRIC SHOCK
DO NOT REMOVE COVER (OR BACK)
NO USER-SERVICEABLE PARTS INSIDE
REFER SERVICING TO QUALIFIED PERSONNEL**



The lightning flash with arrowhead symbol within an equilateral triangle is intended to alert the user to the presence of uninsulated "dangerous voltage" within the product's enclosure, that may be of sufficient magnitude to constitute a risk of electric shock to persons.



The exclamation point within an equilateral triangle is intended to alert the user of the presence of important operating and maintenance (servicing) instructions in the literature accompanying the appliance.

PORTABLE CART WARNING



Carts and stands - The Component should be used only with a cart or stand that is recommended by the manufacturer. A Component and cart combination should be moved with care. Quick stops, excessive force, and uneven surfaces may cause the Component and cart combination to overturn.

15. Grounding or Polarization — Precautions should be taken so that the grounding or polarization means of the Component is not defeated.

16. Internal/External Voltage Selectors — Internal or external line voltage selector switches, if any, should only be reset and re-equipped with a proper plug for alternate

voltage by a qualified service technician. See an Authorized Carver Dealer for more information.

17. Attachment Plugs for Alternate Line Voltage (Dual voltage models only) — See your Authorized Carver Dealer for information on the attachment plug for alternate voltage use. This pertains to dual-voltage units only.

**WARNING – TO REDUCE THE RISK OF FIRE OR ELECTRIC SHOCK,
DO NOT EXPOSE THIS APPLIANCE TO RAIN OR MOISTURE.**

1. Table of Contents

1. Introduction	4	5. Technical Information	11
About This Manual	4	Low Level Circuitry	11
Notational Conventions	4	Power Amplifier Circuitry	11
2. Special Features	5	Magnetic Field Power Supply	12
Magnetic Field Amplifiers	5	Start-up Sequence	12
Direct 70V Output Capability	5	Power Supply Regulation	12
Clipping Eliminator	5	Load Regulation	13
Protection Circuitry	5	Secondary Voltages	13
Specifications	6	Protection Circuitry	13
3. Front and Rear Panel Features	6	Over-Current and High Frequency	
Front Panel	6	Output Muting	13
Rear Panel	6	Clipping Eliminator Circuit	13
4. Installation	7	DC Offset	13
Mechanical Considerations	7	Overheated Output Transistors	14
Rear Support for Road Applications	7	Major Faults	14
Thermal Considerations	8	Display Circuit	14
AC Power Considerations	8	Series Mono Switching	14
Line Voltage Conversion	8	Schematic Diagrams	15-21
Magnetic Flux Leakage Considerations	8	6. In Case of Difficulty	22
I/O Wiring	8	No lights, no sound	22
XLR Connector Polarity (Pin 2 vs Pin 3)	8	Low Output or No Output	22
Changing XLR Connector Polarity	8	Distortion	22
Output Connector Wiring	9	Protection LEDs Illuminated	22
Ground Lift Strap	9	7. Warranty Information	23
Switch Settings	10		
Bridging Operation	10		
Clipping Eliminator	10		
Using the PM-300	10		

A Message from Bob Carver

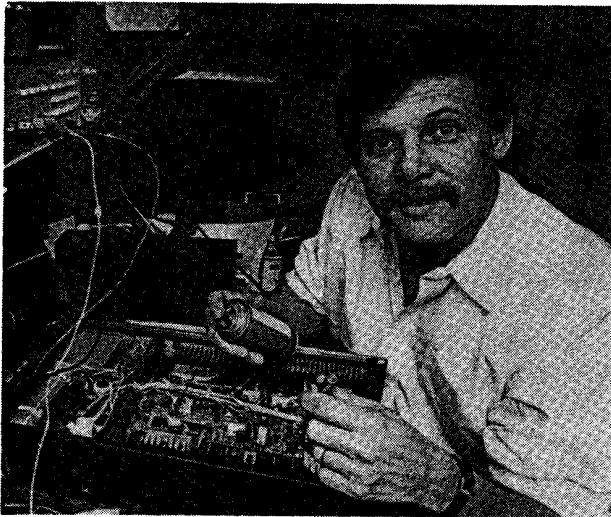

Congratulations on the purchase of your professional PM-300 Amplifier. It represents the latest technology in Carver's patented Magnetic Field Power Supply. This efficient supply, coupled with a unique amplifier design, provide you with the very best in performance. Because of the specially-designed protection systems, you can be assured your valuable speakers and amplifier will be protected.

Its lightweight and rugged construction makes it ideal for touring and permanent installations. We are proud of our track record for excellent performance and proven reliability. The high quality standards Carver products provide are the quality that our customers have come to expect.

Bob Carver
Chairman of the Board

1. Introduction

About This Manual

The manual is divided into the following sections:

Introduction — Introduces the PM-300 and describes the manual and the notational conventions used in the manual.

Special Features — Describes the features that make the PM-300 unique and lists the specifications.

Front and Rear Panel Features — Describes every knob, button, switch, and connector on the front and rear panels of the PM-300.

Installation — Covers all aspects of installation: mechanical, electrical, and thermal.

Technical Information — Describes the PM-300's circuit design. Includes schematic diagrams.

In Case of Difficulty — Describes what to do when the PM-300 won't operate.

Warranty Information — Tells what to do when you need to contact the factory for repair or repair parts.

Notational Conventions

Several notational conventions are used in this manual. Some paragraphs may use Note, Caution, or Warning as a heading. These headings have the following meaning:

Note — Identifies information that needs extra emphasis. A Note generally supplies extra information to help you use the amplifier more effectively.

Caution — Identifies information that, if not heeded, may cause damage to the amplifier or other equipment in your system.

Warning — Identifies information that, if ignored, may be hazardous to your health or that of others.

2. Special Features

The PM-300 has several design features that set it apart from the competition:

- Patented Magnetic Field Amplifier circuitry
- Clipping eliminator circuitry
- Protection circuitry

Magnetic Field Amplifiers

A Carver Magnetic Field Amplifier is the synergism of a highly-efficient, multiple-rail power amplifier and a regulated power supply. Using regulated power supplies for audio amplifiers is nothing new; the difference in the PM-300 is in the power transformer and how it is driven.

Conventional amplifiers require the power transformer to be energized 100% of the time that the amplifier is in use. A magnetic field amplifier's power transformer is inside a voltage regulator's feedback loop; it is only fully on when needed for full power output. At all other times, the power transformer operates only enough to keep the main filter capacitors charged to plus and minus 53 volts. This allows a considerable reduction in the size and weight of the power transformer; two of the principal reasons for the small size and light weight of the PM-300.

The amplifier circuitry uses a dual-rail power supply design. This design minimizes the voltage dropped across each of the output transistors, minimizing their heat dissipation. In turn, reduction of the heat dissipation allows reducing the size and bulk of the heat sinks used to transfer this heat to the surrounding air.

This combination of a magnetic field power supply and a high-efficiency output stage yields an amplifier with a high power to weight ratio.

Direct 70V Output Capability

In series bridging mode, the PM-300 can produce sufficient output voltage to drive 70-volt distribution systems without using a step-up transformer at the amplifier. The amplifier can deliver 150-watts to the 70-volt system. Transformers are still required at each loudspeaker (as is the case with all 70-volt systems).

Clipping Eliminator

In addition to sounding bad, clipped waveforms kill loudspeakers. This fact of life is made more true by the practice of using large amplifiers for increased headroom. When an amplifier clips, the output waveform contains large amounts of harmonics which extend both above and below the fundamental frequency. This can be potentially destructive to any high-frequency driver.

The clipping eliminator works by sensing any amplifier clipping and reducing the input signal level to limit the distortion in the output signal to less than one percent THD with up to 8 dB of overdrive. The action is similar to that of a limiter. The clipping eliminator is sensitive to clipping regardless of cause: excessive input drive, power line sag, low load impedances, etc.

Protection Circuitry

The PM-300 has specially designed protection circuitry that protects the amplifier from abnormal load conditions, as well as protecting the load from an abnormal amplifier. The amplifier includes the following protective measures:

- Input RFI filtering.
- Power line filtering.
- Load protection from excessive low-frequency or DC output.
- Amplifier protection from sustained current limiting caused by severe overdrive or abnormally low load impedances.
- Thermal overload protection.

The top two yellow LED indicators in the output display are illuminated when any of the protection circuits are activated or when the amplifier clips.

Specifications

Power Output	20-20kHz ..EIA
8 ohms, both ch driven	110W 125W
4 ohms, both ch driven	150W 170W
2 ohms, both ch driven	180W 210W
8 ohms series mono	300W 330W
16 ohms series mono	240W 280W
70V series mono	150W 150W

Note: 20-20kHz rating at 0.5% THD. EIA ratings are based on 1kHz sine wave, 0.5% THD.

Frequency Bandwidth	-3, +0 dB, 4Hz-70kHz
IM Distortion (SMPTE)	Less than 0.1%
Gain	26 dB
Input Sensitivity (full output)	1.5V RMS, +5.74 dBu
Input Impedance	30 Kilohms balanced
	15 Kilohms unbalanced (inverting "-")
	30 Kilohms unbalanced (non-inverting "+")
Input Overload	+15 dBu
Slew Rate	25 V/μSec
Damping Factor	100 @ 1 kHz
Output Noise (A weighted)	-95 dB, ref 28V output
EMI/RFI Noise Filtering	0.15-30 MHz normal mode and common mode
Inputs (balanced, differential)	XLR, 1/4 inch tip-ring-sleeve phone jack, barrier strip terminals
Dimensions (HxWxD)	1.75" x 19" x 13.25", 1U rack space.
	44mm x 483mm x 337mm
Net Weight	12 pounds (5.4 kg)
Shipping Weight	14.5 pounds (6.6 kg)
Power Consumption	850 Watts at full power into 8 ohms
	65 Watts at idle
Power Requirements	120 VAC/60Hz (USA and Canada)
	Other voltages as required for export

3. Front and Rear Panel Features

Front Panel

The following paragraphs describe the controls, switches, jacks, and displays found on the front panel of the PM-300. Refer to Figure 1.

1. POWER switch. Switch to the ON position to activate the amplifier. The inputs are muted for about 2 seconds to allow the power supply to stabilize and prevent turn-on thumps.

2. LEFT and RIGHT level controls. 11-step attenuators that adjust the relative output level of the PM-300. The amount of attenuation corresponds to the front-panel marking, in dB.

3. PHONES jack. A tip-ring-sleeve jack intended for use with stereo headphones. The tip connection of the jack connects to the left amplifier channel.

4. LED Output Status Display. 6 LEDs (per channel) indicating the status of the amplifier. The bottom, green LEDs indicate power-on. The four, red LEDs indicate the output power level of the amplifier in dB relative to maximum output. The top, yellow LEDs indicate the onset of clipping or the activation of the amplifier's protection circuits.

Rear Panel

The following paragraphs describe the various rear panel features of the PM-300. Refer to Figure 2.

1. INPUTS. Barrier strip terminals, female XLR connectors and 1/4 inch tip-ring-sleeve phone jacks. These are the input connectors for the amplifier.

2. SERIES MONO. Pressing this switch sets the PM-300 for bridged-mono operation. Use this mode for 8 ohm or greater loads, and for 70 V direct operation.

3. CLIPPING ELIMINATOR. Pressing this switch turns on the clipping eliminator circuit. In this mode, the amplifier output remains undistorted even when overdriven by up to 8 dB.

4. AMPLIFIER/CHASSIS Ground Terminal. Removing this jumper isolates the amplifier's power supply ground from the amplifier chassis.

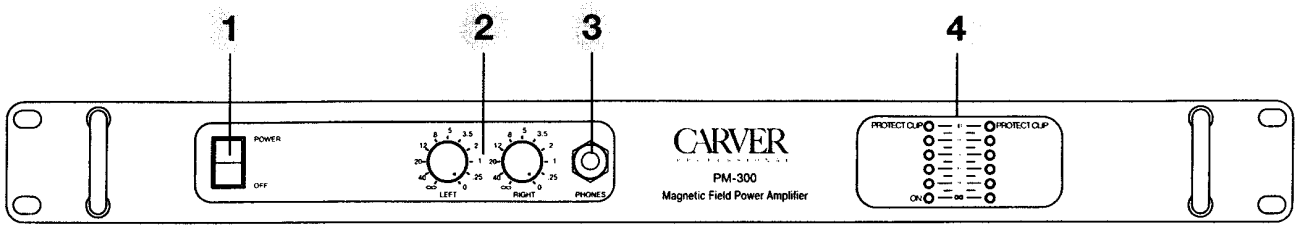

Fig. 1

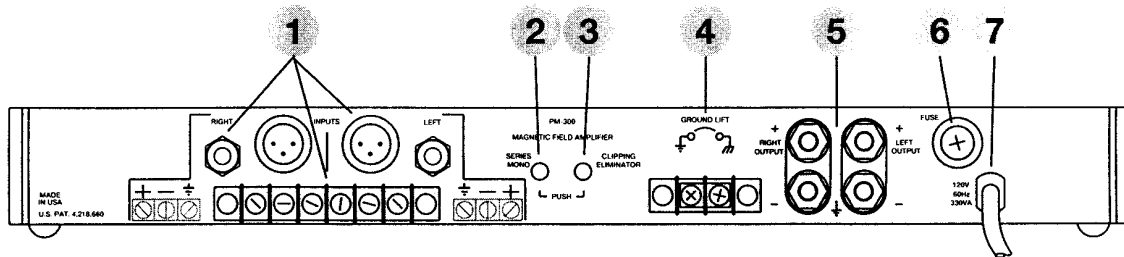

Fig. 2

This may be necessary to eliminate ground loops in some systems. The amplifier chassis is always connected to the safety ground (line plug ground or green wire) of the power cord. With the jumper removed, the amplifier's circuit ground is connected to the amplifier's chassis ground via a 27-kilohm resistor in parallel with a 0.1 μ F capacitor.

CANADIAN MODEL ONLY: The potential difference between these two terminals is always limited to less than 4 volts, regardless of how external circuits are connected.

5. LEFT/RIGHT SPEAKER OUTPUT.

5-way binding posts used to connect the loudspeakers to the amplifier outputs. The red terminal is the signal connection, the black terminal is the signal return connection. The black terminals are internally connected together.

6. FUSE. AC power line fuse for the PM-300. Use only type MDQ7, 7 ampere slow-blow. Repeated fuse blowing is a sign of internal distress. Have an authorized Carver service technician repair the amplifier.

7. POWER CORD. Connect to a properly configured outlet providing the line voltage specified for your model.

4. Installation

The PM-300 may be used free-standing or installed inside a rack enclosure. Installation consists of the actual mechanical installation, and the electrical and thermal considerations needed. These considerations are detailed in the following paragraphs.

Mechanical Considerations

The PM-300 requires one rack space (1.75 inches). The amplifier requires 13.25 inches depth inside the rack. Be sure to secure the unit mechanically using four screws. It is a good idea to use flat-washers with the screws to prevent marring the front panel. Be sure that there is sufficient air space at the sides of the amplifier for airflow around the heat sinks.

Rear Support for Road Applications

If the PM-300 is rack-mounted, and the rack transported, it is good practice to provide mechanical support for the rear of the amplifier. This could take the form of a shelf across the rear of the amplifier, or brackets that engage the rear of the unit. This practice is recommended for all rack-mounted electronic instruments; especially those that are large, heavy, or mechanically deep. Note: In most rack-mount applications, the rubber "feet" will need to be removed from the PM-300.

PM-300

Thermal Considerations

When the PM-300 is used free-standing, there are no thermal considerations to be made. If the PM-300 is rack mounted, ensure that adequate ventilation exists on each side of the amplifier. When several amplifiers are mounted together in a rack, you may need to provide air inlets from the outside of the rack. In most cases, convection cooling is sufficient. However, in high ambient temperatures, forced-air cooling may be needed.

PM-300s may be stacked directly on top of each other without spacer panels. However, if the amplifier is used with other amplifiers, you should ensure that the other amplifier's heat output doesn't become part of the PM-300's cold air supply. In this case, additional cooling (fans) may be required.

AC Power Considerations

Ensure that the PM-300 is plugged into an outlet capable of supplying the correct voltage specified for your model and enough current to allow full-power operation of all the amplifiers plugged into it.

Line Voltage Conversion

Caution

The line voltage conversion process requires soldering and the services of a competent technician. Please refer the unit to an authorized Carver Service Facility for conversion.

Magnetic Flux Leakage Considerations

The PM-300 may be mounted without concern for magnetic flux leakage, within the confines of common sense. For example, it's not a good idea to mount any power amplifier near a microphone input transformer or magnetic storage media.

I/O Wiring

The PM-300 has three types of input connections (in order of reliability): screw terminals, XLR female, and 1/4 inch tip-ring-sleeve phone jack. Use the connector most appropriate to your installation. For fixed installations, we recommend using the screw terminals with suitable crimp-on lugs attached to the wire.

In addition, a ground system strap allows isolating the amplifier circuit ground from the AC line safety ground (green wire). Isolating the grounds may be necessary in some installations to break a ground loop. This is infinitely preferable to breaking the ground pin off the power cord.

FOR CANADIAN MODELS: The difference in ground potential is always limited to less than 4 volts regardless of external connections.

XLR Connector Polarity (Pin 2 vs Pin 3)

The PM-300's XLR connector may be wired for either Pin 2 hot or Pin 3 hot. The XLRs are supplied from the factory with Pin 3 hot (+). An internal slide switch determines the configuration.

Note

The XLR connector polarity does not affect the polarity of the phone jack or the screw terminals. The hot pin of the XLR corresponds to the tip connection on the TRS phone jack. The input connectors are connected in parallel; you can parallel the amplifier inputs by patching an unused input connector to its counterpart on the other channel.

Changing XLR connector polarity (Pin 2 vs Pin 3)

Use the following procedure to change the polarity of the XLR connector.

1. Disconnect the amplifier from the source of AC power.
2. Remove the PM-300's outer cover.
3. Locate the polarity-setting slide switch directly behind the input sockets.
4. Set the switch to "+2" position for Pin 2 hot, or "+3" position for Pin 3 hot.
5. Replace the outer cover.

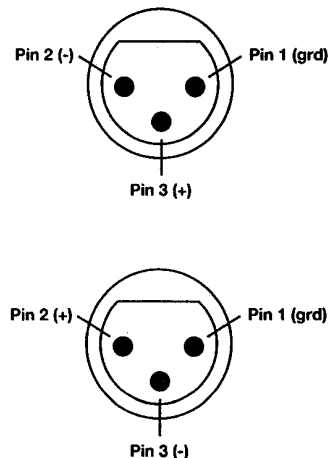

Fig. 3

Fig. 4

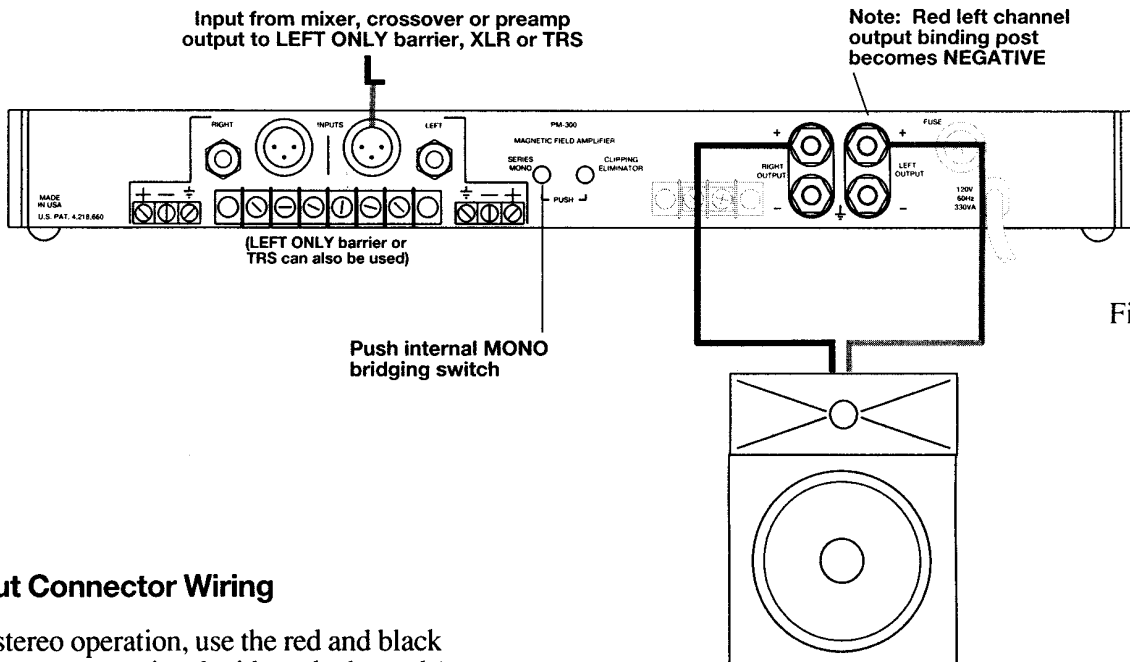
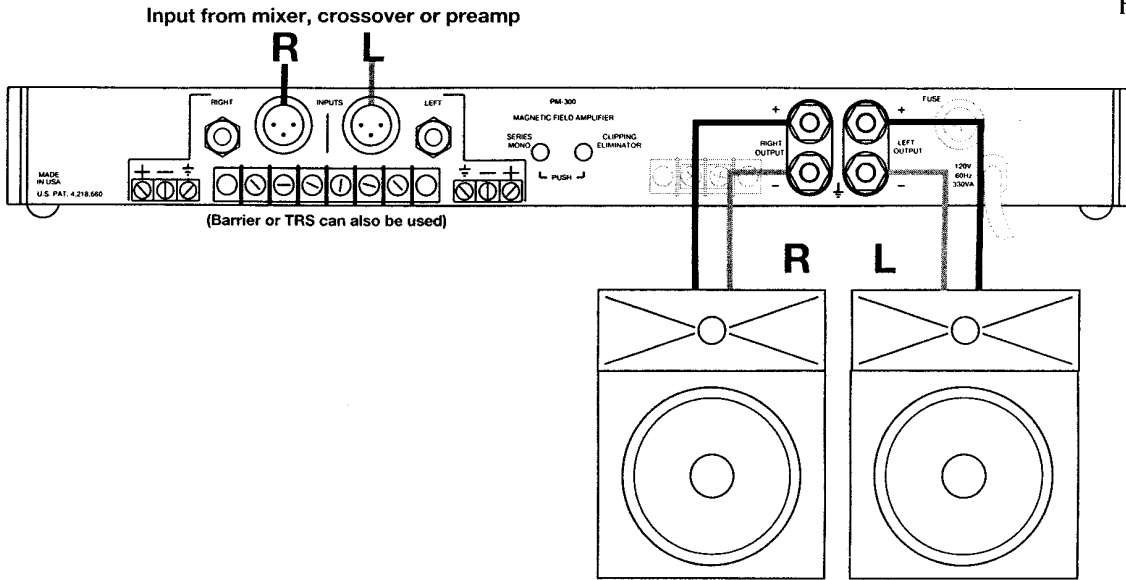

Fig.5

Output Connector Wiring

For stereo operation, use the red and black binding posts associated with each channel (see Figure 4).

For bridged-mono operation, use both red binding posts (see Figure 5). The right-channel red post is the 'hot' side (non-inverting) and the left-channel red post is the 'low' side (inverting).

In either case, ensure that the total load impedance is not lower than that listed in the specifications for the mode of operation that you have selected.

Ground Lift Strap

The ground lift strap is located on the rear chassis of the amplifier, near the speaker output binding posts. To break the link between the amplifier's circuit ground and the amplifier chassis, remove the metal link that connects the two terminals. In most cases, the PM-300 operates best (lowest noise) with the linking installed.

CANADIAN MODELS: An internal auto-isolator circuit limits the potential difference between ground terminals to less than 4 volts regardless of external circuit connections. This is done to conform with Canadian safety regulations.

Warning: For safety reasons, do not separate the ground systems unless absolutely necessary.

Switch Settings

The PM-300 has two switches on the rear panel that control various aspects of its operation.

Bridging Operation. One switch, located on the rear panel of the PM-300, enables bridging mode for the amplifier.

For stereo operation, use the INPUT connectors and OUTPUT connectors associated with each channel. For bridged-mono operation, use the LEFT INPUT connector, and both red OUTPUT connections. The RIGHT output is the signal (non-inverting "+") connection, the LEFT output is the (inverting "-") connection.

Note

Be sure to set both of the input level controls to the exact same setting for equal power distribution per channel.

Note

In bridged-mono operation, the output connections are actually a balanced output configuration. This means that neither output terminal may be grounded (both are "hot").

Caution

We do not recommend using phone plugs for speaker connections, especially with a bridged-mono amplifier. If you must use phone plugs for speaker cables, beware! When connected to a bridged-mono amplifier, the shell of the plug is 'hot' and could cause a nasty surprise if it comes in contact with something or someone that is grounded. At a minimum, insulate the shell of the plug with shrink sleeving.

Clipping Eliminator. The CLIPPING ELIMINATOR switch turns on the anti-clipping feature of the PM-300. When the switch is pressed, input signals that are large enough to drive the amplifier output past clipping are reduced enough to keep the amplifier from clipping. The clipping

eliminator circuit keeps the amplifier output below one percent THD at up to 8 dB of overdrive.

Note

If the input LEVEL control(s) are turned down far enough, a sufficiently large input signal could drive the input differential amplifier into clipping. Another possibility is that the mixer, equalizer, etc. that is driving the amplifier may not have sufficient output to overcome the loss introduced by the setting of the input LEVEL control(s). The CLIPPING ELIMINATOR switch has no effect on these causes of clipping.

Using the PM-300

Once the amplifier has been installed and wired into your system, you are ready to use it. Here are some tips to help you get the most from your PM-300.

- Check the switch settings on the rear panel. Be sure that the mono-mode switch conforms to the actual mode that you want.
- Use the clipping-eliminator feature. It helps save your loudspeakers from damage.
- Be sure that the input LEVEL controls are set sufficiently high to allow the preceding device in your system to drive the amplifier to full output. For most installations, the LEVEL controls are set fully clockwise.
- When you power the system up for the first time (out of the carton), it's a good idea to start with all of the amplifier level controls off, then advance them slowly, one at a time, so that you can determine that each amplifier channel is operating normally.
- Once you have established settings, it is a good idea to mark them down, on paper, on pieces of tape, or sticky-dots attached to the amplifier's front panel.
- In bi-amplified (all multi-amp) systems, it is a good idea to start with the low-frequency amplifiers turned off or down, and to check each frequency range from highest to lowest to ensure that the proper loudspeaker components are reproducing it.
- You can use the PHONES jack to quickly check the amplifier during operation. Simply plug in a pair of headphones to listen to the amplifier output.

5. Technical Information

This section discusses the theory of operation of the PM-300. For a better understanding of the circuitry involved, refer to the schematic diagrams presented later in this manual. Op-amps described in the circuitry use the following notation: U1(7) means U1, whose output appears on pin 7. Unless otherwise noted, this discussion centers around the left-channel circuitry. The right-channel circuitry is essentially identical.

Low Level Circuitry

Input signals enter the circuit via the rear-panel XLR connector, tip-ring-sleeve (TRS) phone jack, or screw terminal connections. S3 allows the polarity of the XLR connector to be configured for pin 3 hot or pin 2 hot. As supplied from the factory, the PM-300 is configured for pin 3 hot. The switch setting does not affect the wiring of the TRS jack (tip=hot) or the screw terminal connections.

U4(1) is configured as a unity gain differential amplifier driving the left-channel level control. R36, R30, and U3 form an attenuator whose loss is dependent on the resistance of U3, an LED-LDR module. The drive for the LED portion of U3 comes from the clipping eliminator circuitry, which will be discussed later on. The signal then enters the mono-mode switching.

The PM-300 may be configured to operate as a conventional 2-channel, stereo amplifier, or as a single-channel, mono amplifier with high-voltage output. The operational mode is determined by switch S2. For now, assume that S2 is set for 2-channel, stereo operation.

Power Amplifier Circuitry

The PM-300 uses the patented Carver Magnetic Field power amplifier circuitry. This innovative circuit uses the combination of a smart power supply and a highly linear, dual-rail power amplifier circuit.

U1(7) is the input stage, providing differential inputs for input and feedback connections as well as most of the open-loop voltage gain of the

circuit. Overall negative feedback from the output stage via R20 and R16 sets the closed-loop gain at 26 dB. The output of U1(7) drives Q9 and Q12, operating as common emitters that level-shift the drive signal and couple it to the pre-driver amplifiers Q6 and Q8. Q6 and Q8 provide additional voltage gain, and when combined with the voltage gain of the input op-amp is sufficient to swing the input signal between the $\pm 53\text{V}$ power supply rails. Q7 and Q12 are connected as an NPN-PNP conjugate pair and used as a V_{BE} multiplier for bias control. Q7 is thermally connected to the output transistors and together with Q12 provides bias stabilization over a wide temperature range. RP1 allows the bias current to be adjusted to its optimum value.

Up to now, the amplifier circuitry has been fairly conventional. From this point on, there is a marked departure from convention.

The positive-going portion of the output stage is comprised of two series-connected NPN darlington emitter-followers (Q1/Q10, Q2/Q11). The negative-going portion of the output stage is exactly complementary to the positive-going portion; two series-connected PNP darlington, emitter-followers (Q3/Q13, Q4/Q14).

The innermost pairs (Q2/Q11, Q3/Q13) are driven from the opposite sides of the V_{BE} multiplier (Q7/Q12), which looks suspiciously like a full-complementary amplifier and is exactly that.

Q5 operates as a VI limiter, sensing the voltage drop across emitter resistor R1, and reducing the drive signal to the output stage under overload conditions (see section on Over-Current Protection further on).

The outermost pairs of output transistors (Q1/Q10, Q4/Q14) are driven from the output terminal of the amplifier via zener diodes D2 and D13, that level shifts the output signal by the zener voltage towards the $+53\text{V}$ power supply rail. As long as the peak AC output voltage remains below the zener voltage, Q10 and Q14 do not conduct. Once the AC output signal exceeds the zener voltage, the outermost output transistors begin to conduct. Diodes D6 and D7 are commutator diodes that disconnect the output stage from the 23V power supply whenever the voltage at the connection point between Q1/Q2 or Q3/Q4 exceeds 23V. Under high-frequency conditions, C9 and C12 provide phase lead for the outermost output transistors, ensuring that they can “stay ahead” of the audio signal.

Under small-signal conditions, the innermost pairs of transistors do all the work. As the signal level grows larger and larger, the outermost pairs of transistors assume part of the burden of providing a higher-voltage output signal to the load. This two-stage approach minimizes the voltage across each of the output devices which also minimizes the power dissipation required. Without this approach, the output transistors would be required to support the entire power supply voltage under small-signal conditions and the "unused" portion of the power supply voltage would be turned into heat.

Magnetic Field Power Supply

The main power supply for the PM-300 is a dual-voltage design which provides no-load voltages of ± 53 and ± 23 volts DC. Triac Q7 drives the primary of the magnetic field power transformer. Q7 operates as a phase controlled switch; its gate signal depends on the signal supplied to opto-isolator U2, which isolates the drive circuitry from the AC power line. Diode bridge D11 through D14 provides steering for the phototransistor in U2, allowing the triac to fire on both alternations of the power line.

Start-up Sequence

The phase shift voltage at the junction of R44 and R45 is obtained through the heatsink thermal switches and is approximately 110-120V, regardless of whether the amplifier is configured for 115V or 230V operation.

When the power switch on the front of the amplifier is turned on, capacitor C13 begins charging up through R45 and either Q3 or Q5, depending on the polarity. The positive half-cycle of the AC line will charge C13 through R45 and Q3. This charging current forward biases the base emitter junction of Q3, causing it to conduct. Q3 turns on Q4, but no gate current can flow because D17 is reverse biased. C13 continues charging until the charge on C13 exceeds the now falling voltage at the junction of the bases of Q3 and Q5, formed by divider R45 and R46. Q3 and Q4 will turn off and C13 will begin to discharge through Q5 because the junction of R45 and R46 is more negative than the emitter of Q5 (C13). Q5 will conduct and turn on Q6, and gate

current will flow through forward biased D18, firing and latching the triac. On the negative half cycle, C13 is charged through Q5 and discharged through Q3, Q4, D17 and R47 into the gate of the triac. The triac begins to conduct at a minimum phase angle and applies 30-40 VAC to the primary of the transformer.

The triac is switched on and off every half-cycle of the 60Hz AC line. Thus, the triac switches the AC line current off at a rate twice the line frequency, at the instant the line current crosses the zero axis. The triac will then remain off for a number of degrees of the sinusoid, before switching on again. The phase angle at which the triac switches on is the "firing angle" of the triac.

This produces enough voltage to the primary of the power transformer to allow the secondary regulator stage on the power supply board to begin to operate.

Power Supply Regulation

The firing angle of the triac controls the voltage on the primary of the transformer, and is determined by the conduction of the optocoupler U2 on the Power Supply Board.

As the conduction of the optocoupler increases, the amount of phase shift on C13 decreases, which increases the conduction angle of the triac. The phototransistor conduction of the optocoupler is controlled by the current through the LED portion of the optocoupler. When the LED in U2 is fully ON, the triac conducts earliest in the AC cycle: the power supply is operating at maximum output. The LED current is supplied by U1-7 on the power supply board. This differential amplifier senses the secondary supply voltages through R11, R12, R13 and R16. The output voltage at U1-7 increases at the rate determined by C9 (slow start-up). The phototransistor in the optocoupler will begin to conduct and charge C13 at a faster rate through R44 and D13/D11 or D14/D12 "steering" diodes, depending on the polarity. This decrease in phase shift results in a longer triac conduction time and higher secondary voltages. The idle secondary voltages are set by RP1 on the power supply board.

Load Regulation

When the amplifier is driven into a load, the DC supplies (rail voltages) will begin to “sag”. Differential amplifier U1-7 senses this and increases the LED current to the optocoupler. This action increases the phototransistor conduction, which increases the triac conduction, which increases the primary voltage, which increases the secondary voltages, thus providing steady, regulated DC supplies for the amplifier stage.

Secondary Voltages

The secondary winding of the power transformer has two taps that supply the two pairs of DC supply voltages ($\pm 53\text{V}$, $\pm 23\text{V}$), each having its own bridge rectifier and filter capacitors.

Load resistor R52 on the 23V bridge rectifier insures that the triac remains latched by providing primary holding current during the time when the secondary supply rectifiers normally stop conducting.

The $\pm 11.4\text{Vdc}$ supply is referenced to the $\pm 23\text{Vdc}$ supply, drawn from the $\pm 53\text{Vdc}$ supply, and regulated by Q1, Q2 and zener diodes D1 and D2. Resistors R2, R5, R3 and R4 provide a residual DC voltage after the unit is turned off, thus keeping the front end of each amplifier biased up to prevent excessive thumping. The $\pm 11.4\text{Vdc}$ supply powers the op-amps and small-signal transistors.

Protection Circuitry

Protection functions are shared by the amplifiers and the power supply. Active shutdown protection is provided for the following faults.

Over-Current and High Frequency Output Muting

The amplifiers are protected from short-term excess current through the output stage by electronic current-limiters. When the current through the output transistors becomes excessive, the voltage drop across the emitter resistors R1 and R2 bias the current limiter transistors Q5 and Q9 on, which shunt the drive current via D9 and D14. Q5 provides base current for Q14 on the Input Board through D10 and R26, which drives Q8. When Q8 turns on, C19 discharges and turns off Q7, which in turn activates the N-channel

muting FET Q2 on the Input Board (the FET is off with -DCV on the gate, and turns on with 0VDC). This attenuates the input signal, removing the high current condition. The input remains muted as C19 charges through R33/R53, which takes about 2 seconds. R24, D8, R36 and D15 on the Amplifier Board determine the V-I limits.

As the frequency increases, C6 on the Amplifier Board causes Q5 to bias on sooner, providing a measure of protection against excessive high frequency content or high frequency oscillation. Q9 operates in similar fashion for the negative-portion of the output stage.

Q14 also biases on Q10, lighting the Protect/Clip LED. C20 is charged and continues to provide a negative voltage to the display board, keeping the LED lit during the mute time.

The inputs are also muted for about 2 seconds when the amplifier is first switched on.

Clipping Eliminator Circuit

This circuit is controlled by the LED/LDR opto-isolator U3, located on the Input Board. The LED portion of this component is driven from a bridge rectifier (D12/D14, D11/D16) that gets its input signal from U1(7) on the Input Board. Under normal conditions (undistorted amplifier output) there is almost no signal at this point. If the amplifier is driven into clipping, the signal level at U1(7) rises rapidly because the feedback signal no longer represents the input signal. Once this occurs, the LED in U3 illuminates, reducing the resistance of the LDR portion which in turn reduces the input signal. The clipping-eliminator circuit is activated by switch S1 on the Input Board (accessed from the rear panel). When the switch is off, the signal driving the bridge rectifier is shorted to ground.

DC Offset

DC offset is sensed by a low-pass differential amplifier located on the power supply board, formed by U1-pins 2 and 3. Left and right amplifier outputs are summed by R31 and R33, and capacitor C8 rolls off the output in the audio spectrum while +/- DC offset and single channel low frequency signals below 5 Hz are amplified. If pin 1 goes positive, current through D10, R26, and U1-6 drives the output of U1-7 negative. This reverse biases the optocoupler LED on the

Regulator Board and forces the conduction angle of the triac back to its initial startup position, thereby lowering all secondary power supply voltages and insuring the offset is held to a minimum value.

Overheated Output Transistors

A 100° C resettable thermal switch is mounted on each heatsink in series with the AC line, which protects the output transistors if the top cover vents are blocked or if the unit is run with excessive continuous sinewaves.

Major Faults

The slo-blo line fuse protects the unit from further damage when a major fault such as a shorted triac, shorted output transistor, or a major secondary power supply fault occurs.

If the unit is run at or near its rated power, the fuse will eventually blow. The rated line fuse allows the unit to be operated without interruption for all musical applications.

Display Circuit

The clipping indicators are driven by comparators U1(3) and U2(12). The LEDs illuminate any time that the voltage at the non-inverting inputs of the comparators falls below (negative with respect to ground) the threshold set by the voltage divider (R1 and R2, R3 and R4) at the inverting inputs. The comparators get their inputs from several sources via diode OR gates:

- 1) The outputs of U1(1) and U1(7) on the Input Board. These signals indicate amplifier clipping.
- 2) The output of Q10 or Q3 on the Input Board. This signal goes negative any time that the high frequency or current limit protection circuits are activated.

The display driver circuit comprised of U1(4,12,10) and U2(10,3,4) is basically a ladder comparator driving LED's, with a twist. Assume that the signal at U1(5) is zero volts and ignore R12 and D3 for now. R7 and R8 are a voltage

divider that establishes a reference voltage for the comparators (three per channel). The comparators compare their input signal against the voltages established by the tapped voltage divider made up of R10, R9 and R11. The left channel LEDs are in the following sequence (lowest to highest): D8 (green), D6 (red), D7 (red), D5 (red), D4 (red), D1 (yellow).

The display board receives a positive-going half-wave rectified and smoothed signal from the Power Supply PCB. With the input signal at zero volts, all of the comparator outputs are at -12V. None of the LEDs (D4-D7) have any voltage across them; all are extinguished. As the input signal rises, it crosses, in sequence, the thresholds established at each of the three comparators. First U1(4) fires; its output goes high, and D6 illuminates. Next U1(12) fires, its output goes high; D6 extinguishes (no net voltage across it) and D7 illuminates. Finally U1(10) fires; D7 extinguishes, and (this is the twist) D3/R12 supply current to the bottom of the R10, R9 and R11 voltage divider, which inverts the relationship of the comparators to each other.

Once U1(10) fires, the current through R12 reverses the sequence of the voltages that establish the thresholds for the three comparators. This allows the same comparators to perform double-duty. The new thresholds leave U1(10) high, U1(12) and U1(4) low. D5 illuminates and D7 is reverse biased so it can't illuminate. As the input signal rises further, U1(12) fires, extinguishing D5 and illuminating D4.

Series Mono Switching

The series mono switch (S2 located on the Input Board and accessed from the rear panel) inserts a 180° phase inversion stage, U5(1), into the left channel. The series mono switch also connects the right channel drive to the left channel non-inverting stage U5(7). This allows both channels to be driven by the left channel input.

Schematic Diagrams

CAUTION

These servicing instructions are for use by qualified personnel only. To avoid electric shock do not perform any servicing other than that contained in the Operating Instructions unless you are qualified to do so.
Refer all servicing to qualified service personnel.

REV. NO.	605-00418-01	REV. NO.	Z
DATE	REV.	DESCRIPTION	REVISION
		SEE SHEET ONE	

CARVER	
REV. NO.	605-00418-01
DATE	REV. NO.
	REV. NO.

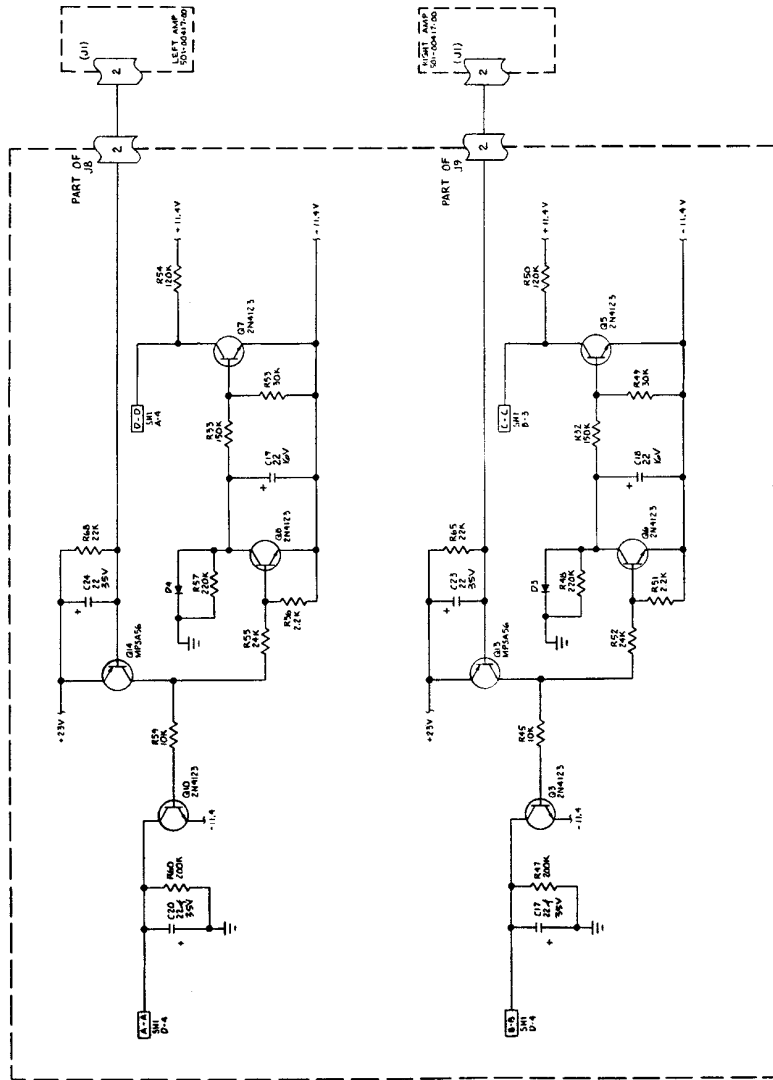

REV	DATE	DESCRIPTION
1	11-1-68	RELEASED TO PRODUCTION
2	1-1-69	COORD. BY
3	1-1-69	INDIC. PER. EGD

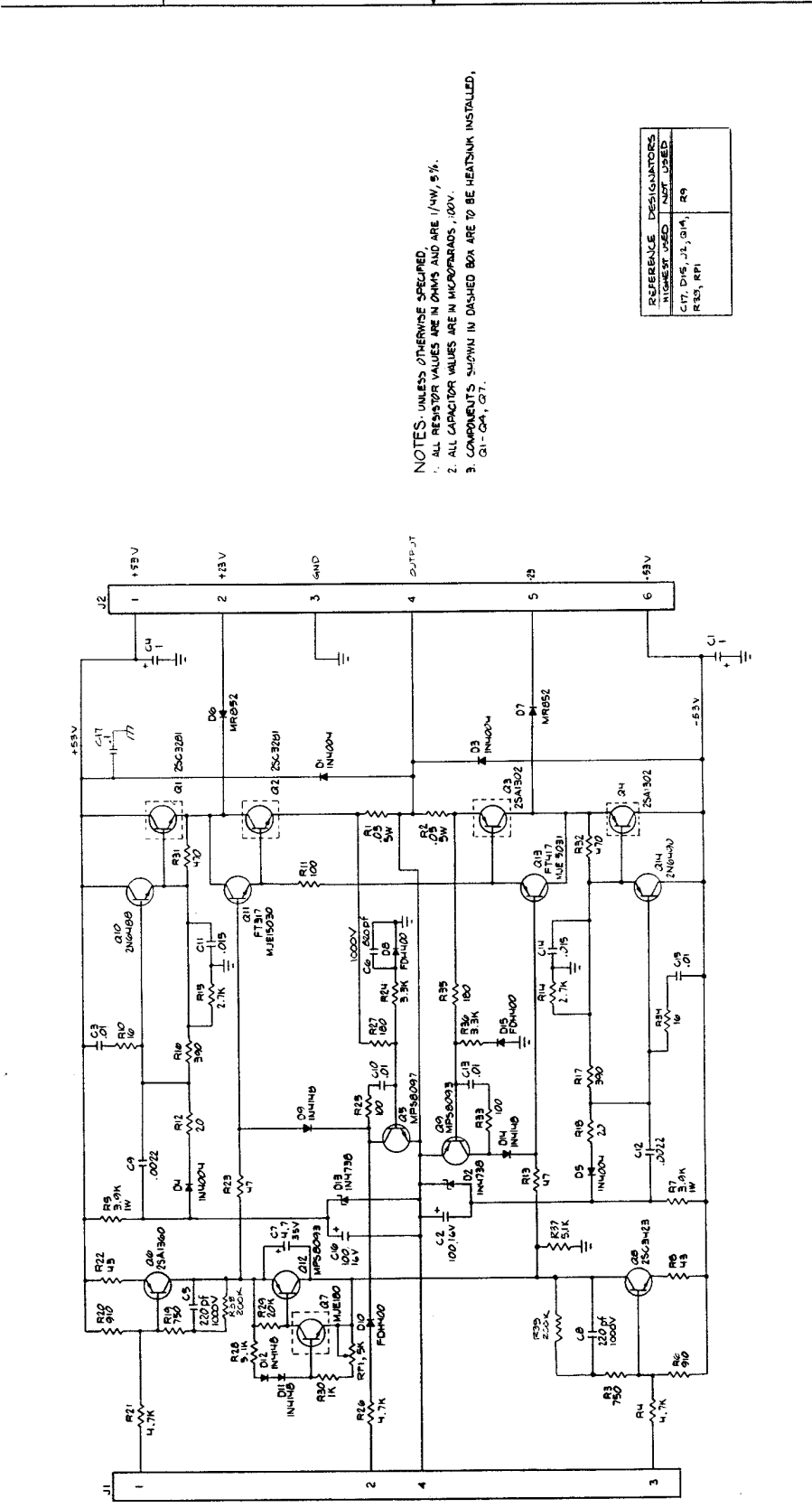

NOTES: UNLESS OTHERWISE SPECIFIED,
 1. ALL RESISTOR VALUES ARE IN OHMS AND ARE 1/4W, 5%.
 2. ALL CAPACITOR VALUES ARE IN MICROFARADS, .00V.
 3. COMPONENTS SHOWN IN DASHED BOX ARE TO BE HEATSINK INSTALLED,
 Q1-Q4, Q7.

REFERENCE DESIGNATORS	IN LARGEST USED	NOT USED
C17, D16, J2, Q14, R9		
R25, R21		

CARVER

SCHEMATIC DIAGRAM -
AMP PM-300

CONTRACT NO.	DATE	REV.	1
PROJECT NO.	10-17-68	REV.	1
DESIGNER	J. EDWARDS	DATE	10-17-68
CHECKED		DATE	
APPROVED		DATE	

DO NOT SCALE DRAWING

SCALE: NONE

SHEET 1 OF 1

FORM NO.	605-XX-416-00	REV.	H
DATE	APPROVED	DATE	APPROVED
1		2/17/60	
2		2/17/60	
3		2/17/60	
4		2/17/60	
5		2/17/60	
6		2/17/60	
7		2/17/60	
8		2/17/60	
9		2/17/60	
10		2/17/60	
11		2/17/60	
12		2/17/60	
13		2/17/60	
14		2/17/60	
15		2/17/60	
16		2/17/60	
17		2/17/60	
18		2/17/60	
19		2/17/60	
20		2/17/60	

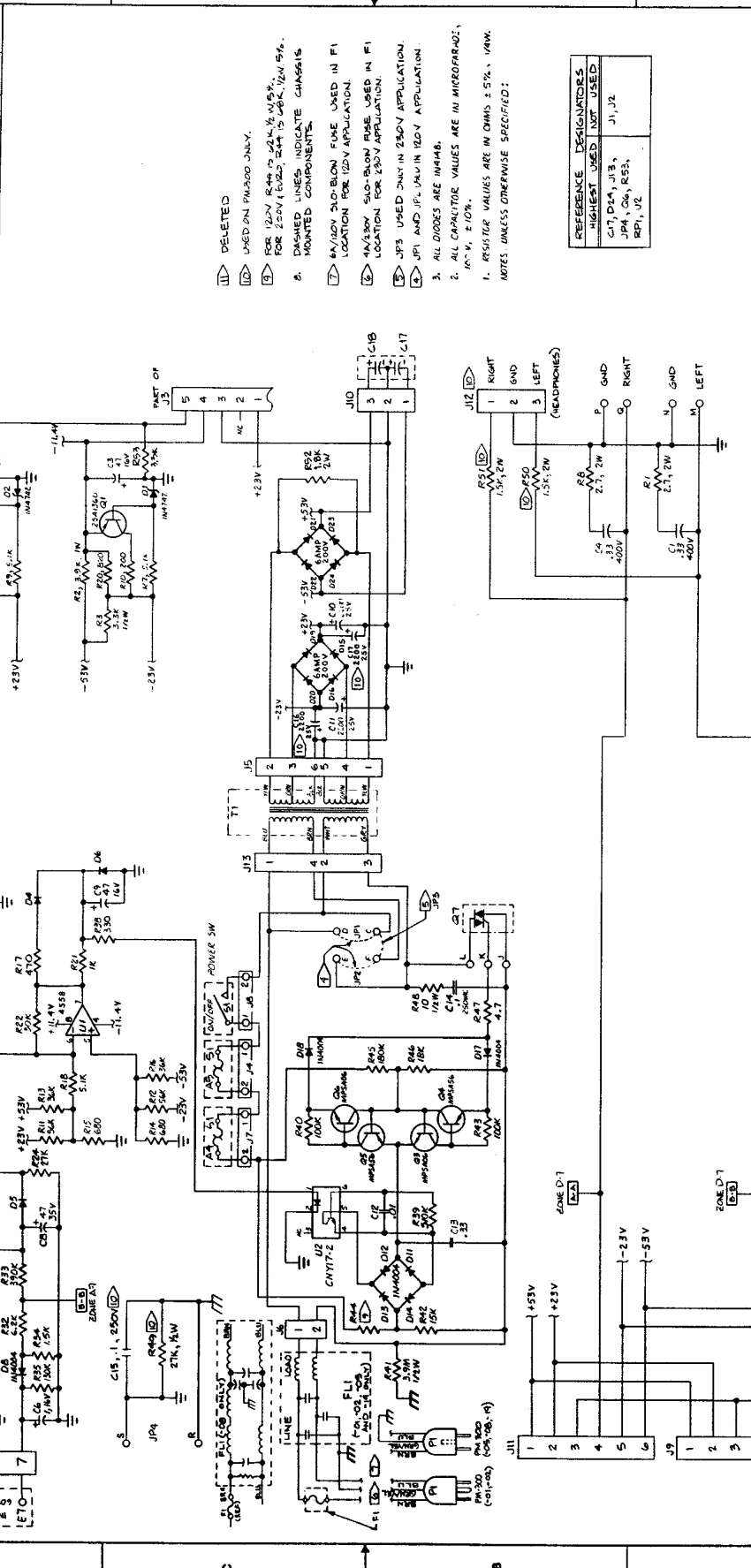

FORM NO.	605-XX-416-00	REV.	H
DATE	APPROVED	DATE	APPROVED
1		2/17/60	
2		2/17/60	
3		2/17/60	
4		2/17/60	
5		2/17/60	
6		2/17/60	
7		2/17/60	
8		2/17/60	
9		2/17/60	
10		2/17/60	
11		2/17/60	
12		2/17/60	
13		2/17/60	
14		2/17/60	
15		2/17/60	
16		2/17/60	
17		2/17/60	
18		2/17/60	
19		2/17/60	
20		2/17/60	

- 1. DELETED
- 2. USED ON PM300 ONLY.
- 3. FOR 120V USE IN 220V APPLICATION.
- 4. FOR 230V (EUC), 240V (UK), 250V (5%), 260V (5%).
- 5. DASHED LINES INDICATE CHANGES.
- 6. MOUNTED COMPONENTS.
- 7. 4A/100V 50-DIOLON FUSE USED IN F1 LOCATION FOR 120V APPLICATION.
- 8. 4A/250V 50-DIOLON FUSE USED IN F1 LOCATION FOR 230V APPLICATION.
- 9. JPS USED ONLY IN 230V APPLICATION.
- 10. JPI AND JF, 1A/1V IN 120V APPLICATION.
- 11. ALL DIODES ARE 1N414B.
- 12. ALL CAPACITOR VALUES ARE IN OHMS ± 5%, 10%, 100V, 2.10V.
- 13. RESISTOR VALUES ARE IN OHMS ± 5%, 10%, 100W.

REFERENCE DESIGNATORS	HIGHEST USED	NOT USED
C1, D1, J1, J2, J3, J4, R1, R2, R3, R4, R5, R6, R7, R8, R9, R10, R11, R12, R13, R14, R15, R16, R17, R18, R19, R20, R21, R22, R23, R24, R25, R26, R27, R28, R29, R30, R31, R32, R33, R34, R35, R36, R37, R38, R39, R40, R41, R42, R43, R44, R45, R46, R47, R48, R49, R50, R51, R52, R53, R54, R55, R56, R57, R58, R59, R60, R61, R62, R63, R64, R65, R66, R67, R68, R69, R70, R71, R72, R73, R74, R75, R76, R77, R78, R79, R80, R81, R82, R83, R84, R85, R86, R87, R88, R89, R90, R91, R92, R93, R94, R95, R96, R97, R98, R99, R100	J1, J2	

NOTES: UNLESS OTHERWISE SPECIFIED:
 DIMENSIONS ARE IN INCHES
 DIMENSIONS IN PARENTHESES ARE IN MILLIMETERS
 DIMENSIONS IN BRACKETS ARE TYPICAL
 DIMENSIONS IN SQUARE BRACKETS ARE MINIMUM
 DIMENSIONS IN TRIANGLE BRACKETS ARE MAXIMUM
 DIMENSIONS IN CIRCLE BRACKETS ARE NOMINAL
 DIMENSIONS IN DIAMETER BRACKETS ARE NOMINAL
 DIMENSIONS IN SQUARE BRACKETS ARE MINIMUM
 DIMENSIONS IN TRIANGLE BRACKETS ARE MAXIMUM
 DIMENSIONS IN CIRCLE BRACKETS ARE NOMINAL

605-00416-00 - 120V
 605-76416-00 - 230V
 605-81416-00 - INACTIVE
 (CANCELLED 7PM.12)

CARVER
 SCHEMATIC DIAGRAM
 POWER SUPPLY, PM 300

FORM NO.	605-XX-416-00	REV.	H
DATE	APPROVED	DATE	APPROVED
1		2/17/60	
2		2/17/60	
3		2/17/60	
4		2/17/60	
5		2/17/60	
6		2/17/60	
7		2/17/60	
8		2/17/60	
9		2/17/60	
10		2/17/60	
11		2/17/60	
12		2/17/60	
13		2/17/60	
14		2/17/60	
15		2/17/60	
16		2/17/60	
17		2/17/60	
18		2/17/60	
19		2/17/60	
20		2/17/60	

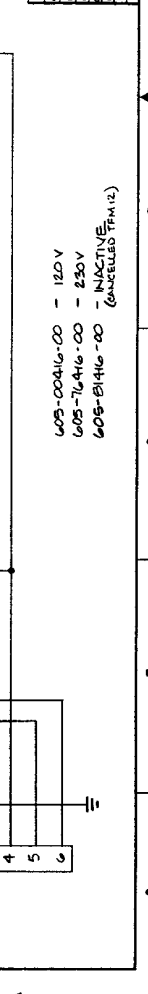

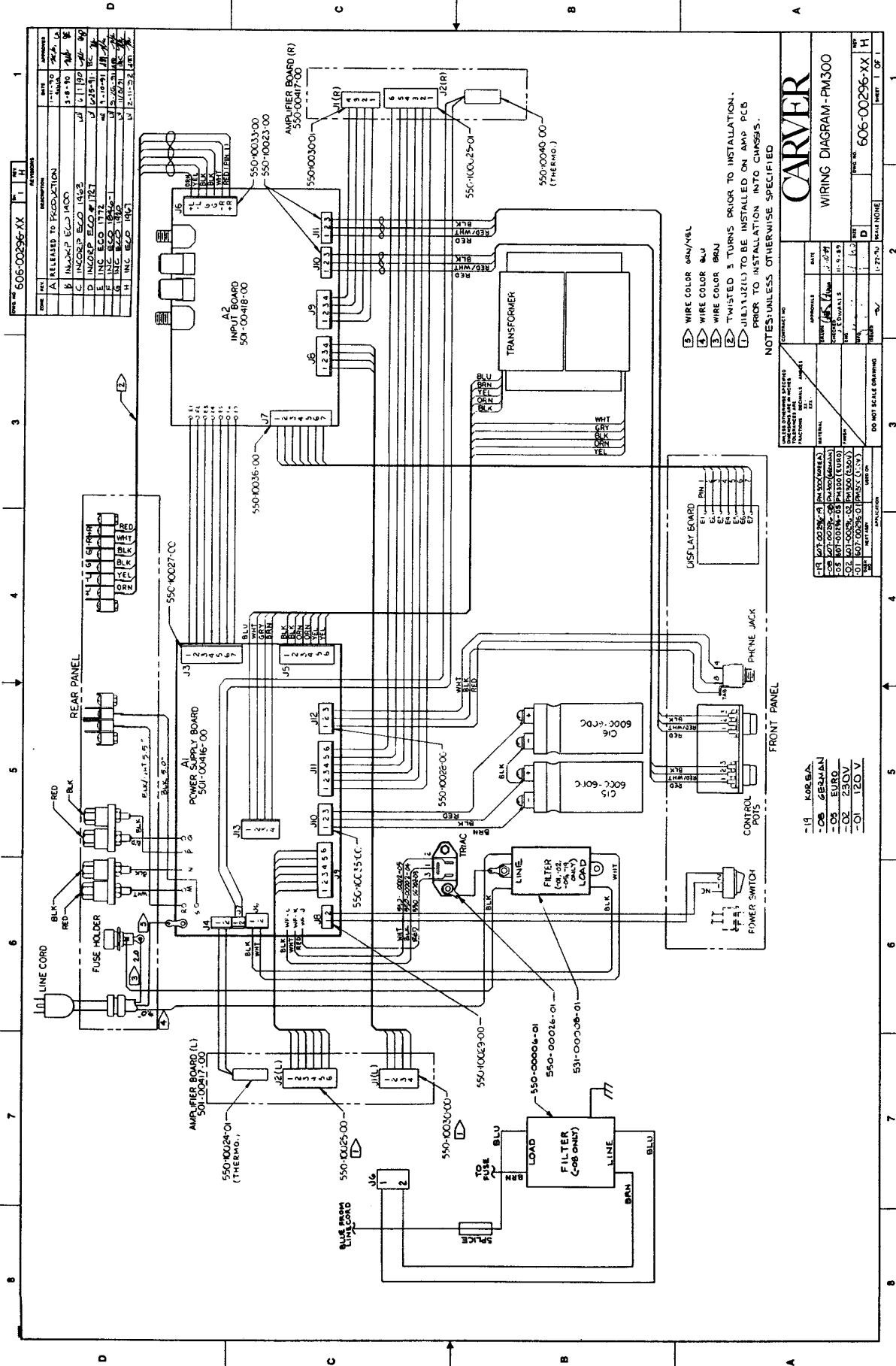

REV	DATE	DESCRIPTION	BY	CHKD
1	11-11-52	REVISED TO PRODUCTION	W	W
2	11-11-52	INCORP. E.C.D. 1400	W	W
3	11-11-52	INCORP. E.C.D. 1423	W	W
4	11-11-52	INCORP. E.C.D. 1427	W	W
5	11-11-52	INCORP. E.C.D. 1446	W	W
6	11-11-52	INCORP. E.C.D. 1446	W	W
7	11-11-52	INCORP. E.C.D. 1446	W	W
8	11-11-52	INCORP. E.C.D. 1446	W	W
9	11-11-52	INCORP. E.C.D. 1446	W	W
10	11-11-52	INCORP. E.C.D. 1446	W	W
11	11-11-52	INCORP. E.C.D. 1446	W	W
12	11-11-52	INCORP. E.C.D. 1446	W	W
13	11-11-52	INCORP. E.C.D. 1446	W	W
14	11-11-52	INCORP. E.C.D. 1446	W	W
15	11-11-52	INCORP. E.C.D. 1446	W	W
16	11-11-52	INCORP. E.C.D. 1446	W	W
17	11-11-52	INCORP. E.C.D. 1446	W	W
18	11-11-52	INCORP. E.C.D. 1446	W	W
19	11-11-52	INCORP. E.C.D. 1446	W	W
20	11-11-52	INCORP. E.C.D. 1446	W	W
21	11-11-52	INCORP. E.C.D. 1446	W	W
22	11-11-52	INCORP. E.C.D. 1446	W	W
23	11-11-52	INCORP. E.C.D. 1446	W	W
24	11-11-52	INCORP. E.C.D. 1446	W	W
25	11-11-52	INCORP. E.C.D. 1446	W	W
26	11-11-52	INCORP. E.C.D. 1446	W	W
27	11-11-52	INCORP. E.C.D. 1446	W	W
28	11-11-52	INCORP. E.C.D. 1446	W	W
29	11-11-52	INCORP. E.C.D. 1446	W	W
30	11-11-52	INCORP. E.C.D. 1446	W	W

- ① WIRE COLOR GRN/YEL
- ② WIRE COLOR BLU
- ③ WIRE COLOR BRN
- ④ TWISTED 3 TURNS PRIOR TO INSTALLATION.
- ⑤ J1(J1/J2) TO BE INSTALLED ON AMP PCB PRIOR TO INSTALLATION INTO CHASSIS.

NOTES: UNLESS OTHERWISE SPECIFIED

CARVER
 WIRING DIAGRAM-PM300

CONTRACT NO. _____
 PART NO. _____
 REV. _____
 DATE _____
 DRAWN BY _____
 CHECKED BY _____
 APPROVED BY _____

DO NOT SCALE DRAWING

1 OF 1

6. In Case of Difficulty

If the PM-300 should fail to operate, here is a list of things to check before contacting an Authorized Carver Service Center (or the factory).

No lights, no sound

No lights, no sound is usually a power supply problem (either the power line itself, or the amplifier's power supply).

- Is the amplifier plugged in?
- Is the outlet live?
- Is the fuse okay?
- Is the power switch set to ON?
- Has the amplifier overheated?

Low Output or No Output

Low or no output problems are usually signal-source, bad cable, or partial-output short circuit related.

- Are the input LEVEL controls set to their normal settings?
- Move the input connections to another amplifier that you know is working to verify that it is not a source problem.
- Check the speaker connections. Be sure that there are no small strands of wire touching similar strands coming from the other wire in the cable. If you use banana plugs, be sure that the setscrews in the plug are securely tightened.
- Are the speakers okay?
- If you are using bridged-mono mode, ensure that the bridged-mono switch is depressed.
- Use a voltmeter to determine if the power line voltage is dropping excessively when the amplifier is driven hard.

Distortion

Distortion is usually caused by excessive loss in the input controls (the mixer/equalizer/crossover can't produce enough output), overdriving resulting in output clipping, or current limiting caused by excessively low load impedances.

- Check the setting of the input level controls. If set too low, the preceding piece of equipment may not have sufficient output to overcome the loss. This is especially possible if you hear distortion, but the yellow PROTECTION LED(s) are not illuminated.
- If the yellow PROTECTION LED(s) are illuminated, check the speaker connections; verify that all setscrews are tight and that there are no stray strands of wire to cause short circuits.
- Verify that the total load impedance presented to the amplifier is within the limits described in this manual for the mode of operation selected.

Protection LEDs Illuminated

The protection LEDs respond to sustained clipping, current limiting, DC or sustained very-low-frequency output.

- Check speaker cables for shorts.
- Are the speakers okay?
- Are you driving the amplifier into sustained clipping?

7. Warranty Information

Note: We suggest you read the LIMITED WARRANTY completely to fully understand your warranty/service coverage. Please promptly complete and return the WARRANTY REGISTRATION CARD. Also be sure to save the sales receipt in a safe place. It will be necessary for warranty service.

If your CARVER product should require service, we suggest you contact the Dealer from whom you purchased your unit. Should the Dealer be unable to take care of your needs, you may contact CARVER Technical Service Department by phoning (206) 775-6245, or by writing to us at the factory address shown at the right. We will then direct you to the nearest in our national network of Authorized Warranty Service Centers, or give you detailed instructions on how to return the product to us for prompt action.

If you should have questions or comments, please write to the factory address given below. Please include the model and serial number of your Carver product, your complete address and a daytime phone number.

Factory Address

Carver Corporation Service Department
P.O. Box 1237
Lynnwood Washington 98046-1237
(206) 775-6245

Carver Corporation reserves the right to improve its products at any time. Therefore, specifications are subject to change without notice.

© 1992 Carver Corporation. All rights reserved.

Pub #900415-B
Part #990-20076-00 Rev. B

Written, designed and printed in USA

Magnetic Field technology protected under U.S.
Patent 4,218,660

CARVER

P R O F E S S I O N A L