

# owner's manual

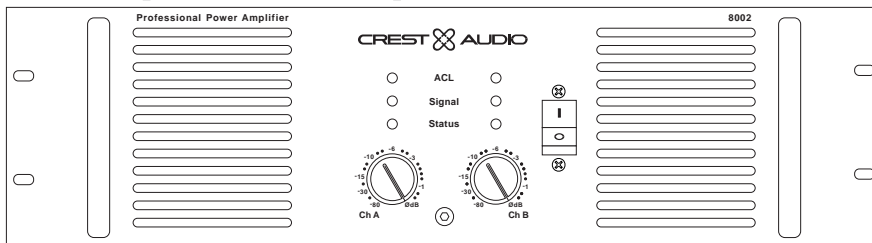

## 8002 power amplifier



# important precautions

---

**1 Save the carton and packing materials!**

Should you ever need to ship the unit, use only the original factory packing.

For replacement packaging, call Crest Audio's Customer Service Department directly.

**2 Read all documentation before operating your equipment.** Retain all documentation for future reference.

**3 Follow all instructions printed on unit chassis for proper operation.**

---

**4 Never hold a power switch in the on-position, if it won't stay there by itself!**

**5 Do not use the unit if the electrical power cord is frayed or broken.**

The power supply cords should be routed so that they are not likely to be walked on or pinched by items placed upon or against them.

**6 Always operate the unit with the AC ground wire connected to the electrical system ground.** Precautions should be taken so that the means of grounding of a piece of equipment is not defeated.

**7 Damage caused by connection to improper AC voltage is not covered by any warranty.** Mains voltage must be correct and the same as that printed on the rear of the unit.

**8 Do not ground any hot (red) terminal. Never connect a hot (red) output to ground or to another hot (red) output!**

---

**9 Power down and disconnect units from mains voltage before making connections.**

**10 Do not drive the inputs with a signal level greater than that required to enable equipment to reach full output.**

**11 Do not run the output of any amplifier channel back into another channel's input.**

**Do not parallel- or series-connect an amplifier output with any other amplifier output.**

Crest Audio is not responsible for damage to loudspeakers for any reason.

**12 Do not connect the inputs or outputs of amplifiers to any other voltage source:** such as a battery, mains source, or power supply, regardless of whether the amplifier is turned on or off.

**13 Connecting amplifier outputs to oscilloscopes or other test equipment while the amplifier is in bridged mono mode may damage both the amplifier and test equipment!**

---

**14 Do not spill water or other liquids into or on the unit, or operate the unit while standing in liquid.**

**15 Do not block fan intake or exhaust ports.**

**Do not operate equipment on a surface or in an environment which may impede the normal flow of air around the unit:** such as a bed, rug, weathersheet, carpet, or completely enclosed rack.

**16 If the unit is used in an extremely dusty or smoky environment:** the unit should be periodically "blown free" of foreign matter.

**17 Do not use the unit near stoves, heat registers, radiators, or other heat producing devices.**

**18 The power cord of equipment should be unplugged from the outlet when left unused for a long period of time.**

## Service Information

**Do not remove the cover!**

Removing the cover will expose you to potentially dangerous voltages. There are no user serviceable parts inside.

**Equipment should be serviced by qualified service personnel when:**

- A. The power supply cord or the plug has been damaged.
- B. The equipment has been exposed to rain.
- C. The equipment does not appear to operate normally, or exhibits a marked change in performance.
- D. The equipment has been dropped, or the enclosure damaged.

**To obtain service:**

contact your nearest Crest Audio Service Center, Distributor, Dealer, or Crest Audio at 201.909.8700 USA or visit [www.crestaudio.com](http://www.crestaudio.com) for additional information.

email [techserve@crestaudio.com](mailto:techserve@crestaudio.com)



This symbol is used to alert the operator to follow important procedures and precautions detailed in documentation.



This symbol is used to warn operators that uninsulated "dangerous voltages" are present within the equipment enclosure that may pose a risk of electric shock.

# table of contents

## **1** how to use this manual p.2

### **introduction** p.3

## **2** installation p.5

unpacking  
mounting  
cooling and ventilation  
powering  
maintenance

## **3** features overview p.11

front panel  
rear panel

## **4** operation modes p.17

stereo  
parallel  
bridged

## **5** connections p.21

input  
output

## **6** safety p.27

tourclass protection  
precautions  
user responsibility

## **7** service and support p.33

support  
contact us  
registration

## **a** specifications p.36

## **b** block diagram p.37

## **c** wire gauge charts p.38

contents

appendixes

# 1 how to use this manual

## conventions

### terms

official Crest Audio features and each indicator or control on the amplifier will appear as: *terms*

### actions

specific actions or selections the user can execute will appear as: *actions*

### tasks

are broken down into steps 

### warnings

Procedures **not** to attempt.  
Issues or hazards to keep in mind when operating the equipment.



### indicators

What to look for on the equipment display.  
Alerts, indicators, or prompts that may appear.



### tips

Preferred methods.  
Helpful hints.  
Feature insights.



### see

see—refers to other sections of the manual containing supplementary information on the current topic or a related issue

### note

note—supplimentary feature information

## welcome

Congratulations on your purchase of a new Pro II Series professional power amplifier, and thank you for your confidence in Crest Audio products. You are among the growing number of audio professionals who have made Crest Audio one of the world's leading suppliers of professional and commercial/industrial audio systems.

For your safety, please read the Important Precautions section before installing and operating the amplifier. The Crest Audio Pro II Series is based on the same advanced circuit topologies that have made Crest's original Professional Series amplifiers the choice of touring professionals worldwide. Pro II Series amplifiers are designed for high operating efficiency and accurate sonic performance across the full audio bandwidth, even under stressful conditions.

The Pro II Series heralds a major advance in amplifier design from Crest Audio, providing the extreme reliability and hallmark sonic accuracy for which Crest products are famous, in a rugged package but at only half the weight of previous models of similar power. These dramatic weight savings are made possible by PowerLok, a radical new power-supply technology that provides significant performance and flexibility advances over conventional designs. PowerLok is Crest Audio's unique implementation of Power Factor Correction, which allows current to be drawn throughout the entire cycle of the AC line-frequency, providing maximum output power, while drawing significantly smaller peak currents from the AC line.

Compared with an amplifier using a conventional power-supply, PowerLok requires less peak power to produce identical output power, and because PowerLok's current peaks are smaller, a Pro II amplifier can be serviced by a lower-rated breaker than a conventional amplifier of similar wattage. See separate literature for full details on the benefits of PowerLok technology.

In order to maintain strict quality assurance standards, all Crest Audio power amplifiers are built in our state-of-the-art USA manufacturing facility. Internal components are the finest available and key sub-assemblies are pre-tested before final assembly. Each amplifier is "burned in" and thoroughly tested (using precision audio test equipment) before shipping. In addition, all Pro II Series amplifiers incorporate Crest's exclusive TourClass protection features to safeguard both internal circuitry and connected loudspeakers.

This proven combination of advanced design, quality construction, and comprehensive circuit protection is your guarantee of fail-safe reliability. You can depend on consistent, stable performance even when your Pro II Series amplifier is subjected to punishing extremes in the most demanding fixed or mobile sound reinforcement applications.



- ▶ what to do with the shipping carton
- ▶ proper rack-mounting technique
- ▶ keeping the amplifier cooled
- ▶ grounding the amplifier
- ▶ required AC line voltages
- ▶ routine maintenance practices

**unpacking**

**mounting**

**cooling and  
ventilation**

**powering**

**maintenance**

### unpacking

Please inspect the amplifier carefully immediately after unpacking. If you find any damage, notify your supplier/dealer immediately. Only the shipper may file a damage claim with the carrier for damage incurred during shipping. Be sure to save the carton and all packing materials for the carrier's inspection.

**If the packing materials are in good condition, please save them.** If you ever need to ship the unit back to Crest Audio or an authorized service center, you should use only the original factory packing.

For replacement packaging, call Crest Audio's Customer Service Department directly. see—**service and support**





## mounting

All Pro II Series amplifiers mount in standard 19-inch racks. Four front-panel mounting holes are provided on each amplifier. Rear mounting ears give additional support, and use of rear supports is highly recommended in all mobile and touring sound systems. Handles are fitted standard.

### 8002 shown

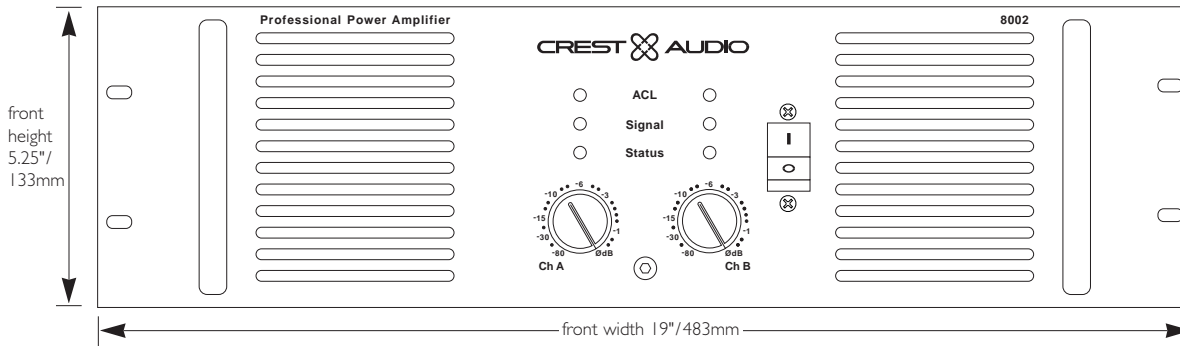

### 8002 shown

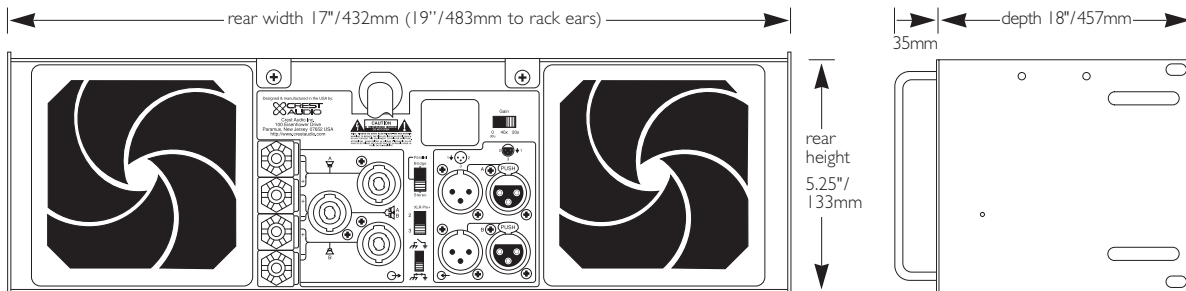

### cooling and ventilation

Pro II Series amplifiers use a twin-tunnel forced-air cooling system to maintain a low, even operating temperature.

Drawn in by dual 105 CFM (cubic feet-per-minute) DC fans on the rear panel, air flows through the cooling fins of the channel heat-sinks, dissipating power transistor heat—then exhausts through the front panel slots.

Heat sink temperature-sensing circuits control the “intelligent” variable-speed fans. Fan speed increases only as required by heat-sink temperatures—keeping fan noise to a minimum.

Under extreme thermal load, the fans will force a very large volume of air through the heat sinks. If either heat-sink surpasses the maximum allowed temperature, the sensing circuit will open the output relay, disconnecting the load from that channel.

If the power supply overheats, another sensing circuit opens both channel output relays, until it has cooled to a safe temperature.

To ensure optimum cooling of the amplifier, periodically clean its fan filters. These are removable without tools.



Make certain that there is enough space around the front of the amplifier to allow the heated air to escape. If the amplifier is rack-mounted, do **not** use doors or covers on the front of the rack; the exhaust air must not be impeded.

In racks with closed backs: for every four amplifiers, allow at least **one** standard-rack-space opening in the front of the rack.

## powering

Unless otherwise specified when ordered, Pro II amplifiers shipped to customers are configured as follows:

<b>North America</b>	90–255 VAC @ 50–60Hz
<b>Europe</b>	180–255 VAC @ 50–60Hz
<b>Asia</b>	180–255 VAC @ 50–60Hz
<b>Australasia</b>	180–255 VAC @ 50–60Hz
<b>South America</b>	90–255 VAC @ 50–60Hz
<b>Japan</b>	90–255 VAC @ 50–60Hz

Always turn off and disconnect the amplifier from mains voltage before making audio connections.



As an extra precaution, have the attenuators turned down during power-up.

## maintenance

A Pro II Series amplifier requires no routine maintenance other than the occasional cleaning or replacement of the fan intake filters on the rear of the amplifier. (This operation does not require any tools.) Filters must be kept clear and clean to ensure proper ventilation through the unit.

If the amplifier is used in an extremely dusty or smoky environment, the filter should be cleaned or changed frequently and the unit should be periodically “blown free” (using compressed air) of any foreign matter that may have penetrated the filter.

Users will not need to make any internal adjustments to the amplifier during its lifetime. There are no user-serviceable parts or adjustments that require opening the power amplifier.

Cover removal exposes the risk of shock, so refer all servicing to qualified service technicians authorized by Crest Audio.





- location of connectors and controls
- legend of panel symbols

**front panel**

**rear panel**

# 3 features overview

8002 shown

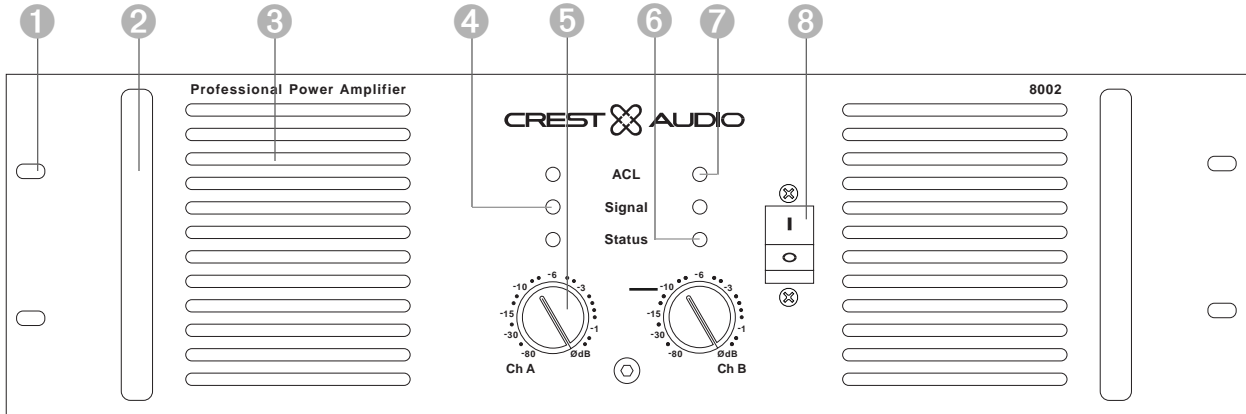

## front panel

### 1 Rack Mounting Ears

Two front-panel mounting holes are provided on each mounting ear.

### 2 Rack Handles

### 3 Fan Outlet Grills

Pro II Series amplifiers are cooled by two, rear-mounted fans. Cool air flows over the heat sinks and exhausts through the front grills. Make sure these outlets remain clear to allow unrestricted airflow.

### 4 Signal LED

A variable-intensity LED that illuminates to indicate that a signal (above a minimum threshold) is present at the amplifier input, and that the signal is being amplified.

### 5 Input Attenuators

Two input attenuators adjust level for their respective amplifier channels. In Bridged Mono mode, the channel A attenuator controls signal level.

### 6 Status LED

A bi-color LED. When green, it indicates that AC power is connected and the amplifier is turned on. When red, the channel is in Protect mode (speakers disconnected by output relay).

### 7 ACL LED

Illuminates at the clipping threshold. Continuous illumination also indicates that ACL ACTIVE CLIP LIMITING protection circuitry is engaged.

### 8 AC Power Switch/Circuit Breaker

Pro II Series amplifiers have a front-panel combination AC switch/circuit breaker. (No fuses are used.) If the switch shuts off during normal use, push it back to the on-position once. If it will not stay on, the amplifier needs servicing.

Never try to hold the circuit breaker/power switch in the on-position, if it won't stay there itself!



note—all LEDs are one per channel

## 8002 shown

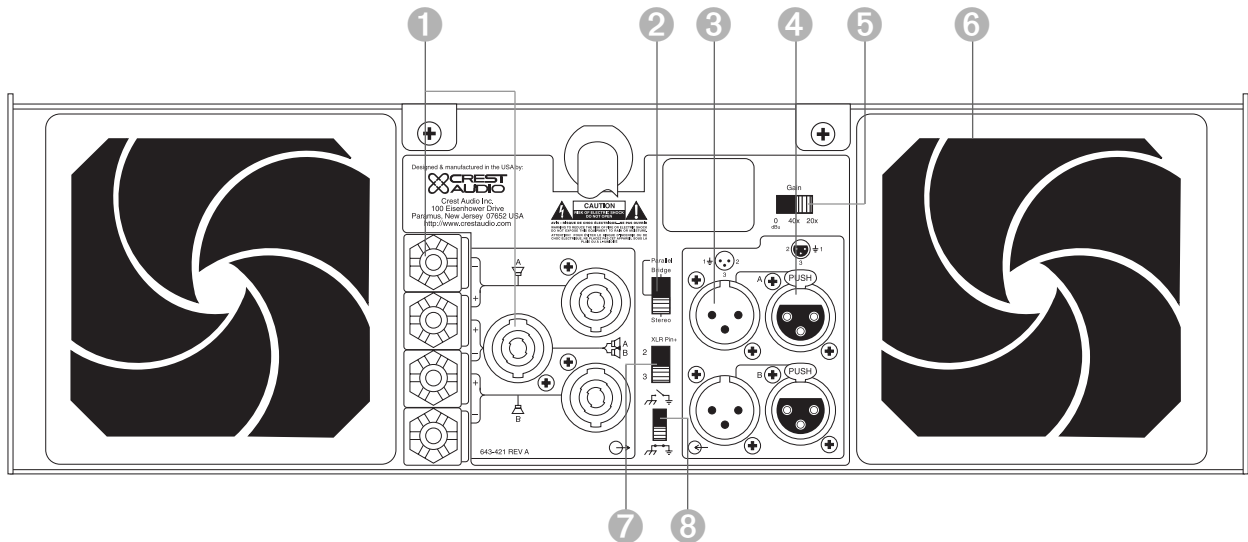

### rear panel

#### 1 Output Connectors

Pro II Series power amplifiers are supplied with both high-current five-way binding posts and Speakons installed. Binding posts: one pair per channel. Speakons: one connector per channel, plus a third connector configured for bridged-mono operation.

Connection to the binding posts can be made with bare wire or spade lug terminations. Make connections to both the channel A and channel B terminals for Stereo or Parallel mode, or a single connection across the red (hot) terminals only of channels A and B for Bridged Mono mode.

Using cables terminated with Speakon connectors, attach to both the channel A and channel B connectors for Stereo or Parallel mode, or to the Bridged mode connector/s for Bridged Mono mode.

see—**operation modes**

















#### 2 Mode Selection Switch

This recessed, three-position switch configures the amplifier for Stereo, Parallel or Bridged Mono mode operation. Amplifiers are factory-configured for Stereo mode.

see—**operation modes**

Do **not** adjust the mode selection switch while the amplifier is turned-on. 

#### rear panel legend

-  input connection
-  XLR connector polarity
-  TRS connector polarity
-  bridged mono mode
-  parallel mode
-  stereo mode
-  chassis ground lifted-position
-  chassis ground grounded-position
-  gain select
-  XLR pin 2/3 hot (+)
-  output connection
-  speakon output channel A stereo/parallel
-  channel B stereo/parallel
-  bridged mono
-  five-way binding post channel A stereo/parallel
-  bridged mono
-  channel B stereo/parallel



## rear panel

### 3 Female Balanced XLR Input Connectors

### 4 Male Balanced XLR Input Connectors

These connectors accept input signals on balanced male and female XLR input plugs. Connectors for each channel are in parallel; any unused XLR connectors may be used for daisy-chaining input connections to other amplifiers.

In Parallel and Bridge Mono mode a signal applied to channel A's input connectors will appear also at channel B's.

### 5 Input Sensitivity/Gain Switch

The Pro II Series amplifiers come standard set to  $\times 40$  gain.

The Input Sensitivity/Gain switch allows the user to select either .775 (0dB) sensitivity,  $\times 40$ , or  $\times 20$  gain.

### 6 Fan Inlet Ports and Filters

Cooling air enters the amplifier through the fan inlet ports located on the rear of the amplifier chassis. Be sure not to block these ports when installing the amplifier or other associated equipment. Air must flow unimpeded. Fan filters (removable without tools) are provided to minimize entry of dust and dirt.

### 7 Input XLR Polarity Switch

Pro II Series amplifiers are supplied standard with the XLR configured as Pin 2 hot (+). Use the XLR polarity switch to change this setting to Pin 3 hot (+) if desired.

### 8 Signal Ground-Lift Switch

The recessed signal ground-lift switch electrically connects signal ground to the chassis/AC ground. This switch is factory-set to the ground position (bottom). The top position *lifts* the amplifier's signal ground. In a properly designed system (for safety purposes and to minimize noise), amplifiers should be connected to ground through the AC line cord.

Whenever possible, the signal source equipment should share the same AC ground as the amplifier. In some cases this may not be possible, and a ground loop results. If this happens, the first step is to move the ground-lift switch to the *lifted* position (top). In this position, the signal ground is lifted and completely isolated from the chassis/AC ground. Do not change the switch to the lifted position if the amplifier and the signal source equipment are on the same AC ground.

Should the ground loop problem persist after the ground-lift switch has been set to the lifted position, then the shield on balanced input lines should be grounded at one end only (usually the signal source).

Never connect a **hot** (red) output to ground or to another **hot** (red) output!





- choosing the appropriate mode
- switching between operation modes
- keeping the amplifier cooled
- special considerations when using bridged mode

**stereo**

**parallel**

**bridged**

## mode selection

The three-position, recessed Mode Select switch (located on the rear panel) configures the amplifier for Stereo, Parallel or Bridged mode. Amplifiers are factory-configured for Stereo mode.

## stereo

In Stereo mode, both channels operate independently, with their input attenuators controlling their respective levels. Signal at Channel A's input produces output at Channel A's output, while signal at Channel B's input produces output at Channel B's output. Recommended minimum nominal load impedance for stereo operation is 2 ohms per channel. Either the male or female XLR inputs may be used.

## parallel

When set to Parallel mode, a signal applied to Channel A's input will be amplified and appear at outputs for both Channels A and B. Either the male or female XLR input on Channel A may be used. Individual channel attenuators control signal level.

## bridged

Bridged mode straps both amplifier channels together to make a very powerful, single-channel monaural amplifier. One channel "pushes" and the other "pulls" equally, doubling the power over that of either channel alone. Signal is applied to the Channel A input only. Channel A's attenuator is used to control signal level. Either male or female XLR input may be used.

The channel B input connectors (male or female XLR) may be used to daisy-chain the channel A signal when in parallel or bridged mono mode. Use extreme caution when operating the amplifier in Bridged mode. Never ground either side of the speaker cable when the amplifier is in Bridged mode; both sides are "hot."

If an output patch panel is used, all connections must be isolated from each other and from the panel. The recommended minimum nominal load impedance in the Bridged mode is 4 ohms, which is the equivalent to driving both channels separately at 2 ohms.

see—**connections** for examples of mode-specific wirings

Driving bridged loads of less than the recommended minimums will activate the IGM circuitry, resulting in a loss of power, and may also lead to a thermal protect condition.



Connecting amplifier outputs to oscilloscopes or other test equipment while the amplifier is in **bridged** mode may damage both the amplifier and test equipment!



# **operation modes** 4

---



► proper wiring schemes for connectors: XLR  
speakon  
binding post

**input**

► correct signal paths: stereo, parallel, and bridged

**output**

# 5 connections

## inputs

Use either male or female XLR connectors on the rear to supply audio signals to the inputs of your Crest Audio Pro II Series amplifier.

Pro II Series amplifiers are configured standard with pin 2 hot on XLR inputs. The input XLR polarity switch can configure pin 3 hot if required.

Some other Crest Audio amplifiers are configured with pin 3 **hot**. 

### male XLR

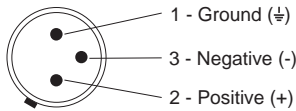

### female XLR

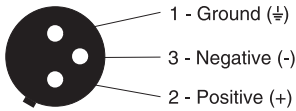

The unused connector can be used to jumper the audio input to another amplifier input. 

input sensitivity options		
	gain	sens
position 1	Ø	.775v
position 2	x40	2.0v
position 3	x20	4.0v

## outputs

Speakers are connected using the high-current five-way binding posts or speakon connectors, or both, depending on preference and model.

### stereo/parallel

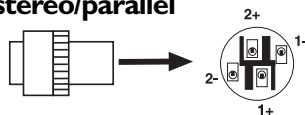

Speaker + to PIN 1 +  
Speaker - to PIN 1 -

### bridged mono

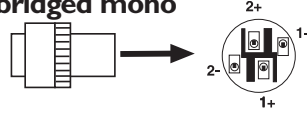

Speaker + to PIN 1 + PIN 1 -  
Speaker - to PIN 2 + PIN 2 -

Very high current is available at the outputs.   
Please connect your output cable to the + and - terminals of each section precisely as shown.

see—**operation modes**



**stereo mode**  
five-way binding post connectors

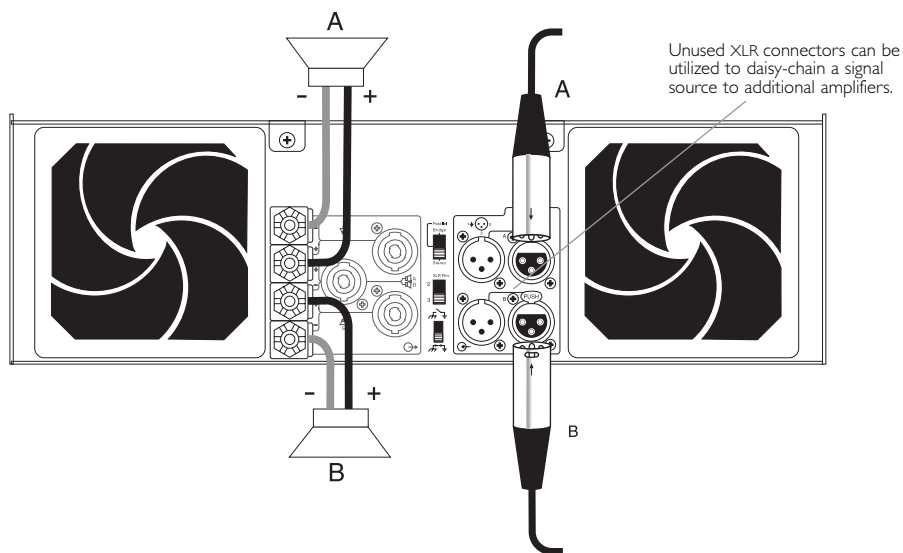

**parallel mode**  
five-way binding post connectors

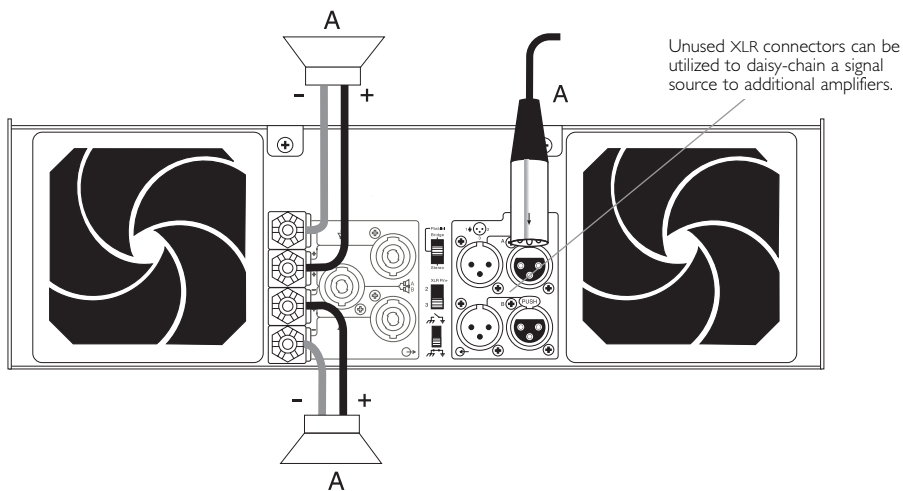

**bridged mono mode**  
five-way binding post connectors

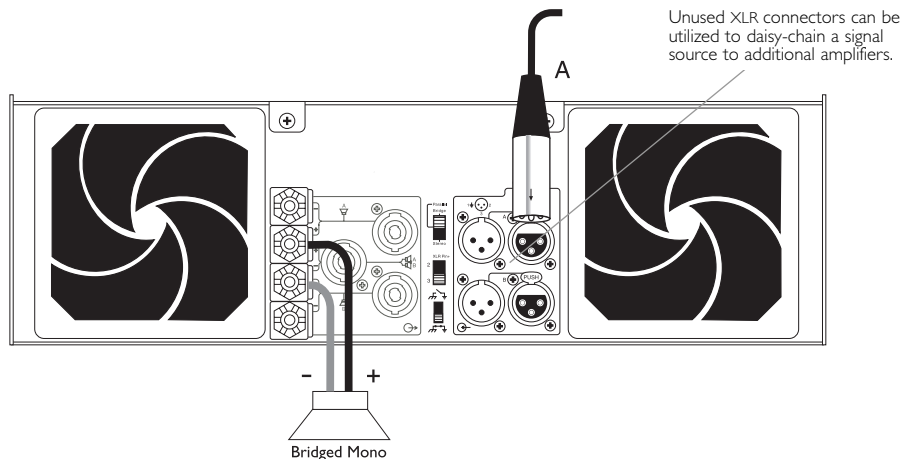

# 5 connections

## stereo mode speakon output connectors

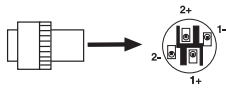

Speaker + to PIN 1 +  
Speaker - to PIN 1 -

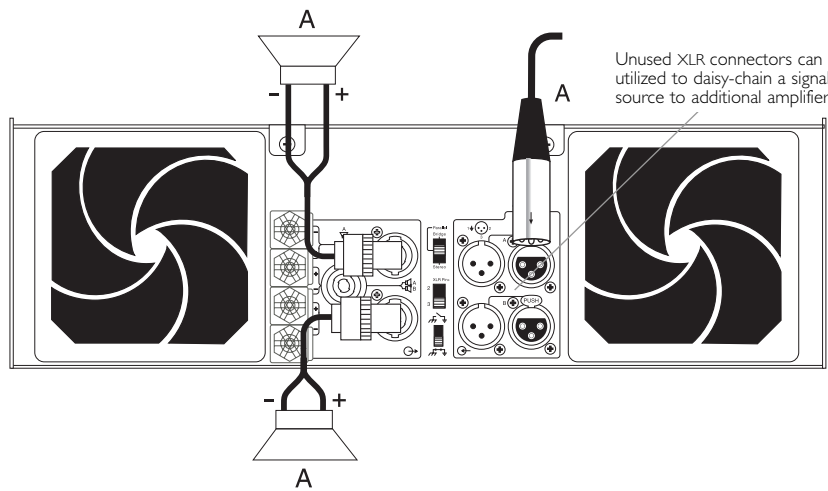

## parallel mode speakon output connectors

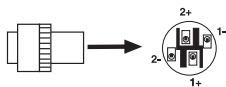

Speaker + to PIN 1 +  
Speaker - to PIN 1 -

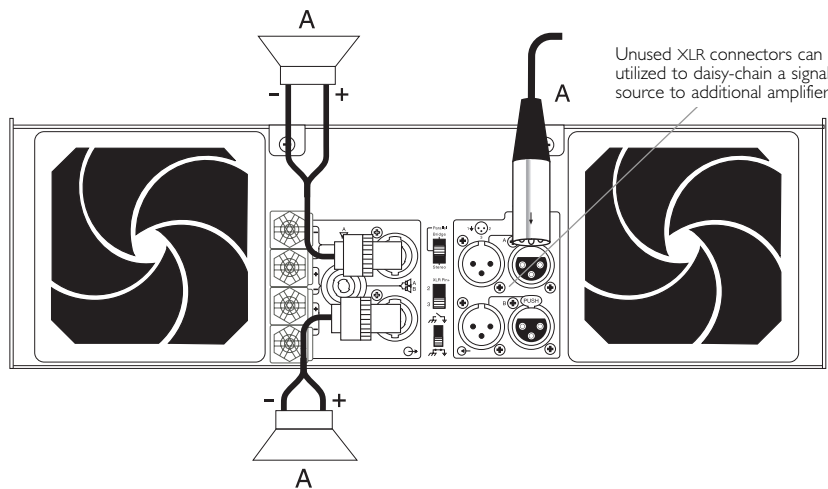

## bridged mono mode speakon output connectors

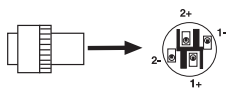

Speaker + to PIN 1 + PIN 1 -  
Speaker - to PIN 2 + PIN 2 -

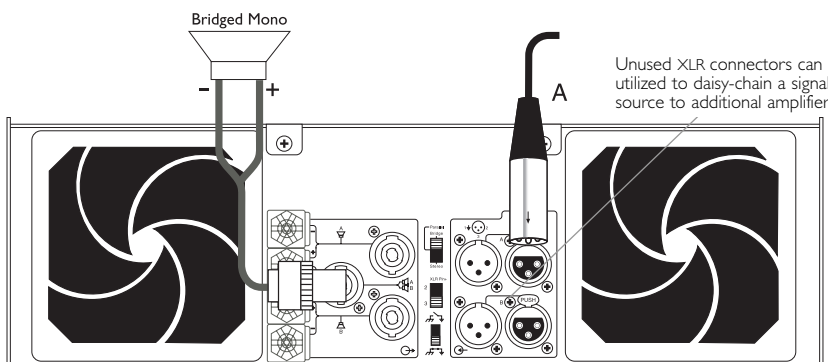





- the owner's role in amplifier safety
- description of TourClass protection features
- protecting your speakers

**user  
responsibility**

**speaker  
protection**

**TourClass**

## **user responsibility**

Your Pro II Series amplifier is very powerful and can be potentially dangerous to loudspeakers and operators alike. It is your responsibility to read **important precautions** (see the inside-front cover) and make sure that the amplifier is installed, wired, and operated properly as instructed in this manual.

Many loudspeakers can be easily damaged or destroyed by overpowering, especially with the high power available from a bridged amplifier. Always be aware of the speaker's continuous and peak power capabilities. Crest Audio is not responsible for damage to loudspeakers for any reason.

see—**speaker protection**

## speaker protection

All loudspeakers have electrical, thermal, and physical limits which must be observed to prevent damage or failure. Cone or compression drivers can be damaged (sometimes to the point of failure) from excessive power, low frequencies applied to high frequency drivers, severely clipped waveforms, and DC voltage. All Pro II Series amplifiers automatically protect speakers from DC voltages and subsonic signals.

see—**TourClass protection**

Mid- and high-frequency transducers—compression drivers in particular—are highly susceptible to damage from overpowering, clipped waveforms, or frequencies below their rated passband. When using an electronic crossover, make absolutely certain that the low and mid bands are connected to the correct amplifiers and drivers—and not accidentally connected to those for a higher or lower frequency band.

The amplifier's clipping point is its maximum peak output power. At maximum peak output power, Crest Audio Pro II Series amplifiers will deliver more power than many speakers can safely handle. Be sure the peak power capability of the amplifier is not excessive for your speaker system. To ensure that the speakers never receive excessive power, and to prevent amplifier clipping, use a properly adjusted external limiter (or a compressor with a ratio of 10:1 or higher) to control power output. Use one compressor/limiter for each frequency band in systems with active electronic crossovers.

The ACL clip limiting circuit will automatically limit the duration of squared-off, continuous waveforms applied to the speakers. The amplifier will, however, allow normal musical transient bursts to pass. Of course, when the amplifier does clip, it is operating at its maximum output power. Note that some speaker systems are packaged with proprietary “processors” that have power limiting circuits and therefore should not require additional limiting. Do not drive any low-frequency speaker enclosure with frequencies lower than its own tuned frequency; the reduced acoustical damping could cause a ported speaker to “bottom out” even at moderate power. Consult the speaker system specifications to determine its frequency limits, and employ a roll-off filter if necessary.

### recommended speaker cabling

The wire gauge charts will assist you in determining the optimum copper wire gauge for your speaker cables. Remember that the speaker cable resistance robs amplifier power in two ways: through power lost directly to resistance (often referred to as  $I^2R$  loss), and through increased total load resistance, which decreases the amount of power available from the amplifier. Appendix C gives cable length figures in feet/AVG wire gauges and in metric values.

see—**wire gauge**

## TourClass® protection

Every model in the Pro II Series incorporates TourClass protection features. Derived from Crest Audio's extensive experience with the world's largest sound rental companies, the TourClass group of circuits sets the industry standard for assured protection of internal amplifier circuits and all connected loads.

### **ACL** ACTIVE CLIP LIMITING

At the amplifier's full power limit, or clipping point, ACL will be activated. This is indicated by illumination of the ACL LED. The channel gain is automatically reduced, protecting the loudspeakers from potential damage from the high power, continuous square waves that would otherwise be produced. ACL may be activated by uncontrolled feedback, oscillations, improper equipment gain settings, or an equipment malfunction upstream from the amplifier. Only steady or excessive clipping (not normal program transients) will trigger ACL. The circuit is virtually transparent in operation and full signal bandwidth is maintained.

### **IGM** INSTANTANEOUS GAIN MODULATION

IGM is an innovative circuit that allows the amplifier to operate safely into loads as low as 2 ohms. When the amplifier sees a load that overstresses the output stage, the IGM circuit adjusts the channel gain to a safe level. Like ACL, the IGM circuit is inaudible in normal use. In addition, if extreme and sustained low impedance is encountered, the amplifier's output relay will open.

### **AutoRamp**

Auto Ramp operates every time the amplifier is turned on or is reactivated after a protect condition is corrected. This exclusive Crest Audio feature gradually increases gain to the attenuator setting avoiding unnecessary stress on the loudspeakers.

### **Thermal**

Abnormally high heat sink temperatures will engage the Protect circuit for the overheating channel only. (An output relay disconnects the loudspeakers until nominal temperature range is restored.) During this time, the Status LED will light red. If the power supply gets too hot, its thermal sensing circuit will disconnect both channel outputs. During this time, the Active LED will extinguish, the Status LED will remain red, and the cooling fan will continue running at high speed. Normal operation resumes once the power supply cools to a safe level.

### **Short Circuit**

If an output is shorted (i.e., defective speakers or crossed speaker wires) the IGM and thermal circuits will automatically protect the amplifier. The IGM circuit senses the short circuit as an extremely stressful load condition and attenuates the signal, protecting the channel's output transistors from over-current stress. If the short circuit remains, the load will be disconnected by the thermal protection circuitry (the output relay opens).



## **DC Voltage**

If an amplifier channel detects DC voltage at its output terminals, the output relay will immediately open to prevent loudspeaker damage. The Status LEDs will turn red.

## **Subsonic Frequencies**

Built-in high pass filtering provides subsonic frequency protection for each channel. In addition, a relay will open if excessive subsonic energy appears at the output.



- when to get support
- ways to contact Crest Audio

**support**

**contact us**

## support

In the unlikely event that your amplifier develops a problem, it must be returned to an authorized distributor, service center or shipped directly to our factory.

To obtain service, contact your nearest Crest Audio Service Center, Distributor, Dealer, or any of the worldwide Crest Audio offices. For those with Internet access, please visit the Crest Audio website.

Because of the complexity of the design and the risk of electrical shock, all repairs should be attempted only by qualified technical personnel.



## contact us

### customer service

phone 201.909.8700 USA  
fax 201.909.8744 USA  
email [customerserve@crestaudio.com](mailto:customerserve@crestaudio.com)

### technical support

phone 201.909.8700 USA  
fax 201.587.0550 USA  
email [techserve@crestaudio.com](mailto:techserve@crestaudio.com)

### website

[www.crestaudio.com](http://www.crestaudio.com)

### mail

Crest Audio Inc.  
100 Eisenhower Drive  
Paramus, NJ 07652 USA

If the unit needs to be shipped back to the factory, it must be sent in its original carton.

If improperly packed, your amplifier may be damaged.



For replacement packaging, call Crest Audio's Customer Service Department directly.



# **service and support 7**

---

## 8002

	1kHz, 0.1% THD+N	20Hz–20kHz, 0.1% THD+N
Stereo power 8Ω	800W	750W
	4Ω 1400W	1350W
	2Ω 2000W	1900W
Bridged mono power 8Ω	2800W	2700W
	4Ω 4000W	3800W
Maximum output voltage	92V rms, 130V peak each channel	

Frequency response 1w @ 8Ω 20Hz–20kHz, +0 / -0.3dB, -3dB@135kHz

Power bandwidth rated power @ 4Ω, 1% THD+N 20Hz–20kHz, +0 / -0.23dB

THD+N	<0.05% rated power @ 4Ω, 1kHz
SMPTÉ IMD	<0.01% rated power @ 8Ω, 60Hz and 7kHz
Damping factor	400:1 10–400Hz @ 8Ω

Input CMRR	>60dB @ 1kHz
Switch-configurable input options	.775V constant sensitivity, x20 or x40 constant gain
Input impedance	>20kΩ balanced, >10kΩ unbalanced
Hum and noise	-110dB, A-weighted below rated power
Crosstalk	> -80dB @ 1kHz below rated power

Class	H	
Power supply	two versions: 90–255 or 180–255 vac @ 50–60Hz factory configured PowerLok power supply with active power factor correction	
Circuit breaker rating 4Ω	36A @ 120V	
Current draw 1/8 power, 4Ω	<7.7A @120V	
	1/3 power, 4Ω	<17.3A @120V
	at power-up	<50A @120V
	at idle	<1.5A @120V
Peak current draw	51A	

Thermal emissions 1/8 Power, 4Ω 2083 BTU/Hr

1/3 Power, 4Ω 3899 BTU/Hr

Cooling back-to-front via two rear-mounted variable-speed DC fans

Input connectors	female and male xlr pin 2+ switch-configurable for pin 3+
Output connectors	speakon connectors and five-way output binding posts
Controls	front panel: two attenuators, power switch incorporating magnetic circuit breaker rear panel: signal ground-lift, mode select, input sensitivity, pin 2/3+
LED indicators	ACL, SIGNAL, STATUS bi-color: active / protect
TourClass® protection	ACL, IGM, AUTORAMP, SHORT CIRCUIT, DC VOLTAGE, TURN-ON/-OFF TRANSIENT, CURRENT IN-RUSH, SUB/ULTRASONIC INPUT

Construction	aluminum chassis double thickness in rack-ear areas
Dimensions	5.25" x 19" x 18" 133 x 483 x 457mm height x width x depth
Weight	gross: 47lbs 21.7kg
	net: 42lbs 19.1kg
Warranty	five years USA, Canada, United Kingdom, and many other countries

see—connections for input sensitivity options

# block diagram **b**

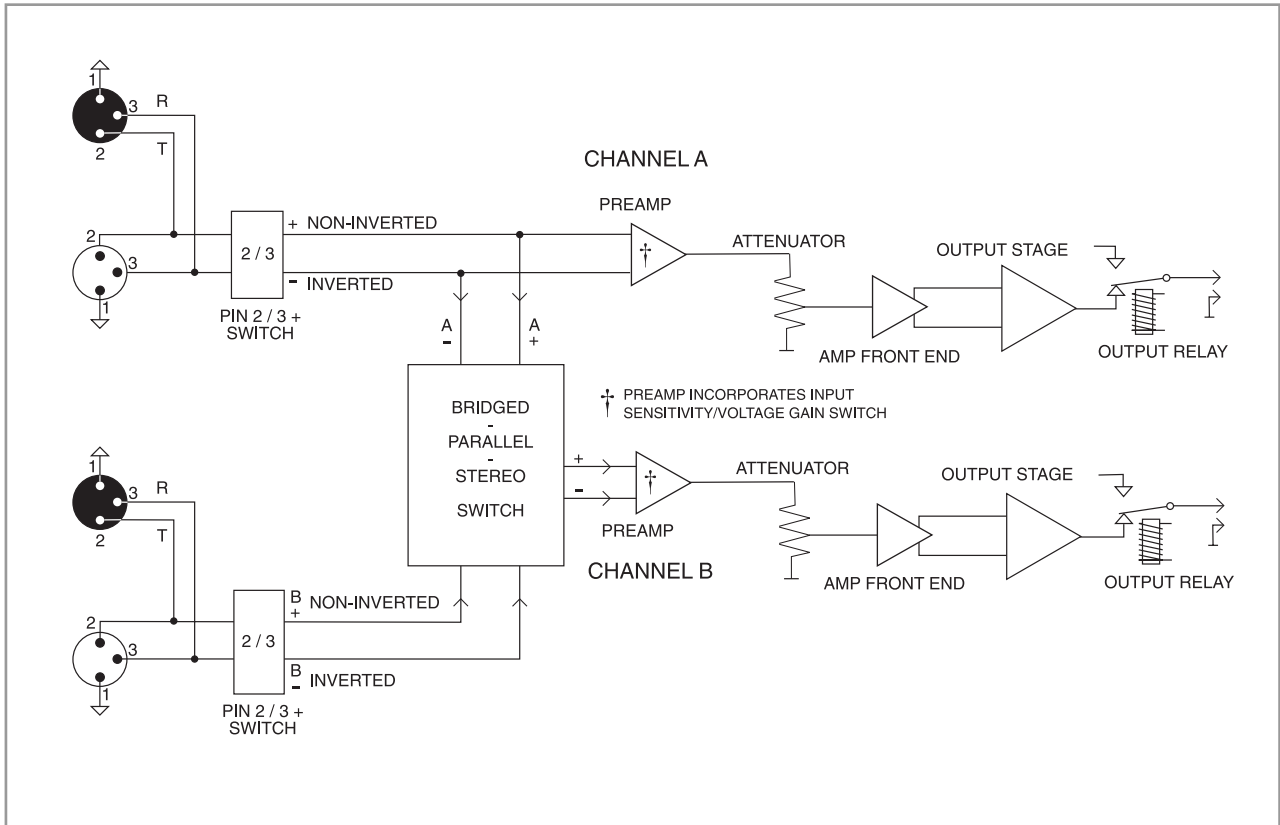

stranded cable length	wire gauge	8 $\Omega$ load	4 $\Omega$ load	power loss 2 $\Omega$ load
<b>2</b> meters	0.3mm <sup>2</sup>	2.9%	5.6%	10.8%
	0.5	1.74	3.4	6.7
	0.75	1.16	2.3	4.5
	1.5	0.58	1.16	2.3
	2.5	0.35	0.70	1.39
	4.0	0.22	0.44	0.87
<b>5</b> meters	0.5mm <sup>2</sup>	4.3%	8.2%	15.5%
	0.75	2.9	5.6	10.8
	1.5	1.45	2.9	5.6
	2.5	0.87	1.74	3.4
	4	0.55	1.09	2.2
	6	0.37	0.73	1.45
<b>10</b> meters	0.5mm <sup>2</sup>	8.24%	5.5%	28%
	0.75	5.6	10.8	19.9
	1.5	2.9	5.6	10.8
	2.5	1.74	2.9	6.7
	4	1.09	1.74	4.3
	6	0.73	1.09	2.9
<b>30</b> meters	0.75mm <sup>2</sup>	15.5%	0.73%	45%
	1.5	8.2	15.5	28
	2.5	5.1	9.8	18.2
	4	3.2	6.3	12.0
	6	2.2	4.3	8.2
	10	1.31	2.6	5.1



stranded cable length	wire gauge	8Ω load	4Ω load	power loss 2Ω load
<b>5</b> feet	18AWG	0.81%	1.61%	3.2%
	16	0.51	1.02	2.0
	14	0.32	0.64	1.28
	12	0.20	0.40	0.80
	10	0.128	0.25	0.51
<b>10</b> feet	18AWG	1.61%	3.2%	6.2%
	16	1.02	2.0	4.0
	14	0.64	1.28	2.5
	12	0.40	0.80	1.60
	10	0.25	0.51	1.01
<b>40</b> feet	18AWG	6.2%	11.9%	22%
	16	4.0	7.7	14.6
	14	2.5	5.0	9.6
	12	1.60	3.2	6.2
	10	1.01	2.0	4.0
	8	0.60	1.20	2.4
<b>80</b> feet	18AWG	11.9%	22%	37%
	16	7.7	14.6	26
	14	5.0	9.6	17.8
	12	3.2	6.2	11.8
	10	2.0	4.0	7.7
	8	1.20	2.4	4.7



v. 1.0 \*A4400076\* 4/29/98

**Crest Audio Inc.**  
100 Eisenhower Dr., Paramus NJ 07652 USA  
TEL: 201.909.8700 FAX: 201.909.8744  
<http://www.crestaudio.com>