

JUL 27 1994



# Electro-Voice<sup>®</sup>

## SYSTEM 200™ MODULAR PRO AUDIO

### OWNER'S MANUAL

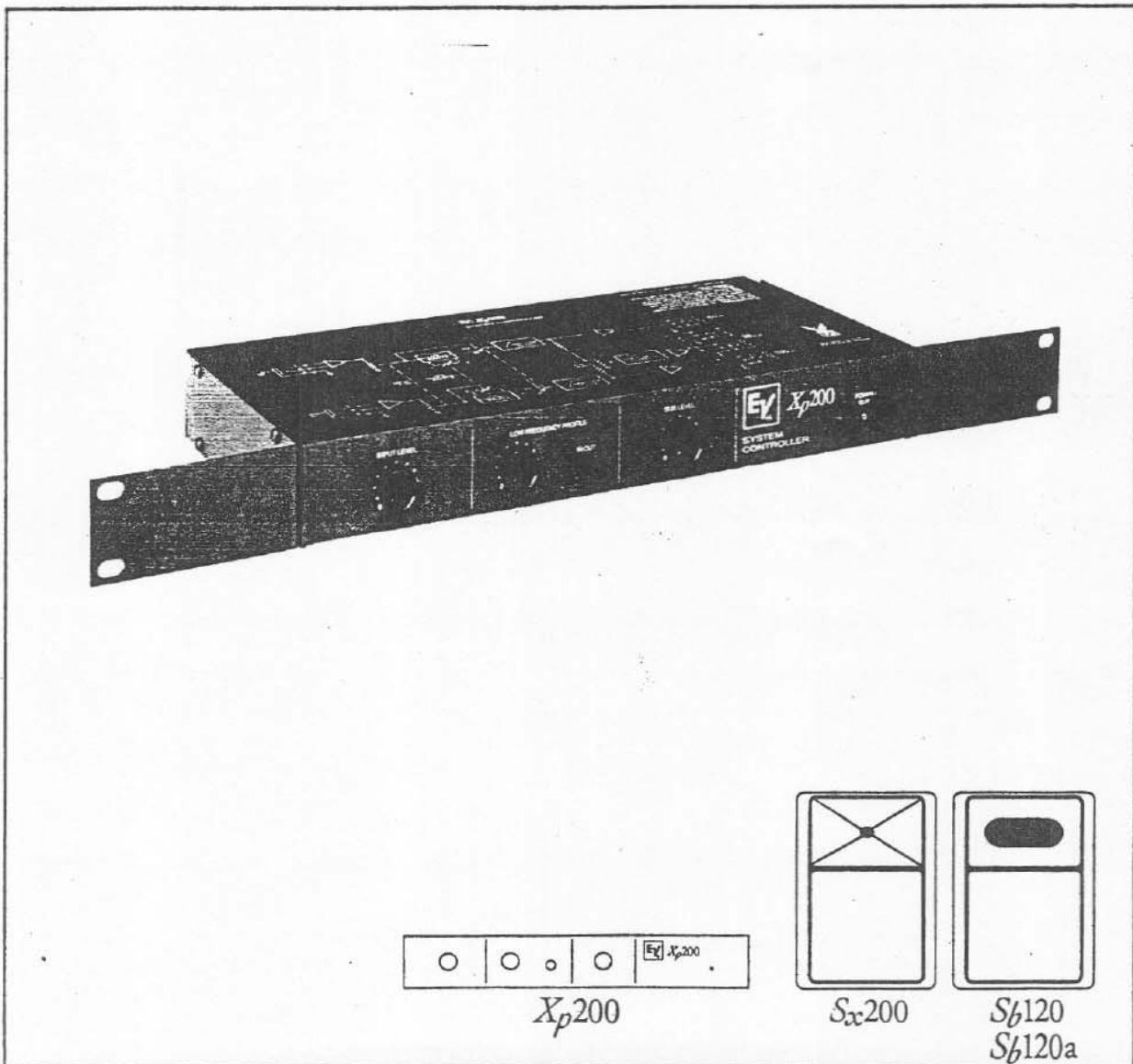

**Xp200 CONTROLLER  
AND ITS USE WITH THE  
Sx200, Sb120a and Sb120 SPEAKER SYSTEMS**

**TABLE OF CONTENTS****DESCRIPTION**

General .....	page 1
Xp200 Feature Summary .....	page 1

**SPECIFICATIONS**

Xp200 Controller .....	page 2
System 200™ Speaker System Specifications (selected) .....	page 3

**FREQUENCY AND BEAMWIDTH RESPONSE CURVES .....** page 4

Xp200 Controller
Sx200 Full-Range Speaker System
Sb120a Powered Bass Module
Sb120 Nonpowered Bass Module

**Xp200 BLOCK DIAGRAM .....** page 5**OPERATION AND INSTALLATION**

Front-Panel Indicators and Controls .....	page 6
Back-Panel Connections .....	page 7
Mounting/Installation .....	page 8
Typical System 200™ Modular Pro Audio Configurations .....	pages 8-12
Connector and Cable Requirements .....	pages 13-14

**SCHEMATIC DIAGRAMS .....** pages 15-17**SERVICE/WARRANTY INFORMATION**

Shipping Damage .....	page 18
Field Service .....	page 18
Warranty .....	page 18

**REPAIR PARTS LIST .....** page 19

**WARNING: TO REDUCE THE RISK OF FIRE OR ELECTRIC SHOCK,  
DO NOT EXPOSE THIS EQUIPMENT TO RAIN OR MOISTURE.**

---

**DESCRIPTION****GENERAL**

The X<sub>p</sub>200 controller is the electronic "heart" of the Electro-Voice System 200™ modular sound reinforcement system. It links together and enhances the performance of one or more stereo pairs of the S<sub>x</sub>200 full-range speaker systems and one or more S<sub>b</sub>120a (powered) or S<sub>b</sub>120 (nonpowered) bass modules.

Full speaker system details may be obtained by requesting the individual engineering data sheets from Electro-Voice. A few key specifications are given in the Specifications section of this manual (page 3). Typical System 200™ set ups are shown in the Operation and Installation section (pages 8-12).

**Xp200 FEATURE SUMMARY**

- A unique, low-frequency profile circuit enhances low-frequency performance of both the S<sub>x</sub>200 full-range system and the S<sub>b</sub>120a or S<sub>b</sub>120 bass modules.
- In a side-chain circuit, low frequencies are slightly delayed in time as they are boosted, then summed with the original direct signal. This combination of delayed and direct signals changes the relative levels of the musical fundamental and its harmonics, in an audibly attractive way. The resultant modification of timbre is as dynamic and continually changing as the musical input itself.
- A low-frequency profile control adjusts the degree of bass enhancement, up to a maximum of 12 dB. An in/out switch makes it easy to assess the degree of enhancement.
- Input Level and Sub Level controls facilitate easy balancing of a complete System 200™.
- A power/clip LED shows constant green with power on. If clipping occurs, the green is interrupted by flashes of red.
- The full-range, left and right outputs of the X<sub>p</sub>200 feature a 40-Hz, 24-dB-per-octave high-pass filter that keeps the bass output of the S<sub>x</sub>200 speaker systems very tight and clean, by eliminating excessive cone excursion caused by very low, infrasonic frequencies.
- The mono-summed subwoofer output incorporates 24-dB-per-octave filters that roll off response above 134 Hz and below 37 Hz for a high degree of placement flexibility and infrasonic protection for the S<sub>b</sub>120a and S<sub>b</sub>120 bass modules.
- Inputs and outputs are electronically balanced, with 1/4-in. tip-ring-sleeve (TRS) connectors. Two paralleled sub outputs are provided, for easy connection of two subwoofer amplifiers or S<sub>b</sub>120a powered bass modules.
- Outputs are compatible with both balanced and unbalanced loads. A cross-coupled output circuit automatically senses an unbalanced signal connection and increases the gain of the circuit by 6 dB to maintain the same output voltage at the power amplifier input.

## Xp200 SYSTEM CONTROLLER SPECIFICATIONS

**Measurement conditions and notes:**

1. Measurements at 1,000 Hz unless otherwise specified.
2. All level controls full clockwise.
3. 0-dBu input voltage.
4. 18 V ac maintained at power input.
5. 0 dBu = 0.775 V rms.
6. 0 dBm = 1 mW.

**Number of Channels:**

Two

**Front-Panel Controls and Indicators:**

Input level (stereo rotary)  
 Low-frequency profile (stereo rotary)  
 Low-frequency profile in/out switch  
 Subwoofer level (rotary)  
 Power on/clip LED

**Low-Frequency Profile:**

Side-chain equalization circuit summed with direct signal, with up to 12 dB of enhancement at 60 Hz

**Left and Right Main Inputs,****Type:**

Electronically balanced differential

**Impedance:**

30 kilohms

**Maximum Input Level:**

+22 dBu (9.8 V)

**Nominal Input Level:**

0 dBu (0.775 V)

**Connectors:**

1/4-in. tip-ring-sleeve (TRS) phone jacks

**Left and Right Outputs,****Type:**

Electronically balanced, cross-coupled  
 output topology

**Source Impedance:**

150 ohms

**Load Impedance, Recommended/Minimum:**

&gt;1,500 ohms/600 ohms

**Bandwidth:**

40-20,000 Hz (40-Hz, 24-dB-per-octave  
 high-pass filter for infrasonic speaker protection)

**Maximum Output,****Power:**

+19 dBm (79 mW)

**Voltage (15,000-ohm load):**

+22 dBu (9.8 V)

**Nominal Output Power (low-frequency profile switched out):**

0 dBm (1 mW)

**Clipping Indication:**

Green power-on LED interrupted by flashing red  
 at outputs above +19 dBm

**Connectors:**

1/4-in. tip-ring-sleeve (TRS) phone jacks

**Subwoofer Output (monaural, sum of left and right inputs),****Type:**

Electronically balanced, cross-coupled  
 output topology

**Source Impedance:**

150 ohms

**Load Impedance, Recommended/Minimum:**

&gt;1,500 ohms/600 ohms

**Bandwidth:**

37-134 Hz, typical (24-dB-per-octave filters,  
 37-Hz high pass for infrasonic speaker protection  
 and 134-Hz low pass for crossover)

**Maximum Output,****Power:**

+19 dBm (79 mW)

**Voltage (15,000-ohm load):**

+22 dBu (9.8 V)

**Nominal Output Power (low-frequency profile switched out),****0-dBu Signal Applied at 70 Hz to Left and Right Inputs:**

+3 dBm (2 mW)

**0-dBu Signal Applied at 70 Hz to Left or Right Input:**

0 dBm (1 mW)

**Clipping Indication:**

Green power-on LED interrupted by flashing red  
 at outputs above +19 dBm

**Connectors:**

Two paralleled 1/4-in. tip-ring-sleeve (TRS)  
 phone jacks

**Total Harmonic Distortion Plus Noise at 0-dBm Output (40-20,000 Hz):**

&lt;0.1%

**Output Noise, A-Weighted:**

&lt;-90 dBm

**Channel Separation (output on one channel when the other channel is driven at 0 dBu):**

&lt;-85 dBm

**Power Requirements (provided by external plug-in transformer, supplied):**

18 V ac, 200 mA

**Supplied Items and Accessories:**

Owner's manual; rack-mount ears and hardware  
 kit (mounted); pad of rubber feet; external plug-in  
 power supply (120-V, 50/60-Hz PS10 supplied with  
 U.S. units; Xp200 Export supplied to the customer  
 with an appropriate alternate supply)

**Chassis Construction:**

Painted steel

**Colors,****Overall:**

Gray

**Nomenclature,****Front Panel:**

Pearlized light gray

**Top and Rear Panel:**

White

**Dimensions (less rack ears),****Height:** 4.37 cm (1.72 in.)**Width:** 30.5 cm (12.0 in.)**Depth:** 15.2 cm (6.0 in.)**Net Weight (rack ears attached):**

1.56 kg (3.45 lb)

**Shipping Weight:**

2.31 kg (5.10 lb)

Specifications subject to change without notice.

SYSTEM 200™ SPEAKER SYSTEM SPECIFICATIONS (SELECTED)			
	S <sub>2</sub> 200 Full-Range Speaker System	S <sub>b</sub> 120 Nonpowered Bass Module	S <sub>b</sub> 120a Powered Bass Module
Frequency Response (swept sine-wave input, 4 volts at 10 ft on axis, half-space anechoic environment, normalized for 1 meter and a 1-watt speaker input) (see Figures 4, 5 and 6):	80-25,000 Hz	50-500 Hz	50-250 Hz
Usable Low-Frequency Limit with Xp200 Processor (10-dB-down point):	55 Hz	43 Hz	43 Hz
Long-Term Average Power-Handling Capacity per EIA Standard RS-426A:	300 watts	300 watts	N/A (integral, 400-watt amplifier supplied)
Sensitivity (SPL at 1 meter, 1 watt input, anechoic environment, band-limited pink-noise signal over indicated range):	101.5 dB (300-2,000 Hz)	94 dB (50-200 Hz)	N/A
SPL at 1 Meter, Maximum Gain and Amplifier at Clipping Threshold, 0 dBu (0.775 volts) into Balanced Input, Half-Space Anechoic Environment, 50- to 200-Hz Average:	N/A	N/A	120 dB
Dispersion Angle Included by 6-dB-Down Points on Polar Responses, Indicated Bands of Pink Noise, Horizontal and Vertical (see Figure 7):	65° x 65° (2,000-20,000 Hz)	Essentially omni-directional (45-200 Hz)	Essentially omni-directional (45-200 Hz)
Transducer Complement, High Frequency:  Low Frequency:	DH2010A 1-in. compression driver  12-inch Pro-Line	N/A  Long-throw, 12-inch DL12sb	N/A  Long-throw, 12-inch DL12sb
Nominal Impedance:	8 ohms	8 ohms	10,000 ohms (balanced input)
Input Connections:	Two paralleled Neutrik Speakon® NL4MP connectors	Two paralleled Neutrik Speakon® NL4MP connectors	Neutrik all-in-one 3-pin XLR/1/4-in. phone jack
Enclosure Materials and Colors:	Black polypropylene structural foam	Black polypropylene structural foam	Black polypropylene structural foam
Optional Accessories:	100BK mounting stand; Mb200 mounting bracket	100BK mounting stand; Mb200 mounting bracket	100BK mounting stand; Mb200 mounting bracket
Hanging Inserts:	Three metric M6 x 14 mm	Three metric M6 x 14 mm	Three metric M6 x 14 mm
Power Requirements (ac):	N/A	N/A	100 watts maximum average (per UL 813); 100-130 V ac, 50-60 Hz (S <sub>b</sub> 120a); 200-250 V ac, 50-60 Hz (S <sub>b</sub> 120a Export)
Dimensions, Height: Width: Depth:	58.7 cm (23.1 in.) 42.9 cm (16.9 in.) 31.2 cm (12.3 in.)	58.7 cm (23.1 in.) 42.9 cm (16.9 in.) 31.2 cm (12.3 in.)	58.7 cm (23.1 in.) 42.9 cm (16.9 in.) 31.2 cm (12.3 in.)
Net Weight:	17.7 kg (39.0 lb)	14.6 kg (32.2 lb)	15.6 kg (34.4 lb)

*Specifications subject to change without notice.*

**SYSTEM 200™ MODULAR PRO AUDIO**

**Frequency and Beamwidth Response Curves**

**FIGURE 1 — Xp200 Frequency Response, Left and Right Outputs, Profile Control Off (full counterclockwise)**

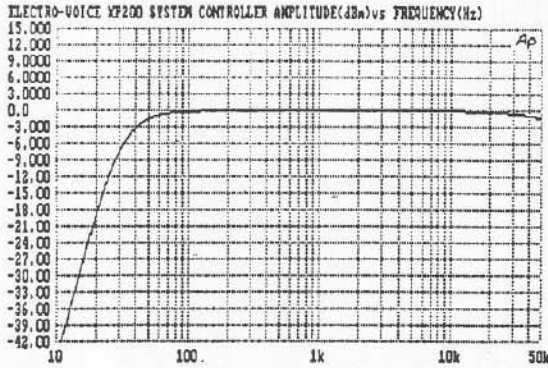

**FIGURE 2 — Xp200 Frequency Response, Subwoofer Output, Profile Control Off (full counterclockwise)**

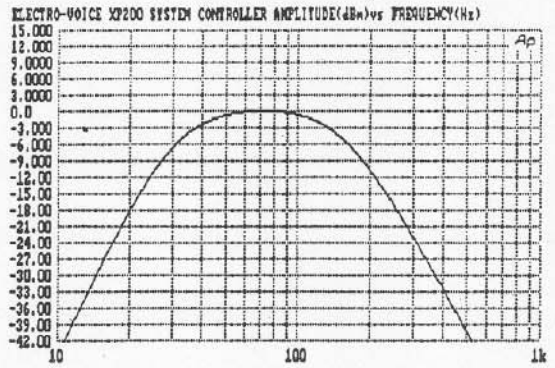

**FIGURE 3 — Xp200 Frequency Response, Left and Right Outputs, Profile Control Advanced to Full Clockwise in 3-dB Steps**

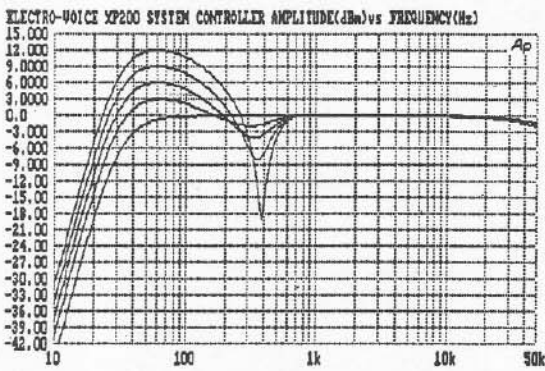

**FIGURE 4 — Sx200 Frequency Response, 1 Watt/ 1 Meter (half-space anechoic environment)**

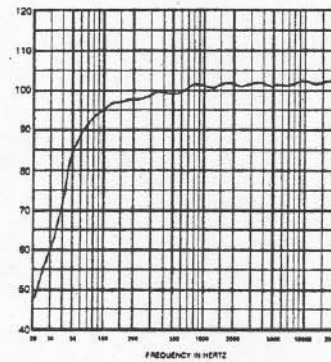

**FIGURE 5 — Sb120 Frequency Response, 1 Watt/ 1 Meter (half-space anechoic environment)**

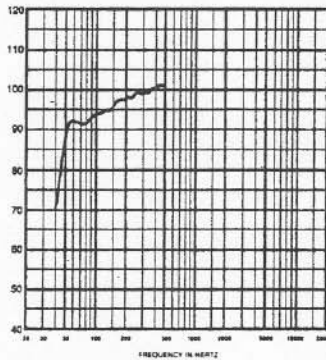

**FIGURE 6 — Sb120a Frequency Response, 1 Watt Into Woofer, 1 Meter (half-space anechoic environment)**

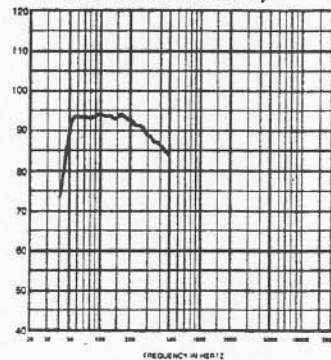

**FIGURE 7 — Sx200 Beamwidth vs. Frequency (anechoic environment)**

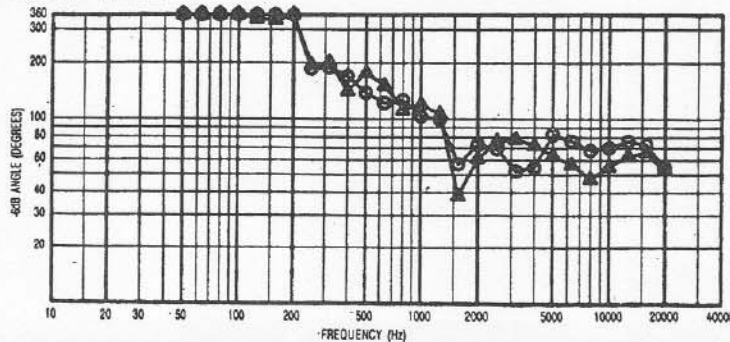

BLOCK DIAGRAM

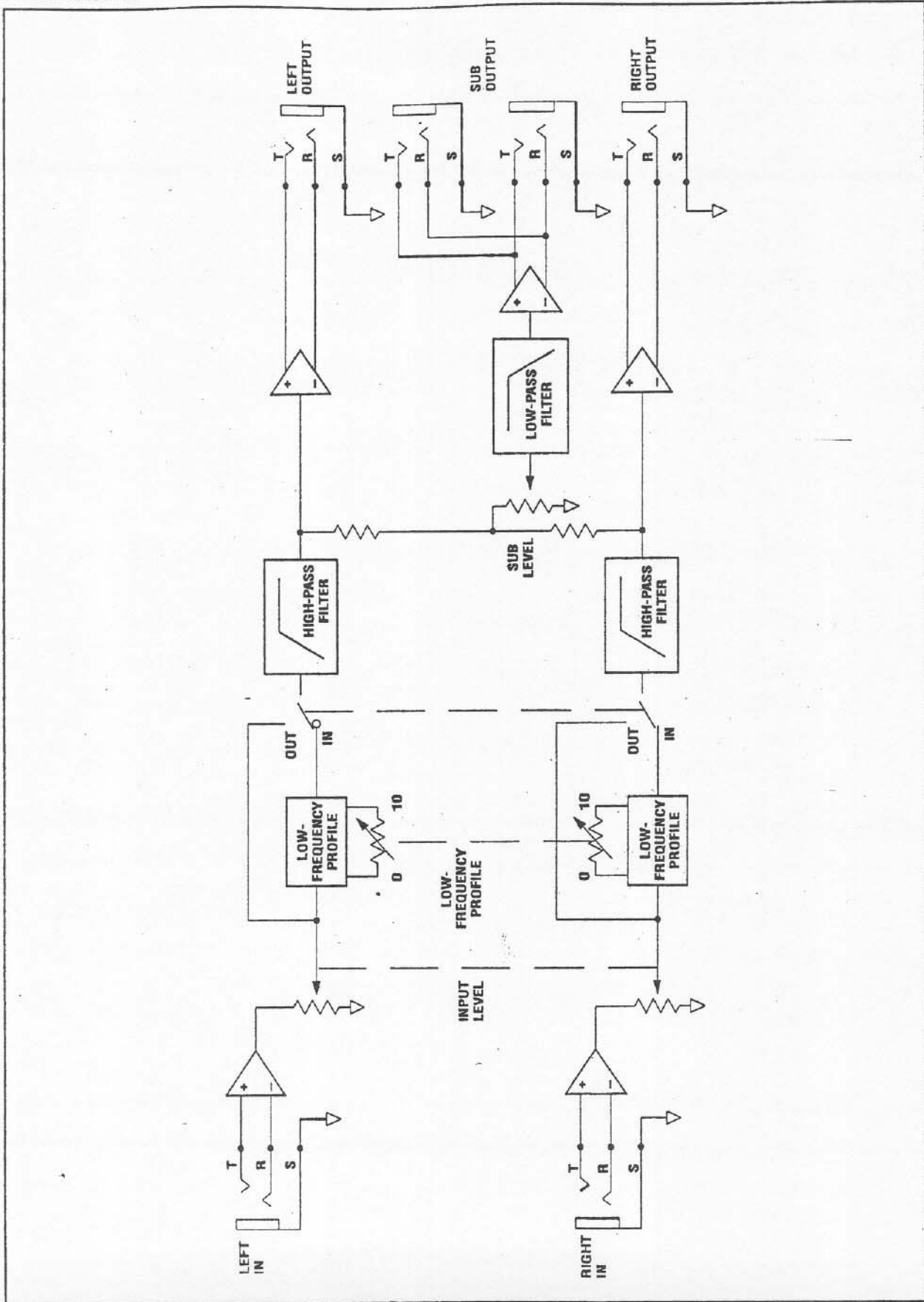
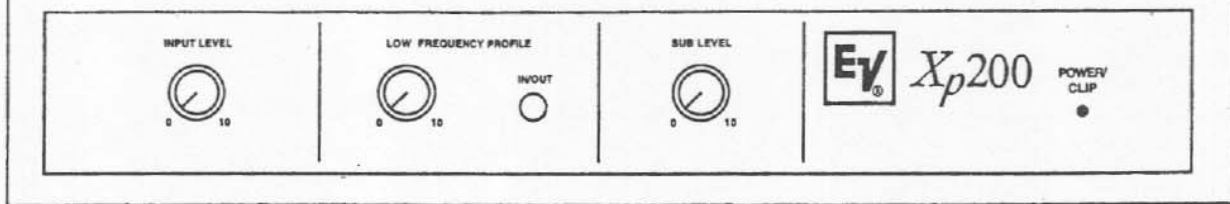

FIGURE 8 — X<sub>p</sub>200 Front Panel (without rack ears)

## OPERATION AND INSTALLATION

### FRONT-PANEL INDICATORS AND CONTROLS

The front-panel layout is shown in Figure 8 and described below:

1. **INPUT LEVEL CONTROL:** this control attenuates the left and right inputs, and thus affects the left, right and subwoofer outputs. Attenuation is zero in the full-on, clockwise position (unity gain). Normally, for best overall system signal-to-noise ratio, this control would be set in the unity-gain position with level reductions made at other points in the signal chain, most likely at the power amplifier.
2. **LOW-FREQUENCY PROFILE CONTROL:** this control adjusts the degree of low-frequency enhancement, from a minimum of zero or off (full counterclockwise) to a maximum of +12 dB (full clockwise). The setting of this control is a matter of taste and is dependant on a variety of factors, including speaker performance characteristics and placement, room acoustics and program material. **Feel free to experiment. A good starting point is a midway setting of the control.**
3. **LOW-FREQUENCY PROFILE IN/OUT SWITCH:** this switch switches the low-frequency enhancement in and out. It makes it easy to assess the effect of changes in the low-frequency profile control.
4. **SUB LEVEL CONTROL:** this control attenuates the subwoofer output. (Keep in mind that the sub level is also affected by the Input

Level control.) With both the sub and input level controls set full on (clockwise) and the profile control off (counterclockwise), overall gain through the Xp200 is unity when a signal is present at **either** the left or right input. For stereo program with common signals in the subwoofer range (a common condition), the sub output will offer 6 dB of gain in the full-on (clockwise) position. (This gain characteristic results because the sub output is derived from a sum of the left and right inputs.)

**There is no "correct" setting of the Sub Level control. Adjust until the bass level and impact are right for your ears/application. The setting may be less than full on, especially if the Low Frequency Profile control is advanced.**

**NOTE:** the S<sub>b</sub>120a powered bass module has a System Gain control on its back panel which attenuates the input signal and thus reduces speaker output much as the X<sub>p</sub>200's Sub Level control does.

5. **POWER/CLIP INDICATOR:** when constant green, this LED indicates power on and undistorted operation. If clipping occurs (+19 dBm output power), the constant green is interrupted by flashes of red.

When clipping is indicated, for best sound quality, one or more X<sub>p</sub>200 rotary controls should be turned down until undistorted operation is once again indicated. For the usual program material, the following sequence is probably best: (1) Low Frequency Profile, (2) Sub Level and (3) Input Level.



FIGURE 9 — Xp200 Back Panel (without rack ears)

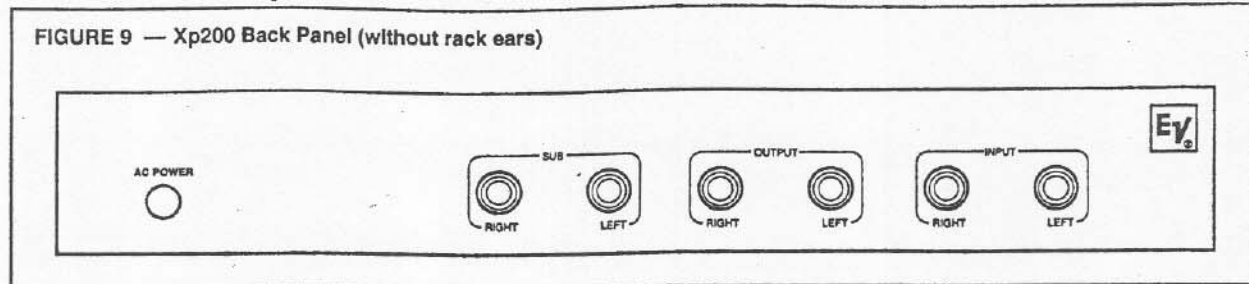

### BACK-PANEL CONNECTIONS

The back-panel layout is shown in Figure 9 and described below:

1. **OUTPUTS (GENERAL):** All outputs are electronically balanced 1/4-in. TRS (tip-ring-sleeve) phone jacks. Either balanced (three circuit) or unbalanced (two circuit) loads may be driven: the Xp200's cross-coupled output topology automatically detects an unbalanced signal connection, and the gain of the circuit is increased by 6 dB to maintain the same output voltage at the power amplifier input.

The outputs of the Xp200 should ideally "see" (be loaded with) 1,500 ohms or more (600 ohms minimum). This is not a difficult condition to meet, since a typical amplifier input impedance is 30,000 ohms. See Connector and Cable Requirements section (pages 13 and 14) for additional wiring information.

2. **SUB OUTPUTS:** These connectors are in parallel and are the subwoofer output, derived from the sum of the left and right inputs, with a bandpass of 37-134 Hz (3 dB down, with 24-dB-per-octave slopes above and below these frequencies). Either one of the outputs should be connected to the input of the subwoofer power amplifier. Alternatively, the output may be connected to the input of an Sb120a powered bass module. The second, paralleled connector simplifies connection to a second power amplifier channel or Sb120a powered bass module. (Also, the Sb120a has two paralleled input connectors, so a second Sb120a may get its signal from the first Sb120a, if that is more convenient.)

The sub outputs are affected by the Sub Level, Input Level and Low Frequency Profile controls.

**NOTE:** If two amplifier channels are connected to the sub outputs, their combined, paralleled load should meet the conditions outlined in Section 2, above. For example, two paralleled 30,000-ohm amplifier inputs present a 15,000-ohm load to the controller output (a reduction of 50 percent).

3. **LEFT AND RIGHT OUTPUTS:** These connectors are the main, full-range/high-passed outputs and should be connected to the main power amplifier channels. With the Input Level control in the full-on, clockwise position, output levels are identical to the input levels, except that response is down 3 dB at 40 Hz with a 24-dB-per-octave roll-off below, for infrasonic speaker protection. The left and right outputs are also affected by the Low Frequency Profile control.
4. **LEFT AND RIGHT INPUTS:** These connectors are for the full-range right and left stereo signal inputs to the Xp200 controller. They are electronically balanced, with a high, 30,000-ohm input impedance, making them compatible with a wide range of sources. See Connector and Cable Requirements section (page 13) for additional wiring information.
5. **AC POWER:** Plug the output connector of the supplied wall-mount power supply into the power jack. (12-volt, 50/60-Hz PS10 for U.S. units. The Xp200 Export is provided with an appropriate alternate supply.) The power/clip LED on the front panel should show green.

### MOUNTING/INSTALLATION

The X<sub>p</sub>200 is supplied with rack-mount ears attached, ready to install in 1 rack unit (1.75 in. high) of an EIA 19-in. rack. While the overall depth behind the front panel is about 15.2 cm (6.0 in.), about 5.1 cm (2.0 in.) of additional depth must be provided for typical connector/cable clearance.

For stand-alone mounting, each rack ear may be dismantled, by removing four Phillips-head screws. The two bottom screws must be reinstalled, since they help hold the cover to the chassis. The four rubber feet supplied may be installed on the bottom of the X<sub>p</sub>200.

### TYPICAL SYSTEM 200™ MODULAR PRO AUDIO CONFIGURATIONS

The X<sub>p</sub>200 controller will enhance the performance of one or more pairs of S<sub>x</sub>200 full-range speaker systems used alone, or the performance of S<sub>x</sub>200's used in combination with one or more S<sub>b</sub>120a (powered) or S<sub>b</sub>120 (nonpowered) bass modules.

#### Amplifier Power Recommendations

The power amplifiers shown in Figures 10 through 13 are typical, relatively conservative choices: different output power ratings are quite workable, including larger ratings:

1. To use a speaker system to full capacity, skilled experts in sound system installation and operation will obtain the best results if the power amplifier is 2.0 to 4.0 times the long-term average noise power rating of the speaker system. For the S<sub>b</sub>120 and S<sub>x</sub>200 systems, this is 600 to 1,200 watts.

The **caution** cannot be made strongly enough, however, that **this arrangement is only for experts** or for those who can discipline themselves against "pushing" the system for ever-higher sound levels and who can avoid "accidents" such as catastrophic feedback or dropped microphones.

2. A more conservative, "nominal" amplifier size, which will produce audible results nearly equal to those of the "expert" recommendation, is 1.0 to 1.4 times the long-term average noise power rating of the speaker. For the S<sub>b</sub>120 and S<sub>x</sub>200 speaker systems, this is 300 to 420 watts.
3. To be very conservative, one can use an amplifier rated at 0.5 to 0.7 times the long-term average rating of the loudspeaker. For the S<sub>b</sub>120 and S<sub>x</sub>200 speaker systems, this is 150 to 210 watts.

Request P.A. Bible Addition No. Two ("Power Handling Capacity") for more background on these recommendations.

#### Configurations Shown

Figure 10 shows the most basic setup: a pair of S<sub>x</sub>200's. In this setup, the X<sub>p</sub>200 provides low-frequency enhancement and infrasonic speaker protection for the S<sub>x</sub>200's.

Figure 11 shows how to add one or two S<sub>b</sub>120a powered bass modules. (The second module and its connection are shown in grey.)

Figure 12 shows how to add one S<sub>b</sub>120 nonpowered bass module.

Figure 13 shows how to add two S<sub>b</sub>120 nonpowered bass modules.

FIGURE 10 — Basic Hookup of the Xp200 Controller and a Pair of Sx200 Full-Range Speaker Systems

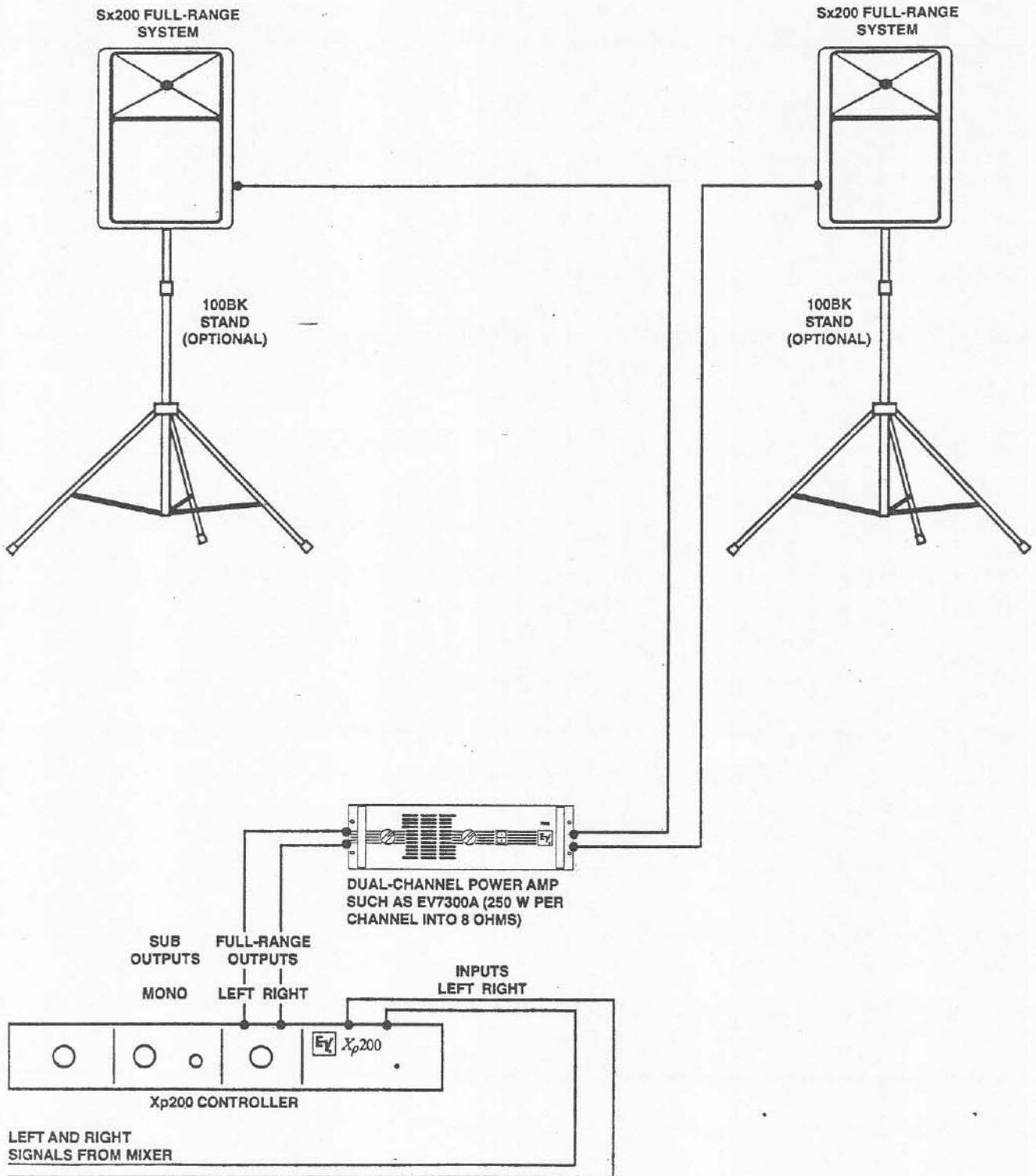

FIGURE 11 — Hookup of an Xp200 Controller with a Pair of Sx200 Full-Range Speakers and One or Two Sb120a Powered Bass Modules

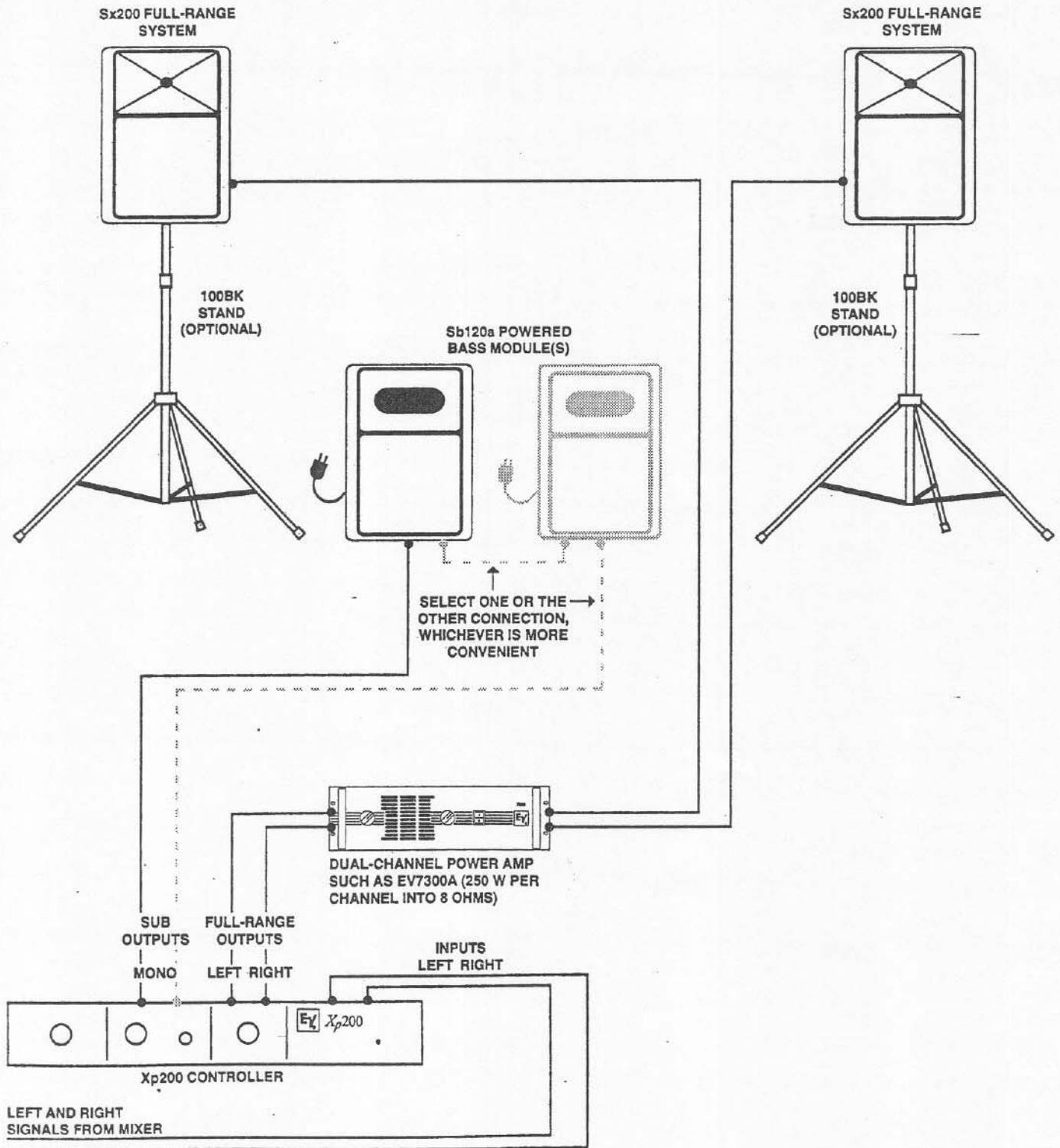

FIGURE 12 — Hookup of an Xp200 Controller and a Pair of Sx200 Full-Range Speakers and One Sb120 Nonpowered Bass Module

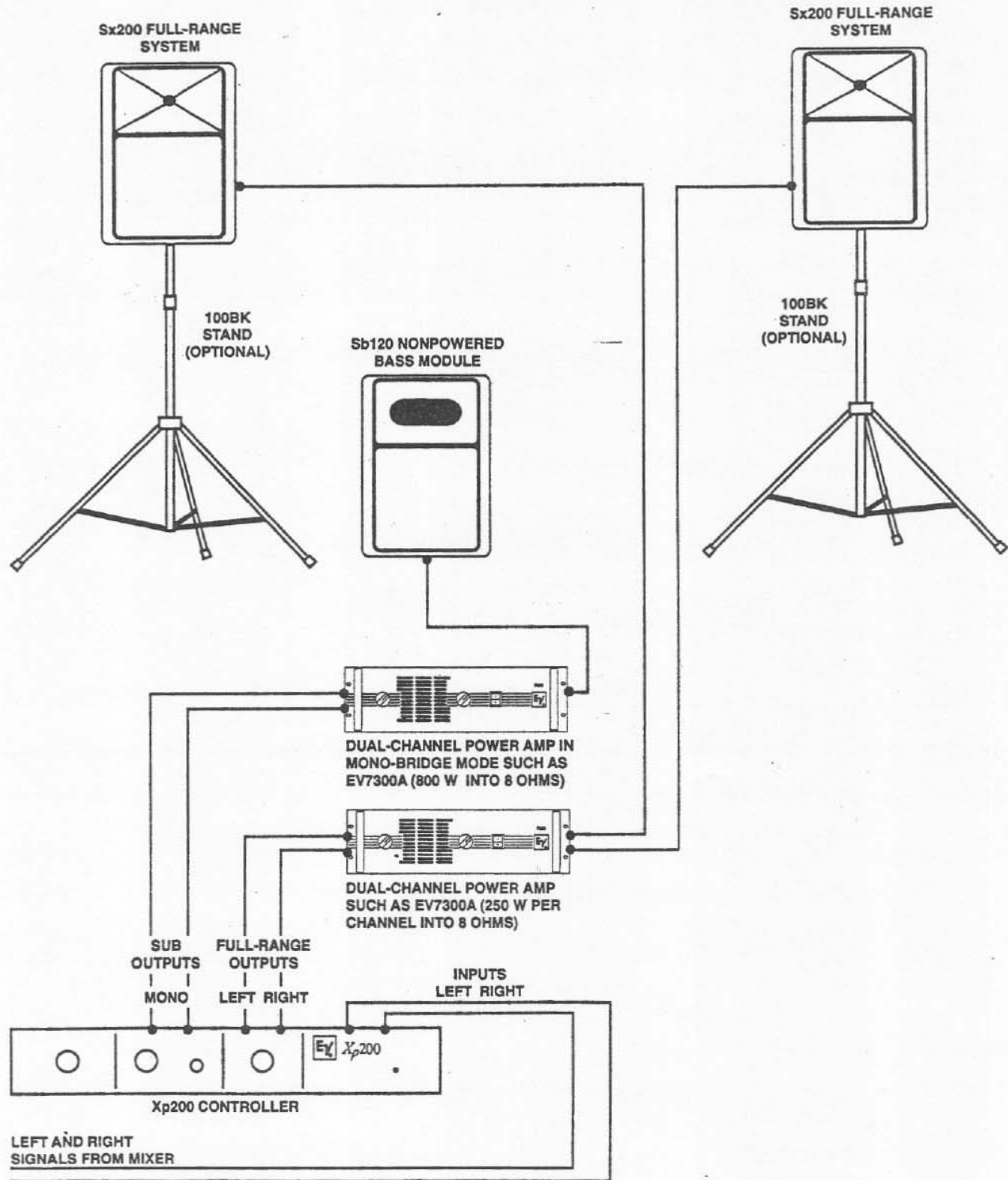
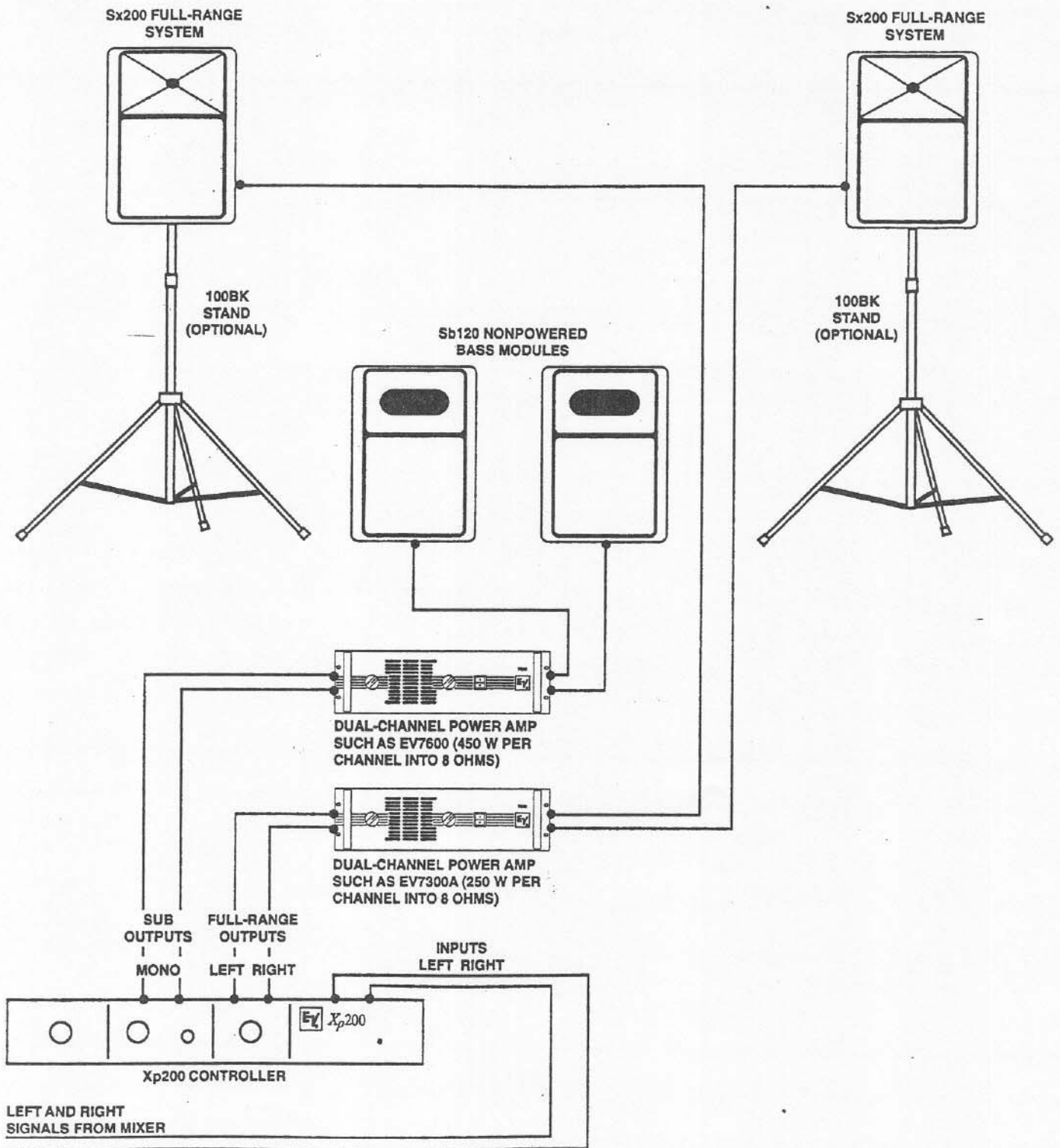

FIGURE 13 — Hookup of an Xp200 Controller and a Pair of Sx200 Full-Range Speakers and Two Sb120 Nonpowered Bass Modules



## CONNECTOR AND CABLE REQUIREMENTS

X<sub>p</sub>200 Input Connections

The X<sub>p</sub>200 is compatible with both balanced and unbalanced signal sources.

**Balanced Sources:** Balanced signal sources are least susceptible to noise and should be used when possible. Figure 14A shows a 1/4-inch tip-ring-sleeve (TRS) plug used with two-conductor shield cable. This arrangement is appropriate for long runs, up to and beyond 100 feet. Note that the cable shield is not connected to the connector sleeve at the X<sub>p</sub>200 input. This prevents the formation of ground loops, a major source of hum and noise.

**Unbalanced Sources:** For long cable runs from unbalanced sources (greater than about six feet and up to about 100 feet), the connection shown in Figure 14B is preferred, because it is least susceptible to noise. Note that a standard two-circuit, 1/4-inch phone plug is used with two-conductor shielded cable. Also, one of the inner conductors is connected to the cable shield at the source but is not so connected at the input to the X<sub>p</sub>200. Figure 14C shows how a TRS phone plug may be substituted for the standard plug, as long as the sleeve and ring are connected together within the connector.

For short unbalanced cable runs (up to six feet), the simpler and more conventional connection of Figure 14D may be used. A standard, two-circuit 1/4-in. phone plug is used with single-conductor shielded cable. Figure 14E shows how a TRS phone plug may be substituted for the standard plug, as long as the sleeve and ring are connected together within the connector.

X<sub>p</sub>200 Output Connections

**Balanced Loads:** Power amplifiers with balanced inputs are the least susceptible to noise, and should therefore be used when possible. Figures 15A and 15B show an appropriate cable configuration, with a 1/4-inch tip-ring-sleeve (TRS) plug on the X<sub>p</sub>200 end and connections for a 1/4-in. TRS plug and a 3-pin XLR-type plug, respectively, at the amplifier end. (The S<sub>b</sub>120a powered bass module accepts either type.) Note that two-conductor shielded cable is used throughout. Also, note that the cable shield is not connected to the connector sleeve at the power amp input. This prevents the formation of ground loops, a major source of hum and noise.

**Unbalanced Loads:** When unbalanced power amplifiers must be used, the cable shown in Figure 15C is recommended for the lowest noise and long runs (up to about 100 feet). Note that two-conductor shielded cable is used and that the shield is not connected at the X<sub>p</sub>200 end but is connected to ground at the amplifier end. The X<sub>p</sub>200's cross-coupled output topology increases the gain of the circuit by 6 dB, keeping the X<sub>p</sub>200's output voltage the same at the power amplifier input.

For short runs to unbalanced amplifiers (up to about six feet), a standard two-circuit 1/4-in. phone plug on each end of a single-conductor shielded cable may be used. See Figure 15D. The X<sub>p</sub>200's cross-coupled output topology increases the gain of the circuit by 6 dB, keeping the X<sub>p</sub>200's output voltage the same at the power amplifier.

S<sub>x</sub>200 and S<sub>b</sub>120 Speaker System Connections

The S<sub>b</sub>120 and S<sub>x</sub>200 are equipped with two paralleled Neutrik Speakon® NL4MP connectors,

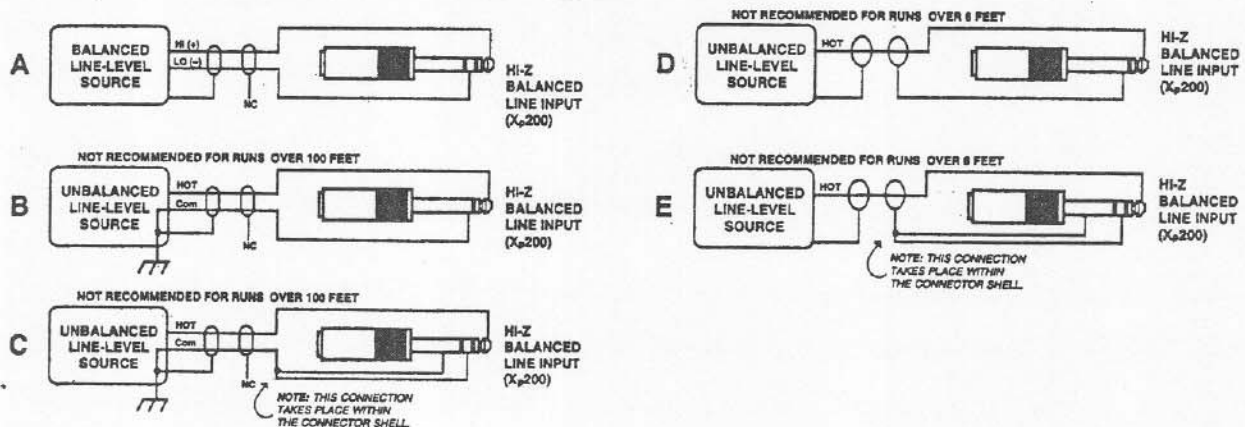
FIGURE 14 — Connecting the X<sub>p</sub>200 Controller to the Signal Source

selected for their ability to reliably deliver to the speaker components the high currents delivered by high-wattage power amplifiers. An NL4FC mating connector is supplied with each system. The NL4FC is a four-pin connector, and Figure 16 shows how the usual two-conductor speaker cable should be wired to pins 1+ and 1-. Two typical connectors at the power amplifier end of the cable are shown: banana and 1/4-inch phone plugs. (The banana plug provides the more reliable connection.)

Note also that Neutrik Speakon® cables, connectors and wiring accessories are available from Pro Co Sound, Inc., and Whirlwind Music Distributors, Inc. To find your local Pro Co, Whirlwind or Neutrik dealer, contact:

Pro Co Sound, Inc.  
135 E. Kalamazoo Ave.  
Kalamazoo, MI 49007  
616/388-9675

Whirlwind Music Distributors, Inc.  
P.O. Box 1075  
Rochester, NY 14603  
716/663-8820

Neutrik USA, Inc.  
195-S3 Lehigh Ave.  
Lakewood, NJ 08701  
908/901-9488

FIGURE 15 — Connecting the Xp200 Controller to Power Amplifiers and the Sb120a Powered Bass Modules

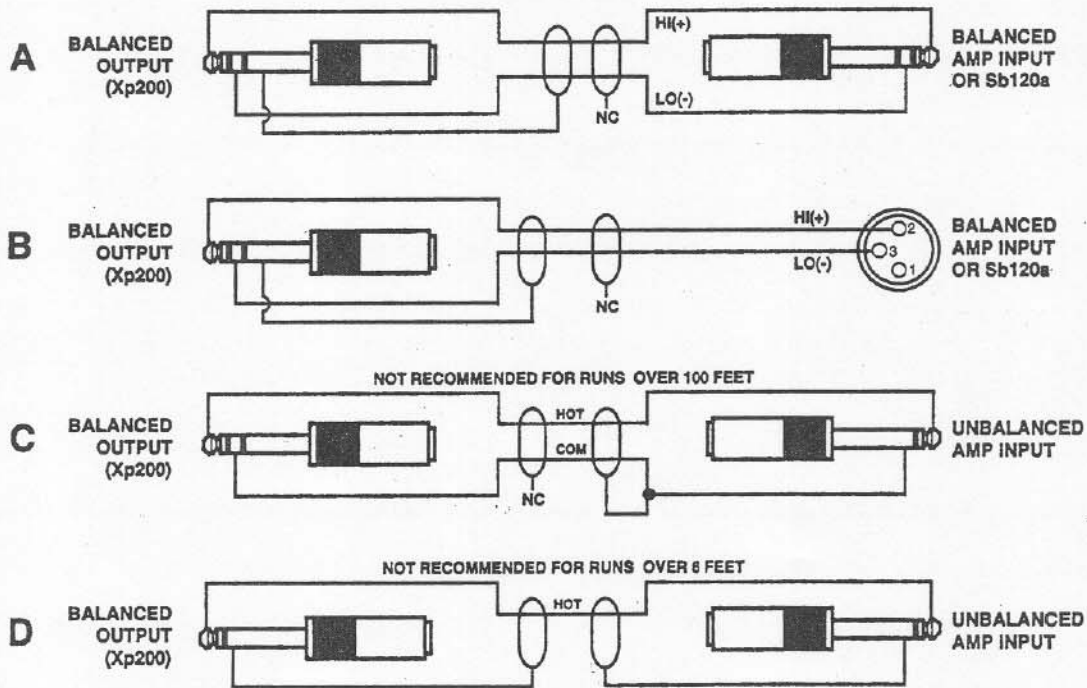
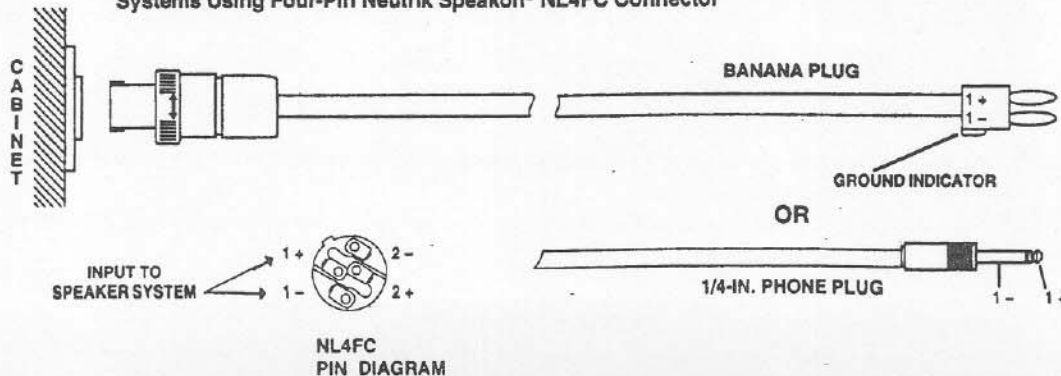
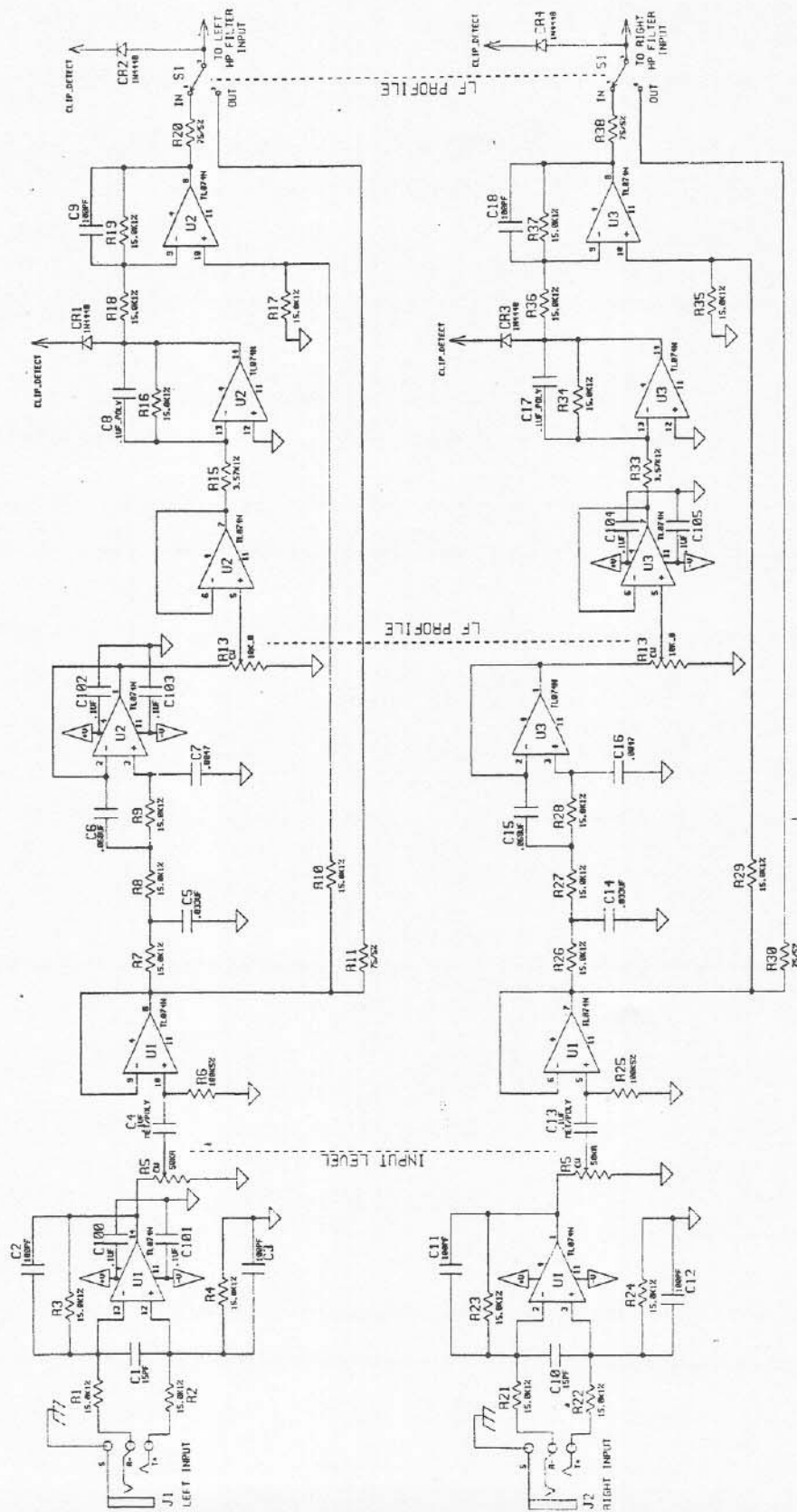
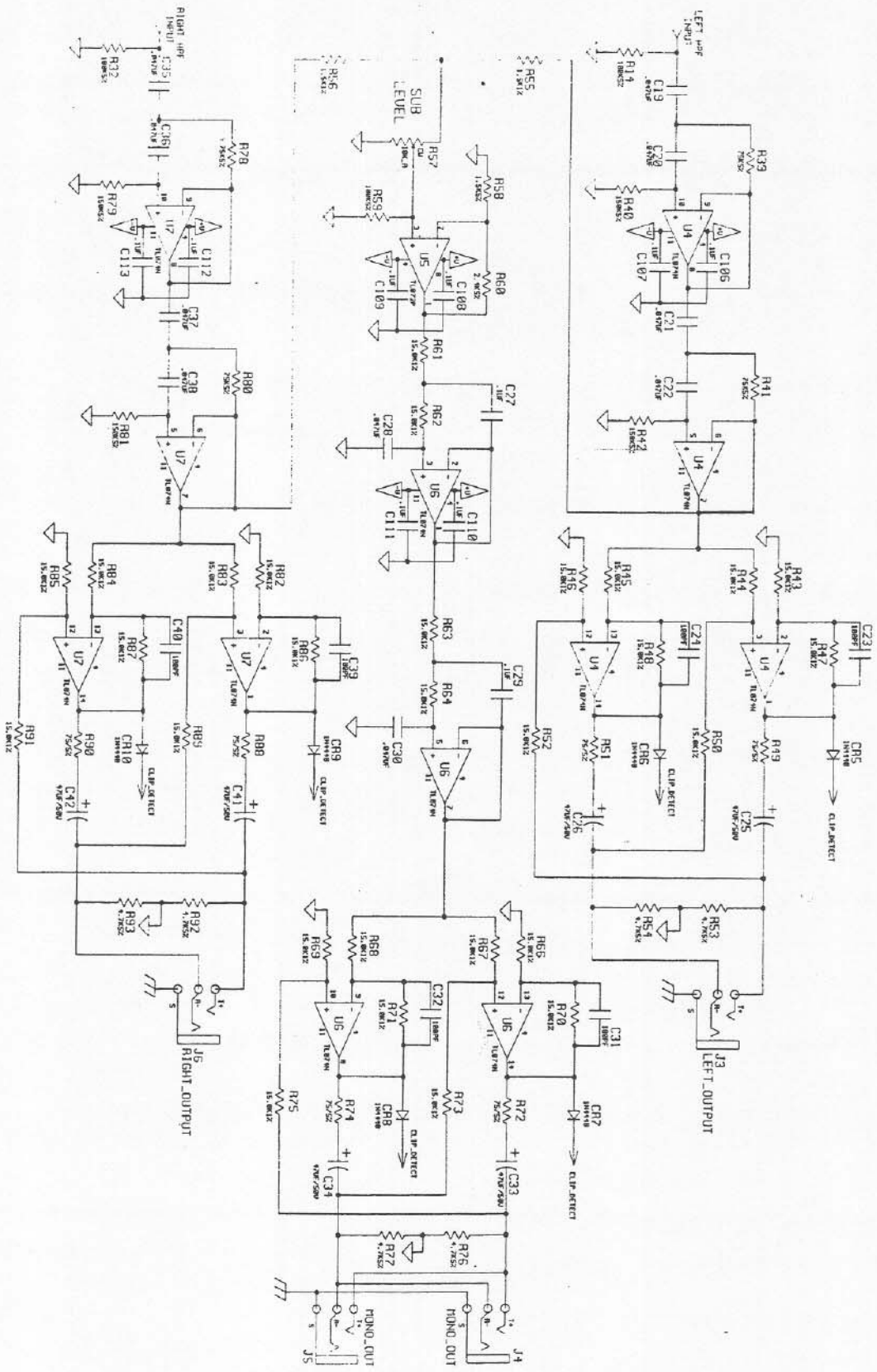

FIGURE 16 — Two-Conductor Cable Configurations for S<sub>x</sub>200 and S<sub>b</sub>120 Speaker Systems Using Four-Pin Neutrik Speakon® NL4FC Connector









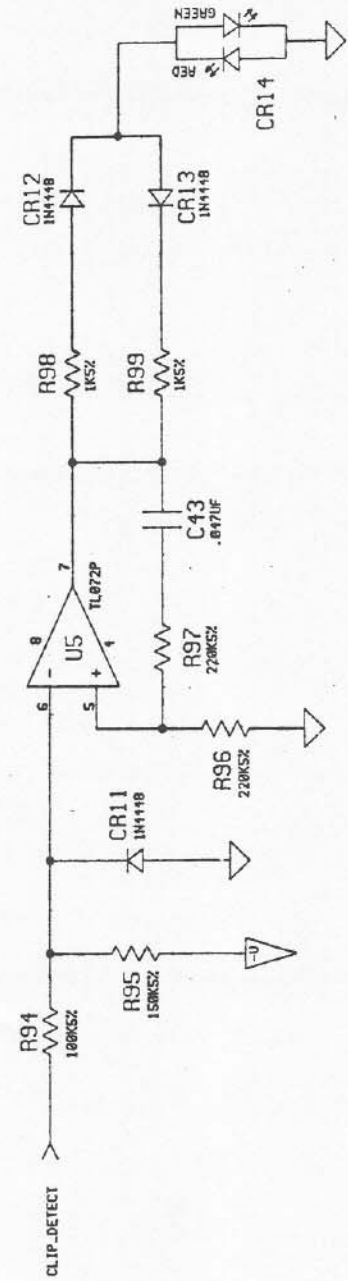
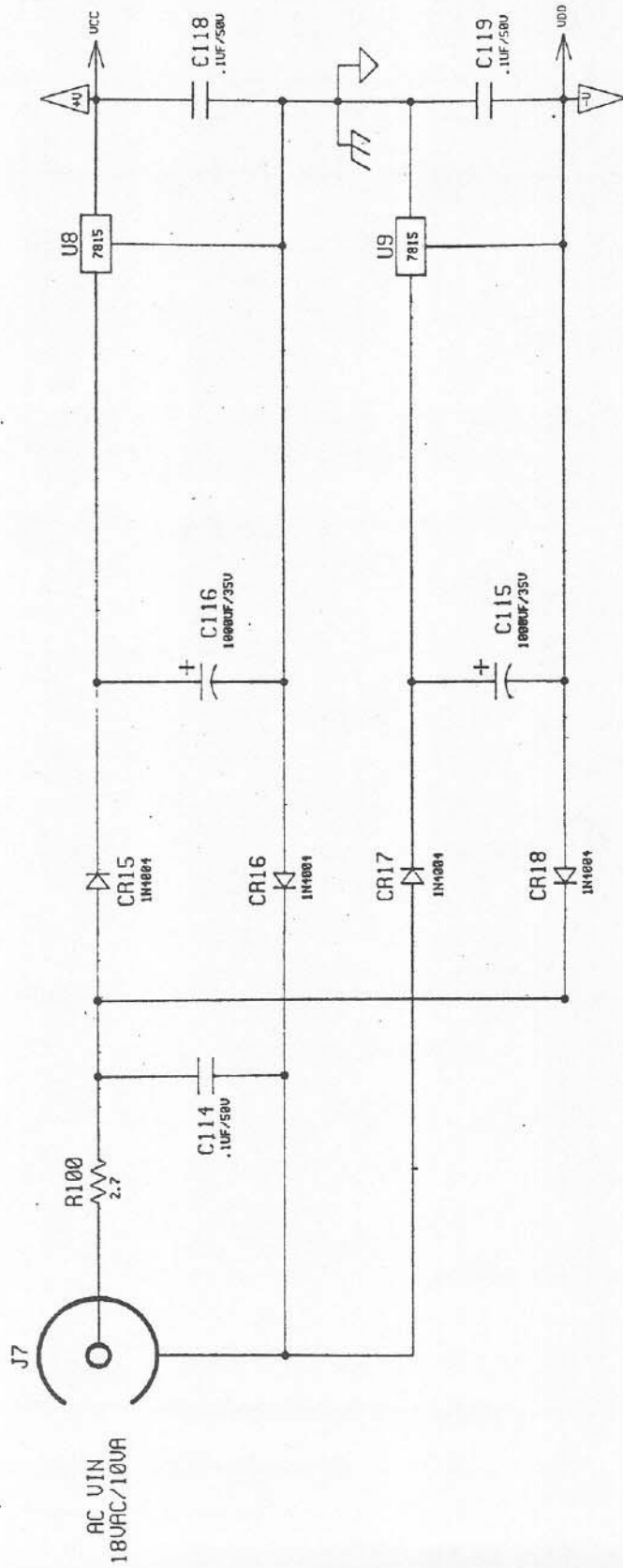

**SERVICE/WARRANTY INFORMATION****SHIPPING DAMAGE**

Inspect the shipping carton for possible damage. If damage is found, notify the transportation company immediately. Save the carton as evidence for the carrier to inspect. If damage occurs during shipping, it is the responsibility of the consignee to file a claim with the carrier. If the carton is in good condition but the unit is damaged, call Electro-Voice.

Included in the box with the X<sub>p</sub>200 controller are rack-mount ears and hardware kit (mounted), pad of rubber feet, an external, plug-in power supply, Product Evaluation Questionnaire and this manual.

**FIELD SERVICE****Controller Power Inspection**

If the X<sub>p</sub>200 power indicator does not light, check the power supply connections.

**WARRANTY (Limited)**

Electro-Voice products are guaranteed against malfunction due to defects in materials or workmanship for a specified period, as noted in the individual product-line statement(s) below, or in the individual product data sheet or owner's manual, beginning with the date of original purchase. If such malfunction occurs during the specified period, the product will be repaired or replaced (at our option) without charge. The product will be returned to the customer prepaid. **Exclusions and Limitations:** The Limited Warranty does not apply to: (a) exterior finish or appearance; (b) certain specific items described in the individual product-line statement(s) below, or in the individual product data sheet or owner's manual; (c) malfunction resulting from use or operation of the product other than as specified in the product data sheet or owner's manual; (d) malfunction resulting from misuse or abuse of the product; or (e) malfunction occurring at any time after repairs have been made to the product by anyone other than Electro-Voice or any of its authorized service representatives. **Obtaining War-**

**ranty Service:** To obtain warranty service, a customer must deliver the product, prepaid, to Electro-Voice or any of its authorized service representatives together with proof of purchase of the product in the form of a bill of sale or receipted invoice. A list of authorized service representatives is available from Electro-Voice at 600 Cecil Street, Buchanan, MI 49107 (616/695-6831 or 800/234-6831) and/or Electro-Voice West, at 8234 Doe Avenue, Visalia, CA 93291 (209/651-7777 or 800/825-1242). **Incidental and Consequential Damages Excluded:** Product repair or replacement and return to the customer are the only remedies provided to the customer. Electro-Voice shall not be liable for any incidental or consequential damages including, without limitation, injury to persons or property or loss of use. Some states do not allow the exclusion or limitation of incidental or consequential damages so the above limitation or exclusion may not apply to you. **Other Rights:** This warranty gives you specific legal rights, and you may also have other rights which vary from state to state.

**Electro-Voice Speakers and Speaker Systems** are guaranteed against malfunction due to defects in materials or workmanship for a period of five (5) years from the date of original purchase. The Limited Warranty does not apply to burned voice coils or malfunctions such as cone and/or coil damage resulting from improperly designed enclosures. **Electro-Voice Electronics** are guaranteed against malfunction due to defects in materials or workmanship for a period of three (3) years from the date of original purchase. **Electro-Voice Flying Hardware** (including enclosure-mounted hardware and rigging accessories) is guaranteed against malfunction due to defects in materials or workmanship for a period of one (1) year from the date of original purchase. Additional details are included in the Uniform Limited Warranty statement.

Service and repair address for this product: Electro-Voice, Inc., 600 Cecil Street, Buchanan, Michigan 49107 (616/695-6831 or 800/234-6831).

Specifications subject to change without notice.

## REPAIR PARTS LIST

## CIRCUIT BOARD ASSEMBLY (27-01-039395)

Reference Designator	Part Number	Description
R1-4,7-10,16-19,21-24,26-29,34-37,43-48 50,52,61-64,66-69	47-03-124484	Res 15.0 k Ohm/1%/.25W Met Film Ax
R5 - Input Level	47-06-039348	Pot 10 k Ohm/Dual/ Taper A
R6,14,25,32,59,94	47-01-102127	Res 100 k Ohm/5%/.25W Car Film Ax
R11,20,30,38,39,41,44,51,72,74,75,78,80, 88,90	47-01-102051	Res 75 Ohm/5%/.25W Car Film Ax
R13 - Low Frequency Profile Level	47-06-039346	Pot 10 k Ohm/Dual/ Taper B
R15,33	47-03-124651	Res 3.57 k Ohm/1%/.25W Met Film Ax
R40,42,79,81,95	47-01-102131	Res 150 k Ohm/5%/.25W Car Film Ax
R53,54,76,7,92,93	47-01-102094	Res 4.7 k Ohm/5%/.25W Car Film A
R55,56,58	47-03-124669	Res 1.50 k Ohm/1%/.25W Met Film Ax
R57 - Sub Outout Level	47-06-039347	Pot 10 k Ohm/Single/0Taper A
R60	47-01-102087	Res 2.4 k Ohm/5%/.25W Car Film Ax
R96,97	47-01-107043	Res 220 k Ohm/5%/.25W Car Film Ax
R98,99	47-01-102078	Res 1 k Ohm5%/.25W Car Film Ax
R100	47-01-102016	Res 2.7 Ohm/5%/.25W Car Film Ax
C1,10	15-02-029032	Cap 15 pF/10%/50V Cer Disk Rad
C2,3,9,11,12,18,23,24,31,32,39,40	15-06-037468	Cap 100 pF/630V/ Polyprop Ax
C4,13,27,29	15-06-124637	Cap .1 uF/5%/100V/ Poly Rad
C5,14	15-06-028021	Cap .033 uF/10%/50V Mylar Rad
C6,15	15-06-028023	Cap .068 uF/10%/50V Mylar Rad
C7,16	15-06-124611	Cap .0047 uF/5%/100V Mylar Rad
C8,17	15-06-037653	Cap .1 uF/2%/100V Poly Rad
C19-22,28,30,35-38,43	15-06-027367	Cap .047 uF/5%/50V Mylar Rad
C25,26,33,34,41,42	15-01-026641	Cap 47 uF/50V Al Elec Rad
C100-114,118,119	15-02-124437	Cap .1 uF/50V Cer Disk Rad
C115,116	15-01-027317	Cap 1000 uF/35V AL Elec Rad
CR1-13	48-01-122601	Dio 1N4448 75V/10mA/.5W
CR14	39-01-039375	Led Dual, Red/Grn
CR15-18	48-02-042787	Dio 1N4004 400V 1A
U1-4,6,7	17-01-124461	IC TL074CN Op Amp, Quad
U5	17-01-124688	IC TL072CP Op Amp, Dual
U8,9	17-01-121660	IC MC7815CT Reg, +15VDC
J1-6	21-01-029039	Conn Phone Jack, .25 inTRS
J7	21-01-125001	Conn Jack, AC IN
S1	51-02-124479	Sw PB, PC Mnt/DPDT

## ASSORTED OTHER PARTS

Wall Transformer	56-08-039396	Xfmr Ext, Plug-in PS10 18VAC/10VA
Control Knobs	24-04-038872	Knob Body-Blk/Cap-Blk/Line-Wh (3 required)
Switch Knob	24-04-039407	Knob Push-Button, Blk
Rubber Foot	24-09-027383	Foot, Rubber, Blk (4 required)
Hdw Kit	28-13-026422	Rack mount hardware kit
Brkt, Rack Mnt	14-08-039405	Rack mount ear (2 required)
4-40 x 1/4 Rolox screw	28-01-124701	Secures front panel to cover (3 required)
6-32 x 5/16 Rolox screw	28-01-125083	Secures sides (4/side) and rear panel (3); (11 required)
6-32 x 1/4 machine screw	28-01-115517	Secures PCB to chassis (6 required)

