

# Service Manual

200MB

# Table of Contents

Operating Instructions	3
Turn On / Calibration Procedure	6
Schematics	9
Engineering Change Orders (ECOs)	18
Bill of Materials	19

## Operating Instructions 200MB/200RCB

### The Basics

Your new G-K Bass amplifier represents the latest advances technology has to offer. With a built in limiter, chorus, 4 band EQ, two voicing filters and a master volume; the number of different sounds available is endless.

A careful examination of this manual will help you get the most from them.

LEFT TO RIGHT ON THE FRONT PANEL

### Input Jack

The input jack is a standard 1/4" jack capable of handling a wide variety of signal levels up to 9v RMS.

### Volume

This knob controls preamp volume and limiter threshold. This will control your overdrive sound or sustain when limiter is on.

### Voicing Filters

The contour switch "rounds" out the tone by putting a dip in the midrange frequencies and boosting the bass and treble.

The high-boost switch boosts the high frequencies for a brighter sound. Also can be used to "liven" up old and worn strings.

### 4 Band EQ

1. The first knob is an active treble control operating at 4.0 kilohertz. It adds high end and brightness to your sound.
2. The second knob is an active high mid-range control operating at 1.0khz. This controls the punch and definition of your tone.
3. The third knob is an active low mid-range operating at 250hz. This adds to the meat or body of your sound.
4. The last EQ knob is an active bass control operating at 60hz. This controls the bottom end or boom of your sound.

### Limiter

With the master up full the limiter will prevent the power amp from distorting.

With the master on lower settings, the limiter will give you smooth distortion free sustain, with the level controlled by the master setting. Raising the volume level increases sustain.

It is possible to drive the preamp into distortion by raising the volume control too high, even when the limiter is on.

### Master

The master volume controls the total output from off to full power.

### Chorus on/off

The chorus is a fully adjustable, studio quality effect unit built right into your amp. It incorporates a high technology IC chip to give a full chorus enhancement of your sound.

### Phones

The phones jack is a 1/4" stereo jack. It delivers a stereo signal for use with high impedance head phones (600 ohm or greater). Plugging into the phones jack does not disconnect the speakers. To disconnect the speakers use the switch on the rear panel.

### Effects Loop

The effects loop is provided for the insertion of external effects. It is post EQ and pre internal effects. Using standard guitar cords, connect the send of the amp to the input on the effect unit; connect the output of effect to the return on the amp. The level is 150 mv with master up full.

### Direct Outs

Both wet and dry low impedance direct outs are provided with your amp for professional recording capabilities. The wet direct signal contains effects and is controlled by the master volume. The dry direct has no effects and is not affected by the master volume.

### Internal Speaker on/off (200MB)

You have the ability to turn off the internal speaker with this switch.

### External Speaker Jack

This jack is for use with an external speaker cabinet. With the internal speaker on, you can add an 8 ohm load. With the internal speaker off, you can add a 4 ohm load.

### Power Switch

The power switch on the 200MB is on the rear panel. The power switch on the 200RCB is on the front panel lower right.

### Power Cord

The power cord is detachable and plugs into a socket on the rear panel. If a replacement cord is used or needed it should be UL rated at 10 amp, 125v; or if using 240v, the cord should be UL rated at 5 amp, 240v.

### Fuse

Never operate your MB or RCB with any other than the recommended fuse.

115v operation – type TSC2A  
240v operation – type TSC1A

### Maintenance

Your new amplifier is rugged. It was built to give you a lifetime of trouble free operation. If it is operated with care, your only maintenance problems should be cleaning. We recommend a soft damp cloth and mild soap for cleaning outside surfaces. Your amp can be serviced at any GK authorized service center or at the GK factory if needed.

# Extension Speakers

200MB

With Internal Speaker On

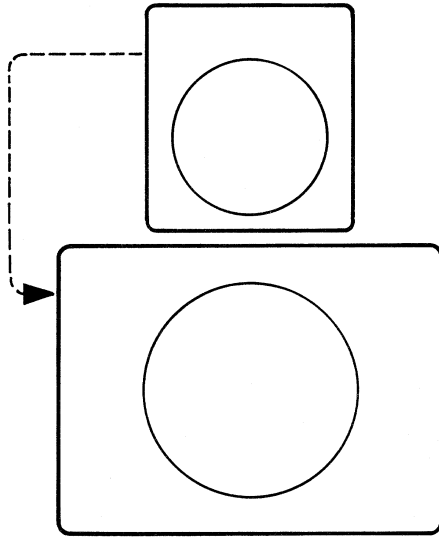

8 ohms

With Internal Speaker Off

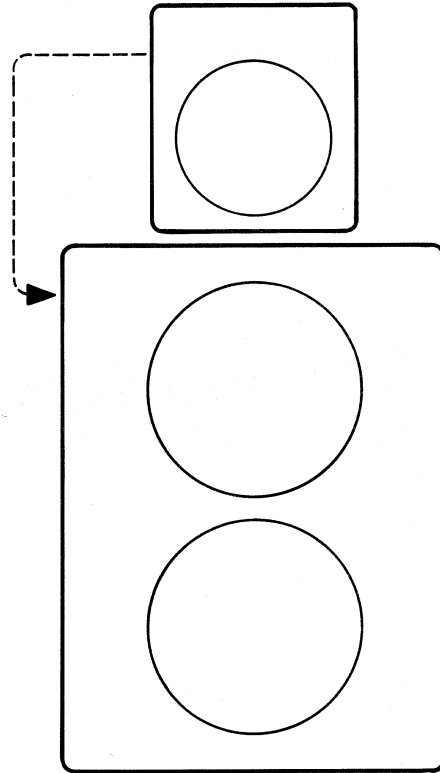

4 ohms

200RCB

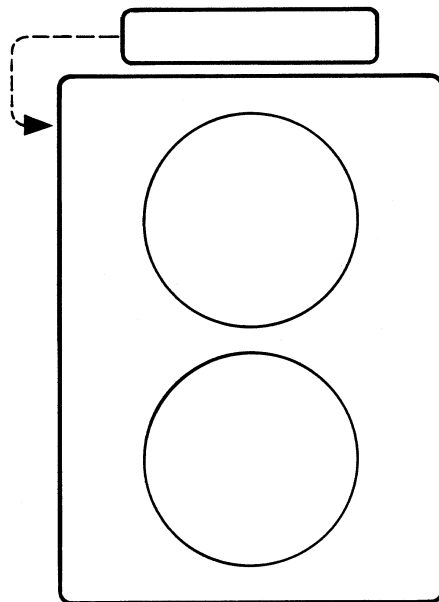

4 ohms

## 200MB MIC STAND BRACKET

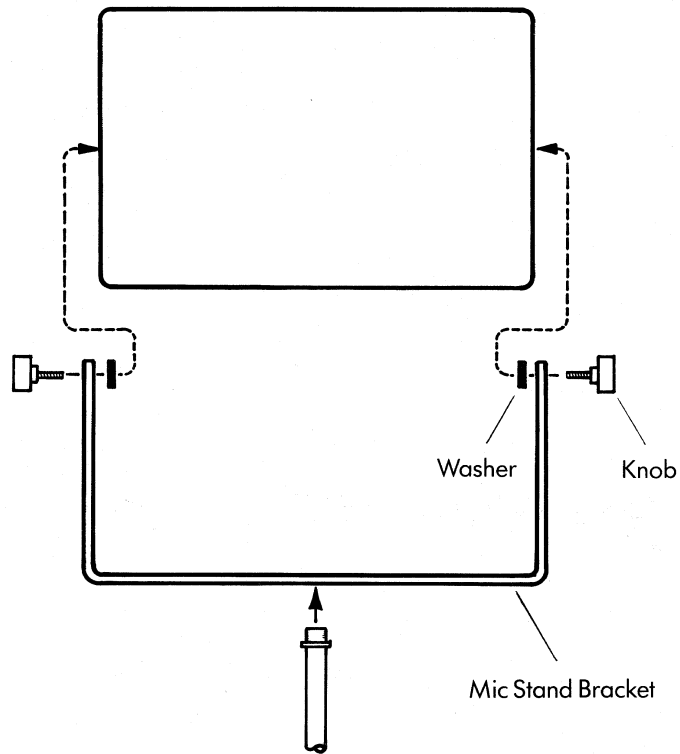

Standard Mic Stand Thread  
(5/8 - 27)

### 200MB & 200RCB Specifications

**Max Input Level**

9v rms

**Sensitivity (400hz)**

4mv

**Power**

100w @ 4 ohms

**Effects Send**

750mv rms into 22k for full power

**Effects Return**

750mv rms into 12k for full power

**Extension Speakers**

200MB 8 ohms with internal spkr on  
4 ohms with internal spkr off

200RCB 4 ohms

	200MB	200RCB
<b>Weight</b>	241 lbs.	10 lbs.
<b>Dimensions</b>	13.75" x 15"	17.5" x 3.5"
<b>Speakers</b>	1 x 12"	N/A

## 200MB/RCB T/O Procedure

Rev.B- 3/7/88

- 1) Inspect board.
- 2) Connect mains.
- 3) Observe the following:
  - A) no load
  - B) variac at 0
  - C) trim pots halfway
  - D) tones on 5
  - E) volume on 0
  - F) master on 0
  - G) switches out
  - H) sustain on 0
  - I) chorus depth on 0
  - J) chorus rate on 0
  - K) speaker on
- 4) Gradually adjust variac to 25 Vrms.  
U20/P4= -1.5V (+or-)-.5V. U20/P8= 3.2V (+or-) -.5V.  
Regulated supplies = -.5 V (+or-) .5V./ 7.1V (+or-) -.5V.
- 5) Gradually adjust variac to 70Vrms while listening to the speaker and watching variac (AC amps) and scope. Output should go -8V then +10V, motor a little and settle at 0 between 50-60Vrms.  
Regulated supplies = -14.3V (+or-) .5V/ 14.2V (+or-) .5V.
- 6) Adjust variac to 120Vrms and turn speaker off. Supply voltage (+or-)46.5V (+or -).5V.
- 7) Set bias. Adjust R207 to get 5mV across R197, R208 ( most pos. of the two), and R223, R224 (the most neg. of the two).
- 8) Set the following: master on 10.
- 9) Connect sine input (400Hz 50mVrms) -26 dB.
- 10) Compressor test.
  - A) Volume on 10.
  - B) Sustain on 0. U2/P6= 700mVp-p. U4/P7= 2.3Vp-p.
  - C) Engage compressor. U4/P7= 1.2Vp-p.
  - D) Gradually adjust sustain to 10. U4/P7 should increase to 1.7Vp-p.
  - E) Disengage compressor and continue.
- 11) Limiter adjustment. Adjust R174 to get a flat response at U21/P2 (compare fig.)
- 12) Set the following: volume on 0; 4 ohm load.
- 13) Slowly turn up volume just until limiter LED begins to light. At this point, output should be at full power =20Vrms.
- 14) Current limiter test. Change to a 2 ohm load. Output should be a clean sine wave without clipping and = 12Vrms (+or-) .5Vrms.
- 15) Turn master up and down to check if it works properly.
- 16) Set the following: volume and master on 10, no load.
- 17) Check direct out (J5) pins 2 and 3 = 550mVrms (1.5Vp-p).
- 18) Check balance out left ( J8) and right (J9). Both should = 5.5Vrms in stereo and mono mode at pins 2 and 3.
- 19) Check send (J7). 1.7Vp-p, clean sine wave. Probe at R229.
- 20) Check headphone jack (J3). Tip = 3.4Vrms / Ring = 3.4Vrms or 13Vp-p clipped.
- 21) Test return.
  - A) Plug input into return (6). (400Hz 50mVrms sine) -26.0 dB. Output = 4Vrms.
  - B) Line out (J10)= 80mVrms.
- 22) Change to square signal at input (400Hz -26.0dB).
- 23) Test tones and filters and compare figures.
- 24) Chorus test.

Note: Trigger is on the channel, the scope probe is on, and connect to D.0 (J5) @ 1V/div. This will make it possible to make measurements without having trigger problems. An external trigger could also be used.

- A) Volume at 9 o'clock
  - B) Master at 10.
  - C) Tones on 5.
  - D) Engage chorus.
  - E) Rate 0/ Depth 0. Deviation = 1.3 sec. / Rate = 1.5 sec.
  - F) Rate 0/ Depth 10. Deviation = 5.0 sec.
  - G) Rate 10/ Depth 10. Rate = .25 sec.
  - H) Disengage chorus.
- 25) Balance out test. Sine input (400Hz 50mVrms) -26.0dB.
- A) Volume on 5.
  - B) Master on 10.
  - C) Tones on 5. Balance out left pins 2 and 3 and balance out right pins should look different. Left should swell up and down to a min. and max. value. Right should do the same, however oscillate right and left.
  - D) Engage chorus.
  - E) Stereo switch out.
  - F) Push in stereo switch (mono mode). Signal on left and right should look similar, swelling up and down.
  - G) Chorus off.
- 26) Check speaker cut-off switch.
- 27) Disconnect input.
- 28) Proceed with noise and tap test.
- A) Controls on 10, switch out = noise <60mVrms.
  - B) Controls on 10, contour in = noise <80mVrms.
  - C) Controls on 10, comp. in, sustain 0 = noise < 50mVrms.
  - D) Controls on 10, comp. in, sustain 10 = noise < 250mVrms.
  - E) Controls on 10, comp. in, sustain 10 = noise < 300mVrms.
  - F) Contour in, chorus in = noise < 40mVrms.
  - G) Contour in, master on 0 = noise < 2.5mVrms.

Noise should be clean without popping or cracking.

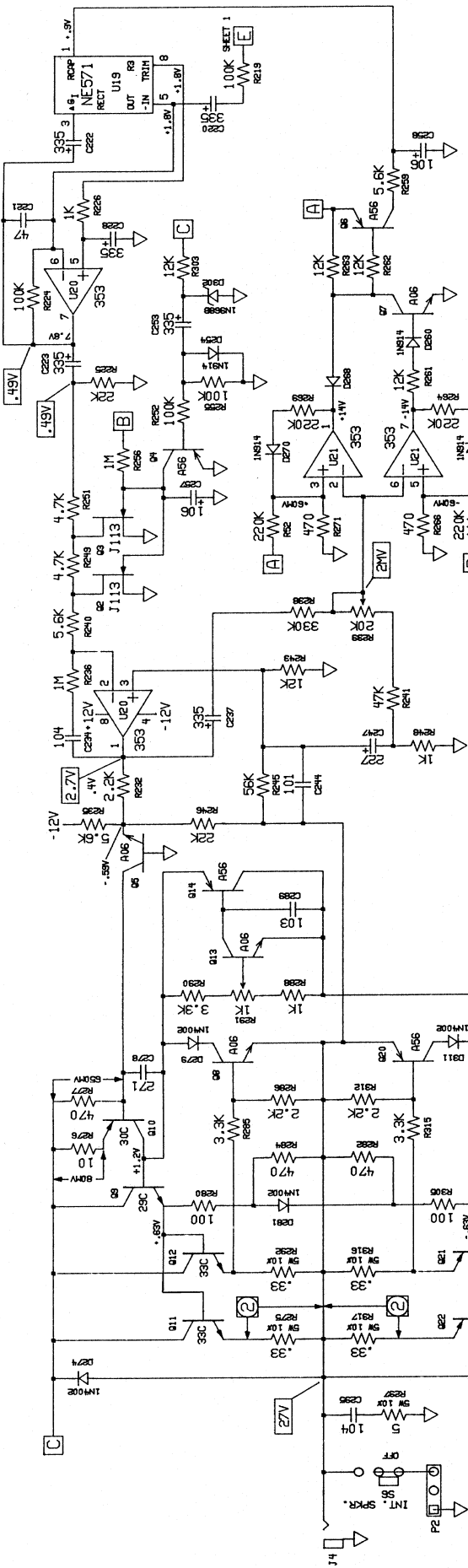

NOTES: UNLESS OTHERWISE SPECIFIED,

1. TEST CONDITIONS: 5MV 400HZ SINE.  
VOLUME, TONES AND MASTER AT 10.  
COMPRESSOR, CONTOUR AND CHORUS OFF.  
NO LOAD AT OUTPUT.
2. ADJUST R291 FOR 5MV BIAS ACROSS R292 AND R316.

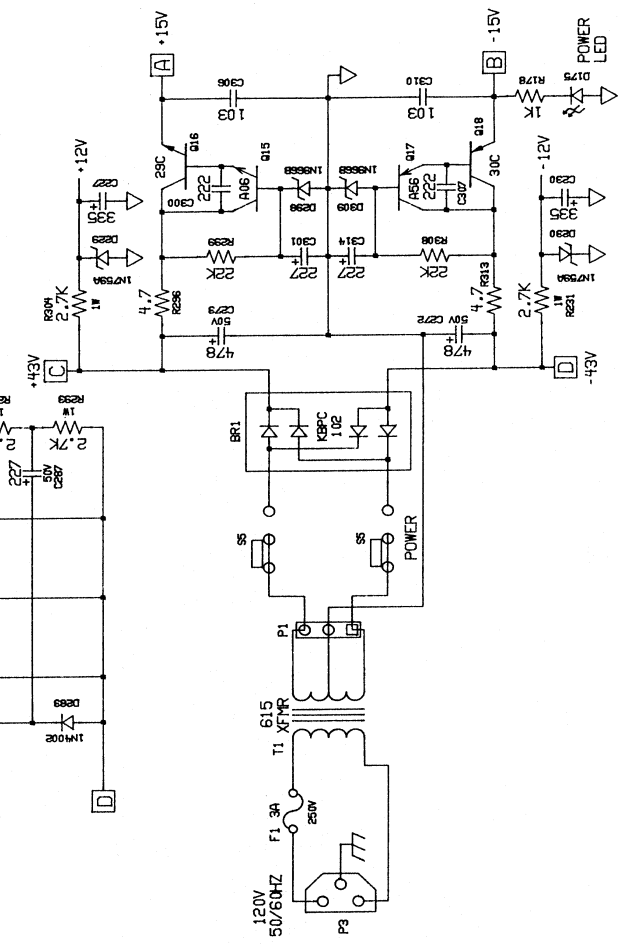

GALLIEN-KRUEGER	MODEL #:	DATE:	DESCRIPTION:
SCHEMATIC PG: 2 OF: 2	200MB/RCB	10-20-89	POWER AMP./ POWER SUPPLY
	DESIGNED BY:	BOARD #:	PCO#-DATE:
		60056F	FROM SN: TO SN:



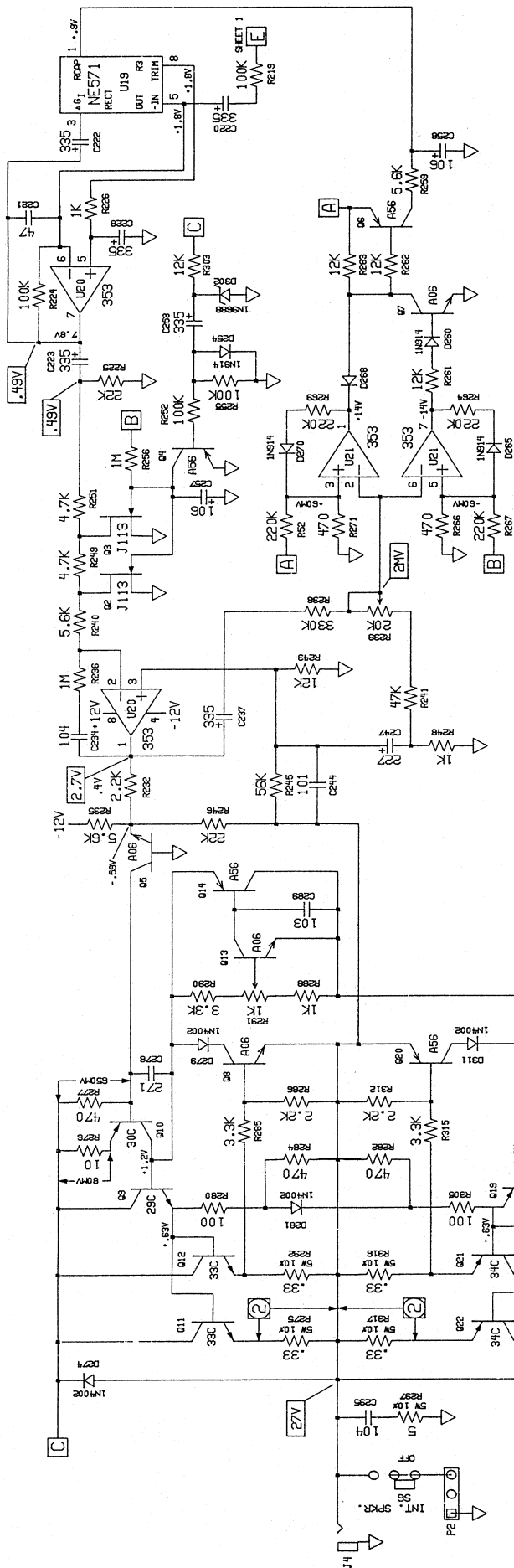

NOTES: UNLESS OTHERWISE SPECIFIED,

- TEST CONDITIONS: 5MV 400HZ SINE.  
VOLUME, TONES AND MASTER AT 10.  
COMPRESSOR, CONTOUR AND CHORUS OFF.  
NO LOAD AT OUTPUT.

ADJUST R291 FOR 5MV BIAS ACROSS R292 AND R316.

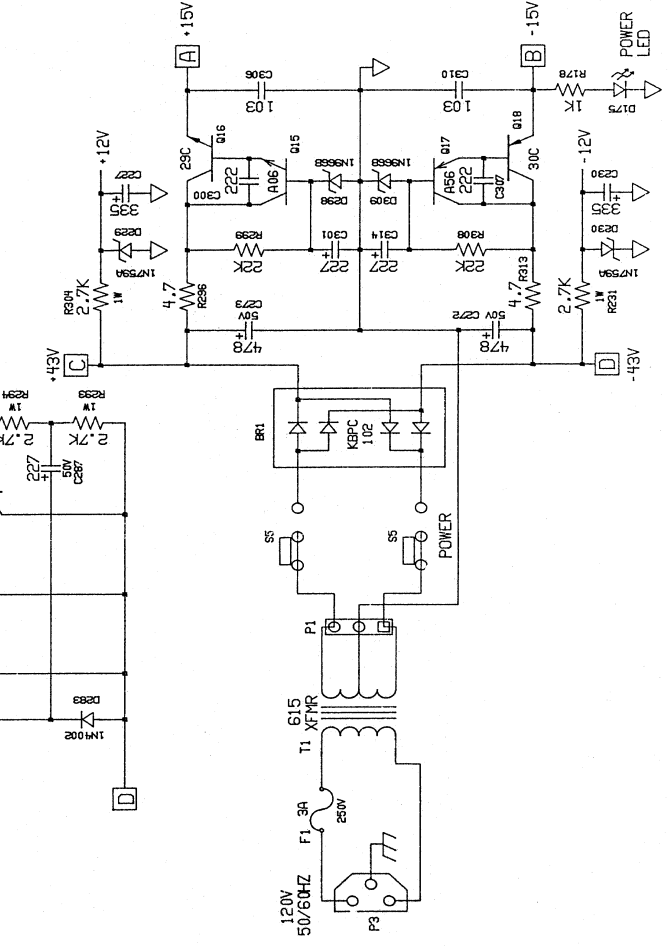

GALLIEN-KRUEGER	MODEL #:	DATE:	DESCRIPTION:
SCHEMATIC PG: 2 OF 2	200MB/RCB	9-8-89	POWER AMP./ POWER SUPPLY
	DESIGNED BY:	BOARD #:	PCO#-DATE:
		600566	FROM SN: TO SN:

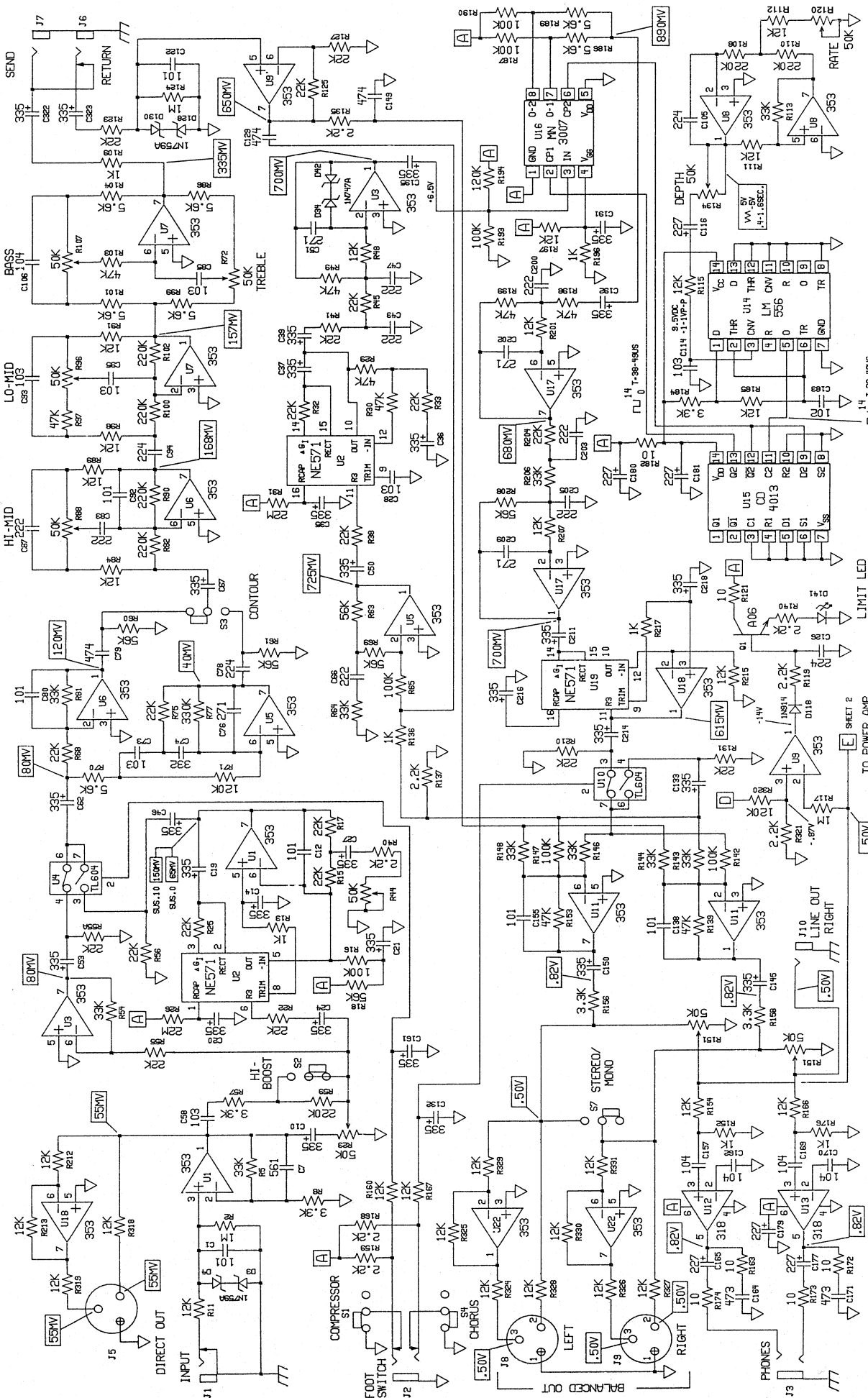

PCO#	DATE	FIRST SN	PCO#	DATE	FIRST SN	PCO#	DATE	FIRST SN	PCO#	DATE	FIRST SN	PCO#	DATE	FIRST SN
GALLIEN-KRUEGER MODEL #: 200MB/RCB DATE: 9-12-89 DESCRIPTION: PREAMP, CHORUS AND REVERB DESIGNED BY: 600566 FROM SN: TO SN:														
SCHEMATIC PG: 1 OF: 2 PCO#: 600566 DATE: 9-12-89 DESCRIPTION: PREAMP, CHORUS AND REVERB DESIGNED BY: 600566 FROM SN: TO SN:														

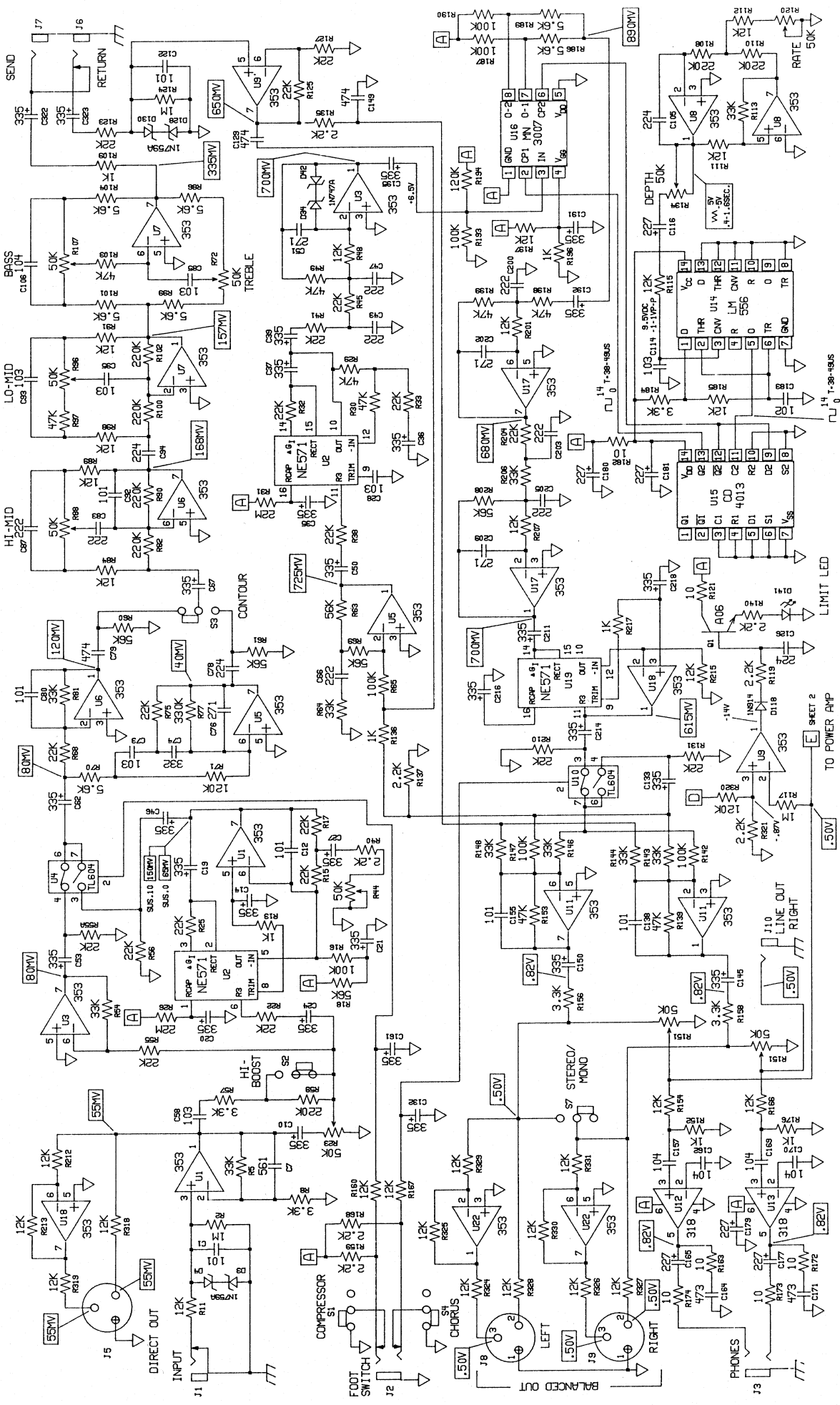

PCO#	DATE	FIRST SN	PCO#	DATE	FIRST SN	PCO#	DATE	FIRST SN	PCO#	DATE	FIRST SN
<b>GALLIEN-KRUEGER</b>											
MODEL #: 200MB/RCB						DATE: 9-12-89					
DESCRIPTION: PREAMP CHORUS AND REVERB						DESIGNED BY: BOARD #: 60056F					
PCO#-DATE: FROM SN: TO SN:						Schematic PG: 1 OF: 2					

200MB CIRCUIT DIAGRAM- REF. DESIG.

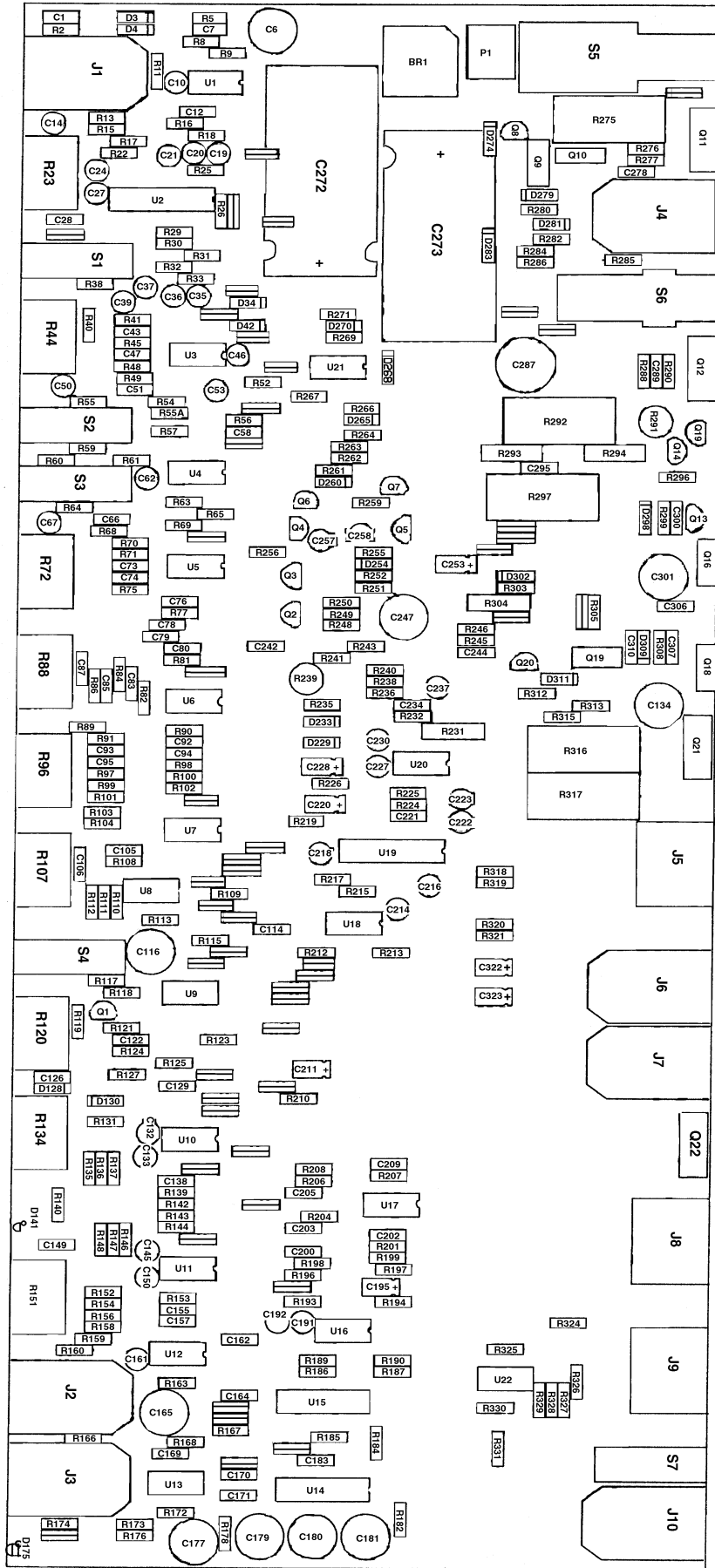

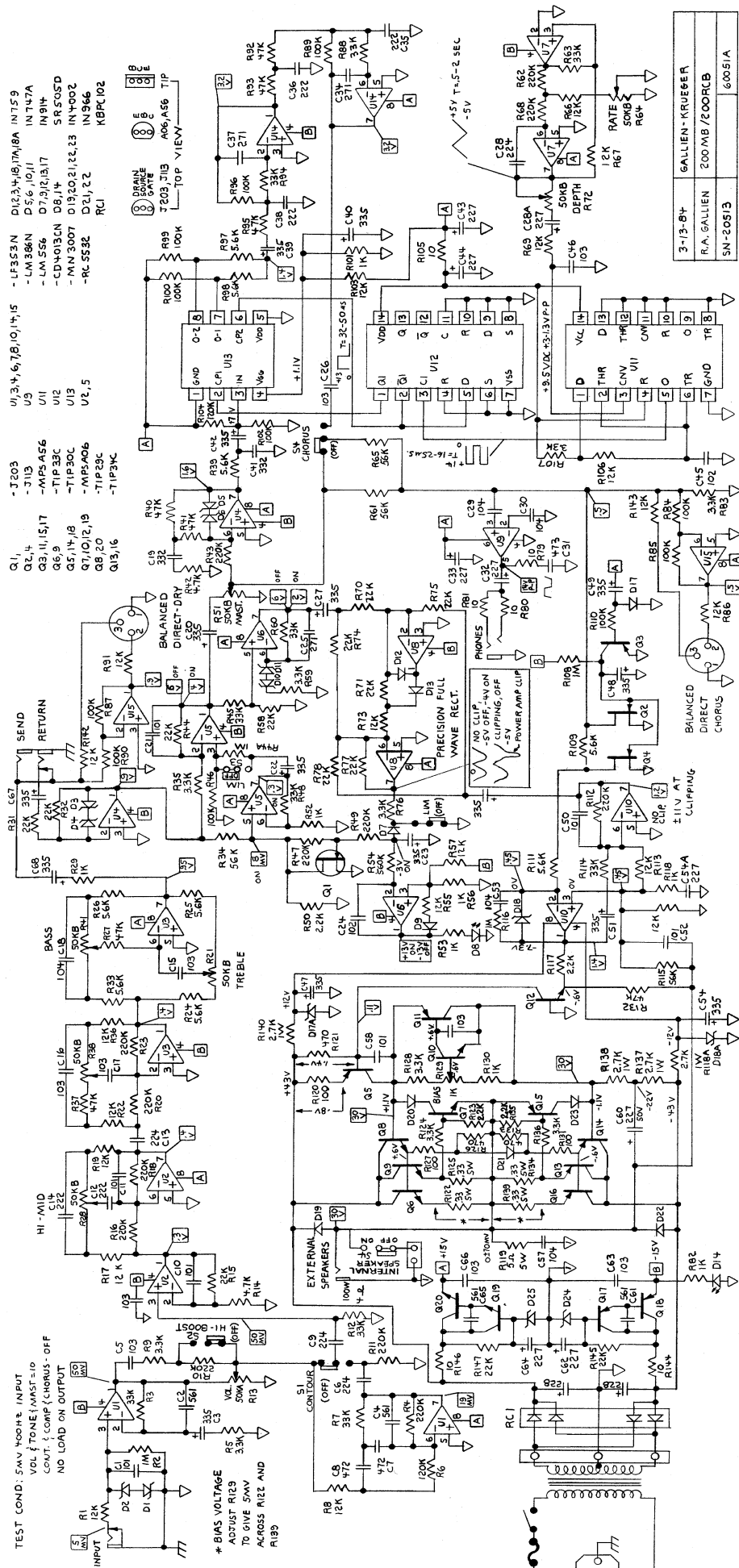

TEST COND. 5MV 400HZ INPUT  
VOL & TONE (MUSIC) 10  
CONT. & CHORUS (CHORUS - OFF  
NO LOAD ON OUTPUT

\*BIAS VOLTAGE  
ADJUST R123  
TO GIVE 5MV  
ACROSS R122 AND  
R129

- U1,3,4,6,7,8,10,14,15 - LF353N
- U9 - LM386N
- U11 - D7,9,12,13,17
- U12 - CD4013CN
- U13 - MN3007
- U2,5 - RC 5532
- Q1,2,4 - 2N303
- Q3,11,15,17 - MPS456
- Q6,9 - TIP30C
- Q5,14,18 - MPA406
- Q7,10,12,19 - 2N303
- Q13,16 - TIP30C
- D1,2,3,4,5,6,7,8,10,11,12,13,14,15,16,17,18,19,20,21,22,23,24,25,26,27,28,29,30,31,32,33,34,35,36,37,38,39,40,41,42,43,44,45,46,47,48,49,50,51,52,53,54,55,56,57,58,59,60,61,62,63,64,65,66,67,68,69,70,71,72,73,74,75,76,77,78,79,80,81,82,83,84,85,86,87,88,89,90,91,92,93,94,95,96,97,98,99,100

3-15-84	GALLIEN-KRUEGER
R.A. GALLIEN	200MB/DOORCB
SN-20513	60051A

\* ADJUST R207 FOR 5-mV BIAS ACROSS R197 AND R224.

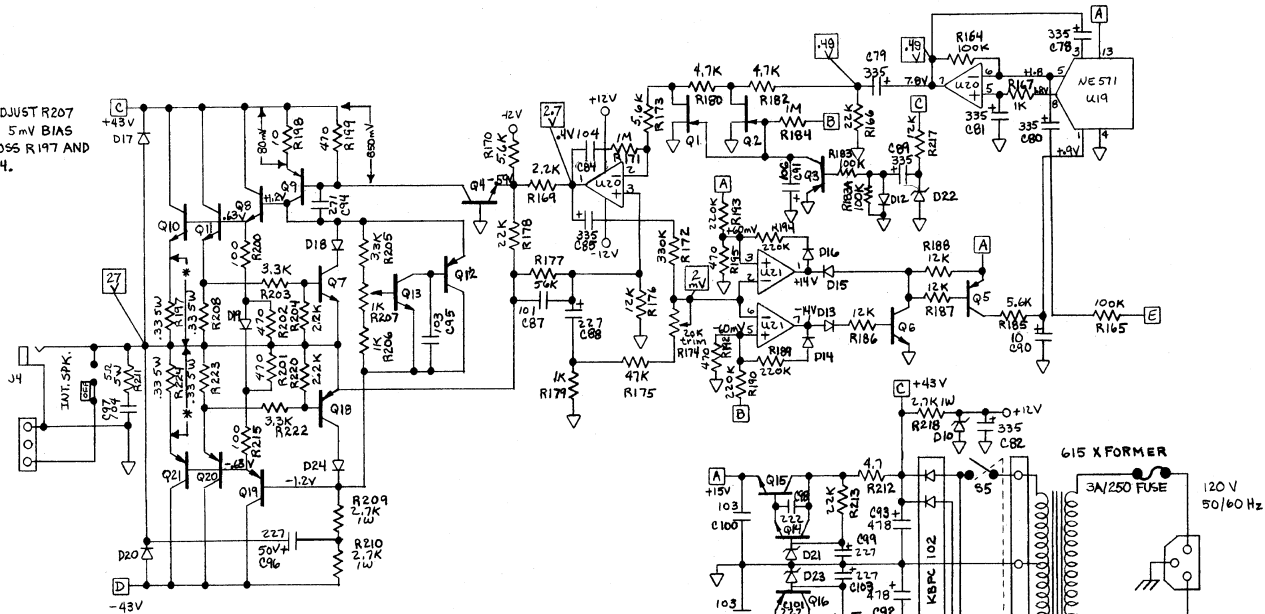

- |                             |             |                   |              |
|-----------------------------|-------------|-------------------|--------------|
| U14                         | - MN3007    | D5,12,13,14,15,16 | - IN94       |
| U14                         | - LM556CN   | D22               | - IN468B     |
| U4,10                       | - TL604CP   | D17,18,19,20,24   | - IN4002     |
| U13,5,6,7,8,9,11,8,20,21,22 | - LF353N    | D3,4              | - IN747A     |
| U15                         | - CD4013BCN | D1,2,6,7,10,11    | - IN759A     |
| U12,13                      | - LM386N    | D21,23            | - IN966B     |
| U2,14                       | - NE571     | D8,9              | - LED-T-1    |
| Q1,2                        | - J113      | J1,6              | - RN112APC   |
| Q3,4,6,7,13,14              | - MPS A06   | J2                | - RN114BPC   |
| Q3,5,12,16,18               | - MPS A56   | J4,7,10           | - RN111PC    |
| Q8,5                        | - TIP29C    | J3                | - RN112BPC   |
| Q9,17,19                    | - TIP30C    | J5,8,9            | - DOX7010ZPC |
| Q10,11                      | - TIP33C    |                   |              |
| Q20,21                      | - TIP34C    |                   |              |

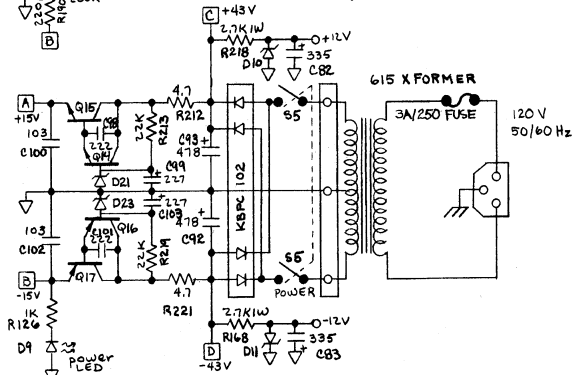

11-4-85	GALLIEN-KRUEGER
M. JOHNS	200MB
	60056B

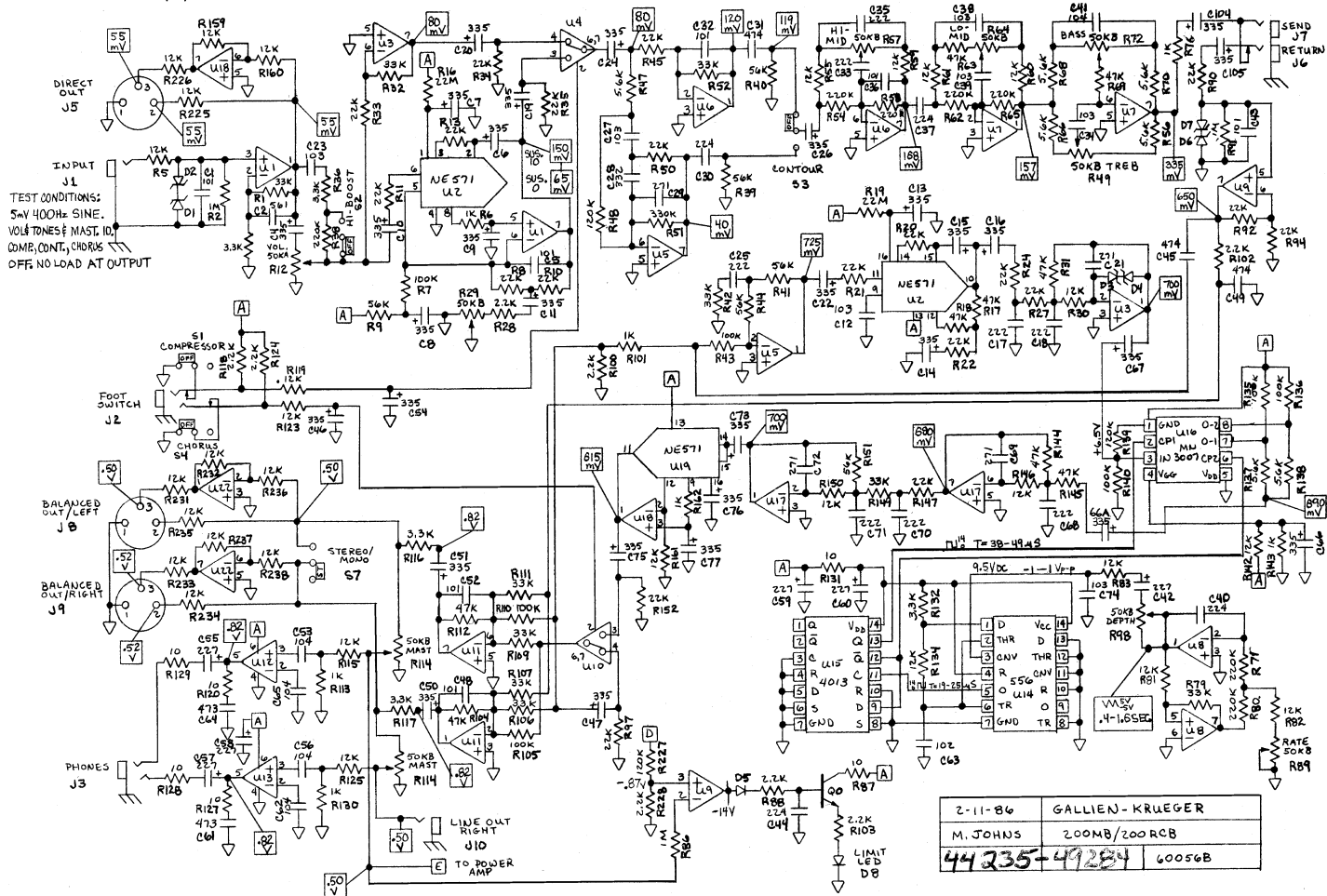

2-11-86	GALLIEN-KRUEGER
M. JOHNS	200MB/200RCB
44235-49284	60056B

\* ADJUST R207 FOR 5mV BIAS ACROSS R197 AND R224.

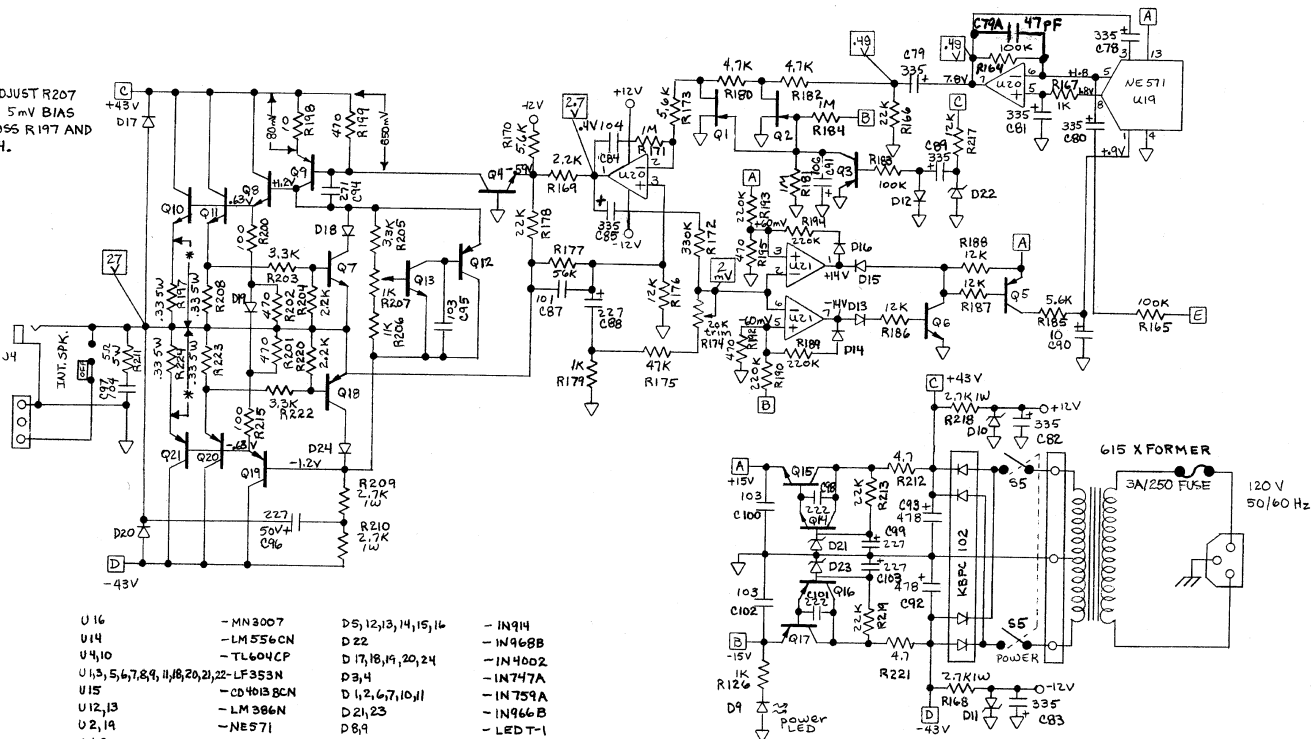

- |   |             |                        |               |
|---|-------------|------------------------|---------------|
| U16                                     | - MN3007    | D5, 12, 13, 14, 15, 14 | - IN914       |
| U14                                     | - LM556CN   | D22                    | - IN968B      |
| U4, 10                                  | - TL604CP   | D17, 18, 19, 20, 24    | - IN4002      |
| U1, 3, 5, 6, 7, 8, 9, 11, 8, 20, 21, 22 | - LF353N    | D3, 4                  | - IN747A      |
| U15                                     | - CD4013BCN | D1, 2, 6, 7, 10, 11    | - IN759A      |
| U12, 13                                 | - LM386N    | D21, 23                | - IN966B      |
| U2, 14                                  | - NE571     | D8, 9                  | - LEDT-1      |
| Q1, 2                                   | - J113      | J1, 6                  | - RN112APC    |
| Q3, 4, 6, 7, 13, 14                     | - MFS A06   | J2                     | - RN114BPC    |
| Q3, 5, 12, 16, 18                       | - MFS A56   | J4, 7, 10              | - RN111PC     |
| Q8, 15                                  | - TIP29C    | J3                     | - RN112BPC    |
| Q9, 17, 19                              | - TIP30C    | J5, 8, 9               | - D.O X7062PC |
| Q10, 11                                 | - TIP33C    |                        |               |
| Q20, 21                                 | - TIP34C    |                        |               |

11-4-85	GALLIEN-KRUEGER
M. JOHNS	ZOOM B
	60056B

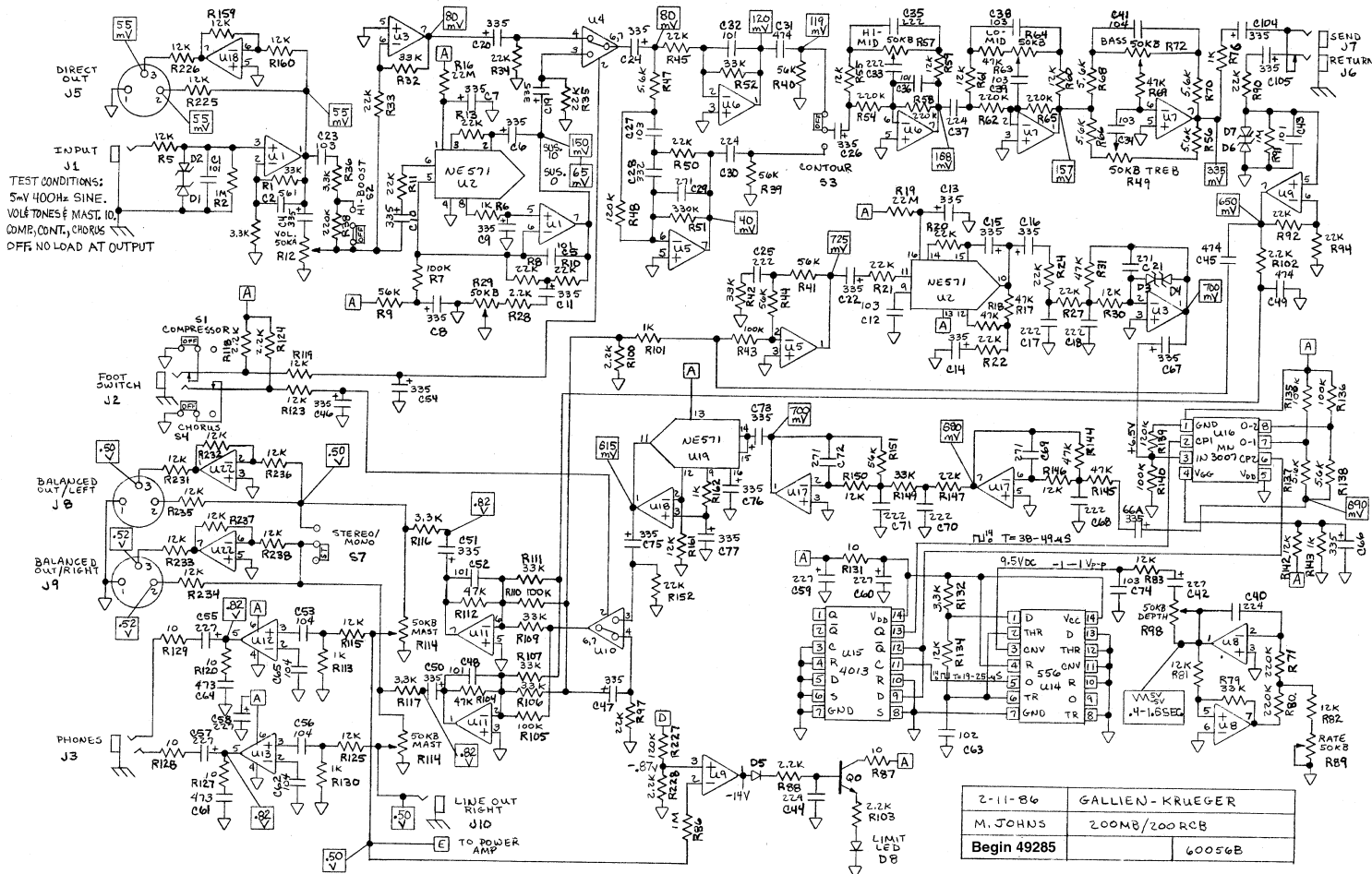

2-11-86	GALLIEN-KRUEGER
M. JOHNS	ZOOM B / ZOOM CB
Begin 49285	60056B

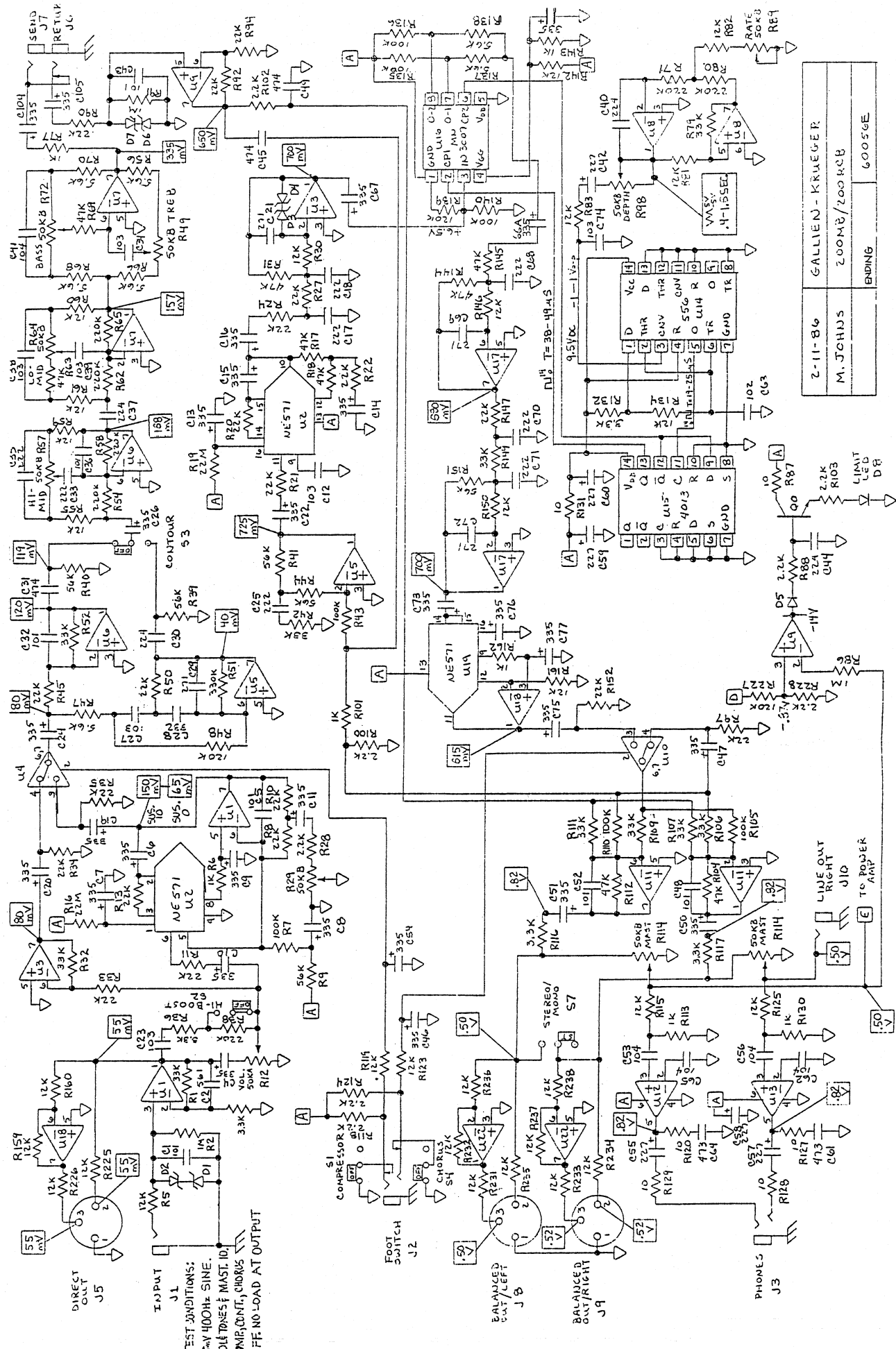

TEST CONDITIONS:  
 5mV 400Hz SINE.  
 W/LE TONES & MAST. ID.  
 COMP. CONT., CHORUS  
 OFF NO LOAD AT OUTPUT

2-11-86	GALLIEN - KRUEGER
M. JOHNS	ZOOMER/200KCB
	BINDING
	60056E



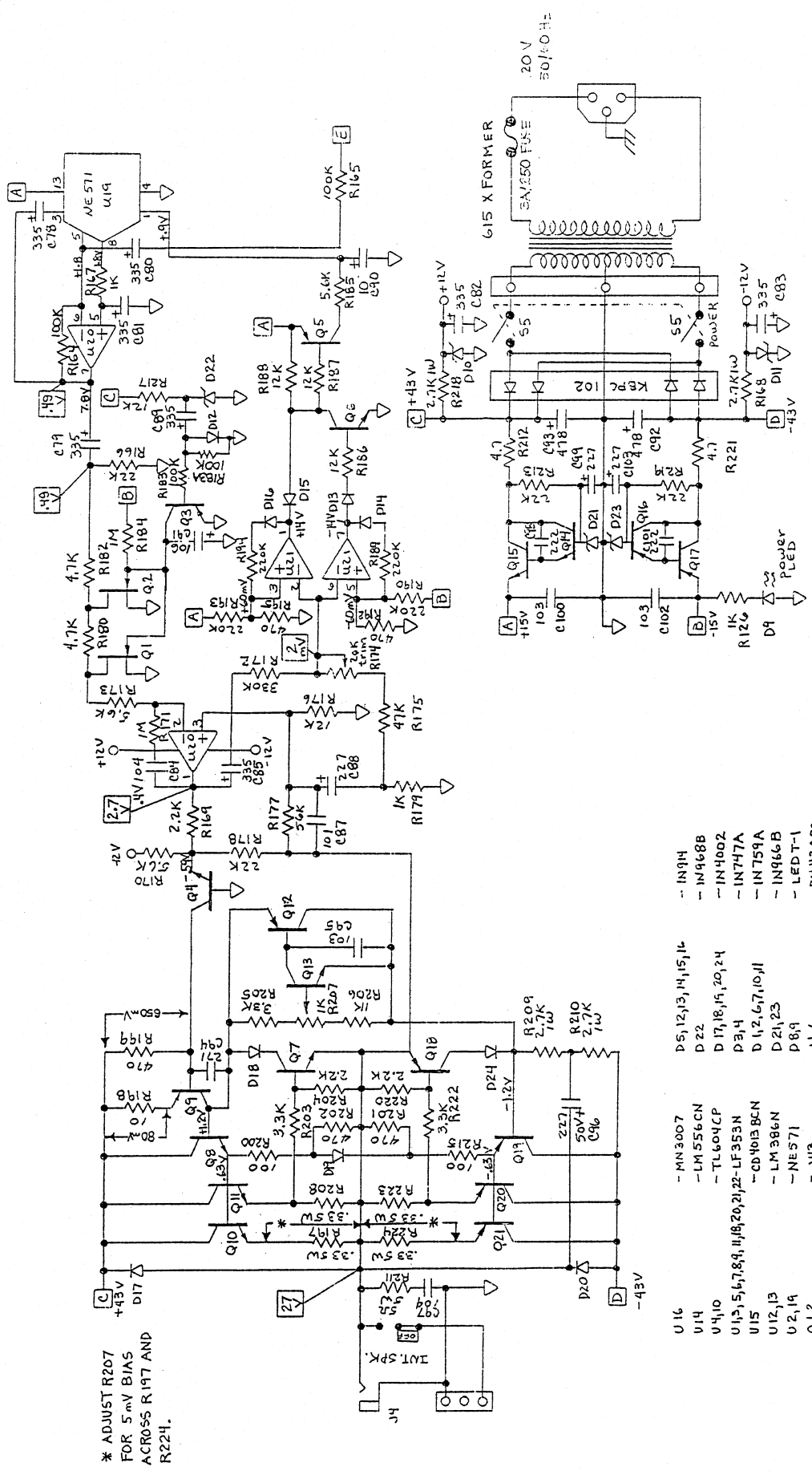

\* ADJUST R207 FOR 5mV BIAS ACR055 R197 AND R221.

- U16 - MN3007
- U14 - LM556CN
- U14,10 - TL604CP
- U13,5,6,7,8,9,11,18,20,21,22 - LF353N
- U15 - CD4013 BCN
- U12,13 - LM386N
- U2,14 - NE571
- Q1,2 - J113
- Q3,4,6,7,15,14 - MPSA06
- Q3,5,12,16,18 - MPSA56
- Q8,15 - TIP29C
- Q9,17,19 - TIP30C
- Q10,11 - TIP35C
- Q20,21 - TIP34C
- D5,12,13,14,15,16 - 1N914
- D22 - 1N968B
- D17,18,19,20,24 - 1N4002
- D3,4 - 1N747A
- D1,2,6,7,10,11 - 1N759A
- D21,23 - 1N966B
- D8,9 - LED-T-1
- J1,6 - RN12ARC
- J2 - RN11HBC
- J4,7,10 - RN111FC
- J3 - RN112BC
- J5,8,9 - D.O.X7D02RC

11-4-85	GALLIEN-KRUEGER
M. JOHNS	200MB
	ENDING: 60056E

GALLIEN-KRUEGER		PRODUCTION CHANGE ORDER		PCO# :			
DATE: <b>8-25-89</b>		ASSEMBLY #: <b>60056G</b>		MODEL#: <b>200MB/RCB</b>			
ASSEMBLY DESCRIPTION:				PAGE <u>1</u> OF <u>1</u>			
AFFECTS OPTIONS: <input checked="" type="checkbox"/> ALL <input type="checkbox"/> 100V <input type="checkbox"/> 120V <input type="checkbox"/> 220V <input type="checkbox"/> 240V <input type="checkbox"/> 50HZ <input type="checkbox"/> 60HZ							
TYPE OF CHANGE: <input checked="" type="checkbox"/> NECESSARY TO THE FUNCTION OF THE UNIT <input type="checkbox"/> IMPROVEMENT OR ADDITION TO THE UNIT <input type="checkbox"/> OTHER _____							
CHANGE TO BE IMPLEMENTED TO: <input checked="" type="checkbox"/> NEXT PRODUCTION RUN <input type="checkbox"/> ALL UNITS IN PRODUCTION <input type="checkbox"/> ALL UNITS IN STOCK <input type="checkbox"/> ALL UNITS BEING SERVICED <input type="checkbox"/> OTHER _____			REMARKS:				
BEGINNING SERIAL NUMBER AFFECTED:							
DESCRIPTION OF CHANGE: <input type="checkbox"/> SEE PCO SUPPLEMENTS <input type="checkbox"/> CONTINUED ON PCO SUPPLEMENT PAGE _____ <b>ENLARGE PAD SIZES.</b>							
REASON FOR CHANGE: <b>PADS ARE NOT LARGE ENOUGH TO HOLD SOLDER, PADS AND TRACES LIFT WHEN DESOLDERED AND RESOLDERED,</b>							
PARTS ADDED				PARTS DELETED			
PART#	DESCRIPTION	QTY.	REF. DES.	PART#	DESCRIPTION	QTY.	REF. DES.
<input type="checkbox"/> CONTINUED ON PAGE _____				<input type="checkbox"/> CONTINUED ON PAGE _____			
AFFECTED AREAS	DONE BY	DATE	AFFECTED AREAS	DONE BY	DATE		
<input type="checkbox"/> BLOCK DIAGRAM			<input type="checkbox"/> DELETED PART REPORT				
<input type="checkbox"/> CIRCUIT SCHEMATIC			<input checked="" type="checkbox"/> FAB DRAWING	<b>M'</b>	<b>8-18-89</b>		
<input checked="" type="checkbox"/> BOARD ARTWORK	<b>M'</b>	<b>8-31-89</b>	<input type="checkbox"/> PUNCH PROGRAM				
<input type="checkbox"/> REF. DES. SLKSCRN.			<input type="checkbox"/> PUNCH SAMPLE				
<input type="checkbox"/> COMPONENT DRIVING.			<input type="checkbox"/> ASSEMBLY PROCEDURES				
<input type="checkbox"/> DRILL DRAWING			<input type="checkbox"/> FRONT PANEL ARTWK.				
<input type="checkbox"/> SOLDER MASK			<input type="checkbox"/> REAR PANEL ARTWK.				
<input type="checkbox"/> BILL OF MATERIAL			<input type="checkbox"/> TOOLING CHANGE				
<input type="checkbox"/> PULL SHEET			<input type="checkbox"/> TEMPLATE CHANGE				
<input type="checkbox"/> AUTO INSERTER			<input type="checkbox"/> OUTSIDE SUPPLIERS				
<input type="checkbox"/> SAMPLE CHANGE			<input type="checkbox"/> NEW PROCESS				
<input type="checkbox"/> TEST PROCEDURE			<input type="checkbox"/>				
<input type="checkbox"/> SPECIFICATIONS			<input type="checkbox"/>				
DRAWING(S) SHOWING MODIFICATION ATTACHED: <input type="checkbox"/> NO <input type="checkbox"/> YES-SPECIFY:							
WRITTEN BY: <b>M.E. ITURRALDE</b>		DEPT: <b>ENG'R SERVICES</b>		DATE: <b>9-7-89</b>			
REVIEWED/APPROVED BY:		DEPT:		DATE:			
COPIES TO: <input type="checkbox"/> PROJ LDR <input type="checkbox"/> ENG <input type="checkbox"/> PROD <input type="checkbox"/> FAB <input type="checkbox"/> PURCH <input type="checkbox"/> CAD <input type="checkbox"/> _____ <input type="checkbox"/> _____							

**200MB INDENTED BILL OF MATERIALS****NOTE:**

Level 1 refers to main assembly parts.

Level 2 refers to board level components.

Main assembly numbers are in bold face, while commonly needed parts are italicized.

<b>LVL</b>	<b>PART#</b>	<b>DESCRIPTION</b>	<b>QTY</b>	<b>REF. DESIG.</b>
1	010-0012-0	MPSA06 NPN 80V 500MA TO-92	1	
1	011-0023-0	TIP29C NPN 100V 1A TO-220 FP	1	
1	011-1035-0	TIP30C PNP 100V 1A TO-220	1	
1	012-0084-0	TIP 33CFP NPN 100V 10A TO218	2	
1	012-1085-0	TIP 34CFP,PNP,100V,10A,TO-218,PECOR	2	
1	025-0116-0	RED LED,1.5MCD,120 DEG,T-1	2	
1	<i>080-0061-0</i>	<i>TRANSFORMER,100W,120V</i>	1	
1	082-0039-0	SPEAKER,12",80W,Z=8,PYLE FOAM EDGE	1	
1	<i>091-0003-0</i>	<i>FUSE, 3A,125V,1/4X1 1/4,SLB</i>	1	
2	799-TEST-0	TRY OUT	0	
1	092-0009-0	XLR,MALE,PC TERM TRIANGLE	3	
1	<i>093-0014-0</i>	<i>RECEPTICAL AC,Q-TERM</i>	1	
1	093-0032-0	HOUSING,3X.156,FEMALE 22GA,LOCK	2	
1	<i>094-0013-0</i>	<i>HOLDER,FUSE,1/4 X 1 1/4,Q-TERM</i>	1	
1	094-0019-0	SOLDER LUG,#6	1	
1	<i>095-0005-0</i>	<i>POWER CORD,117V PLUG,DETACH</i>	1	
1	100-0012-0	GROMIT,3/16 X.100	1	
1	100-0016-0	LOGO,3 INCH,CAST	1	
1	100-0027-0	BUTTON,ROUND BLACK CAP - PUSH SWITCH	1	
1	100-0030-0	BUTTON,RECT BLACK CAP - PUSH SWITCH	1	
1	100-0037-0	HEAT CLIP,TO-98	1	
1	<i>100-0042-0</i>	<i>HANDLE,RUBBER,6.5"</i>	1	
1	100-0044-0	BUMPER,1/2",SQUARE	2	
1	<i>100-0057-0</i>	<i>KNOB BODY 18 SPLINE SHAFT</i>	9	
1	<i>100-0062-0</i>	<i>KNOB CAP GRAY,FOR 100-0057</i>	9	
1	<i>100-0065-0</i>	<i>CAP FOR 6.5" HANDLE "BLACK"</i>	2	
1	100-0076-0	FOOT,RUBBER,ROUND,5/8DIA. X 5/8"	4	
1	111-0061-0	BOLT 4-40 3/8 PHP CAD	4	
1	111-0081-0	BOLT 4-40 1/2 PHP CAD	6	
1	111-3041-0	SCREW 4AB 1/4 PHP CAD	6	

LVL	PART#	DESCRIPTION	QTY	REF. DESIG.
1	111-6001-0	NUT 4-40 KEP SMALL	4	
1	111-6011-0	NUT 4-40 HEX SMALL CAD	6	
1	111-7011-0	WASHER #4 SPLIT	6	
1	112-0051-0	BOLT 6-32 5/16 PHP CAD	4	
1	112-1050-0	BOLT 6-32 5/16 FHP 82^ B.O.	11	
1	112-1120-0	BOLT 6-32 3/4 FHP 82^ B.O.	8	
1	112-4080-0	SCREW 6AB 1/2 FHP 82^ B.O.	38	
1	112-4081-0	SCREW 6AB 1/2 FHP 82^ CAD	1	
1	112-4140-0	SCREW 6AB 7/8 FHP 82^ B.O.	1	
1	112-6001-0	NUT 6-32 KEP LARG SIZE CAD	8	
1	112-7001-0	WASHER #6 FLAT CAD	12	
1	113-0080-0	BOLT 8-32 1/2 PHP B.O.	4	
1	113-6011-0	NUT 8-32 KEP CAD	4	
1	114-0080-0	BOLT 10-32 1/2 PHP B.O.	2	
1	115-7005-0	WASHER 3/8 FIBRE FLAT	1	
1	115-7021-0	WASHER 3/8 INTERNAL CAD	12	
1	115-7031-0	WASHER SMALL 3/8 LOCK CAD	3	
1	132-0349-A	200MK/MV TOP COVER	1	
2	120-0005-0	ALUM .100	98	
1	132-0350-B	200MB-MK RIGHT SIDE	1	
2	114-6046-0	NUT 10-32 CAPTIVE	1	
2	120-0005-0	ALUM .100	164	
1	132-0351-B	200MB-MK LEFT SIDE	1	
2	114-6046-0	NUT 10-32 CAPTIVE	1	
2	120-0005-0	ALUM .100	164	
1	132-0352-B	200MB BAFFLE	1	
2	120-0005-0	ALUM .100	384	
1	132-0356-B	200MK GRILL	1	
2	120-0003-0	STEEL,16GA,PERF,3'X10'X.060	0	
2	120-0011-0	STEEL,18 GAUGE JET COAT,.048	272	
1	132-0384-B	200MB FRONT PANEL SERIES 2	1	
2	112-6016-0	NUT 6-32 CAPTIVE	5	
2	120-0007-0	ALUM .063	54	

LVL	PART#	DESCRIPTION	QTY	REF. DESIG.
1	132-0385-B	200MB REAR PANEL SERIES 2	1	
2	112-6016-0	NUT 6-32 CAPTIVE	10	
2	120-0005-0	ALUM .100	45	
1	132-0386-D	200MB BACK SERIES 2	1	
2	120-0005-0	ALUM .100	406	
1	160-0008-0	MANUAL,MB-RCB SERIES II	1	
1	202-0014-0	200MB WIRE KIT	1	
<b>1</b>	<b>206-0056-G</b>	<b>200MB-RCB II AMP</b>	<b>1</b>	
2	001-0006-0	MN3007 1024 STAGE BBD	1	
2	001-1030-0	LF353N DUAL JFET OP AMP	13	U1,3,5,6,7,8,9,11,17,18,20,21,22
2	001-1038-0	LM386 LOW VOLTAGE POWER AMP	2	U12,13
2	001-2009-0	LM556CN DUAL TIMER	1	U14
2	001-3028-0	TL604 DUAL COMP ANALOG SWITCH	2	U4,10
2	001-4043-0	NE571 DUAL COMPANDOR	2	
2	002-0034-0	CD4013 DUAL D FLIP-FLOP	1	U15
2	010-0012-0	MPSA06 NPN 80V 500MA TO-92	5	Q0,4,6,7,14
2	010-1013-0	MPSA56 PNP 80V 500MA TO-92	5	Q3,5,12,16,18
2	010-2010-0	J113 N-JFET 35V 2MA TO-92	2	Q1,2
2	011-0023-0	TIP29C NPN 100V 1A TO-220 FP	1	Q8
2	011-1035-0	TIP30C PNP 100V 1A TO-220	2	Q9,18
2	020-0036-0	1N747A,ZENER,3.6V,5%,400MW,DO-35	2	D3,4
2	020-0120-0	1N759A,ZENER,12V,5%,400MW,DO-35	6	D1,2,6,7,10,11
2	020-0160-0	1N966B,ZENER,16V,5%,400MW,DO-35	2	D21,23
2	020-1103-0	1N914 ,RECT-FAST,200MA,100V,4NS,DO-35	6	D5,12,13,14,15,16
2	020-2105-0	1N4002,RECT,1A,150V,DO-41	5	D17,18,19,20,24
2	023-0109-0	KBPC-102 BRIDGE RECT 3A,200V,C219K	1	BRIDGE RECTIFIER
2	030-1103-0	CAP,CERAMIC AXIAL,103,30%,25V	11	C12,23,27,34,38,39,74,86,95,100,102
2	030-2101-0	CAP,CERAMIC AXIAL,101,5%,50V	8	C1,5,32,36,43,48,52,87
2	030-2102-0	CAP,CERAMIC AXIAL,102,10%,50V	1	C63
2	030-2104-0	CAP,CERAMIC AXIAL,104,10%,50V,XR7,.3"	7	
2	030-2222-0	CAP,CERAMIC AXIAL,222,10%,50V	10	C17,18,25,33,35,68,70,71,98,101
2	030-2224-0	CAP,CERAMIC AXIAL,224,20%,50V,XR7	4	C30,37,40,44
2	030-2271-0	CAP,CERAMIC AXIAL,271,10%,50V	5	C21,29,69,72,94

LVL	PART#	DESCRIPTION	QTY	REF. DESIG.
2	030-2332-0	CAP,CERAMIC AXIAL,332,10%,50V	1	C28
2	030-2470-0	CAP,CERAMIC AXIAL,47,5%,50V	1	C79A
2	030-2473-0	CAP,CERAMIC AXIAL XR7,473,10%,50V	2	C61,64
2	030-2474-0	CAP,CERAMIC AXIAL Z5U,474,20%,50V	3	C31,45,49
2	030-2561-0	CAP,CERAMIC AXIAL,561,10%,50V	1	C2
2	031-1227-0	CAP,ELECTROLYTIC RADIAL,227,-10%+50%,25V	10	C3,42,55,57,58,59,60,88,99,103
2	031-2106-0	CAP,ELECTROLYTIC RADIAL,106,-10%+50%,50V	2	C90,91
2	031-2227-0	CAP,ELECTROLYTIC RADIAL,227,-10%+50%,50V	1	C96
2	031-2335-0	CAP,ELECTROLYTIC RADIAL,335,20%,50V	32	C4,6,7,8,9,10,11,13,14,15,16,19,20,22,24,26,46,47,50,51,54,66,67,73,75,76,77,78,79,80,81,82,83,85,89,91,104,105,66A
2	038-2335-0	CAP,ELECTROLITIC AXIAL TR 335,20% 25V	7	
2	038-2478-0	CAP,ELECTROLYTIC AXIAL,478,20%,50V	2	C92,93
2	051-0100-0	RES,CARBON FILM,1 OHM,1/4W,5%	40	R4,14,15,23,25,26,37,46,53,67,73,74,75,77,78,84,85,93,95,96,99,108,121,122,133,141,148,153,154,155,156,157,158,163,191,196,214,216,229,230
2	051-0101-0	RES,CARBON FILM,10 OHM,1/4W,5%	7	R87,120,127,128,129,131,198
2	051-0470-0	RES,CARBON FILM, 4.7 OHM,1/4W,5%	2	R212,221
2	051-1001-0	RES,CARBON FILM,100 OHM,1/4W,5%	2	R200,215
2	051-1002-0	RES,CARBON FILM,1K OHM,1/4W,5%	11	R6,76,101,113,126,130,143,162,167,179,206
2	051-1004-0	RES,CARBON FILM,100K OHM,1/4W,5%	11	R7,43,105,110,135,136,140,164,165,183,183A
2	051-1005-0	RES,CARBON FILM,1M OHM,1/4W,5%	5	R2,86,91,171,184
2	051-1203-0	RES,CARBON FILM,12K OHM,1/4W,5%	23	R5,30,55,59,60,61,81,82,83,115,119,123,125,134,142,146,150,161
2	051-1204-0	RES,CARBON FILM,120K OHM,1/4W,5%	3	R48,139,227
2	051-2202-0	RES,CARBON FILM,2.2K OHM,1/4W,5%	11	R28,88,100,102,103,118,124,169,204,220,228
2	051-2203-0	RES,CARBON FILM,22K OHM,1/4W,5%	24	R8,10,11,13,20,21,22,24,27,33,34,35,45,50,90,92,94,97,147,152,166,178,213,219
2	051-2204-0	RES,CARBON FILM,220K OHM,1/4W,5%	11	R38,54,58,62,65,71,80,189,190,193,194
2	051-2206-0	RES,CARBON FILM,22M OHM,1/4W,5%	2	R16,19
0.2	051-3302-0	RES,CARBON FILM,3.3K OHM,1/4W,5%	8	R3,36,116,117,132,203,205,222
0.2	051-3303-0	RES,CARBON FILM,33K OHM,1/4W,5%	10	R1,32,42,52,79,106,107,109,111,149
2	051-3304-0	RES,CARBON FILM,330K OHM,1/4W,5%	2	R51,172
2	051-4701-0	RES,CARBON FILM,470 OHM,1/4W,5%	5	R192,195,199,201,202
2	051-4702-0	RES,CARBON FILM,4.7K OHM,1/4W,5%	2	R180,182
2	051-4703-0	RES,CARBON FILM,47K OHM,1/4W,5%	10	R17,18,31,63,69,104,112,144,145,175

LVL	PART#	DESCRIPTION	QTY	REF. DESIG.
2	051-5602-0	RES,CARBON FILM,5.6K OHM,1/4W,5%	10	R47,56,66,68,70,137,138,170,173,185
2	051-5603-0	RES,CARBON FILM,56K OHM,1/4W,5%	7	R9,39,40,41,44,151,177
2	052-0000-0	RES,METAL WIRE, 0 OHM,1/4W,1%	5	
2	052-1213-0	RES,METAL FILM,12.1K OHM,1/4W,1%	12	R159,160,225,226,231,232,233,234,235,236,237,238
2	054-2702-0	RES,CARBON FILM,2.7K OHM,1W,5%	4	R168,209,210,218
2	056-.330-0	RES,CERAMIC WW,.33 OHM,5W,10%	4	R197,208,223,224
2	056-0500-0	RES,CERAMIC WW,5 OHM,5W,10%	1	R211
2	070-0501-0	POT,2X50KB,9MM,PLAST KNURL 14MM,.05W	1	R114
2	070-0506-0	POT,50KA,9MM,PLASTIC KNURL 14MM,.05W	1	R12-volume
2	070-0508-0	POT,1K TRIM,6MM,SLOT,.3W	1	R207
2	070-0509-0	POT,20K TRIM,6MM,SLOT,.3W	1	R174
2	070-0514-0	POT,50KB,LINEAR,9MM,METAL KNURL 9MM,.1	7	R72,88,96,107,120,134,151-all other pots
2	090-0010-0	SWITCH,PP,DPDT,6A,PC TERM	1	S5
2	090-0012-0	SWITCH,MINI PP,DPDT,.1A BRK/MAKE,PC TER	5	S1,2,3,4,7
2	090-0013-0	SWITCH,PP,DPDT,.2A,PC MOUNT	1	S6
2	092-0201-0	JACK SW-RN112APC,1/4",S-TIP,SLDR TERM	2	J1,6-input
2	092-0202-0	JACK SW-RN114BPC,1/4",S-TIP,S-RING,P.C.	1	J2
2	092-0203-0	JACK SW-RN111PC,1/4",O-TIP,P.C. TERM	3	J4,7,10
2	092-0204-0	JACK SW-RN112BPC,1/4",O-TIP,O-RING,P.C.	1	J3
2	093-0028-0	HEADER,3X.156,MALE,LOCK	2	FOR POWER AND SPEAKER CUT-OFF
2	100-0028-0	BUTTON,SQUARE BLACK CAP - MINI SWITCH	5	
2	145-0056-G	200MB BOARD	1	P.C.B.
1	602-0007-0	FORMS,WARRANTY CARDS	1	