

# SERVICE MANUAL

## Schematic Diagrams



CODE : 270209



## Index & Warnings

	<u>RPT114</u>	
	Opening Instructions	2
	Autotest Chart	3
	Blocks Diagram	4
	Power Amplifier & Supply Board, Phones & MIDI I/O Board	5
	Keyboard Interface Board, Contacts Board	6
	CPU & Sound Generator Board	7
	<u>RPT114/O (Optical Sensor Version with)</u>	
	Blocks Diagram	4
	Keyboard Interface Board, Optical Contacts Board (Left Part)	8
	Optical Contacts Board (Central & Right Part)	9
	Spare Parts List	10



### Notice

Service must be carried out by qualified personnel only. Any tampering carried out by unqualified personnel during the guarantee period will forfeit the right to guarantee.  
 For a correct operation of the instrument, after having switched off, be careful to wait at least 3 seconds before switching on again.  
 To improve the device's specifications, the schematic diagrams may be subject to change without prior notice.

### Schematic Notes

All components marked by this symbol have special safety characteristics, when replacing any of these components use only manufacturer's specified parts.  
 The (μ) micro symbol of capacitance value is substituted by U. The (Ω) omega symbol of resistance value is substituted by E.  
 The electrolytic capacitors are 25Vdc rated voltage unless otherwise specified. All resistors are 1/4W unless otherwise specified.  
 All switches shown in the "OFF" position. All DC voltages measured to ground with a voltmeter 20KOhm/V.

- |   |                         |
|---|-------------------------|
| ← Soldering point.  | ↑ Supply voltage.       |
| • Male connector.   | ⊥ Logic supply ground.  |
| ⊃ Female connector.   | ⊕ Analog supply ground. |
| ⊓ M/F faston connector.   | ⊖ Signal ground.        |
| ⊠ Test point.   | ⊚ Chassis ground.       |
| ⊔ Flag joined with one or more flags with the same signal name inscribed. |                         |



**ATTENTION**  
 Observe precautions when handling electrostatic sensitive devices

1) To remove the rear panel unscrew the twenty screws from behind of the instrument, pull the cover upwards and lift it up

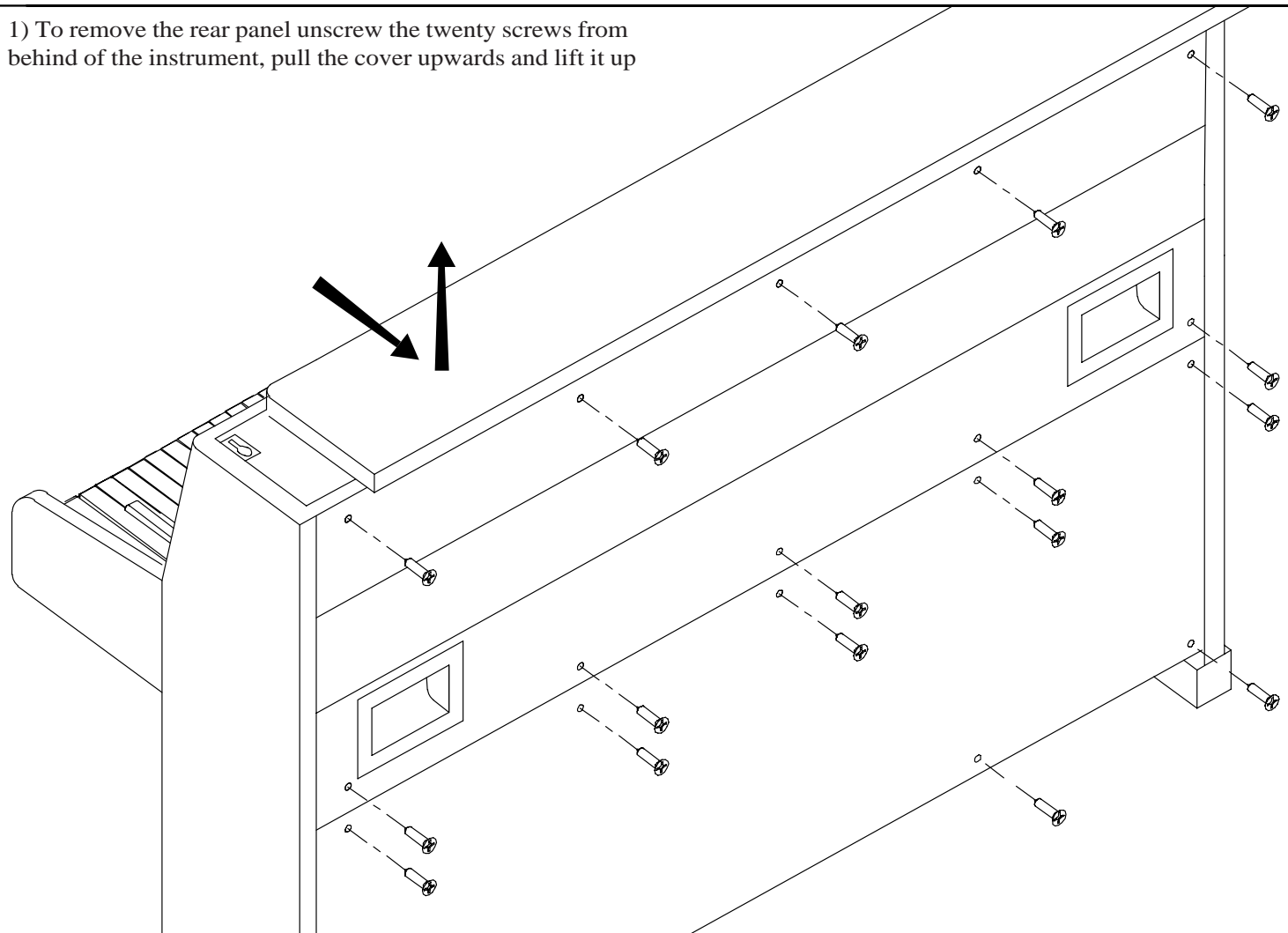

2) To access the electronics parts turn the front panel locks and pull the panel towards you, to remove the control panel unscrew the four screws from the bottom side.

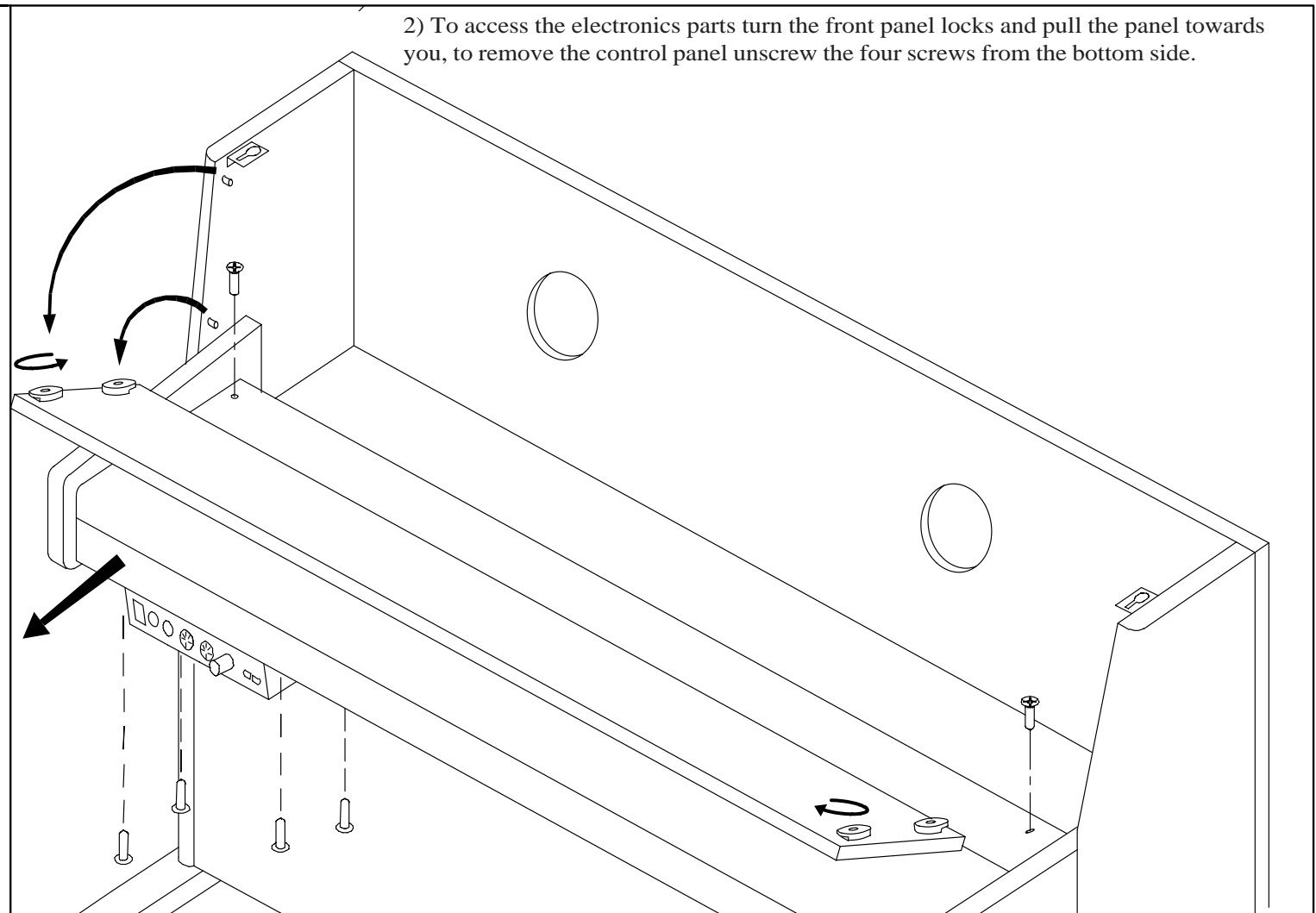

3) To access the speaker box you must unscrew and pull the speakers front panel towards you.

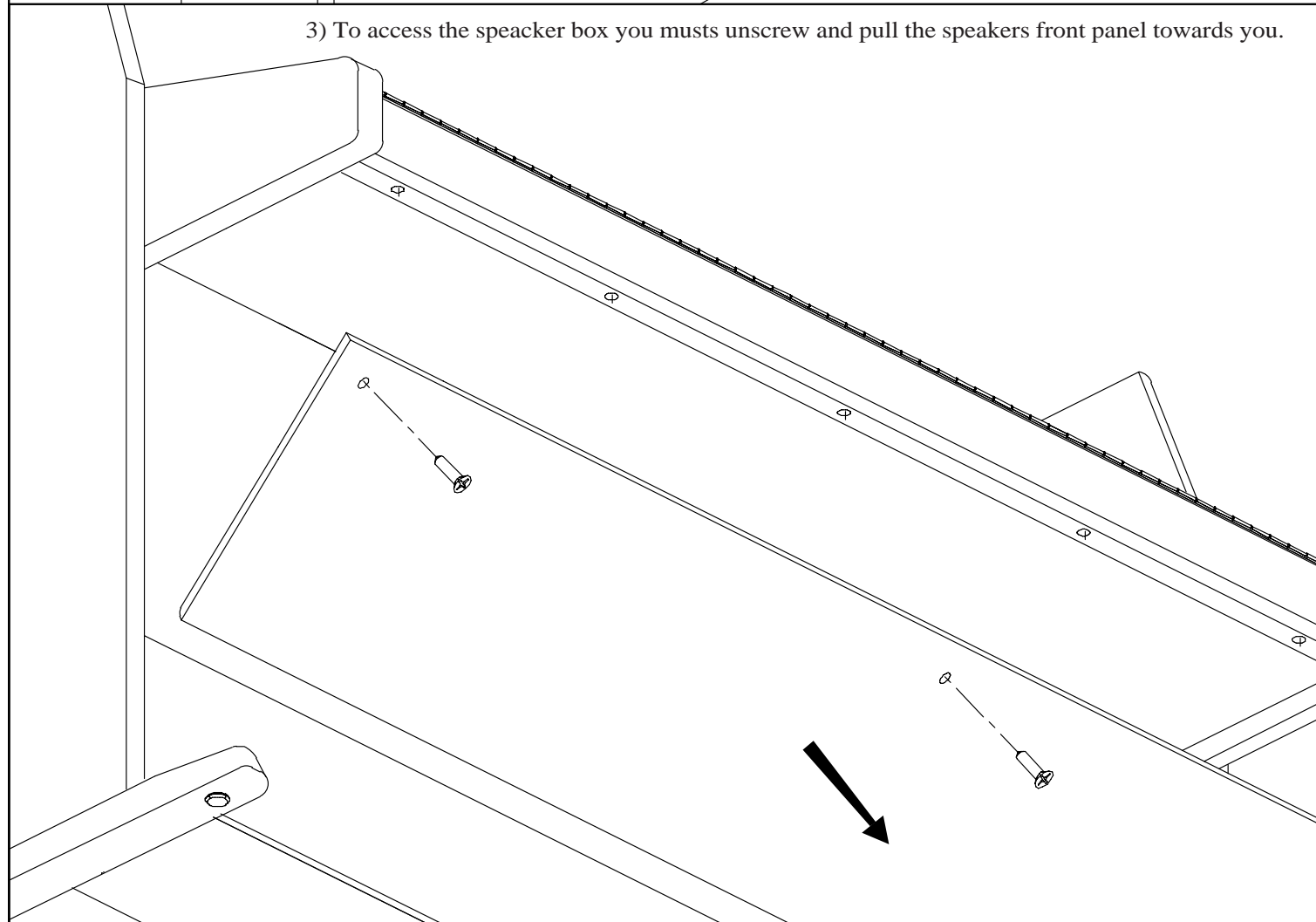

**Assembled Parts (RPT114 version)**

1) Key front	19) Hammer "Load"
2) Key top	20) Hammer stop rail
3) Natural, white key	21) Hammer stop rail felt
4) Sharp, black key	22) Hammer center pin
5) Balance rail pin	23) Hammer but spring
6) Bridle wire, tape wire	24) Hammer flange
7) Jack spring	25) Spoon
8) Regulating button	26) Wippen flange
9) Back check wire	27) Jack
10) Regulating rail felt	28) Jack flange
11) Regulating rail	29) Balance rail pin
12) Bridle strap, bridle tape	30) Front rail punching, front washer
13) Back check	31) Front rail pin
14) Back check felt	32) Contacts Rubber Strip
15) Butt heel leather, back stop leather	
16) Butt heel, catcher, back stop	
17) Hammer rest rail	
18) Hammer rest felt, hammer rest baize	

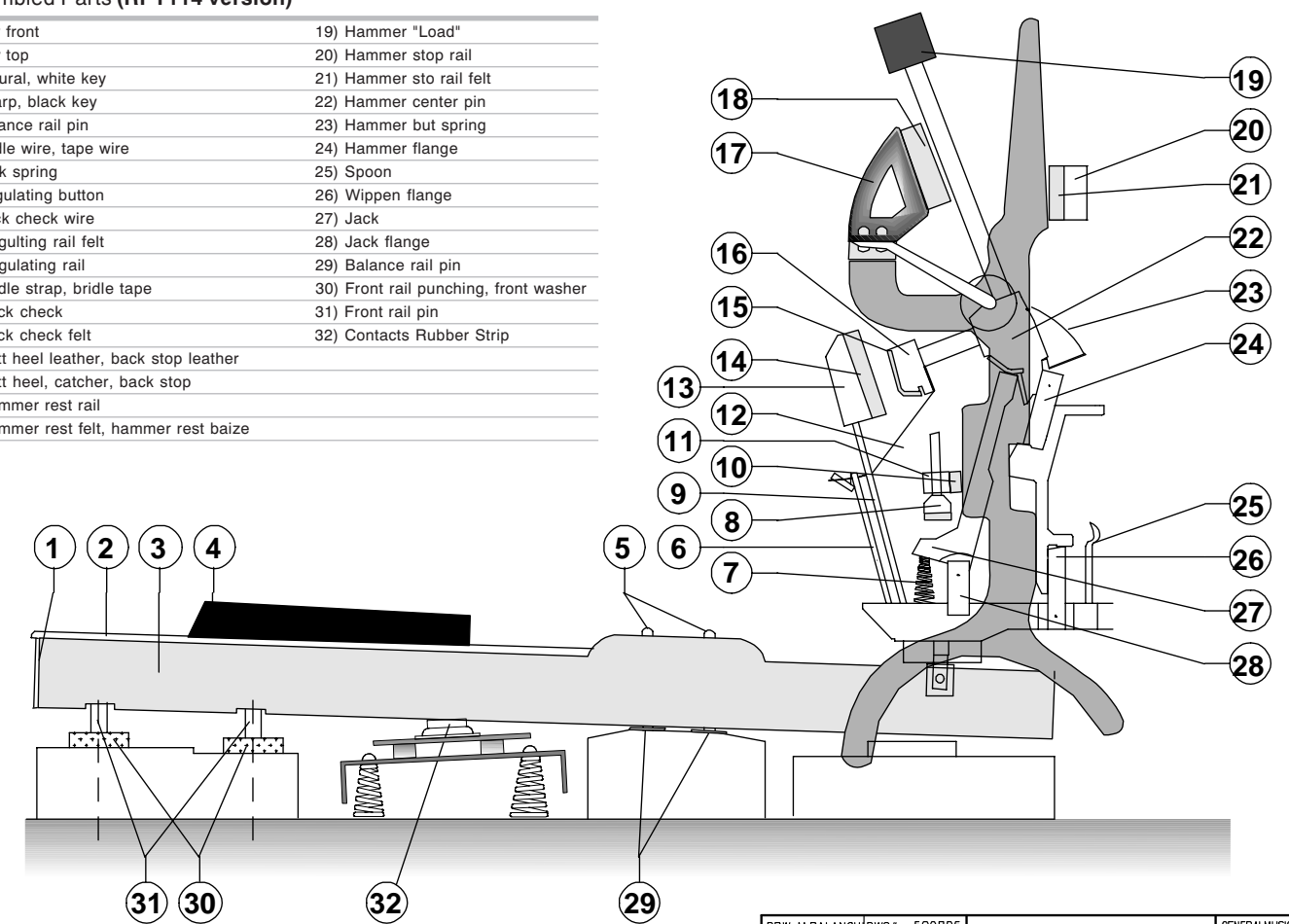

DRW. M.PALANGHI	DWG# 500805	RPT114	GENERALMUSIC S.p.A. ITALY
CKD. R.GIORGI	DISK: 57 PART:1/1	OPENING	ALL RIGHTS ARE RESERVED, NO COPIES
APP. M.GALANTI	REV: 23/10/97	INSTRUCTIONS	OR REPRODUCE THIS DOCUMENT WITHOUT
			WRITTEN CONSENT BY GENERALMUSIC.

**Keyboard calibration  
(RPT114 version)**

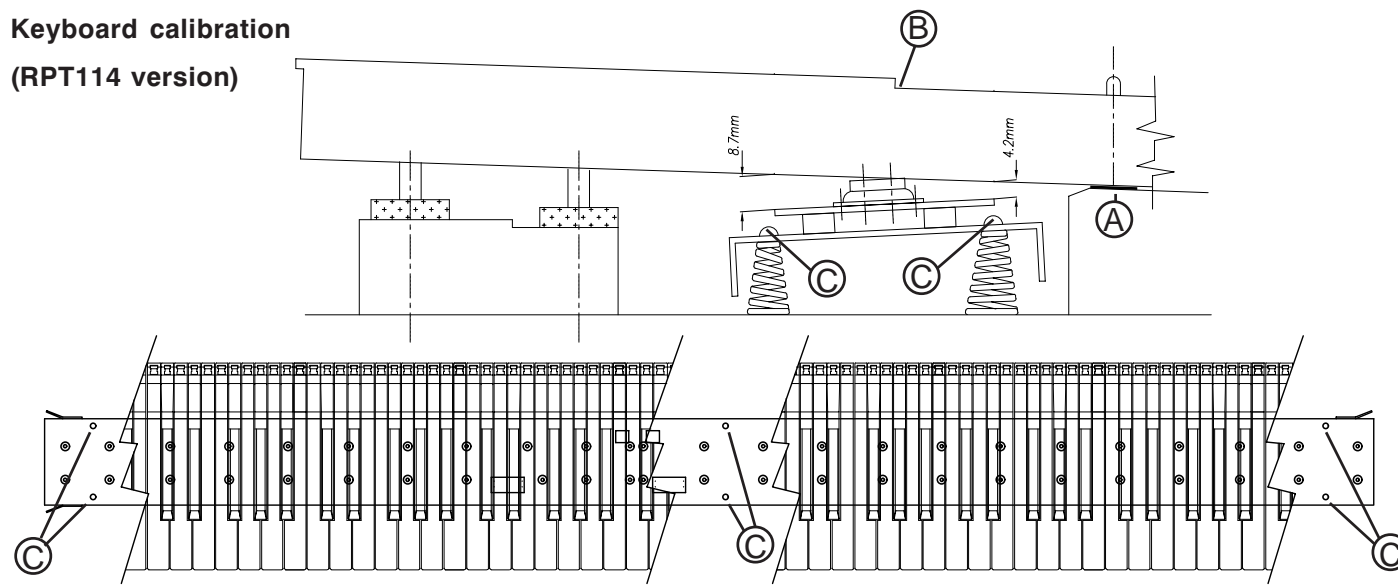

To access to the optical sensors remove all sharp and natural keys, we recommend to dispose the keys in order.

**Optical Keyboard**

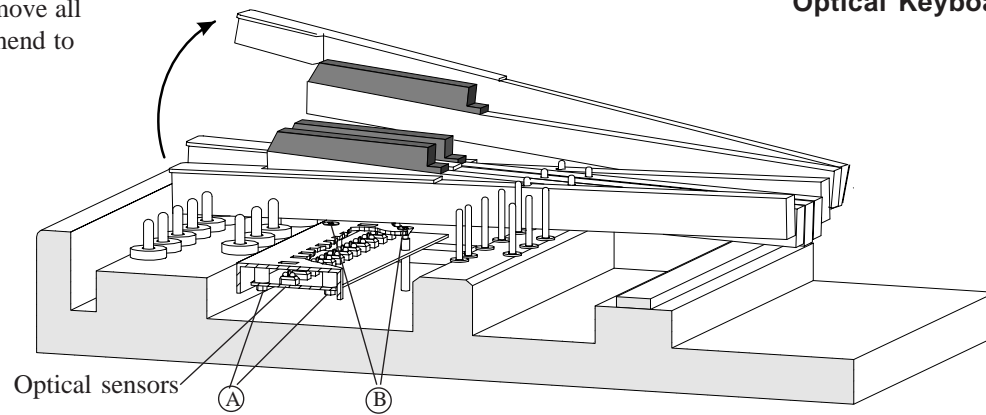

Once removed the keys unscrew the five screws (B) from the front panel of the contacts board and unscrew the forty-eight nuts (A) from the bottom.

**Assembled Parts (RPT114/O version)**

- |  |                                       |
|--|---------------------------------------|
| 1) Key front                             | 19) Hammer "Load"                     |
| 2) Key top                               | 20) Hammer stop rail                  |
| 3) Natural, white key                    | 21) Hammer stop rail felt             |
| 4) Sharp, black key                      | 22) Hammer center pin                 |
| 5) Balance rail pin                      | 23) Hammer but spring                 |
| 6) Bridle wire, tape wire                | 24) Hammer flange                     |
| 7) Jack spring                           | 25) Spoon                             |
| 8) Regulating button                     | 26) Wippen flange                     |
| 9) Back check wire                       | 27) Jack                              |
| 10) Regulating rail felt                 | 28) Jack flange                       |
| 11) Regulating rail                      | 29) Balance rail pin                  |
| 12) Bridle strap, bridle tape            | 30) Front rail punching, front washer |
| 13) Back check                           | 31) Front rail pin                    |
| 14) Back check felt                      | 32) Contacts Rubber Strip             |
| 15) Butt heel leather, back stop leather |                                       |
| 16) Butt heel, catcher, back stop        |                                       |
| 17) Hammer rest rail                     |                                       |
| 18) Hammer rest felt, hammer rest baize  |                                       |

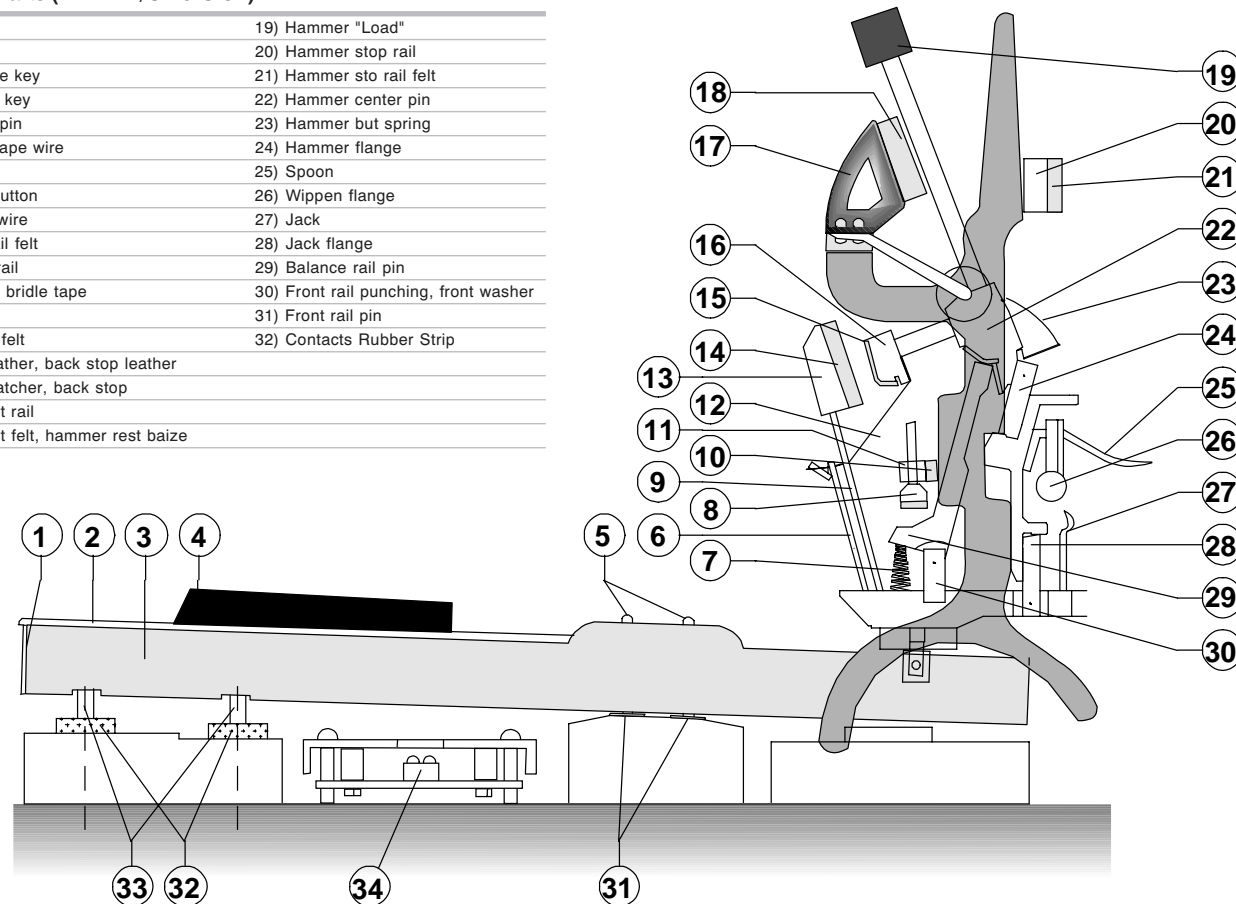

**RPT114 AUTOTEST CHART**

PROCEDURE	OPERATION	EVENT DESCRIPTIONS
<b>Start</b>	Loop the MIDI OUT with the MIDI IN sockets with a single MIDI cable. Apply the volume control to the center position	
	Turn on the instrument and press four times the "+" key within one second.	Three different tones must be sound.
<b>Controls</b>	Active the following controls: • "+" key • "-" key • DAMPER Pedal • SOFT Pedal • volume potentiometer.	At every action the instrument must play a "beep".  When all the buttons have been activated at least once time, three different tones must be sound, to mean a successful test end.
	<b>Note: The test must be performed within 20 seconds from the start, if this doesn't happen a sequence of beep are emitted, that meaning:</b>	
	<b>1st tones</b>	"+" key doesn't work or hasn't been activated
	<b>2nd tones</b>	"-" key doesn't work or hasn't been activated
	<b>3th tones</b>	MIDI loop is not present or a MIDI socket don't work properly
	<b>4th tones</b>	DAMPER pedal doesn't work or hasn't been activated.
<b>5th tones</b>	SOFT pedal doesn't work or hasn't been activated.	
<b>6th tones</b>	Volume potentiometer doesn't work or hasn't been activated.	
<b>Note</b>	The autotest operations can be performed only in the sequence specified above. All acoustical signals levels are fixed by the volume potentiometer position when the instrument is turned on. During test all normal keyboard function are disabled.	
	<b>To get the right dynamic response is very important to get perfect calibration of the keyboard.</b>	
<b>Keyboard calibrations.</b>	1) Level Keys:	Using standard circular paper spacers (contents in the calibration kit (970320), in position "A" to level: all 88 keys. The difference between all keys must be less than 0,1mm in point "B".
	2) Level Strip:	Turn the six screws "C" to reach the right distance between the keys and rubber printing circuit board that is 4,2mm±0,1 in one side and 8,7mm±0,1 from other side, as following showed.
<b>RPT114/O version keyboard sensors calibration</b>		
<b>ATTENTION</b>		
<i>The following operations serves to calibrate the keyboard sensors.</i>		
<b>If this is not required, turn off the instrument at this point, otherwise continue as described below.</b>		
<b>Optical sensors auto-calibration</b>	Turn on the instrument and press four times the "-" key within one second.	Three different tones must be sound.
	Press all sharp and natural keys one a time with the described precautions:	<ul style="list-style-type: none"> <li>• Play the keys with ppp (pianissimo) action.</li> <li>• Release the keys slowly to avoid any oscillation.</li> <li>• Be sure that the keys is fully pressed until the end stroke, but don't apply any extra pressure.</li> <li>• Perform previous operations as uniform as possible for all keys.</li> <li>• During calibration avoid any vibration to the keyboard.</li> </ul>
<b>Calibrations and Check</b>	Wait for a few seconds while the instrument memorises permanently the new calibration of the keyboard.	
	Could happen that keys aren't calibrated because: 1) optical sensors are dirty (look at the previous page how to access), 2) optical sensors aren't in the right tolerance range, 3) keys and pedals aren't calibrated in the right way.	
	If at least one of previous three events come true, you can hear a sequence of tones (having a gap of 0.5sec). The heard tone belongs to the key not well calibrated.	
	2 tone -> The upper threshold value is too high. 3 tones -> The lower threshold value is less. 4 tones -> Insufficient threshold span.	
<b>End</b>	Press the "-" button again and wait two seconds.	The instrument will re-start. If you didn't hear any sound all calibrations are correctly performed, otherwise you must calibrate the key corresponding to the heard sound. Switch-off the instrument.

RPT114 BLOCKS DIAGRAM

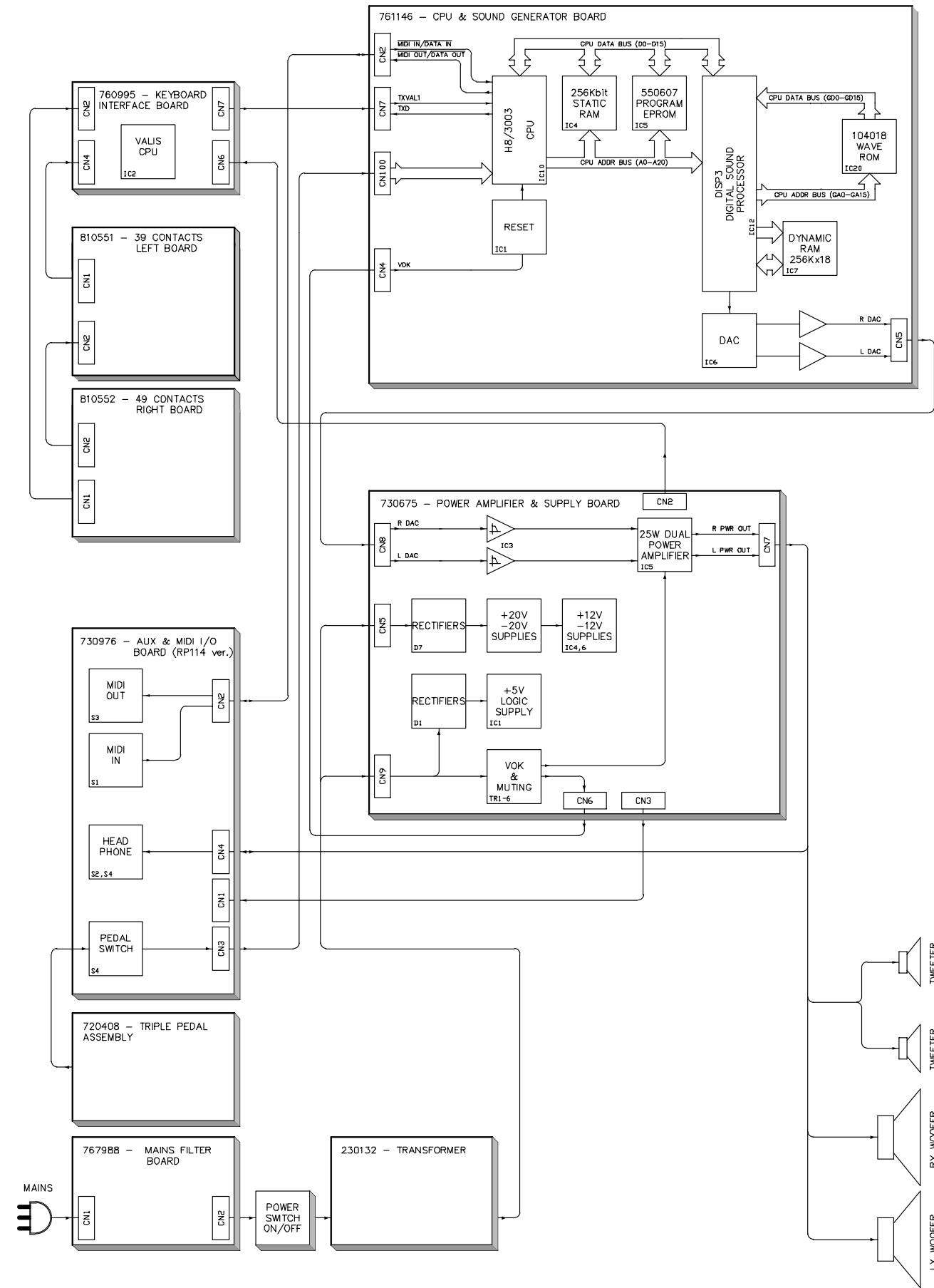

RPT114/O BLOCKS DIAGRAM

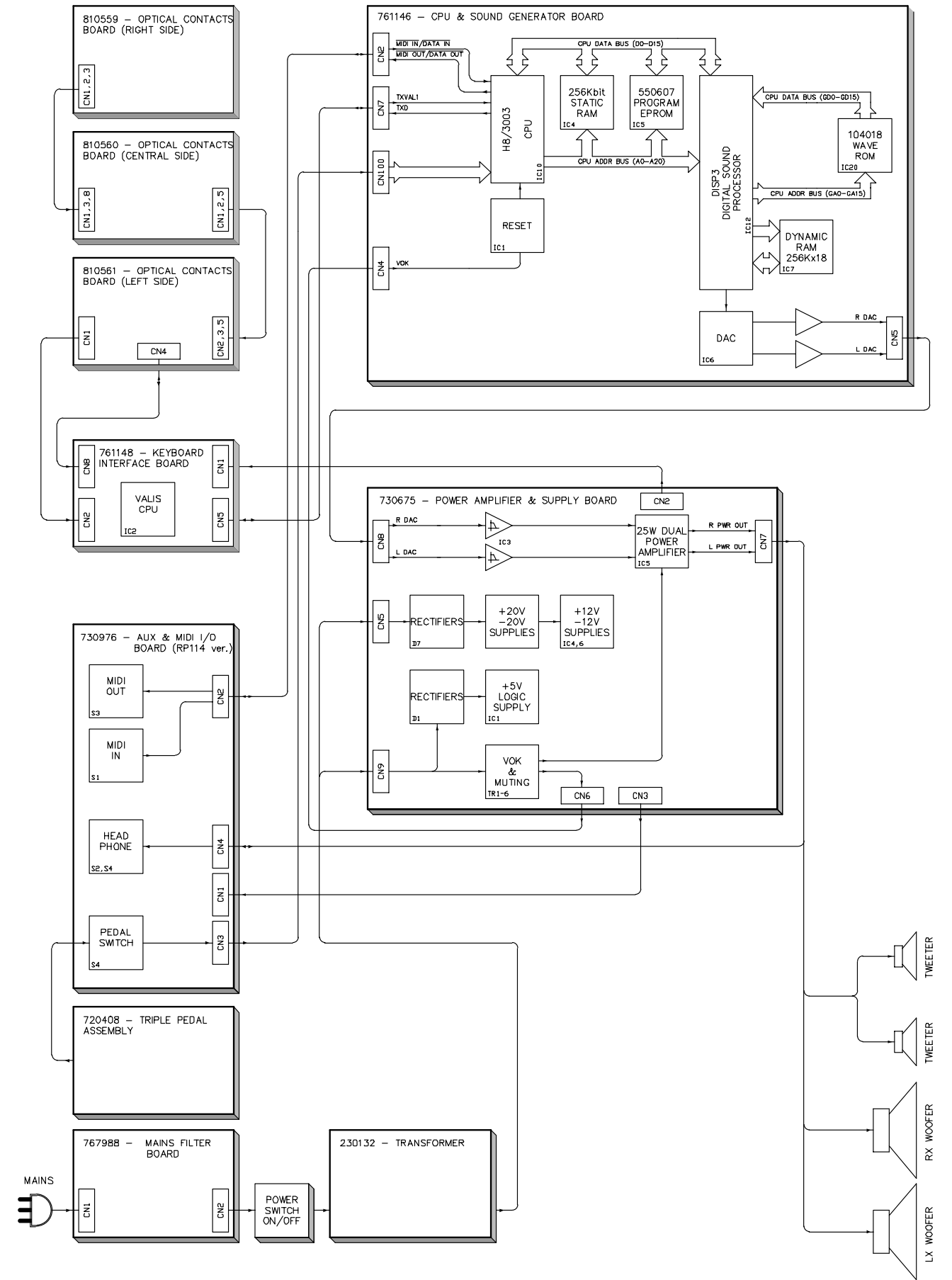



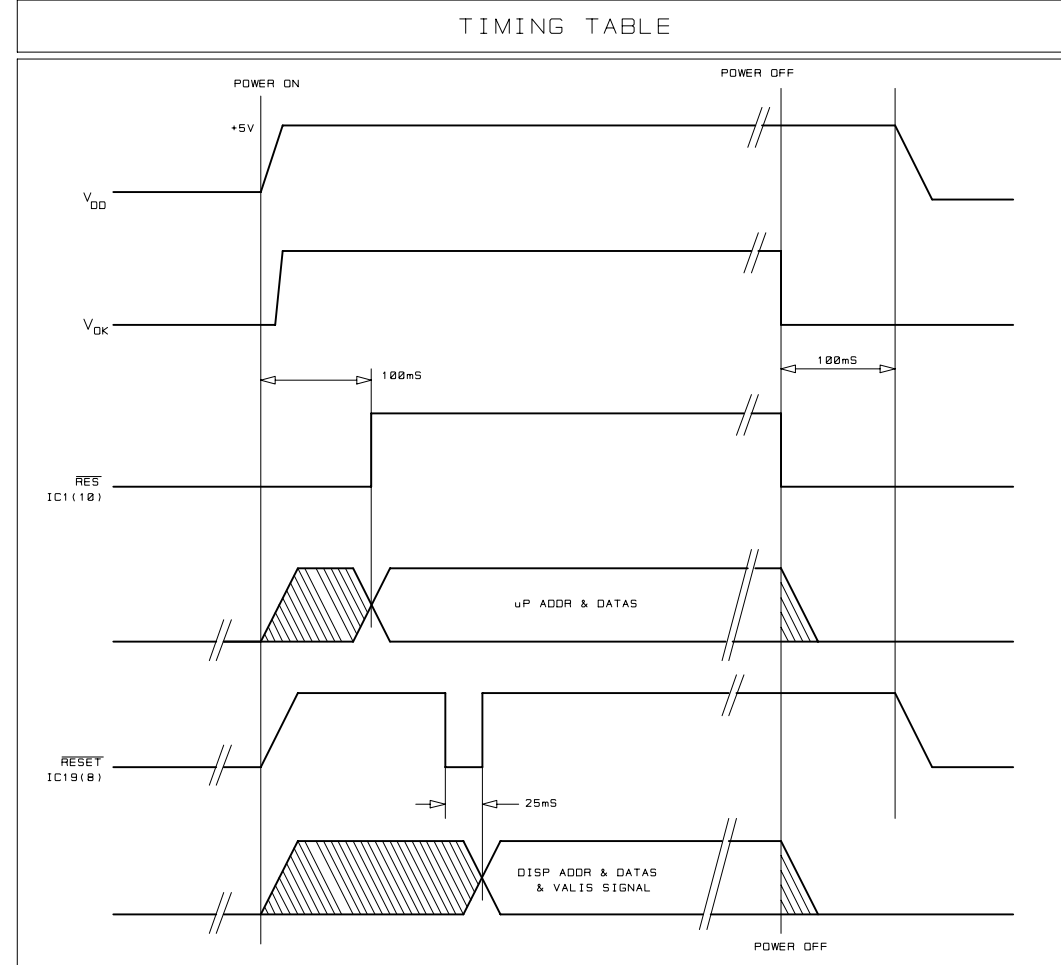
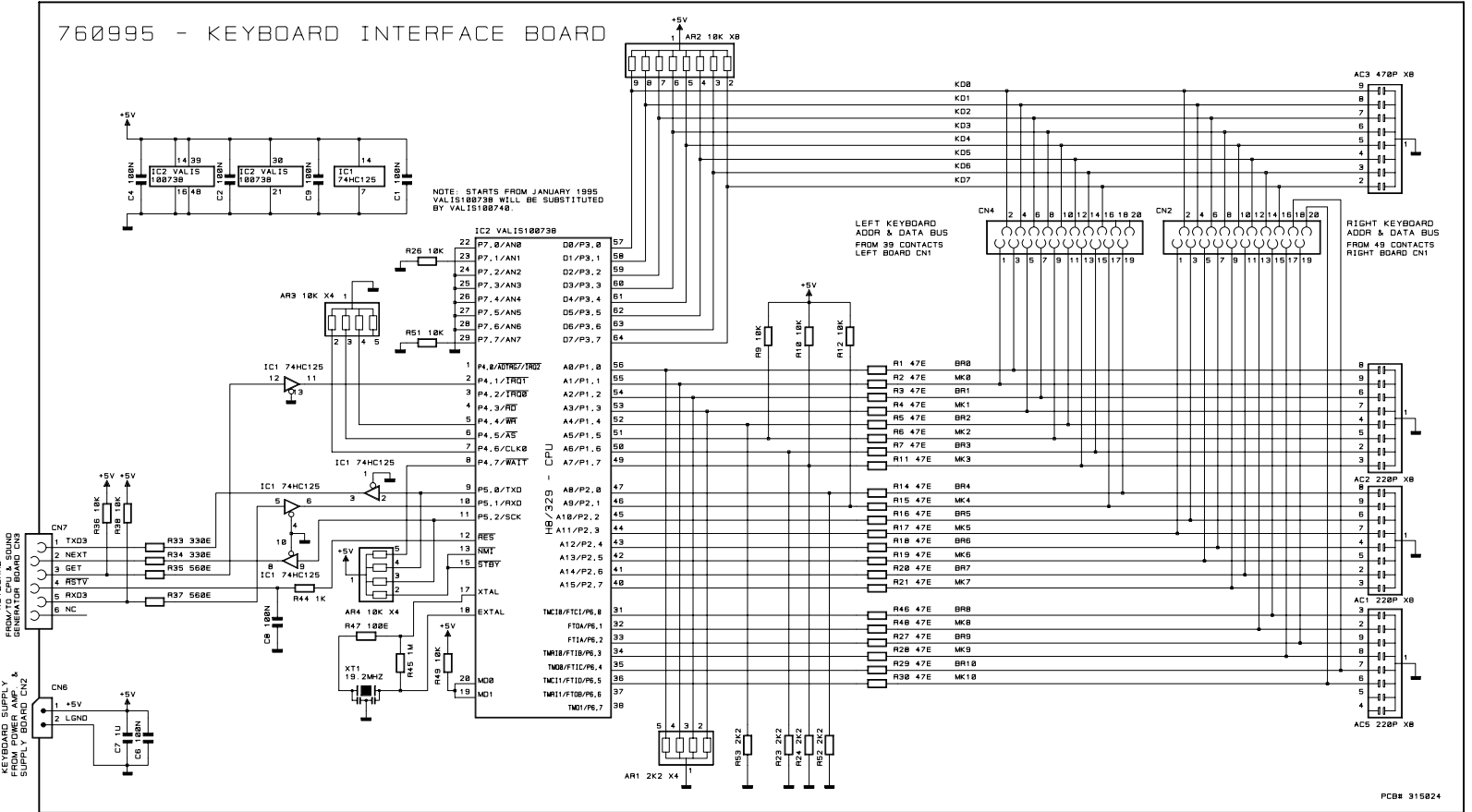
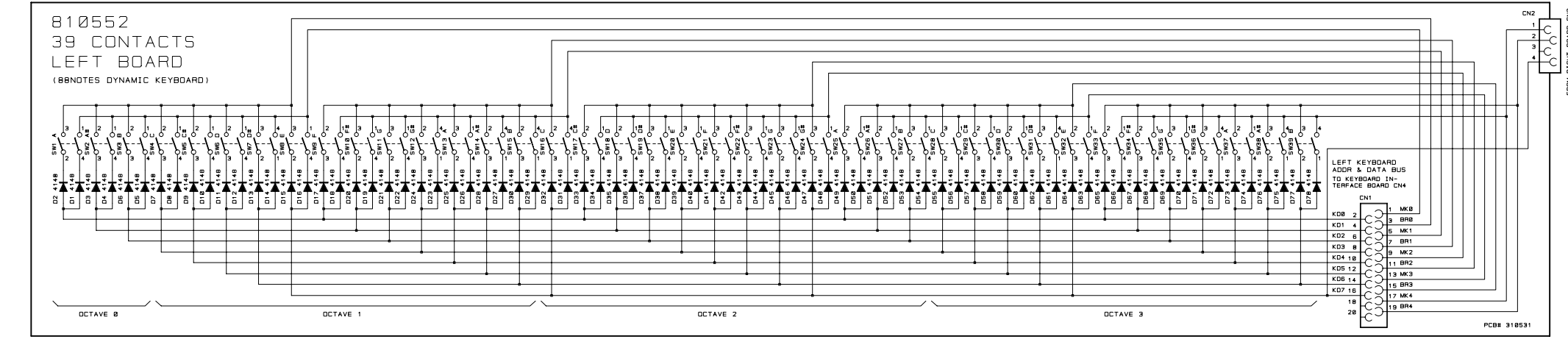
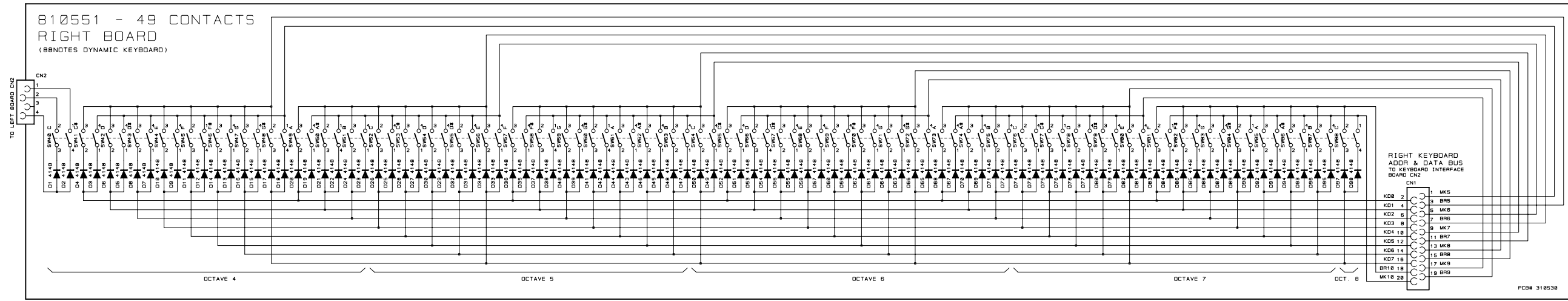

DRW BOCCATO	ENGR 508735	PCB# 318531 318530	GENERALMUSIC S.p.A. ITALY
CXD GIDREI	ENGR 39 PART. 1/1	SCHEMATIC DIAGRAM RPT 114	ALL RIGHTS ARE RESERVED. NO COPIES OR REPRODUCE THIS DOCUMENT WITHOUT WRITEN CONSENT BY GENERALMUSIC.
APP. GALANTI	REV: 12/87/96	CONTACTS BOARD & KEYBOARD INTERFACE BOARD	

761146 - CPU & SOUND GENERATOR BOARD

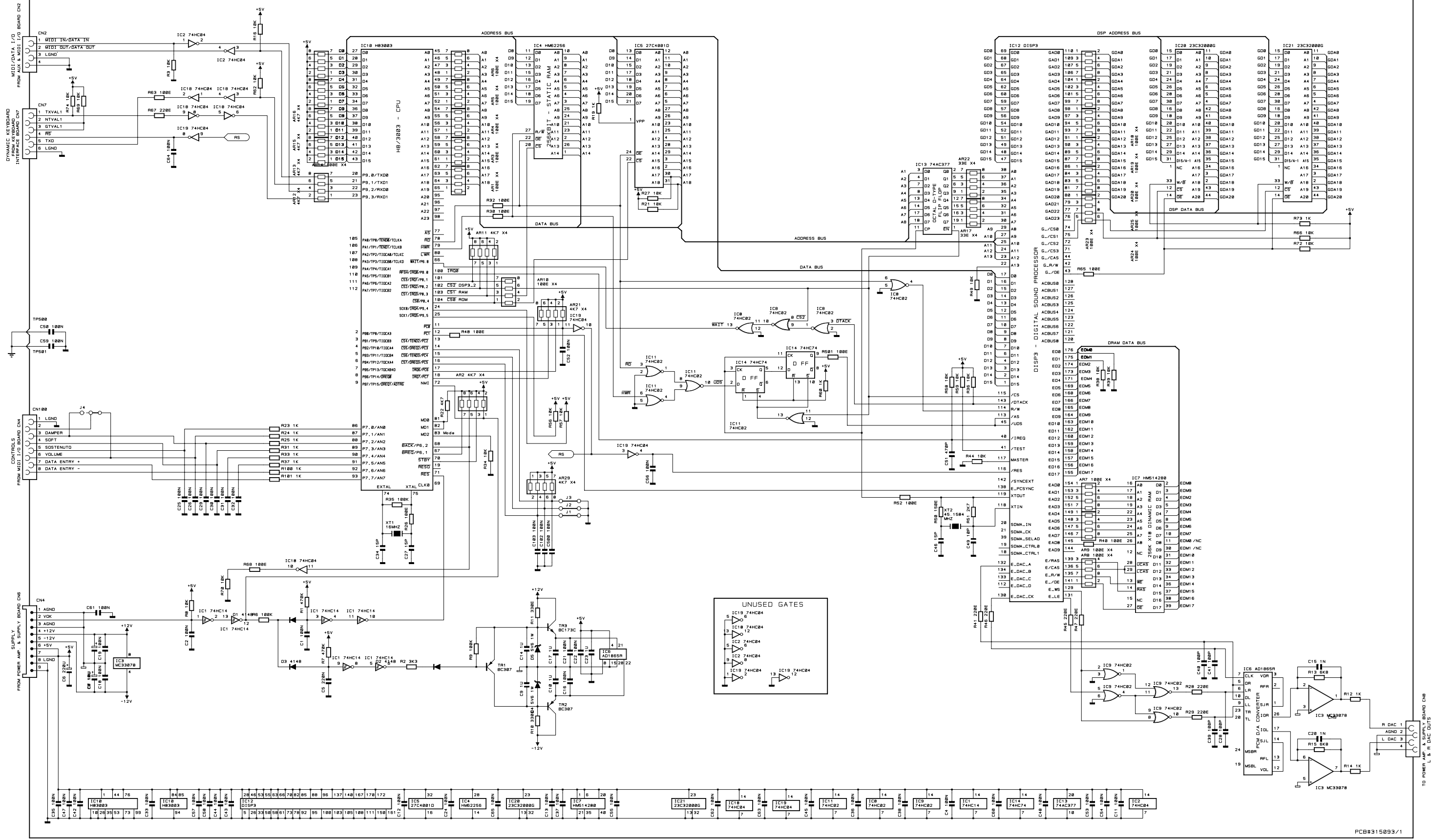

UNUSED GATES

- IC19 74HC14
- IC18 74HC14
- IC17 74HC14
- IC16 74HC14
- IC15 74HC14
- IC14 74HC14
- IC13 74HC14
- IC12 74HC14
- IC11 74HC14
- IC10 74HC14
- IC9 74HC14
- IC8 74HC14
- IC7 74HC14
- IC6 74HC14
- IC5 74HC14
- IC4 74HC14
- IC3 74HC14
- IC2 74HC14
- IC1 74HC14





810559 - OPTICAL CONTACTS BOARD (RIGHT SIDE)

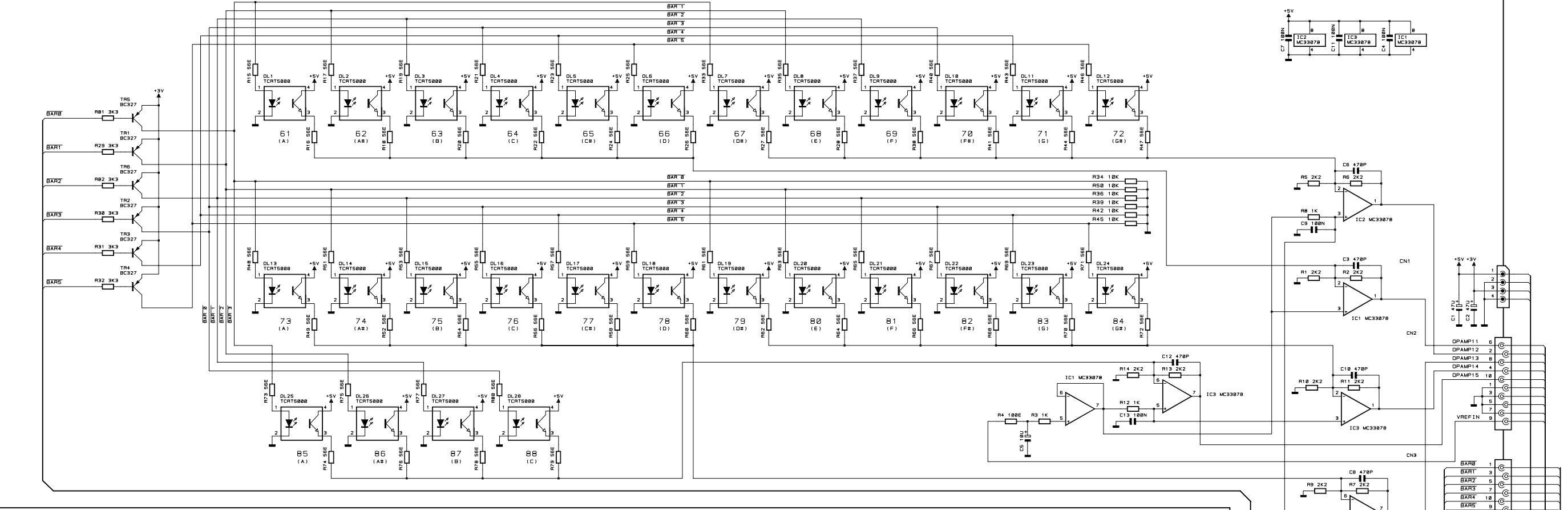

810560 - OPTICAL CONTACTS BOARD (CENTRAL SIDE)

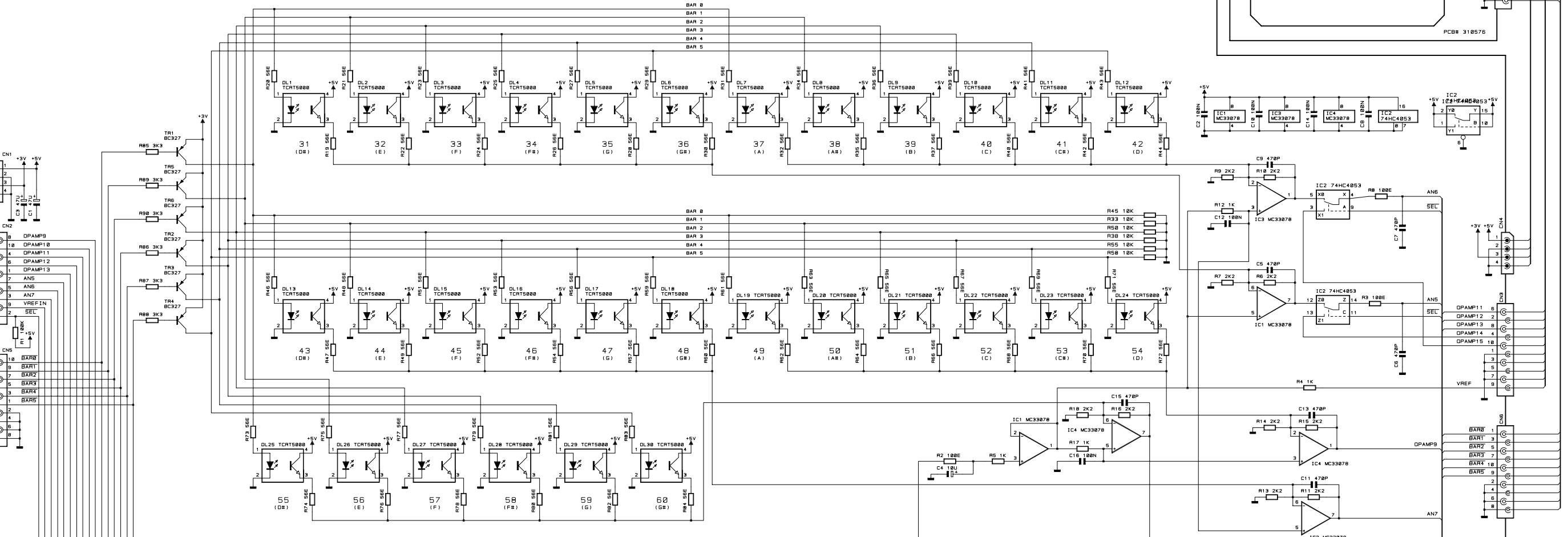

POWER SUPPLY FROM OPTICAL CONTACTS BOARD (LEFT SIDE) CN3

KEYBOARD SIGNAL FROM OPTICAL CONTACTS BOARD (LEFT SIDE) CN2

KEYBOARD SIGNAL FROM OPTICAL CONTACTS BOARD (LEFT SIDE) CN1

DRW. M. PALANZI	DWG. 580800	PCB 318575 - 318576	GENERAL MUSIC S.p.A. ITALY
CKD. P. FACCHIN	DSK# 57 PART. 1/1	RPT115	ALL RIGHTS ARE RESERVED. NO COPIES OR REPRODUCTIONS OF THIS DOCUMENT WITHOUT WRITTEN CONSENT BY GENERAL MUSIC
APP. M. GALANTI	REV. 22-10-97	SCHEMATIC DIAGRAM OPTICAL CONTACTS BOARDS (MID & RIGHT SIDE)	

## Spare Parts List (RPT114)

### Wooden Parts

#### 710449 Wooden Parts (Black hi-gloss)

261683	*	Shutter Rear Panel
261675	*	Pedals Box
261674	*	Speaker Rear Panel
261671	*	Lower Front Panel
261670	*	Right Foot
261669	*	Left Foot
261666	*	Cover
261665	*	Cross Bar
261662	*	Upper Front Panel
261661	*	Keyboard Panel
261658	*	Right Side
261657	*	Left Side
261564	*	Music Stand
261397	*	Sliding Cover
261390	*	Keyboard Bar
261389	*	Keyboard Cover

#### 710451 Wooden Parts (Black)

261689	*	Right Food
261688	*	Left Food
261683	*	Shutter Rear Panel
261681	*	Upper Front Panel
261680	*	Pedals Box
261677	*	Right Side
261676	*	Left Side
261674	*	Speaker Rear Panel
261672	*	Lower Front Panel
261667	*	Cover
261665	*	Cross Bar
261661	*	Keyboard Panel
261633	*	Music Stand
261628	*	Revolving Cover
261622	*	Keyboard Bar
261621	*	Keyboard Cover

#### 710452 Wooden Parts (Walnut)

261708	*	Rear Panel
261706	*	Right Foot
261705	*	Left Food
261698	*	Upper Front Panel
261696	*	Upper Right Side
261695	*	Lower Left Side
261694	*	Right Side
261693	*	Left Side
261684	*	Shutter Rear Panel
261682	*	Pedal Box
261673	*	Lower Front Panel
261668	*	Cover
261665	*	Cross Bar
261661	*	Keyboard Panel
261654	*	Music Stand
261648	*	Slider Cover
261642	*	Keyboard Bar
261641	*	Keyboard Cover

### Various

340159	3M Dual Lock Fastening (Specify mt)
340042	Plastic Handle
324407	Double Hinge (659 item)
324405	Hinge (661 item)
323069	Transparent Beating Rubber
210074	Black Acoustic Cloth
171331	Cover Left Fixing Bar
171330	Cover Right Fixing Bar
170389	Rear Cover Support Square
657241	Black tube
660405	Heat Sink Protection Grid
220115	8E Midrange Speaker
220114	8E Woofer
271202	User's Manual
140036	Screw Block (specify contacts)
030348	47UF 20% 100V Electrolytic Capacitor
660567	Controls & Outputs Box
652239	2 Keys <<>> Rubber Pad
347360	Gray/Black Knob
110285	Power Switch

## Brassed Pedals Assembly

### 720408 Brass Pedals Assembly

810168	*	Reed Switch Board (PCB#310272)
770717	*	Connection Cable
500063	*	Mechanical Parts
340105	**	Chassis Support
171261	**	Chassis Support
170880	**	Screen Panel
170875	**	Right Pedal
170874	**	Left Pedal
170873	**	Centre Pedal
170777	**	Pedal Return Spring
340500	*	3 Pedals Comand Lever
340499	*	3 Pedals Carring-out Lever
340274	*	Pedal Rubber
210016	*	1x10mm Adhesive Black Felt (specify mt)
190181	*	Pedals Clog
190178	*	Permanent Magnet
190015	*	Adhesive Rubber Foot
171263	*	Pedals Spring
070556	*	20K Lin (90deg. Stroke) Potentiometer

## Mains Filter Board

### 767988 Mains Filter Board (PCB# 315014/2)

230568	*	10mH 250Vac 1A AC Line EMI Coil "Siemens"
140010	*	3 Contacts P=10 Vert Terminal Block
110113	*	Fuse Clip 5x20mm 6A max (EU)
020493	*	100n 250Vac MKP EMI Capacitor "Siemens"
010545	*	4n7 250Vac
150021	*	Cord Lock
130294	*	Mains Cord (EU)

## Transformer Assembly

230132	*	Transformer 230Vac 130W
190133	*	Lateroid Insulator For Screw Block
140036	*	Screw Block (specify contacts)
110013	*	T1.25A Fuse 5x20mm
110011	*	T1A Fuse 5x20mm
110003	*	T3.15A Fuse 5x20mm
020493	*	100n 250Vac MKP EMI Capacitor "Siemens"

## CPU& Sound Generator Board

### 761146 CPU& Sound Generator Board (PCB#315093)

141012	*	Con V F 8 C P=1.27 Mmatch Amp
141011	*	6 Contacts Vert Female Connector
141010	*	4 Contacts Vert Female Connector
140889	*	Dual In Line Vert Male Strip (specify contacts)
140874	*	Single In Line Vert Male Strip (specify contacts)
140352	*	9 Contacts Hor Male Connector
106001	*	MC33078P Smd Dual LN J-Fet Operational Amp.
105009	*	50MHz DISP3
105006	*	HD6413003F16 Cpu Smd F=16MHz
104020	*	HM62256AFP-7T SOP Sram 256K Ta=70nS
104018	*	23C3200G SOP Rom 32Mbit Wave Rps
104010	*	HM514280AJ SOJ Dram 4M5bit Ta=70nS
103010	*	74HC04D SOIC Hex Inverter
103009	*	74HC02D SOIC Quad 2-In Nor Gate
103007	*	74HC74D SOIC Dual Flip-Flop
103004	*	AD1865R SOP 18bit D/A Converter
103000	*	74HC14D Soic Hex Inverter Schmitt Trigger
101501	*	74AC377DW SOIC Octal Dtype Flip Flop
090194	*	BC560 TO92 LN Pnp Transistor
090183	*	Bc550 To92 Ln Npn Transistor
081000	*	PMLL4148 Smd 100mA 75V Signal Diode
080241	*	5V6 1W 5% Zener Diode
010727	*	45.1584MHz Quartz Resonator
010704	*	16MHz Quartz Resonator
010599	*	1u 50V -20+80% Ceramic Cap. Multilayer
550607	*	27C1001 1Mbit Program Eprom
140877	*	Jumper For Contacts Strip (p=2.54mm)

## Power Amplifier & Supply Board

### 730675 Power Amplifier & Supply Board (PCB#310543)

141010	*	4 Contacts Vert Female Connector
140917	*	2 Contacts Vert Male Connector
140352	*	9 Contacts Hor Male Connector
140351	*	6 Contacts Hor Male Connector
140010	*	3 Contacts P=10 Vert Terminal Block
110119	*	Fuse Clip 10A max (EU) (US)
100958	*	TDA7265 Dual 25W Power Amplifier
100919	*	MC33078 Dual LN J-Fet Operational Amp.
100059	*	7805 +5V 1A Voltage Regulator
100045	*	7812 +12V 1A Voltage Regulator
100043	*	7912 -12V 1A Voltage Regulator
090856	*	J176 TO92 P-Channel J-Fet Transistor
090183	*	Bc550 To92 Ln Npn Transistor
080605	*	KBL02 4A 200V Bridge Rectifier Diode
080156	*	1N4002 1A 100V Rectifier Diode
080103	*	1N4148 100mA 75V Signal Diode

## Controls & Outputs Board

### 730977 Controls & Outputs Board (PCB#310587)

230569	*	FL5R200PNT EMI Coil For Signal
141012	*	Con V F 8 C P=1.27 Mmatch Amp
141010	*	4 Contacts Vert Female Connector
140917	*	2 Contacts Vert Male Connector
140877	*	Jumper For Contacts Strip (p=2.54mm)
140874	*	Single In Line Vert Male Strip (specify contacts)
140529	*	Microswitch 12V 50mA 0.25mm
140351	*	6 Contacts Hor Male Connector
140217	*	Horizontal Jack Stereo Slim Socket
140216	*	Horizontal Female 6 Poles Din Socket
140212	*	Horizontal Female 5 Poles Din Socket
140207	*	Horizontal Female Jack Socket
100035	*	6N138 Optocoupler
090194	*	BC560 TO92 LN Pnp Transistor
090183	*	Bc550 To92 Ln Npn Transistor
080705	*	Led 3mm 60deg Diffused Red
080103	*	1N4148 100mA 75V Signal Diode
074699	*	50Kb C.C. 11mm Horr. Rotary Po
030245	*	10u 50V 20% Vert Electrolytic Capacitor
010595	*	100n 50V -20+80% Ceramic Cap. Multilayer

## Keyboard Assembly

720543	Keyboard Assembly (TP10)
810552	* 39 Contacts Left Board For Dynamic Keyboard (PCB#310531)
340764	** 3 Dual Contacts Rubber Strip
340211	** 12 Dual Contact Rubber Strip
141018	** 20 Contacts Vert Female Connector
141010	** 4 Contacts Vert Female Connector
080103	** 1N4148 100mA 75V Signal Diode
810551	* 49 Contacts Right Board For Dynamic Keyboard (PCB#310530)
340212	** 13 Dual Contact Rubber Strip
340211	** 12 Dual Contact Rubber Strip
141018	** 20 Contacts Vert Female Connector
141010	** 4 Contacts Vert Female Connector
080103	** 1N4148 100mA 75V Signal Diode
760995	* Keyboard Interface Board (PCB#315024)
141018	** 20 Contacts Vert Female Connector
141011	** 6 Contacts Vert Female Connector
140918	** 2 Contacts Hor Male Connector
100740	** HD6433278 Cpu F=20MHz
100605	** 74HC125 Quad 3-State Buffer
050493	** Resistor Array 10K X4 1/8w 5%
050492	** 10Kx8 1/8w 5% Resistor Array
050414	** 2K2 X4 1/8w 5% Resistor Array
010726	** 19.2MHz Ceramic Resonator With Cap.
010662	** 220p 10% 50V X8 Cap Array
010661	** 47p 10% 50V X8 Cap Array
171615	* Contacts Boards Support Panel

## RPT114/O version Spare Parts List

### Keyboard Interface Board

#### 761148 Keyboard Interface Board (PCB#310577)

141018	*	20 Contacts Vert Female Connector
141011	*	6 Contacts Vert Female Connector
140918	*	2 Contacts Hor Male Connector
140874	*	Single In Line Vert Male Strip (specify cont.)
140872	*	4 Contatcs Hor Male Connector
104019	*	ST24W02 Smd 2Kbit Serial Access EEprom
100626	*	74HC4053 3x2ch Analog Multiplexer
100619	*	74HC32 Quad 2-Input Or Gate
100610	*	74HC245 Octal Bus Transceiver
100066	*	LM317 1.2-37V 1.5A Adjustable Regulator
010726	*	19.2MHz Ceramic Resonator With Cap.
010662	*	220p 10% 50V X8 Cap Array
550645	*	IC MICRO H8/329 PROG.<VALIS-O RPT 115>
140877	*	Jumper For Contacts Strip (p=2.54mm)

## Optical Contacts Assembly

### 720525 Optical Contacts Assembly

#### 810561 \* Optical Contacts B. (Left Side) (PCB#310574)

141018	**	20 Contacts Vert Female Connector
141013	**	Con V F 10c P=1.27 Mmatch Amp
140872	**	4 Contatcs Hor Male Connector
100919	**	MC33078 Dual LN J-Fet Operational Amp.
100626	**	74HC4053 3x2ch Analog Multiplexer
090153	**	BC327 TO92 Pnp Transistor
080900	**	OPTOELECT. REFLEX SENSOR TCRT5000
810560	* Optical Contacts B. (Central Side) (PCB#310575)	
141013	**	Con V F 10c P=1.27 Mmatch Amp
140872	**	4 Contatcs Hor Male Connector
100919	**	MC33078 Dual LN J-Fet Operational Amp.
100626	**	74HC4053 3x2ch Analog Multiplexer
090153	**	BC327 TO92 Pnp Transistor
080900	**	OPTOELECT. REFLEX SENSOR TCRT5000
810559	* Optical Contacts B. (Right Side) (PCB#310576)	
141013	**	Con V F 10c P=1.27 Mmatch Amp
140872	**	4 Contatcs Hor Male Connector
100919	**	MC33078 Dual LN J-Fet Operational Amp.
090153	**	BC327 TO92 Pnp Transistor
080900	**	OPTOELECT. REFLEX SENSOR TCRT5000
660579	*	Optical Contacts Board Support

## Note:

Each spare part is single quantity unless otherwise specified.

Asterisk prefix explanation:

Omitted = First level spare part.

One asterisk = Second level, part of previous listed first level part.

Two asterisk = Third level, part of previous listed second level part.

Three asterisk = .....

Any request for not above mentioned part must encompass specific description including:

- 1) Model name,
- 2) Section name,
- 3) Module code,
- 4) Reference name,
- 5) Quantity number.