

THESE COMPONENTS GO BETWEEN POINTS "P" AND "D" IN AO-28-1 AMPLIFIERS (WITH NO CODE LETTER ONLY) INSTEAD OF THOSE SHOWN AT LEFT

(* SEE NOTE)

SELECT FOR CHANNEL BALANCE (MOUNTED ON "P" TERMINAL)

NOTE:
R52, R53, R54, C32 IN AO-28-1 AMPLIFIERS (WITH NO CODE LETTER ONLY)

MODEL B3, C3, RT3

Title			PREAMPLIFIER TYPE AO-28		
Size	Document Number			REV	
B	-----	-----		1.0	
Date:	April 20, 1995		Sheet	1 of 1	

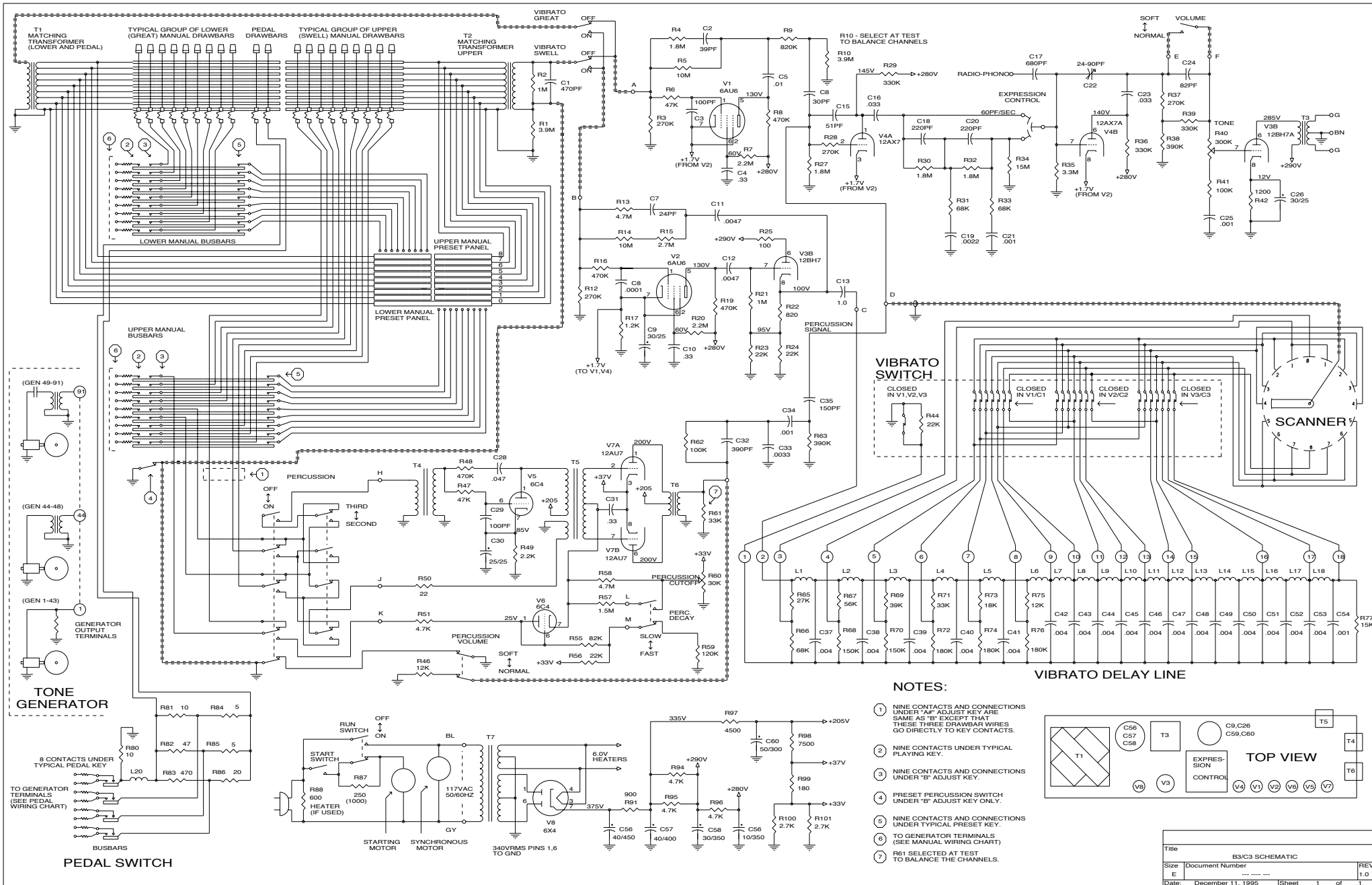

NOTES:

- ① NINE CONTACTS AND CONNECTIONS UNDER "A" ADJUST KEY ARE SAME AS "B" EXCEPT THAT THESE THREE DRAWBAR WIRES GO DIRECTLY TO KEY CONTACTS.
- ② NINE CONTACTS UNDER TYPICAL PLAYING KEY.
- ③ NINE CONTACTS AND CONNECTIONS UNDER "B" ADJUST KEY.
- ④ PRESET PERCUSSION SWITCH UNDER "B" ADJUST KEY ONLY.
- ⑤ NINE CONTACTS AND CONNECTIONS UNDER TYPICAL PRESET KEY.
- ⑥ TO GENERATOR TERMINALS (SEE MANUAL WIRING CHART)
- ⑦ R61 SELECTED AT TEST TO BALANCE THE CHANNELS.

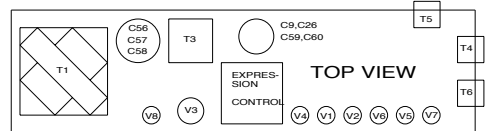

Title	B3/C3 SCHEMATIC	
Size	Document Number	REV
E	-----	1.0
Date:	December 11, 1995	Sheet 1 of 1

