

INTERFACING THE EML 401 MODULE WITH THE EML 101
OR EML 500* KEYBOARD SYNTHESIZERS

EML 101 (Note Diagram I-1) Connect as indicated. The TUNE rotary control is used to tune the 401 oscillators and filters in relation to the 101's sources. They may be tuned to unison or to varied intervals.

EML 500 (Note Diagram I-2) To control the oscillators of the 401 from the EML 500, simply connect the CONTROL VOLTAGE output of the EML 500 to the oscillator control input of the EML 401 marked - Vext. Tuning the 401's oscillators to either unison or intervals in respect to the EML 500's is accomplished with the TUNE control knob on the 401. Initiating the 401's voltage control envelope generator is realized by taking a patchcord and connecting the GATE output from the EML 500 to the TRIGGER input of the EML 400 Sequencer or of the EML 401 module.

In order to have the Filter track the Keyboard control voltage a patchcord must be connected from the MULT jack to the filter's Vext jack. Carefully note Diagrams I-1 and I-2.

* The EML 500 synthesizer does require some modifications in order to make a complete and effective interfacing.

ELECTROCOMP[®] SEQUENCER

ELECTRONIC MUSIC LABS., INC. VERNON, CONN. 06066

13
12
11
10
9
8
7
6
5
4
3
2
1
0
-1
OCTAVE

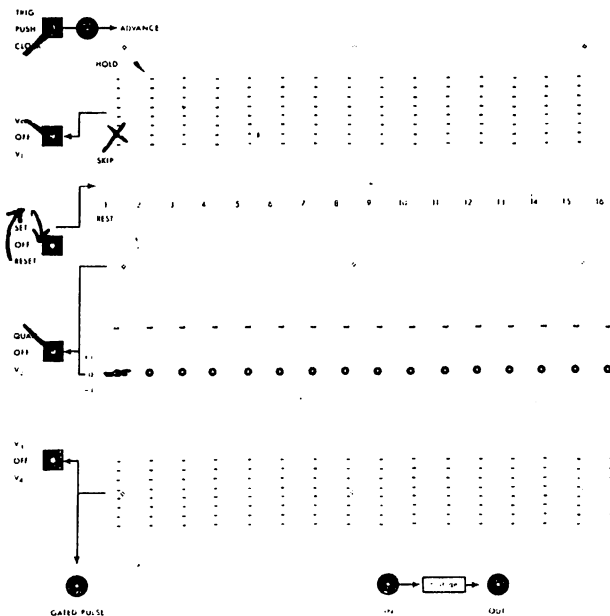
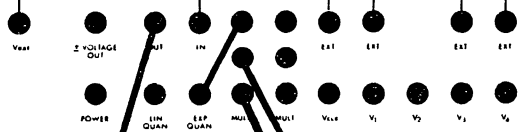
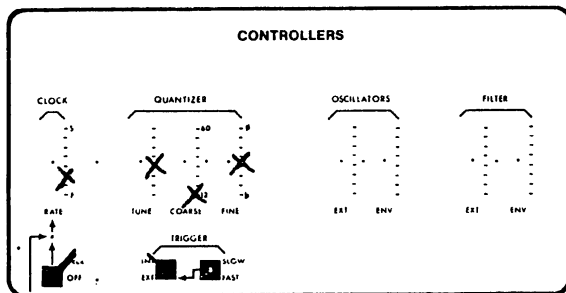

KEYBOARD CONTROL OF VC01 & VC02.
Adjust the frequency controls of the 200's oscillators so that the oscillators just "tick" at a rate of 1 per second or less. The Swing control is used for octavation.

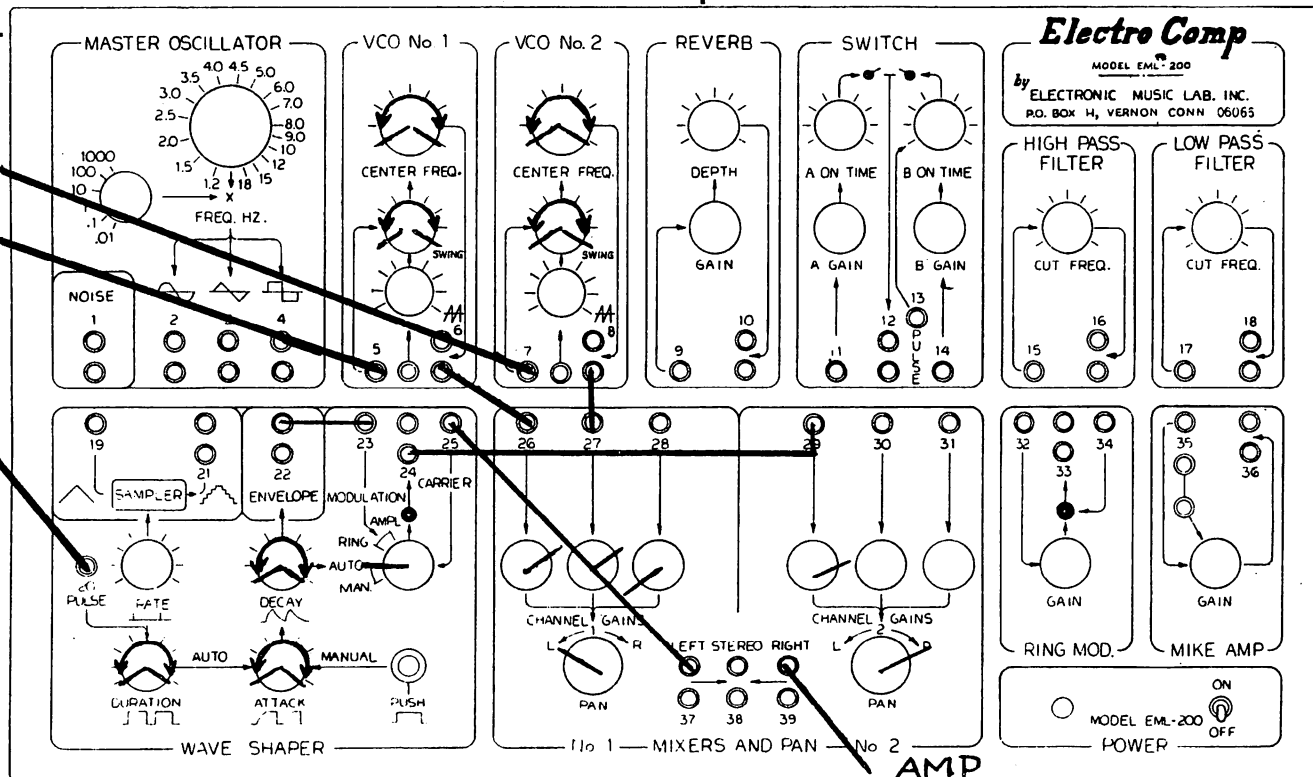

EML 200 STUDIO SYNTHESIZER
as the SOURCE and MODIFIER
SECTION for the EML 400
SERIES SEQUENCER.

Electro Comp

MODEL EML-200
by ELECTRONIC MUSIC LABS., INC.
P.O. BOX 14, VERNON CONN 06065

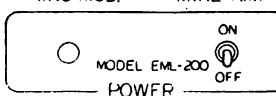
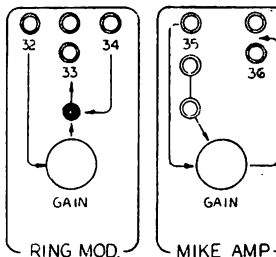
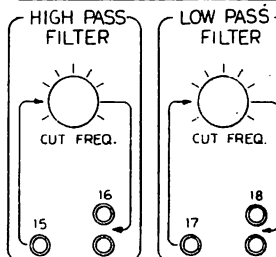

AMP

100/101 MODIFICATION FOR SEQUENCER OWNERS

This modification permits Oscillator 3 and Oscillator 4 to be controlled from the Sequencer.

1. Remove the 4 or 5 allen screws located around the periphery of the synthesizer's panel.
2. While facing the 100/101 lift the right side of panel out first (the OUTPUT MIXER side). Slide the panel to the right and out.
3. Set the panel on a firm surface on its control knobs. Locate board #1 (see below).

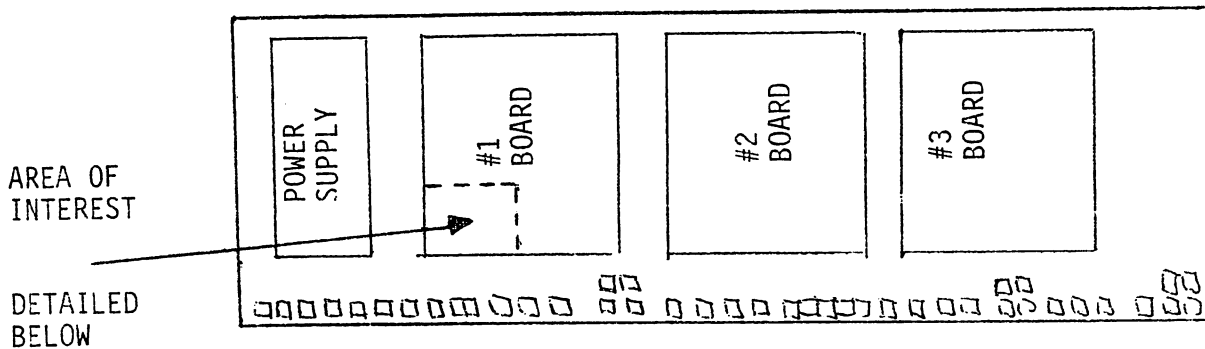

For 100's and 101's before serial number 410:

4. Locate the KB2 jack, CM# jack on 101's. Disconnect the colored wire from the jack and tape the end so it won't short. This wire will not be connected to anything.
5. Replace the KB2 jack, CM# jack on 101's, with the pulse type jack supplied. Mount it so that the slanted corner faces the same direction as the other jack. Wire as shown:

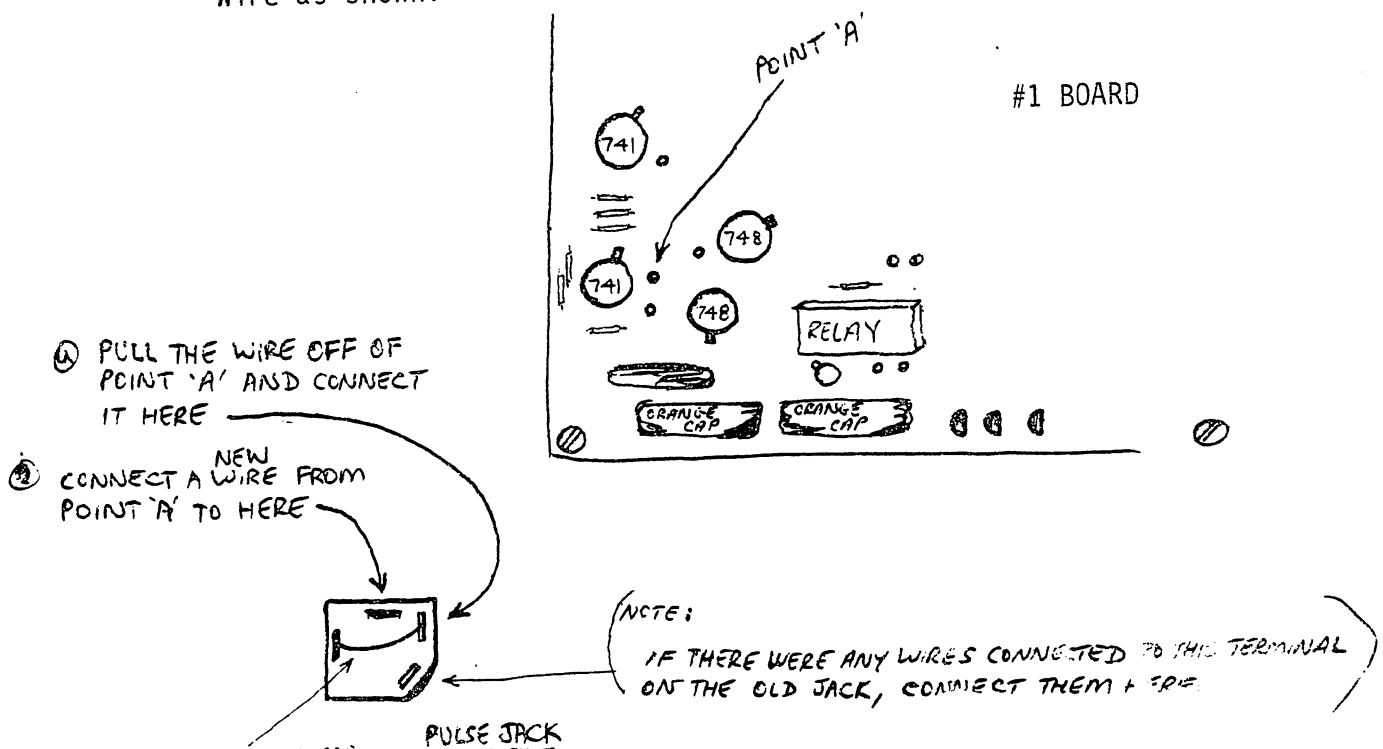

For 101's from serial number 410 to number 646.

4. (same as previous page)

5. (same as previous page)

Wire as shown:

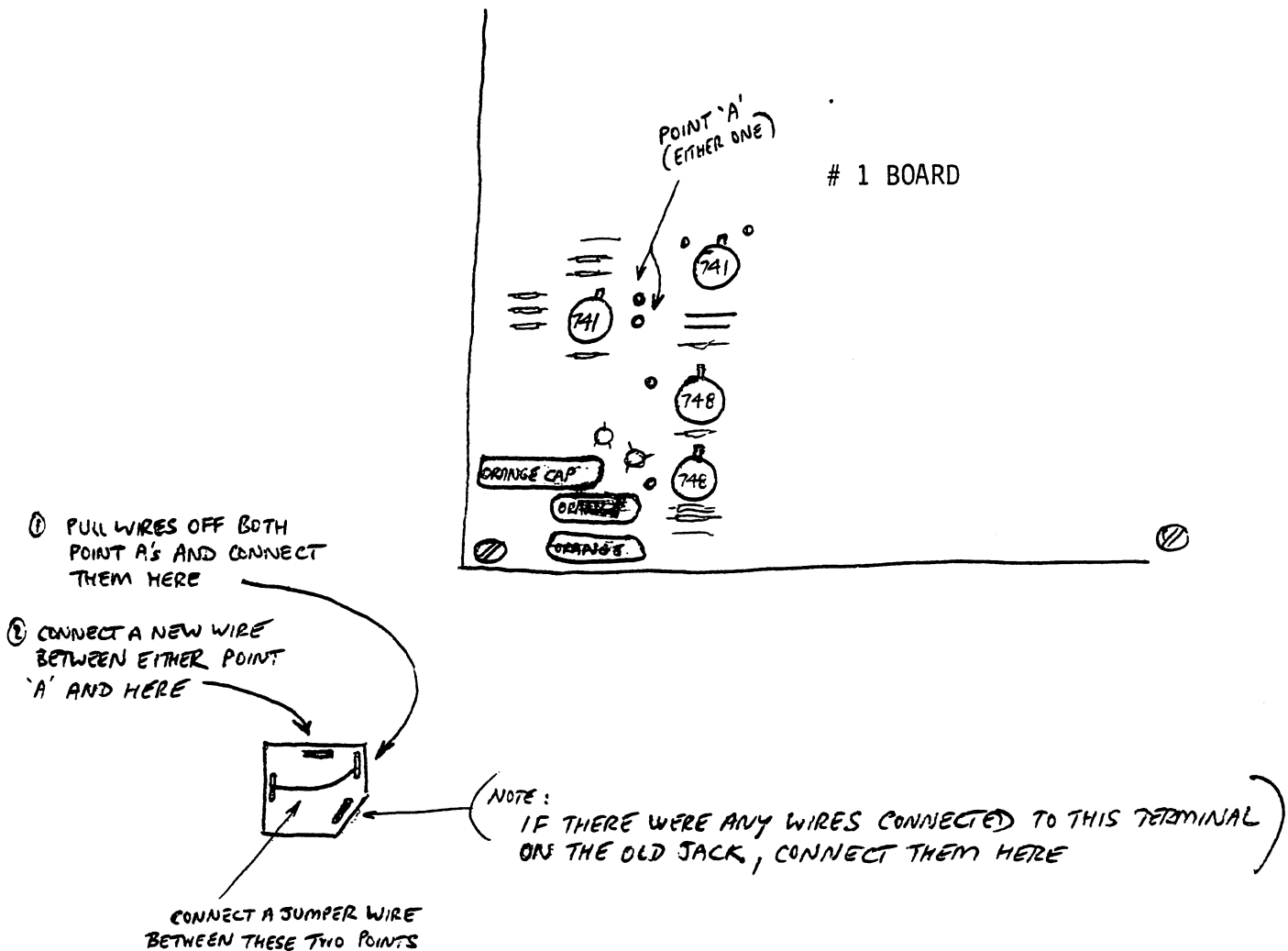

If this procedure generates any questions, please don't hesitate to call or write before proceeding.

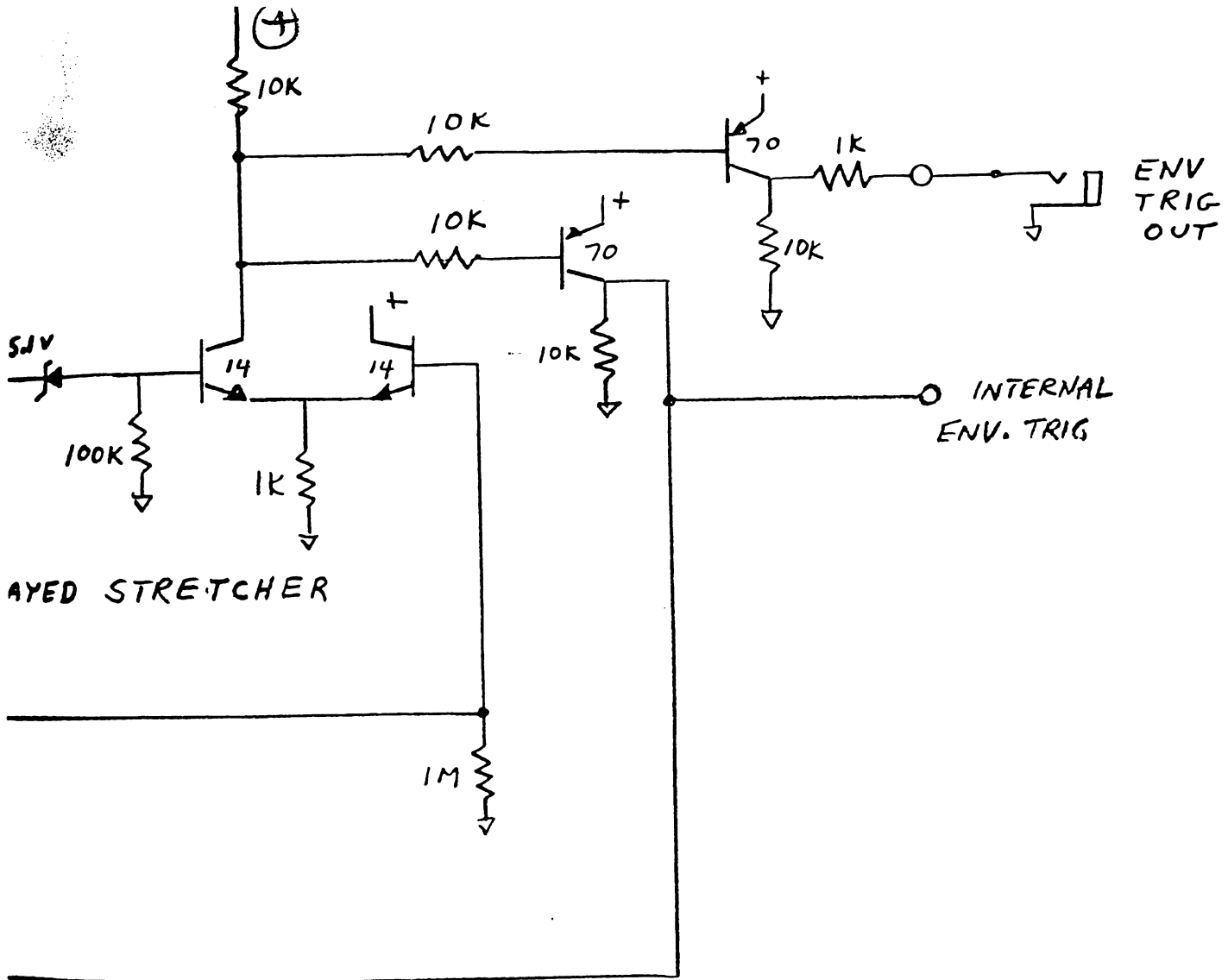

TRIGGER CIRCUITS

ELECTRONIC MUSIC LABS, INC.
 SEQUENCER
 5-16-74 JJM
 REV 4-14-77 KK

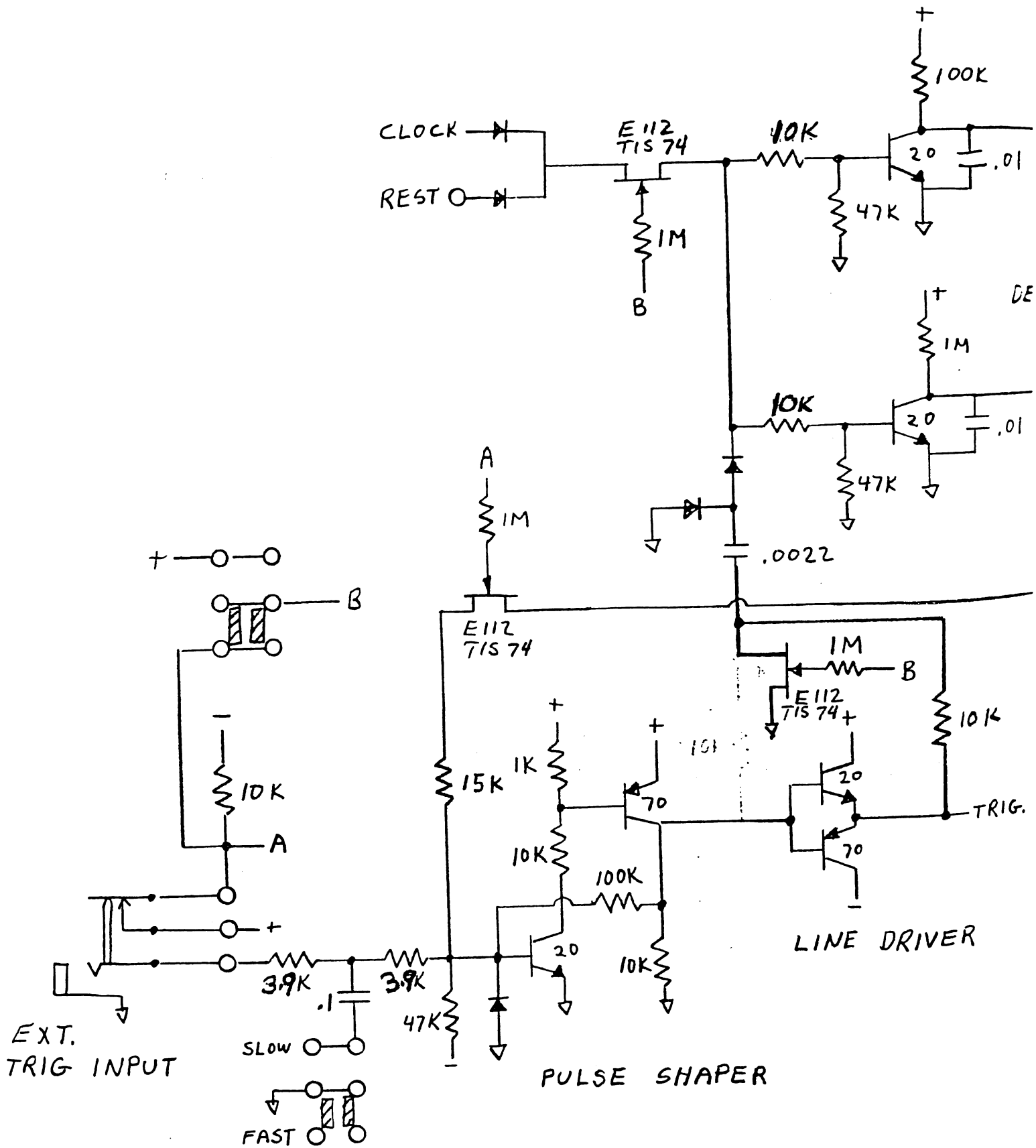

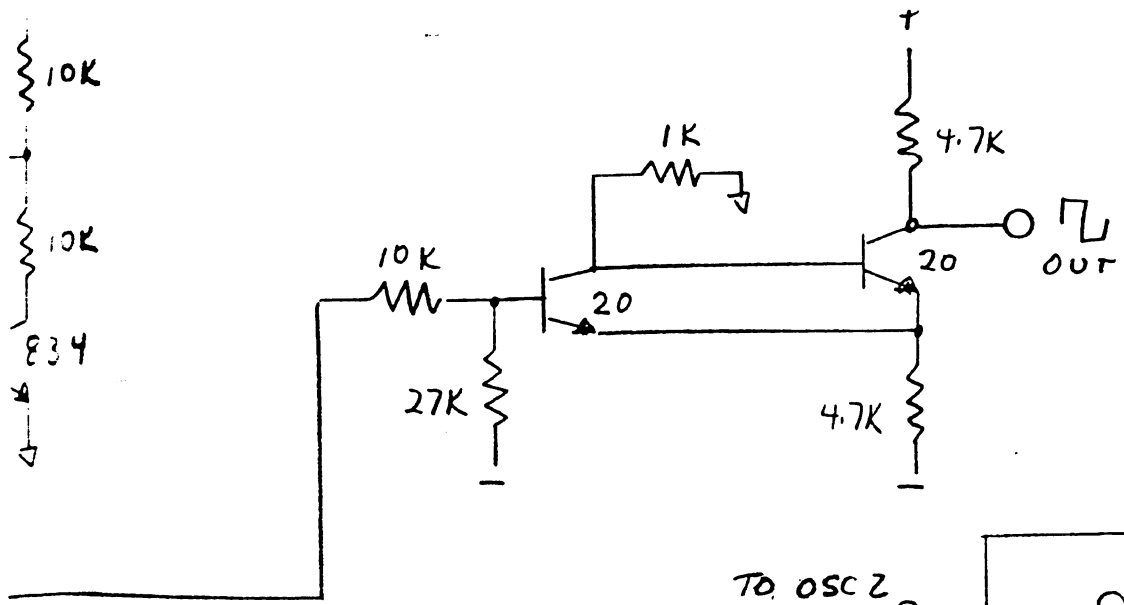

MASTER OSC

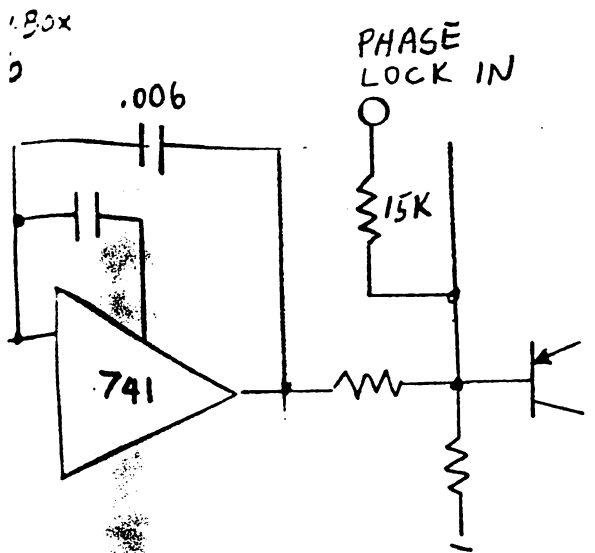
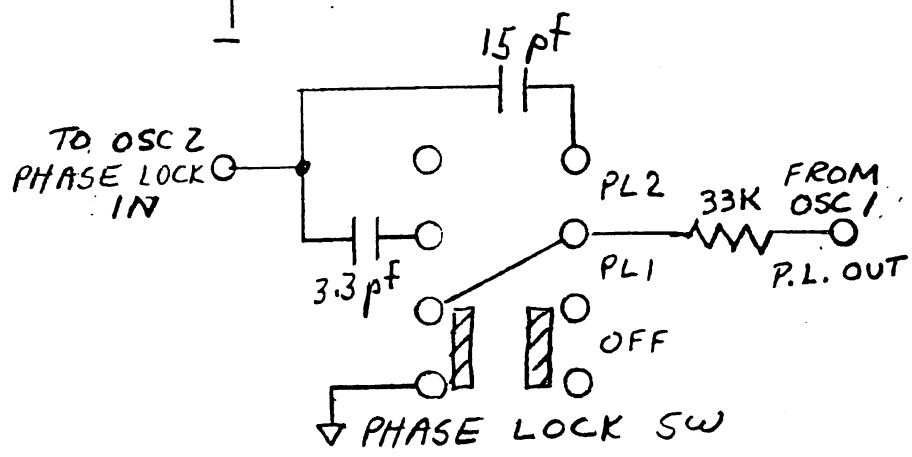

SLAVE OSC.
SAME AS MASTER OSC

ELECTRONIC MUSIC LABS,
SEQUENCER
5-20-74 JJM
REV 4-14-77 KIK

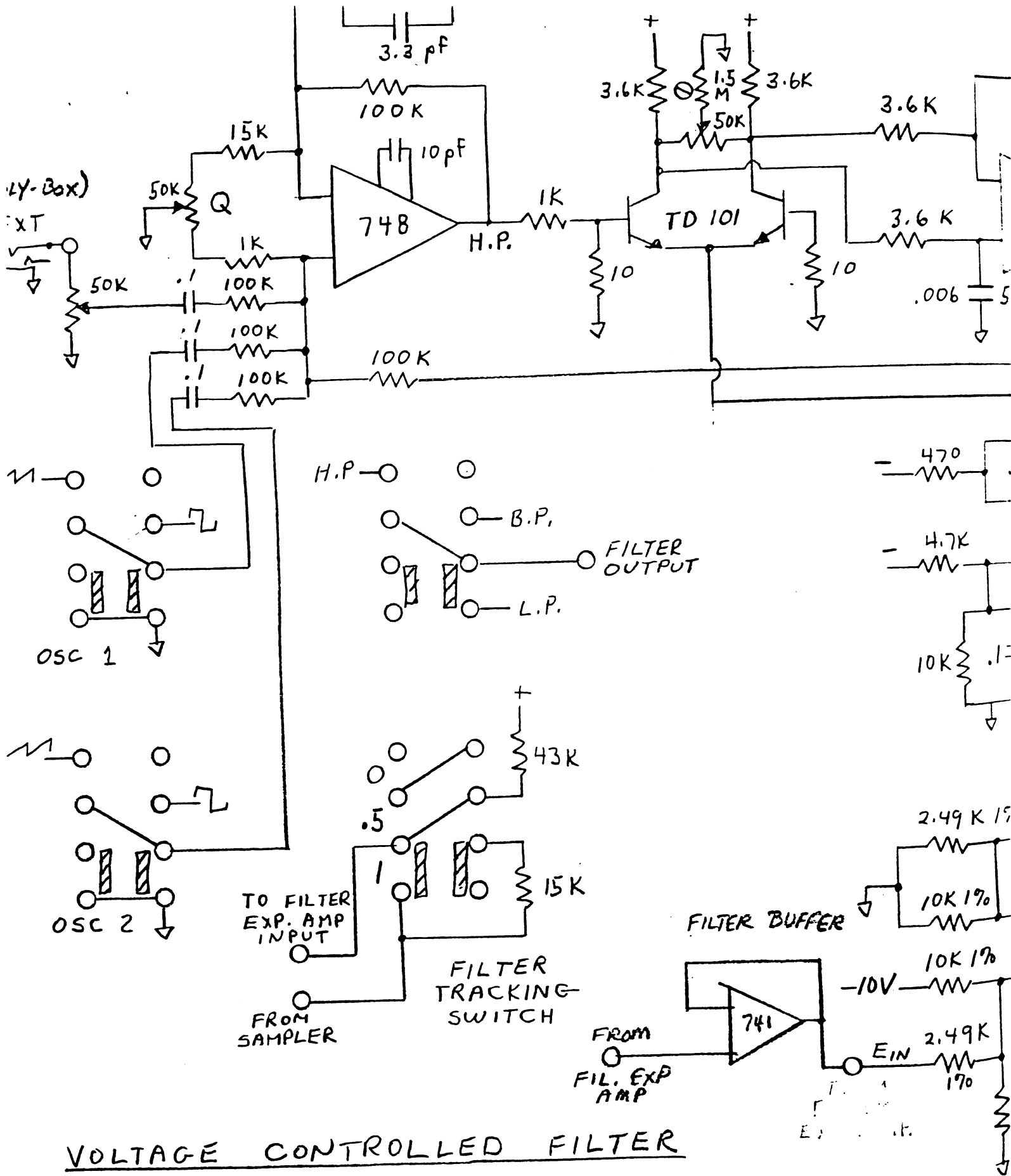

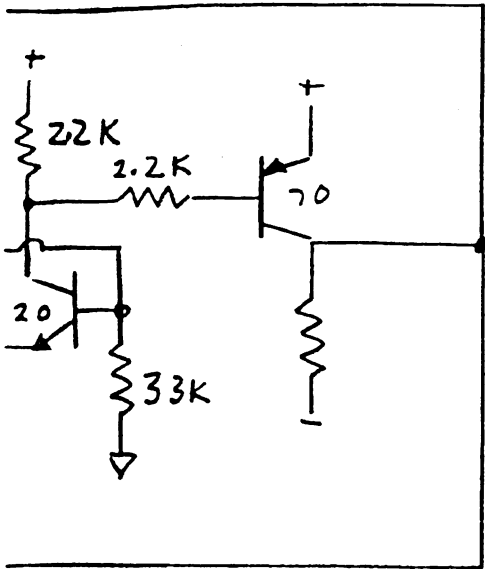

ξ D

VOLTAGE CONTROLLED ENVELOPE

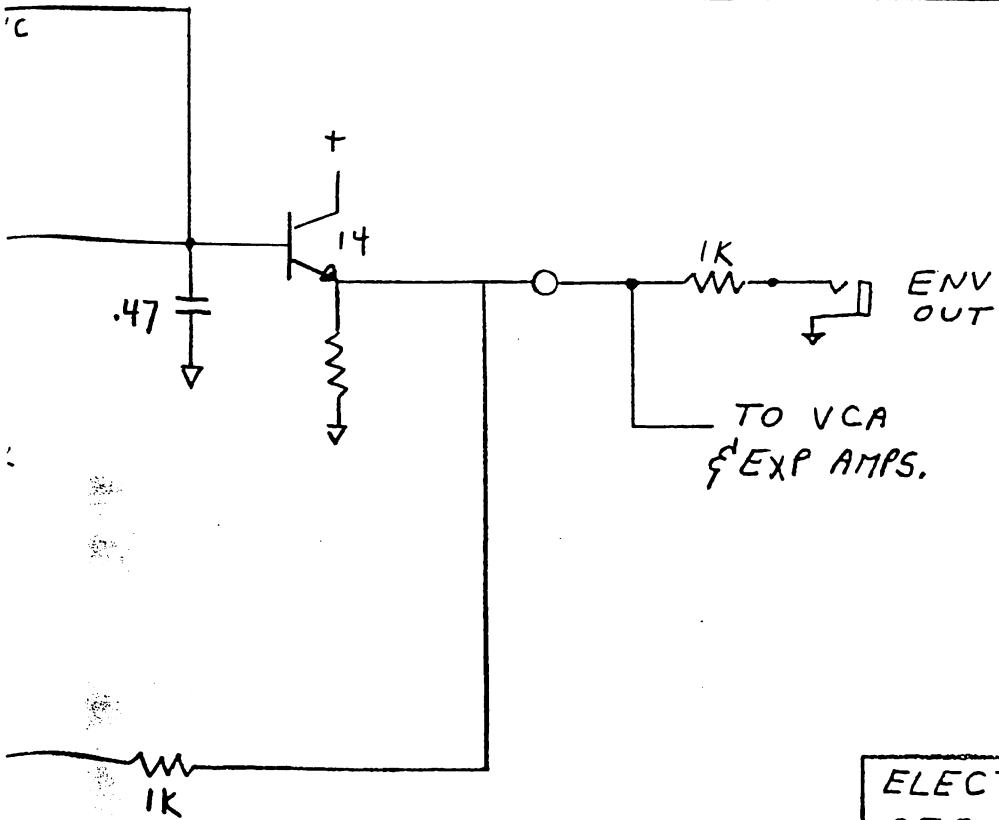

ELECTRONIC MUSIC LABS., INC.
 SEQUENCER
 5-20-74
 REV 4-14-77 KK

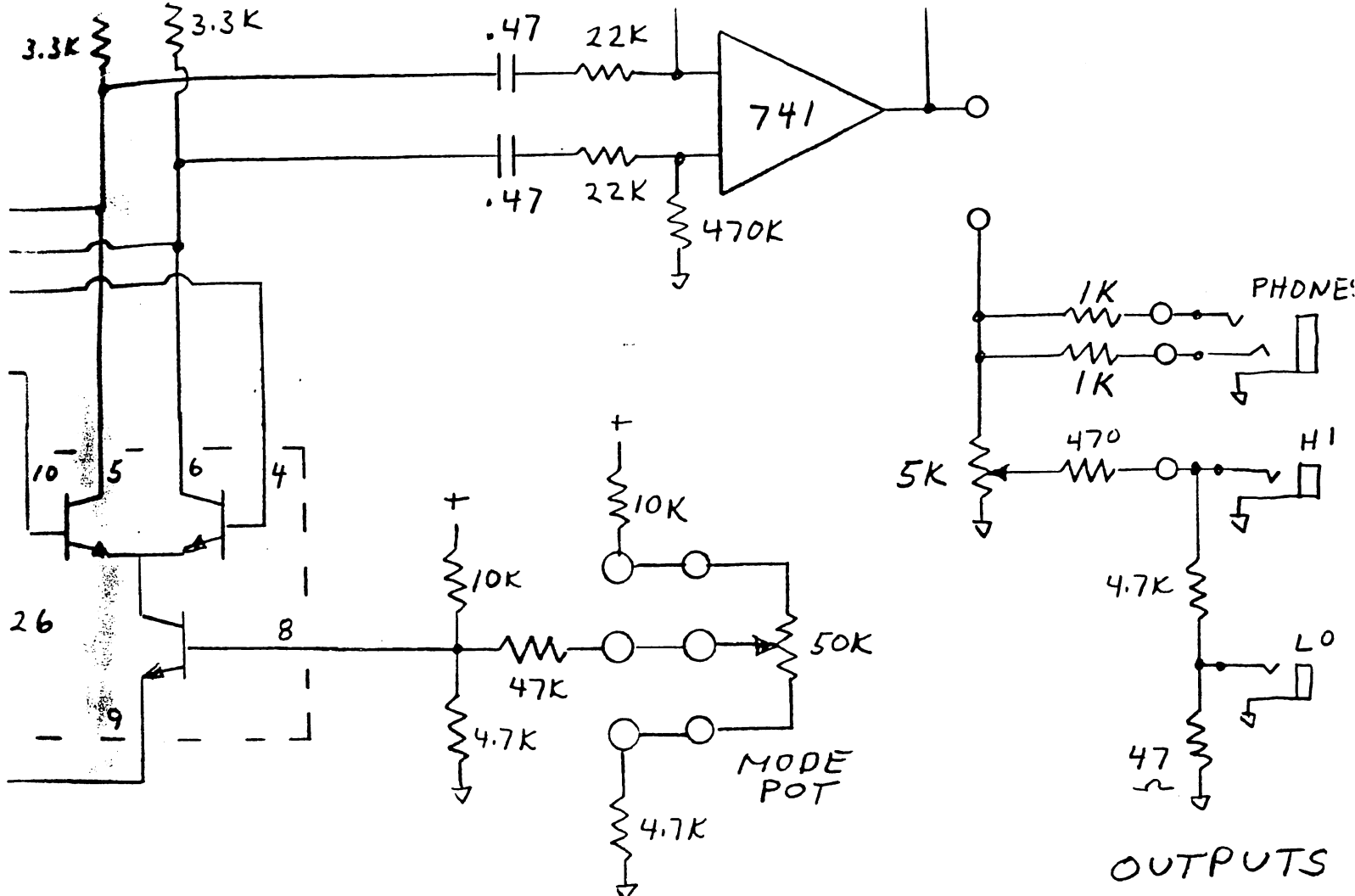

VCA

ELECTRONIC MUSIC LABS., INC
 SEQUENCER
 5-20-74
 REV 4-14-77 KAL

10K

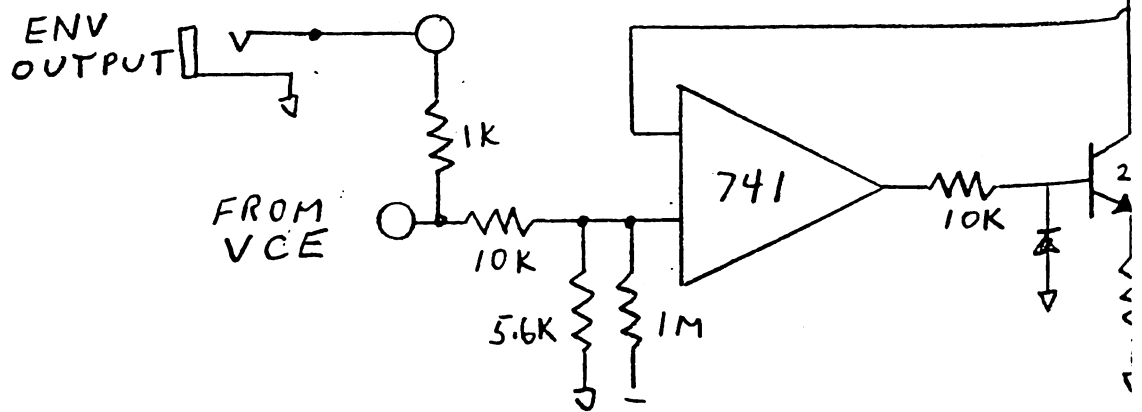
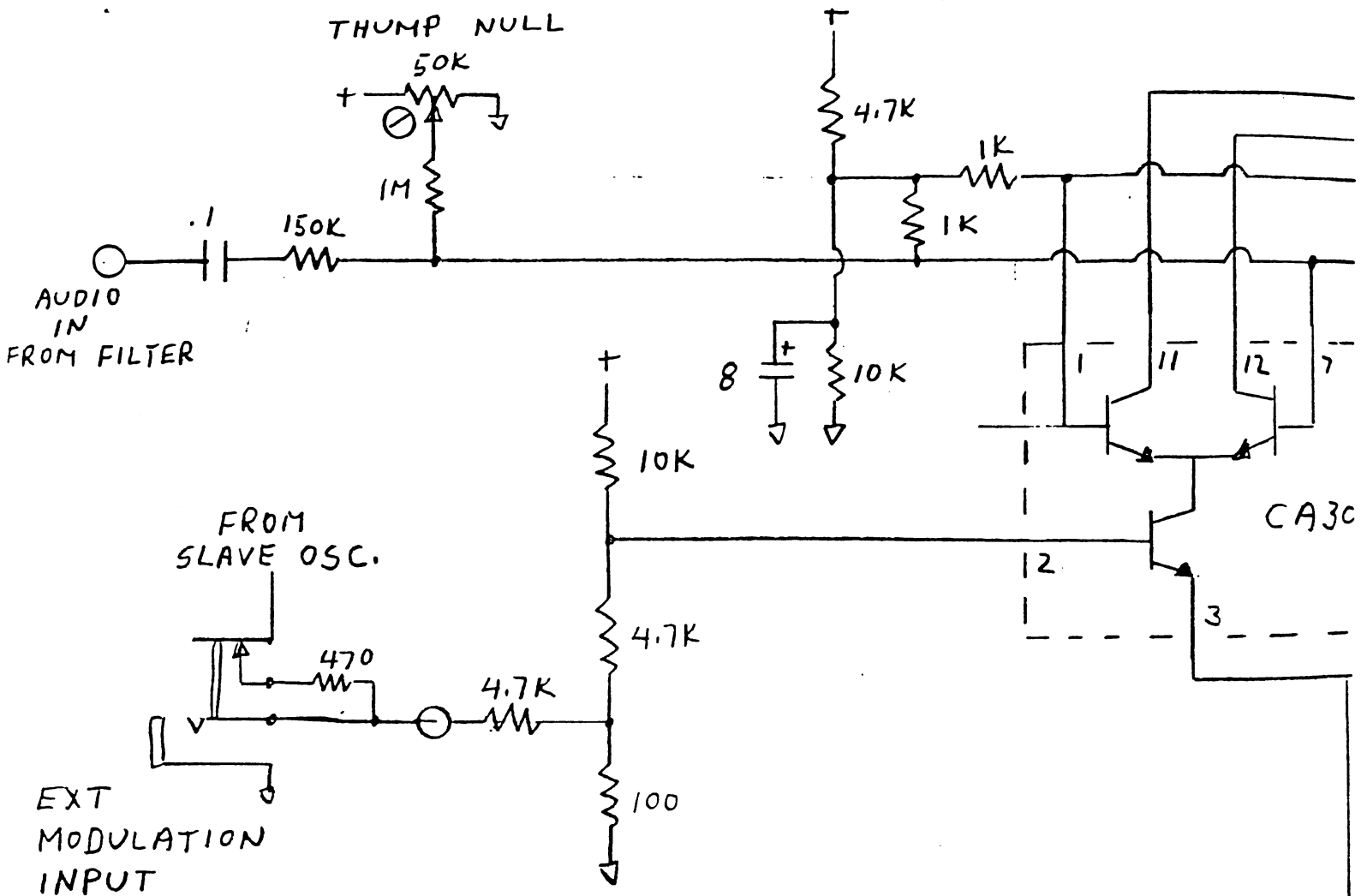

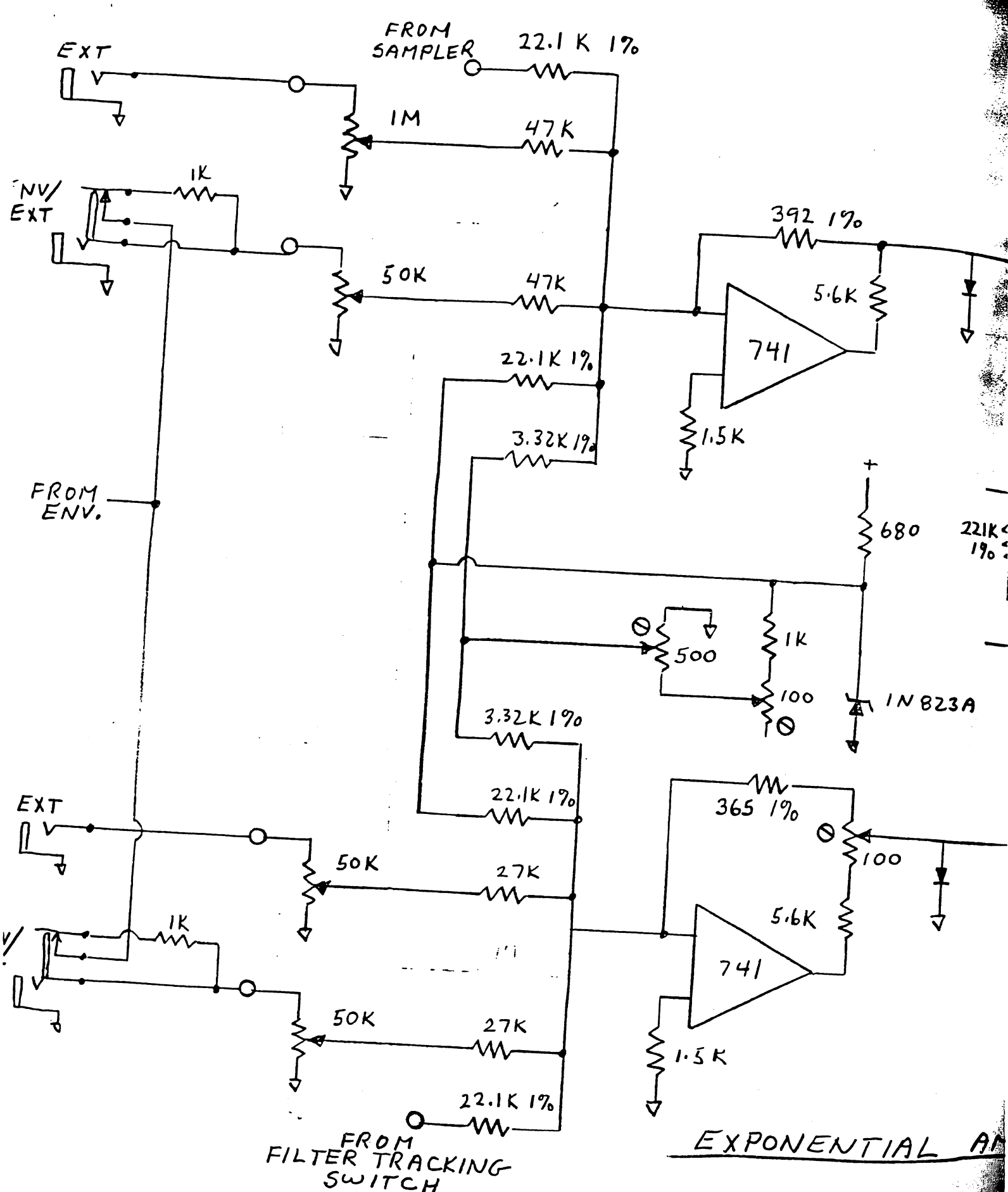

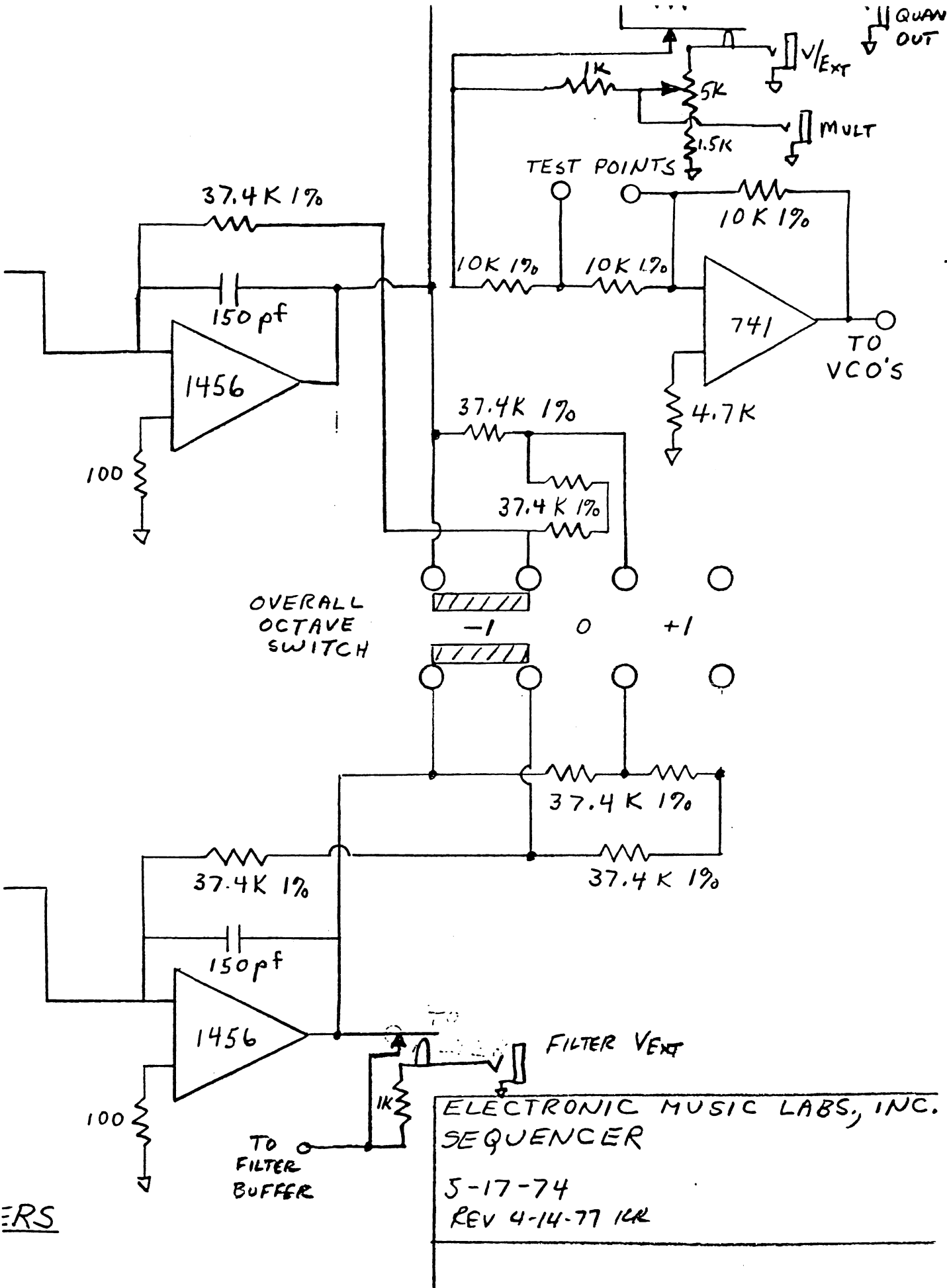

ELECTRONIC MUSIC LABS, INC.
 SEQUENCER
 5-17-74
 REV 4-14-77 ICR

ERS

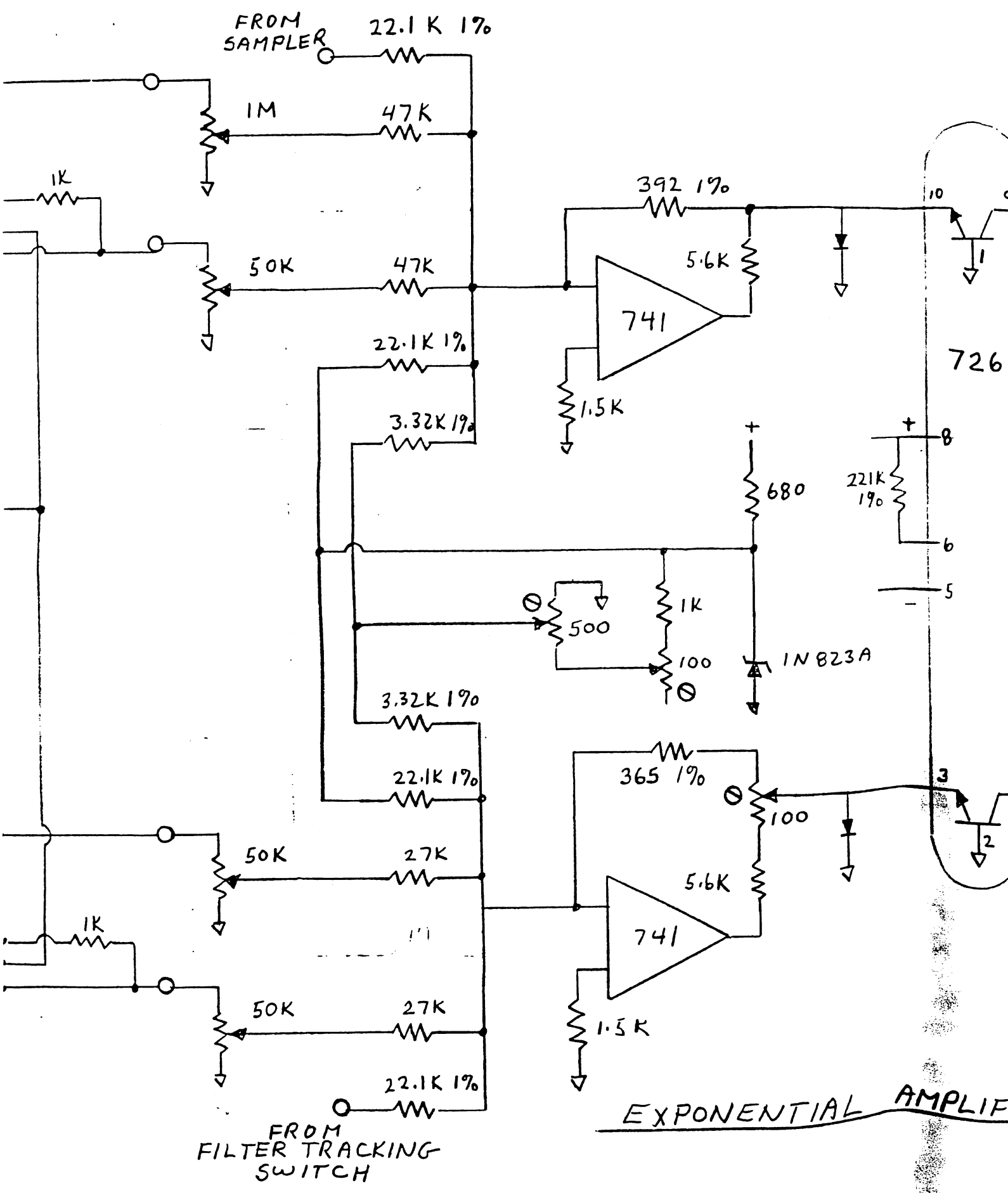

EXPONENTIAL AMPLIF