

# P7000

## Installation & Operation



# Hafler®

# trans•nova▶

DESIGNED AND  
ASSEMBLED IN THE  
**USA**

**PROFESSIONAL POWER AMPLIFIER**

# NOTICE - IMPORTANT SAFETY INFORMATION

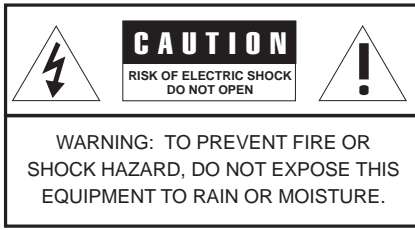

The lightning flash with arrowhead symbol within an equilateral triangle is intended to alert the user to the presence of uninsulated "dangerous voltage" within the product's enclosure, that may be of sufficient magnitude to constitute a risk of electric shock to persons.

The exclamation point within an equilateral triangle is intended to alert the user of the presence of important operating and maintenance (servicing) instructions in the literature accompanying the appliance.

## 1. READ INSTRUCTIONS

All the safety and operating instructions of your Hafler equipment should be read before power is applied to the equipment.

## 2. RETAIN OWNER'S MANUAL

These safety and operating instructions should be retained for future reference.

## 3. HEED WARNINGS

All warnings on the equipment and in the operating instructions are important and should be followed.

## 4. FOLLOW INSTRUCTIONS

All operating and use instructions are important and should be followed.

## 5. HEAT

The equipment should be kept away from areas of high temperature, i.e., heater vents, radiators, stoves/ovens, fireplaces, etc.

## 6. VENTILATION

The equipment should be used in an area suitable for proper ventilation. Care should be taken not to impede airflow in and around the cabinet.

## 7. WATER AND MOISTURE

The equipment should not be used in or around water, such as a bathtub, sink, or swimming area. Also, the equipment should not be used in areas prone to flooding, such as a basement.

## 8. POWER SOURCES

The equipment should be connected only to a power source of the same voltage and frequency as that listed on the rear panel above the power cord entry point.

## 9. POWER CORD PROTECTION

Power cords should be arranged so they do not interfere with the movement of objects in the room: people, fan blades, utility carts, etc. Also, care should be taken that the cord is not pinched or cut, and placed so it is not in danger of being pinched or cut, as in under a rug, around a tight corner, etc.

## 10. POWER CORD GROUNDING

The power supply cord is of a three wire grounded type, designed to reduce the risk of electric shock sustained from a live cabinet. It is assumed to be of suitable length for most uses of the equipment. The use of extension cords and power strips is discouraged unless they are of suitable rating to deliver the required total current for safe operation of all connected equipment. Furthermore, extension cords or power strips must provide

the same three wire grounded connection. It is important that the blades of the equipment's plug be able to fully insert into the mating receptacle. Never remove the round grounding pin on the plug in an attempt to mate to a two wire ungrounded receptacle; use a grounding adaptor with the grounding tab or wire suitably connected to earth ground.

## 11. NON-USE PERIODS

During periods of extended non-use, the power cord should be unplugged from the power source.

## 12. CLEANING

The equipment should be cleaned only as detailed in the operating instructions.

## 13. OBJECT AND LIQUID ENTRY

Care should be taken so that objects and/or liquids, such as cleaning fluids or beverages, are not spilled into the enclosure of the equipment.

## 14. DAMAGE REQUIRING SERVICE

Hafler equipment should be serviced by qualified service personnel when:

A. The power supply cord or plug has been damaged, or

B. Objects have fallen, or liquid has been spilled into the equipment, or

C. The equipment has been exposed to rain, or

D. The equipment does not appear to operate normally or exhibits a marked change in performance, or

E. The equipment has been dropped, or the enclosure has been damaged.

## 15. SERVICING

The user should not attempt to service the equipment beyond that which is described in the operating instructions. All other service should be referred to qualified service personnel.

## 16. CARTS AND STANDS

The equipment should be used with carts or stands only of sufficient strength and stability for the use intended.

An equipment and cart combination should be moved with care. Quick stops and starts, excessive force, and uneven surfaces may cause the equipment and cart combination to topple.

# PERFORMANCE SPECIFICATIONS

## P7000

Power Rating:	FTC (20Hz-20kHz, <0.1% THD)	EIA (1kHz, 0.1% THD)
	350 wpc into 8 $\Omega$	375 wpc into 8 $\Omega$
	500 wpc into 4 $\Omega$ *	525 wpc into 4 $\Omega$ *
	1000 wpc into 8 $\Omega$ *	1050 wpc into 8 $\Omega$ *
	*Continuous sine wave power limited by current rating of line fuse.	
Signal-to-Noise:	100dB below rated output from 20Hz to 20kHz	
Frequency Response:	$\pm$ 0.1dB, 20Hz to 20kHz +0/-3dB, 0.2Hz to 100kHz	
Slew Rate:	100 V/ $\mu$ s	
Input Impedance:	47,000 $\Omega$ per phase	
Input Sensitivity Range for rated output power:	Unbalanced: 1.7V-9.5V RMS (8 $\Omega$ ), 1.4V-8V RMS (4 $\Omega$ ) Balanced: 0.85V-4.75 RMS (8 $\Omega$ ), 0.7V-4V RMS (4 $\Omega$ )	
Gain:	+15dB min. / +30 max.	
CMRR:	-75dB at 1kHz	
Damping Factor:	600 (to 1kHz); 200 (to 10kHz); 25 (to 100kHz)	
Power Consumption:	275 VA quiescent. 1440 VA with both channels driven at 350 watts at 8 $\Omega$ , 1800 VA maximum.	
Controls & Switches:	Front Panel: Power switch, Normal/Bridged mode switch, level controls Rear Panel: Chassis/Float ground switch, Stereo/Bi-amp selector switch	
Crossover:	Variable high-pass, low-pass and bandpass; 100Hz as supplied	
Indicators:	Power lamp, Clip, Short, Thermal, Signal LEDs	
Connectors:	Input: 2-way XLR and 1/4" Tip Ring Sleeve Output: 5-way binding posts spaced for dual banana plugs Power: IEC 320	
Dimensions:	19"W x 12 $\frac{7}{8}$ "D x 3 $\frac{1}{2}$ "H plus 1 $\frac{1}{8}$ " for handles, includes rear supports (48.3cm x 32.7cm x 8.3cm plus 2.875cm for handles, includes rear supports)	
Net Weight:	40 lbs. (18.18kg)	

# TABLE OF CONTENTS

<b>SAFETY PRECAUTIONS</b> .....	i
<b>PERFORMANCE SPECIFICATIONS</b> .....	ii
<b>INTRODUCTION</b> .....	1
<b>INSTALLATION</b>	
Location .....	2
AC Line .....	2
Input .....	2
Input Crossover .....	3
Input Mode Switches .....	3
Output Connections .....	3
<b>OPERATION</b>	
Power Switch .....	4
Level Controls .....	4
XCard Crossovers .....	4
Ground Switch .....	5
Short Circuit Protection .....	5
LED Indicators .....	5
Warm Up .....	5
Cleaning and Maintenance .....	5
<b>TECHNICAL REFERENCE</b>	
Field Service Considerations .....	6
Theory and Operation of trans•nova .....	6
PC Board Layout .....	7
Schematic Diagram .....	8
Parts List .....	10
P7000 Functional Block Diagram .....	12
Circuit Operation .....	13
Amplifier Module Replacement .....	16
Building Custom XCards .....	17
Resistor Chart .....	18
<b>WARRANTY</b> .....	19

# INTRODUCTION

The Hafler P7000 is a two channel professional power amplifier suitable for use in any sound reinforcement situation where faithful, accurate reproduction is required. The amplifier uses forced air fan cooling to deliver high power output in a compact size. Status indicators on the front panel give a visual representation of amplifier and system operation. Input configuration switching and active crossovers enhance the flexibility when used in multiple amp systems, without requiring the use of additional equipment. The use of our patented *trans•nova* circuit topology and MOSFET output stage ensures reliable, long term operation which is backed by our five year warranty.

This manual contains information on using the P7000 amplifiers. It is organized into three main sections. “**Installation**” covers the location and connection of the amplifier in the system. Like many precision components, careful attention to the initial setup can yield dividends in higher performance and trouble-free use. “**Operation**” covers the controls and features of the amplifiers and how to use them to get the best effect. The “**Technical Reference**” section contains field service information; in addition to the schematic and parts list there are block diagrams and circuit operation explanations useful for technicians. We strongly urge reading over the Installation and Operation portions of this manual before putting the amplifier into service.

The circuitry used in the Hafler Professional power amplifiers is our *trans•nova* (TRANSconductance NOdal Voltage Amplifier, US Patent 4,467,288) circuit. The P7000 also utilizes our proprietary DIABLO (Dynamically Invariant **AB** Linear Operation, patent application in progress) transconductance driver stage which combines the linearity of Class A operation with the current headroom of a Class B system. When combined with the robust output stage used in the P7000, DIABLO yields lower high frequency distortion without the sonic penalties associated with increasing the negative feedback. We have been using MOSFETs in our power amplifiers since the 1970s. During this time, they proved to be extremely fault tolerant, even in abusive situations. This ruggedness enables the amplifier to drive reactive speaker loads without the performance and sound penalties imposed by elaborate Safe Operating Area protection schemes.

Active crossovers are incorporated at the input of the amplifier. These crossovers are controlled through the use of our XCard plug-in modules. Each XCard can operate as a full-range, high-pass or low-pass filter with a 12dB per octave Butterworth alignment. Each channel utilizes two XCards which in combination can be configured as a 24dB per octave slope or a 12dB per octave bandpass filter. Since the XCard contains the resistors and capacitors that establish the crossover Q and frequency; specific system requirements can easily be accommodated just by changing the component values.

Input configuration switches allow the amplifier to be configured for conventional stereo, two channel mono or single channel bridged use. When the amplifier is run in two-channel mono mode, the level controls and crossovers for each channel are fully functional which allows for using the amplifier as a single channel in a bi-amped system.

Specialized circuits which prevent damage to the amplifiers and speakers have been carefully implemented to avoid affecting the audio signal. A soft start circuit prevents sending potentially destructive turn-on and turn-off transients to the speakers. A thermal sensing network monitors the heatsink temperature and shuts down the amplifier to protect it from excessive operating heat. The need for internal fuses has been eliminated; a sensing circuit monitors the output and shuts down the power when it detects a short in the output load.

Each channel of the amplifier has been built as a self-contained module. This modular arrangement simplifies construction and improves service accessibility. The circuit board assembly makes extensive use of surface mount components in the low power portion of the audio circuitry. Automated equipment is used to place and solder the components which yields greater uniformity and reliability.

The front panel has controls for input level adjustment and the power switch. In addition, LED indicators give a visual representation of the operating status of each channel. The THERMAL and SHORT indicators light to show when these protection circuits have been activated. The clip indicator helps prevent damaging the speakers by showing when the amplifier is overdriven. The SIGNAL indicator lights to show the presence of an audio signal.

# INSTALLATION

## LOCATION

The P7000 uses forced-air fan cooling to remove the heat produced in normal operation. Although this makes the amplifier less sensitive to ventilation than if it were passively cooled, fresh air flow at the mounting location must still be considered. The fan pulls in fresh air through the side vents and the heated air is forced out through the front panel. Another consideration when choosing the location for a fan cooled amplifier is its proximity to the listening position. In some situations the sound of the fan operation can be distracting.

The power transformer can generate a substantial magnetic field, so caution should be exercised in the placement of low level components such as a tape deck, mixer or mic preamp to avoid inducing noise in the low level circuitry. Allow several inches of clearance when mounting these components.

## AC LINE

The P7000 operates from a 120 volt, 60Hz AC power line. Connection is made by 14 gauge, IEC Type 320, grounded line cord. For safety considerations only a properly grounded (earthed) receptacle should be used. If a grounded circuit is not available do not break off the ground pin; use the proper adapter plug for a two wire receptacle. The power line fuse is mounted on the rear panel of the amplifier. If this fuse blows replace it only with the same type and rating fuse. The correct replacement fuse value is printed on the rear of the amplifier and in the parts list.

## INPUT

The input jacks used on the P7000 are dual function connectors which accept 1/4" (Tip Ring Sleeve) phone and XLR plugs. The amplifier will operate with either a balanced or unbalanced signal source. The connector pin-out is printed on the rear panel of the amplifier.

### ***Balanced Input: 1/4" Tip Ring Sleeve***

The 1/4" balanced input jack is connected according to conventional usage with the Tip high (+), Ring return (-) and the Sleeve ground shield.

### ***Balanced Input: XLR***

The XLR balanced input jack is connected according to the IEC and AES Standard, with pin 2 high (+), pin 3 return (-) and pin 1 ground shield. When preparing to use the amplifier, check the output configuration of the source unit to maintain the proper signal polarity.

### ***Unbalanced Input***

Many popular mixers use unbalanced RCA phono or 1/4" phone jacks for the monitor outputs and can be used with the P7000 for short cable runs. The specifications for the mixer should give the maximum cable length it is capable of driving. The return (-) terminal must be grounded when using the amplifier with the input unbalanced to prevent unstable operation.

### ***Unbalanced Source with Balanced Input***

Some systems will have a noticeable amount of residual ground noise when run with unbalanced signal lines. Better noise rejection can be achieved in these systems by using shielded, twisted pair (balanced) cable from the unbalanced source. At the source end of the cable, connect an RCA or 1/4" phone plug with the return (-) wire and shield connected to the ground terminal of the plug. Wire the plug at the amplifier end of the cable the same as for the regular balanced input connection described above.

## INPUT CROSSOVER

The XCard crossover modules are plug-in cards located inside the amplifier. The P7000 is shipped with 100Hz XCards in each channel. Since each XCard can operate full range, high-pass or low-pass, with a 12dB per octave slope, this allows the amplifier to be used in a wide range of applications. XCards are available for a variety of frequencies from your dealer or through our Customer Service department.

To order additional XCards call Customer Service at 800-669-9899. Office hours are 8:00 a.m. to 5:00 p.m. MST, Monday through Friday. All orders are pre-paid and VISA and MasterCard are accepted.

## INPUT MODE SWITCHES

### *Two-Channel Stereo*

To run the P7000 in two-channel mode, set the front channel NORMAL/BRIDGED switch in the NORMAL position and set the rear panel STEREO/BI-AMP switch to the STEREO position. This configures the amplifier for conventional left and right stereo operation.

### *Dual Mono*

The rear panel STEREO/BI-AMP switch configures the input connection required by the amplifier. With the switch set for STEREO Channel 1 and Channel 2 require separate input signal source feeds. When the switch is set for BI-AMP the Channel 1 input feeds the signal to both amplifier channels for dual-mono operation. The level control and XCard for each channel are still active.

### *Bridged Mono*

In systems with higher power requirements, the P7000 can be configured for signal channel, bridged mono operation. To bridge the amplifier, set the front panel NORMAL/BRIDGED switch to the BRIDGED position. Only the Channel 1 input and level control is used and the Channel 2 level control and XCard are not active. The speaker is connected to the RED output binding posts. When the amplifier is bridged, the output is floating. Any speaker which requires a common ground from the amplifier output cannot be used in this application. Since a bridged amplifier shares the load between the two channels, each channel will effectively drive half of the load. Therefore, for bridged operation we recommend using an eight ohm load as the minimum impedance.

## OUTPUT CONNECTIONS

The speaker output connectors are dual binding posts which will accept wire up to 12 AWG. They are spaced on 3/4" centers for use with dual banana plugs.

# OPERATION

## POWER SWITCH

The POWER switch is located on the front panel of the amplifier. An internal lamp indicates when it is turned on. Standard practice is to turn the amplifier on last and off first when switching components individually to prevent sending damaging transients, generated in the source components, to the speakers. It is possible to leave the power switch in the on position and switch the amplifier remotely through a power distribution block or preamp switched outlet. When doing so make sure the switch is rated for the current required by the amplifier.

## LEVEL CONTROLS

The input sensitivity, for each channel, can be adjusted individually using the level controls on the front panel. The gain control on an amplifier is usually fully advanced to its maximum (rated) sensitivity. In public systems where it is necessary to match levels, the knobs can be removed and the controls adjusted with your fingers or a flathead screwdriver. Cover the holes with the enclosed plugs to restrict access.

## INPUT CONFIGURATION SWITCHES

### *Stereo/Bi-Amp*

The rear panel STEREO/BI-AMP switch controls the signal routing in the amplifier. In the STEREO position, the signal is supplied independently to Channel 1 and Channel 2. In the BI-AMP position, the signal is fed to both amplifier channels from the Channel 1 input, while retaining full use of the level controls and XCard crossovers. This allows the amplifier to be used in dual-mono or bi-amp systems without requiring auxiliary equipment.

### *Normal/Bridged*

The amplifier operates in two-channel mode when the front panel NORMAL/BRIDGED switch is in the NORMAL position and the rear channel switch is set for STEREO. To use the amplifier in single channel, bridged mono applications, the front panel switch must be in the BRIDGED position. When the switch is set in the BRIDGED position, the Channel 1 (+) and (-) inputs are connected to Channel 2 in reversed polarity, which inverts the Channel 2 output. Only the Channel 1 input is used, and the speaker is connected to the two RED binding posts. The amplifier gain is adjusted by the Channel 1 level control; the Channel 2 control is not active. Because of thermal considerations we do not recommend using less than a nominal eight ohm load on the amplifier when running it in mono.

## XCARD CROSSOVERS

The XCard modules contain the resistors and capacitors which control the frequency at which the card operates. The orientation of the card in the socket determines the operating mode of the crossover. The XCard is labeled to indicate the function of each face. The full range face is marked with a double arrow to show that both edges operate full range. The other face operates as either high-pass or low-pass and an arrow is printed by the function to indicate which edge to insert into the socket.

Each amplifier channel uses two XCards. When both cards are set full range, the full frequency response of the amplifier is used. When one card is set full range and the other for either high-pass or low-pass, the signal is crossed over at 12dB per octave with a Butterworth alignment at the frequency determined by the card which is used. When both cards are set for the same operation, whether it is high-pass or low-pass, the signal is crossed over at a 24dB per octave slope. When one card is set for low-pass and the other for high-pass, a bandpass crossover limits the signal to the frequency range determined by the cards which are used. The slope of the filter is 12dB per octave. There is no effect on the bandpass operation regardless of which of the cards is used for the high-pass or low-pass function.

Assembled XCards are available at a variety of operating frequencies. Since there will be situations which the stock cards will not satisfy, instructions for building XCards for specific applications have been included in the **Technical Reference** section of this manual.



## **GROUND SWITCH**

Ground loops are characterized by a hum or buzz through the speakers and are caused by a voltage potential difference between two points in a ground circuit. Ground loops are aggravated when multiple paths exist for a given circuit. Mounting components in a rack with metal rails may introduce ground loops between associated equipment, because the rails can establish an additional ground path. The CHASSIS/FLOAT switch allows you to select the amplifier grounding scheme for best system compatibility. With the switch in the CHASSIS position all signal grounds are referred to the chassis and power line ground. In the FLOAT position the signal ground is decoupled from the chassis. The position of the switch is determined by the overall noise in the system; choose the position which gives the lowest hum.

## **SHORT CIRCUIT PROTECTION**

The self-protecting properties of the output power MOSFETs eliminates the need for sonically degrading voltage and current limiting circuits. To protect the amplifier from problems which may occur in the speaker line, there is an overload detection circuit. In the event of a short in the speaker load or cables, the detection circuit will shut down that channel and light the front panel SHORT indicator. If this happens, correct the fault and turn the amplifier off, then back on to reset the short detector.

## **LED INDICATORS**

Amplifier operation is monitored internally and each channel has four status LEDs. These indicators can be used for system troubleshooting in case of aberrant behavior.

### ***Signal***

Monitors the amplifier output and lights when a signal is present. The SIGNAL indicator is calibrated to activate an equivalent input voltage of 30mV, with the amplifier set for full gain.

### ***Clipping***

Monitors the DRIVE SIGNAL and lights when the drive signal voltage exceeds the maximum level for linear operation of the output MOSFETs.

### ***Thermal***

Indicates when the thermal protection has shut down the amplifier. This occurs when the heatsink temperature becomes excessive.

### ***Short***

Indicates when the output overload monitor detects a potentially damaging short and shuts down power to the shorted channel. After clearing the fault, restore normal operation by turning the power switch off, then on again.

## **WARM UP**

In order to achieve the best sonic performance and image stability from the amplifier, we recommend letting it warm up for 1 hour before beginning any critical listening.

## **CLEANING AND MAINTENANCE**

There is no requirement for regular maintenance on the electronic components of the amplifier. If the case becomes soiled it can be cleaned using a soft cloth and a mild detergent, such as spray window or glass cleaner. If the amplifier is located in a particularly dusty environment cleaning the inside with compressed air or vacuuming every 18 to 24 months is sufficient.

# TECHNICAL REFERENCE

## FIELD SERVICE CONSIDERATIONS

A primary focus during the design and development of the P7000 was to ensure the dependability of the amplifiers. The use of lateral MOSFET output transistors and the low voltage trans•nova input stage combined with careful component selection for the circuit assembly made the reliability goals achievable. However, a parallel effort was also undertaken to make sure any down time caused by an amplifier fault was minimized by making the amplifier technician “friendly.” The modular construction allows exchanging the entire operational portion of either channel quickly and easily without the need for soldering or specialized equipment.

This section of the manual contains descriptions of circuit operation and block diagrams to assist technicians with component level repairs.

## THEORY AND OPERATION OF trans•nova

The **trans•nova** (**TRANS**conductance **N**odal **V**oltage **A**mplifier) principle is based on our 1984 U.S. Patent 4,467,288. This patent describes the advantages of audio power amplifiers in which a MOSFET output stage is connected in a grounded source configuration. In this connection the output stage has its full voltage gain of typically 20dB (ten times), instead of the usual 1dB loss of voltage follower designs. The output stage is further refined into a trans-impedance stage (current-to-voltage converter), to achieve extremely short loop (fast) negative feedback. The output stage is driven cooperatively by a transconductance stage (voltage-to-current converter).

Using the output stage to supply voltage gain inherently increases the power gain (for the same bandwidth) of the output stage by typically ten times over the conventional follower connection, using the same MOSFET devices. This increase in efficiency allows the use of a much simpler input section than in the more common high voltage designs. The number of serial stages, from input to output can be reduced from five or more to only three. This also allows the input section to be designed with the criteria of high quality Class A line amp with the characteristic high linearity and wide bandwidth.

The disadvantage of the Class A driver stage is the limited current headroom available. A conventional Class A transconductance stage has a 2:1 or 6dB limit on peak-to-quiescent current. The number of MOSFETs used in the P7000 imposes a significant capacitive load on the driver stage, enough of a load to strain the ability of the driver to deliver the required current at the high audio frequencies.

Since the operation of the transconductance driver stage is a major factor in the reproduction quality of the amplifier, we developed our proprietary **DIABLO** (**D**ynamically **I**nvariant **A-B** **L**inear **O**peration, patent application in process) circuit to satisfy the current headroom requirements. **DIABLO** does this by smoothly and continuously varying the current transfer ratios of the two transconductance paths, under the control of the signal current itself. This implementation allows the current transfer ratio of one path to be smoothly and continuously reduced to zero while the other path is smoothly and continuously increased by a factor of two. This yields an additional 14dB of current headroom to drive the MOSFETs. The result is a dramatic reduction in high frequency distortion, combined with improved ultrasonic stability.

The P7000 has the highest power rating of any amplifier utilizing the basic trans•nova principle. Designers of systems with high power requirements can now take advantage of the natural and realistic reproduction characteristic of the trans•nova circuit topology.

# PC BOARD LAYOUT

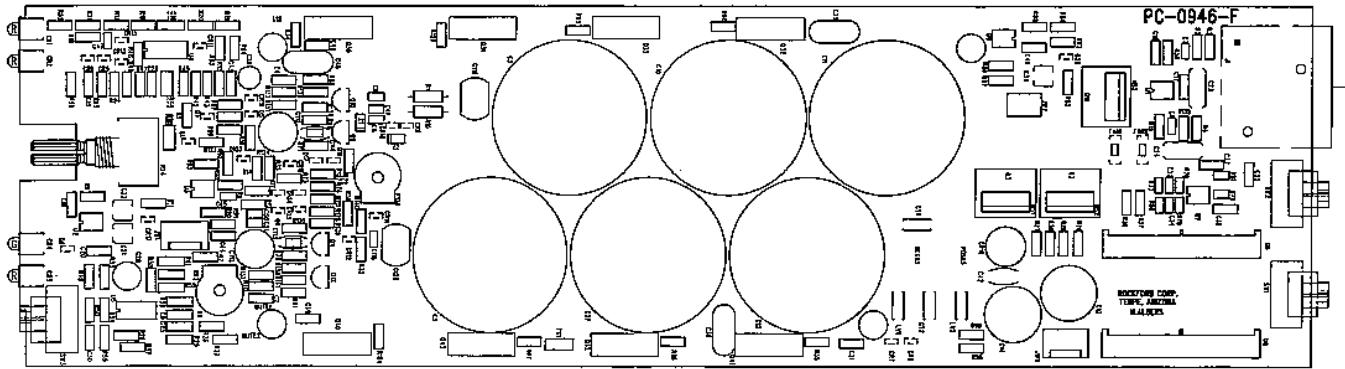

# SCHEMATIC DIAGRAM

- NOTES: Unless specified otherwise  
 1. All resistors in ohms  
 2. Channel 1 only shown.

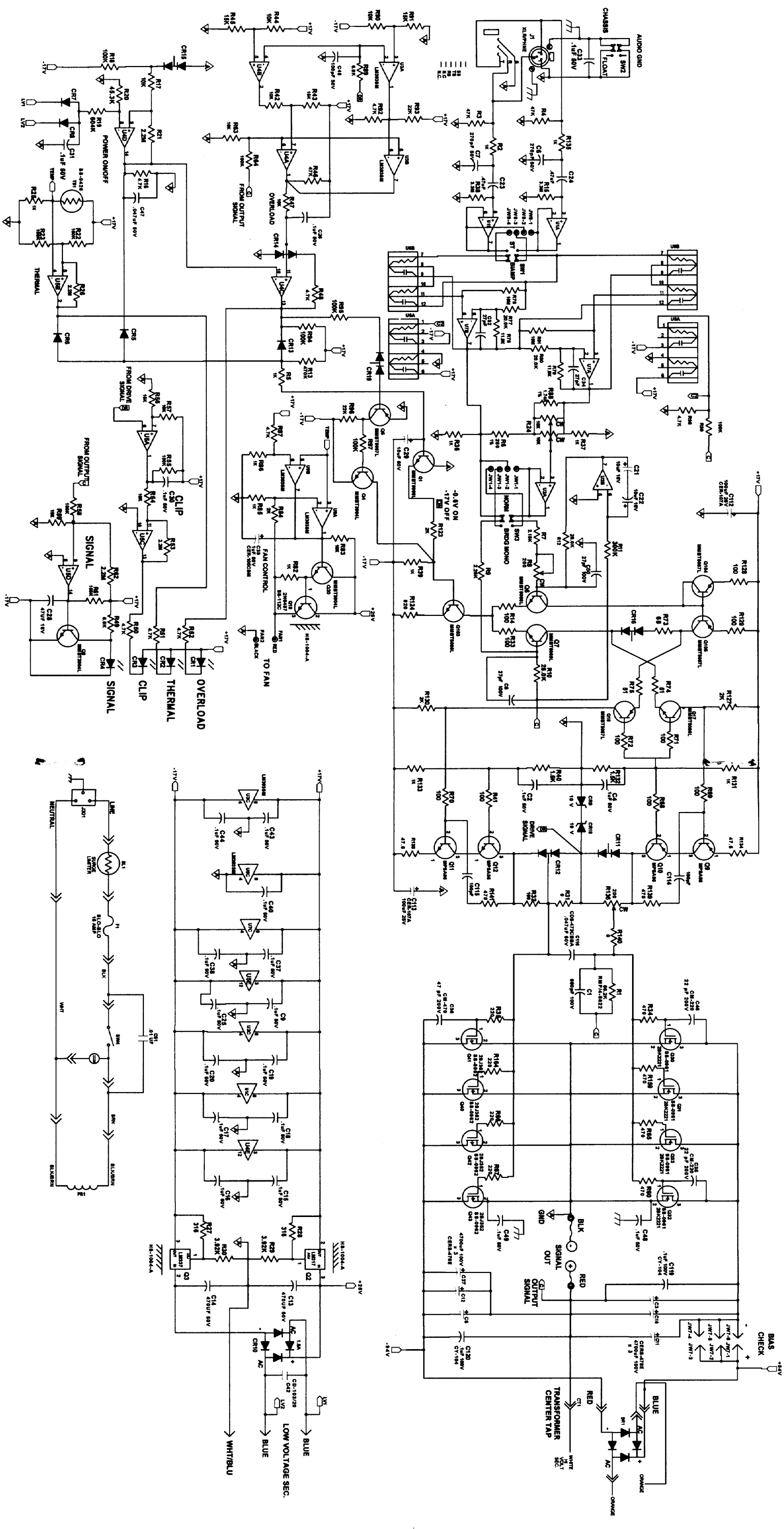

# PARTS LIST

DESIGNATOR VALUE  
ALL RESISTORS IN OHMS

R1 56.2k, 1/4W, 1%  
R2 1k, 1/4W, 5%  
R3 47k, 1/4W, 5%  
R4 47k, 1/4W, 5%  
R5 1k, 1/4W, 5%  
R6 280, 1/4W, 1%  
R7 2.15k, 1/4W, 1%  
R8 200 Trim Pot  
R9 2.26k, 1/4W, 1%  
R10 28k, 1/4W, 1%  
R11 300k, 1/4W, 5%  
R12 28k, 1/4W, 1%  
R13 470k, 1/4W, 5%  
R14 100, 1/4W, 5%  
R15 3.3M, 1/4W, 5%  
R16 4.7k, 1/4W, 5%  
R17 10k, 1/4W, 5%  
R18 100k, 1/4W, 5%  
R19 604k, 1/4W, 1%  
R20 45.3k, 1/4W, 1%  
R21 2.2M, 1/4W, 5%  
R22 100k, 1/4W, 5%  
R23 100k, 1/4W, 5%  
R24 10k Pot, Dual  
R25 1k, 1/4W, 5%  
R26 2.2M, 1/4W, 5%  
R27 316, 1/4W, 1%  
R28 316, 1/4W, 1%  
R29 3.92k, 1/4W, 1%  
R30 3.92k, 1/4W, 1%  
R31 0, 1/4W, 1%  
R32 100, 1/4W, 5%  
R33 100, 1/4W, 5%  
R34 475, 1/4W, 1%  
R35 220, 1/4W, 5%  
R36 1k, 1/4W, 5%  
R37 1k, 1/4W, 5%  
R38 3.3M, 1/4W, 5%  
R39 1k, 1/4W, 5%  
R40 1.5k, 1/4W, 5%  
R41 100, 1/4W, 5%  
R42 10k, 1/4W, 5%  
R43 15k, 1/4W, 5%  
R44 10k, 1/4W, 5%  
R45 15k, 1/4W, 5%  
R46 47k, 1/4W, 5%  
R47 10k, 1/4W, 5%  
R48 4.7k, 1/4W, 5%  
R49 6.8k, 1/4W, 5%  
R50 4.7k, 1/4W, 5%  
R51 4.7k, 1/4W, 5%  
R52 4.7k, 1/4W, 5%  
R53 2.2M, 1/4W, 5%  
R54 10k, 1/4W, 5%  
R55 100k, 1/4W, 5%  
R56 15k, 1/4W, 5%  
R57 10k, 1/4W, 5%  
R58 100k, 1/4W, 5%  
R59 10k, 1/4W, 5%  
R60 475, 1/4W, 1%  
R61 100k, 1/4W, 5%  
R62 2.2M, 1/4W, 5%  
R63 10k, 1/4W, 5%  
R64 100k, 1/4W, 5%  
R65 475, 1/4W, 1%  
R66 220, 1/4W, 5%  
R67 220, 1/4W, 5%  
R68 100, 1/4W, 5%  
R69 100, 1/4W, 5%

PART #

RMP/4 5622-03  
RM/4-102C  
RM/4-473C  
RM/4-473C  
RM/4-102C  
RM/4-2800C  
RM/4-2151C  
RVH-201  
RM/4-2261C  
RMP/4-2802  
RM/4-304C  
RM/4-2802C  
RM/4-474C  
RM/4-101C  
RM/4-335C  
RM/4-472C  
RM/4-103C  
RM/4-104C  
RM/4-6043C  
RM/4-4532C  
RM/4-225C  
RM/4-104C  
RM/4-104C  
RV-0818  
RM/4-102C  
RM/4-225C  
RM/4-3160C  
RM/4-3160C  
RM/4-3921C  
RM/4-3921C  
RM/4-000C  
RM/4-101C  
RM/4-101C  
RM/4-4750C  
RM/4-221C  
RM/4-102C  
RM/4-102C  
RM/4-335C  
RM/4-102C  
RM/4-152C  
RM/4-101C  
RM/4-103C  
RM/4-153C  
RM/4-153C  
RM/4-473C  
RM/4-103C  
RM/4-472C  
RM/4-682C  
RM/4-472C  
RM/4-472C  
RM/4-225C  
RM/4-103C  
RM/4-104C  
RM/4-153C  
RM/4-103C  
RM/4-104C  
RM/4-103C  
RM/4-4750C  
RM/4-104C  
RM/4-225C  
RM/4-103C  
RM/4-104C  
RM/4-4750C  
RM/4-221C  
RM/4-101C  
RM/4-101C

DESIGNATOR VALUE

R70 100, 1/4W, 5%  
R71 100, 1/4W, 5%  
R72 100, 1/4W, 5%  
R73 68, 1/4W  
R74 51, 1/4W, 5%  
R75 51, 1/4W, 5%  
R76 11.8k, 1/10W, 1%  
R77 20k, 1/10W, 1%  
R78 10M, 1/10W, 5%  
R79 11.8k, 1/10W, 1%  
R80 20k, 1/10W, 1%  
R81 10M, 1/10W, 5%  
R82 1k, 1/4W, 5%  
R83 10k, 1/4W, 5%  
R84 2k, 1/4W, 5%  
R85 1k, 1/4W, 5%  
R86 1k, 1/4W, 5%  
R87 4.7k, 1/4W, 5%  
R88 1.74k, 1/4W, 1%  
R89 6.8k, 1/4W, 5%  
R90 10k, 1/4W, 5%  
R91 15k, 1/4W, 5%  
R92 4.7k, 1/4W, 5%  
R93 22k, 1/4W, 5%  
R94 100k, 1/4W, 5%  
R95 100k, 1/4W, 5%  
R96 22k, 1/4W, 5%  
R97 100k, 1/4W, 5%  
R98 4.7k, 1/4W, 5%  
R99 100k, 1/4W, 5%  
R123 2k, 1/4W, 5%  
R124 820, 1/4W, 5%  
R127 2k, 1/4W, 5%  
R128 100, 1/4W, 5%  
R129 100, 1/4W, 5%  
R130 2k, 1/4W, 5%  
R131 1k, 1/4W, 5%  
R132 1.5k, 1/4W, 5%  
R133 1k, 1/4W, 5%  
R134 47.5, 1/4W, 1%  
R135 1k, 1/4W, 5%  
R136 200 Trim Pot  
R138 47.5, 1/4W, 1%  
R139 475, 1/4W, 1%  
R140 0, 1/4W, 1%  
R141 475, 1/4W, 1%  
R159 475, 1/4W, 1%  
R164 220, 1/4W, 5%

PART #

RM/4-101C  
RM/4-101C  
RM/4-101C  
RM/4-680C  
RM/4-510C  
RM/4-510C  
RM/10-1182B  
RM/10-2002B  
RM/10-106B  
RM/10-1182B  
RM/10-2002B  
RM/10-106B  
RM/4-102C  
RM/4-103C  
RM/4-202C  
RM/4-102C  
RM/4-102C  
RM/4-472C  
RM/4-1741C  
RM/4-682C  
RM/4-103C  
RM/4-153C  
RM/4-472C  
RM/4-223C  
RM/4-104C  
RM/4-104C  
RM/4-223C  
RM/4-104C  
RM/4-472C  
RM/4-104C  
RM/4-202C  
RM/4-821C  
RM/4-202C  
RM/4-101C  
RM/4-101C  
RM/4-202C  
RM/4-102C  
RM/4-152C  
RM/4-102C  
RM/4-0475C  
RM/4-102C  
RVH-201  
RM/4-0475C  
RM/4-4750C  
RM/4-000C  
RM/4-4750C  
RM/4-4750C  
RM/4-221C

C1 680pF, 100V  
C2 0.1µF, 50V  
C3 4700µF, 100V, Electrolytic  
C4 0.1µF, 50V  
C5 4700µF, 100V, Electrolytic  
C6 270pF, 50V  
C7 270pF, 50V  
C8 27pF, 100V  
C9 0.1µF, 50V  
C10 4700µF, 100V, Electrolytic  
C11 4700µF, 100V, Electrolytic  
C12 4700µF, 100V, Electrolytic  
C13 470µF, 50V, Electrolytic  
C14 470µF, 50V, Electrolytic  
C15 0.1µF, 50V  
C16 0.1µF, 50V  
C17 0.1µF, 50V  
C18 0.1µF, 50V  
C19 0.1µF, 50V  
C20 0.1µF, 50V

CDS-681DBAA  
CDS-104CCDB  
CERS-478E  
CDS-104CCDB  
CERS-478E  
CDS-271CAAA  
CDS-271CAAA  
CDS-270DAAA  
CDS-104CCDB  
CERS-478E  
CERS-478E  
CERS-478E  
CER-477C-024  
CER-477C-024  
CDS-104CCDB  
CDS-104CCDB  
CDS-104CCDB  
CDS-104CCDB  
CDS-104CCDB  
CDS-104CCDB  
CDS-104CCDB  
CDS-104CCDB

DESIGNATOR	VALUE	PART #	DESIGNATOR	VALUE	PART #
C21	10µF, 16V, Electrolytic	CER-106SM	CR5	MMBD914L Diode	SS-803SM
C22	10µF, 16V, Electrolytic	CER-106SM	CR6	MMBD914L Diode	SS-803SM
C23	0.47µF, 50V	CYV-474-024	CR7	MMBD914L Diode	SS-803SM
C24	0.47µF, 50V	CYV-474-024	CR8	MMBD914L Diode	SS-803SM
C25	0.1µF, 50V	CDS-104CCDB	CR9	MMBZ5240BL 10V Zener Diode	SS-1052
C26	0.1µF, 50V	CDS-104CCDB	CR10	Bridge Rectifier 1.5A	SS-0800
C27	4700µF, 100V, Electrolytic	CERS-478E	CR11	BAV99L Dual Diode	SS-260SM
C28	47µF, 16V, Electrolytic	CER-476-024	CR12	BAV99L Dual Diode	SS-260SM
C29	10µF, 50V, Electrolytic	CER-106C-024	CR13	MMBD914L Diode	SS-803SM
C30	0.1µF, 50V	CDS-104CCDB	CR14	BAV99L Dual Diode	SS-260SM
C31	0.1µF, 50V	CDS-104CCDB	CR15	BAV99L Dual Diode	SS-260SM
C32	27pF, 50V	CDS-270CAAA	CR16	BAV99L Dual Diode	SS-260SM
C33	0.1µF, 50V	CDS-104CCDB	CR18	MMBZ5240BL 10V Zener Diode	SS-1052
C34	27pF, 50V	CDS-270CAAA	CR19	BAV99L Dual Diode	SS-260SM
C35	22pF, 500V, Mica	CM-220-024			
C36	47pF, 500V, Mica	CM-470-024	U1	TL072CD Opamp	SS-143SM
C37	0.1µF, 50V	CDS-104CCDB	U2	TL072CD Opamp	SS-143S
C38	0.1µF, 50V	CDS-104CCDB	U3	LM-393 Dual Comparator	SS-207SM
C39	1.0µF, 50V, Electrolytic	CER-105CSM	U4	LM339 Quad Comparator	SS-730SM
C40	0.1µF, 50V	CDS-104CCDB	U5	LM339 Quad Comparator	SS-730SM
C42	0.01µF, 1kV, Disk	CD-103/20-024	U6	XCard Connector	CC-0233
C43	0.1µF, 50V	CDS-104CCDB	U7	TL072CD Opamp	SS-143SM
C44	0.1µF, 50V	CDS-104CCDB	U8	XCard Connector	CC-0233
C45	100pF, 50V	CDS-101CAAA	U9	LM-393 Dual Comparator	SS-207SM
C46	22pF, 500V, Mica	CM-220-024			
C47	0.047µF, 50V	CDS-473CBBA			
C48	0.1µF, 50V	CDS-104CCDB	J1	Input Jack, Combo	CC-0588
C49	0.1µF, 50V	CDS-104CCDB		Dual Binding Post	CC-0867
C50	27pF, 100V	CDS-270DAAA		Binding Post Back Plate	HW-0908
C112	100µF, 25V, Electrolytic	CER-107A-024		Binding Post Mounting Nut	HW-0905
C113	100µF, 25V, Electrolytic	CER-107A-024	J301	Line Cord Socket	CC-0918
C114	100pF, 50V	CDS-101CAAA		Line Cord 14/3	FA-0209
C115	100pF, 50V	CDS-101CAAA	SL1	Surge Limiter	FA-1000-B
C116	0.047µF, 50V	CDS-473CBBA		Fuse Holder, Cap	FS-0828
C119	0.1µF, 100V, Mylar	CY-104-024		Fuse Holder, Body	FS-0829
C120	0.1µF, 100V, Mylar	CY-104-024		Fuse Holder Washer	FS-0827
				Fan, 80x25mm, 24VDC	FAN-0990
Q1	MMBT5088L	SS-0114		Level Control Cover	HP-0878
Q2	LM-317 + Regulator	SS-239-046		Level Control Knob	KN-0838
Q3	LM-337 – Regulator	SS-240-046		Adhesive Feet	HWH-169
Q4	MMBT3904L	SS-0792	SW1	DPDT Slide Switch	SW-0280
Q5	MMBT5087L	SS-0115	SW2	DPDT Slide Switch	SW-0280
Q6	MMBT5088L	SS-0114	SW3	DPDT Slide Switch	SW-0280
Q7	MMBT5088L	SS-0114	SW4	Power Switch	SWH-152B
Q8	MMBT3904L	SS-0792	F1	Line Fuse, 15A Slo Blo	FS-015SB
Q9	MPS-A56	SS-101A	TS1	Thermistor 10k, NTC	SS-0426-066
Q10	MPS-A56	SS-101A		Transformer	TT-0958-B
Q11	MPS-A06	SS-102A		Rack Handle	HW-1017-A
Q12	MPS-A06	SS-102A		Rack Ears	SM-1016-C
Q17	MMBT5088L	SS-0114			
Q18	MMBT5087L	SS-0115			
Q19	2N-6488	SS-112C-046			
Q20	MMBT3904L	SS-0792			
Q30	N Channel MOSFET	SS-0961-069			
Q31	N Channel MOSFET	SS-0961-069			
Q32	N Channel MOSFET	SS-0961-069			
Q33	N Channel MOSFET	SS-0961-069			
Q40	P Channel MOSFET	SS-0962-069			
Q41	P Channel MOSFET	SS-0962-069			
Q42	P Channel MOSFET	SS-0962-069			
Q43	P Channel MOSFET	SS-0962-069			
Q103	MMBT5088L	SS-0114			
Q104	MMBT5087L	SS-0115			
Q105	MMBT5087L	SS-0115			
BR1	Bridge Rectifier	SSH-609			
CR1	LED Red	SS-741			
CR2	LED Red	SS-741			
CR3	LED Red	SS-741			
CR4	LED Green	SS-740			

# P7000 FUNCTIONAL BLOCK DIAGRAM

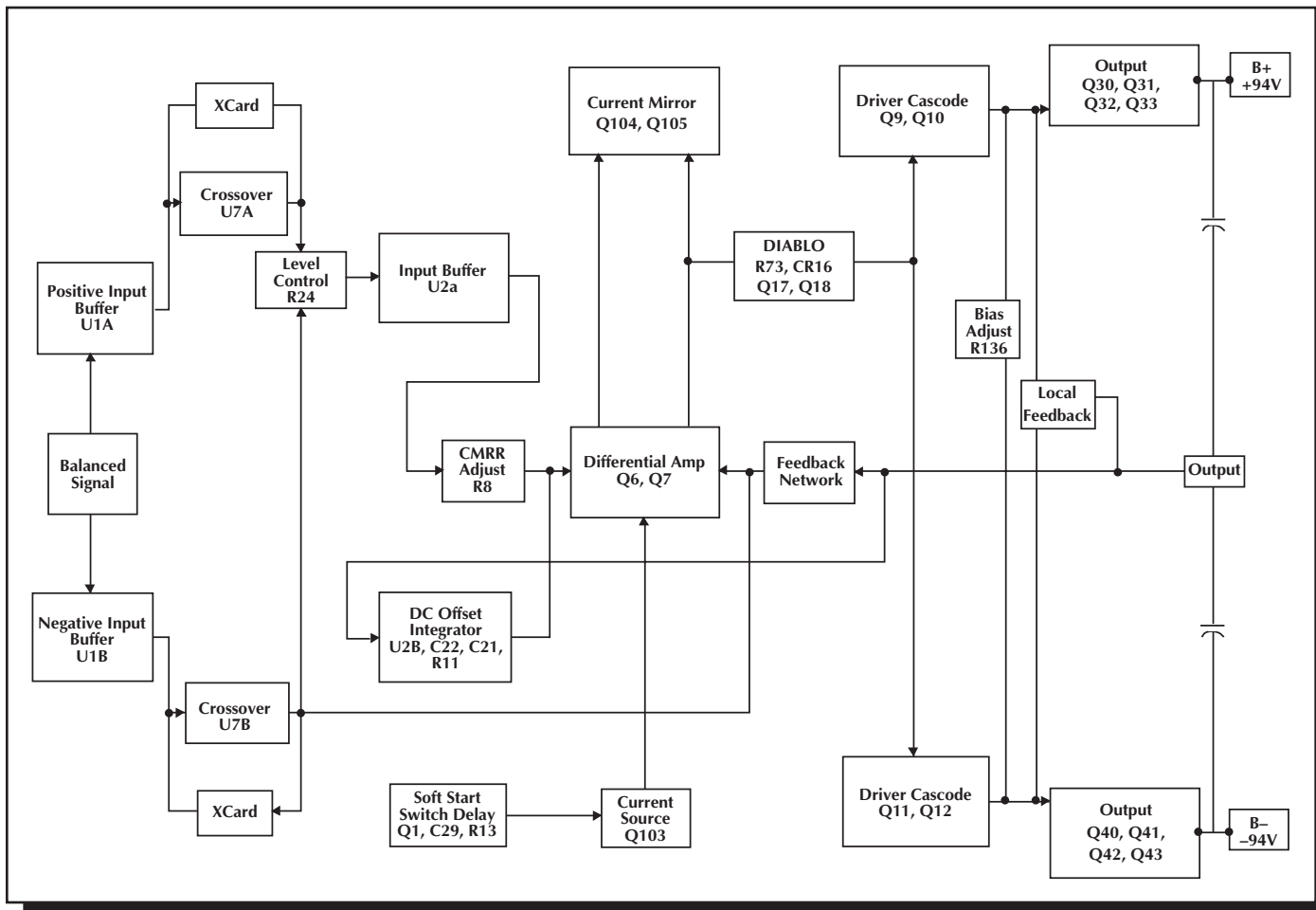

## CIRCUIT OPERATION

### *trans•nova Implementation*

The transistor Q1 is configured to operate as a switch which controls the current source, Q103, of the input differential amp, Q6 and Q7. When Q1 is off the emitter voltage is low turning off Q103. Timing of the Soft Start function is controlled by the charging time of C29 through R13. The THERMAL Protection circuit uses Q1 to shut down the channel when excessive heat is detected. The OVERLOAD protection switch Q5 and Q4 turn off Q3 directly when a short is detected on the output.

U1A and U1B are buffer amps configured as unity gain, non-inverting voltage followers which feed the crossover filters U7A and U7B. The feedback components which control the crossover functions are contained on the XCard plug-in module. The output of the filters is fed to the attenuator network controlled by R24. The output of U2A and U7B is connected to the input of the differential amp. U2B is configured as a DC servo integrator to null the input offset currents.

The output of the differential amp is fed to the driver stage by Q17 and Q18 which perform the DIABLO transconductance steering function. The cascode pairs Q9, Q10 and Q11, Q12 supply the signal voltage and current needed to drive the output stage Q30, Q31, Q32, Q33 and Q40, Q41, Q42, Q43. Class AB bias current is controlled by R136. Loop feedback is supplied by the network R1 and C1, and global feedback by R10, C8 and C41.

### ***Adjusting Bias:***

The bias control establishes the quiescent Class AB output current of the amplifier. The bias should not need readjustment from the factory setting; however, if the amplifier is repaired and output devices have been changed, or if the two channels of the amplifier do not run at the same temperature, recalibrating the bias is necessary. **Disconnect the power to the amplifier before removing the cover.** To adjust the bias, disconnect the input and speakers and remove the jumper JW7. Connect an amp meter across the exposed pins. The correct polarity is marked adjacent to the jumper. Adjust R136 to get a current reading of 400mA.

### ***Calibrating Common Mode Rejection:***

The input common mode null is adjusted by the trim pot R8. The CMRR should be greater than 75dB below rated output. If the CMRR requires adjustment, feed the amplifier input with a common mode signal and adjust R8. **Disconnect the power to the amplifier before removing the cover.** Use a sinewave generator set to 1 volt output at 1kHz. Connect the generator signal output to the tip and ring of a 1/4" plug and ground to the sleeve. Plug this into the amplifier input. Connect an AC voltmeter to the amplifier output binding posts. Adjust R8 to give the lowest voltage output from the amplifier. For a temporary adjustment when a signal generator and voltmeter are not available, use an FM tuner and tune it to an unused station as your signal source, and connect the output to the amplifier as described above. Connect the amplifier output to a small full range speaker. Turn the amplifier level controls full down and turn the amplifier on. Turn up the level control until you hear a signal through the speaker. Alternate between adjusting R8 for the lowest output signal and increasing the input control until you have the level control full. There should be a very low output from the amplifier if any is detected at all.



### Fan Speed Regulation

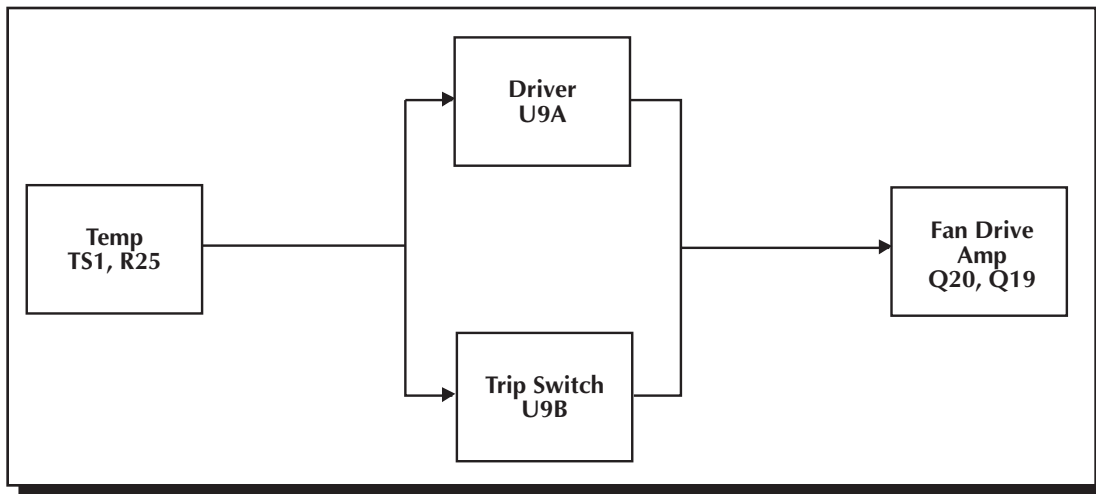

Cooling air for each channel is provided by a DC fan. The fan is configured to track the heatsink temperature, and increases in speed as the amplifier runs hotter. The heatsink temperature, Temp, is determined by the voltage divider TS1 and R25. When the amplifier is turned on the fan will stay off until the Temp voltage exceeds the reference voltage on pin 6 of the Trip Switch U9B and drives the output high to turn on the Fan Drive Amplifier, Q20 and Q19. The Driver U9A is configured as a linear amplifier and controls the output of the Fan Drive Amp to vary the fan speed.

### Output Short Protection

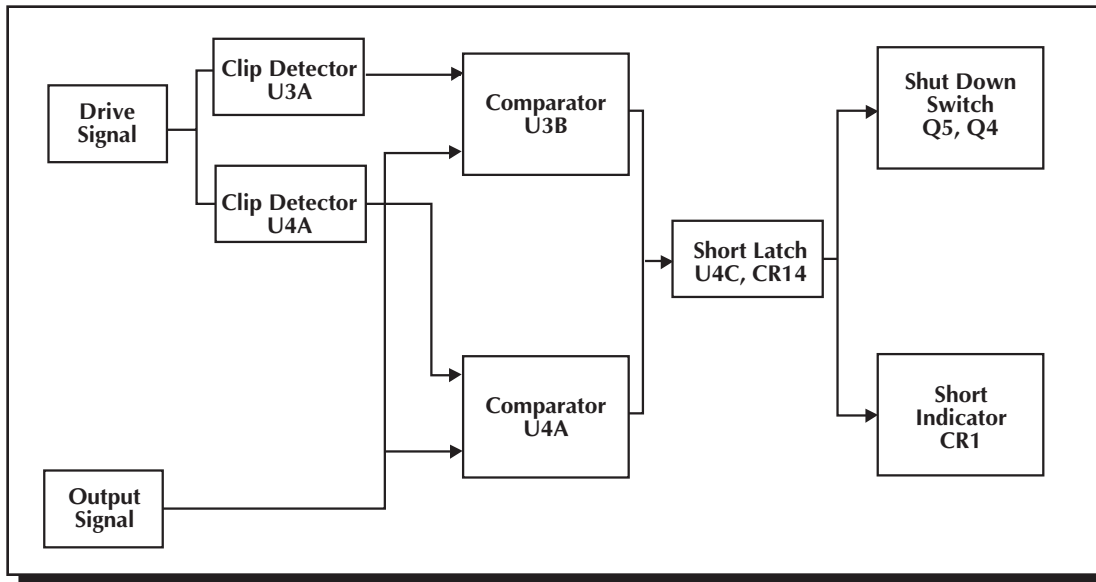

The Short detector monitors the Drive Signal and Output Signal levels and shuts down that channel when a shorted output condition is detected. Recovering from the Short protection requires turning the amplifier off to reset it.

The Clip Detectors U3A and U4B monitor the Drive Signal and change state when the drive signal level is sufficient to clip the output stage. The output of U3A goes high when the drive signal exceeds the clip threshold, and is connected to the input of U3B. If the output signal voltage is not sufficiently positive during a clip event the output of U3B goes low. The output of U4B goes low when the drive signal exceeds the clip threshold, and is connected to the input of U4A. If the output signal voltage is not sufficiently negative during a clip event the output of U4A goes low.

This condition, indicating high drive voltage and low output voltage, can occur only when the output is grounded. If the output of comparator stage U3B or U4A is low for the time sufficient for C26 to charge, then U4C latches low activating the Shut Down Switch Q5 and Q4, and lighting the indicator CR1. The output of U4C is held low by CR14 and will reset only after the power is turned off.

### Thermal Protection

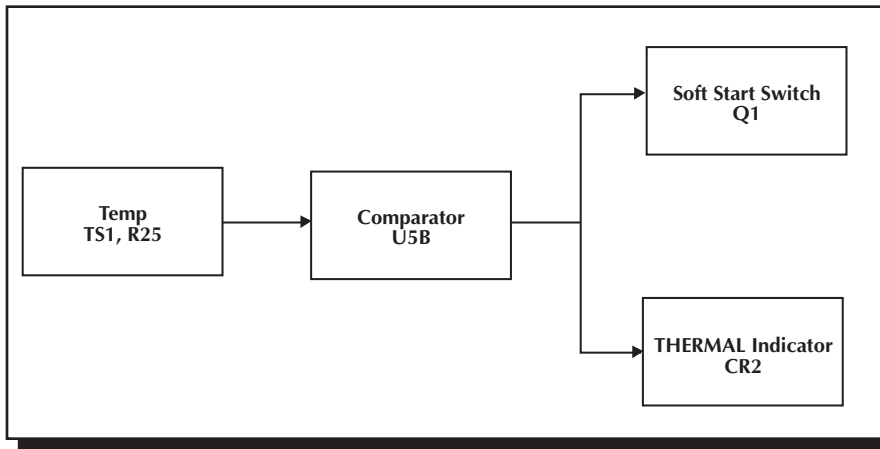

The Thermal protection is activated, and shuts down audio operation, when the amplifier heatsink reaches an excessively high temperature. The voltage divider R22 and R23 establishes the reference voltage on pin 5 of U5B. The control voltage, Temp, on pin 4 is established by the voltage divider TS1 and R25. TS1 is a NTC (Negative Temperature Coefficient) thermistor, mounted on the heatsink. As TS1 warms and the resistance falls, the voltage on pin 4 rises. When the voltage on pin 4 exceeds the voltage on pin 5, the output on pin 2 goes low, shutting down the Soft Start switch Q1 and lighting the THERMAL indicator.

### Clipping Indicator

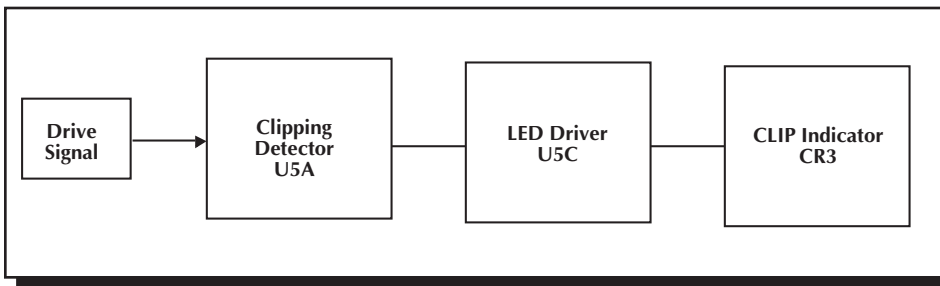

The CLIP indicator is driven by the buffer U5C which is controlled by the comparator U5A. The voltage divider R56 and R57 established the reference voltage for the clipping detector at pin 7 of U5A. The reference voltage scales the output of U5A to indicate when the Drive Signal, at pin 6, demands in excess of the available voltage or current of the output stage. The output of U5A is stretched by R55 and C30 to prevent the CLIP indicator CR3 from flickering. Hysteresis is applied to the LED driver U5C by R53 to stabilize the output during input transitions.

### Signal Present Indicator

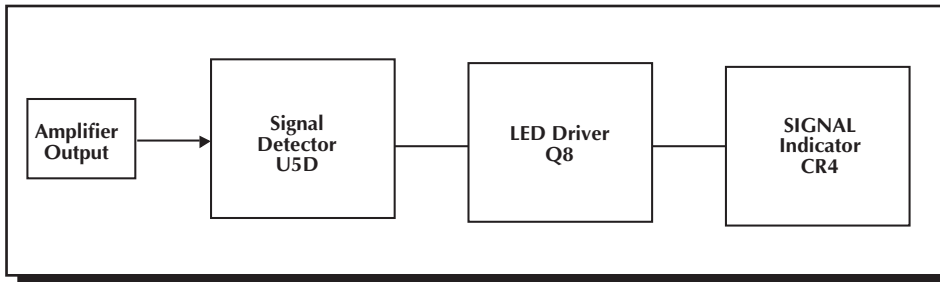

The SIGNAL indicator is controlled by the comparator U5D and the transistor Q8. The amplifier output is connected to the input pin 9. The voltage divider R58 and R59 scales the output voltage to change the comparator output state at an equivalent input voltage of 30mV. The output at pin 14 controls the transistor Q8 to shunt across and turn off the LED CR4.

## AMPLIFIER MODULE REPLACEMENT

The amplifier modules have been designed to eliminate the need for a special workplace if a field exchange becomes necessary. All wire connections are made with quick connect terminals so soldering is not necessary. The following tools are needed to disassemble the amplifier:

Allen wrench, 9/64  
Phillips screwdriver, #1 tip  
Thin nose pliers  
Small cutters

Remove the four Phillips head screws, located on the rear panel, which secure the input jacks. Remove the six 9/64 Allen screws that hold the cover. These are located along the top edge, two on each side and two on the rear. Lift the cover from the rear and remove it. Remove the level control knob. The wire harnesses have been bundled for neatness. Cut the ties to free the bundles.

Disconnect the red and black output wires from the binding posts and the fan and power wires from the amplifier drive card. Disconnect the transformer secondary wires from the bridge rectifier and PC board. Unplug the gray mono cables.

The heatsink is attached to the chassis by three screws, two outside and one inside. Remove the two 9/64 Allen screws on the bottom edge of the side of the amplifier. Remove the Phillips screw located behind the level control, which is accessible through the hole in the PC board. The module can now be lifted from the chassis.

Prepare a new Channel 1 module for installation by setting the input mode switches to the default position according to the markings adjacent to the switches. Prepare a Channel 2 module by duplicating the switch settings of the module which was removed.

Install the new module and check the position and alignment of the indicator LEDs. Replace the level control knob and check the alignment while securing the module.

Plug in the gray mono cables. The headers are marked with the proper position for Channel 1 and Channel 2. The plugs are oriented so the cable will fit properly in one direction only.

Reconnect the remaining wires according to the following chart.

Wire Color	Function	Terminal
Red	Audio Output	Red Binding Post
Black	Output Ground	Black Binding Post
Orange (two)	High Voltage AC	Bridge Rectifier AC
White	High Voltage Center Tap	CT1
Red	High Voltage DC Positive	+ Red
Blue	High Voltage DC Negative	- BLUE
White/Blue	Low Voltage Center Tap	CT2
Blue (two)	Low Voltage AC	LV1, LV2

### BUILDING CUSTOM XCARDS

The XCard crossover control modules used in the P7000 are a versatile and inexpensive method for configuring the amplifier for a wide range of system applications. The XCard eliminates the need for an external crossover or expensive plug-in accessories for multiple amp applications. By having the crossover built into the amplifier input circuit and with the XCard containing all the components controlling the operating frequency, it is very simple to customize to meet system specific requirements. Each amplifier, as supplied, has two 100Hz Butterworth aligned XCards each of which contains two resistors and two capacitors to control the crossover frequency. The XCard will operate as either a high-pass or low-pass filter, depending upon its orientation. The following tools are needed to build the XCards:

Soldering Iron (appropriate for PC board work)

Solder (suitable for electronics)

Desoldering Braid

Our tests have shown that for operating frequencies at 100Hz and lower using 0.047 $\mu$ F capacitors results in more linear crossover control. For frequencies above 100Hz use 0.022 $\mu$ F, the voltage rating should be a minimum of 10V. Use 1/8 or 1/4 watt 1% metal film resistors. Solder the components to the card according to the following diagram.

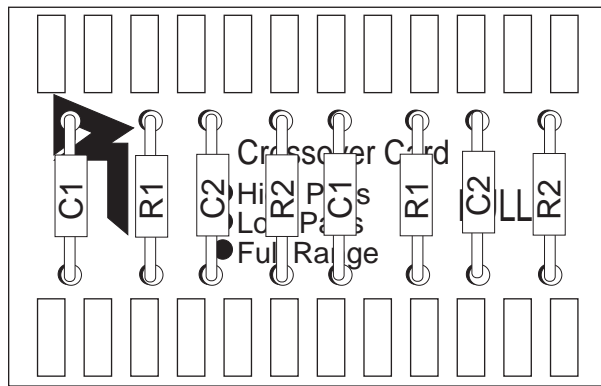

## RESISTOR CHART

The following charts list the resistor values to use for common crossover frequencies.

**Butterworth Alignment Q = .707**  
1% resistors used with 0.047µF capacitors

Frequency	R1	R2
20Hz	169kΩ	169kΩ
25Hz	133kΩ	133kΩ
30Hz	110kΩ	110kΩ
35Hz	95.3kΩ	95.3Ω
40Hz	84.5kΩ	84.5kΩ
45Hz	75kΩ	75kΩ
50Hz	68.1kΩ	68.1kΩ
55Hz	61.9kΩ	61.9kΩ
60Hz	56.2kΩ	56.2kΩ
65Hz	52.3kΩ	52.3kΩ
70Hz	48.7kΩ	48.7kΩ
75Hz	45.3kΩ	45.3kΩ
80Hz	42.2kΩ	42.2kΩ
84Hz	40.2kΩ	40.2kΩ
90Hz	37.4kΩ	37.4kΩ
200Hz	16.9kΩ	16.9kΩ
300Hz	11.3kΩ	11.3kΩ
400Hz	8.45kΩ	8.45kΩ
500Hz	6.65kΩ	6.65kΩ
600Hz	5.62kΩ	5.62kΩ
700Hz	4.75kΩ	4.75kΩ
800Hz	4.22kΩ	4.22kΩ
900Hz	3.74kΩ	3.74kΩ
1kHz	3.40kΩ	3.40kΩ
1.2kHz	2.8kΩ	2.8kΩ
2kHz	1.69kΩ	1.69kΩ
3kHz	1.10kΩ	1.10kΩ
4kHz	845Ω	845Ω
5kHz	665Ω	665Ω
6kHz	562Ω	562Ω
7kHz	487Ω	487Ω
8kHz	422Ω	422Ω

**Butterworth Alignment Q = .707**  
1% resistors used with 0.022µF capacitors

Frequency	R1	R2
20Hz	357kΩ	357kΩ
25Hz	287kΩ	287kΩ
30Hz	237kΩ	237kΩ
35Hz	205kΩ	205kΩ
40Hz	178kΩ	178kΩ
45Hz	162kΩ	162kΩ
50Hz	143kΩ	143kΩ
55Hz	130kΩ	130kΩ
60Hz	121kΩ	121kΩ
65Hz	110kΩ	110kΩ
70Hz	102kΩ	102kΩ
75Hz	95.3kΩ	95.3kΩ
80Hz	90.9kΩ	90.9kΩ
85Hz	84.5kΩ	84.5kΩ
90Hz	80.6kΩ	80.6kΩ
200Hz	35.7kΩ	35.7kΩ
300Hz	23.7kΩ	23.7kΩ
400Hz	17.8kΩ	17.8kΩ
500Hz	14.3kΩ	14.3kΩ
600Hz	12.1kΩ	12.1kΩ
700Hz	10.2kΩ	10.2kΩ
800Hz	9.9kΩ	9.9kΩ
900Hz	8.6kΩ	8.6kΩ
1kHz	7.15kΩ	7.15kΩ
1.2kHz	6.04kΩ	6.04kΩ
2.0kHz	3.57kΩ	3.57kΩ
3.0kHz	2.37kΩ	2.37kΩ
4.0kHz	1.76kΩ	1.76kΩ
5.0kHz	1.43kΩ	1.43kΩ
6.0kHz	1.21kΩ	1.21kΩ
7.0kHz	1.02kΩ	1.02kΩ
8.0kHz	909Ω	909Ω

To calculate the resistor value for a frequency not on the chart use the following:

$$\frac{3386}{f_o} = R \text{ (in k}\Omega\text{) for } .047\mu\text{f cap}$$

$$\frac{7234}{f_o} = R \text{ (in k}\Omega\text{) for } .022\mu\text{f cap}$$

$$\text{The actual formula is: } R = \frac{1}{2\pi f_o c}$$

Where: R = Ω

f<sub>o</sub> = desired crossover frequency

c = capacitor in farads

ex: .047 x 10<sup>-6</sup> for .047mf cap

# SERVICE POLICY AND LIMITED WARRANTY

If you encounter any difficulty or have any question concerning your P7000 Amplifier, please call our Technical Support Department weekdays, 8:00 a.m. to 3:30 p.m., Mountain Standard Time, at 800-743-3526.

Should you have any doubts as to whether the amplifier is malfunctioning and requires service, please call us before sending it in for repair. All units being returned (regardless of warranty status) must receive a Return Authorization (RA) number. In addition, we can offer troubleshooting assistance that may simplify or even eliminate the need for factory service.

The Hafler P7000 Amplifier is warranted to the original owner (non-transferrable) for seven years from the date of purchase, including parts, labor, and return shipping costs within the Continental United States, Alaska, and Hawaii. This warranty applies only to products sold in the United States of America.

For warranties outside the U.S.A., please contact your local agent.

It is the owner's responsibility to pay shipping (preferably United Parcel Service, UPS) to the factory: collect shipments will not be accepted. Units under warranty should be accompanied by a copy of the dated Bill Of Sale. Use the original carton and all packing material, with the RA number clearly marked on the outside of the package. Be sure to include a return address, the RA number, a daytime telephone number, and a brief description of the difficulty, including whether it occurs continuously or intermittently.

This warranty gives you specific legal rights. You may also have other rights which may vary from state to state.



HAFLER PROFESSIONAL

A DIVISION OF

ROCKFORD CORPORATION

546 SOUTH ROCKFORD DRIVE

TEMPE, ARIZONA 85281 U.S.A.

IN U.S.A. (602) 967-3565

IN CANADA, (604) 942-1001

IN EUROPE, FAX (49) 4207-801250

IN JAPAN, FAX (81) 559-79-01265

