

KAWAI

CONTENTS

SX-240

8-VOICE PROGRAMMABLE POLYPHONIC SYNTHESIZER

Service Manual



KAWAI

Kawai Musical Instrument
Manufacturing Co., Ltd.

CONTENTS

P.C.B. LAYOUT	1
PARTS LIST	3
BLOCK DIAGRAM	5
SYN-53 CIRCUIT BLOCK LAYOUT	7
SYN-53 TERMINALS INFORMATION ...	9
SYN-53 CIRCUIT DIAGRAM (1/2)	11
SYN-53 CIRCUIT DIAGRAM (2/2)	13
SYN-54 CIRCUIT BLOCK LAYOUT	15
SYN-54 TERMINALS INFORMATION ...	17
SYN-54 CIRCUIT DIAGRAM (1/2)	19
SYN-54 CIRCUIT DIAGRAM (2/2)	21
SYN-51 TERMINALS INFORMATION ...	23
SYN-51 CIRCUIT DIAGRAM	25
SYN-52 TERMINALS INFORMATION ...	27
SYN-52 CIRCUIT DIAGRAM	29
ST-17 TERMINALS INFORMATION	31
ST-17 CIRCUIT DIAGRAM	33
PS-36-FH-08 TERMINALS INFORMATION	35
PS-36-FH-08 CIRCUIT DIAGRAM	37
JA-07-SYN-55 TERMINALS INFORMATION & CIRCUIT DIAGRAM ..	39
SX-240 CIRCUIT FUNCTION	41
SX-240 ADJUSTMENT	44

LOCK DIAGRAM

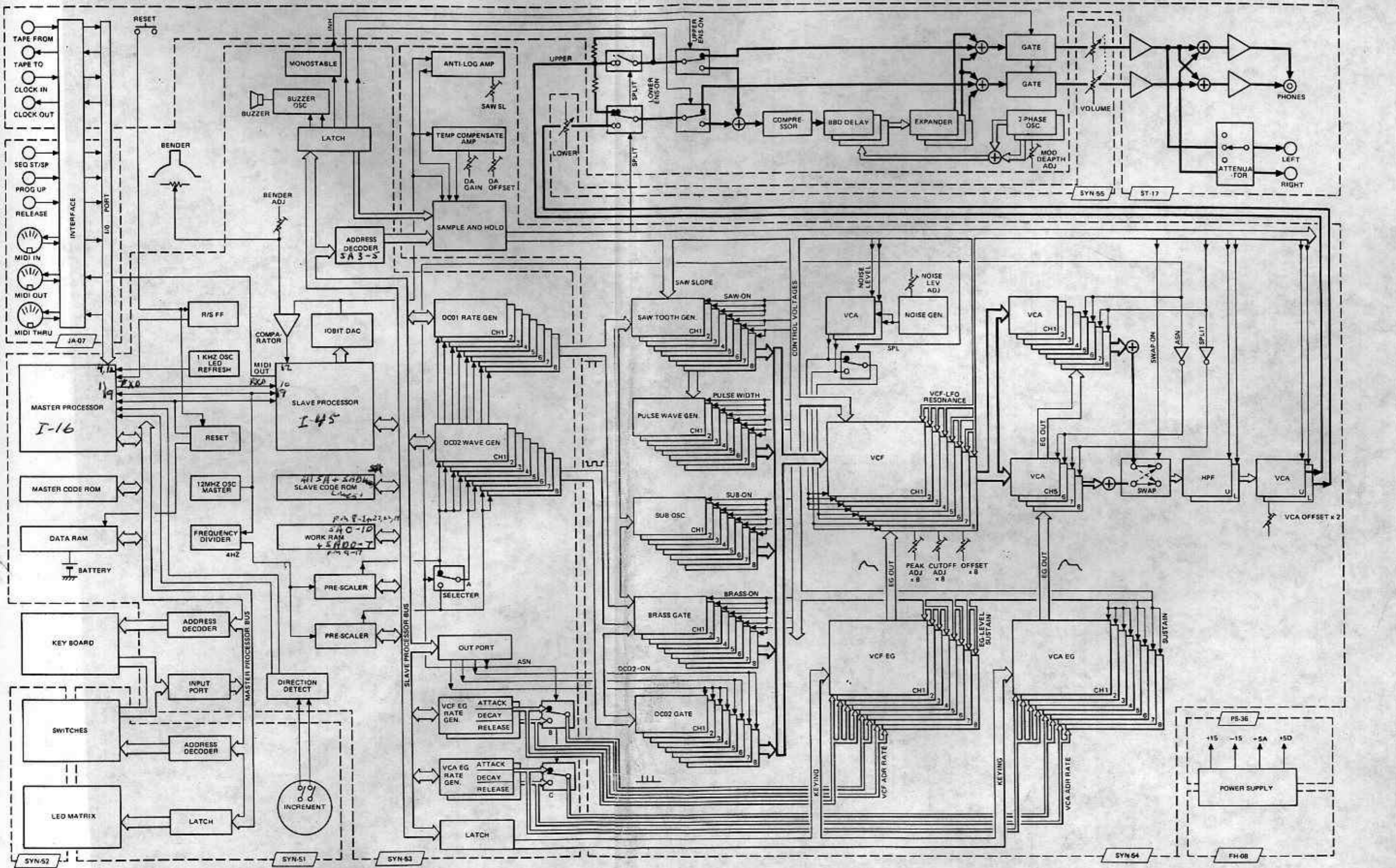

SYN-53 CIRCUIT BLOCK LAYOUT

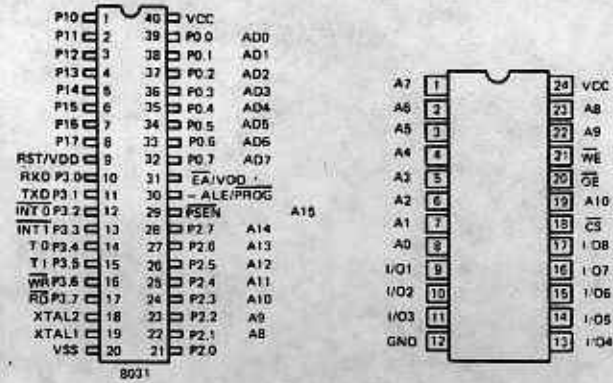

KEYBOARD CIRCUIT DIAGRAM

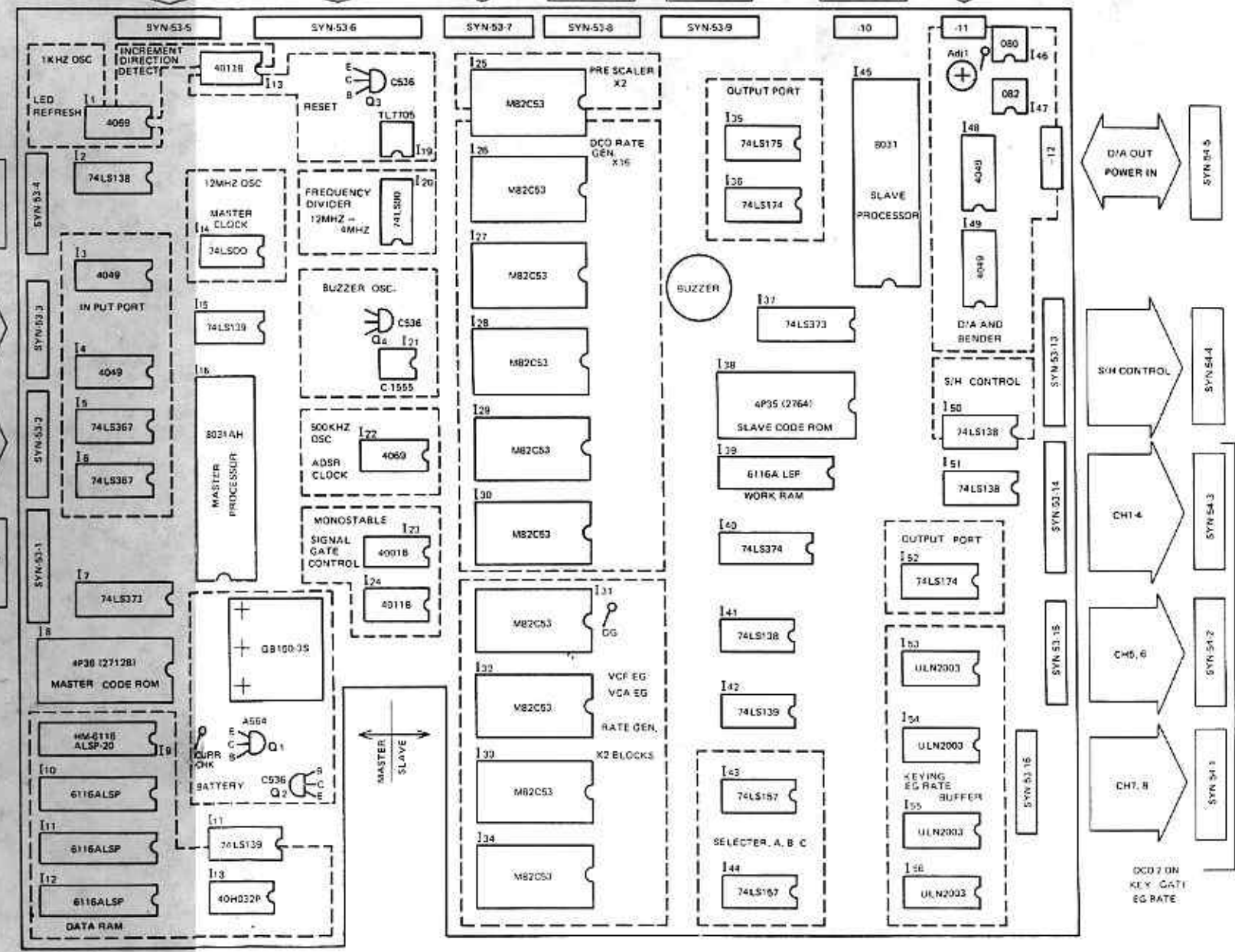
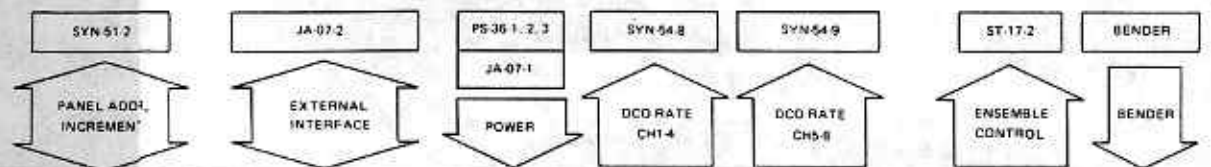
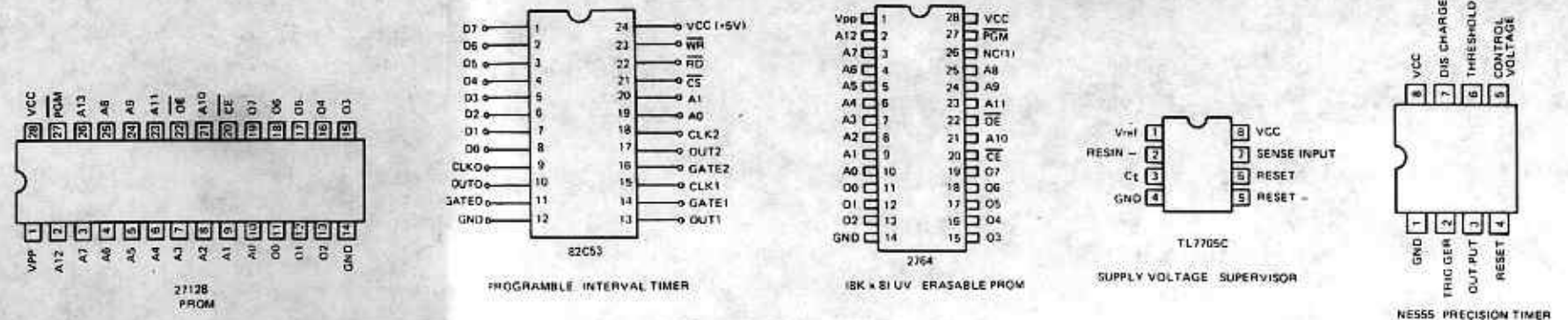
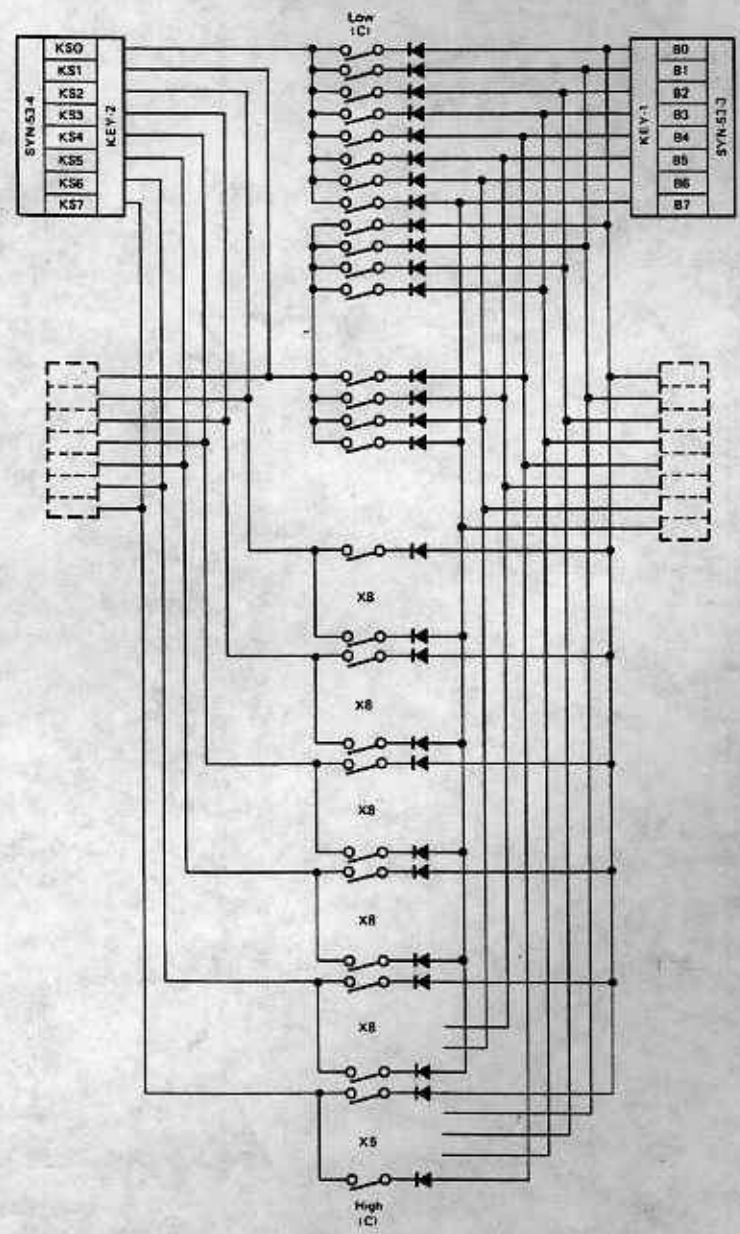

SYN-53 TERMINALS INFORMATION

INFORMATION DAMD

SYN-51-3									
INC1	INC2	DG	MAG	A1	A2	A3	LK1	LK2	FEVA
SYN-53-5									

SYN-53 TERMINALS

JA-07-2									
CASO	DG	CASH	DAMP	PRDG	SEQ	CLKI	CLKO	MIDI	DIOT
MIND	RESET								
SYN-53-6									

DG	+15	PS-36-1
+15	+50	PS-36-2
DG	DG	PS-36-3
INH	ST-17-2	
SYN-53-7		

SYN-54-8					
D11	D12	D21	D22	D31	D32
D41	D42	D61	D62	D71	D72
D81	D82				
SYN-53-8					

SYN-54-9					
D11	D12	D21	D22	D31	D32
D41	D42	D61	D62	D71	D72
D81	D82				
SYN-53-9					

DG	LENS	SYN-55-1
LENS	ST-17-2	
BEND-3	BEND-2	BEND-1
BEND VR		
-11		
SYN-53-10		

KEY-2

K57
K56
K55
K54
K53
K52
K51
K50
SYN-53-4

KEY-1

B7
B6
B5
B4
B3
B2
B1
B0
SYN-53-3

DG
B0
B1
B2
B3
B4
B5
B6
B7
DG
SYN-53-2

DG
AD7
AD6
AD5
AD4
AD3
AD2
AD1
AD0
DG
SYN-53-1

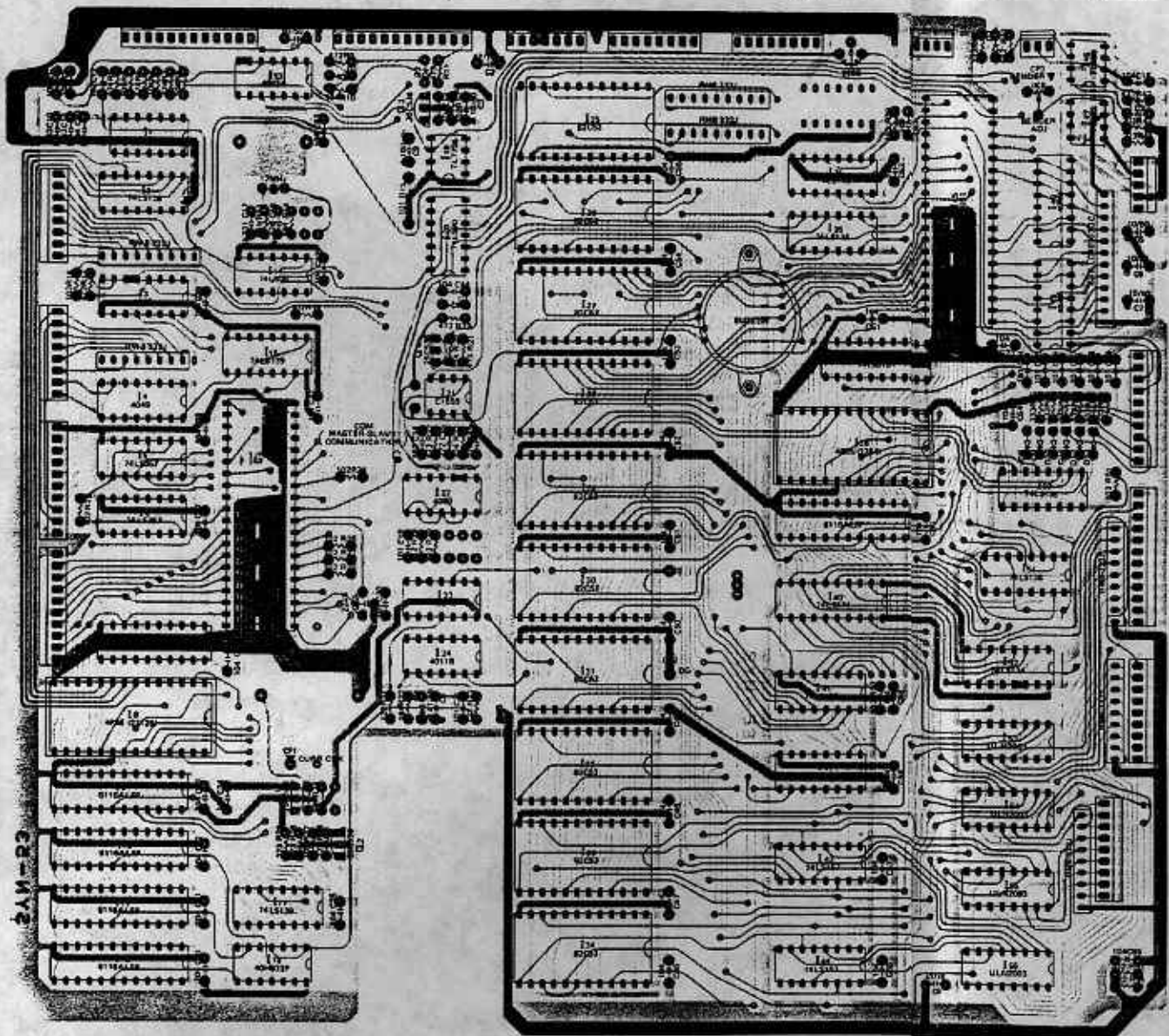

RG
DAC
-15A
+15A
+5A
SYN-54-5

ASN
SHA0
SHA1
SHA2
AS5
AS4
AS3
AS2
AS1
AS0
SYN-54-4

OG1-4
G1
G2
G3
G4
FA1-4
FD1-4
FR1-4
AA1-4
AD1-4
AR1-4
SYN-54-3

OG5-6
G5
G6
FA5-6
FD5-6
FR5-6
AA5-6
AD5-6
AR5-6
SYN-54-2

OG7-8
G7
G8
FA7-8
FD7-8
FR7-8
AA7-8
AD7-8
AR7-8
SYN-54-1

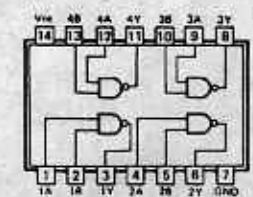

SN74LS00 (J, N)
QUADRUPLE 2-INPUT POSITIVE-NAND GATES

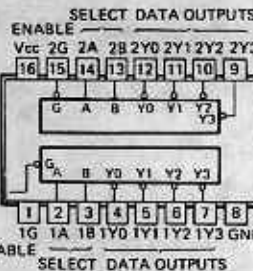

SN74LS139 (J, N)
DUAL 2-TO-4-LINE DECODERS/MULTIPLEXERS

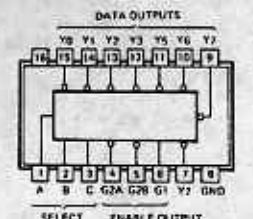

SN74LS138
3-TO-8-LINE DECODERS/MULTIPLEXERS

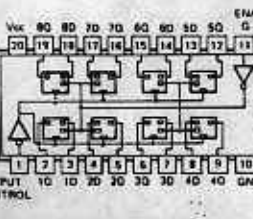

SN74LS373
OCTAL D-TYPE LATCHES

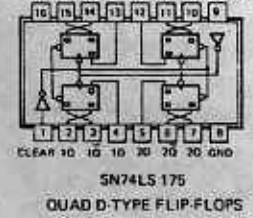

SN74LS175
QUAD D-TYPE FLIP-FLOPS

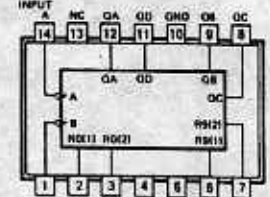

SN74LS90
DECADE COUNTERS

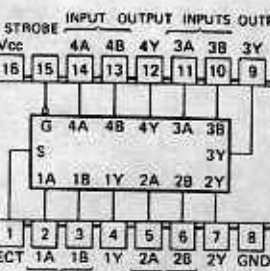

SN74LS157 (J, N)
QUAD 2-TO-1-LINE DATA SELECTORS/MULTIPLEXERS

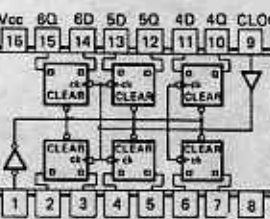

SN74LS174 (J, N)
HEX D-TYPE FLIP-FLOPS

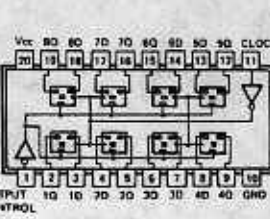

SN74LS374
OCTAL D-TYPE FLIP-FLOPS

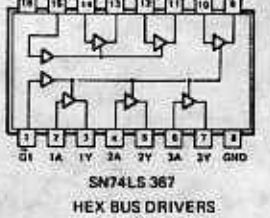

SN74LS367
HEX BUS DRIVERS

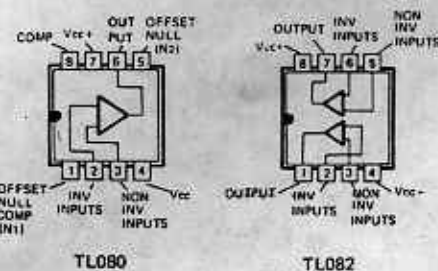

TL080 **TL082**
DARLINGTON TRANSISTOR ARRAYS

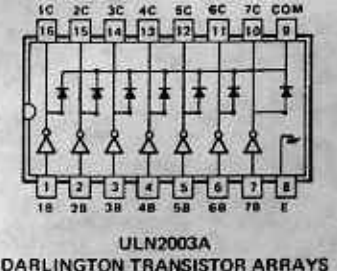

ULN2003A
DARLINGTON TRANSISTOR ARRAYS

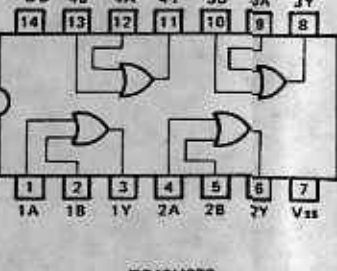

TC40H032
QUAD 2-INPUT OR GATE

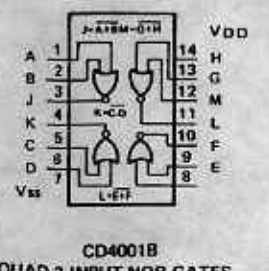

CD4001B
QUAD 2-INPUT NOR GATES

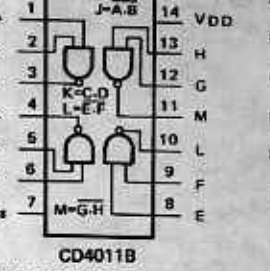

CD4011B
QUAD 2-INPUT NAND GATE



CD4049UB
HEX INVERTING BUFFERS

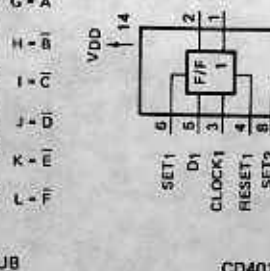

CD4069UB
HEX INVERTER

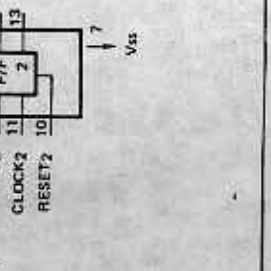

CD4013B
DUAL D-TYPE FLIP-FLOP

■ SYN-53 CIRCUIT DIAGRAM (1/2)

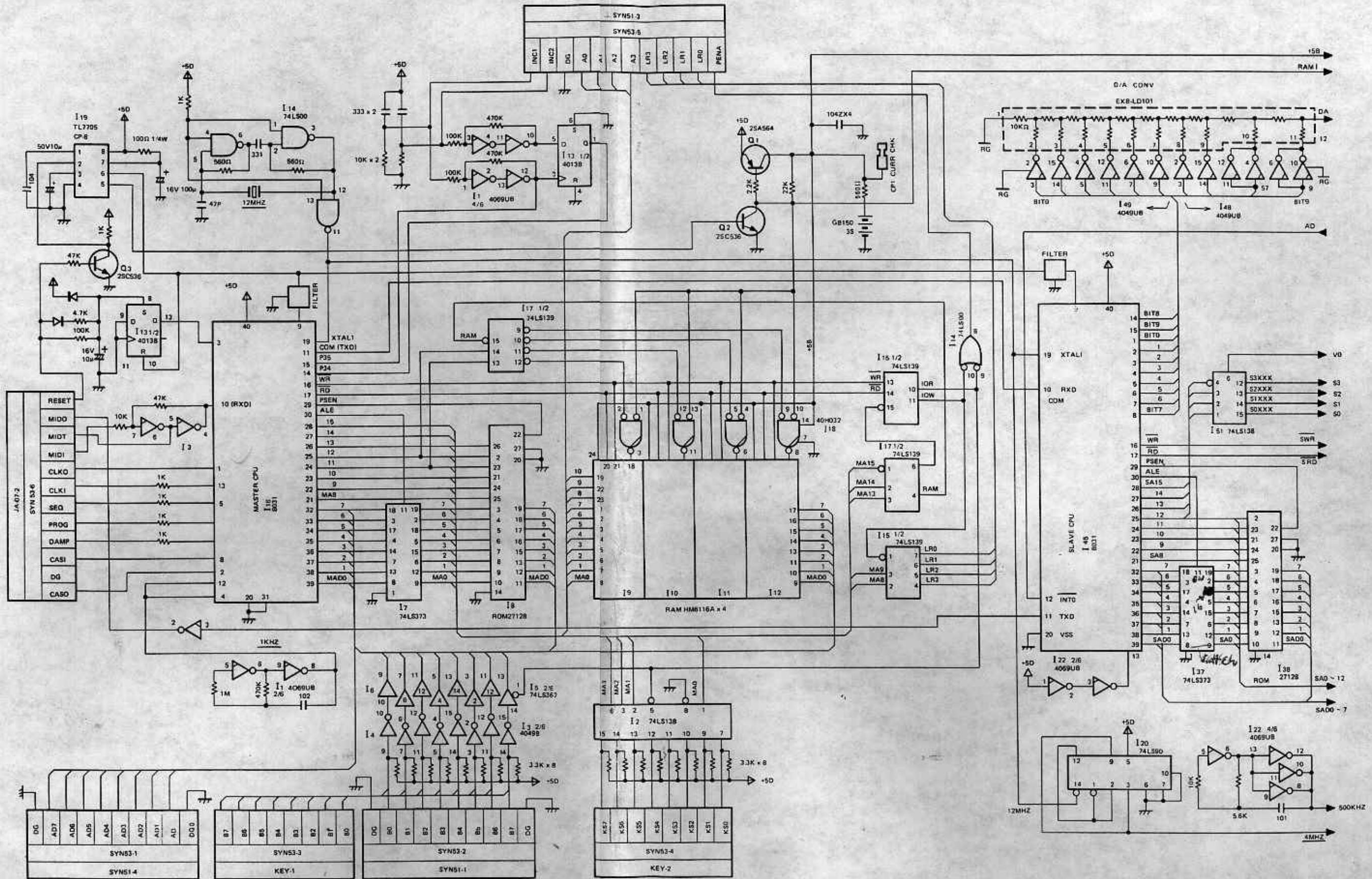

SYN-53 CIRCUIT DIAGRAM (2/2)

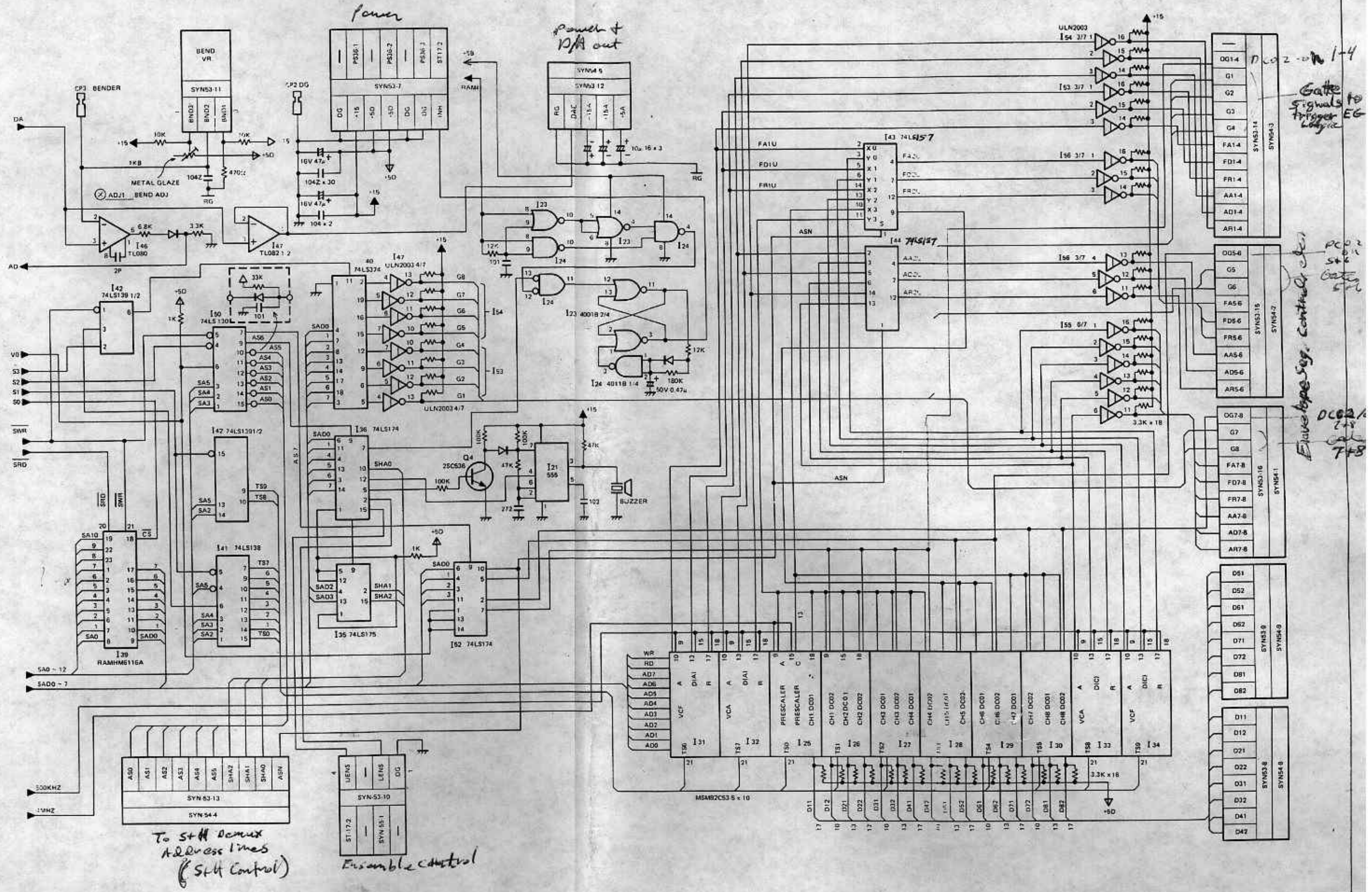

To STM Demux
A & B address lines
(STM Control)

Envelope control

Gate signals to
trigger EG
Logic

Envelope Seg. Control
PC02
2+4
5+6
Gate
5+6

PC02
2+4
5+6
Gate
5+6

SYN-54 CIRCUIT BLOCK LAYOUT

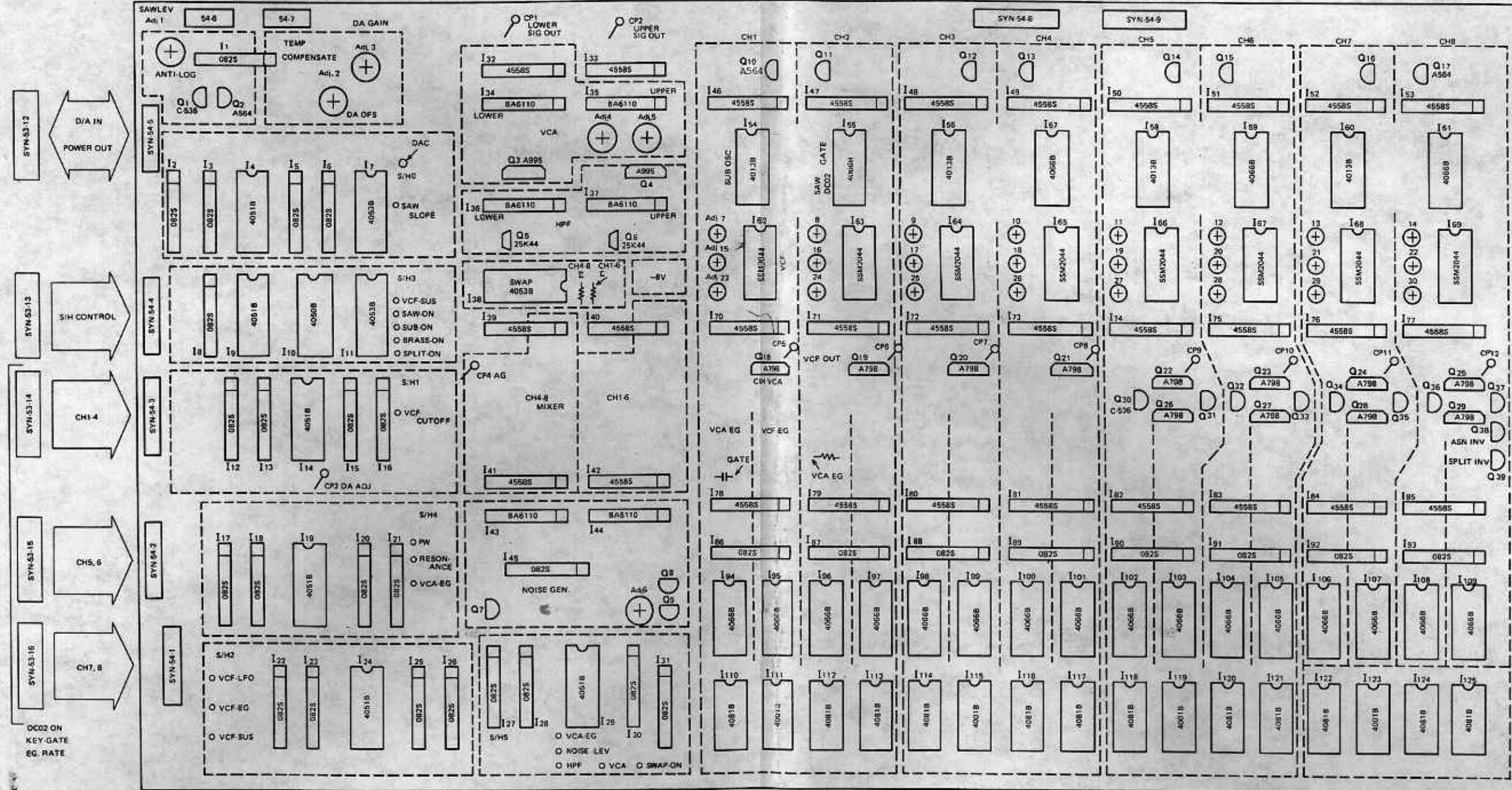
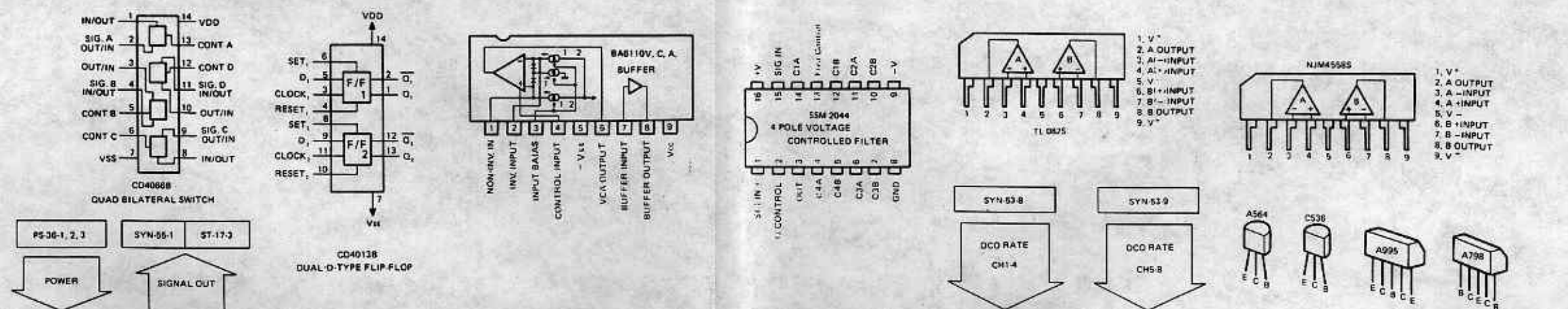

■ SYN-54 TERMINALS INFORMATION

1	RG	PS-36-3
2	.15	PS-36-2
3	AG	PS-36-3
4	+15	PS-36-2
5	+5A	PS-36-1
6	SPLIT	ST-17-2

1	LOUT	SYN 55
2	SHIELD	ROUT
3	ROUT	SHIELD
4	SHIELD	ST-17

SYN-53-8							
D42	D41	D32	D31	D22	D21	D12	D11
SYN-54-8							
1	2	3	4	5	6	7	8

SYN-53-9							
D82	D81	D72	D71	D62	D61	D52	D51
SYN-54-9							
1	2	3	4	5	6	7	8

SYN-53-12		SYN-54-5	
9	RG	4	DAC
8	.15	3	+15
7	+5A	2	+5A

SYN-53-13		SYN-54-4	
10	ASN	10	ASN
9	SHA0	9	SHA0
8	SHA1	8	SHA1
7	SHA2	7	SHA2
6	AS5	6	AS5
5	AS4	5	AS4
4	AS3	4	AS3
3	AS2	3	AS2
2	AS1	2	AS1
1	AS0	1	AS0

SYN-53-14		SYN-54-3	
12	OG1-4	11	OG1-4
11	G1	10	G1
10	G2	9	G2
9	G3	8	G3
8	G4	7	G4
7	FA1-4	6	FA1-4
6	FD1-4	5	FD1-4
5	FR1-4	4	FR1-4
4	AA1-4	3	AA1-4
3	AD1-4	2	AD1-4
2	AR1-4	1	AR1-4

SYN-53-15		SYN-54-2	
9	OG5-6	9	OG5-6
8	G5	8	G5
7	G6	7	G6
6	FA5-6	6	FA5-6
5	FD5-6	5	FD5-6
4	FR5-6	4	FR5-6
3	AA5-6	3	AA5-6
2	AD5-6	2	AD5-6
1	AR5-6	1	AR5-6

SYN-53-16		SYN-54-1	
9	OG7-8	9	OG7-8
8	G7	8	G7
7	G8	7	G8
6	FA7-8	6	FA7-8
5	FD7-8	5	FD7-8
4	FR7-8	4	FR7-8
3	AA7-8	3	AA7-8
2	AD7-8	2	AD7-8
1	AR7-8	1	AR7-8

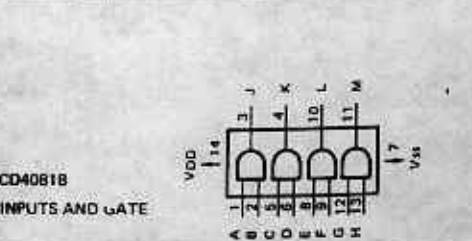
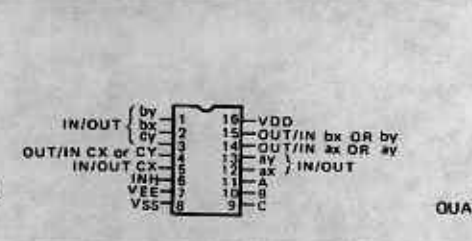
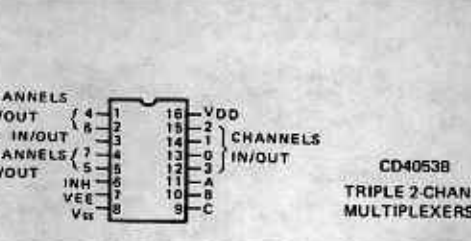
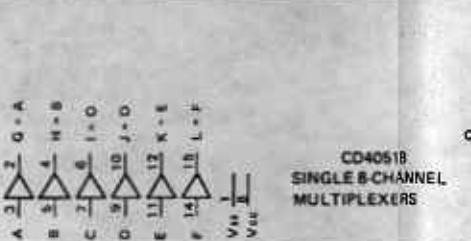
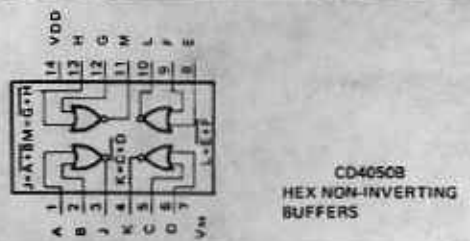
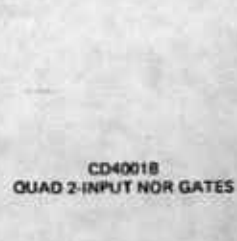
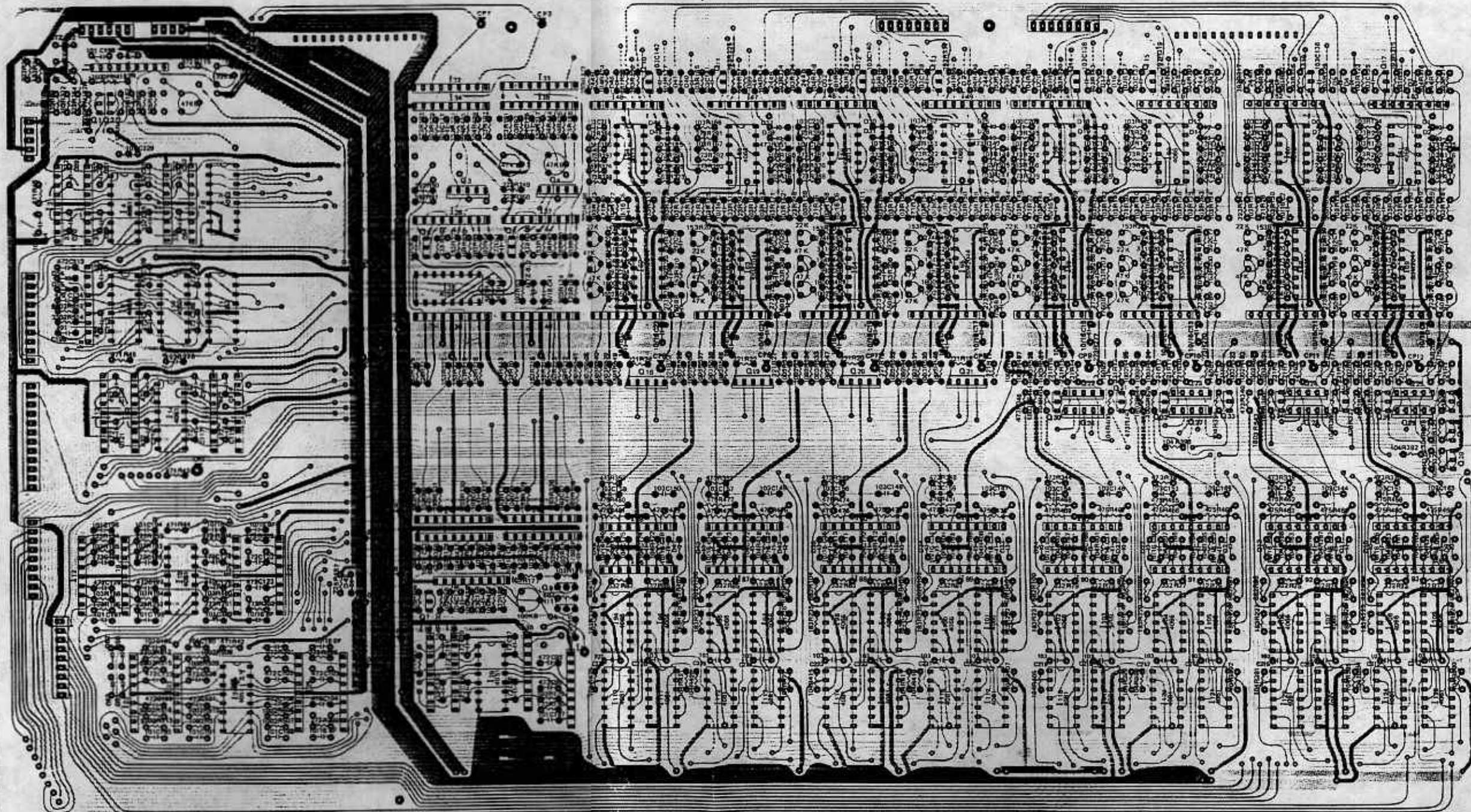

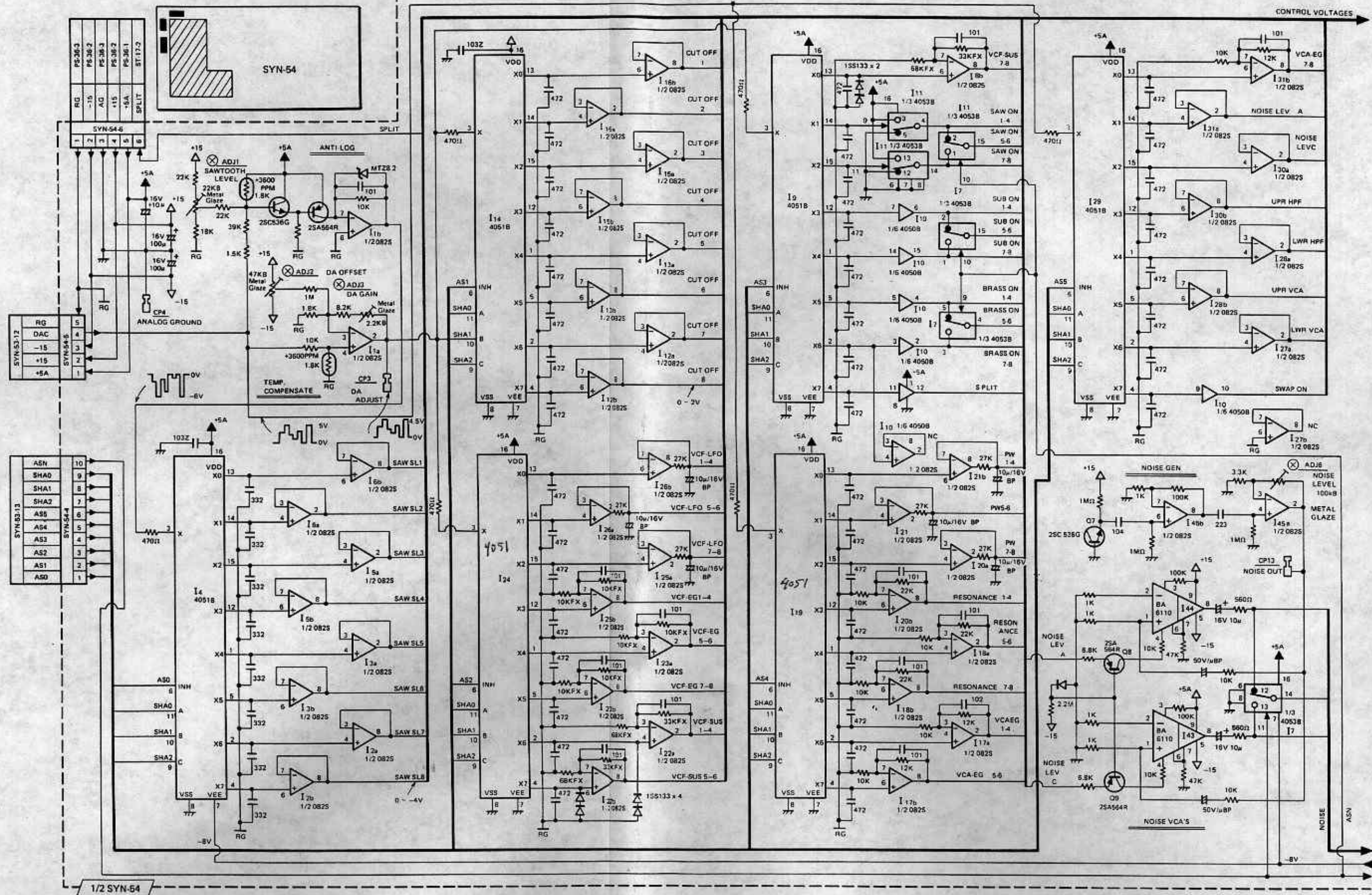

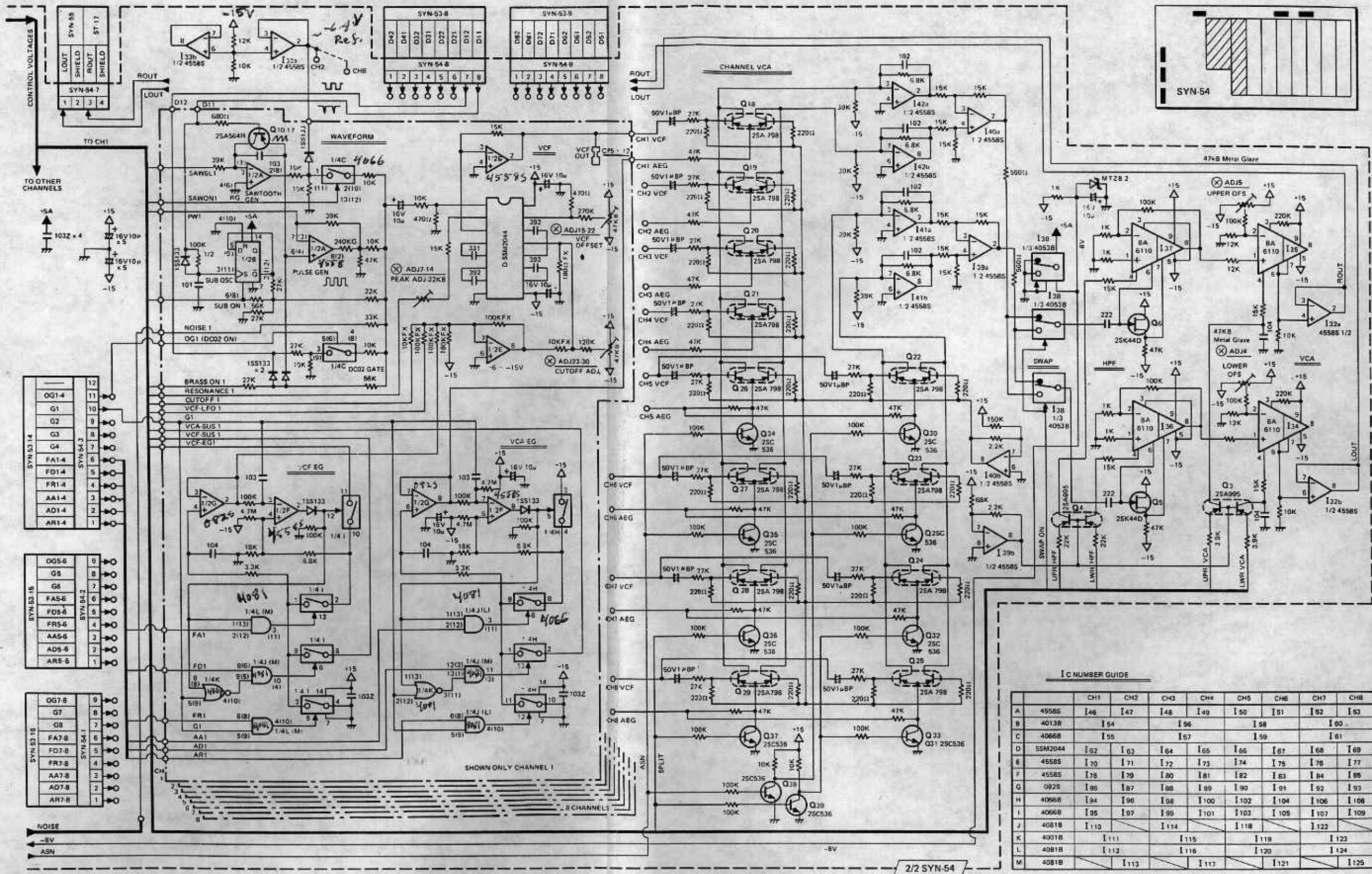

I.C. NUMBER GUIDE

	CH1	CH2	CH3	CH4	CH5	CH6	CH7	CH8
A	45585	I46	I47	I48	I49	I50	I51	I53
B	4013B	I54		I56		I58		I60
C	4066B	I55		I57		I59		I61
D	55M2044	I62	I63	I64	I65	I66	I67	I69
E	45585	I70	I71	I72	I73	I74	I75	I77
F	45585	I78	I79	I80	I81	I82	I83	I85
G	0825	I86	I87	I88	I89	I90	I91	I93
H	4066B	I94	I96	I98	I100	I102	I104	I106
I	4066B	I95	I97	I99	I101	I103	I105	I108
J	4081B	I110		I114		I118		I122
K	4001B	I111		I115		I119		I123
L	4081B	I112		I116		I120		I124
M	4081B	I113		I117		I121		I125

SYN-53-1								
DG	AD0	AD1	AD2	AD3	AD4	AD5	AD6	
DG	AD7	DG	SYN-51-4					

SYN-53-5								
1NC1	1NC2	DG	A0	A1	A2	A3	LR3	
LR2	LR1	LR0	FENA	SYN-51-3				

JA-07-1		
+50	DG	MC

SYN-51-1								
DG	B0	B1	B2	B3	B4	B5	B6	
DG	B7	SYN-53-2						

SYN-51-5							
DC0	DC1	DC2	DC3	DC4	DC5	DC6	DC7

SYN-51-6					
AC1	AC2	AC3	AC4	AC5	AC6

SYN-51-7				
AL0	AL3	AL4	AL5	

SYN-51-8								
AS0	AS3	AS4	AS5	DL0	DL1	DL2	DL3	
DL4	DL5	DL6	DL7	SYN-52-2				

SYN-51-9							
B0	B1	B2	B3	B4	B5	B6	B7

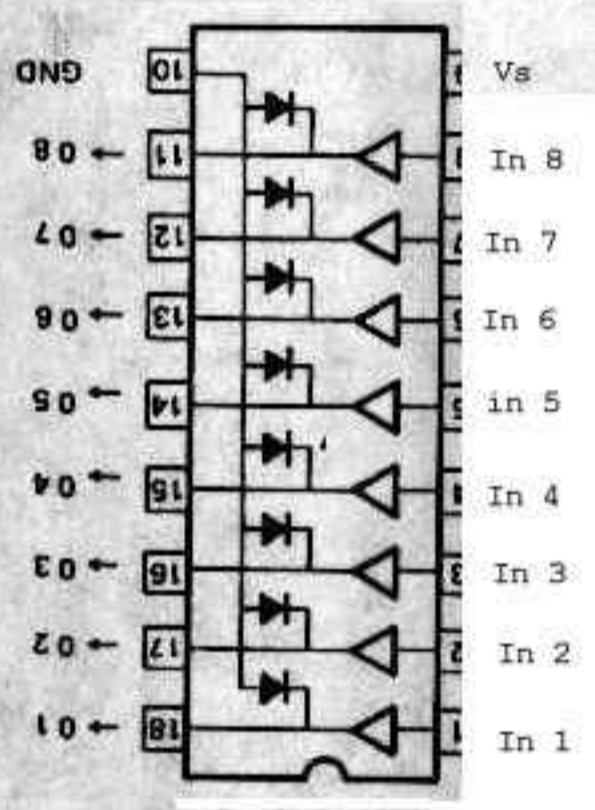
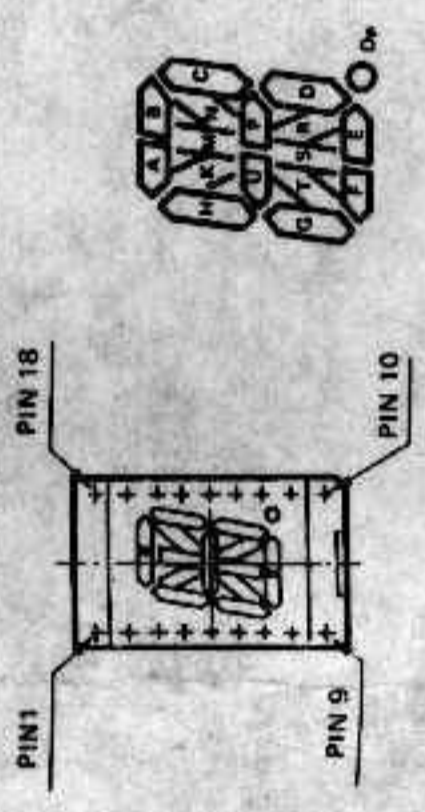
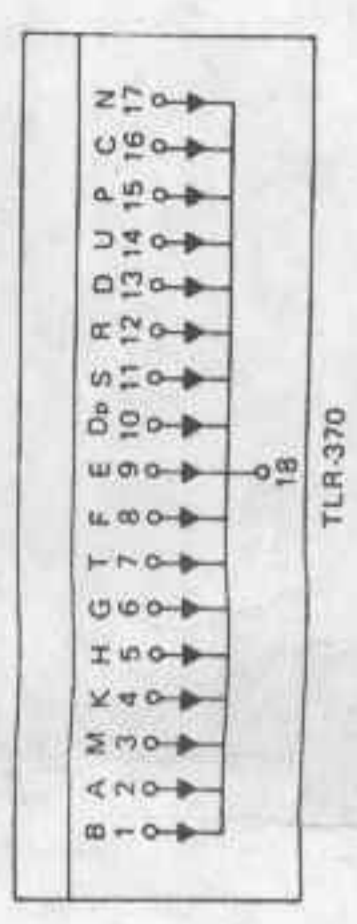
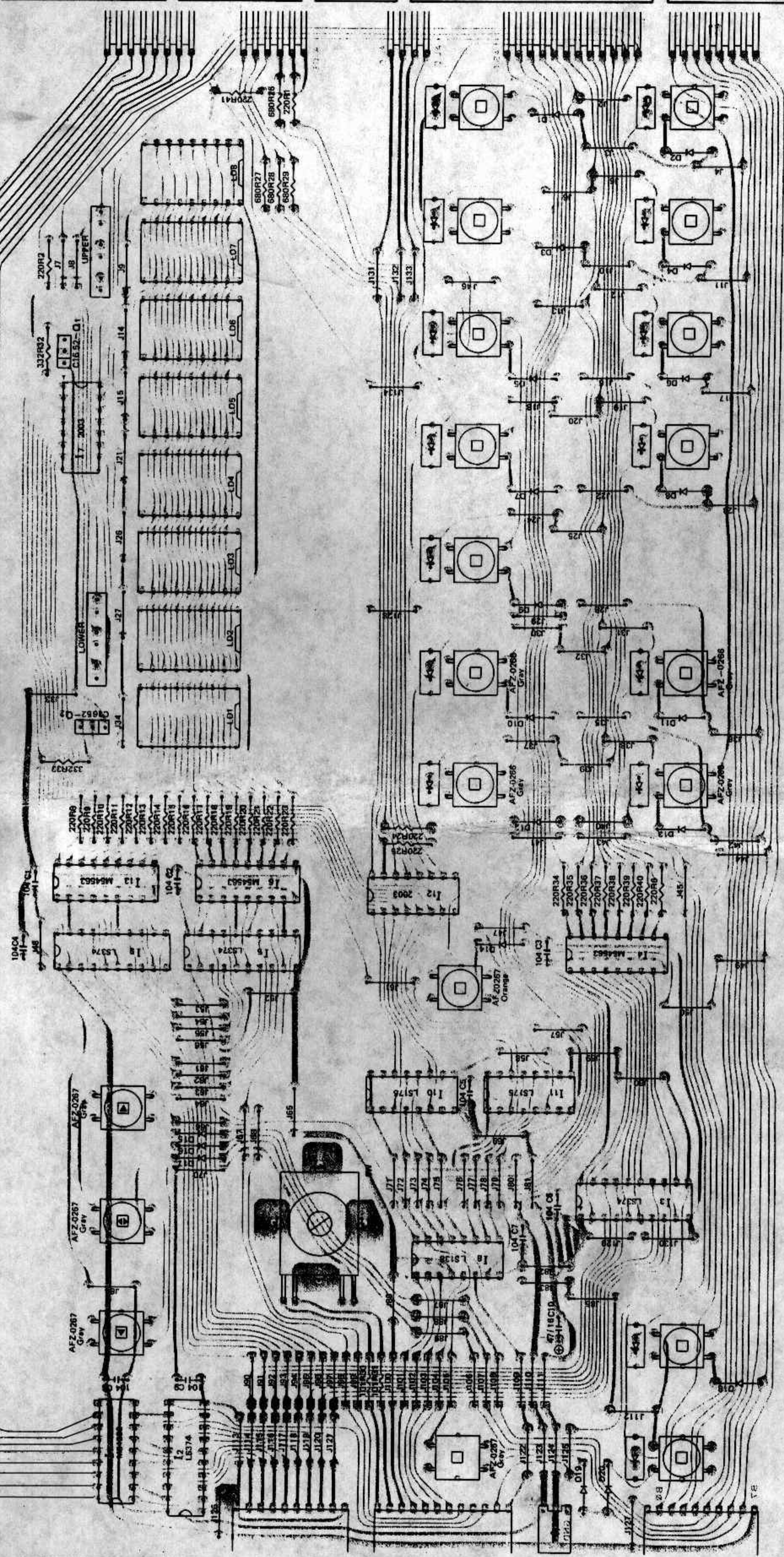

8-UNIT 500mA SOURCE TYPE DARLINGTON TRANSISTOR ARRAY
M54563P

B A M K H G T F E D S R D U P C N

SYN-51-9							
SYN-52-1							
B0	B1	B2	B3	B4	B5	B6	B7

SYN-51-8						
SYN-52-2						
AS0	AS3	AS4	AS5	AS6	AS7	AS8
DL0	DL1	DL2	DL3	DL4	DL5	DL6
DL7						

SYN-51-7				
SYN-52-3				
AL0	AL3	AL4	AL5	

SYN-51-6					
SYN-52-4					
AC1	AC2	AC3	AC4	AC5	AC6

SYN-51-5						
SYN-52-5						
DC0	DC1	DC2	DC3	DC4	DC5	DC6
DC7						

SYN-52 Terminals Information

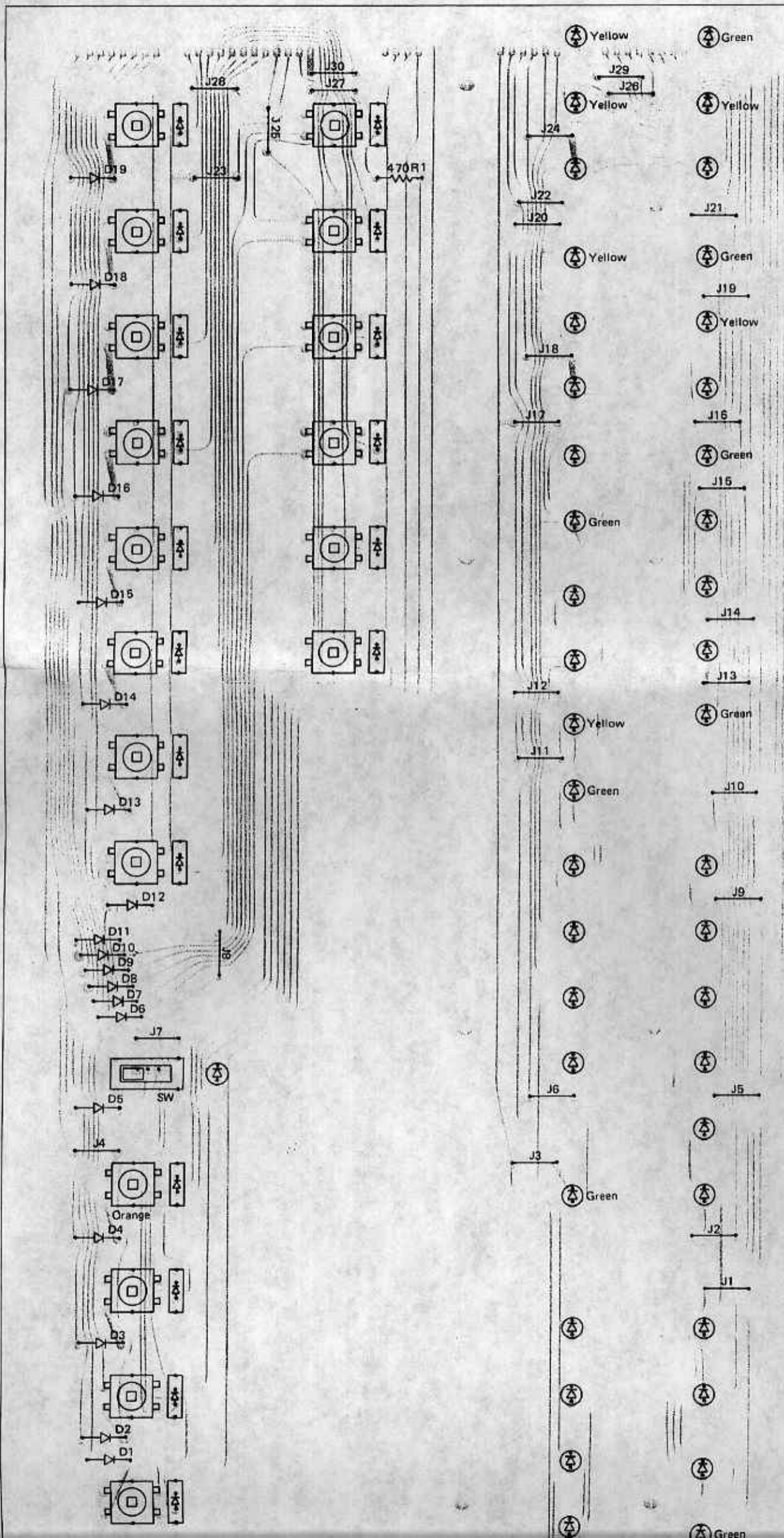

ST-17 TERMINALS INFORMATION

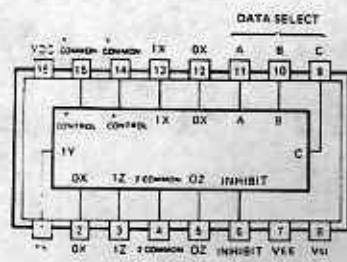
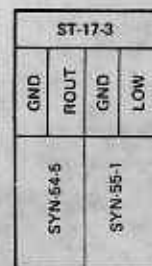
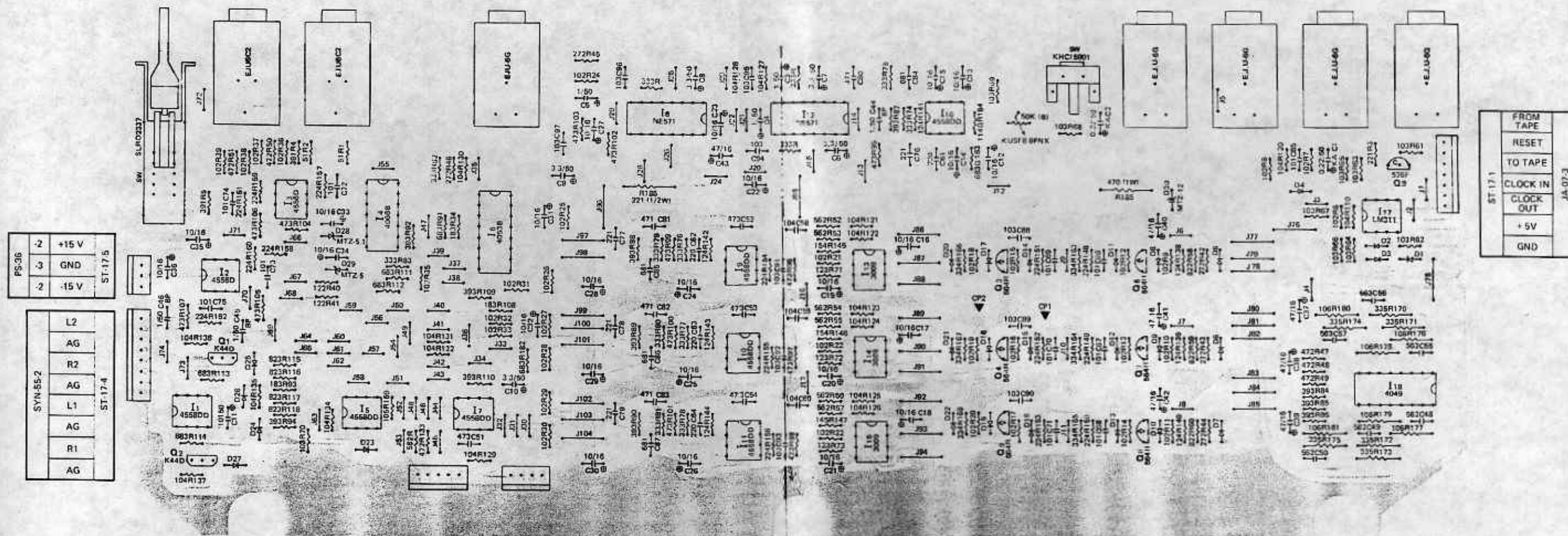

4053B
TRIPLE 2-CHANNEL MULTIPLEXER/DEMULPLEXER

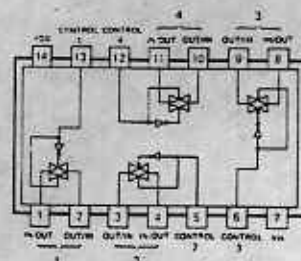

4066B QUAD BILATERAL SWITCH

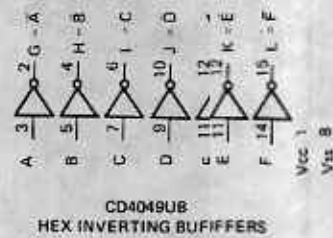

CD4049UB
HEX INVERTING BUFFERS

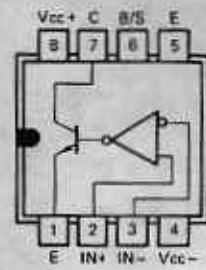

TL311
JFET-INPUT DIFFERENTIAL COMPARATOR WITH STROBE

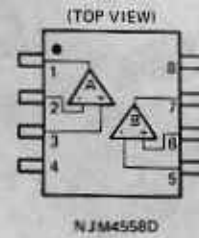

(TOP VIEW)
NJM4558D

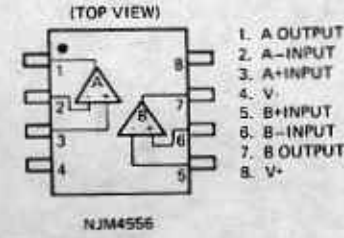

(TOP VIEW)
NJM4556

■JA-07·SYN-55 TERMINALS INFORMATION & CIRCUIT DIAGRAM

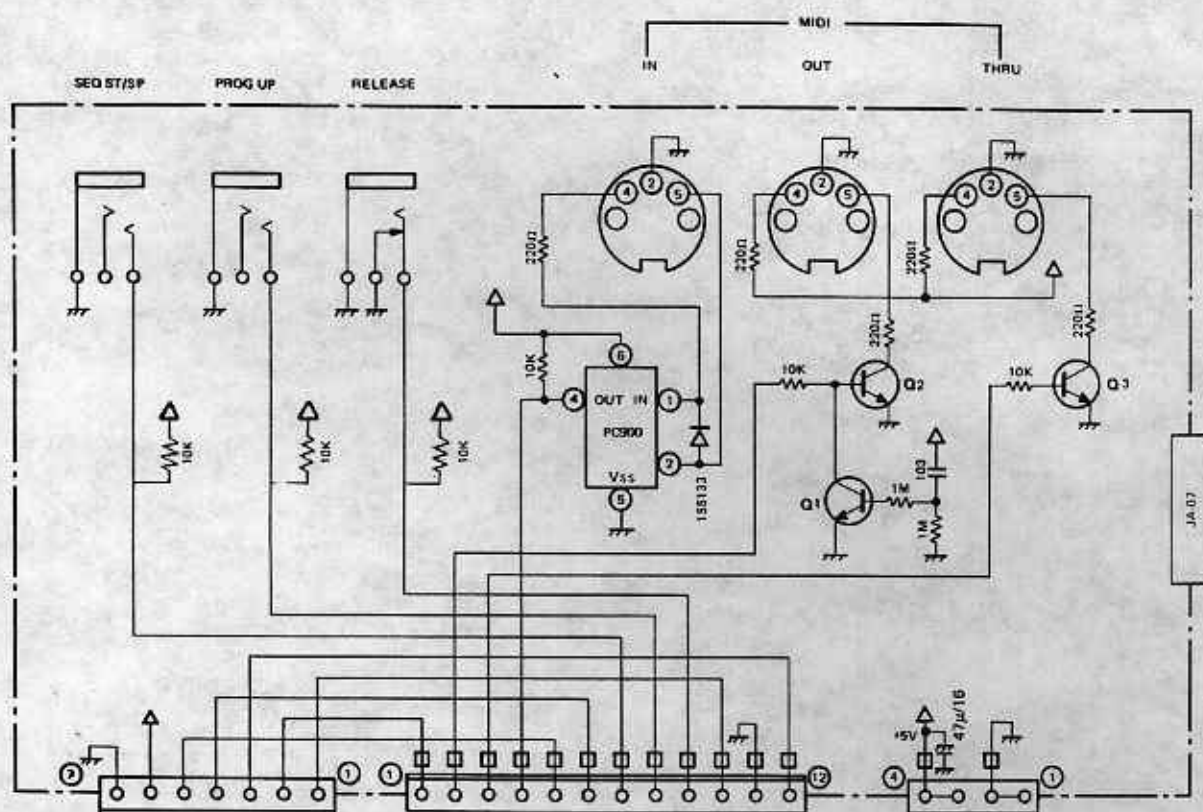

Q1 - 1-250536
 T - PC300
 □ - FERRITE

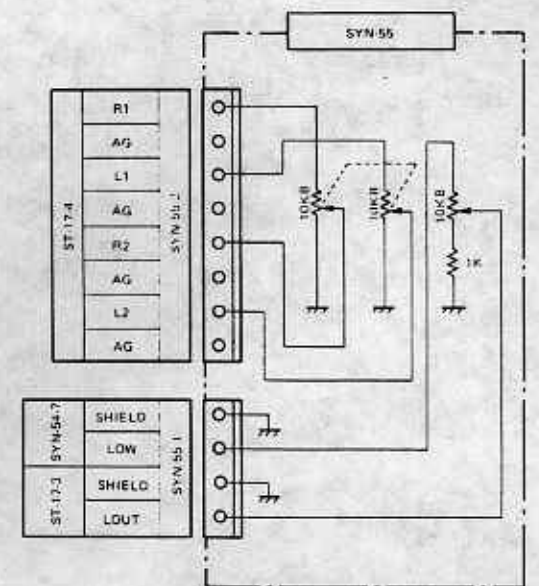

JA-07-3							
GND	+5	CLOCK OUT	CLOCK IN	TO TAPE	RESET	FROM TAPE	
ST-17-1							

JA-07-2											
RESET	MIDI OUT	MIDI	MIDI IN	CLOCK OUT	CLOCK IN	SEQ	PROG	DAMP	FROM TAPE	DG	TO TAPE
SYN-53-6											

JA-07-1	
+5D	GND
PS-36	

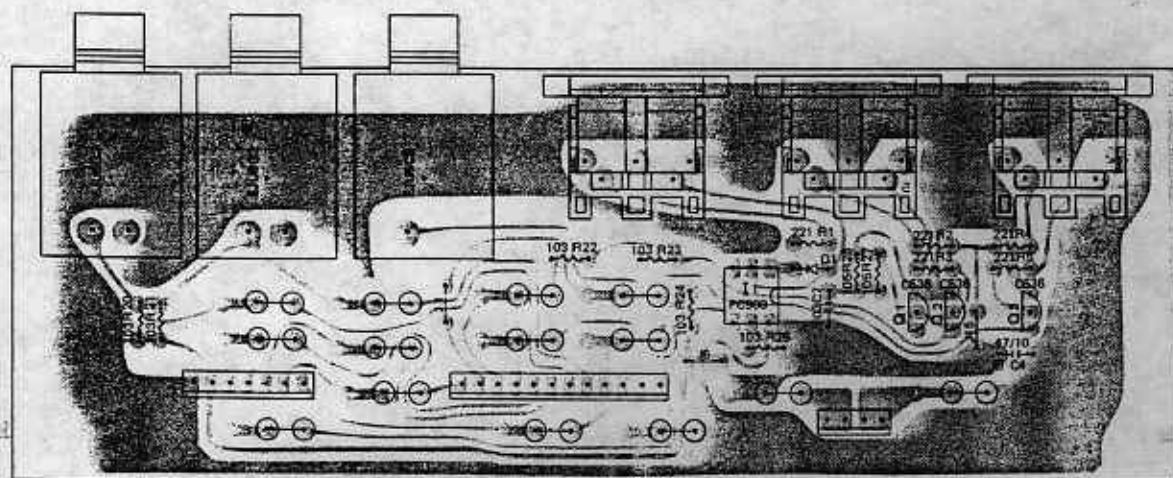

JA-07-3							
GND	+5V	CLOCK OUT	CLOCK IN	TO TAPE	RESET	FROM TAPE	
ST-17-1							

JA-07-2											
RESET	MIDI OUT	MIDI THR	MIDI IN	CLOCK OUT	CLOCK IN	SEQ	PROG	DAMP	FROM TAPE	DG	TO TAPE
SYN-53-6											

JA-07-1	
+5D	GND
PS-36	

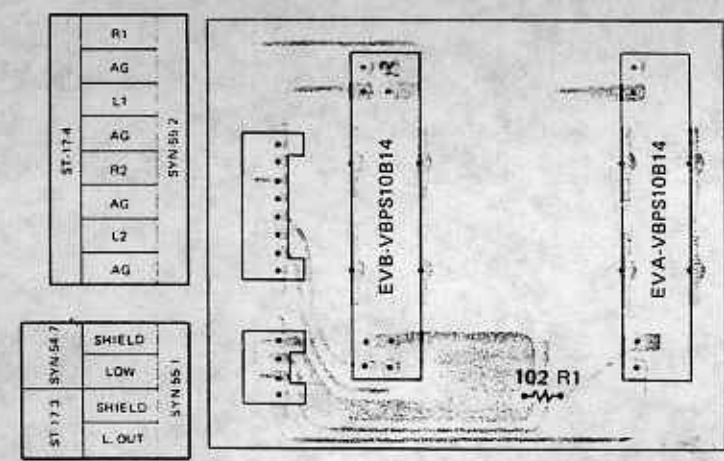

SYN-53 MASTER PROCESSOR AND SURROUNDING CIRCUITS

- * Reads in the key data from the keyboard and assigns the key to a tone generator channel.
- * Reads in the settings of the panel switches and performs the corresponding processing.
- * Gives signals to the panel indicators.
- * Monitors the INCREMENT operation and changes the parameters.
- * Sends and receives information associated with the external interface terminals such as MIDI-IN, PEDAL SWITCH, CLOCK IN/OUT, and TAPE.
- * Stores and reads tone and sequencer data to and from the DATA RAM.
- * Sends control instructions to the slave processor along the signal wire "COM" leading from pin #11. of the master CPU.

SYN-53 SLAVE PROCESSOR AND SURROUNDING CIRCUITS

- * Controls the tone generators and follows instructions from the master processor.
- * Sends data to the 10-bit DAC and generates the time-shared analog voltage.
- * Sends control signals to the "SAMPLE AND HOLD" circuits in SYN-54 and acts in response to the time-sharing output from the 10-bit DAC to generate the control voltages for the tone generator circuits.
- * Controls the DCO 1 and DCO 2 RATE GENERATORS and determines the DCO intervals. The output of a 12 MHz crystal oscillator is divided by three and then used to generate the pitch levels.
- * Controls the VCF- and VCA-EG RATE GENERATORS and determines the ATTACK TIME, DECAY TIME, and RELEASE TIME.
- * Sends the KEYING GATE signals to the "VCF-EG" and the "VCA-EG" circuits on SYN-54.
- * Controls the tone generator using the input voltage from the BENDER circuit.
- * Outputs MIDI-OUT signals under the direction of the master processor using the input voltage from the BENDER.
- * Sounds the BUZZER in response to instructions from the master processor.

SYN-54 ANTI-LOG

- * ANTI-LOG is a circuit that inputs a voltage proportional to the distance from the end of the keyboard and generates a voltage proportional to the frequency, which is used to make a sawtooth wave.

SYN-54 TEMPERATURE COMPENSATION AMPLIFIER

- * Corrects the voltage from DAC to offset the effects of temperature. It is used to prevent changes in VCF characteristics due to temperature.

SYN-54 SAMPLE AND HOLD

- * Inputs the direct signals from the 10-bit DAC, the signals that have passed through the ANTI-LOG AMPLIFIER, and the signals that have passed through the TEMPERATURE COMPENSATION AMPLIFIER and converts them into time-shared analog voltage, which goes to the tone generator circuits.

SYN-54 SAWTOOTH GENERATOR

- * Integrates the control voltages from SAMPLE AND HOLD. Generates a sawtooth wave of fixed amplitude each time it is reset by a pulse from the SYN-53 DCO 1 RATE GENERATOR.

SYN-54 PULSE WAVE GENERATOR

- * Generates the pulse wave of the variable DUTY CYCLE by comparing the control voltage from SAMPLE AND HOLD with the output of the SAWTOOTH GENERATOR.

SYN-54 SUB OSCILLATOR

- * Divides the pulse from the SYN-53 DCO 1 RATE GENERATOR and generates a square wave in the half rate of the pulse. The control voltage from SAMPLE AND HOLD switches the output on and off.

SYN-54 BRASS GATE

- * Uses outputs of the SAWTOOTH GENERATOR and the SYN-53 DCO 2 RATE GENERATOR to produce non-integral overtones. The control voltage from SAMPLE AND HOLD switches the output on and off.

SYN-54 DCO 2 GATE

*Use control signals from the SYN-53 OUTPUT PORT to switch on and off the square wave that is output from the SYN-53 DCO 2 RATE GENERATOR.

SYN-54 VCF

*Adds the outputs from the above SAWTOOTH GENERATOR, PULSE WAVE GENERATOR, SUB OSCILLATOR, BRASS GATE, and DCO 2 GATE, and the NOISE output. Acts as a LOW PASS FILTER.

*Takes the VCF CUTOFF voltage from SAMPLE AND HOLD, the VCF-LFO modulation voltage and sums them with the envelope waveform from VCF-EG to determine the CUTOFF FREQUENCY.

*The voltage that is output from SAMPLE AND HOLD determines the RESONANCE.

SYN-54 VCA

*Generates the envelopes corresponding to the pressing and releasing of the keys and uses these envelopes to shape the output.

*Channels 1 to 4 are connected to one VCA each while channel 5 to 8 are connected to two each. There are thus two summing outputs available—one for all eight channels and another for channels 5 to 8. This does not mean, however, that the outputs from this second set of channels go to two amplifiers; at any given time, each channel is connected to only one VCA. The pairing between these four channels and the amplifiers is determined by the SPLIT parameter (described below).

*When the SPLIT function is not activated, the output from each of these channels goes to the upper of the two amplifiers shown on the block diagram.

*The keyboard assignment "SPLIT ASSIGN 4-4" uses the same amplifiers for CHANNELS 1 to 4, but the lower ones for CHANNELS 5 to 8, yielding separate outputs.

*The keyboard assignment "SPLIT ASSIGN 6-2" uses the upper amplifiers for CHANNELS 1 to 6 and the lower ones for CHANNELS 7 to 8. The two keyboard assignments "SPLIT ASSIGN 6-2" and "SPLIT ASSIGN 2-6" are equivalent in terms of their effects on the VCA circuit. Similarly, "SPLIT ASSIGN 4-4" and "DUAL" produce the same effects on the tone generator circuits.

SYN-54 SWAP

*The keyboard assignment "SPLIT ASSIGN 2-6" assigns CHANNELS 1 to 6 to the UPPER output and Channels 7 and 8 to the LOWER. The SWAP circuit switches the two VCA outputs to yield the keyboard assignment "SPLIT ASSIGN 6-2".

The MASTER PROCESSOR assigns channels to individual keys on the keyboard. The SLAVE PROCESSOR performs the switching between the UPPER and LOWER tones.

The SWAP circuit uses the SAMPLE AND HOLD output to switch this function ON and OFF.

SYN-54 HPF

*Using the output of the SWAP circuit as input and the output of the SAMPLE AND HOLD circuit as control voltage; the HIGH PASS FILTER determines the CUTOFF frequency and changes the pass band. There are two such filters: one each for the UPPER and LOWER keyboards.

SYN-54 VCA

*Using the output of the HPF circuit as input and the output of the SAMPLE AND HOLD circuit as control voltage; the VCA controls the output volume. There are two amplifiers: one each for the UPPER and LOWER keyboards.

*The UPPER VCA output is input directly to the ST-17 board and that from the LOWER VCA is input to ST-17 via the "LOWER" volume control slider.

ST-17

*This board passes the audio signal that comes in from SYN-53 either directly to the GATE or through the ensemble modulation circuit when directed to do so by an "UPPER ENS-ON" or "LOWER ENS-ON" control signal. (TERMINAL ST-17-2 UE, LE)

*The GATE is provided to make sure that neither the shock noise generated when the power is switched on and off nor the volume fluctuations in volume when the tone is switched are passed on to later stages. The gate is controlled by the control signals from the internal time constant and the SYN-53 monostable multivibrator.

*The output of the GATE is transmitted, via the "VOLUME" control circuit, to the output stage amplifier where it is amplified for headphones.

*In the SPLIT-ON or DUAL-ON modes, the UPPER signal goes to the RIGHT channel, while the LOWER signal goes to the LEFT channel and they are output. When ensemble modulation is applied, the left and right signals have the same volume but are modulated with differing phases.

■SX-240 ADJUSTMENT

1. SYN-54 ADJ 2: D/A OFFSET

* Remove the offset voltage from the TEMPERATURE COMPENSATION AMPLIFIER.

* If this offset voltage is present, all VCF CUTOFF frequencies will uniformly undergo a large shift. Moreover, even when VCF-EG is set to zero, the envelope generator will still influence the VCF CUTOFF.

* Set the controls to SPLIT OFF and DUAL OFF and the UPPER/LOWER switch to UPPER. Set the "BASIC 240" parameters according to the list in Item 11.

* Connect SYN-54 CP4 (AG) to the oscilloscope ground and CP3 (D/A ADJ) to the oscilloscope probe. Adjust ADJ 2 until the lower limit of the waveform is less than ± 20 mV.

* SYN-54 ADJ 3 and SYN-54 ADJ 23 to ADJ 30 must now also be adjusted. (See later instructions)

2. SYN-54 ADJ 3: D/A GAIN

Adjust the gain of the TEMPERATURE COMPENSATION AMPLIFIER.

* If the gain setting is off, all the VCF CUTOFF frequency settings will be lost and, when the VCF-KCV parameter is in the range "70"-"75", the filters will not be able to track the keyboard. As a result, the tones will differ slightly between channels or the volume of the mellow sounds will change.

* Set the controls to SPLIT OFF and DUAL OFF and the UPPER/LOWER switch to UPPER. Set the "BASIC 240" parameters according to the list in Item 11.

* First, follow the SYN-54 ADJ 2 adjust procedure. Then, with the oscilloscope connection as they are, adjust ADJ 3 until the upper limit of the waveform is exactly 4.5 V.

* SYN-54 ADJ 23 to ADJ 30 must now also be adjusted. (See Item 5)

3. SYN-54 ADJ 7 to ADJ 14: RESONANCE

* Closely match the characteristics of each channel to the oscillator so that the VCF RESONANCE circuit is on the verge of self-resonance for "98" setting of the parameters.

* If the characteristics do not match, a large VCF-RESONANCE setting will yield tones that vary with the key that is pressed.

* Switch the POWER OFF and then ON again. Do not touch the keyboard. Switch SPLIT and DUAL to OFF.

* Set the "BASIC 240" parameters according to the list in Item 11.

* Set SAWTOOTH to OFF, VCF CUTOFF to "50," and VCF RESONANCE to "98."

* First, press key "C" located under the letter "O" printed on the panel. CHANNEL 1 (left edge) will be assigned to that note. Turn ADJ 7 counterclockwise until the oscillation starts. Turn it slowly clockwise until the oscillation stops. (By hearing or monitoring points CP-5 ~ 12)

* Release the "C" and press the "D" located immediately to the right. This note will be assigned CHANNEL 2. Adjust ADJ 8 following the same procedure as just used for ADJ 7.

* When the POWER is first applied, pressing different keys sequentially will assign the channels in order from CHANNEL 1. CHANNELS 1 to 8 can therefore be adjusted in order by going through the sequence of keys C-D-E-F-G-A-B-C starting with the key C.

4. SYN-54 ADJ 15 to ADJ 22: VCF OFFSET

* Adjust so that the VCF output waveform is centered at zero volts.

* If this output is offset, there will be distortion and clicking noise.

* Switch SPLIT and DUAL to OFF, UPPER/LOWER to UPPER.

* Set the "BASIC 240" parameters according to the list in Item 11.

* Set SAWTOOTH to OFF, VCF CUTOFF to "50," and VCF RESONANCE to "98."

* Connect SYN-54 CP4 (AG) to the oscilloscope ground and CP5 (VCF #1) to the probe. Adjust ADJ 15 until the trace reads zero volts. If a sine wave appears, first adjust SYN-54 ADJ 7 to ADJ 14.

* Repeat this procedure for CHANNELS 2 to 8. The measurement points for each channel are CP6 to CP12, and the adjustment controls are ADJ 16 to ADJ 22.

5. SYN-54 ADJ 23 to ADJ 30: VCF CUTOFF

* Correctly match the CUTOFF frequencies for each CHANNEL.

* If these frequencies differ, the TONE COLOR will differ between keys.

* Switch the POWER OFF and then ON again. Do not touch the keyboard. Switch SPLIT and DUAL to OFF.

* Set the "BASIC 240" parameters according to the list in Item 11.

* Set the VCF CUTOFF to "50" and press the second A# from the right end of the keyboard.

* Set the VCF RESONANCE to "98" and turn ADJ23 so that maximum voice is obtained. (You can also check the signal by using CP5) Now the CUTOFF frequency of channel 1 is correctly matched. Store this tone in one of the TONE MEMORIES.

* Switch the POWER OFF and then ON again. Do not touch the keyboard.

* Recall the previous tone. Set SAWTOOTH to OFF and VCF RESONANCE to "99."

* Press the "C" located under the letter "O" printed on the panel. The CHANNEL 1 VCF oscillation sound that was correctly adjusted previously should be audible.

* With the "C" still pressed, press the "D" to its right. Turn ADJ 24 (VCF #2) until the two sounds are at the same frequency. Release the "D" when finished.

* Similarly, with the "C" still pressed, press the "E" and adjust ADJ 25 (VCF #3). Repeat this procedure in the order of D-E-F-G-A-B-C to adjust the VCF CUTOFF frequencies for CHANNELS 2 to 8.

6. SYN-54 ADJ 1: SAWTOOTH LEVEL

- * Adjust the amplitude of the sawtooth wave.
- * If this amplitude is off, the tone will change or, even worse, the PULSE WAVE will no longer trigger a sound.
- * Switch SPLIT and DUAL to OFF, and UPPER/LOWER to UPPER.
- * Set the "BASIC 240" parameters according to the list in Item 11.
- * Set SAWTOOTH to OFF, PULSE to PW, and KYBD ASSIGN to MONO.
- * Connect SYN-54 CP4 (AG) to the oscilloscope ground and CP5 to the probe.
- * Press and release the "G" at the center of the keyboard.
- * Turn ADJ 1 until the waveform is a square wave with a 50% DUTY CYCLE.

7. SYN-54 ADJ 5: UPPER VCA OFFSET (CP2) ADJ 4: LOWER VCA OFFSET (CP1)

- * Remove the UPPER and LOWER VCA OFFSET voltages.
- * If these settings are off, modulated output will leak, and there will be clicking noise when the SPLIT and DUAL switches are operated.
- * Switch SPLIT to ON.
- * Set both UPPER and LOWER keyboards to the "BASIC 240" parameters listed in Item 11.
- * Set the UPPER VCA LFO to "99." Without touching the keyboard, adjust ADJ 5 until the LFO-modulated output is no longer audible.
- * Set the LOWER VCA LFO to "99." Without pressing the keyboard, adjust ADJ 4 so that the audible LFO modulation sound disappears.

8. SYN-54 ADJ 6: NOISE LEVEL

- * Adjust the NOISE LEVEL.
- * If the level is off, the NOISE portion will be either too loud or too soft.
- * Connect SYN-54 CP4 (AG) to the VTVM ground and CP13 (NOISE) to the probe. Turn ADJ 6 until the meter reads -10 dBm. The same measurement on an oscilloscope, should yield a reading of 1.5 Vp-p.
- * Note: The circuit is not built to withstand levels higher than the above.

9. SYN-53 ADJ 1: BENDER Adjustment

- * Adjust the voltage with the BENDER at the center position.

* If this voltage is off, the BENDER modulation will be uneven between right and left.

* Connect SYN-54 CP4 (AG) to the digital voltmeter ground and SYN-53 CP3 (BENDER) to the probe.

* Without touching the BENDER, turn SYN-53 ADJ 1 until the meter reads 2.50 V.



10. ST-17 ADJ 1: MODULATION DEPTH

- * Adjust the extent of the ensemble modulation.
- * If this setting is off, ensemble modulation will not yield the correct depth.
- * Connect ST-17 CP2 to the oscilloscope ground and CP1 to the probe.
- * Turn ST-17 ADJ 1 until the waveform covers 2.5 Vp-p on the DC range.
- * Note: The circuit is not built to withstand levels higher than the above.

11. "BASIC 240" PARAMETERS LIST

The following is a list of the parameter settings to be used as a standard tone for adjustment purposes.

- Key Label on PANEL
- IDENTIFIER Indication

CHORD	MEMORY	CHORD-OF
KYBD	ASSIGN	POLY -8
PORTA	SPEED	0. PORTA
DCO1		SAW  -ON
		PULS - OFF
	PW/PWM	0. PW-PWM
	SUB OSC	S-OSC-OF
DCO2	COARSE	0. COARS
	FINE	0. FINE
NOISE	LEVEL	0. NOISE
BRASS		BRASS-OF
VCF	CUTOFF	99. CUTOFF
	RESO	0. RESONA
	EG	0. VCF-EG
	KCV	0. F-KCV
	LFO	0. F-LFO
	BENDER	0. F-BEND
VCA	LFO	0. A-LFO
	EG	30. VCA-EG
HPF		0. HPF
ENSEM		ENSEM-OF
SPLIT	ASSIGN	SPLIT 2-6
SEQ	BEAT	4 BEAT
	TEMPO	50. TEMPO
TONE G.	RANGE	8 FEET
	LFO	0. O-LFO
	AUTO BEND	0. AUTOBND
	BENDER	0. O-BEND
	DCO2ON/OFF	DCO-2 OF
LFO	SPEED	99. LFOSPD
	DELAY	0. DELAY
	WAVEFORM	LFO-TRI
	REVERSE	REVSE-OF
VCF EG	ATTACK	0. F-ATAK
	DECAY	0. F-DCAY
	SUSTAIN	99. F-SUST
	RELEASE	0. F-RLS
LFO	TRIG	L-TRG-OF
VCA EG	ATTACK	0. A-ATAK
	DECAY	0. A-DCAY
	SUSTAIN	99. A-SUST
	RELEASE	0. A-RLS

12. RESET SWITCH

When the Reset Switch is pushed, then the contents of the tone memory change immediately to the condition of "Basic 240" and Sequenser's memory becomes to "Blank" condition.