

Preliminary operating
and service
information

DN728

Digital Delay Line



**Audio engineering
like no other
in the world**

CONTENTS

INTRODUCTION	4
INSTRUMENT FAMILIARISATION	5
USING THE DN728 DIGITAL DELAY LINE	7
Power on sequence	8
Viewing & changing the delay settings	8
Storing delay configurations	9
Recalling delay configurations	9
Changing operating level	10
Changing operating level	10
Creating a new delay line	11
Converting current delay modes	12
Relative modes	13
Protecting memories	14
Lock-out section	15
OPTIONS	17
AUDIO CONNECTIONS	18
INSTALLATION	19
SPECIFICATIONS	20
VOLTAGE SELECTION	21
WARRANTY	22
SERVICE REQUEST FORM	23
CIRCUIT DIAGRAMS	
Main PCB - microprocessor section	
Main PCB - analogue inputs	
Main PCB - D/A convertor	
Main PCB - analog outputs	
Main PCB - power supply	
Surface mount PCB - A/D convertor	
Surface mount PCB - parallel to serial convertor	
Surface mount PCB - audio timing	
Surface mount PCB - audio RAM address	
Meters and switch board	

Thank you for using this Klark-Teknik Product

To obtain maximum performance from this precision electronic product, please study these instructions carefully. Installation and operating the DN728 is not complicated, but the flexibility provided by its operating features merits familiarisation with its controls and connections. This unit has been prepared to comply with the power supply requirements, that exist in your location.

Precautions

Before connecting the unit to the mains power, ensure that the operating voltage is correct for your local supply.

Do not install this unit in a location subjected to excessive heat, dust or mechanical vibrations.

It is important that you observe the following instructions if another voltage setting is required.

Voltage Selection and Power Connection

Connection is made by means of an IEC standard power socket. The rear panel voltage label, indicates the voltage required for satisfactory operation of the unit.

Before connecting this unit to the mains supply, ensure the fuse fitted is the correct type and rating, as indicated on the rear panel, adjacent to the fuse holder.

To change the mains voltage please refer to "Voltage Change-Over" section on page 19.

* Mains voltage change should be carried out by a qualified service technician only.

Safety Warning

This unit is fitted with 3-pin power socket: For safety reasons the earth lead should not be disconnected. If you encounter a problem with earth-loops, remove the ground-lift link located inside the unit to isolate the signal earth from the chassis earth (see page 6)

To prevent shock or fire hazard, do not expose the unit to rain or moisture.

To avoid electrical shock do not remove covers. Refer servicing to qualified personnel only.

After you have unpacked the unit

Save all the packing materials - they will prove valuable should it become necessary to transport or ship this product.

Please inspect this unit carefully for any signs of damage incurred during transportation. It has undergone stringent quality control inspection and tests prior to packing and left the factory in perfect condition.

If, however, the unit shows any signs of damage, notify the transportation company without delay. Only you, the consignee, may institute a claim against the carrier for damage during transportation.

If necessary, contact your supplier or as a last resort, your Klark-Teknik importing agent*, who will fully co-operate under such circumstances.

* See enclosed world-wide importing agents list.

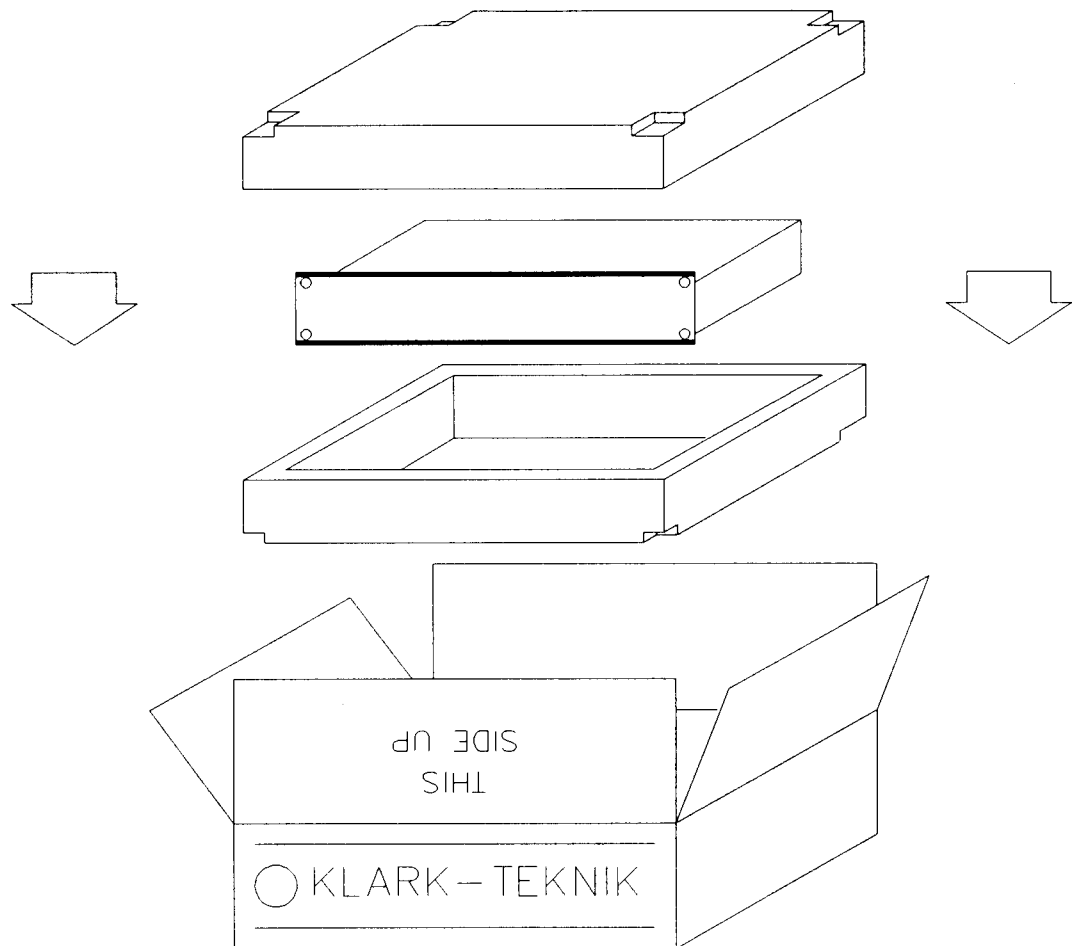

Introduction

The DN728 opens up a complete new world in digital delay lines, with two inputs, six outputs and a maximum delay of 1.3 Seconds (upgradable to 5.2 Seconds) virtually any required delay line configuration can be implemented. These configurations are easily set-up from the front panel controls and are automatically stored with delay settings in one of the 64 memories. Configurations can range from a three output stereo delay to a six output mono delay, including a dual delay where a variable amount of delay memory can be assigned to either channel and each output can be individually assigned to either channel.

Constructed in a one rack-space unit, the DN728 features state-of-the-art 64x-oversampling converters and linear-phase decimating filters. These give a full 18-bit resolution at an effective 200kHz sampling rate, ensuring flat frequency and phase response over a 20Hz-20kHz bandwidth and a typically 108dB dynamic range.

Delay resolution is 5 micro-Seconds allowing very accurate time alignment of drivers in multi-way loudspeaker systems. The delay settings can be displayed in units of time (micro-Seconds), distance (metres or feet) or video fields (PAL or NTSC). Delays can be set either as absolute or relative values, allowing quick and accurate alignment of delayed speaker stacks. When set in distance mode a temperature compensation facility is incorporated.

Each output has an independent digitally controlled output level, adjustable from -14dB to +4dB in 1dB steps, including mute. These are automatically stored with the delay settings in the user memories and can be recalled if required.

Various levels of control lock-out are provided, with the option of a user definable password for function access.

The DN728 also includes various retrofittable remote control interfaces including; Intelix Mind-Net, MIDI, RS422, GPI.

Reliability Control

Even with the advanced technology incorporated in this product, each instrument is given the full backing of Klark-Teknik's "reliability control" which proves each product against a specification consistent with the highest professional standards. Only top quality components are used and every unit is bench tested and aligned before a burn-in period and a final performance test is carried out after the burn-in period.

Instrument Familiarisation

Front panel functions

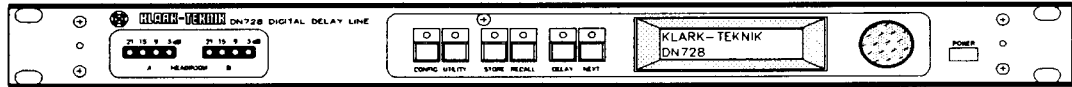

Headroom indicators

These are peak level indicators and are set up so that the red 3dB LED illuminates 3dB below the digital full scale (digital clipping).

CONFIG switch

This switch gains access to the configuration menu, which allows the construction of a new delay line, the control of the relevant remote interface if fitted and control of the security lock-out functions.

UTILITY switch

This switch gains access to the utility menu, which allows control of the individual output gains, conversion of the current operating delay to another mode (ie. milliSeconds to metres) and switching the relative mode on or off.

STORE switch

This switch is primarily used for storing the current delay to one of the 64 user memories, it has a secondary function in the menu modes for confirming a desired action.

RECALL switch

This switch is used for recalling one of the 64 user memories.

DELAY switch

The primary use for the delay switch is to select the display and control of the delay settings. Pressing the DELAY switch while in the delay mode will cause the toggling of the high and low speed settings.

NEXT switch

The primary use for this switch is in the delay mode to select the next output to be displayed and controlled. In the menu mode it is used for selecting the next option.

ROTARY controller

This is used for changing the displayed delay settings, menu options, memory numbers during store or recall modes etc. The parameter that is alterable by the rotary controller is always underlined in the display window.

Rear panel functions

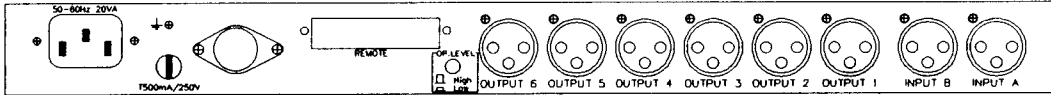

Mains Supplied via an IEC standard 3 pin connector. A compatible power cord is supplied with the unit.

Operating Voltage This is clearly marked on an adhesive label. See “Installation” for voltage change-over instructions.

Mains Fuse Located in a fuse holder fitted to the rear panel. Always replace with the correct type and rating of fuse, as indicated adjacent to the fuse holder.

Earth-lift link Located inside the unit. This disconnects the signal ground from the mains and chassis earth. This should be used if hum is attributable to earthloops and will generally solve the problem. It is also safe, unlike the practice of disconnecting the mains earth from the power cord.

Input and output connections Made via complementary XLR style connectors. For wiring details see “Audio Connections”.

Serial number Should be quoted in any correspondence concerning the unit.

OP. Level This switch sets the nominal operating level of the unit, with the switch out the ‘high’ operating level is selected. This allows a maximum signal level of +20dBu before signal clipping, in the ‘low’ position the maximum level is +10dBu.

Remote A cut out for the various retrofittable remote interfaces.

Using the DN728 Digital Delay Line

In understanding the DN728 it is probably best to consider the unit as a two input six output delay line, with a block of memory and each output having an independent level control. From this the control software is capable of allocating a percentage of the total memory to each input channel and assigning any output to either input channel. The software is also able to gang delay setting of outputs to allow for stereo outputs or even relative delay settings. In a stereo delay line for example, the total memory will be split 50% between each input. Outputs 1,2 and 3 will be assigned to input channel A and outputs 4,5 and 6 will be assigned to input channel B and outputs 1 and 4 will be ganged together as will outputs 2 & 5 and 3 & 6.

The configuration menu allows all these parameters to be set, allowing configurations such as a dual delay with one channel having a 100mS maximum delay with one output and the other channel 1.2 seconds of maximum delay and five outputs. With relative mode settings, one output for each channel is assigned as a base. When the delay setting for this output is changed all other outputs assigned to the same channel will automatically change by the same amount, if any other output apart from the base output is altered it will only effect that output, the display will always show its relative delay to the base output. The base channel is always the lowest numbered output assigned to the channel.

The DN728 is capable of setting an output delay in various forms - time, distance (metres,feet) and video fields. The time and video fields are directly converted into 5 micro-Second steps, the minimum resolution of the unit. The distance modes use the temperature parameter to convert the displayed distance to a time delay. This causes all the output delays to change when the temperature parameter is altered. The displayed delay setting in both time and distance mode is corrected for the inherent delay introduced by the sampling processes, hence the minimum delay settable in the time mode is 0.980 milliseconds.

Each output has a software adjustable gain control, which allows the output gain to be set from +4dB to -14dB in 1dB steps and the capability to mute the channel. Due to the fact the unit has a large dynamic range, the need for an input level control has virtually been avoided. But to allow for various operating levels a two position switch is provided on the rear panel, this allows for nominal operating levels of 0dB and +10dB each with 10dB's of headroom. In changing operating levels the set gain of each output is not affected, with the exception that due to output drive limitations a settable output gain above 0dB is not allowed in the high operating mode.

With the numerous delay configurations possible with the DN728 the sixty-four memories make it very easy to recall user defined delay line set-ups, each memory stores the complete configuration of the delay line, along with the settings of each output delay and output gains. When a memory is recalled the DN728 is reconfigured for the new delay, the output delay settings are updated and optionally the output gains are reset to the stored values. When storing a new or updated delay configuration the memory can be given a 10 character name, making the recall of specific memories fool-proof.

Using the security lock-out functions any number of the user memories can be protected from being accidentally modified. The lock-out functions also allow the unit to be made tamper-proof, at one level all settings can be locked and only memory recalls allowed, at the next level the memory recalls can also be made unavailable. As a final security measure access to the lock-out functions can be password protected, by a user defined 8 character code.

Power on sequence

During the power on sequence the unit performs a series of checks and displays certain messages. Any fatal errors found are shown by the switch LED's flashing and possibly an error message in the LCD display. If this happens the unit is unusable and should be switched off immediately. In a normal power on sequence the unit will display its software version number, the total amount of delay memory and what remote interface is connected if any. The unit will then configure itself to the delay mode it was in when it was last switched off and go into its 'idle mode' with the display showing the current configuration of the unit.

Viewing and changing the delay settings

Press the [DELAY] switch until its LED illuminates. The top line of the display will then show the current configuration and output. The bottom line will show the delay for that output.
e.g. 'Stereo Delay in milliseconds'

Stereo DELAY 1+4 40.80 <u>5</u> mSec

--{stereo pair outputs 1 and 4}

e.g. 'Dual Delay in metres'

Dual DELAY 1.A 38.45 <u>8</u> Metres

--{output 1 assign to input A}

By turning the rotary control the delay setting for that output can be altered. Note that the underline cursor in the display shows what the rotary control will change. Because the unit is capable of fine resolution and large range (one in a million) the cursor can be toggle across the decimal point by pressing the [DELAY] switch.

If the cursor does not appear then the setting control has been locked out (see Lock-out section).

Pressing the [NEXT] switch will cause the display to rotate through all the output settings.

If the unit has been set in distance mode (feet or metres) the unit will display the temperature that the unit is using to convert the distance to a delay time. Changing the temperature will cause all the outputs to change their delay times. If the delay values are headed by a + or - sign this signifies that the value is relative (see Relative section).

Storing delay configurations

Press the [STORE] switch until its LED illuminates.
The display will show:

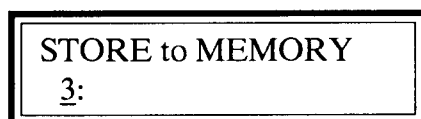

STORE to MEMORY
3:

This will be the next available empty memory. If required use the rotary control to select a different memory, memory numbers that appear to be missing will have been protected from being changed (see Protecting Memories section). Pressing the [NEXT] switch will cause the cursor to jump in the name area, use the rotary control and the [NEXT] switch to define a name (maximum of 12 characters). Finally to confirm the store press the [STORE] switch again, the display will confirm that the store has been completed.

Note: Pressing any other switch will abort the store sequence.

Recalling delay configurations

Press the [RECALL] switch until its LED illuminates.
The display will show:

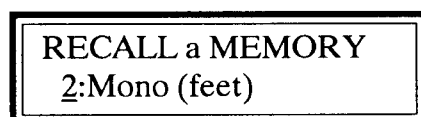

RECALL a MEMORY
2:Mono (feet)

This will be the last recalled memory. If required use the rotary control to select a different memory. Finally to confirm the recall press the [RECALL] switch again, the display will confirm that the recall has been completed. When the unit recalls a memory the outputs are automatically muted and the mutes are not released for a period of the maximum delay found for that memory.

Note: Pressing any other switch will abort the recall sequence.

Changing operating level

The unit is designed to work at two different operating levels, +10dBu and 0dBu. These are selected by a push button on the rear panel, when the switch is out the high level is selected. Both operating levels have 10dB's of headroom i.e. the high level has a maximum level of +20dBu, when the switch setting is changed the unit maintains an overall unity gain structure (assuming the output levels are at set 0dB).

Changing output level

Press the [UTILITY] switch until its LED illuminates.

The display will show:



UTILITY MENU:
OPT.1=LEVELS

If option 1 is not displayed adjust the rotary control.

Press the [NEXT] switch and the display will show:

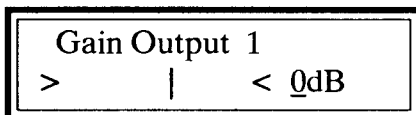

Gain Output 1
> | < 0dB

Use the rotary control to set the desired gain, the range is from -14dB to +4dB in the low level operating mode and -14dB to 0dB in the high level mode. The output can also be muted by going below -14dB, further pressing of the [NEXT] switch will cause the other five outputs to be displayed. After output 6 the display will show:



LEVELS RECALLED
FROM MEMORY= YES

This is a status flag which defines whether output levels are modified when a memory is recalled, the current output level is always saved when a delay configuration is stored to memory. Use the rotary control to set the required option.

Creating a new delay line

Press the [CONFIG.] switch until its LED illuminates.
The display will show:

```
CONFIG. MENU:  
OPT.1=NEW DELAY
```

If option 1 is not displayed adjust the rotary control.
Press the [NEXT] switch and the display will show:

```
NEW DELAY MENU  
Mode = STEREO
```

Use the rotary control to select the required mode STEREO, DUAL or MONO.
Press the [NEXT] switch when correct, the display will show:

```
NEW DELAY MENU  
Display= TIME
```

Use the rotary control to select the required display mode TIME, METRES, FEET, PAL video fields or NTSC video fields. Press the [NEXT] switch when correct, if the DUAL mode was previously selected the display will show:

```
NEW DELAY MENU  
Amax= 217Mt= 50%
```

This is the amount of the available memory assigned to the A channel, the display shows the maximum settable value in the current display mode and the percentage of memory. Use the rotary control to select the required amount of memory assigned to the A channel, the remainder is automatically assigned to the B channel. Press the [NEXT] switch when correct, in the STEREO mode this is automatically set to 50% and in the MONO to 100%.

The display will show:

```
NEW DELAY MENU  
Output 1 = A
```

This is the assignment channel for output 1, use the rotary control to select the required channel A or B. Press the [NEXT] switch when correct, and continue through all six outputs. IN the STEREO mode outputs 1, 2 and 3 are automatically assigned to the A channel and 4, 5 and 6 to the B channel, in the MONO mode all outputs are set to channel A.

When all six outputs have been assigned the display will show:

NEW DELAY MENU
Relative Md=OFF

This is a status flag to determine if the unit is in relative or absolute mode (see Relative section). Use the rotary control to select relative mode ON or OFF. If the unit is set to display video fields PAL or NTSC the relative mode is forced off. Press the [NEXT] switch when correct, the display will show:

NEW DELAY MENU
STORE KEY to USE

To set the unit to this new configuration press the [STORE] switch, press the [NEXT] switch to check or change the settings. Pressing any other switch will cause the new delay configuration to be abandoned.

Converting current delay modes

If the unit is running a delay line in display modes TIME, METRES or FEET it is possible to convert them into another mode. For example if the current delay was working in METRES and we wished to convert it into TIME:

Press the [UTILITY] switch until its LED illuminates.

The display will show:

UTILITY MENU:
OPT.1=LEVELS

Adjust the rotary control until the display shows:

UTILITY MENU:
OPT.2=CONVERSION

Press the [NEXT] switch and the display will show:

CONVERSION OPT.
Metre to Time

If the second line is incorrect adjust the rotary control. When correct press the [NEXT] switch, the display will show:

CONVERSION OPT.
at TEMP= +20'C

Adjust the rotary control to select the temperature at which to convert.
When converting between metres and feet there is no temperature setting.
When correct, press the [NEXT] switch, the display will show:

CONVERSION OPT.
STORE KEY to USE

To set the unit to this new display mode press the [STORE] switch, pressing any other switch will cause the conversion to be abandoned.

Relative modes

The DN728 is capable of displaying the output delay values in either absolute or relative modes. In the normal absolute mode, the displayed output value is the actual delay value, in the relative mode one output for each channel is a base value - this is displayed in absolute delay. All the other outputs assigned to that channel are displayed as relative to this base value, these displays are differentiated by having a + or - sign. This allows something like a delayed speaker tower to be time aligned, and by adjusting the base output the whole tower can be effectively moved without affecting the time alignment.

For example, if outputs 1, 2 and 3 are assigned to channel A and this was used for a delayed speaker tower where output 1 is used for the bass driver, output 2 for the mid range and output 3 for the horns. Outputs 2 and 3 the relative outputs could be time aligned to the bass driver, now by adjusting output 1 the delay for the whole tower could be adjusted without affecting the time alignment. In the relative mode the base delay is always the lowest numbered output assigned to the specific channel.

The relative mode can be defined when setting up a new delay line, it can also be switched on and off by the following method (there is no relative mode in the video fields display option).

Press the [UTILITY] switch until its LED illuminates.
The display will show:

UTILITY MENU:
OPT.1=LEVELS

Adjust the rotary control until the display shows:

UTILITY MENU:
OPT.3=RELATIVE

Press the [NEXT] switch and the display will show:

RELATIVE OPT.
Relative Md=OFF

Use the rotary control to select relative mode ON or OFF and press the [NEXT] switch to set.

Protecting memories

Memories with stored delay configurations, that should not be modified, can be protected. To protect a range of memories use the following method.

Press the [CONFIG.] switch until its LED illuminates.

The display will show:

CONFIG. MENU:
OPT.1=NEW DELAY

Adjust the rotary control until the display shows:

CONFIG. MENU:
OPT.3=LOCK-OUTS

Press the [NEXT] switch and the display will show:

LOCK-OUT MENU:
MEMORIES=NO

Adjust the rotary control until the display shows:

LOCK-OUT MENU:
MEMORIES=YES

Press the [NEXT] switch and the display will show:

MEMORY LOCK-OUT
OPT.1=LOCK MEM

Press the [NEXT] switch and the display will show:

LOCK MEMORIES
Range= 1 to 1

Use the rotary control and the [NEXT] switch to set a range of memories to be protected from being modified. Please note that unused memories in the range are not protected. When the range is correctly set press the [STORE] switch, the display will confirm the protection, pressing any other key will abort the operation.

To Unprotect a range of memories follow the same method, but use OPT2.
(see below)

MEMORY LOCK-OUT
OPT.1=LOCK MEM

Use the rotary control to select OPT.2=UNLOCK MEM before pressing the [NEXT] switch.

Lock-out section

The unit can easily be protected against unauthorised control, by setting two different lock-out functions, the first one 'SETTINGS' will stop any modification to the unit apart from allowing the recall of memories. This can also be defeated by setting the 'M.RECALL' lock-out, and the lock-out section itself can be protected by setting a user definable password. With all locks on and a password set the unit is completely protected from unauthorised tampering.

To set the various lock-out functions use the following method.

Press the [CONFIG.] switch until its LED illuminates.

The display will show:

CONFIG. MENU:
OPT.1=NEW DELAY

Adjust the rotary control until the display shows:

CONFIG. MENU:
OPT.3=LOCK-OUTS

Press the [NEXT] switch and the display will show:

LOCK-OUT MENU:
MEMORIES=NO

(Note: If the password has previously been set the unit will request the correct password first.)

Press the [NEXT] switch and the display will show:

LOCK-OUT MENU:
SETTINGS=LO LOCK

Use the rotary control to select SETTINGS=NO LOCK or LOCK and press the [NEXT] switch to set, the display will show:

LOCK-OUT MENU:
M.RECALL=NO LOCK

Use the rotary control to select M.RECALL=NO LOCK or LOCK and press the [NEXT] switch to set, the display will show:

LOCK-OUT MENU:
PASSWORD = OFF

Use the rotary control to select PASSWORD=OFF OR ON and press the [NEXT] switch to set. If password has been set OFF, the unit will return to its normal display otherwise it will show:

Enter Password..
===:xxxxxxx:===

'xxxxxxx' equals the current password, use the rotary control and the [NEXT] switch to define a password (maximum of 8 characters). Finally to confirm the password press the [STORE] switch, the display will confirm that the password has been set.

Options

5.2 Seconds of total memory

Relay fail-safe

Electronic output balancing

Transformer output balancing

Transformer input balancing*

Remote interfaces MIDI, Intelix-Mind Net, GPI

*Not retrofittable

Option Ordering information	Part number	Quantity
5.2 Seconds of total memory	MEM1M9	2 off
Relay fail-safe	RL728	6 off
Electronic output balancing	BE728	6 off
Transformer output balancing	BT728	6 off
Transformer input balancing*	BI728	

Memory upgrade procedure

- Remove both 256K * 9 SIMM modules from converter board.
- Insert two 1M * 9 SIMM modules.
- Remove 'MEM SIZE' link on main board (near remote connector).

Relay Fail Safe retrofit procedure

- Solder in six relays on main board at positions RLA-RLF.
- Remove solder bridging on reverse of main board under each relay (12 bridges to remove).
- Use links provided to select the by-pass channel for each output, the connection options are printed on the main board.

Balanced output retrofit procedure

- Remove resistors and links from positions LK3-LK14.
- Solder in six transformers or electronic balancing cards to positions TX3-TX8.
- Remove link LK2 located between input socket B and output socket 1.

Audio Connections

Input

The input circuitry is a transformerless, electronically balanced design which achieves a symmetry of better than -50dB from 20Hz to 10kHz.

If transformer balancing of the input is required, this must be specified at the time of order - it is not retrofittable.

Output

The standard output is unbalanced, but balancing transformers and electronic balancing are available and may be retrospectively fitted.

The output unbalanced output XLR connections are: Pin 1 circuit ground; Pin 3 circuit ground and Pin 2 signal.

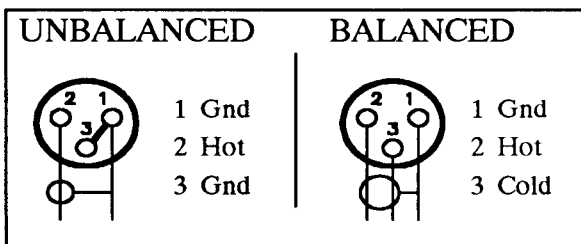

Balanced Circuits

Transformer or electronically balanced connections have the benefit of “common mode rejection” which eliminates externally induced interference such as mains hum etc. Balancing is especially useful when long cable runs are used between pieces of equipment.

Transformer balanced circuits have the added advantage of being, “full floating” with the ground (earth) or screen being totally isolated from the signal. In installations where a difference in earth potential is likely to occur this isolation prevents grounding problems which can, in some cases, damage the equipment.

If used unbalanced, either Pin 2 or Pin 3 can be used for signal providing the unused Pin is connected to Pin 1.

Installation

Mounting

The DN728 is designed for standard 19 inch rack mounting and is 44mm (1.75 inch) high and 300mm (11.75 inch) deep, excluding connectors. Observe the following when mounting:-

- 1) Use a well ventilated rack.
- 2) Do not mount on top of heat producing equipment.
- 3) Use fan assisted ventilation if rack exceeds 40°C

Specifications

Inputs

Type	Two via 3-pin XLR Electronically balanced
Impedance (ohm)	
Balanced	20k
Unbalanced	10k
Max Level	+20dBu

Outputs

Type	Six via 3-pin XLR unbalanced (pin 2 hot)
Min. Load Impedance	600 ohms
Source Impedance	<60 ohms
Max Level	+20dB

Performance

Frequency response	+/- 0.5dB (20Hz-20kHz)
Total harmonic distortion	<0.05% (20Hz-20kHz @ +8dBu)
Dynamic Range	Typically 108dB
Max Delay	1.3 seconds (optional 5.2 seconds)
Minimum increment	5 uS (2mm in distance mode)
Digital conversion	18 bit PCM
Effective sample rate	200kHz

Power Requirements

Voltage	110/120/220/240V @ 50/60Hz AC
Consumption	<20VA

Weight

Nett	2.5kg
Shipping	4.2kg

Dimensions

Width	482mm (19 inch)
Depth	300mm (11.75 inch)
Height	44mm (1.75 inch)

Terminations

Inputs	3 Pin XLR
Outputs	3 Pin XLR
Power	3 Pin CEE

IMPORTANT WARNING
THIS APPLIANCE MUST BE EARTHED

The wires in the supplied mains lead are coloured in accordance with the following code:

Green and Yellow	Earth
Blue	Neutral
Brown	Live

As the colours of the wires in the mains lead may not correspond with the coloured markings identifying the terminals in your plug, proceed as follows:

The wire which is coloured Green and Yellow must be connected to the terminal in the plug that is marked with the letter E or by the Earth symbol \perp or coloured Green or Green and Yellow.

The wire which is coloured Blue must be connected to the terminal that is marked with the letter N or coloured Black.

The wire which is coloured Brown must be connected to the terminal which is marked with the letter L or coloured Red.

Voltage Selection and Power Connection

Connection is made by means of an IEC standard power socket. The rear panel voltage label indicates the voltage required for satisfactory operation of the unit. Before connecting the unit to the mains power, ensure that the operating voltage is correct for your local supply. It is important that you observe the following instructions if another voltage setting is required. The unit may be set for 240v or 120v operation (50-60Hz) by means of the labelled internal slide switch. These ranges may be changed to 220v and 110v if preferred by means of the other, similar slide switch, according to the internal voltage selection label.

Note: All internal adjustments, including voltage changes, must be carried out only by qualified service personnel.

Before connecting this unit to the mains supply, ensure the fuse fitted is the correct type and rating is as indicated on the rear panel, adjacent to the fuse holder. Should the fuse need replacing, it should be replaced only with the same type and value of fuse.

Do not install this unit in a location subjected to excessive heat, dust or mechanical vibrations.

Warranty

This product is manufactured by Klark-Teknik and is warranted to be free from defects in components and factory workmanship under normal use and service for a period of one year from the date of purchase.

During the warranty period, Klark-Teknik will undertake to repair or at its option, replace this product at no charge to its owner when failing to perform as specified, provided the unit is returned shipping pre-paid, to the factory or authorised service facility.*

No other warranty is expressed or implied.

This warranty shall not be applicable and be void when this product is subjected to:

- a) Repair work or alteration be persons other than those authorised by Klark-Teknik in such a manner as to injure, in the sole judgement of Klark-Teknik, the performance, stability, reliability or safety of this product.
- b) Misuse, negligence, accident, act of God, war or civil insurrection.
- c) Connection, installation, adjustment or use otherwise than in accordance with the instructions provided by Klark-Teknik.

* See enclosed service request form.

Klark-Teknik reserves the right to alter specifications without notice. This warranty does not affect the statutory rights of the UK customer.

COPYMASTER DO NOT REMOVE

NOTE! This sheet is your Copymaster. Please duplicate on photocopier when needed.

Service Request Form

Please complete this form and send it to Klark-Teknik before returning the unit. Attach duplicate to the returned unit.

NAME.....TELEPHONE.....

ADDRESS.....

MODEL No.....SERIAL No.....

PURCHASED FROM.....DATE.....

Please tick appropriate box

REPLACEMENT PACKING REQUIRED YES NO

- 1) Describe symptoms of malfunction
- 2) Which channel(s) exhibit(s) the problem?
- 3) Under what conditions does the problem occur?
 - a) All the time
 - b) After a while
 - c) At high signal levels
 - d) At high temperature levels
 - e) Other (please explain)

Is the fault: permanent intermittent

- 4) What did you do to isolate the problem to this unit?
- 5) Further comments.

Important Note:

It is often useful to call your dealer or the factory explaining the nature of the problem with the unit. In many instances the problem can be solved without returning the unit to the factory. If the unit has to be returned to the factory, use the original packing only. If you do not have the original packing, we will provide a replacement.

Factory authorised service facilities are located throughout the world. Call your dealer or the factory for the location of the service facility nearest you.

Klark Teknik PLC
Klark Industrial Park
Walter Nash Road
Kidderminster
Worcestershire
DY11 7HJ
England

Tel: +44 (0)562 741515
Fax: +44 (0)562 745371
Telex: 339821 KLARTK G

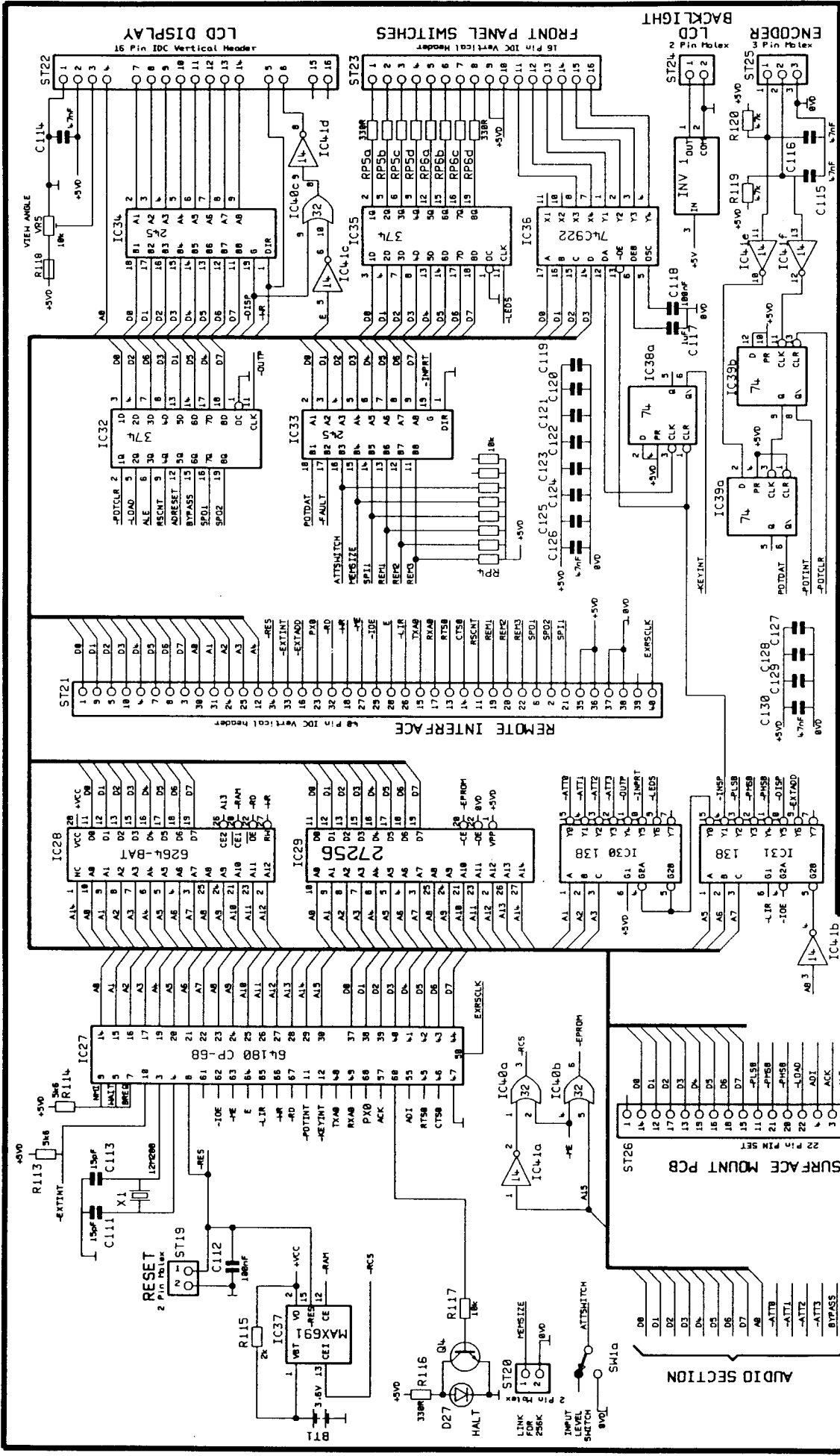

KLARK-TEKNIK RESEARCH

DN728 DELAY LINE MAIN PCB - MICROPROCESSOR SECTION

BOARD No. 2739-2 DWG No. 728_01.DGM 1 OF 5 09.APR.92

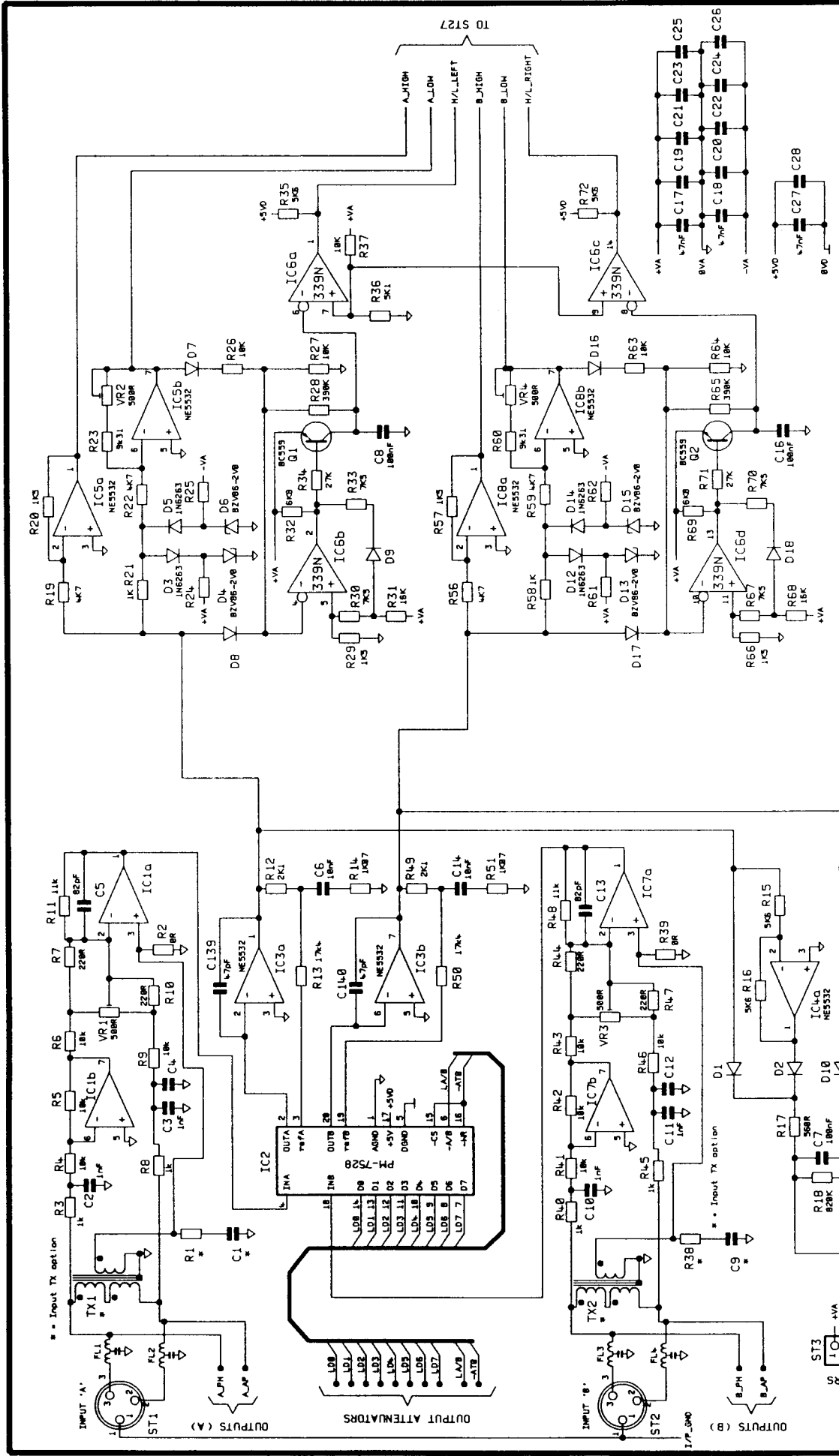

KLARK-TEKNIK RESEARCH

DN728 DELAY LINE MAIN PCB - ANALOG INPUTS

PCB 2739-2 DWG No. 728_02.DGM 2 OF 5 09.APR.92

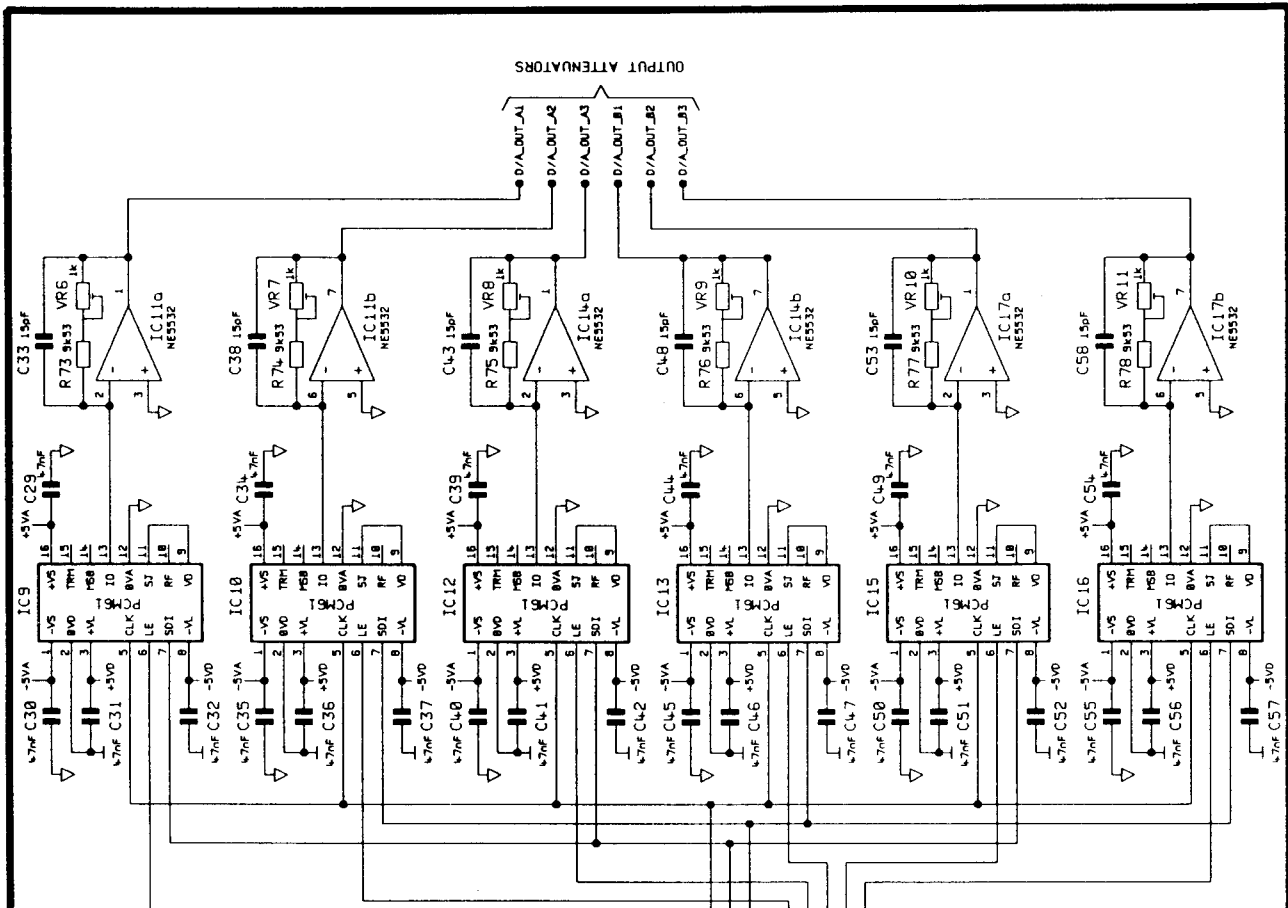

OUTPUT ATTENUATORS

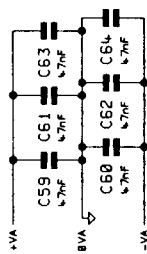

FROM POWER SUPPLY

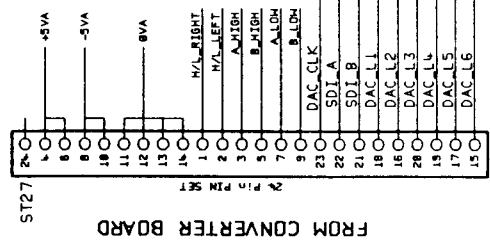
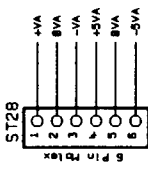

KLARK-TEKNIK RESEARCH
 DN728 DELAY LINE MAIN PCB - D/A CONVERTER
 PCB 2739-2 DWG No.728_03.DGM 3 OF 5 09.APR.92

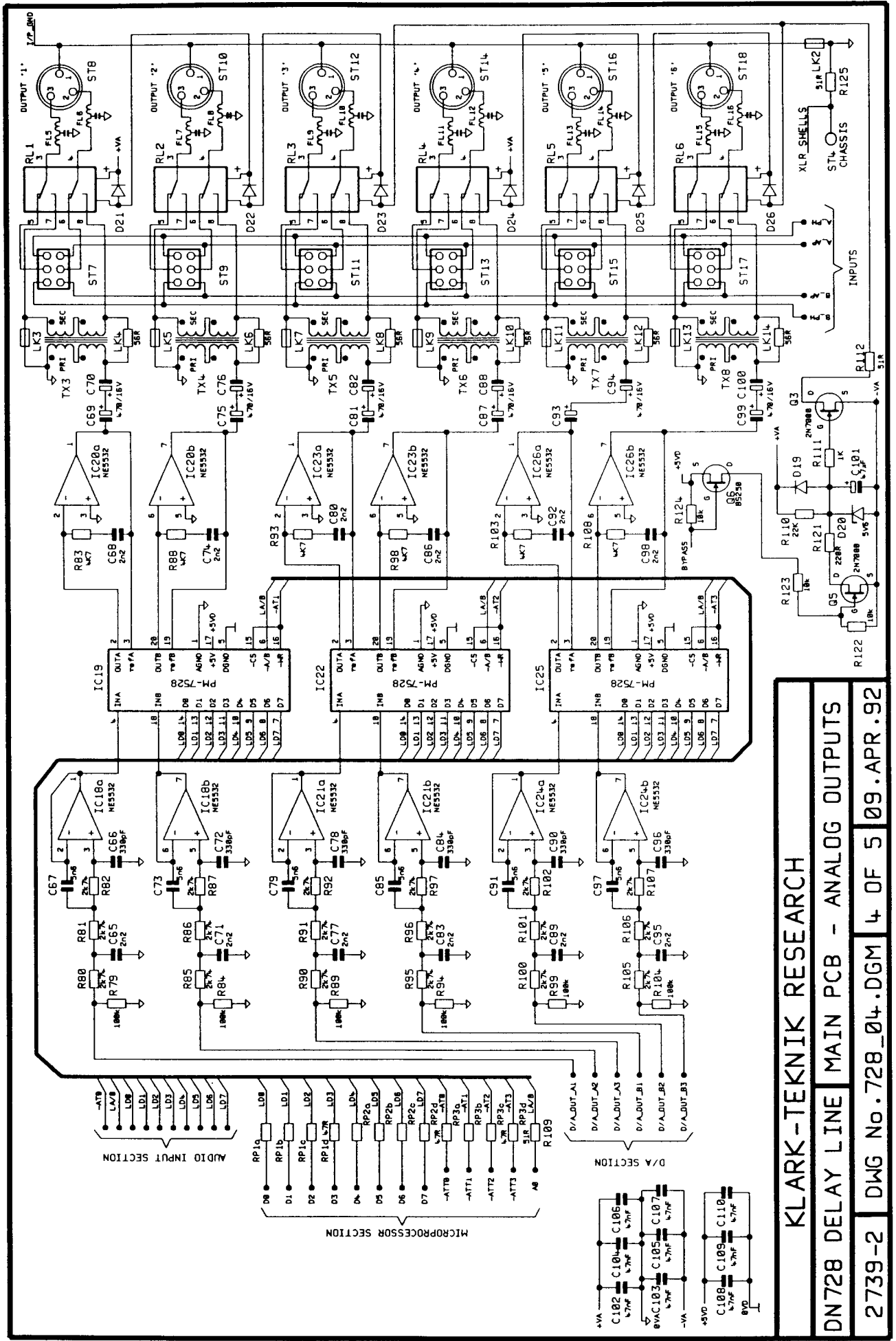

KLARK-TEKNIK RESEARCH

DN728 DELAY LINE MAIN PCB - ANALOG OUTPUTS

2739-2 DWG No. 728_04.DGM 4 OF 5 09.APR.92

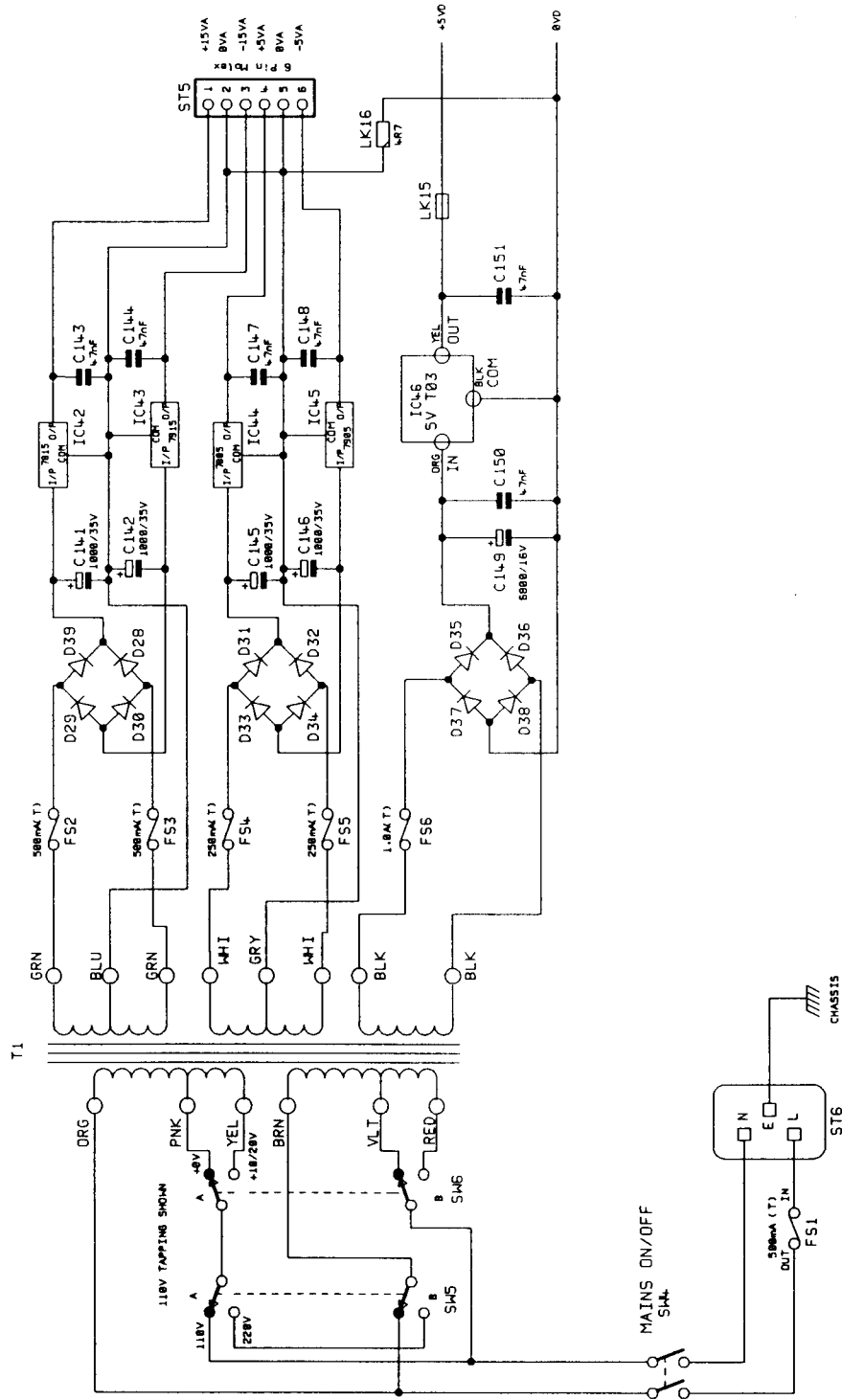

KLARK-TEKNIK RESEARCH

DN728 DELAY LINE

MAIN PCB - POWER SUPPLY

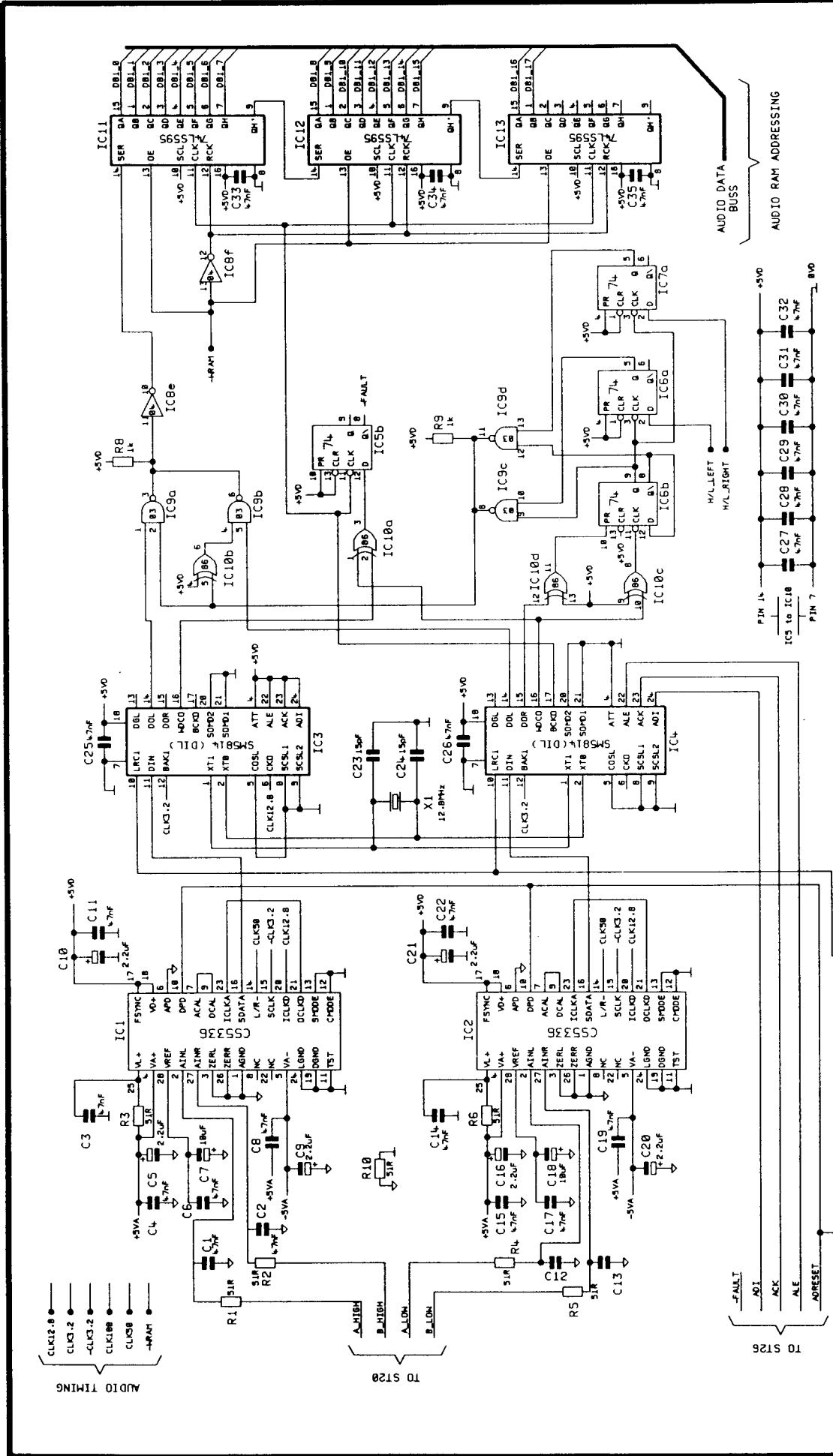

KLARK-TEKNIK RESEARCH

DN728 DELAY LINE SURFACE MOUNT PCB - A/D CONVERTOR

PCB 2738-2 DWG No. 728_11.DGM 1 OF 4 09.APR.92

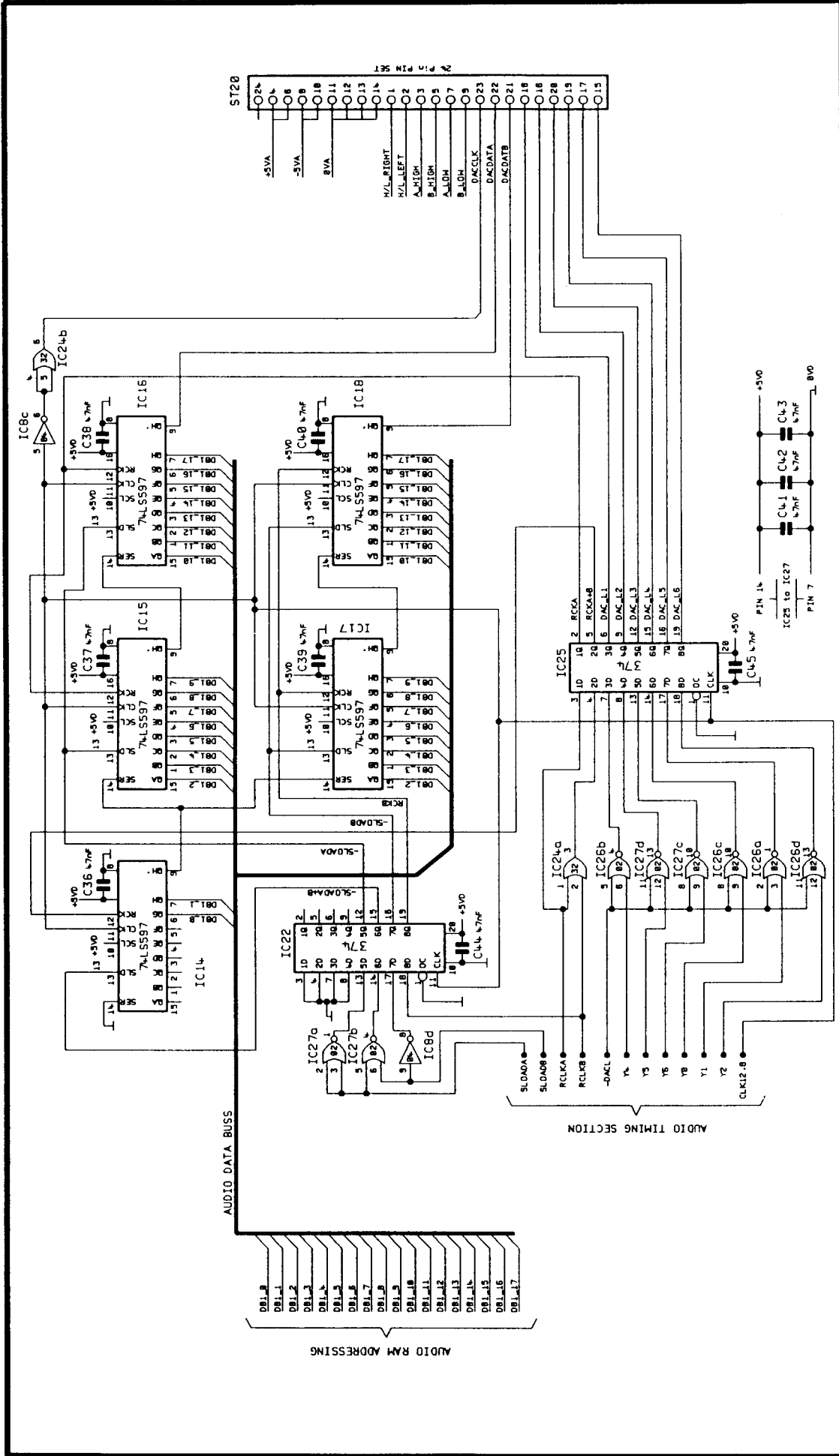

KLARK-TEKNIK RESEARCH

DN728 DELAY LINE SURFACE MOUNT PCB - PAR-SER CONVERTER

PCB 2738-2 DWG No. 728_12.DGM 2 OF 4 09.APR.92

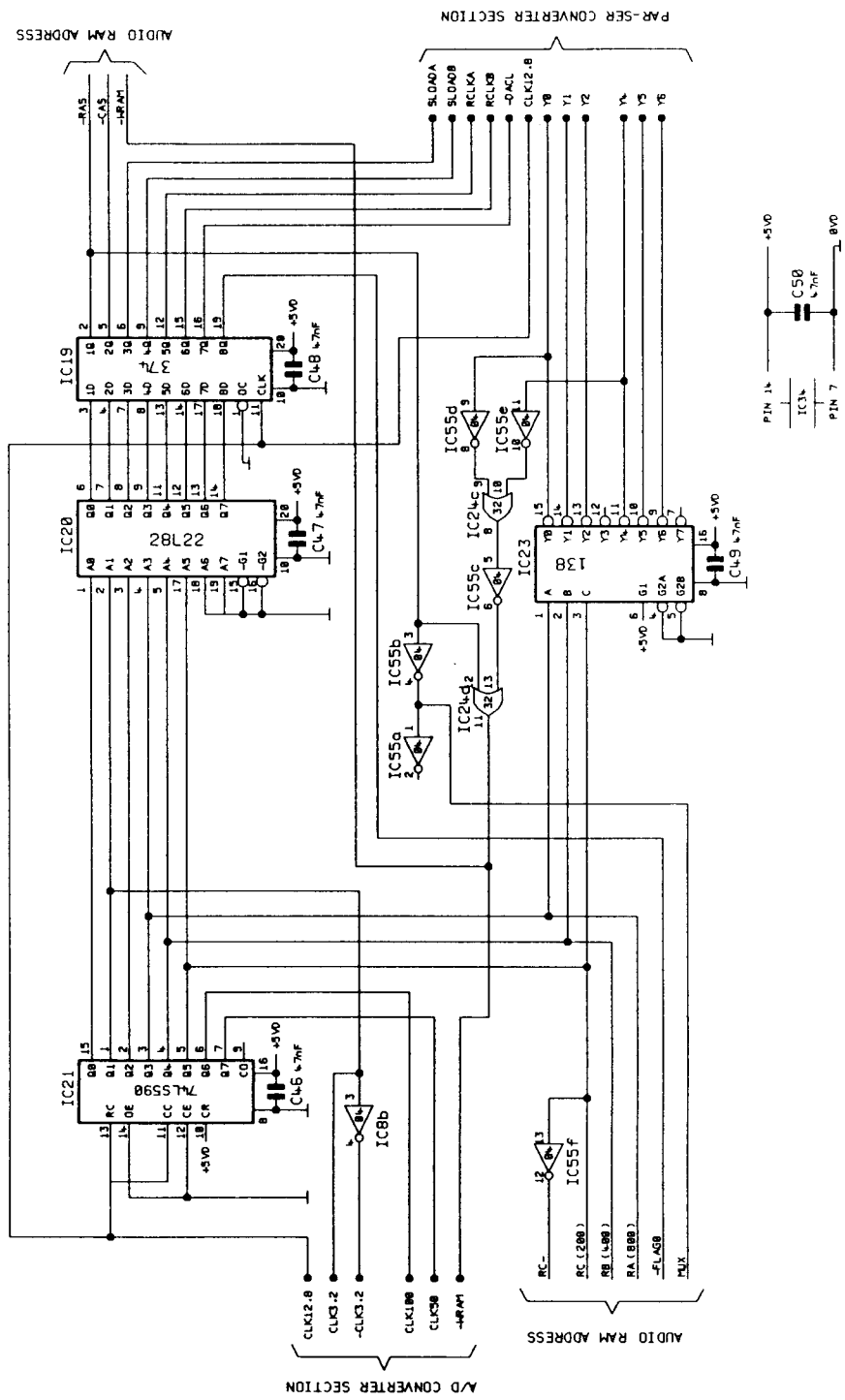

KLARK-TEKNIK RESEARCH

DN728 DELAY LINE SURFACE MOUNT PCB - AUDIO TIMING

PCB 2738-2

DWG No. 728_13.DGM

3 OF 4 15.June.92

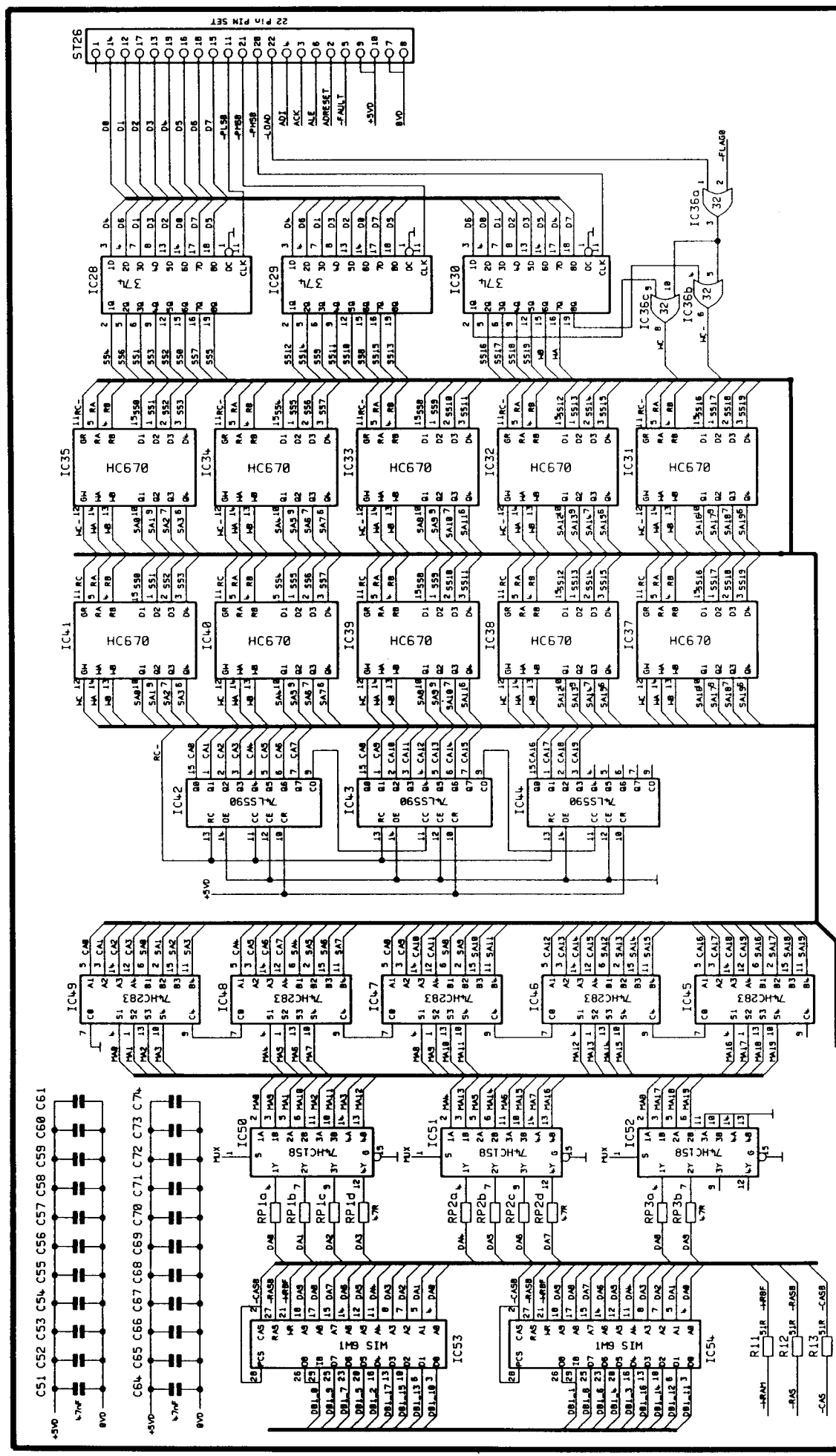

KLARK-TEKNIK RESEARCH

DN728 DELAY LINE SURFACE MOUNT PCB - AUDIO RAM ADDRESS

PCB 2738-2 DWG No.728_14.DGM 4 OF 4 09.APR.92

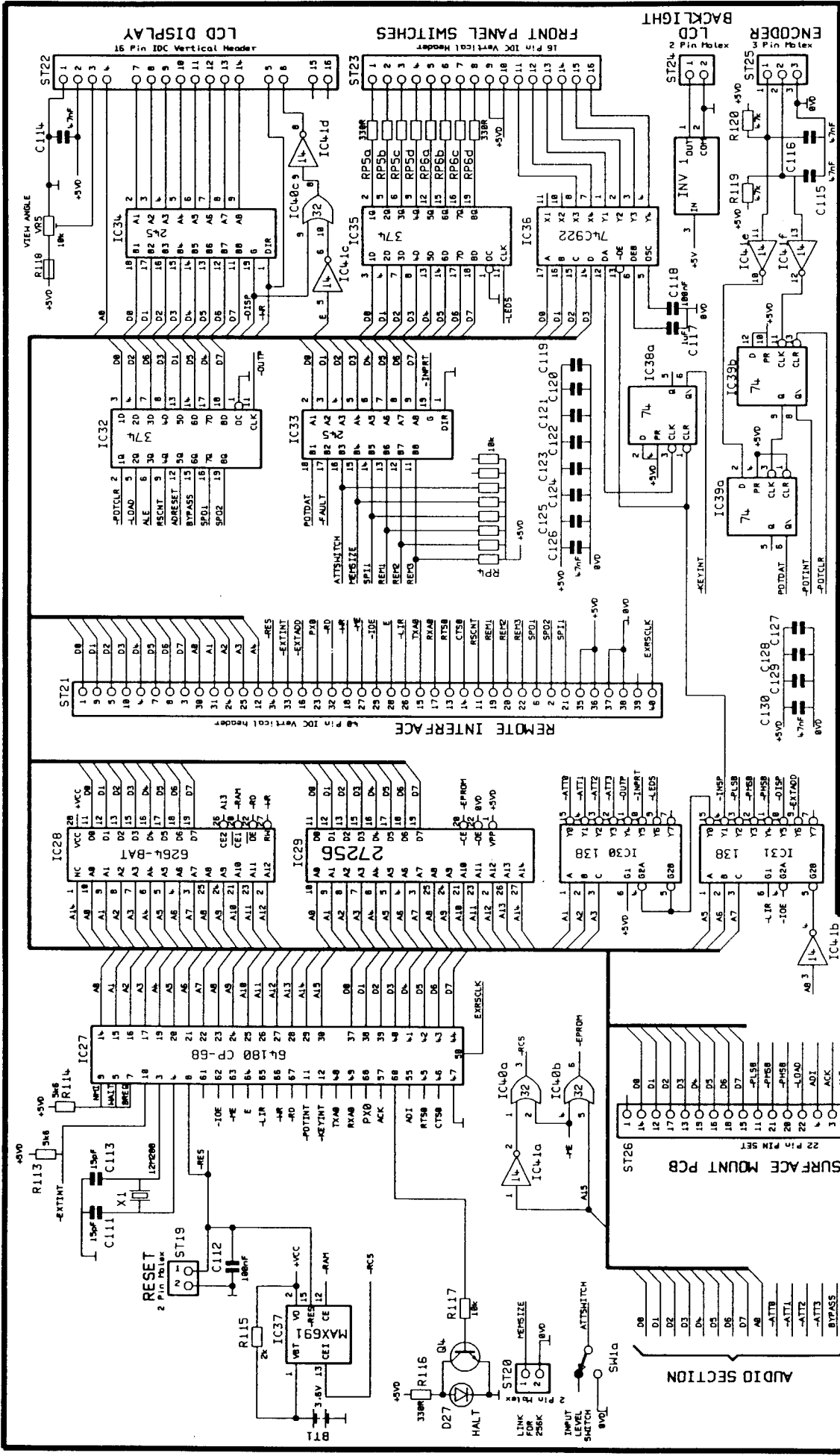

KLARK-TEKNIK RESEARCH

DN728 DELAY LINE MAIN PCB - MICROPROCESSOR SECTION

BOARD No. 2739-2 DWG No. 728_01.DGM 1 OF 5 09.APR.92