

Service Manual

PA50

CONTENTS

Page:

- 1. Technical Specification
- 2-24. Circuit & Block & Structural Diagram
- 25-78. QA Full inspection (Diagnostics and tests performed at factory)
- 79-83. Parts List

1st Edition

Issued date: April 13th 2004

Issued by: KORG INC.

Edited by: Korg USA

January 13, 2005

TECHNICAL SPECIFICATIONS

Model: KORG PA50	
Keyboard	61 keys, with velocity
Operating System	KORG OPOS(Objective Portable Operating System) . Multitasking . Load While-Play feature . SSD (Solid state disk)-resident . Upgradable from floppy disk .
Display	Backlight custom LCD
Data storage	8MB(>20MB equivalent) Internal Solid State disk(SSD), 1.44MB floppy Disk Driver(MS-DOS compatible)
Sound generation system	KORG Hi-Hyper Integrated.
Polyphony	62 voices . 62 oscillators . Filters with resonance.
Multitimbricity	40 tracks (2 x 16 Sequencer , 4 Realtime , 4 Pads)
Sound memory	32 Mbyte of PCM ROM , with Stereo Piano
Programs	>660(Single oscillator Double Oscillater),including Stereo Piano and GM level 2-compatible Programes 32Drum kits, 128 User programs 64 User drum kits easy and Full Program Editing.
Effects	4 stereo digital multi-effect systems (with 89 effect types each)
Performances	160 Realtime Performance Memories . Up to 304 Styles Performances with 4 Single Touch Setting each.
Styles	Up to 304 Styles ,Solid State Disk-resident , freely reconfigurable 8 Style tracks , 4 Single Touch Settings per-Style , 48 User Styles , programmable Style Performance and Single Touch Settings . Direct Disk reading features . Compatible with old i-Series Styles . Style Record with Edit Functions , Step Edit , Event Edit .
Single Touch Settings (STS)	4 x 304 (memorize Realtime tracks)
Style controls	4 Variations , 2 Fills , 2 Intros , 2 Endings , Counter In / Break , Synchro Start / Stop . Tap Tempo / Reset , Fade In / Out , Bass Inversion , Manual Bass , Tempo Lock , Memory , Accompaniment Volume , Accmpaniment Mute , Drum Mapping , Snare & Kick Designation , Single Touch .
General controls	Mater volume , Ensemble , Octave Transpose , Master Transpose , So it Point , Style Change . Tracks Volume . Quarter of Tone , Assignable Slider , Joystick , Dial .
Pads	4 Assignable Pads + Stop button.
Song play	XDS Crossfade Dual Sequencer player . 2 Sequencers with separate . Start / Stop , Pause, <<(Rewind) and >> (Fast Forward) controls . Balance control . Lyrics data are displayed on-screen . Jukebox function . SMF Direct player (formats 0 and 1)
Song / Backing Sequence	Easy Record function . Full featured sequencer . 16 tracks . SMF native format.
Pedals	Damper , Assignable (continuous .footswitch)
Realtime controllers	Joystick(pitch+modulation) , Assignable slider , Pads)
MIDI	IN , OUT , THRU . Individual track assignement . Auto-setup functions (MIDI Setup)
Audio Inputs	2 x In, line impedance
Audio Outputs	2 Main (Left/Mono , Right)
Main Amplifier	2 x 15 Watt Amplifier
Speakers	2 double-cone speakers (bass-reflex box) .
Power Consumption	26W
Dimensions	W:1054mm, D:393 mm, H : 150 mm (wihtout music stand).
Weight	11.25kg.
Accessories	User's Manual , Switch Adapter & AC Power cable , Music Stand .
Options	EXP-2 (Foot Controller), XVP-10 (Exp/Volume Pedal), PS-1 (Footswitch), DS-1H (Damper Pedal)

a	5SBXB030120B2B0	Screw 3 x12BB	16
Ref.	Code	Description	Q.ty

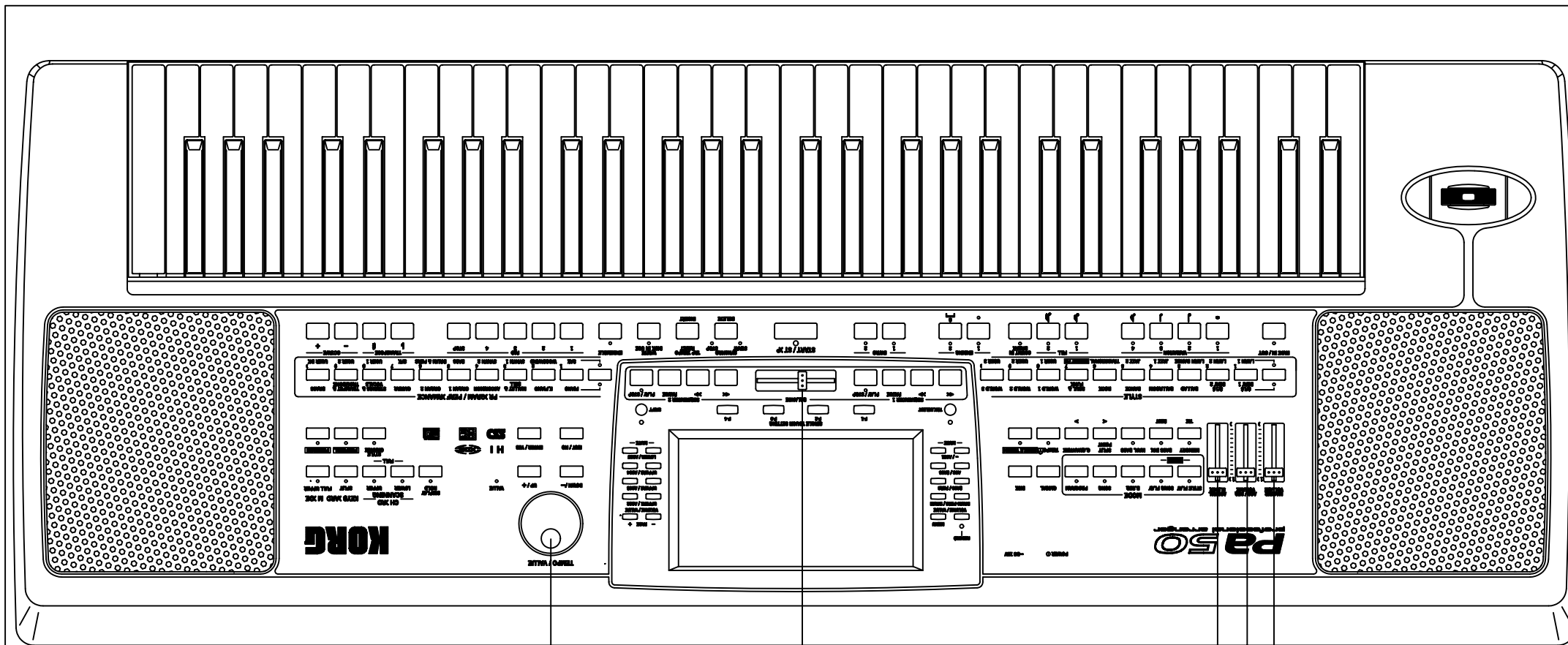

5PPA050UT0L00A0

5PPA050US0L00A0

Remove the marked screws from the bottom of Pa50 and then lift the upper case to separate it from the lower case and have access inside Pa50.

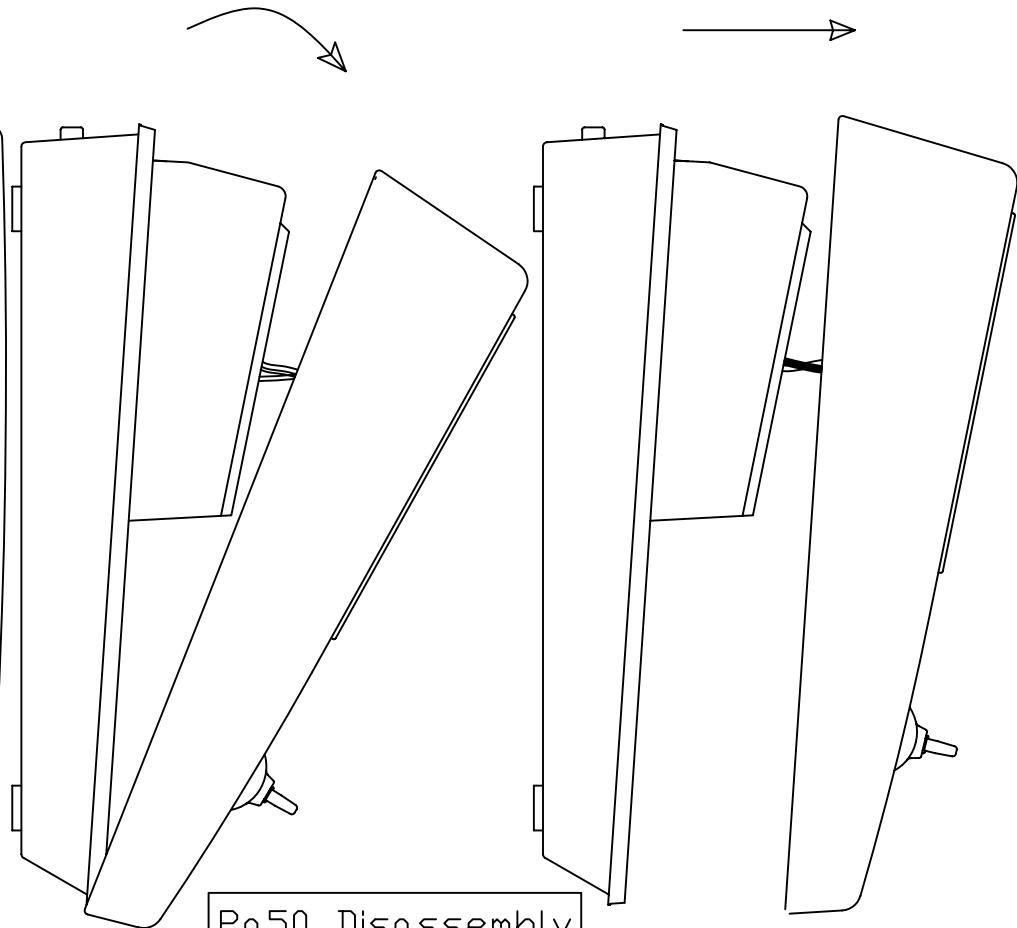
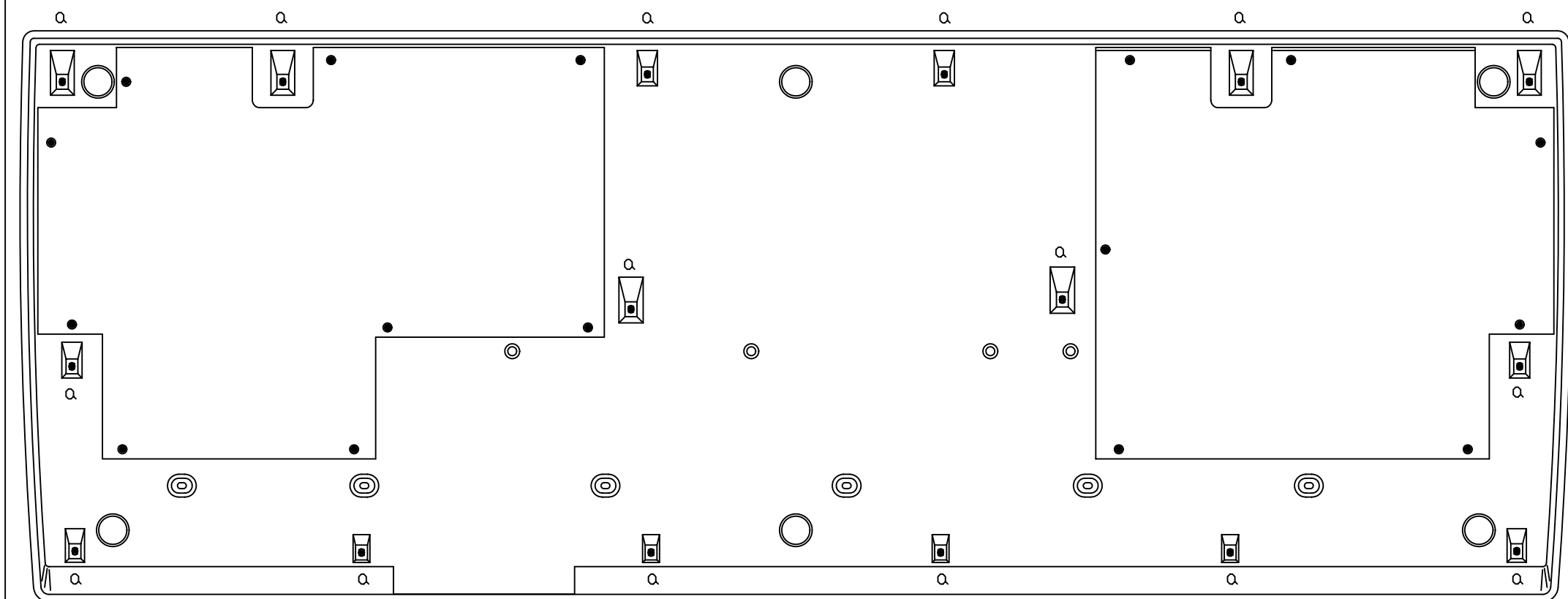

Pa50 Disassembly

j	5SBXM030080C2B0	Screw 3 x8BM	3
i	5SBXM030080C2B0	Screw 3 x8BM	3
Ref.	Code	Description	Q.ty

Upper Case Disassembly 1



4HF0F0F26075280 4HF0F0F20110280 Output board 4HF5F5B06710240 3FCC5AT25151200
7FAD1000MM15000 7FIPA050L50MM00

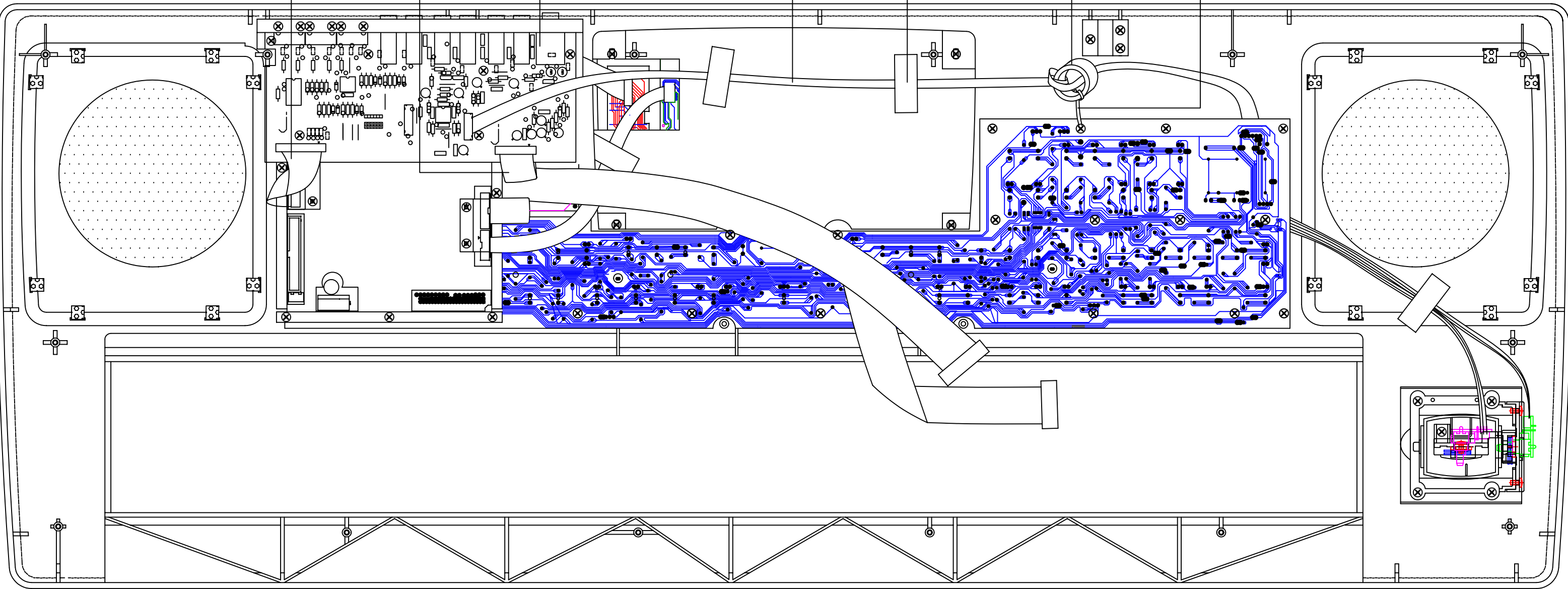

k	5SBXM030060C2B0	Screw 3 x6BM	4
Ref.	Code	Description	Q.ty

Upper Case Disassembly 2

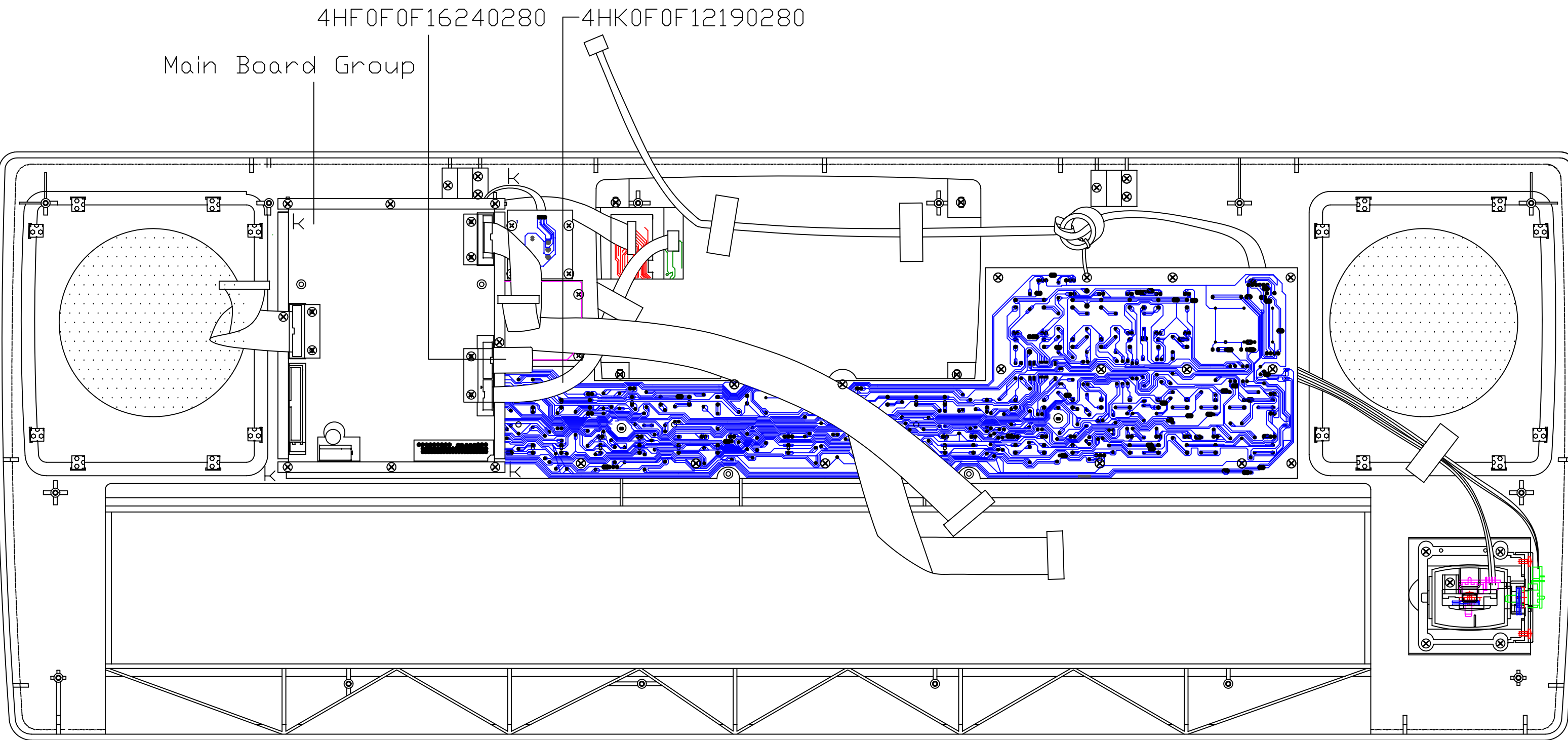

Upper Case Disassembly 3

m	5SBXB026080D2B2	Screw 2.6 x8BB	34
l	5SBXB026080D2B2	Screw 2.6 x8BB	4
Ref.	Code	Description	Q.ty

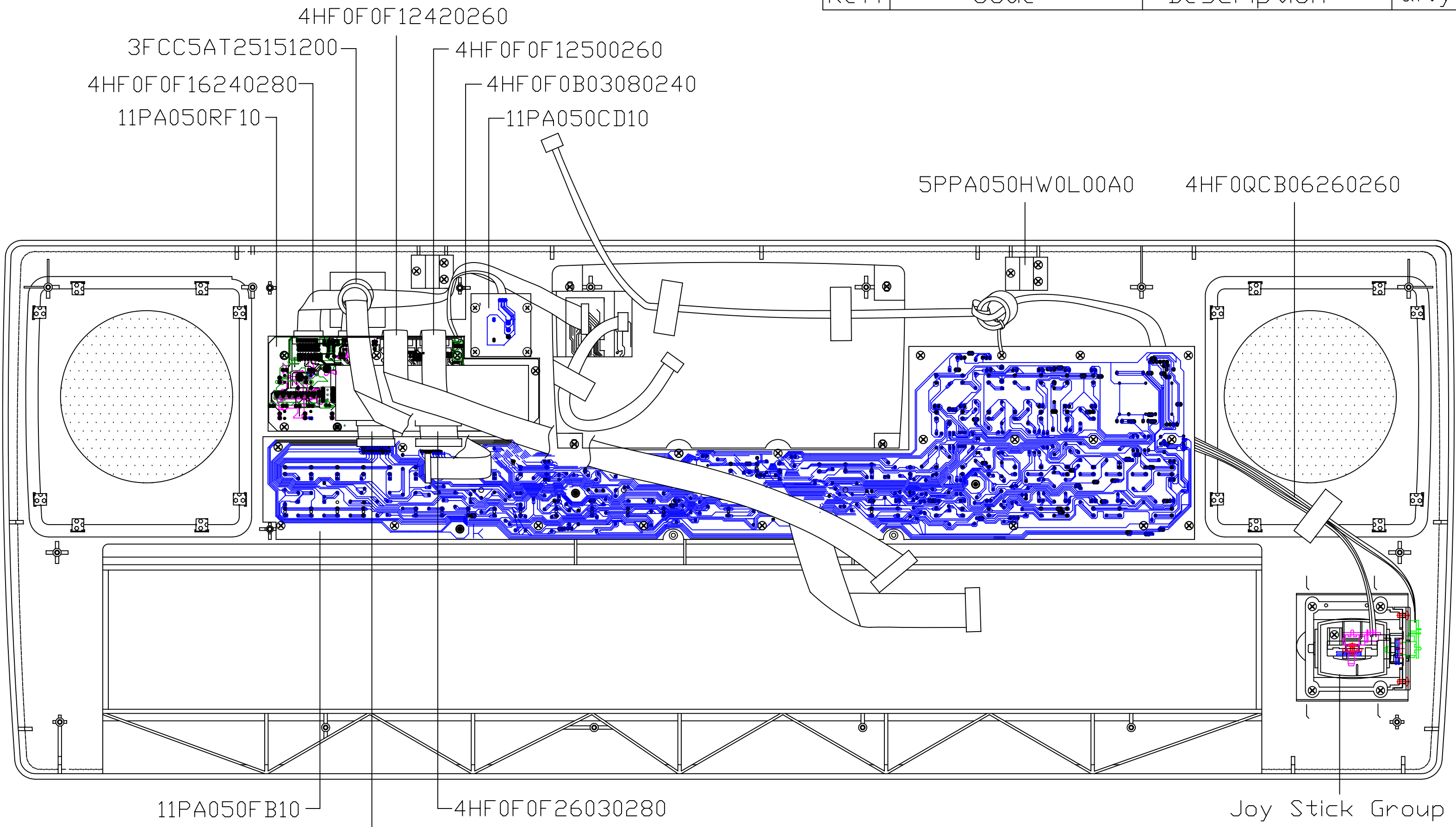

11PA050FB10, 11PA050RF10, 11PA050CD10 are fixed with screws "m".

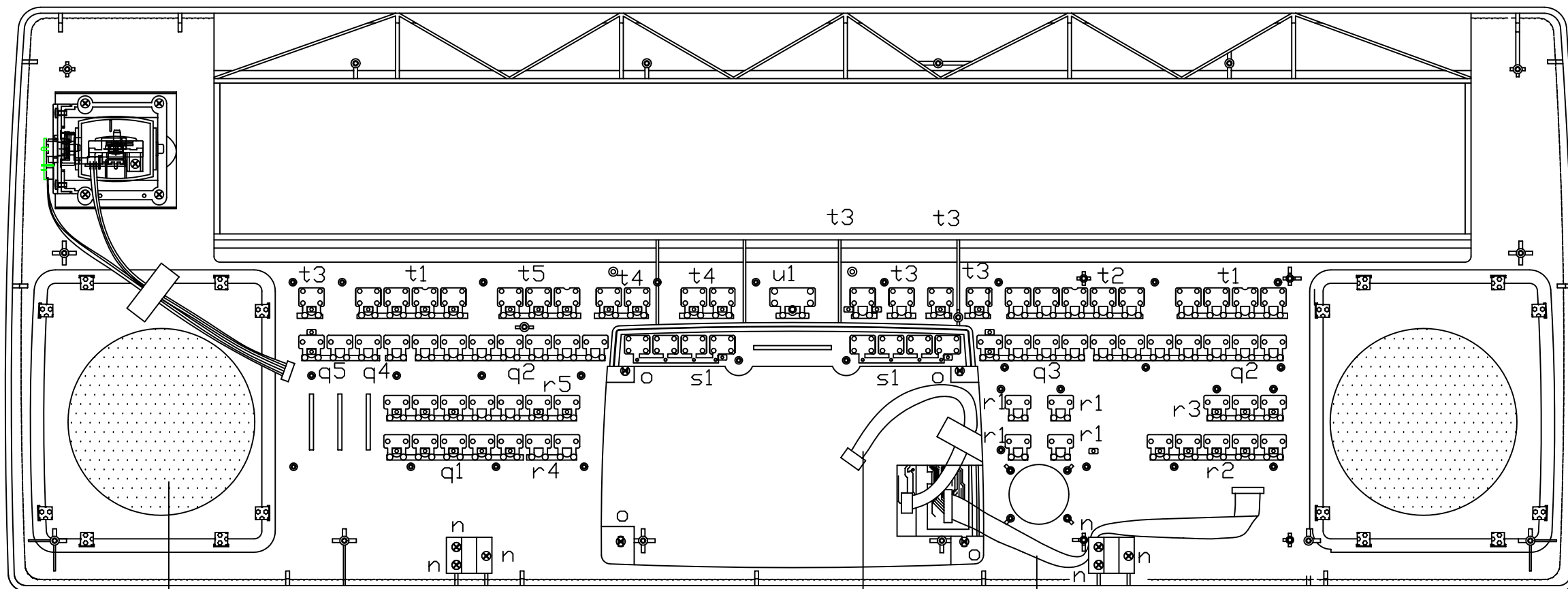

5F S017015300400

4HK0F0F12190280

4HF0F0F16240280

5MPA050NSPA0001

View 1

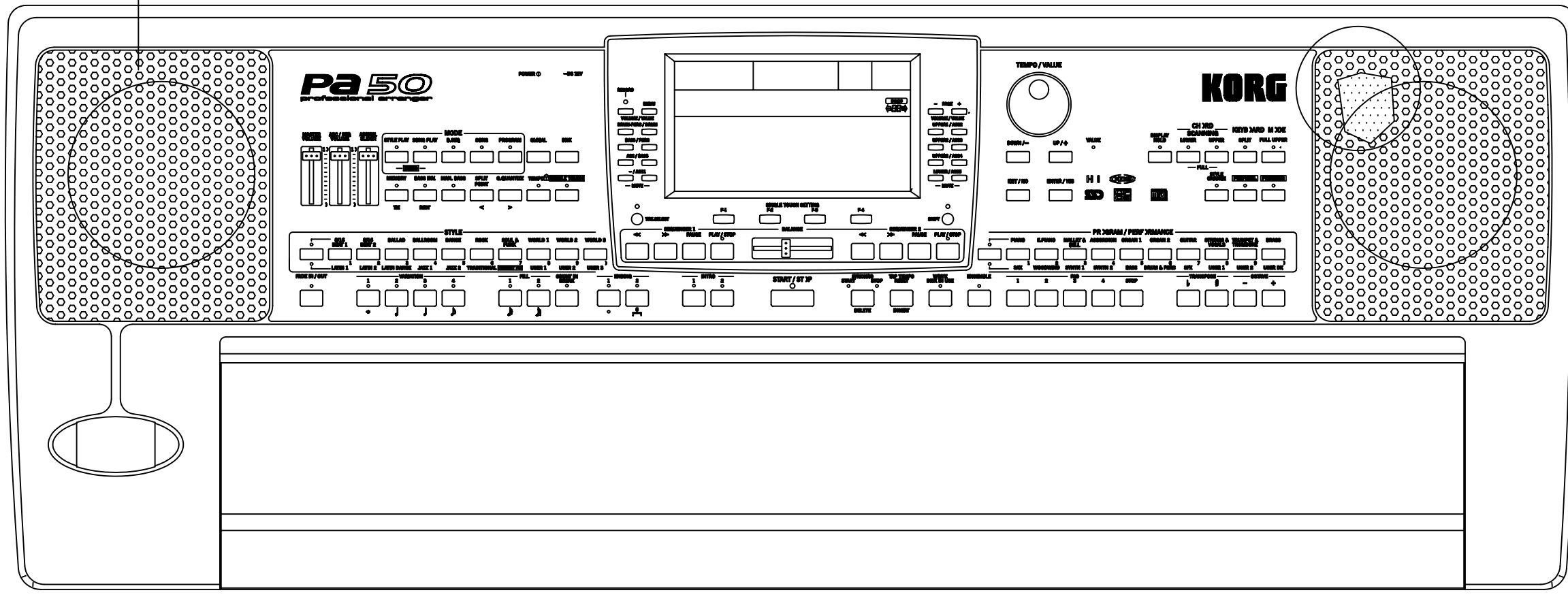

Switch Buttons Setting			
Ref.	Code	Colour	Q.ty
q1	5C002090432UZZ0	GREY	1
q2	5C002090432UZZ0	GREY	2
q3	5C002090432UZZ0	GREY	1
q4	5C002090432UZZ0	GREY	1
q5	5C002090432UZZ0	GREY	1
r1	5C00209BLACKZZ0	BLACK	4
r2	5C00209BLACKZZ0	BLACK	1
r3	5C00209BLACKZZ0	BLACK	1
r4	5C00209BLACKZZ0	BLACK	1
r5	5C00209BLACKZZ0	BLACK	1
s1	5C002070432UZZ0	GREY	2
t1	5SBXB026080D2B2	BLACK	2
t2	5SBXB026080D2B2	BLACK	1
t3	5SBXB026080D2B2	BLACK	5
t4	5SBXB026080D2B2	BLACK	2
t5	5SBXB026080D2B2	BLACK	1
u1	5C002080187UZZ0	RED	1

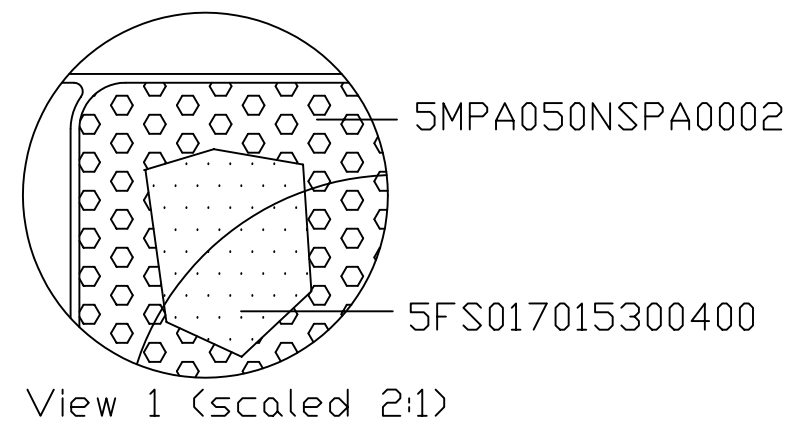

View 1 (scaled 2:1)

o	5SBXB030120B2B0	Screw 3x12BB	4
n	5SBXB026080D2B2	Screw 2.6x8BB	6
Ref.	Code	Description	Q.ty

c	5SBXM030140B2C0	Screw 3 x20PWB	5
b	5SWXB030200B2C0	Screw 3 x12BB	16
Ref.	Code	Description	Q.ty

Lower Case Disassembly 1

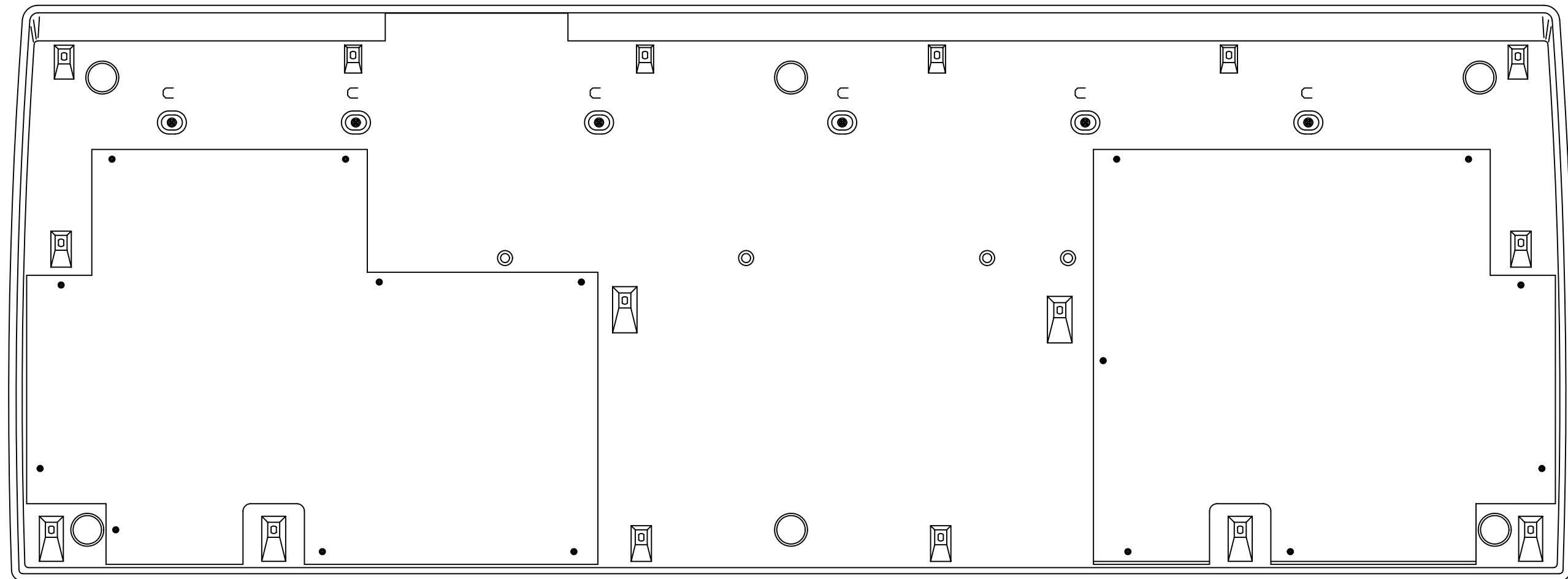
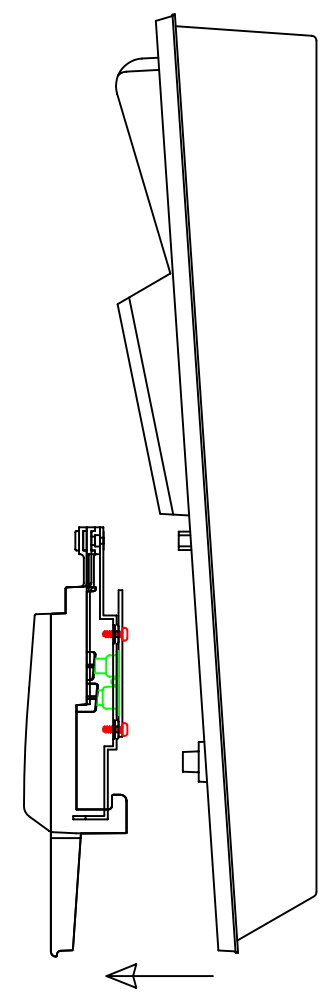
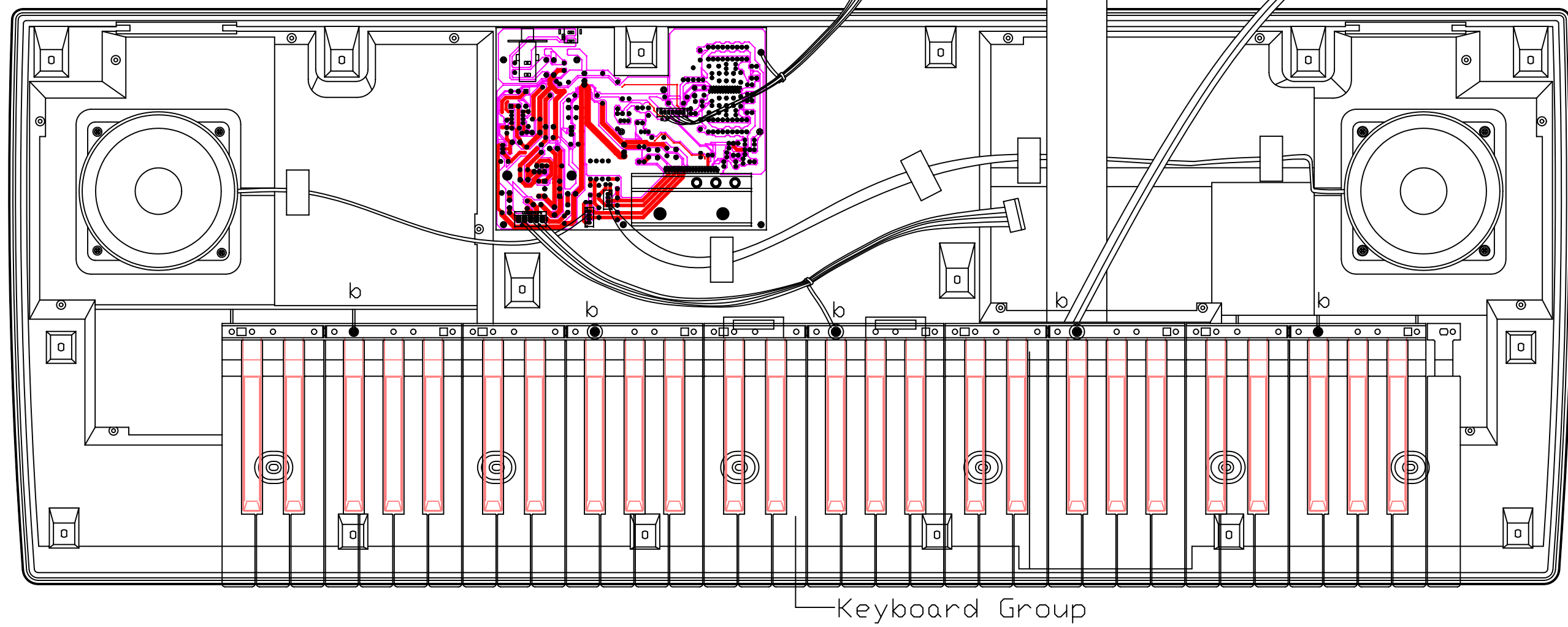

Remove the marked screws from the bottom and then lift the keyboard to separate it from the lower case.

f	5SWXB030080B2B1	Screw 3 x8PWB	4
e	5SBXB026080D2B0	Screw 2.6 x8BB	7
d	5SPXM040120B5B0	Screw 4 x12BB	8
Ref.	Code	Description	Q.ty

Lower Case Disassembly 2

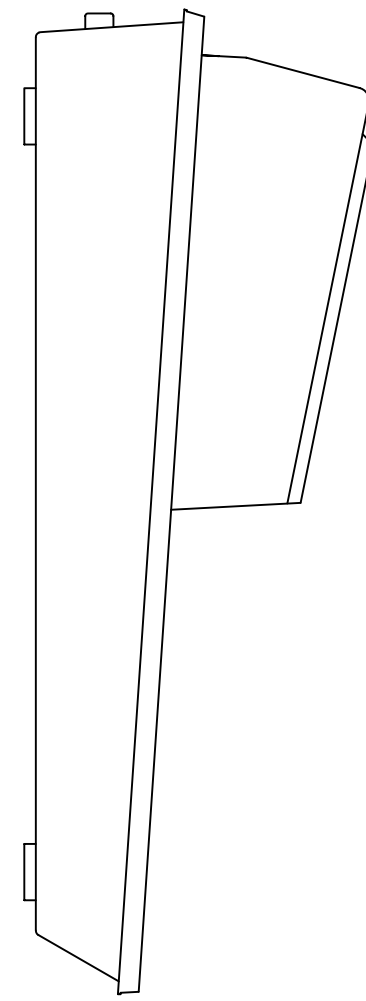
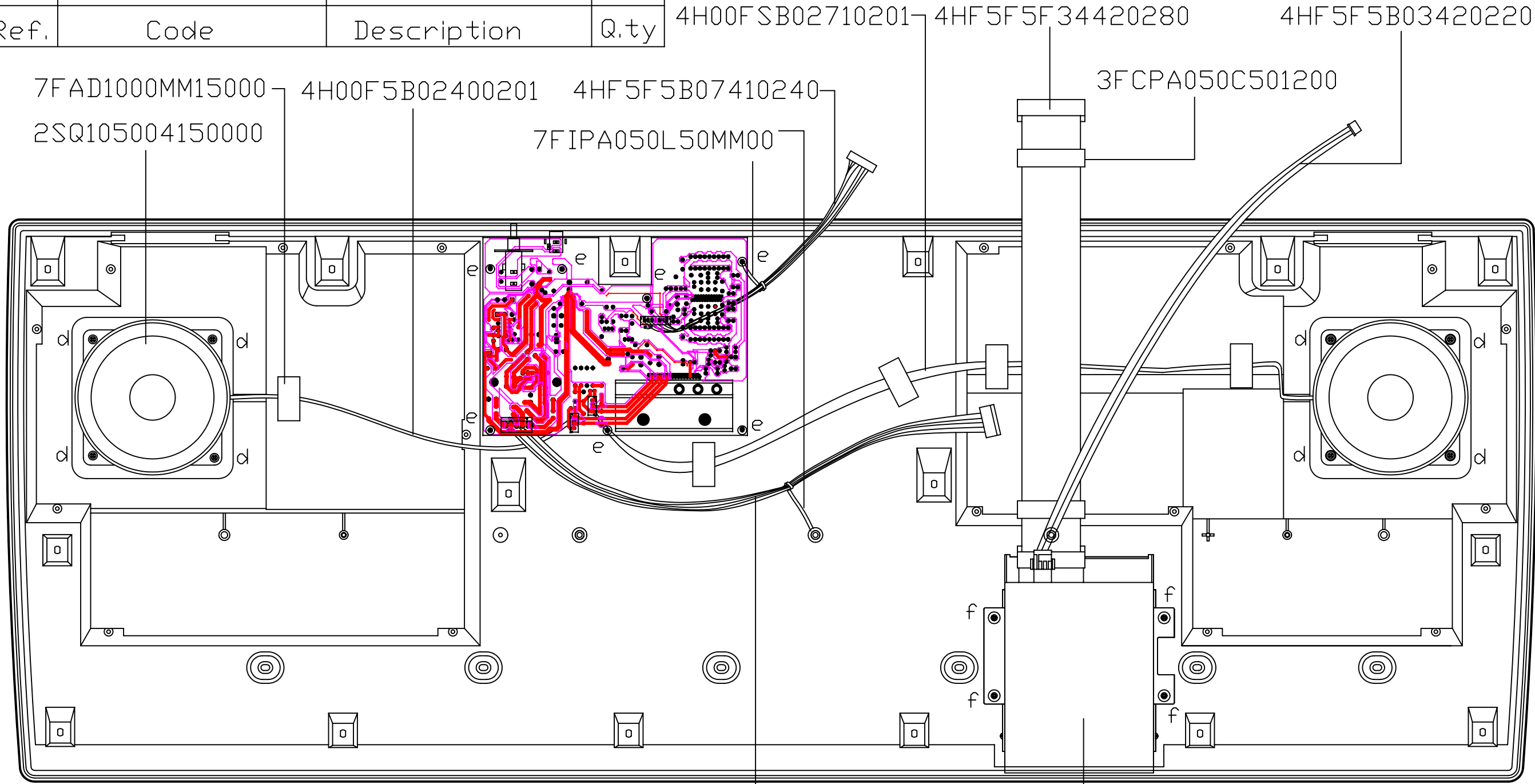

4HF9F9B05600220 Floppy Disk Group

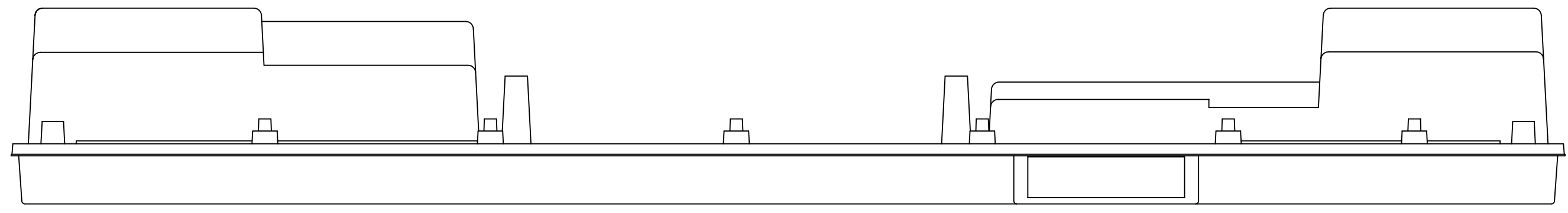

Lower Case Disassembly 3

h	5SWXB030200C2B0	Screw 3 x20PWB	16
g	5SBXB030120B2B0	Screw 3 x12BB	4
Ref.	Code	Description	Q.ty

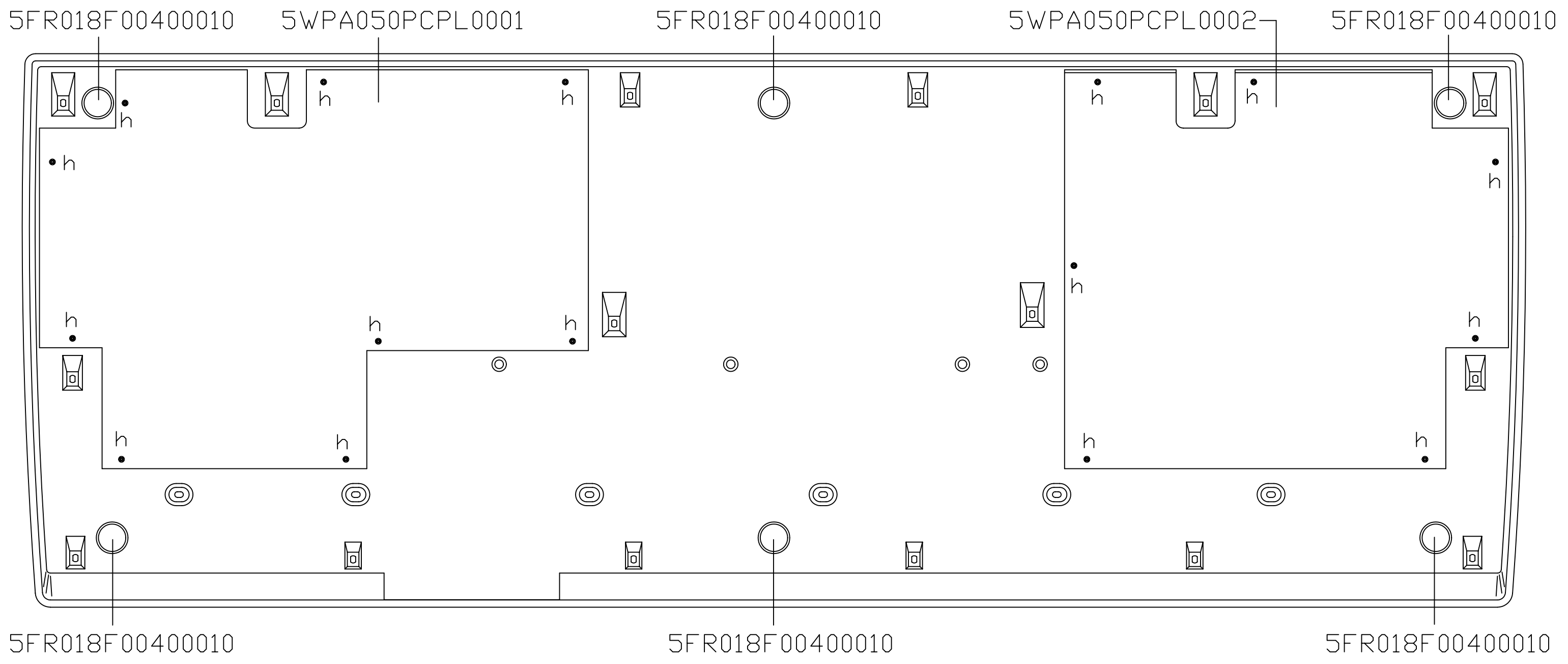
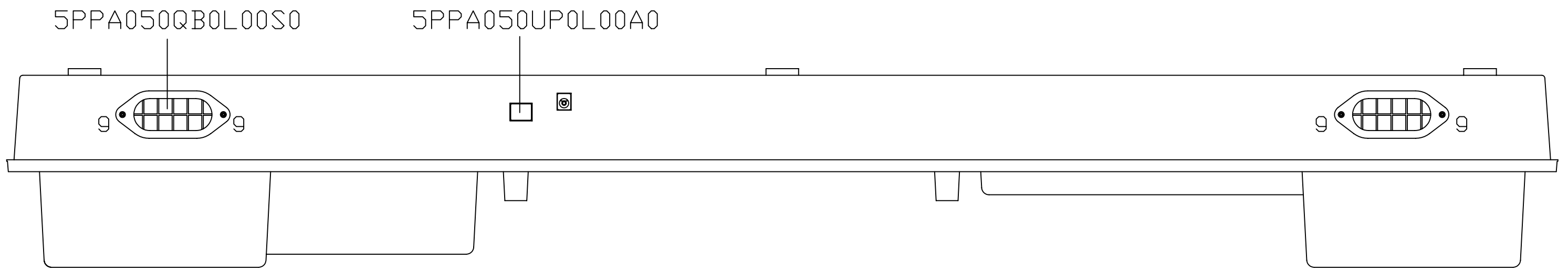

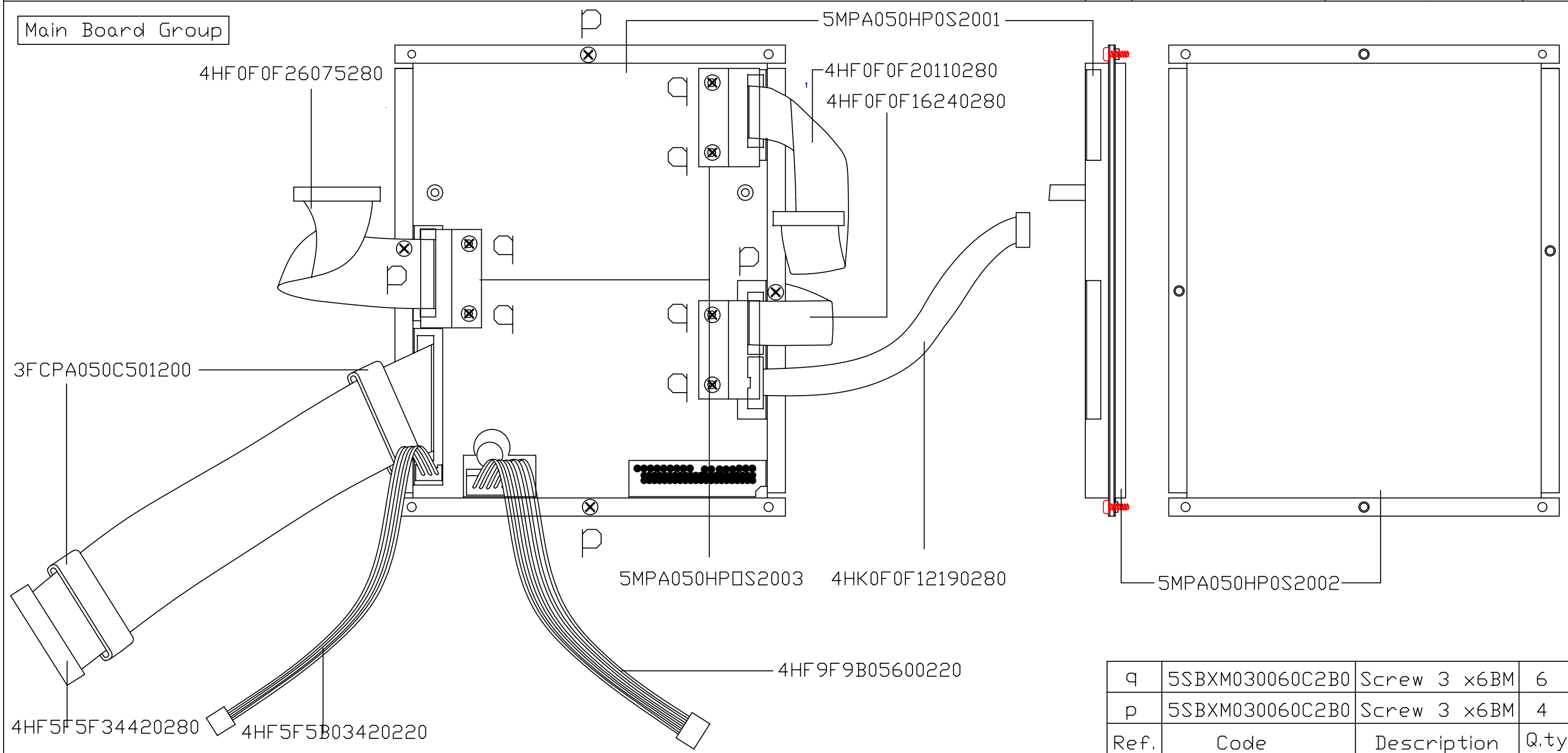
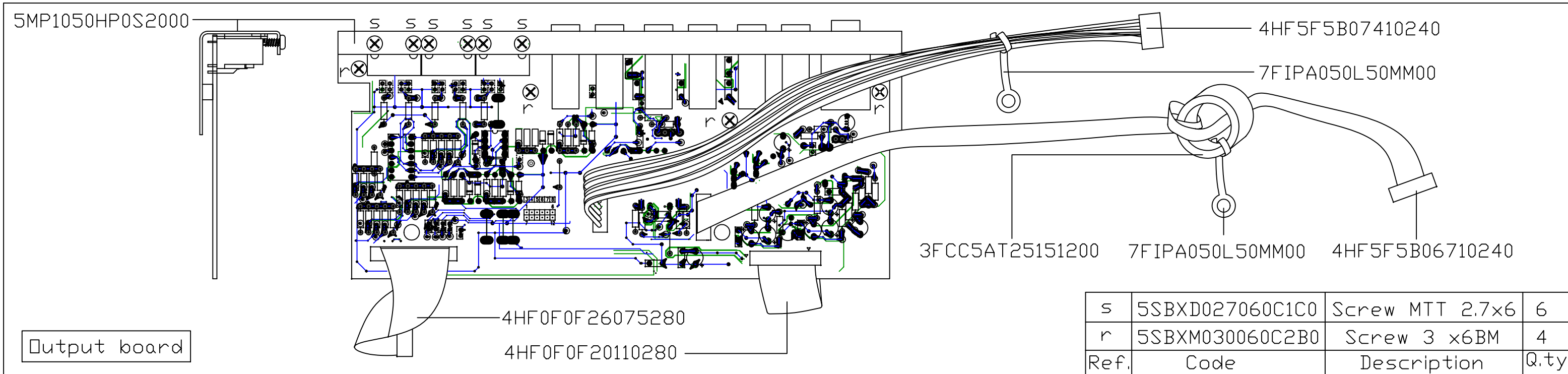

s	5SBXM030060C2B0	Screw 3 x6BM	4
Ref.	Code	Description	Q.ty

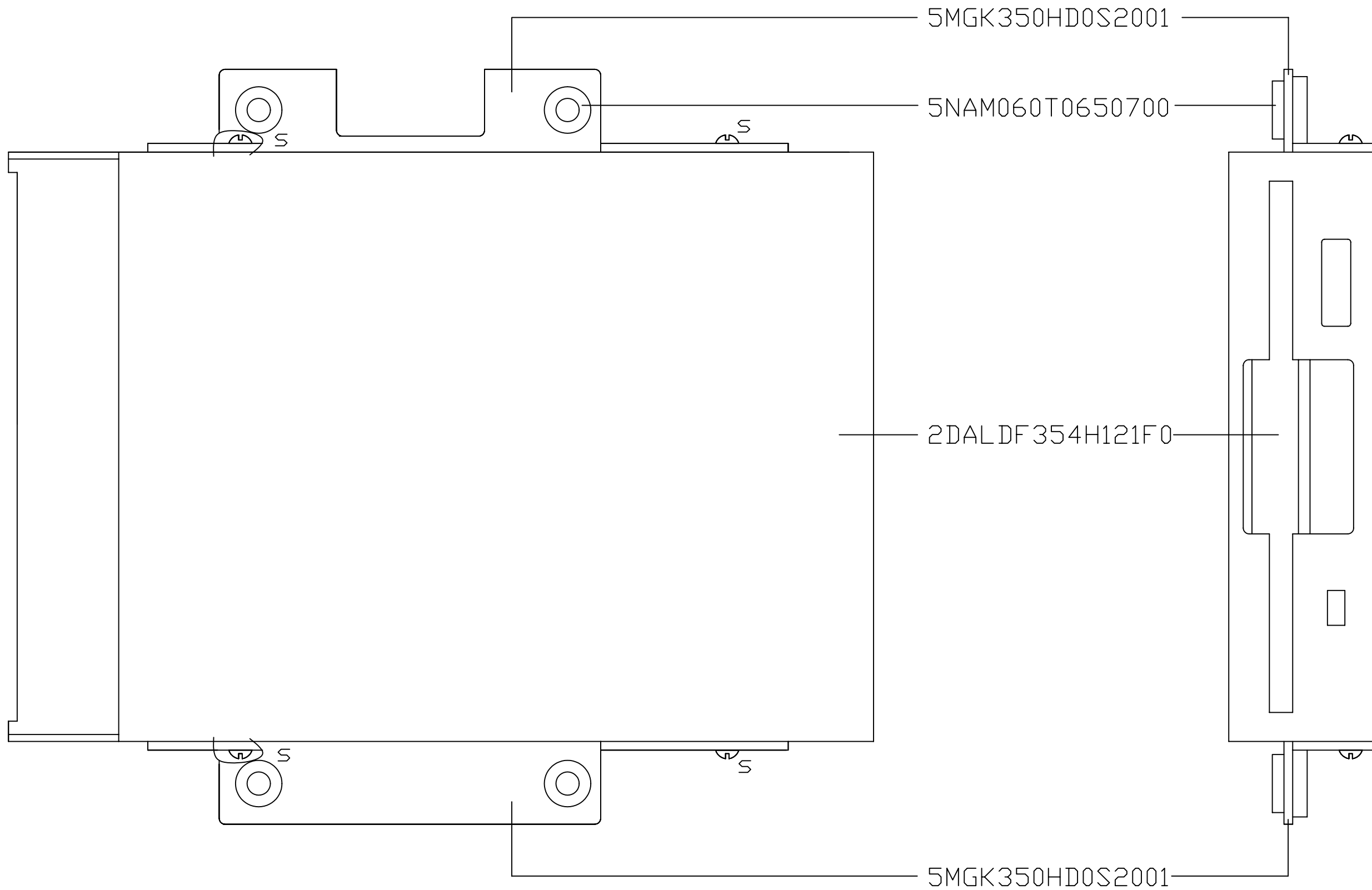

Floppy Disk Group

HARNESSES (FOR Pa50 UNLESS OTHERWISE SPECIFIED)

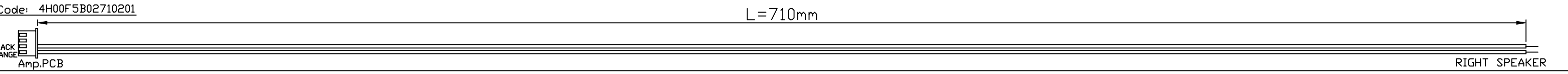
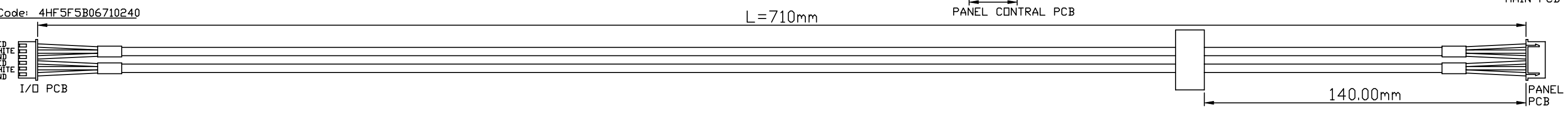
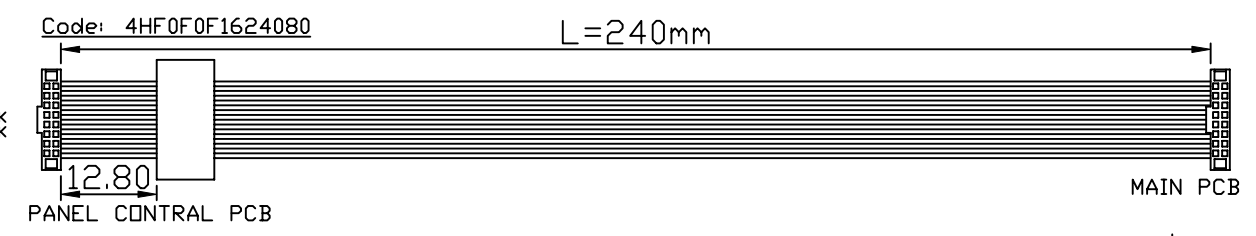
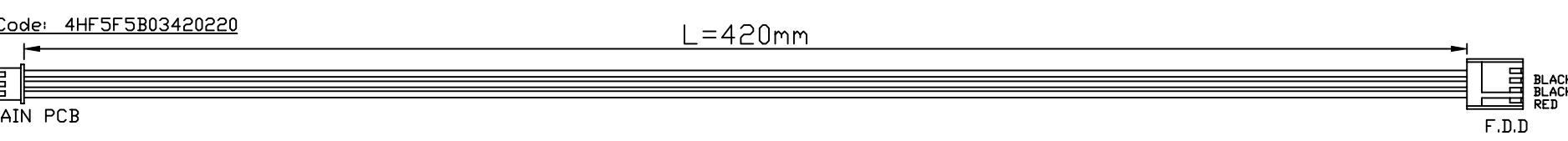
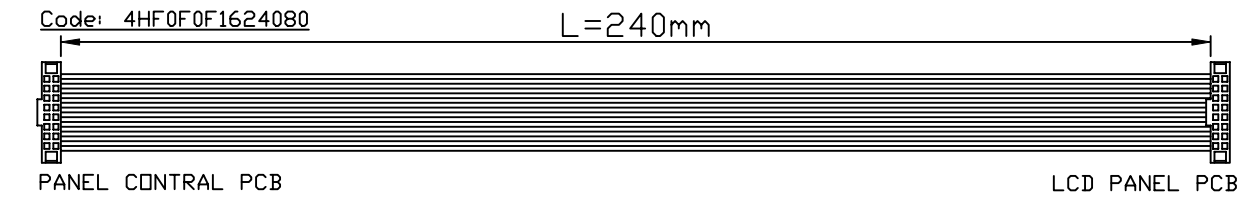
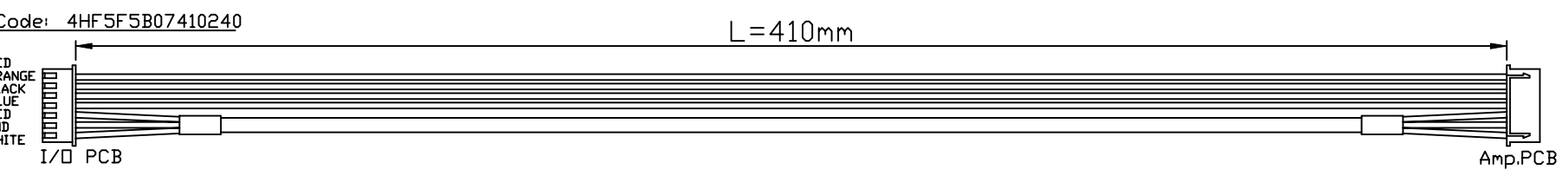
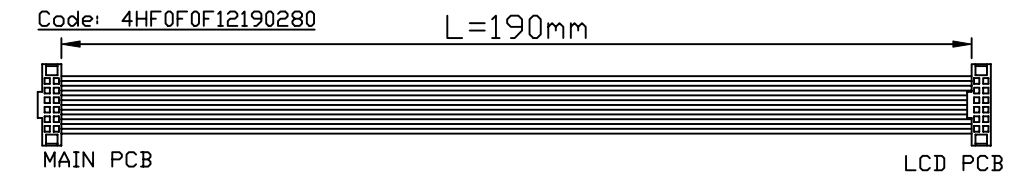
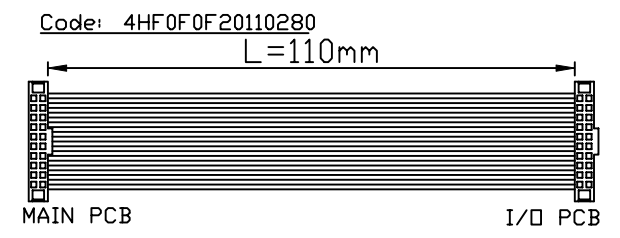
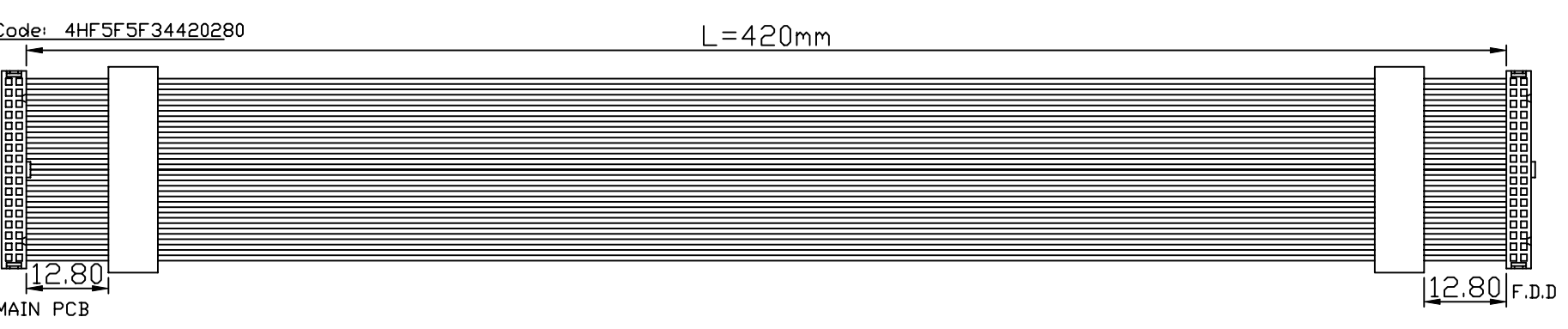
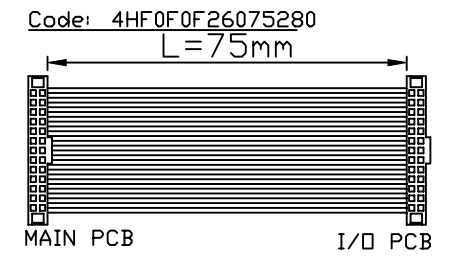
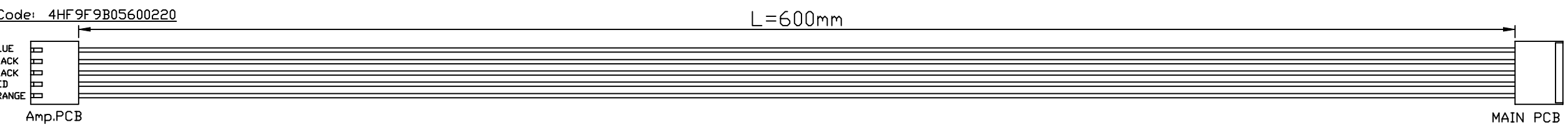
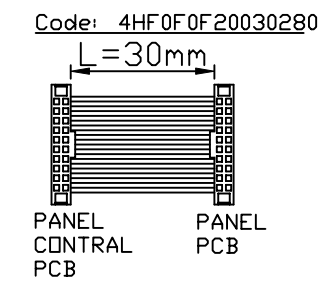
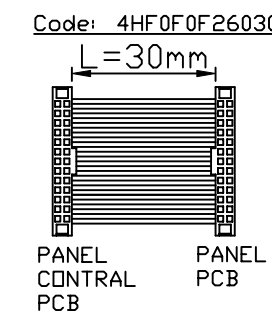
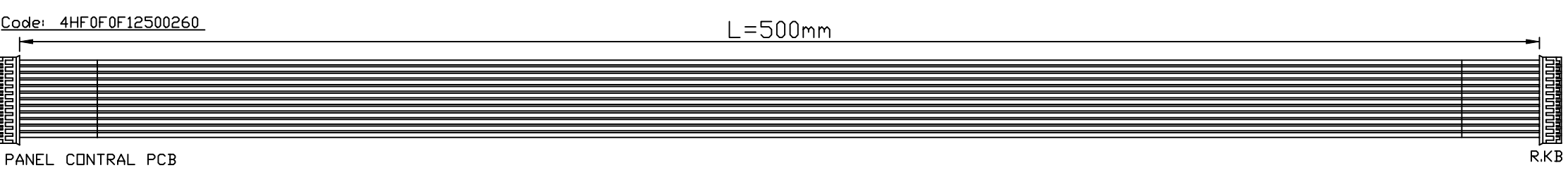
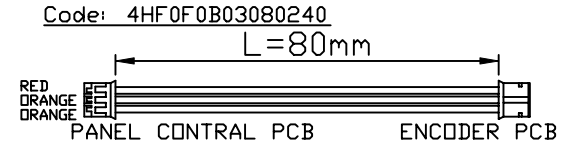
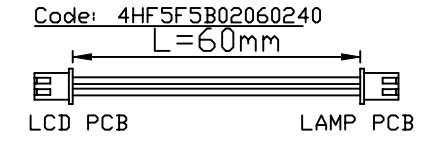
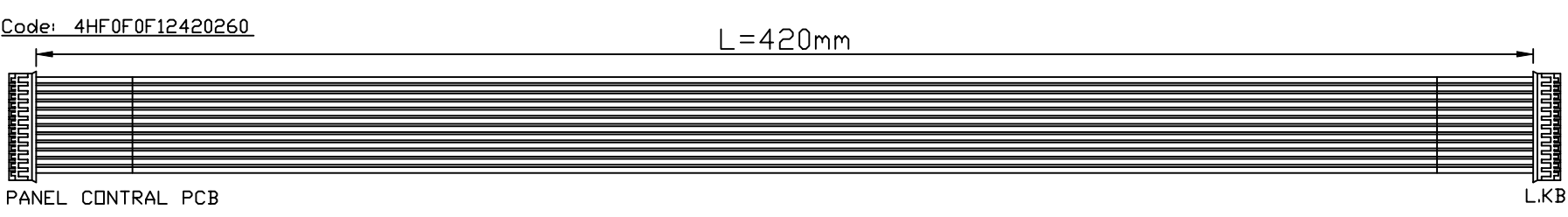
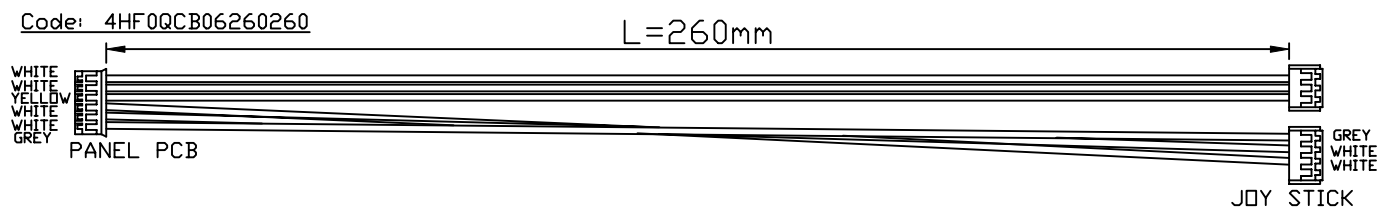
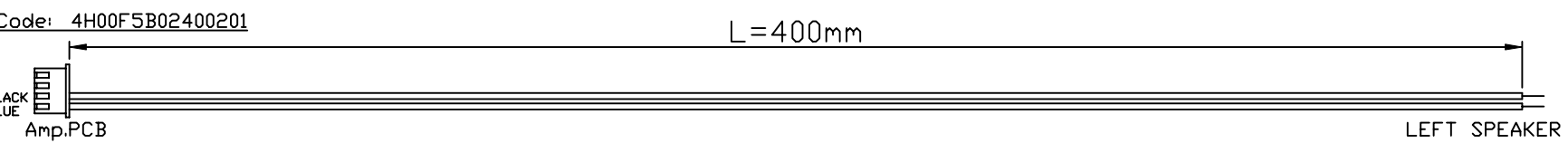

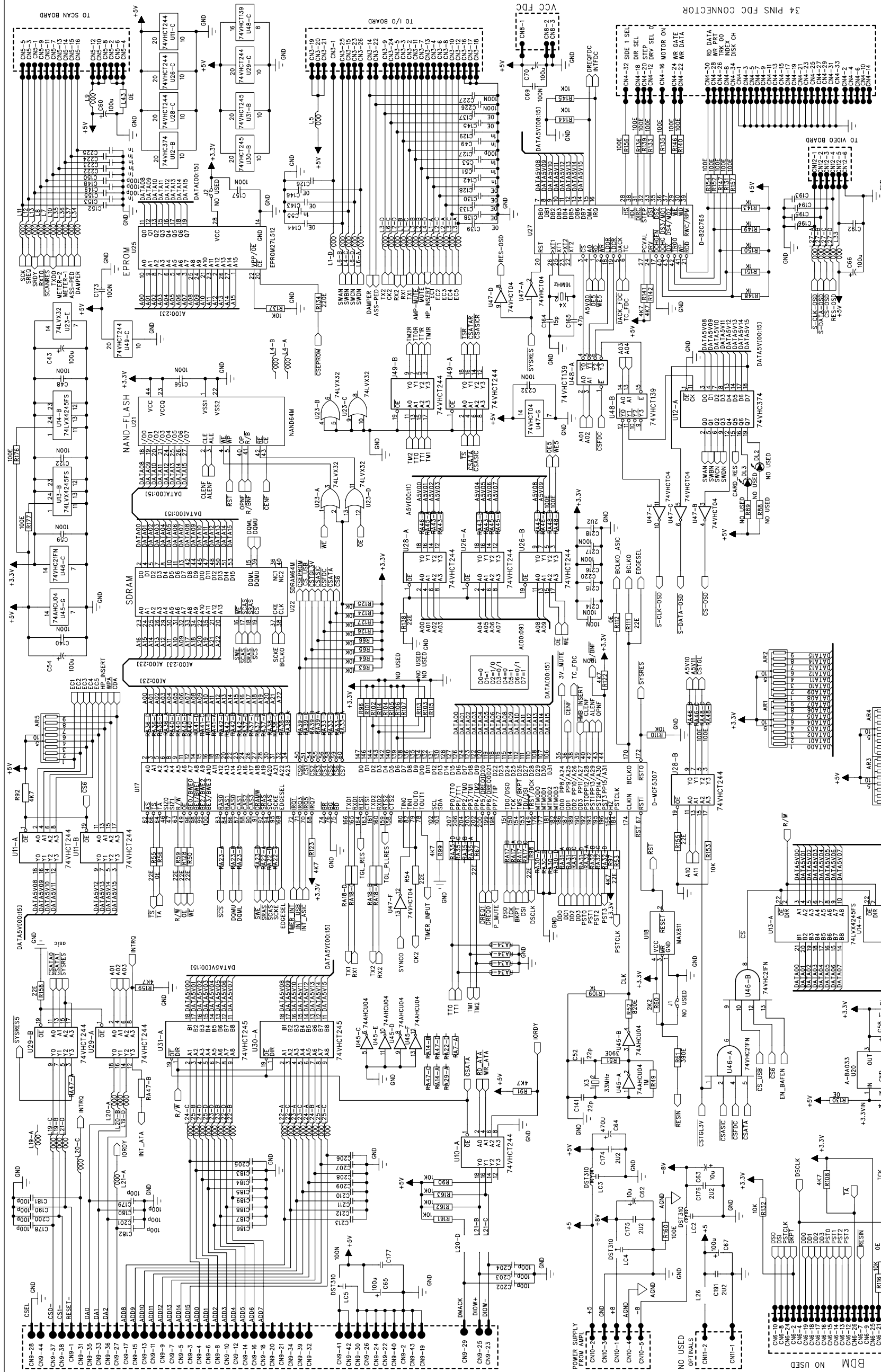

MEDELI	PA50 MAIN BOARD
DATE: 20030422	TITLE: PA50 MAIN BOARD
CHECKED: []	DATE: []
QUALITY CONTROL: []	DATE: []
RELEASED: []	DATE: []
DRAWN NO. PA50-101-301	NAME: MICRO
SHEET 1	OF 3 SHEETS

MEDELI

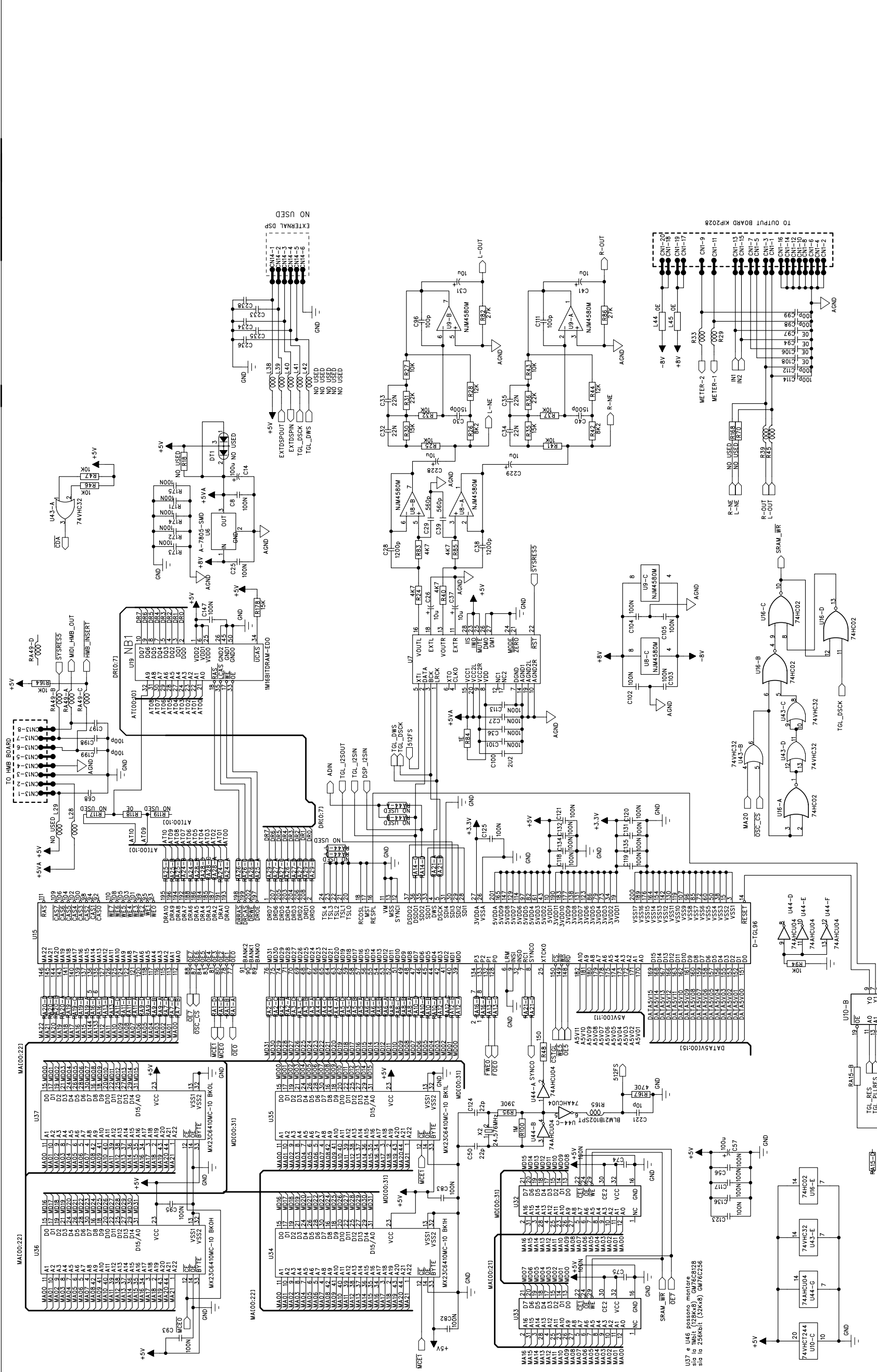

U37 e U46 possono montare
 sia in DIP16 (74VHC244) sia in
 sia in SO16 (74VHC244)

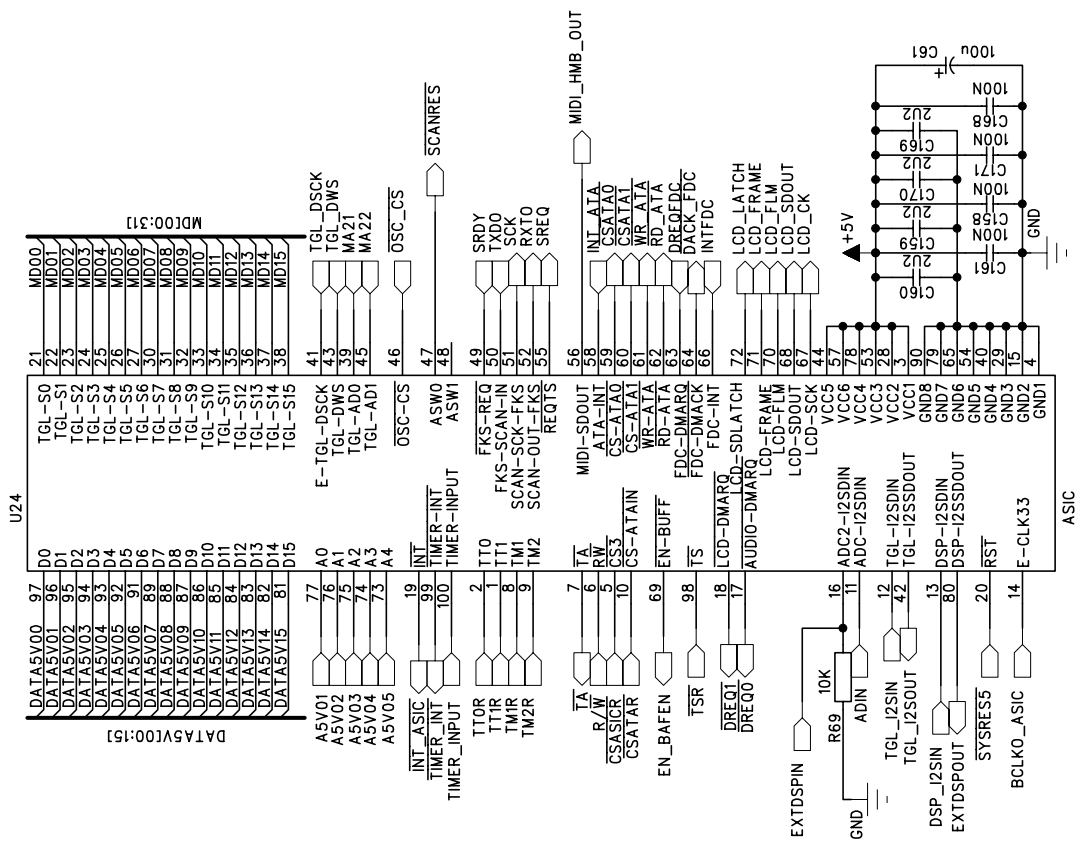

TO LCD

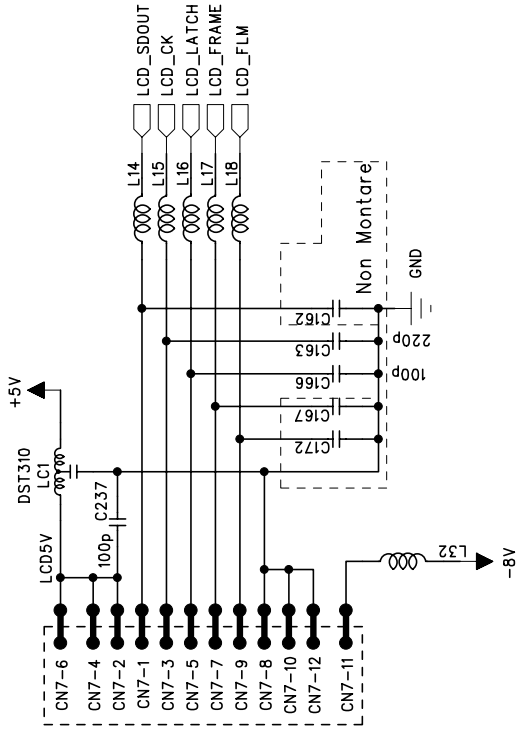

DRAWN NO.		PA50-1101-303	
DRAWN Yuxd		DATE:20030422	
CHECKED	DATE	TITLE	
QUALITY CONTROL	DATE	PA50 MAIN BOARD	
RELEASED	DATE	SIZE	A4
		SHEET	3
		OF	3 SHEETS

MEDELI

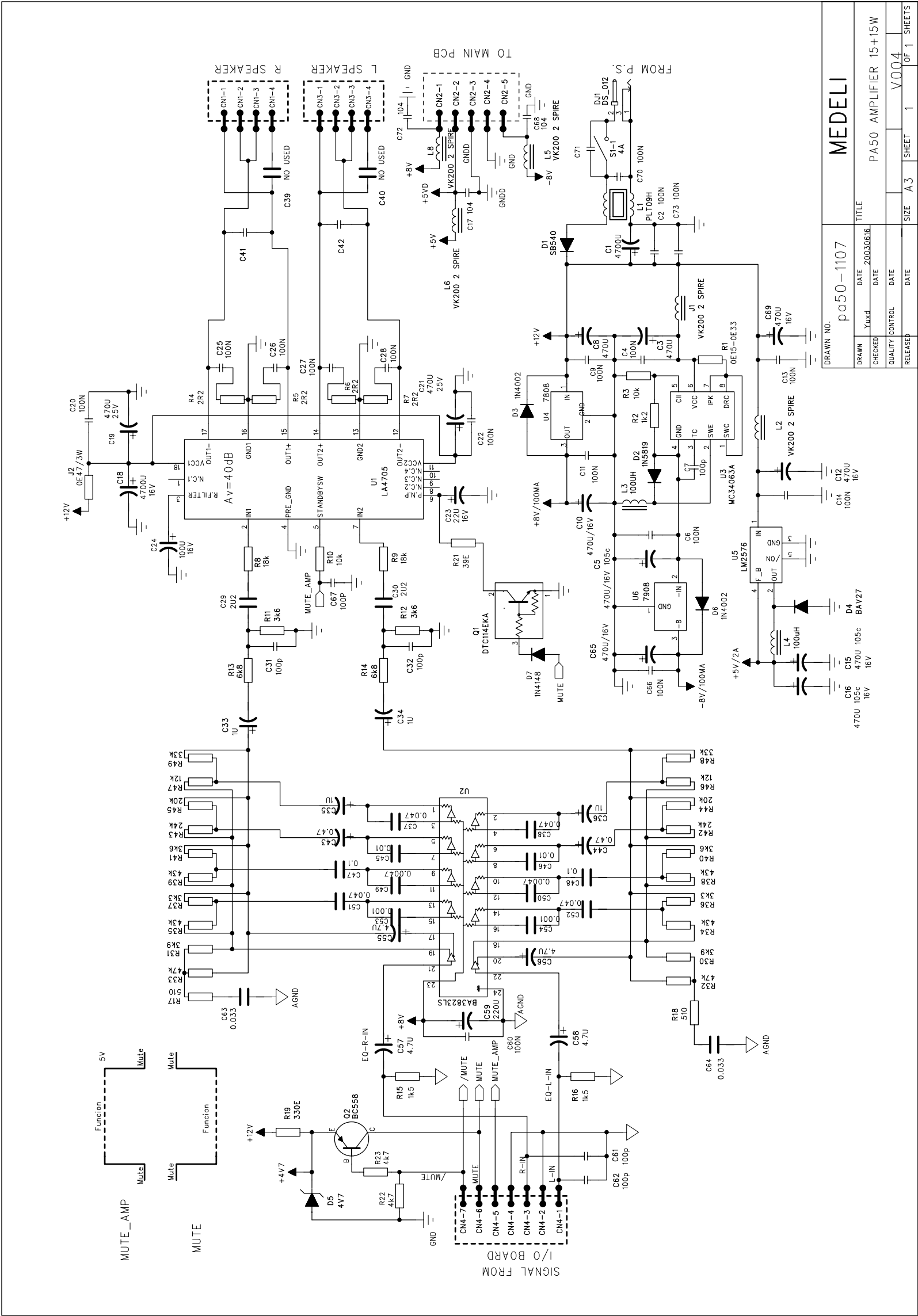

DRAWN NO.		pa50-1107	
TITLE		MEDELI	
DRAWN	DATE	CHECKED	DATE
	Yujid		20030616
QUALITY CONTROL	DATE	RELEASED	DATE
SIZE	A3	SHEET	1
OF		SHEETS	1

PA50 AMPLIFIER 15+15W

DRAWN	DATE	CHECKED	DATE
	Yujid		20030616
QUALITY CONTROL	DATE	RELEASED	DATE
SIZE	A3	SHEET	1
OF		SHEETS	1

REVISION RECORD		
LTR	ECO NO:	APPROVED:

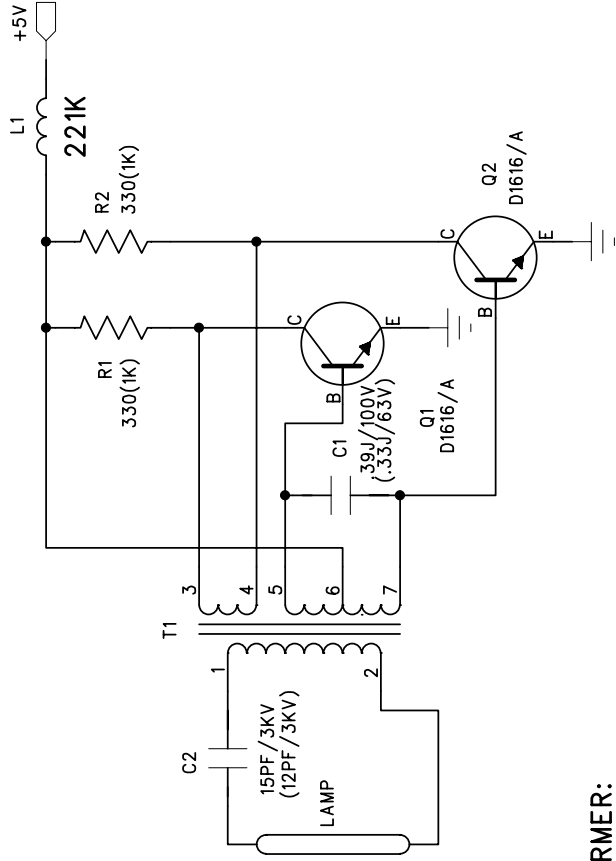

TRANSFORMER:
 EE19/12P-GS-1336THF
 GOLDSUPER INDUSTRY DEVE.CO.,LTD.
 0755-83301497

COMPANY: **Medeli Electronics Co.Ltd**

TITLE: **PA50 LAMPER DRIVER BOARD**

DRAWN: Yuxd	DATED: 2003/03/03
CHECKED:	DATED:
QUALITY CONTROL:	DATED:
RELEASED:	DATED:

CODE:	SIZE: A4	DRAWING NO: PA50-1108	REV: 002
-------	-----------------	------------------------------	-----------------

SCALE: SHEET: **1** OF **1**

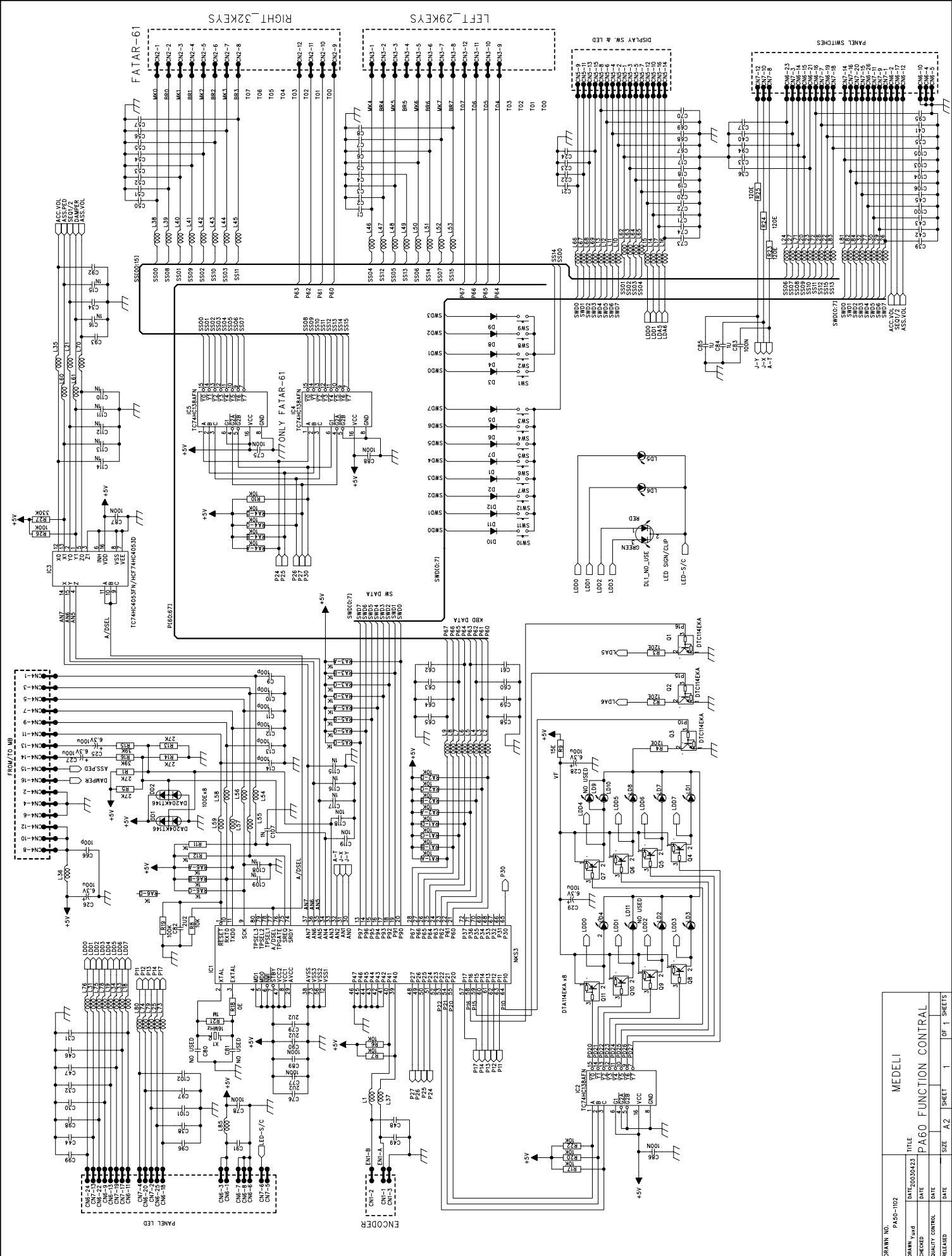

DRAWN NO.	PAGO-102
DATE	1975-03-03
CHECKED	
QUALITY CONTROL	
RELEASED	
MEDELI	
PAGO FUNCTION CONTRAL	
DATE	
SIZE	A2
SHEET	1
OF	1
SHEETS	

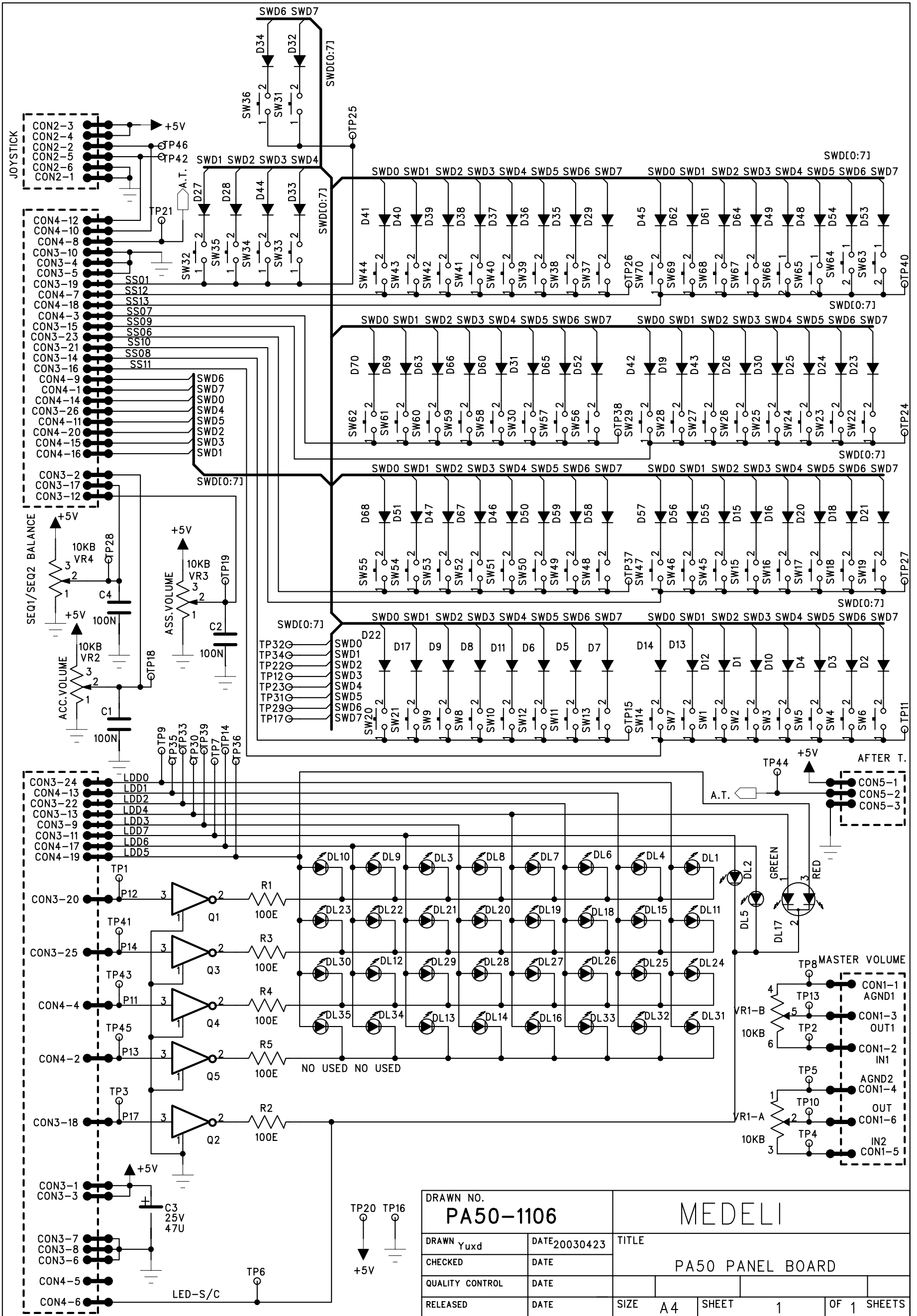

DRAWN NO. PA50-1106		MEDELI	
DRAWN Yuxd	DATE 20030423	TITLE	
CHECKED	DATE	PA50 PANEL BOARD	
QUALITY CONTROL	DATE	SIZE	A4
RELEASED	DATE	SHEET	1
		OF	1 SHEETS

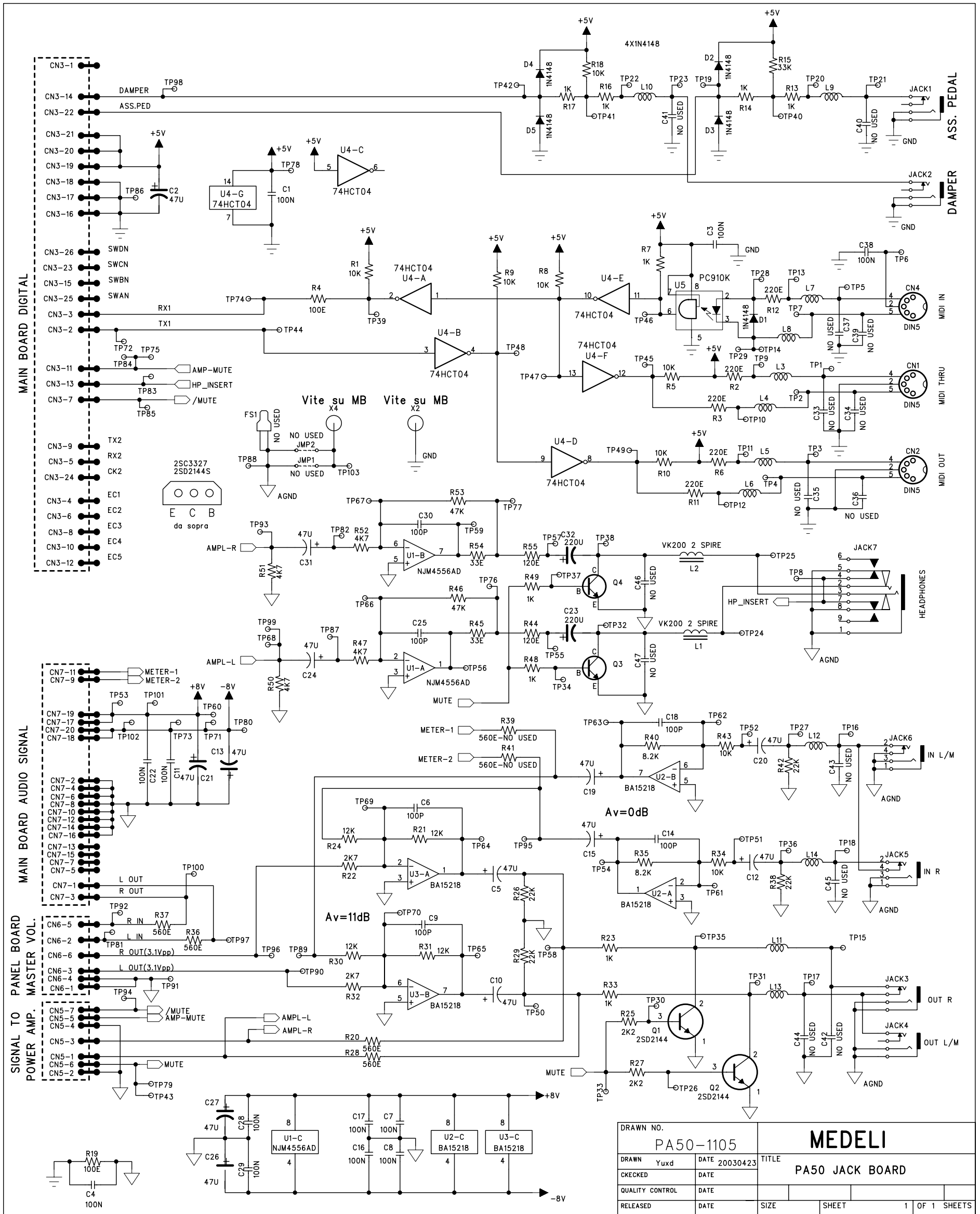

DRAWN NO. PA50-1105		TITLE MEDELI	
DRAWN Yuxd	DATE 20030423	PA50 JACK BOARD	
CHECKED	DATE		
QUALITY CONTROL	DATE		
RELEASED	DATE	SIZE	SHEET 1 OF 1 SHEETS

REVISION RECORD		
LTR	ECO NO:	APPROVED:

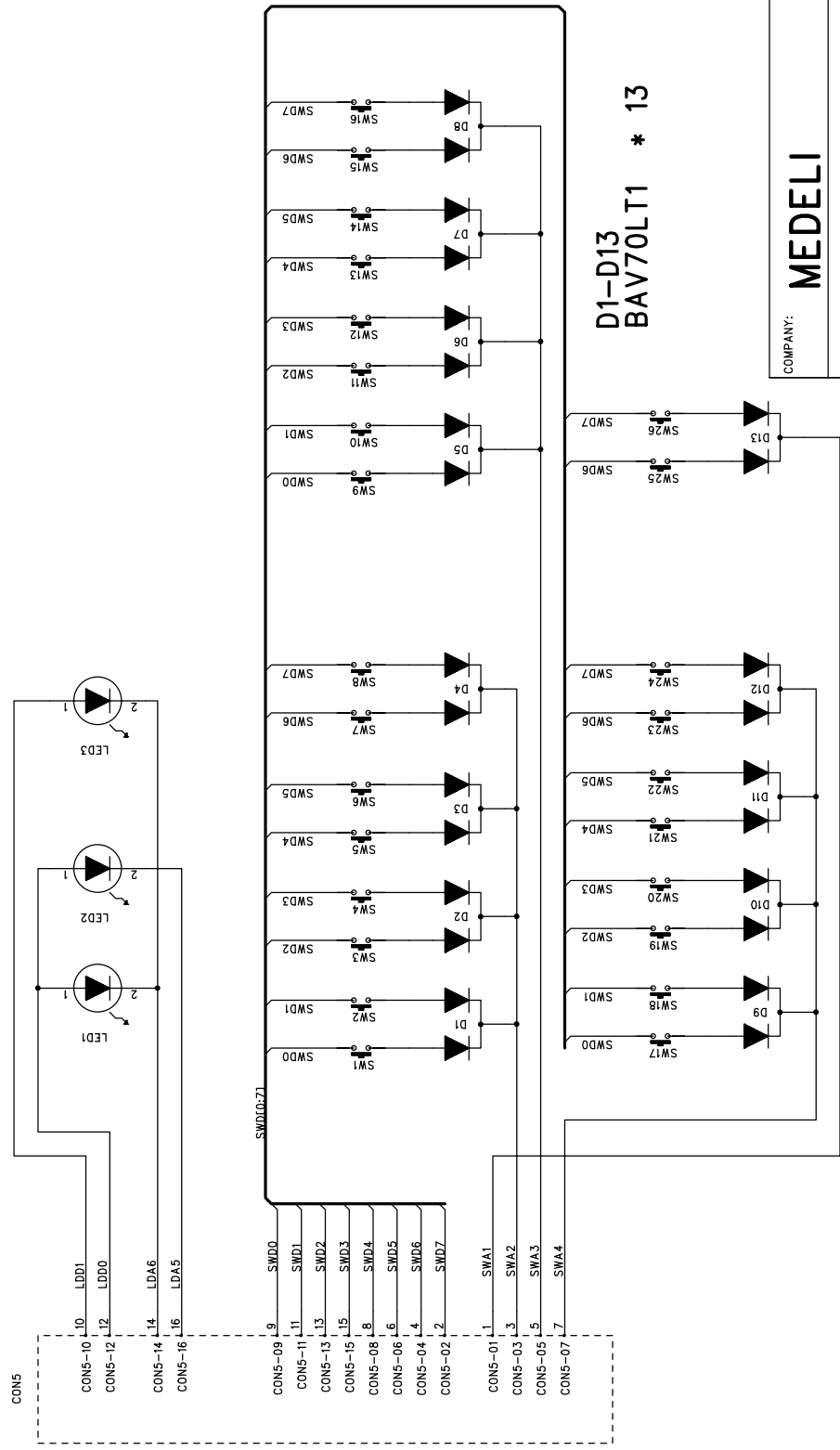

COMPANY: MEDELI	
TITLE: PA50 LCD PANEL CONTROL BOARD	
DRAWN: Yuxd	DATED: 2003/03/03
CHECKED:	DATED:
QUALITY CONTROL:	DATED:
RELEASED:	DATED:
CODE: A3	DRAWING NO: PA50-1104
SCALE:	REV: 001
SHEET: 1	OF 1

REVISION RECORD	
LTR	ECO NO:
	APPROVED:
	DATE:

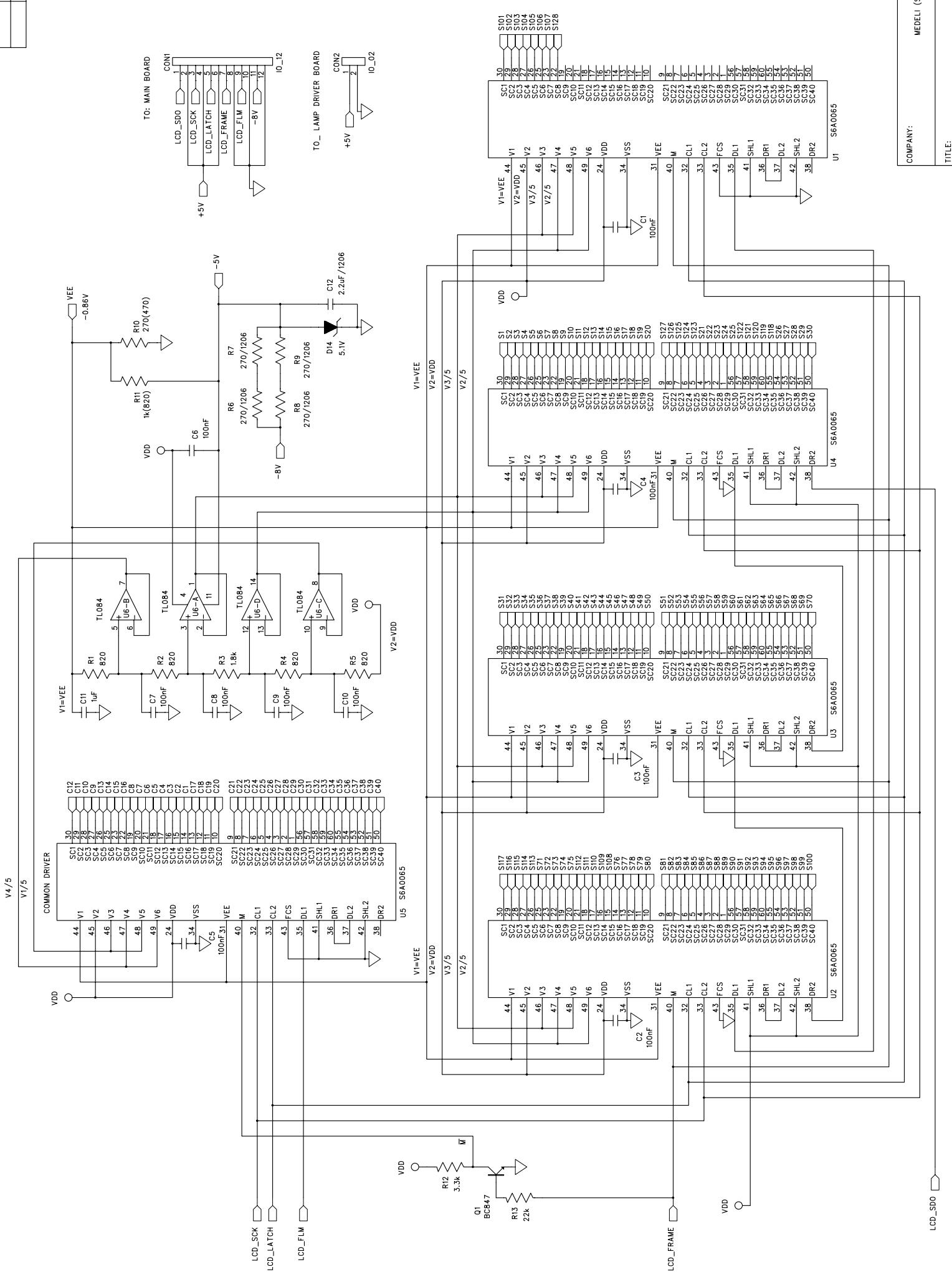

COMPANY: MEDELI (SHENZHEN) CO. LTD.	
TITLE: PA50 LCD BOARD	
DRAWN: Yuxd	DATE: 2003/03/03
CHECKED:	DATE:
QUALITY CONTROL:	DATE:
RELEASED:	DATE:
CODE:	SIZE: A2
DRAWING NO: PA50-1103	
REV: 002	
SCALE:	SHEET: 1 OF 1

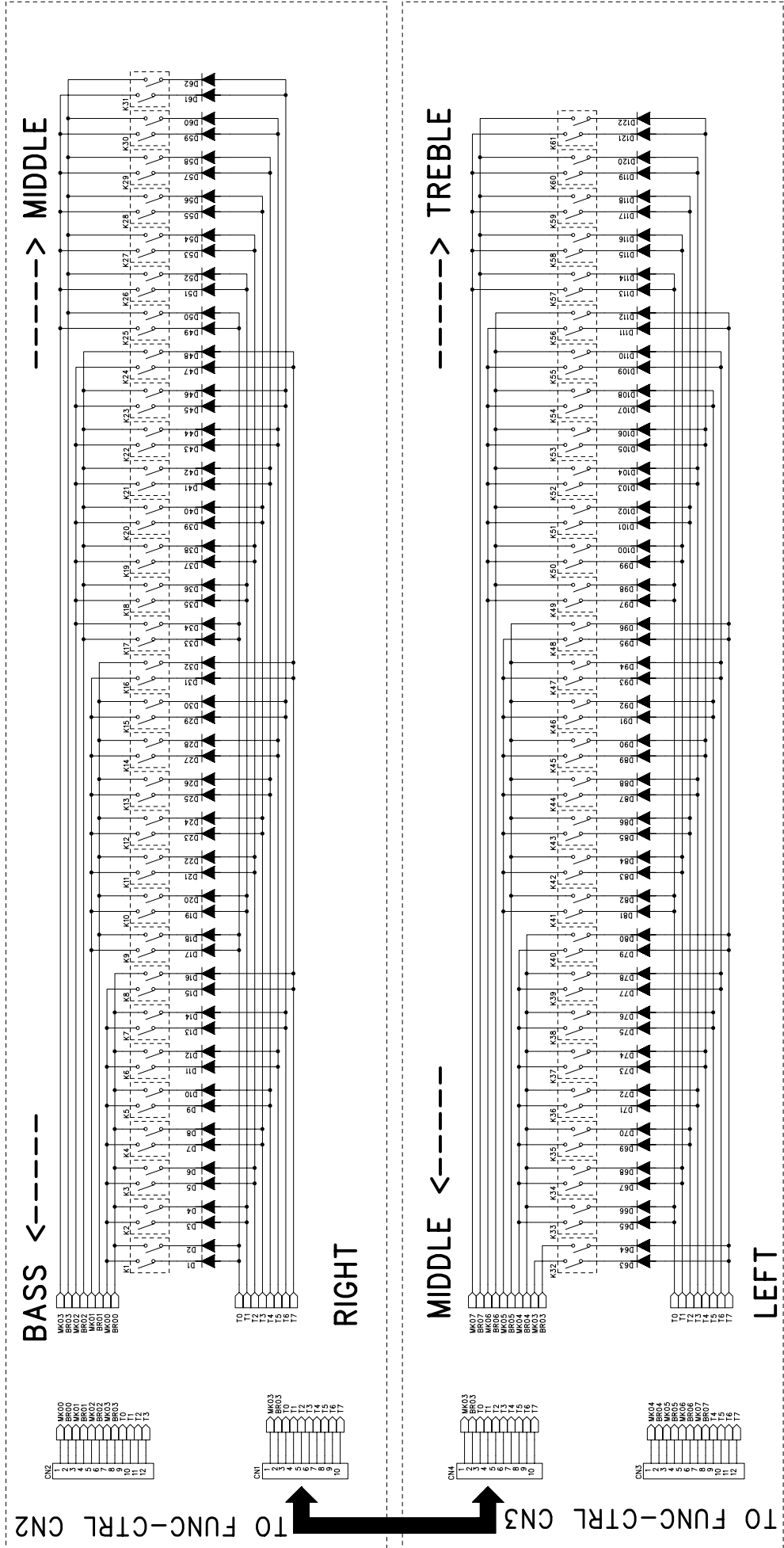

COMPANY: MEDELI ELECTRONICS CO.,LTD

DRAWN: Yuxd		DATED: 02_08_02	
CHECKED:	DATE:	SIZE: A3	DRAWING NO: PA50-1109
APPROVED:	DATE:	REV: 1	
RELEASED:	DATE:	SCALE: 1 OF 1	

61 Keyboard circuit

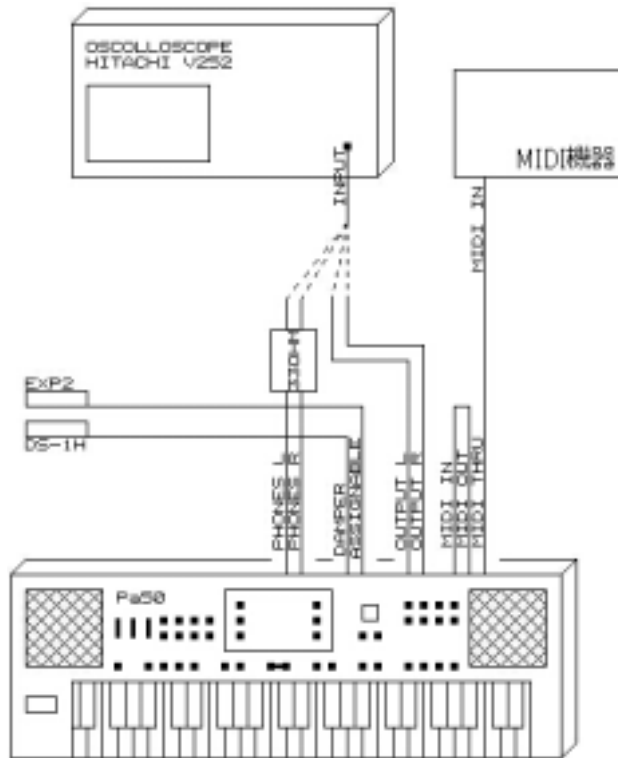
<Preparation for Inspection>*** Connection****Standard Measuring Equipments**

Hitachi V252 20MHz OSCILLOSCOPE.

Floppy Disk Formatted

MIDI Equipment for MIDI Test

MIDI Cable

33ohm Load Cable

Dummy Plug

Damper Pedal KORG DS1H

Assignable Pedal KORG EXP2

33ohm Cable connects to Phone Jack. MIDI IN and MIDI OUT are connected by MIDI Cable for MIDI loop check. Please connect Pa50 MIDI THRU and MIDI equipment's MIDI IN by MIDI Cable.

<Appearance Check>

Appearance Inspection → according to specified appearance limitation

To check if there are problems on Appearance Surface.

- a: Confirm if there is no scar on Appearance Surface including SWs/Knobs/Sliders.
- b: Confirm if there is no silk printing failure such as bleeding, cutting and so on
- c: Confirm if Switch, LED, VR and so on should be installed correctly. No gradient and unnecessary gaps and floating.
- d: By Visual Check, confirm if there is no height variety of keys.

<TEST MODE>

HOW TO ENTER TEST MODE PROGRAM

Please confirm if the connection is correct. After confirmation, install Floppy Disk and then Power ON.
After Power On, Display changes from (1) to (5) in order.

(1)



(2)



(3)

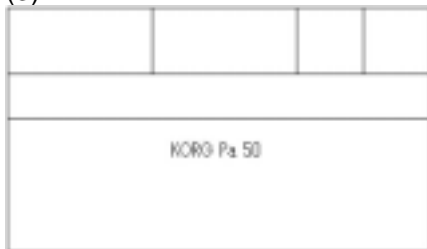

(4)



(5)



As soon as (5) is displayed, please press both **[STYLE PLAY]** SW and **[DISK]** SW ([STYLE PLAY] LED ON) and keep on press them until (6) is displayed and [STYLE PLAY] LED is OFF.
After confirm (6) display and [STYLE PLAY] LED off, please release the Switches.

(6)



(7)

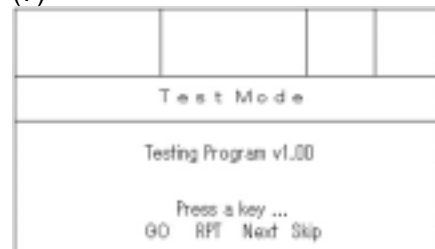

Finally (7) is displayed, Test Mode is loaded correctly. Please press [F1] to start

If Display proceed following (8) -> (9) after (6), you failed to enter Test Mode Program. In this case, please make power off and restart.

(8)



(9)



HOW TO OPERATE

SW	LCD	FUNCTION
[F1]	GO	Start Test Mode
[F2]	Rpt	Repeat Inspection
[F3]	Next	Go to Next Inspection
[F4]	Skip	Skip Inspection

In the interval of each inspection, **press key; -> ***** is displayed on LCD (** name of Inspection)

Press [F2] : you can do the last inspection you just completed again.

Press [F3] : You can go to next inspection displayed on LCD (**)

<CAUTION>

If you press [F3] while press key; -> ** is displayed on LCD, Test Mode go to next inspection irrespective of success or failure of inspection you just finished. So, please confirm if the last inspection is successful and then press [F3] and go to next inspection.

INTERNAL INSPECTION

Followings are checked during Internal Inspection Mode. In the case of NG, "FAULT!!!" is displayed on LCD.

NAND Check

TGL Check

TGL Dram Check

TGL Rom Check

Floppy Disk Check

MIDI Loop Check

Phone Insert Check

If DRAM or PCM ROM for TGL is NG (Open/Short Circuit or etc), TGL check result becomes NG and following is displayed on LCD. In this case, please finish Inspection.

press key; -> TGLPCMROM

If "FAULT!!!" is displayed during Floppy Disk Check, MIDI Loop Check, Phone Insert Check, please check connection and press [F2] to do re-test. If "FAULT!!!" is disappear, please continue. If "FAULT!!!" is displayed again, please finish test since result is NG.

When "FALUT!!!" is not displayed on LCD after Phone Insert Check completion, Internal Inspection is successful. Please press **[F3]** to go to Panel Inspection

(Caution)

"Phone Insert Check" is not displayed on LCD.

*After "MIDI Loop Check" completion, "RESOURCE" is displayed on LCD. This test is loading Pre-load Data from Hard Disk. Pa50 does not have Hard Disk and this test is not necessary.

Please press **[F4]**, then **[F3]** to go to Panel Inspection.

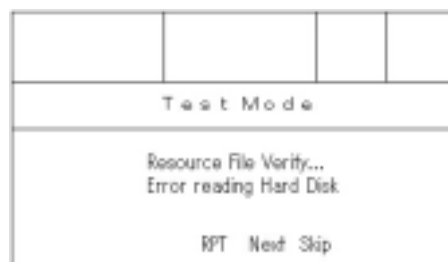

PANEL INSPECTION**1. ALL LEDS ON INSPECTION**

Please confirm if LCD Display is below, all LEDs are on and no variation of brightness.
Also please confirm if [START/STOP] LED is orange.

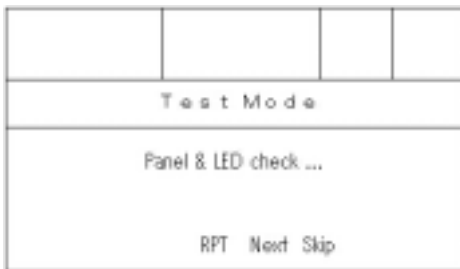

After confirmation, please press [F3] to go to next inspection

2. SW/LED INSPECTION

At first, [STYLE PLAY] LED is on. Please confirm LED ON according to the following list and press SW in order.

Display example:

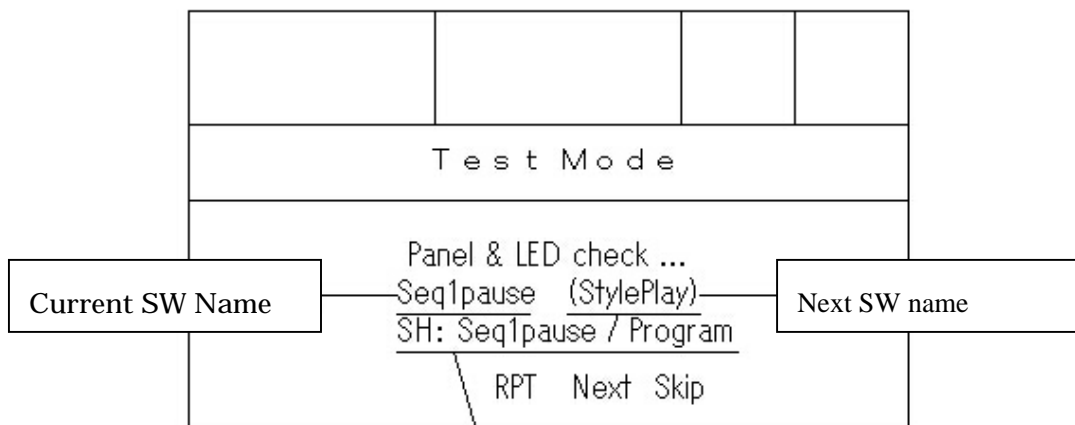

When you press two SWs simultaneously, these SWs name is displayed here. This display remain.

In the list, "LED OFF" means that all LEDs are off. Please confirm if all LEDs are off.

Following cases are NG:

*Even if correspondent SW is pressed, test does not progress

*LED is not on when the LED should be on.

*LED is on when LED should NOT be on.

In the case of NG, please complete the test.

Correspondent List is followed.

After "SW/LED Inspection" Completion, please press **[F3]** to go to "LCD Inspection".

<u>DISPLAY</u>	<u>Correspondent SW</u>	<u>Correspondent LED ON/LED OFF</u>
Ending1	ENDING [1]	ENDING [1]
Ending2	ENDING [2]	ENDING [2]
Intro1	INTRO [1]	INTRO [1]
Intro2	INTRO [2]	INTRO [2]
StartStop	[START/STOP]	[START/STOP] (RED)
Synchro	SYNCHRO [START]	SYNCHRO [START]
TapTempo	TAP TEMPO	SYNCHRO [STOP]
Write	[WRITE]	[WRITE]
Ensemble	[ENSEMBLE]	[ENSEMBLE]
Pad1	PAD[1]	LED OFF
Pad2	PAD[2]	LED OFF
Pad3	PAD[3]	LED OFF
Pad4	PAD[4]	LED OFF
PadStop	PAD[STOP]	LED OFF
Transp b	TRANSPOSE[b]	LED OFF
Transp #	TRANSPOSE[#]	LED OFF
Octave -	OCTAVE [-]	LED OFF
Octave +	OCTAVE [+]	LED OFF
Record	[RECORD]	[RECORD]
Menu	[MENU]	LED OFF
DrumPerc	[DRUM-PERC]	LED OFF
Drum	[DRUM]	LED OFF
Bass BASS/PERC	[BASS]	LED OFF
Perc BASS/PERC	[PERC]	LED OFF
Acc ACC/BASS	[ACC]	LED OFF
Bass ACC/BASS	[BASS]	LED OFF
--	-/ACC1 [-]	LED OFF
Acc1	-/ACC1 [ACC1]	LED OFF

<u>DISPLAY</u>	<u>Correspondent SW</u>	<u>Correspondent LED ON/LED OFF</u>
Seq1 <<	SEQUENCER 1[<<]	LED OFF
Seq1 >>	SEQUENCER 1[>>]	LED OFF
Seq1Pause	SEQUENCER 1[PAUSE]	LED OFF
Seq1PlayS	SEQUENCER 1[PLAY/STOP]	SEQUENCER 1[PLAY/STOP]
Seq2 <<	SEQUENCER 2[<<]	[START/STOP] Green
Seq2 >>	SEQUENCER 2[>>]	LED OFF
Seq2Pause	SEQUENCER 2[PAUSE]	LED OFF
Seq2PlayS	SEQUENCER 2[PLAY/STOP]	SEQUENCER 2[PLAY/STOP]
Prog.bank	PROGRAM Leftmost SW	Program bank Upper
Piano	[PIANO]	Program bank Lower
E.Piano	[E.PIANO]	LED OFF
Mallet	[MALLET & BELL]	LED OFF
Accordion	[ACCORDION]	LED OFF
Organ 1	[ORGAN 1]	LED OFF
Organ 2	[ORGAN 2]	LED OFF
Guitar	[GUITAR]	LED OFF
Strings	[STRINGS & VOCALS]	LED OFF
Trumpet	[TRUMPET & TROMBONE]	LED OFF
Brass	[BRASS]	LED OFF
Fade	[FADE IN/OUT]	[FADE IN/OUT]
Variat1	VARIATION [1]	VARIATION [1]
Variat2	VARIATION [2]	VARIATION [2]
Variat3	VARIATION [3]	VARIATION [3]
Variat4	VARIATION [4]	VARIATION [4]
Fill1	FILL [1]	FILL [1]
Fill2	FILL [2]	FILL [2]
Break	[COUNT IN BREAK]	[COUNT IN BREAK]

Correspondence Table

Displayed SW Name on LCD / Correspondent SW / Correspondent LED name switched on or LED OFF

<u>DISPLAY</u>	<u>Correspondent SW</u>	<u>Correspondent LED ON/LED OFF</u>
StylePlay	[STYLE PLAY]	[STYLE PLAY]
SongPlay	[SONG PLAY]	[SONG PLAY]
BSeq	[B.SEQ]	[B.SEQ]
Song	[SONG]	[SONG]
Program	[PROGRAM]	[PROGRAM]
Global	[GLOBAL]	LED OFF
Disk	[DISK]	LED OFF
Memory	[MEMORY]	[MEMORY]
BassInv	[BASS INV.]	[BASS INV.]
ManBass	[MAN.BASS]	[MAN.BASS]
SplitPnt	[SPLIT POINT]	LED OFF
G.Quantiz	[G.QUANTIZE]	LED OFF
Tempo	[TEMPO]	[TEMPO]
SingleTch	[SINGLE TOUCH]	[SINGLE TOUCH]
Style bank	STYLE Leftmore SW	Style bank Upper
Beat1	[8/16 BEAT1]	Style bank Lower
Beat2	[8/16 BEAT2]	LED OFF
Ballad	[BALLAD]	LED OFF
Ballroom	[BALLROOM]	LED OFF
Dance	[DANCE]	LED OFF
Rock	[ROCK]	LED OFF
Soul&F	[SOUL & FUNK]	LED OFF
World1	[WORLD 1]	LED OFF
World2	[WORLD 2]	LED OFF
World3	[WORLD 3]	LED OFF

<u>DISPLAY</u>	<u>Correspondent SW</u>	<u>Correspondent LED ON/LED OFF</u>
Page -	PAGE[-]	LED OFF
Page +	PAGE[+]	LED OFF
Upper1	[UPPER1]	LED OFF
Acc2 [ACC2]	LED OFF
Upper2	[UPPER2]	LED OFF
Acc3	[ACC3]	LED OFF
Upper3	[UPPER3]	LED OFF
Acc4	[ACC4]	LED OFF
Lower	[LOWER]	LED OFF
Acc5	[ACC5]	LED OFF
Trk.Sel	[TRK.SELECT]	[TRK.SELECT]
F1	[F1]	LED OFF
F2	[F2]	LED OFF
F3	[F3]	LED OFF
F4	[F4]	LED OFF
Shift	[SHIFT]	[SHIFT]
Down	[DOWN/-]	LED OFF
Up	[UP/+]	[VALUE]
Exit	[EXIT/NO]	LED OFF
Enter	[ENTER/YES]	LED OFF
Display	[DISPLAY HOLD]	[DISPLAY HOLD]
Lower CHORD	[LOWER]	CHORD [LOWER]
Upper CHORD	[UPPER]	CHORD [UPPER]
Split	[SPLIT]	[SPLIT]
FullUpper	[FULL UPPER]	[FULL UPPER]
StyleChg	[STYLE CHANGE]	[STYLE CHANGE]
Perform	[PERFORM.]	[PERFORM.]
Program	[PROGRAM.]	[PROGRAM.]

LCD INSPECTION**1. ALL DISPLAY**

All icons are displayed as below.

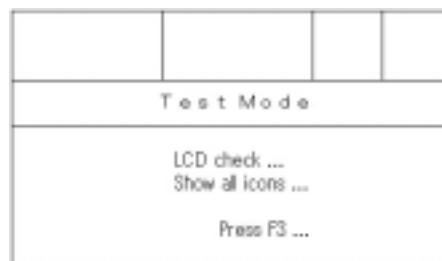
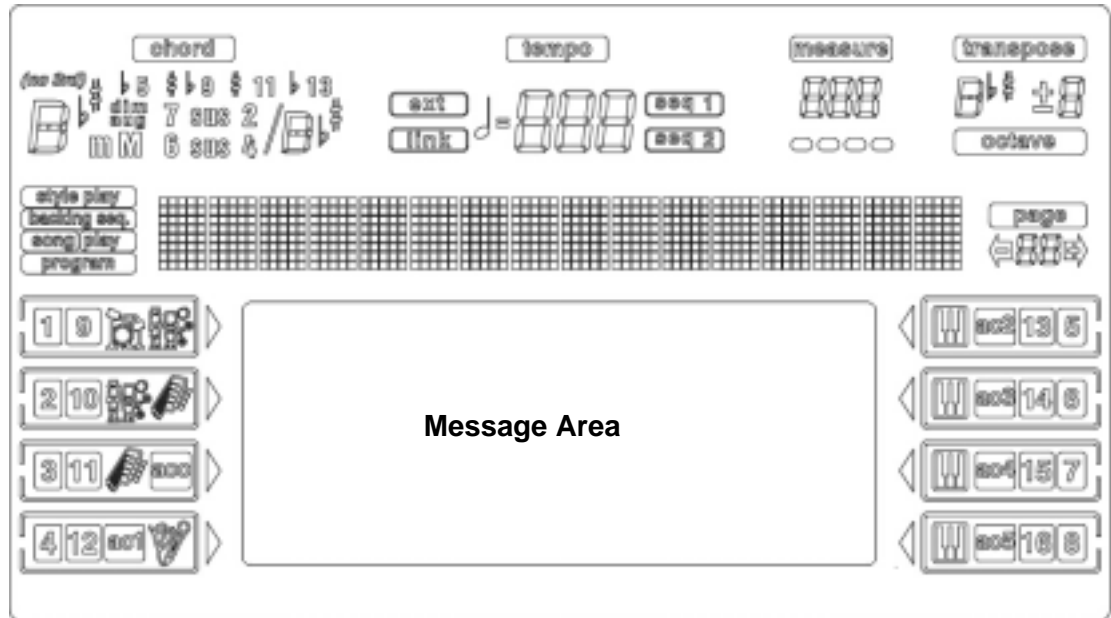

Please confirm if all icons are displayed correctly and the above content is displayed in Message Area.
After confirmation, please press **[F3]**.

2. [>]DISPLAY

Please confirm if all icons are disappeared and following content is displayed in Message Area.



After confirmation, please press **[F3]**.

3. [<]DISPLAY

Please confirm if following content is displayed in Message Area

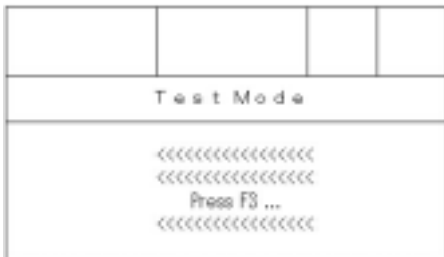

After confirmation, please press **[F3]**.

4. [#]DISPLAY

Please confirm if following content is displayed in Message Area

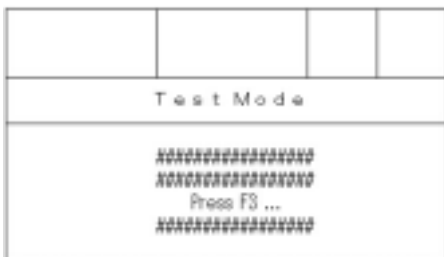

After confirmation, please press **[F3]**.

5. [8] Display

Please confirm if following content is displayed in Message Area



After confirmation, please press **[F3]**.

6. [X] Display

Please confirm if following content is displayed in Message Area

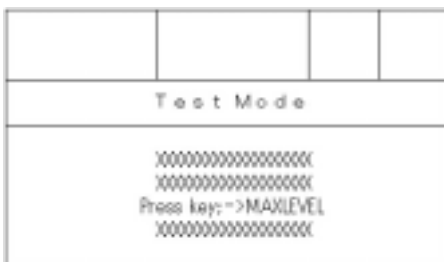

After confirmation, please press **[F3]** to go to Max Level Inspection.

Max Level Inspection

Signal is outputted from Each Inspected Terminal.

MAKE Master Volume level MAX and then

CHECK if output level is within Range below.

CHECK if distortion of wave of Oscilloscope is less than 0.5%. Please refer to wave figure below.

Setting of OSCILLOSCOPE: DC

After confirmation, press [F3]

1/4 : INSERT DAMMY PLUG INTO [OUTPUT RIGHT]

OUTPUT : [OUTPUT L/MONO] : 1[KHz], 10.0[Vp-p] - 11.5[Vp-p]

2/4 : INSERT DAMMY PLUG INTO [OUTPUT L/MONO]

OUTPUT : [OUTPUT RIGHT] : 1[KHz], 10.0[Vp-p] - 11.5[Vp-p]

3/4 : SHIELD CABLE with 33ohm impedance.

OUTPUT : [PHONES L] : 440[Hz], 1.80[Vp-p] - 3.20[Vp-p]

4/4 : SHIELD CABLE with 33ohm impedance

OUTPUT : [PHONES R] : 880[Hz], 1.80[Vp-p] - 3.20[Vp-p]

Caution

During this inspection, Pa50 may hang-up very rarely. In this case, shut off power at once and load the TEST MODE again and make same inspection.

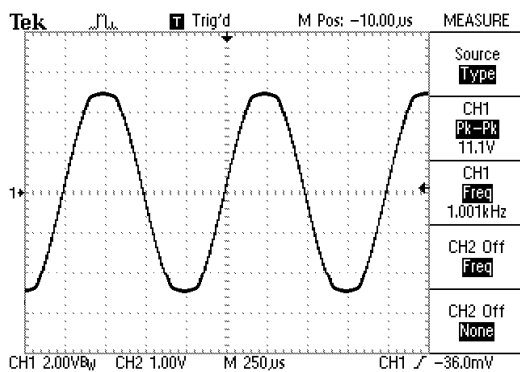

Example without distortion

Oscilloscope setting : DC

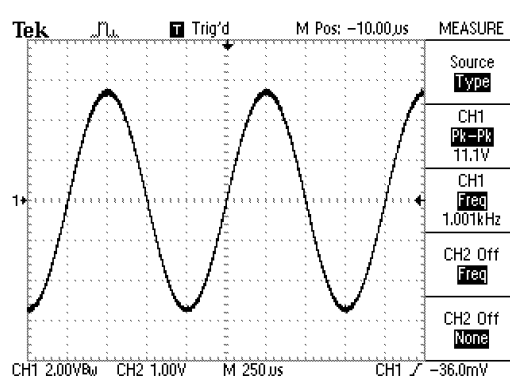

Example with distortion

After 4/4 measurement is completed and display proceed to (A), please press **[F4]** to go to (B) display.
After confirmation of (B) display, please press **[F3]** to go to SLIDE INSPECTION.

(A)

Test Mode			
Max Level Check. 1/2			
press key: -> LINE IN RPT Next Skip			

(B)

Test Mode			
Max Level Check. 1/2			
press key: -> SLIDER RPT Next Skip			

SLIDER INSPECTION

1. Confirm if "**Press Key; -> SLIDER**" is displayed on LCD
2. Operate Sliders and pedals in order of followings and confirm if its maximum value and minimum value are taken. (Displayed on LCD).

Joystick Horizontal Direction →→ Joystick Vertical Direction →→ ACC/SEQ Slider →→
Volume →→ Assign Slider →→ Balance →→ Assignable Pedal →→ Damper

NOTE 1: Value of Damper

Please confirm to get the following value.

STEP ON: < 7F

STEP OFF >7F

NOTE 2: When you return joystick to center, please confirm if its position value becomes 80 in horizontal direction and 00 in vertical direction.

After completion, press **[F3]**

DIAL INSPECTION

Inspection of Dial

1. PRESS [F3] after "**Press key; -> DIAL**" is displayed on LCD.
2. Set Dial so that the hollow of the dial comes right above.
3. Press **[UP/+]**
4. Go around the dial clockwise and turn to the position of the right above same again
5. Confirm if **the Value +24** is displayed on LCD.
6. After confirmation Press **[UP/+]** again
7. Go around the dial anti-clockwise and turn to the position of the right above same.
8. Confirm if **the value -24** is displayed on LCD.
9. After confirmation, Press **[F3]**

SPEAKER INSPECTION

Inspection for Speakers

1. Press [F3] after "**Press key; -> SPEAKER**" is displayed on LCD
2. Adjust Master Volume and confirm if Low Range Sound comes from Left Speaker and No sound comes from Right Speaker.
3. After confirmation, Press **[F3]**
4. Adjust Master Volume and confirm if Low Range Sound comes from Right Speaker and No sound comes from Left Speaker.
5. "**Press Key; -> KEYBOARD**" is displayed on LCD. After confirmation on this display, Press **[F3]**

KEYBOARD INSPECTION

Keyboard check...

Next note: C7

After confirmation on the above display, play key from C7 the rightmost one by one in order
When you hit the key, key name you hit and its velocity for the key are displayed on LCD.

KEY ON : C7 , v.55

OK Range of Velocity: from 40 to 95

In the case of hitting other keys in mistake during this test, sound stops. In this case, please hit correctly.

When the test reaches C2 (the leftmost key), "**press key; -> end**" is displayed on LCD automatically.
Press **[F3]** and you can find following display.



After confirmation on the display above, Press [F3]

"RESTART !!!" is displayed on LCD

Please shut down.

TEST MODE COMPLETION

NEXT STEP is PERFORMANCE CHECK

<PERFORMANCE CHECK>

MIDI THRU, MIDI Clock and Performance Inspection.

After Power on, confirm if Pa50 performs correctly. Following is the method of MIDI THRU and MIDI Clock Inspection. Please send "Program Change" from Pa50 to MIDI Equipment and Inspect.

1. MODE [PROGRAM] SW on.
2. PROGRAM [PIANO] SW on.
3.]LOWER/ACC5] SW on

After completion, please check if Pa50 works properly.

After confirmation, please press [STYLE] first, then [START/STOP] and confirm Demo Song is played correctly.

After confirmation of PA50 operation, this inspection completes. Please make power off and take cables and Floppy disk out of Pa50.

<FQC AUDIO INSPECTION/MEASUREMENT>

Please make Audio inspection/measurement below on all Pa50.

Frequency Response Check

Line in Check

Distortion Check

Noise Check

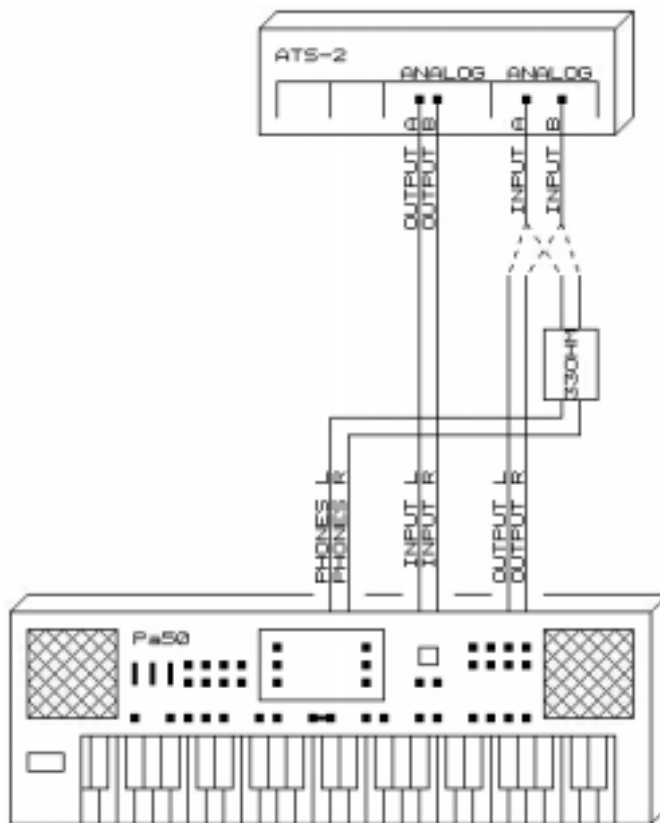
CONNECTION

When you start FAC, please connect Pa50 output and Audio Analyzer's Input.

Equipment

Audio Precision ATS-2 : Audio Analyzer

Please refer to each description for Audio Analyzer Setting.

Enter Test Mode

Please enter TEST MODE. After "Internal Inspection" completes, please press **[F4]** until **press key; -> LINE IN** is displayed on LCD. After confirmation of Display, please press **[F3]** and confirm the following LCD display.

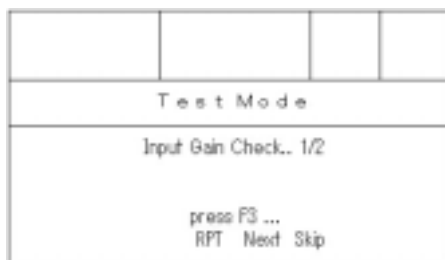

Frequency Response Check

1. IN-OUT L 100[Hz]
Input Signal : INPUT L/MONO, 100[Hz], 1[Vrms]
Range : OUTPUT L/MONO, 100[Hz], -3.0 to -1.0[dBV]
2. IN-OUT L 1[KHz]
Input Signal : INPUT L/MONO, 1[KHz], 1[Vrms]
Range : OUTPUT L/MONO, 1[KHz], -3.0 to -1.0[dBV]
3. IN-OUT L 10[KHz]
Input Signal : INPUT L/MONO, 10[KHz], 1[Vrms]
Range : OUTPUT L/MONO, 10[KHz], -3.0 to -1.0[dBV]
4. IN-OUT R 100[Hz]
Input Signal : INPUT R, 100[Hz], 1[Vrms]
Range : OUTPUT R, 100[Hz], -3.0 to -1.0[dBV]
5. IN-OUT R 1[KHz]
Input Signal : INPUT R, 1[KHz], 1[Vrms]
Range : OUTPUT R, 1[KHz], -3.0 to -1.0[dBV]
7. IN-OUT R 10[KHz]
Input Signal : INPUT R, 10[KHz], 1[Vrms]
Range : OUTPUT R, 10[KHz], -3.0 to -1.0[dBV]

LINE IN CHECK

1. INPUT L, 1[KHz]

Input Signal : INPUT L/MONO, 1[KHz], 0.775[Vpp]

Range : OUTPUT L/MONO, 1[KHz], -0.488 to -0.775[Vpp]

2. INPUT R, 1[KHz]

Input Signal : INPUT R, 1[KHz], 0.775[Vpp]

Range : OUTPUT R, 1[KHz], -0.488 to -0.775[Vpp]

DISTORTION CHECK

Setting for Audio Analyzer:

LPF : 20[KHz]

HPF : 10[Hz]

The Audio compensation Filter : None

1. OUTPUT L/MONO

Input Signal : INPUT L/MONO, 1[KHz], 1[Vrms]

Range : OUTPUT L/MONO, 1[KHz], Less than 0.5[%]

2. OUTPUT R

Input Signal : INPUT R, 1[KHz], 1[Vrms]

Range : OUTPUT R, 1[KHz], Less than 0.5[%]

NOISE CHECK

Setting for Audio Analyzer

LPF : 20[KHz]

HPF : 10[Hz]

The Audio compensation Filter : "A"weighting

When you measure phones, please change Input Cable from Output to Phones.

Measurement Standard Range:

OUTPUT L/MONO	:	Less than -78.0[dB]
OUTPUT R	:	Less than -78.0[dB]
PHONES L	:	Less than -80.0[dB]
PHONES R	:	Less than -80.0[dB]

Instructions for QA Full Inspection

This inspection is carried out supposing a user's usual use situation, and measurement of the electric spec. of details etc. is omitted.

An inspection order does not need to follow below. All inspection being finally carried out will be important. Please refer to the attached drawing on Connection.

On connecting plug, please check Insertion and Extraction Force with Jack.

<PREPARATION>

Floppy Disk Specified SMF Data included
Floppy Disk Blank Disk Formatted by Pa50
Damper Pedal DS-1H
Assignable SW EXP-1
Headphone
MIDI Cable
CD Player
Monitor Amplifier
33ohm load Shield Cable (33ohm impedance Headphone can be substituted.)

*33ohm load Shield Cable (or Headphone) to Phone Jack.

*Connect MIDI IN and MIDI OUT by MIDI Cable (Loop connection)

<TEST>

1. Appearance Inspection → according to specified appearance limitation
 To check if there are problems on Appearance Surface.
 - a: Confirm if there is no scar on Appearance Surface including SWs/Knobs/Sliders.
 - b: Confirm if there is no silk printing failure such as bleeding, cutting and so on
 - c: Confirm if Switch, LED, VR and so on should be installed correctly. No gradient and unnecessary gaps and floating.
 - d: By Visual Check, confirm if there is no height variety of keys.

2. MUSIC STAND CHECK
 Please refer to our email dated on July 16.
 Please install packed Music Stand on the keyboard and check if it can be installed smoothly.

----- **LOAD TEST MODE** -----

Please confirm if the connection is correct. After confirmation, install Floppy Disk and then Power ON.

----- **LOAD TEST MODE** -----

Please confirm if the connection is correct. After confirmation, install Floppy Disk and then Power ON.
After Power On, Display changes from (1) to (5) in order.

(1)



(2)



(3)

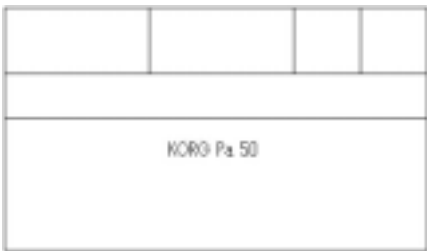

(4)

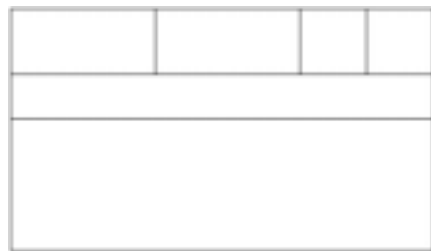

(5)



As soon as (5) is displayed, please press both [STYLE PLAY] SW and [DISK] SW ([STYLE PLAY] LED ON) and keep on press them until (6) is displayed and [STYLE PLAY] LED is OFF.
After confirm (6) display and [STYLE PLAY] LED off, please release the Switches.

(6)



(7)

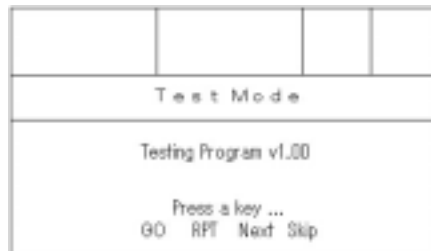

Finally (7) is displayed, Test Mode is loaded correctly.

Please press [F1] to start Internal Test.

If (8) -> (9) are displayed after (6), Test Mode is not loaded correctly. Please turn off and restart from first step.

(8)



(9)



<How to operation>

SW	LCD	FUNCTION
[F1]	GO	Start Test Mode
[F2]	Rpt	Repeat Inspection
[F3]	Next	Go to Next Inspection
[F4]	Skip	Skip Inspection

In the interval of each inspection, **press key; -> ***** is displayed on LCD (***) name of Inspection)

Press [F2] : you can do the last inspection you just completed again.

Press [F3] : You can go to next inspection displayed on LCD (***)

<CAUTION>

If you press [F3] while press key; -> *** is displayed on LCD, Test Mode go to next inspection irrespective of success or failure of inspection you just finished. So, please confirm if the last inspection is successful and then press [F3] and go to next inspection.

3. INTERNAL INSPECTION

Internal Inspection inspects following contents

When NG is found, **FAULT!!!** is displayed on LCD.

NAND CHECK

TGL Check

TGL Dram Check

TGL ROM Check

Floppy Disk Check

MIDI Loop Check

Phone Insert Check

In the case that NG such as Open/Short is found in DRAM or PDM ROM for TGL, TGL Check becomes fault and press **key**; -> **TGLPCMROM** is displayed. If this sentence is displayed, complete test mode.

If **FAULT!!!** is not displayed after finish of Phone Insert Check, Internal Inspection is successful. Please press [F3] to go to next inspection.

If **FAULT!!!** is displayed During Floppy Disk Check , MIDI Loop Check, Phone Insert Check, please check connection and press [F2] to repeat Internal check. If **FAULT!!!** is displayed again, the Pa50 internal test result is failure. Please complete the test and inspect next Pa50. If **FAULT!!!** is disappear, please proceed test.

RESOURCE is displayed after Phone Insert Check. this procedure does not need for Pa50 FQC. So please ignore this display and press [F4] -> [F3] to go to next Inspection (Panel Inspection)



4 PANEL INSPECTION

4-1 All LED ON INSPECTION

Please confirm if LCD Display is below, all LEDs are on and no variation of brightness. Also please confirm if [START/STOP] LED is orange.

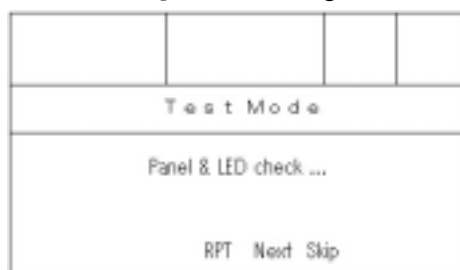

After confirmation, please press [F3] to go to next inspection

4-2 SW/LED INSPECTION

At first, [STYLE PLAY] LED is on. Please confirm LED ON according to the following list and press SW in order.

Display example:

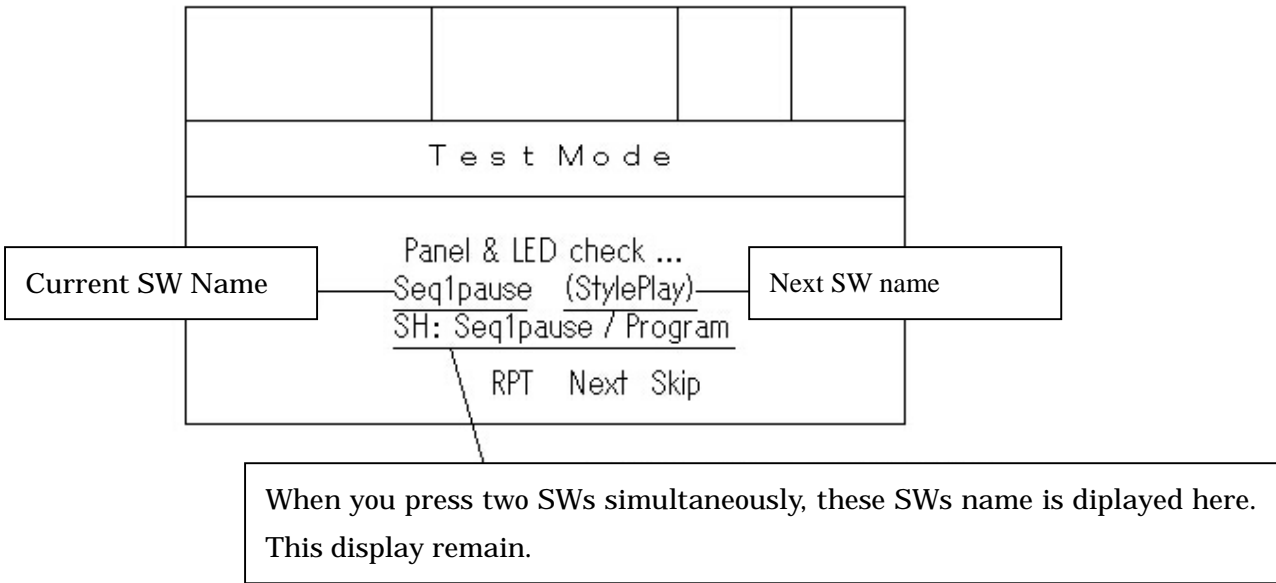

In the list, "LED OFF" means that all LEDs are off. Please confirm if all LEDs are off.

Following cases are NG:

- *Even if correspondent SW is pressed, test does not progress
- *LED is not on when the LED should be on.
- *LED is on when LED should NOT be on.

In the case of NG, please complete the test.

For QA Full Inspection, following inspections by Test Mode are not necessary. Please skip following inspections by press [F4]. Finally following is displayed.



After confirmation above, Press [F3]. Following is displayed. Please confirm it and turn off Pa50

TEST MODE COMPLETION

Turn Pa50 on.

5-1 Demo Song Start

Press [STYLE PLAY]SW and [SONG PLAY]SW simultaneously.

Internal Demo Song start automatically.

5-2 Check followings

*Move Master VR from 0 to 10 to check speaker volume varies smoothly.

*Check if no VR Moving Noise (Cycle Noise)

* Confirm if the body does not vibrate

NOTE: Please shake (or hit) body lightly in order to check if there are any internal soldering problems.

5-3 Connect Headphone to Pa50 and have it to check if Headphone output works correctly.

5-4 Keep on connecting Headphone to Pa50 and check if LINE OUT output works correctly by Monitor Amplifiers.

Disconnect Headphone



Stop Demo Performance: Press [SART/STOP]

Press [MODE/PRGRAM] in order to escape from DEMO MODE

5-5 On hitting key strongly, check if sound comes with normal velocity value.
(All keys should be inspected.)

5-6 On hitting key weakly, check if sound comes with normal velocity value.
(All keys should be inspected.)

5-7 Check if Damper function works correctly by equipment connected to Damper Jack.

Press [MODE/STYLE PLAY] key

5-8 Assignable SW/Pedal Operation Inspection

Check if Style performs automatically on PEDAL ON and it stops on PEDAL OFF.

NOTE: When you are in MODE/STYLE, performance starts as soon as Pedal is connected.
So, Pedal should be connected before power on

5-9 Connect Sound Source (such as CD Player) to LINE IN and check if Pa50's speakers works correctly.

5-10 Insert FDD in which SMF file data is written into FDD and check if SMF file is performed correctly.

- [MODE/SONG] key ON
- Insert FDD
- Press [BASS/PERC] key among Volume Value Keys
- Press [F-2] key
- Press [ENTER/YES] ("Wait" is displayed)
- Confirm if "KA02-010" is displayed on LCD (KA02-010 is SMF name)
- Press [SEQUENCER1 PLAY/STOP] key to start.
- After confirmation if performance is correct (about 10 measures), Press Press [SEQUENCER1 PLAY/STOP] key to stop

STOP Performance



Extract FD from FDD without Failure



Power Off

CAUTION!

Do not pass Pa50 to next process with FD inserted. Management of the number of FD is always needed.

[Pa50 QA Full Inspection Connection](#)

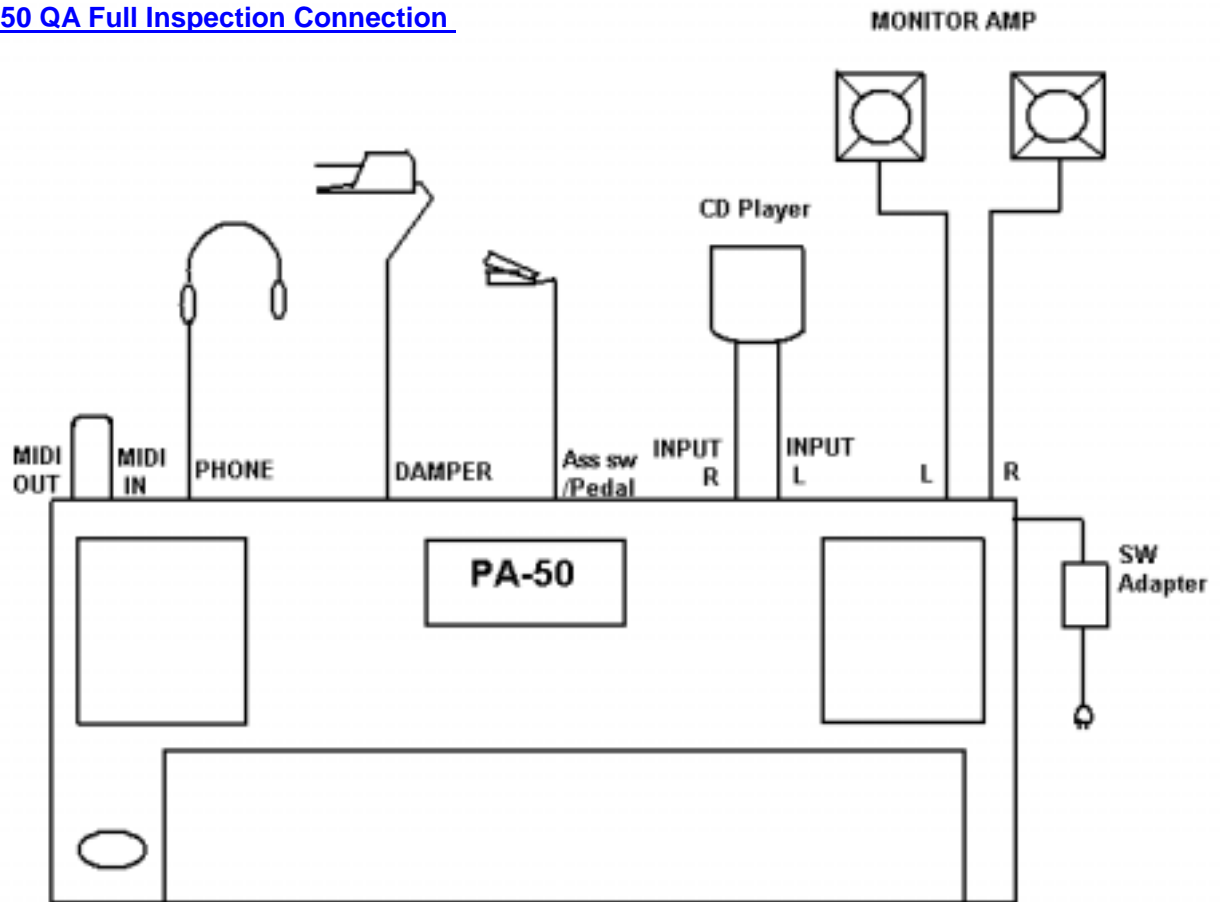

<u>DISPLAY</u>	<u>Correspondent SW</u>	<u>Correspondent LED ON/LED OFF</u>
Ending1	ENDING [1]	ENDING [1]
Ending2	ENDING [2]	ENDING [2]
Intro1	INTRO [1]	INTRO [1]
Intro2	INTRO [2]	INTRO [2]
StartStop	[START/STOP]	[START/STOP] (RED)
Synchro	SYNCHRO [START]	SYNCHRO [START]
TapTempo	TAP TEMPO	SYNCHRO [STOP]
Write	[WRITE]	[WRITE]
Ensemble	[ENSEMBLE]	[ENSEMBLE]
Pad1	PAD[1]	LED OFF
Pad2	PAD[2]	LED OFF
Pad3	PAD[3]	LED OFF
Pad4	PAD[4]	LED OFF
PadStop	PAD[STOP]	LED OFF
Transp b	TRANSPOSE[b]	LED OFF
Transp #	TRANSPOSE[#]	LED OFF
Octave -	OCTAVE [-]	LED OFF
Octave +	OCTAVE [+]	LED OFF
Record	[RECORD]	[RECORD]
Menu	[MENU]	LED OFF
DrumPerc	[DRUM-PERC]	LED OFF
Drum	[DRUM]	LED OFF
Bass BASS/PERC	[BASS]	LED OFF
Perc BASS/PERC	[PERC]	LED OFF
Acc ACC/BASS	[ACC]	LED OFF
Bass ACC/BASS	[BASS]	LED OFF
--	-/ACC1 [-]	LED OFF
Acc1	-/ACC1 [ACC1]	LED OFF

<u>DISPLAY</u>	<u>Correspondent SW</u>	<u>Correspondent LED ON/LED OFF</u>
Seq1 <<	SEQUENCER 1[<<]	LED OFF
Seq1 >>	SEQUENCER 1[>>]	LED OFF
Seq1Pause	SEQUENCER 1[PAUSE]	LED OFF
Seq1PlayS	SEQUENCER 1[PLAY/STOP]	SEQUENCER 1[PLAY/STOP]
Seq2 <<	SEQUENCER 2[<<]	[START/STOP] Green
Seq2 >>	SEQUENCER 2[>>]	LED OFF
Seq2Pause	SEQUENCER 2[PAUSE]	LED OFF
Seq2PlayS	SEQUENCER 2[PLAY/STOP]	SEQUENCER 2[PLAY/STOP]
Prog.bank	PROGRAM Leftmost SW	Program bank Upper
Piano	[PIANO]	Program bank Lower
E.Piano	[E.PIANO]	LED OFF
Mallet	[MALLET & BELL]	LED OFF
Accordion	[ACCORDION]	LED OFF
Organ 1	[ORGAN 1]	LED OFF
Organ 2	[ORGAN 2]	LED OFF
Guitar	[GUITAR]	LED OFF
Strings	[STRINGS & VOCALS]	LED OFF
Trumpet	[TRUMPET & TROMBONE]	LED OFF
Brass	[BRASS]	LED OFF
Fade	[FADE IN/OUT]	[FADE IN/OUT]
Variat1	VARIATION [1]	VARIATION [1]
Variat2	VARIATION [2]	VARIATION [2]
Variat3	VARIATION [3]	VARIATION [3]
Variat4	VARIATION [4]	VARIATION [4]
Fill1	FILL [1]	FILL [1]
Fill2	FILL [2]	FILL [2]
Break	[COUNT IN BREAK]	[COUNT IN BREAK]

Correspondence Table

Displayed SW Name on LCD / Correspondent SW / Correspondent LED name switched on or LED OFF

<u>DISPLAY</u>	<u>Correspondent SW</u>	<u>Correspondent LED ON/LED OFF</u>
StylePlay	[STYLE PLAY]	[STYLE PLAY]
SongPlay	[SONG PLAY]	[SONG PLAY]
BSeq	[B.SEQ]	[B.SEQ]
Song	[SONG]	[SONG]
Program	[PROGRAM]	[PROGRAM]
Global	[GLOBAL]	LED OFF
Disk	[DISK]	LED OFF
Memory	[MEMORY]	[MEMORY]
BassInv	[BASS INV.]	[BASS INV.]
ManBass	[MAN.BASS]	[MAN.BASS]
SplitPnt	[SPLIT POINT]	LED OFF
G.Quantiz	[G.QUANTIZE]	LED OFF
Tempo	[TEMPO]	[TEMPO]
SingleTch	[SINGLE TOUCH]	[SINGLE TOUCH]
Style bank	STYLE Leftmore SW	Style bank Upper
Beat1	[8/16 BEAT1]	Style bank Lower
Beat2	[8/16 BEAT2]	LED OFF
Ballad	[BALLAD]	LED OFF
Ballroom	[BALLROOM]	LED OFF
Dance	[DANCE]	LED OFF
Rock	[ROCK]	LED OFF
Soul&F	[SOUL & FUNK]	LED OFF
World1	[WORLD 1]	LED OFF
World2	[WORLD 2]	LED OFF
World3	[WORLD 3]	LED OFF

<u>DISPLAY</u>	<u>Correspondent SW</u>	<u>Correspondent LED ON/LED OFF</u>
Page -	PAGE[-]	LED OFF
Page +	PAGE[+]	LED OFF
Upper1	[UPPER1]	LED OFF
Acc2 [ACC2]	LED OFF
Upper2	[UPPER2]	LED OFF
Acc3	[ACC3]	LED OFF
Upper3	[UPPER3]	LED OFF
Acc4	[ACC4]	LED OFF
Lower	[LOWER]	LED OFF
Acc5	[ACC5]	LED OFF
Trk.Sel	[TRK.SELECT]	[TRK.SELECT]
F1	[F1]	LED OFF
F2	[F2]	LED OFF
F3	[F3]	LED OFF
F4	[F4]	LED OFF
Shift	[SHIFT]	[SHIFT]
Down	[DOWN/-]	LED OFF
Up	[UP/+]	[VALUE]
Exit	[EXIT/NO]	LED OFF
Enter	[ENTER/YES]	LED OFF
Display	[DISPLAY HOLD]	[DISPLAY HOLD]
Lower CHORD	[LOWER]	CHORD [LOWER]
Upper CHORD	[UPPER]	CHORD [UPPER]
Split	[SPLIT]	[SPLIT]
FullUpper	[FULL UPPER]	[FULL UPPER]
StyleChg	[STYLE CHANGE]	[STYLE CHANGE]
Perform	[PERFORM.]	[PERFORM.]
Program	[PROGRAM.]	[PROGRAM.]

Sampling Inspection for Packing

July 25, 2003

In order to maintain quality of Packing, sampling inspection to packed up Pa50 should be carried out every day whenever Pa50 is produced.

Inspection Contents are as follows.

1. The number of Sampling Inspection
3 pcs. to each Voltage Allocation produced every day.
ex:
one day: produce 30 x 117EX, 20 x 230GE, 20 x 230UK
Sampling Q'ty: 3 x 117EX, 3 x 230GE, 3 x 230UK
2. Check if Pa50 is put into package as specified.
Check if the product is packed in correct direction. *1)
3. Check if Accessories specified are put into package as specified
(It depends on each Voltage Allocation)
Parts for Voltage Allocation: AC Cordset/Owner's Manual/Warranty and so on.
4. Check if Printing on packages is correct (Color, position and so on)
5. Check if Delivery Label including Serial Number, Product Name, Voltage allocation is correct. The most important point is that Serial Number printed on label should be same as one of Pa50 packed.
6. Please check if Tape and staples specified are used for packing and their position is correct.

END Page-1 of 1

*1) It was added on October 24, 2003.

PART CODE	PART NAME	NOTE	Q'TY
320004692	IC HD6433394A35F(NKS3.5) SMD	FUNC.CONTROL BOARD	1
320012223	IC MB87F1710PFV-G-BND QFP	MAIN BOARD	1
320012321	IC MBCG46183-205(MCM99) QFP	MAIN BOARD	1
*MP5000100	PA-50 61KEYS STANDARD KEYBOARD	M.PART	1
*MP5000101	61 KEYBOARD WHITE KEY(HI-C)	M.PART	1
*MP5000102	61 KEYBOARD WHITE KEYS (D/A/F)	M.PART	5
*MP5000103	61 KEYBOARD WHITE KEYS(C/E/G/B	M.PART	5
*MP5000104	61-VSK OCTAVE BLACK KEYS	M.PART	5
*MP5000105	61 KEYBOARD LEFT PCB ASSY	M.PART	1
*MP5000106	61 KEYBOARD RIGHT PCB ASSY	M.PART	1
*MP5000200	PA-50 LCD HOOD	M.PART	1
*MP5000201	PA-50 LCD BOARD ASSY CB4	M.PART	1
*MP5000202	PA-50 LCD LAMP BOARD ASSY LB1	M.PART	1
*MP5000203	PA-50 CONTROL BOARD ASSY MF1	M.PART	1
*MP5000300	PA-50 AMP BOARD ASSY AB4	M.PART	1
*MP5000400	PA-50 ENCODER BOARD ASSY DB2	M.PART	1
*MP5000500	PA-50 FUNCTION BOARD ASSY FB3	M.PART	1
*MP5000600	PA-50 INTERFACE BOARD ASSY IB3	M.PART	1
*MP5000700	PA-50 MAIN BOARD ASSY MB3	M.PART	1
*MP5000800	PA-50 FUNC. CONTROL BOARD RF2	M.PART	1
*MP5000900	PA-50 JOYSTICK ASSY	M.PART	1
*MP5000901	PA-50 JOYSTICK BOARD ASSY	M.PART	1
*MP5001001	TRANSFOMER GS-1336THF	LAMP BOARD	1
*MP5001002	TRANSFOMER TRF-100UH CCEE	AMP BOARD	2
*MP5001003	FDD 1.44" MF-355F-3252MG	M.PART	1
*MP5001004	SPEAKER 4 OHM 15W 4"(105MM)	M.PART	2
*MP5001005	SW ADAPTOR DSA-0421S-12342	M.PART	1
*MP5005001	PA-50 BACK LAMP WHITE	LAMP BOARD	1
*MP5005101	RED LED WEJ-2114D DIP	FUNCTION BOARD	32
*MP5005101	RED LED WEJ-2114D DIP	FUNC.CONTROL BOARD	9
*MP5005102	RED SMD LED 0603 WEF0603BR	LCD CONTROL BOARD	3
*MP5005103	PA50 DUAL-COLOUR LED WEJ-316AW	FUNCTION BOARD	1
*MP5005501	PA-50 LCD DISPLAY V52045	LCD BOARD	1
*MP5006001	IC S6A00065B DICE BONDING	LCD BOARD	5
*MP5006002	IC REGULATOR 7808 DIP TYPE	AMP BOARD	1
*MP5006003	IC 7908 DIP TYPE	AMP BOARD	1
*MP5006004	IC MC34063A DIP TYPE	AMP BOARD	1
*MP5006005	IC LA4708 DIP TYPE	AMP BOARD	1
*MP5006006	IC PC910K DIP TYPE	I/F BOARD	1
*MP5006007	IC 74AHCT04 DIP TYPE	I/F BOARD	1
*MP5006008	IC BA15218 DIP TYPE	I/F BOARD	2
*MP5006009	IC NJM4556AD SOP	I/F BOARD	1
*MP5006010	IC BA3823LS ZIP TYPE	AMP BOARD	1
*MP5006011	IC REGULATOR LM2576T-5 DIP	AMP BOARD	1
*MP5006012	IC 82C765 PLCC TYPE	MAIN BOARD	1
*MP5006016	IC MCF5307 MICRO 32BIT	MAIN BOARD	1
*MP5006017	IC TL084 SOP TYPE	LCD BOARD	1
*MP5006018	IC IMP811SEUS SOT-143 TYPE	MAIN BOARD	1
*MP5006019	IC 74HC02D SOP TYPE	MAIN BOARD	1
*MP5006020	IC 74HC138 SOP TYPE	FUNC.CONTROL BOARD	3
*MP5006021	IC BA033FP SOP TYPE	MAIN BOARD	1

PART CODE	PART NAME	NOTE	Q'TY
*MP5006022	IC BA178M05FP SOP TYPE	MAIN BOARD	1
*MP5006023	IC NJM4580 SOP TYPE	MAIN BOARD	2
*MP5006024	IC PCM1716E SOP TYPE	MAIN BOARD	1
*MP5006025	IC SN74AHCT244DW SOP TYPE	MAIN BOARD	6
*MP5006026	IC SN74AHC374DW SOP TYPE	MAIN BOARD	1
*MP5006027	IC SN74AHCT139D SOP TYPE	MAIN BOARD	1
*MP5006028	IC 74HC4053D SOP TYPE	FUNC.CONTROL BOARD	1
*MP5006029	IC SN74LVC32D SOP TYPE	MAIN BOARD	1
*MP5006030	IC SN74LVC4245DB SOP TYPE	MAIN BOARD	2
*MP5006031	IC TC74VHC21FN SOP TYPE	MAIN BOARD	1
*MP5006032	IC IS42S16400-7T SOP TYPE	MAIN BOARD	1
*MP5006033	IC MSM5118165F-60TK SOP TYPE	MAIN BOARD	1
*MP5006034	IC MX23C6410MC-10 BK0H KORG	MAIN BOARD	1
*MP5006035	IC MX23C6410MC-10 BK0L KORG	MAIN BOARD	1
*MP5006036	IC MX23C6410MC-10 BK1H KORG	MAIN BOARD	1
*MP5006037	IC MX23C6410MC-10 BK1L KORG	MAIN BOARD	1
*MP5006038	IC SN74AHC32D SOP TYPE	MAIN BOARD	1
*MP5006039	IC SN74AHCT04D SOP TYPE	MAIN BOARD	1
*MP5006040	IC SN74AHCU04D SOP TYPE	MAIN BOARD	2
*MP5006041	IC HT27LC512-90 ERPOM SOP TYPE	MAIN BOARD	1
*MP5006042	IC TC58V64FT SOP TYPE	MAIN BOARD	1
*MP5007001	STEREO JACK ST-015 4PIN DIP	I/F BOARD	6
*MP5007002	STEREO JACK MJ-631 7PIN DIP	I/F BOARD	1
*MP5007003	MIDI JACK DIN-503 5PIN DIP	I/F BOARD	3
*MP5007004	DC JACK DS-210 3PIN DIP	AMP BOARD	1
*MP5008001	CHOKE COIL PLT09H-2003R-004	AMP BOARD	1
*MP5008002	INDUCTANCE CH8090NT-221K-32	LAMP BOARD	1
*MP5010001	POWER SWITCH KDC-A04-10(B)	AMP BOARD	1
*MP5010101	TACT SWITCH TC-0403V-A00	FUNC.CONTROL BOARD	12
*MP5010101	TACT SWITCH TC-0403V-A00	FUNCTION BOARD	70
*MP5010102	TACT SWITCH TC-03XG SMD	LCD CONTROL BOARD	26
*MP5011001	TRANSISTOR BC558C PNP	AMP BOARD	1
*MP5011002	TRANSISTOR D1616A (UTC) NPN	LAMP BOARD	2
*MP5011003	DIGITAL TRANSISTOR C114 E.S.X	FUNCTION BOARD	5
*MP5011003	DIGITAL TRANSISTOR C114 E.S.X	AMP BOARD	1
*MP5011004	TRANSISTOR 2SD2144S NPN	I/F BOARD	4
*MP5011005	TRANSISTOR BC847 SOT-23	LCD BOARD	1
*MP5011006	TRANSISTOR DTA114EKA PNP SMD	FUNC.CONTROL BOARD	8
*MP5011007	TRANSISTOR DTC114EKA NPN SMD	FUNC.CONTROL BOARD	3
*MP5012001	SLIDE POT 10K (DUAL)	FUNCTION BOARD	1
*MP5012002	SLIDE POT 10K (SINGLEL)	FUNCTION BOARD	2
*MP5012003	SLIDE POT 10K (60X8MM)	FUNCTION BOARD	1
*MP5012004	ENCODER 16ENH24A	ENCODER BOARD	1
*MP5012005	VR RK11K114 OADW 10KB	JOYSTICK BOARD	2
*MP5013001	CRYSTAL 16MHZ (HC-49S-SMD)	MAIN BOARD	1
*MP5013002	CRYSTAL 33MHZ (HC-49S-SMD)	MAIN BOARD	1
*MP5013003	CRYSTAL 24.576MHZ (HC-49S-SMD)	MAIN BOARD	1
*MP5014001	EMI FILTER DSS6NF31C223Q55B	I/F BOARD	1
*MP5014001	EMI FILTER DSS6NF31C223Q55B	MAIN BOARD	4
*MP5015001	CERAMIC RESONATOR 16MHZ 3PIN	FUNC.CONTROL BOARD	1
*MP5016001	VERTICAL CONNECTOR 2PINS	LAMP BOARD	1

PART CODE	PART NAME	NOTE	Q'TY
*MP5016001	VERTICAL CONNECTOR 2PINS	LCD BOARD	1
*MP5016002	HORIZONTAL CONNECTOR 3PINS	ENCODER BOARD	1
*MP5016002	HORIZONTAL CONNECTOR 3PINS	FUNC.CONTROL BOARD	1
*MP5016003	HORIZONTAL CONNECTOR 3PINS	JOYSTICK BOARD	1
*MP5016004	VERTICAL CONNECTOR 3PINS	LAMP BOARD	1
*MP5016004	VERTICAL CONNECTOR 3PINS	MAIN BOARD	1
*MP5016005	HORIZONTAL CONNECTOR 4PINS	JOYSTICK BOARD	1
*MP5016006	VERTICAL CONNECTOR 4PINS	AMP BOARD	2
*MP5016007	VERTICAL CONNECTOR 5PINS	MAIN BOARD	1
*MP5016007	VERTICAL CONNECTOR 5PINS	AMP BOARD	1
*MP5016008	HORIZONTAL CONNECTOR 6PINS	FUNCTION BOARD	1
*MP5016009	HORIZONTAL CONNECTOR 6PINS	FUNCTION BOARD	1
*MP5016010	VERTICAL CONNECTOR 6PINS	I/F BOARD	1
*MP5016011	VERTICAL CONNECTOR 7PINS	AMP BOARD	1
*MP5016011	VERTICAL CONNECTOR 7PINS	I/F BOARD	1
*MP5016012	HORIZONTAL CONNECTOR 12PINS	FUNC.CONTROL BOARD	2
*MP5016012	HORIZONTAL CONNECTOR 12PINS	M.PART	2
*MP5016013	VERTICAL MINI CONNECTOR 12PINS	MAIN BOARD	1
*MP5016013	VERTICAL MINI CONNECTOR 12PINS	LCD BOARD	1
*MP5016014	HORIZONTAL MINI CONNECTOR 16P	FUNC.CONTROL BOARD	2
*MP5016015	VERTICAL MINI CONNECTOR 16PINS	MAIN BOARD	1
*MP5016015	VERTICAL MINI CONNECTOR 16PINS	LCD CONTROL BOARD	1
*MP5016016	HORIZONTAL MINI CONNECTOR 20P	FUNCTION BOARD	1
*MP5016016	HORIZONTAL MINI CONNECTOR 20P	FUNC.CONTROL BOARD	1
*MP5016017	VERTICAL MINI CONNECTOR 20PINS	I/F BOARD	1
*MP5016017	VERTICAL MINI CONNECTOR 20PINS	MAIN BOARD	1
*MP5016018	HORIZONTAL MINI CONNECTOR 26P	FUNC.CONTROL BOARD	1
*MP5016018	HORIZONTAL MINI CONNECTOR 26P	FUNCTION BOARD	1
*MP5016019	VERTICAL MINI CONNECTOR 26PINS	I/F BOARD	1
*MP5016019	VERTICAL MINI CONNECTOR 26PINS	MAIN BOARD	1
*MP5016020	VERTICAL CONNECTOR 34PINS	MAIN BOARD	1
*MP5016021	VERTICAL IC SOCKET 3PIN	FUNCTION BOARD	1
*MP5016022	CABLE 2PIN 20# L:400MM	M.PART	1
*MP5016023	CABLE 2PIN 20# L:710MM	M.PART	1
*MP5016024	CABLE 3PIN 24# L:80MM	M.PART	1
*MP5016025	CABLE 12PIN 28# L:190MM	M.PART	1
*MP5016026	CABLE 12PIN 26# L:420MM	M.PART	1
*MP5016027	CABLE 12PIN 26# L:500MM	M.PART	1
*MP5016028	CABLE 16PIN 28# L:240MM	M.PART	2
*MP5016029	CABLE 20PIN 28# L:30MM	M.PART	1
*MP5016030	CABLE 20PIN 28# L:110MM	M.PART	1
*MP5016031	CABLE 26PIN 28# L:30MM	M.PART	1
*MP5016032	CABLE 26PIN 28# L:75MM	M.PART	1
*MP5016033	CABLE 2PIN 24# L:60MM	LAMP BOARD	1
*MP5016034	CABLE 3PIN 22# L:420MM	M.PART	1
*MP5016035	CABLE 6PIN 24# L:710MM	M.PART	1
*MP5016036	CABLE 7PIN 24# L:410MM	M.PART	1
*MP5016037	CABLE 34PIN 28# L:420MM	M.PART	1
*MP5016038	CABLE 6PIN 26# L:260MM	M.PART	1
*MP5016039	CABLE 5PIN 22# L:600MM	M.PART	1
*MP5016040	FLAT CABLE 26# 10PIN L:120MM	M.PART	1

PART CODE	PART NAME	NOTE	Q'TY
*MP5050001	PA-50 PUSHING BUTTON BLACK(12P	M.PART	5
*MP5050002	PA-50 PUSHING BUTTON BLACK(13P	M.PART	1
*MP5050003	PA-50 SQUARE BUTTON,BLACK	M.PART	5
*MP5050004	PA-50 SQUARE BUTTON P=432U	M.PART	2
*MP5050005	PA50 BIG RECTANGLE BUTTON(REDE)	M.PART	1
*MP5050006	PA-50 SMALL RECTANGLE BUTTON	M.PART	4
*MP5050007	PA-50 SMALL RECTANGLE BUTTON	M.PART	3
*MP5050008	PA-50 BIG ELLIPTIC BUTTON(BLK)	M.PART	2
*MP5050009	PA50 SMALL ELLIPTIC BUTTON(BLK	M.PART	9
*MP5050010	PA50 ELLIPTIC BUTTON (BLK+WHT)	M.PART	1
*MP5050011	PA-50 ROUND BUTTON BLACK+WHITE	M.PART	2
*MP5050012	PA-50 JOYSTICK RUBBER HANDLE	M.PART	1
*MP5050013	RUBBER PUSHING BUTTON BLACK	M.PART	5
*MP5050014	618 KEYBOARD CONDUCTIVE RUBBER	M.PART	5
*MP5050015	PA-50 ZEBRA CONNECTOR	LCD BOARD	2
*MP5050016	PA-50 VELVET FELT SIZE:8X1.0MM	M.PART	2
*MP5050017	PA-50 LENS SHIELD FILM	M.PART	1
*MP5050018	PA-50 FOAM RUBBER 11X38X2MM	M.PART	3
*MP5050019	PA-50 FOAM RUBBER 40X40X2MM	M.PART	1
*MP5050020	PA-50 FOAM RUBBER 140X40X1.5MM	M.PART	1
*MP5050021	PA-50 FOAM RUBBER 315X15X2.5MM	M.PART	2
*MP5050022	BLK VELVET W/A 828X10X3MM	M.PART	1
*MP5050023	PA-50 FOAM RUBBER 830X12X1.2MM	M.PART	1
*MP5050024	PA-50 FOAM RUBBER 1400X13X1MM	M.PART	2
*MP5050025	BLACK VELECT SIZE 16X14X0.3MM	M.PART	1
*MP5050026	PA-50 RUBBER STAND T:4MM	M.PART	2
*MP5050027	PA-50 RUBBER STAND T:5MM	M.PART	4
*MP5050028	PA-50 GREY SPONGE 70X25X3MM	M.PART	1
*MP5050029	PA-50 GREY SPONGE 170X30X3MM	M.PART	2
*MP5050030	PA-50 SPONGE SIZE 170X153X4MM	M.PART	2
*MP5050031	WK-1 GREY SPONGE 220X60X3MM	M.PART	1
*MP5050032	PA-50 GREY SPONGE 230X35X3MM	M.PART	1
*MP5050033	PA-50 SPONGE 1 (R)285X160X35MM	M.PART	1
*MP5050034	PA-50 SPONGE 2 (R)285X230X35MM	M.PART	1
*MP5050035	PA-50 GREY SPONGE 360X25X3MM	M.PART	1
*MP5050036	PA-50 SPONGE 1 (L)360X165X35MM	M.PART	1
*MP5050037	PA-50 SPONGE 2 (L)360X235X35MM	M.PART	1
*MP5050038	PA-50 GREY SPONGE 390X30X3MM	M.PART	1
*MP5050039	PA-50 GREY SPONGE 400X25X3MM	M.PART	1
*MP5050040	PA-50 GREY SPONGE 400X90X3MM	M.PART	1
*MP5050041	PA-50 GREY SPONGE 570X30X3MM	M.PART	1
*MP5050042	PA-50 GREY SPONGE 670X253MM	M.PART	2
*MP5050044	PA-50 HEAT SINK H=26MM	AMP BOARD	1
*MP5050045	GK-350 LEFT DISK DRIVER HOLDER	M.PART	1
*MP5050046	GK350 RIGHT DISK DRIVER HOLDER	M.PART	1
*MP5050047	PA-50 JS SPRING DIA:11.3X1.0MM	M.PART	2
*MP5050048	PA-50 BRACKET FOR LCD	LCD BOARD	1
*MP5050049	PA-50 MUSIC STANDS BLACK	M.PART	1
*MP5050050	PA-50 JACK BOARD BRACKET	M.PART	1
*MP5050051	PA-50 MAIN BOARD UPPER SHIELD	MAIN BOARD	1
*MP5050052	PA-50 MAIN BOARD LOWER SHIELD	MAIN BOARD	1

PART CODE	PART NAME	NOTE	Q'TY
*MP5050053	PA-50 HEAT SINK SILVERY WHITE	AMP BOARD	1
*MP5050054	PA-50 SPEAKER MESH LEFT	M.PART	1
*MP5050055	PA-50 SPEAKER MESH RIGHT	M.PART	1
*MP5050056	WASHER OF DISK DRIVE H:6.5MM	M.PART	4
*MP5050057	PA-50 JS SPRING WASHER	M.PART	2
*MP5050058	PA-50 LCD BRACKET ABS WHITE	LCD BOARD	1
*MP5050059	PA-50 LED SOCKET HOLDER BLACK	FUNCTION BOARD	32
*MP5050059	PA-50 LED SOCKET HOLDER BLACK	FUNC.CONTROL BOARD	9
*MP5050060	PA-50 LCD COVER ABS WHITE	LAMP BOARD	1
*MP5050061	PA-50 MUSIC STAND BRACKET	M.PART	2
*MP5050062	PA-50 JOYSTICK BRACKET	M.PART	1
*MP5050063	PA-50 LCD LENS	LCD CONTROL BOARD	1
*MP5050064	PA-50 LCD DIFFUSER	LCD BOARD	1
*MP5050065	PA-50 LCD LIGHT GUIDE	LCD BOARD	1
*MP5050066	PA-50 LCD CASE	LCD CONTROL BOARD	1
*MP5050067	PA-50 BASS REFLEX TUBE	M.PART	2
*MP5050068	PA-50 BOTTOM CABINET BLACK	M.PART	1
*MP5050069	PA-50 TOP CABINET BLACK	M.PART	1
*MP5050070	PA-50 POWER SWITCH KNOB BLACK	M.PART	1
*MP5050071	PA-50 VOLUME SWITCH CAP BLACK	M.PART	4
*MP5050072	PA-50 ENCODER KNOB BLACK	M.PART	1
*MP5050073	PA-50 JOYSTICK-TURN SHELF	M.PART	1
*MP5050074	PA-50 JOYSTICK-FIXING BRACKET	M.PART	1
*MP5050075	PA-50 JOYSTICK-BAFFLE BOARD	M.PART	1
*MP5050076	PA-50 JOYSTICK-TURNTABLE	M.PART	1
*MP5070001	PA-50 SPEAKER BOX PANEL-LEFT	M.PART	1
*MP5070002	PA-50 SPEAKER BOX PANEL-RIGHT	M.PART	1
*MP5070003	PA-50 LCD BLUE FILTER	LCD BOARD	1
*MP5090006	AC CORD 1.5 M CCC 220CH	M.PART	1
*MP5090007	AC CORD 023-B001 1.5M 230UK	M.PART	1
*MP5090008	AC CORD 023-S022 1.5M 240AU	M.PART	1
*MP5090009	AC CORD 023-V019 1.5M 230V	M.PART	1
*MP5090010	AC CORD 023-U087 1.5M 117V	M.PART	1