

TT100

Service Information

Laney
Classic British Amplification

Newlyn Road, Cradley Heath, West Midlands. B64 6BE
www.laney.co.uk

TT100

Service Information

Contents

- 1. Contents**
- 2. TT100 combo Schematic drawing**
- 3. TT100 combo Mains wiring**
- 4. Tone Control Pcb - 9355 issue 3**
- 5. Tone Control Pcb - 9355 issue 4**
- 6. Main Preamp Pcb - 9356 issue 3**
- 7. Main preamp Pcb - 9356 issue 4**
- 8. Tube Pcb - 9357 issue 3**
- 9. Tube Pcb - 9357 issue 4**
- 10. TT midi Pcb - 9358 issue 4**

Laney

Classic British Amplification

Newlyn Road, Cradley Heath, West Midlands. B64 6BE
www.laney.co.uk

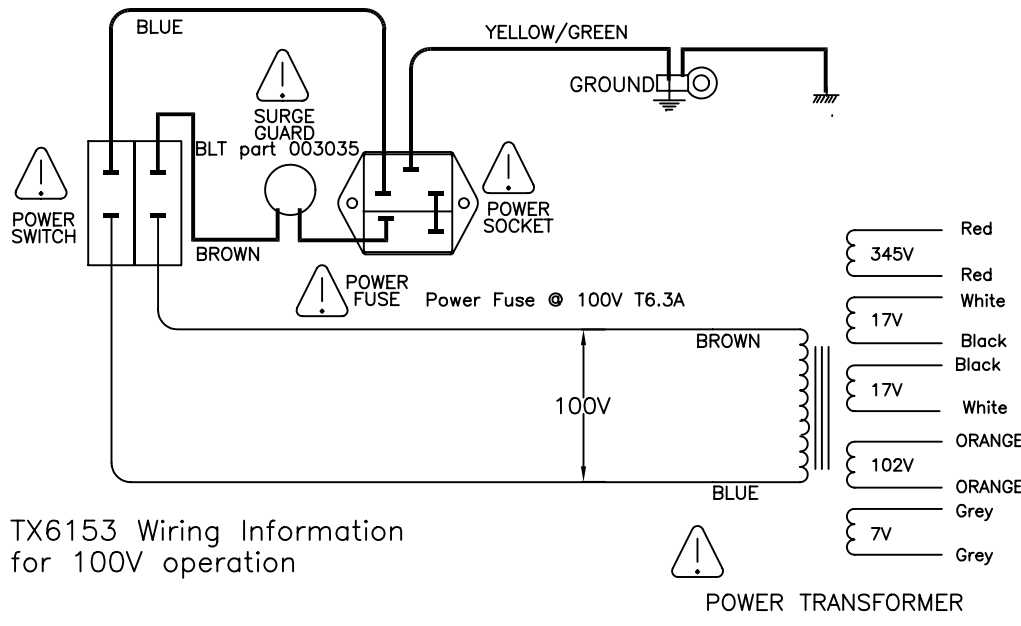
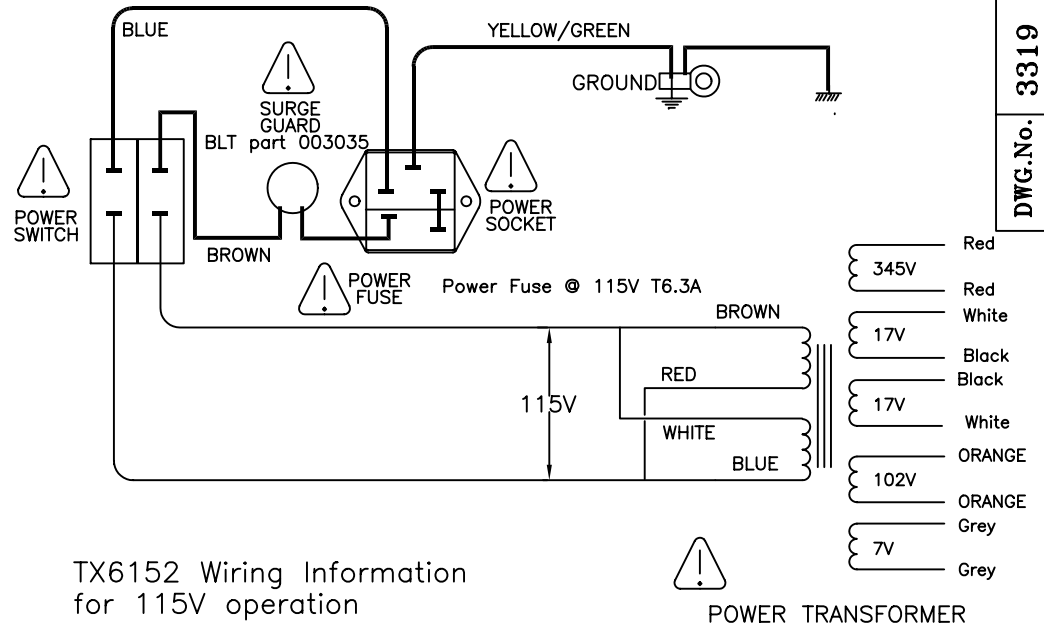
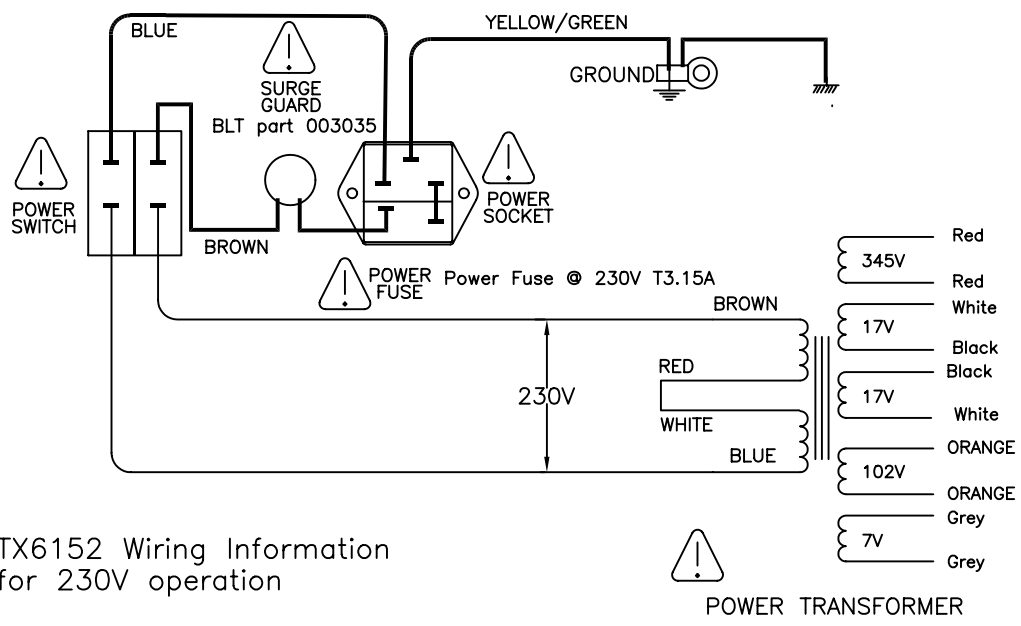

⚠ = ONLY REPLACE WITH SAME TYPE AND RATING

ISSUE	DESCRIPTION	APPD.	DATE	TITLE	DRAWN	TRACED	CHECKED	APPROVED	DATE
				BLT Industries Ltd. MAINS WIRING FOR TT100 combo and TT100H PART No	R.J.F				29/04/02
					DRAWING No.		3319		

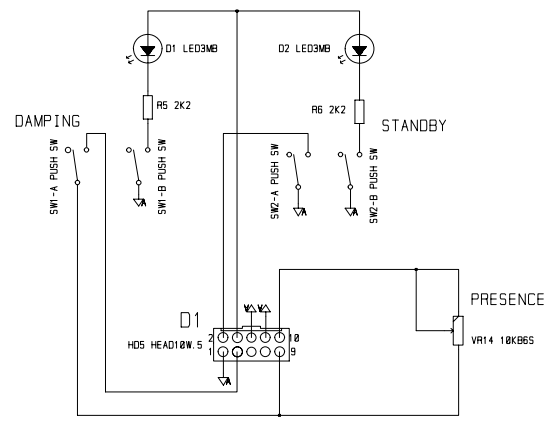
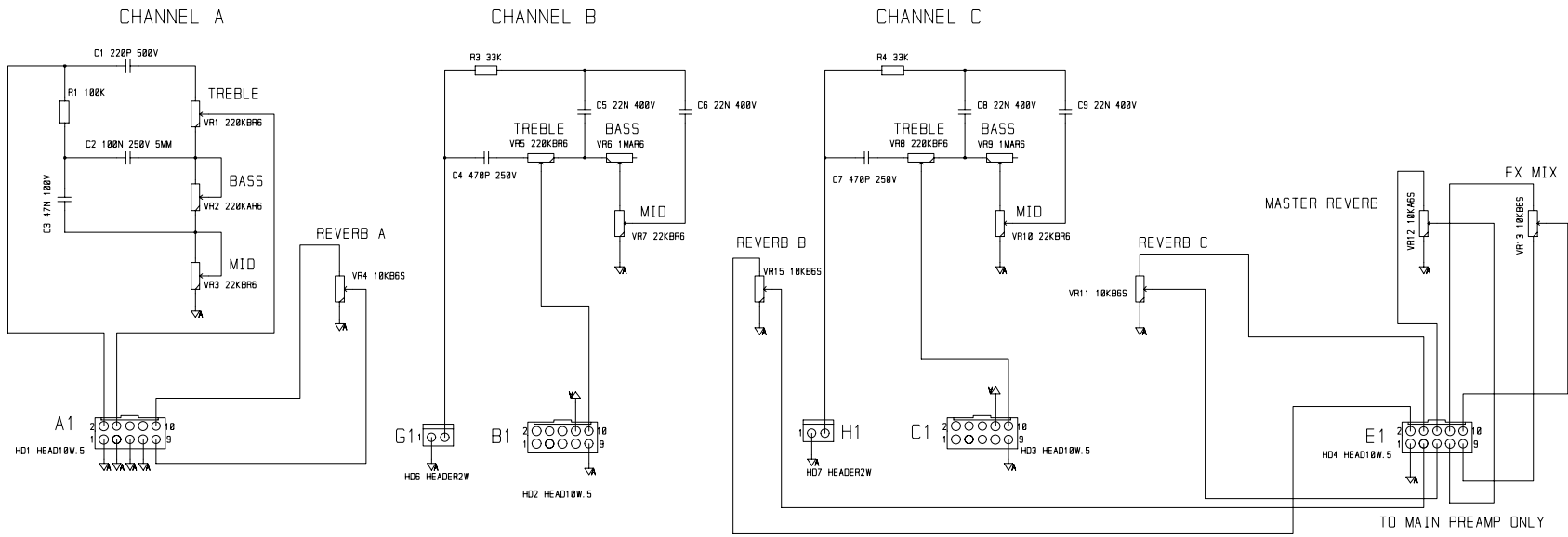

DRAWN	DEH
DATE	13/02/02
TITLE	TT50/100 TONE CONTROLS
DRW. NO.	9355_3

ISSUE							
TYPE							

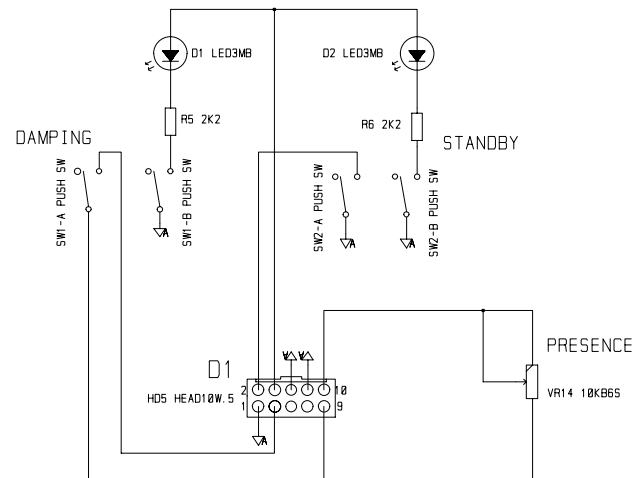
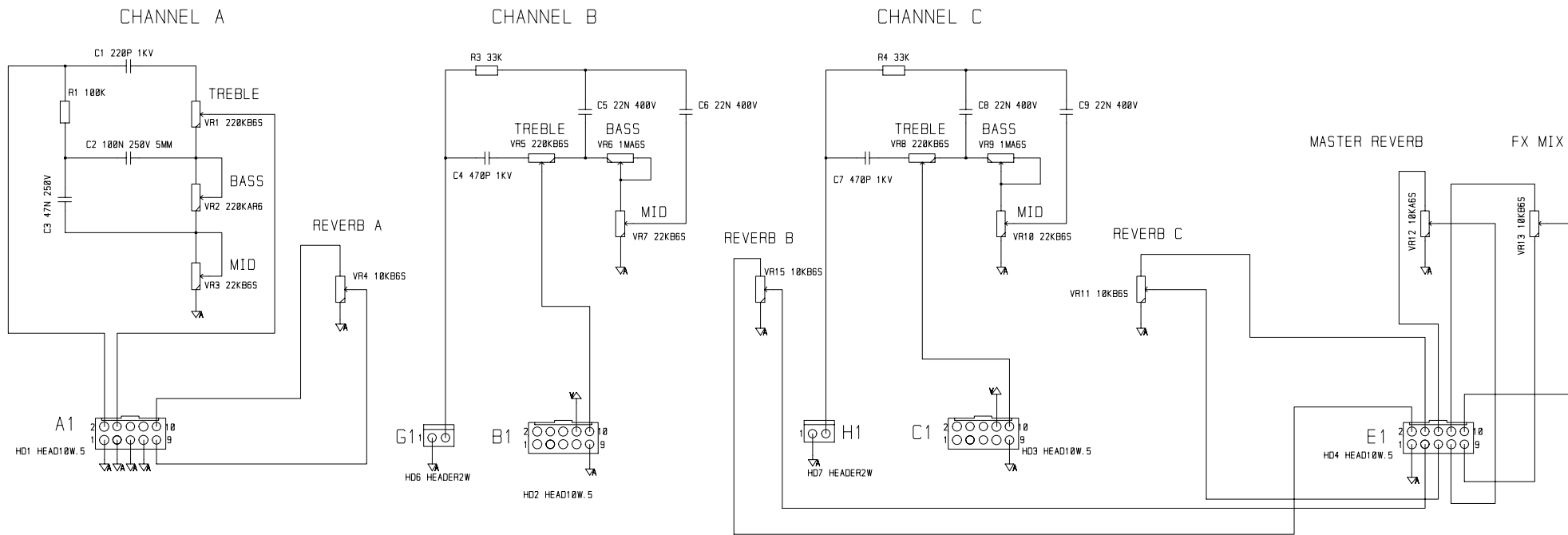

DRAWN	DEH
DATE	17/04/02
TITLE	TT50/100 TONE BOARD
DRW. NO.	9355_4

ISSUE							
TYPE							

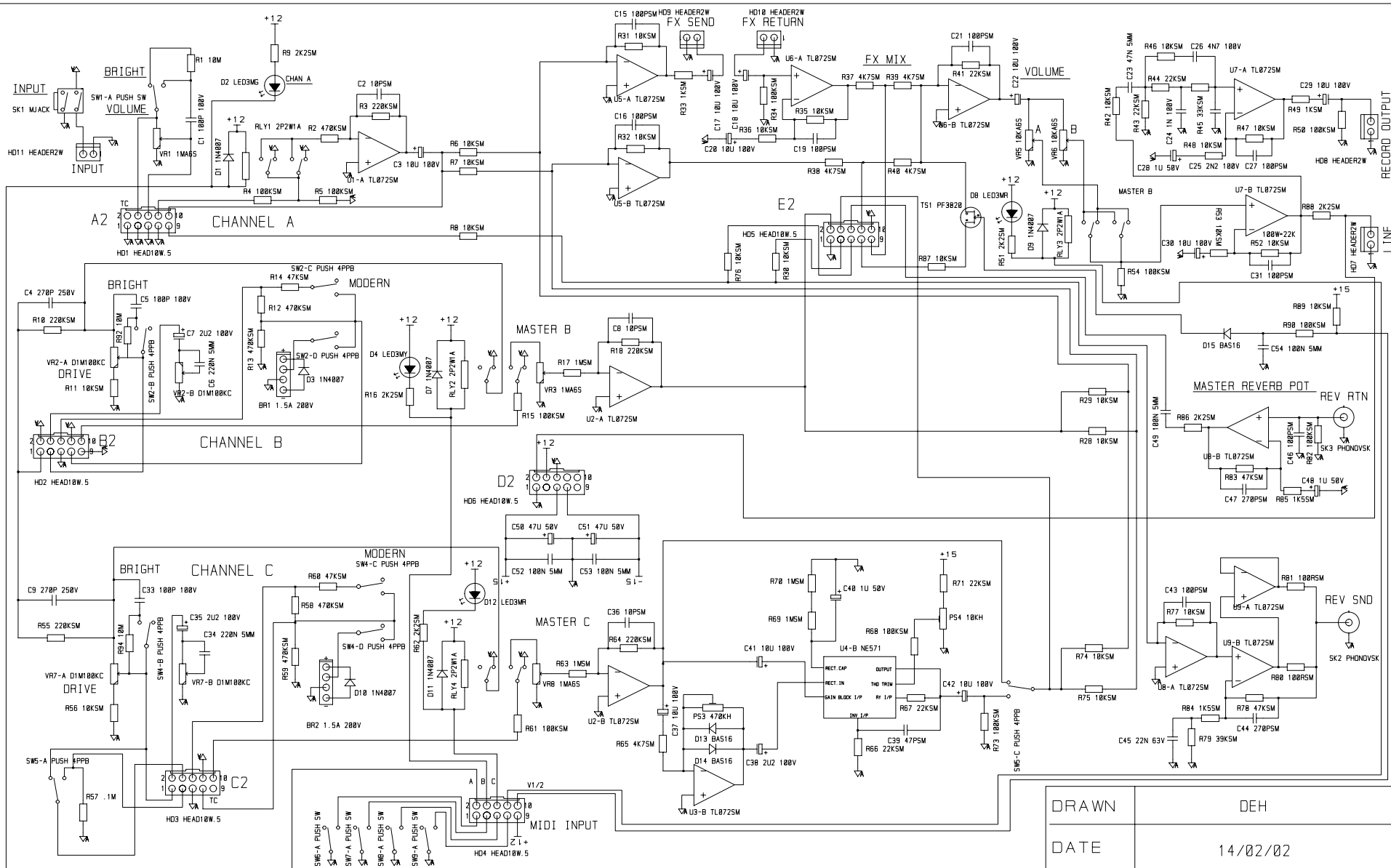

DRAWN	DEH
DATE	14/02/02
TITLE	TT50/100 MAIN PREAMP
DRW. NO.	9356.13

ISSUE	
TYPE	

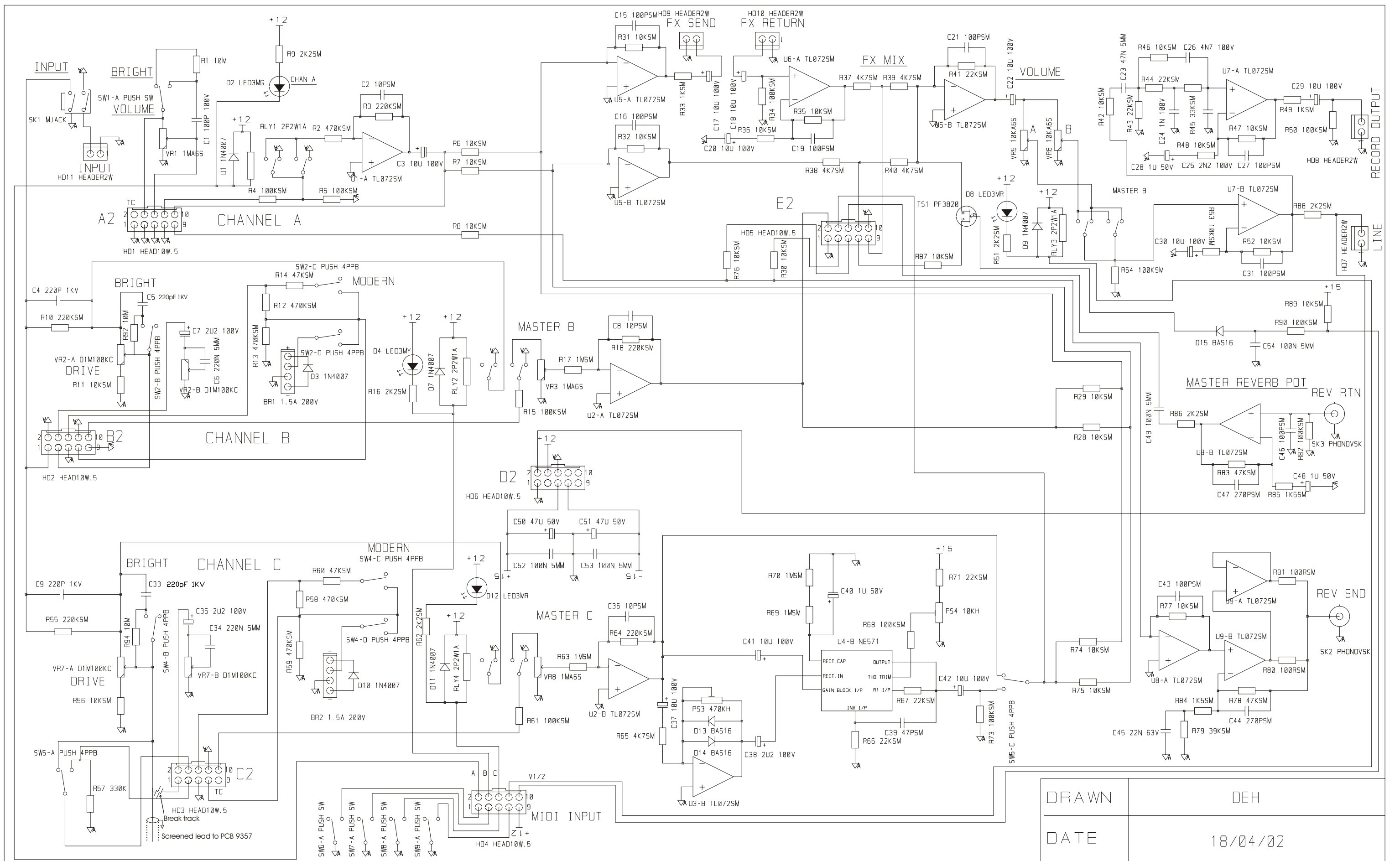

DRAWN	DEH
DATE	18/04/02
TITLE	TT50/100 MAIN PREAMP
DRW. NO.	9356_4

ISSUE	4
TYPE	- C5 from 100pF to 220pF 1KV - C33 from 100pF to 220pF 1KV - Track break on pin1 of HD3 - Screened lead wired from Wiper VR7 to PCB 9357. (See CN0335 20/01/04)

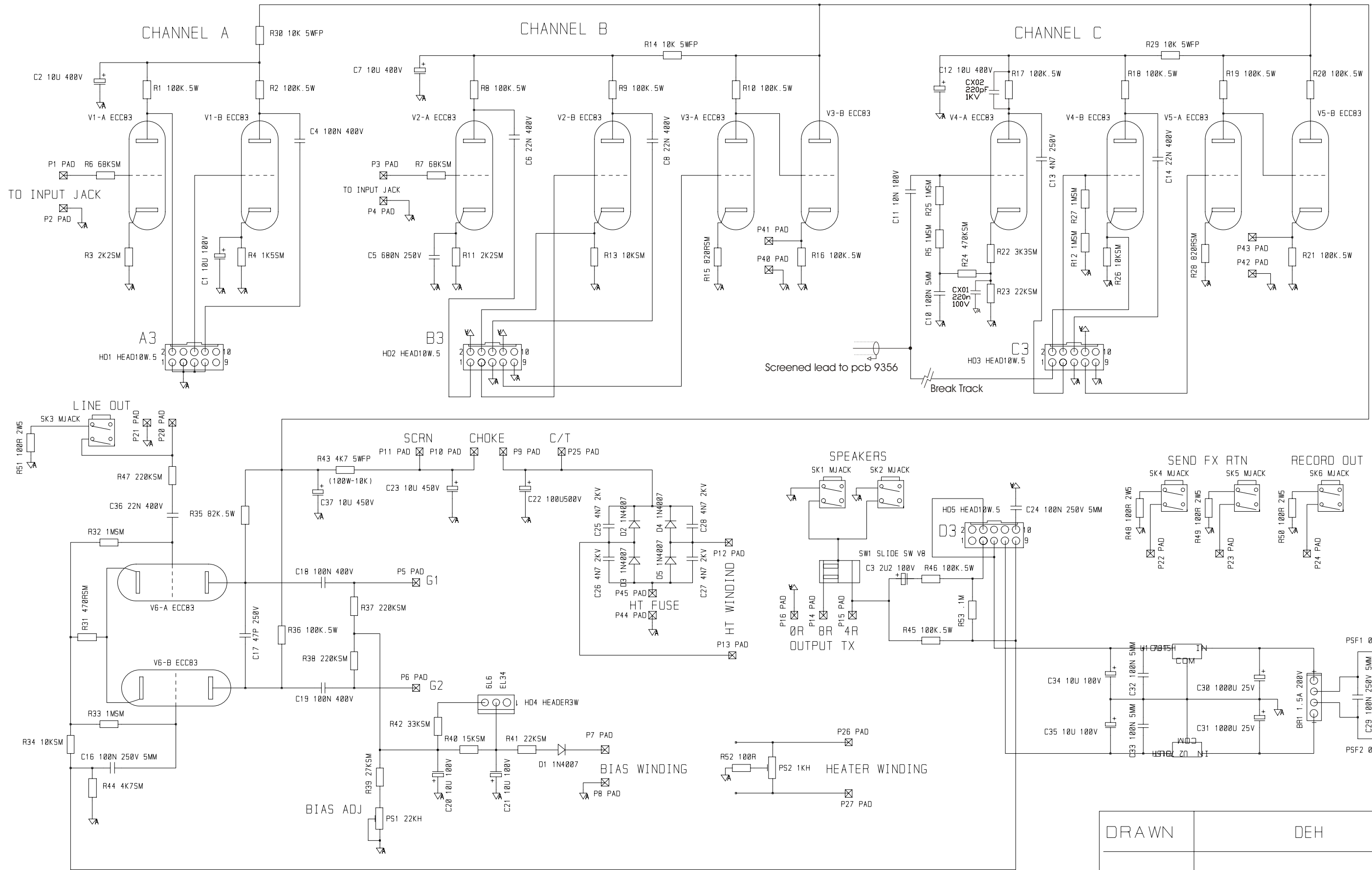

DRAWN	DEH
DATE	19/04/02
TITLE	TT50 MAIN BOARD
DRW. NO.	9357_4

ISSUE	4
TYPE	- CX01, CX02 Added - Track broken by pin1 HD3 - Screened lead added from pcb 9356 to C11. (See CN0335 20/01/04)

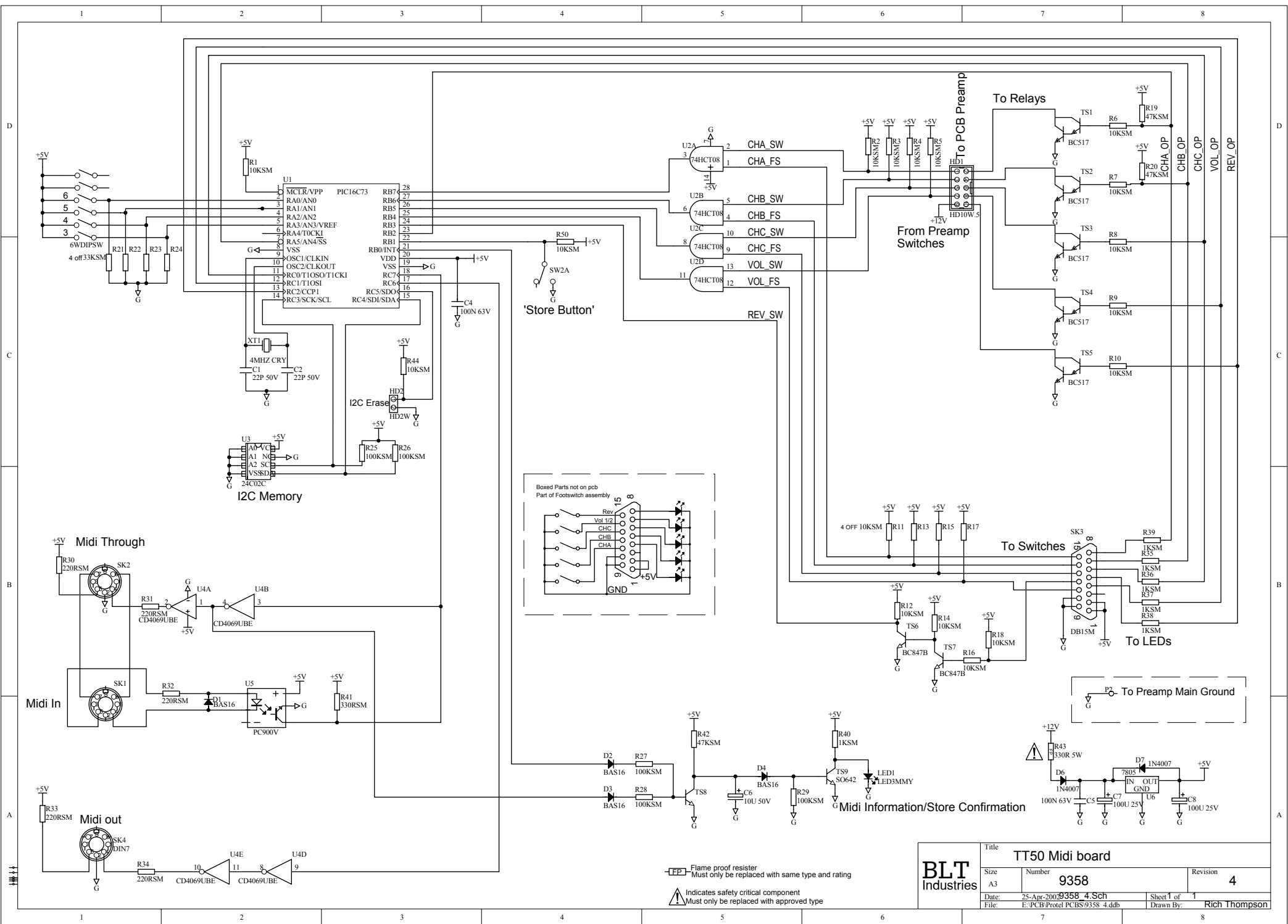

Flame proof resistor
 Must only be replaced with same type and rating
 Indicates safety critical component
 Must only be replaced with approved type

BLT Industries		Title TT50 Midi board	
Size A3	Number 9358	Revision 4	
Date 25-Apr-2002 9358 4.Sch		Sheet 1 of 1	
File E:\PCB\Protel\PCBS\9358 4.ddb		Drawn By: Rich Thompson	