

ECOs INCLUDED ON THIS SCHEMATIC/PCB REVISION		
ECO NO:	DATE:	DESCRIPTION:
223801	10/22/02	REMOVE R12 & R23 PER ECO

THE INFORMATION CONTAINED IN THIS DRAWING IS THE SOLE PROPERTY OF LINE 6 INC. ANY REPRODUCTION IN PART OR WHOLE WITHOUT THE WRITTEN PERMISSION OF LINE 6 INC. IS PROHIBITED

COMPANY:	LINE 6	
TITLE:	FBC MAIN PCB	
PROGRAM:	PADS POWER LOGIC V4.0	REV: B1
FILENAME:	g:/CLIENTS/FFD/Floor Board Product Family/FBC	
SCALE: 1:1	SIZE: C	PART NUMBER: 35-00-0142
SHEET: 1		OF 3

DRAWN:	T. BURTON/db	DATED:	10/22/02
CHECKED:		DATED:	Date

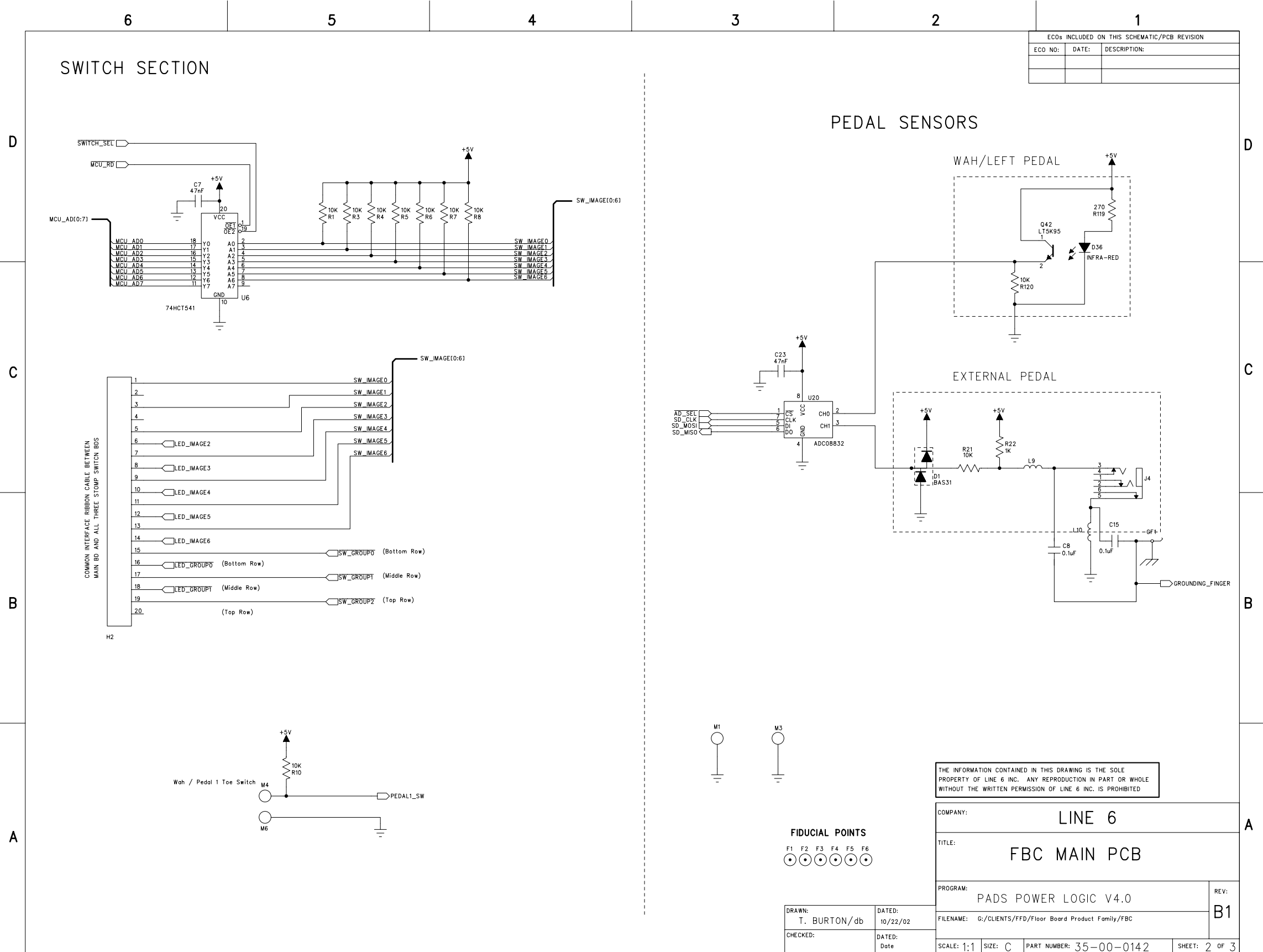

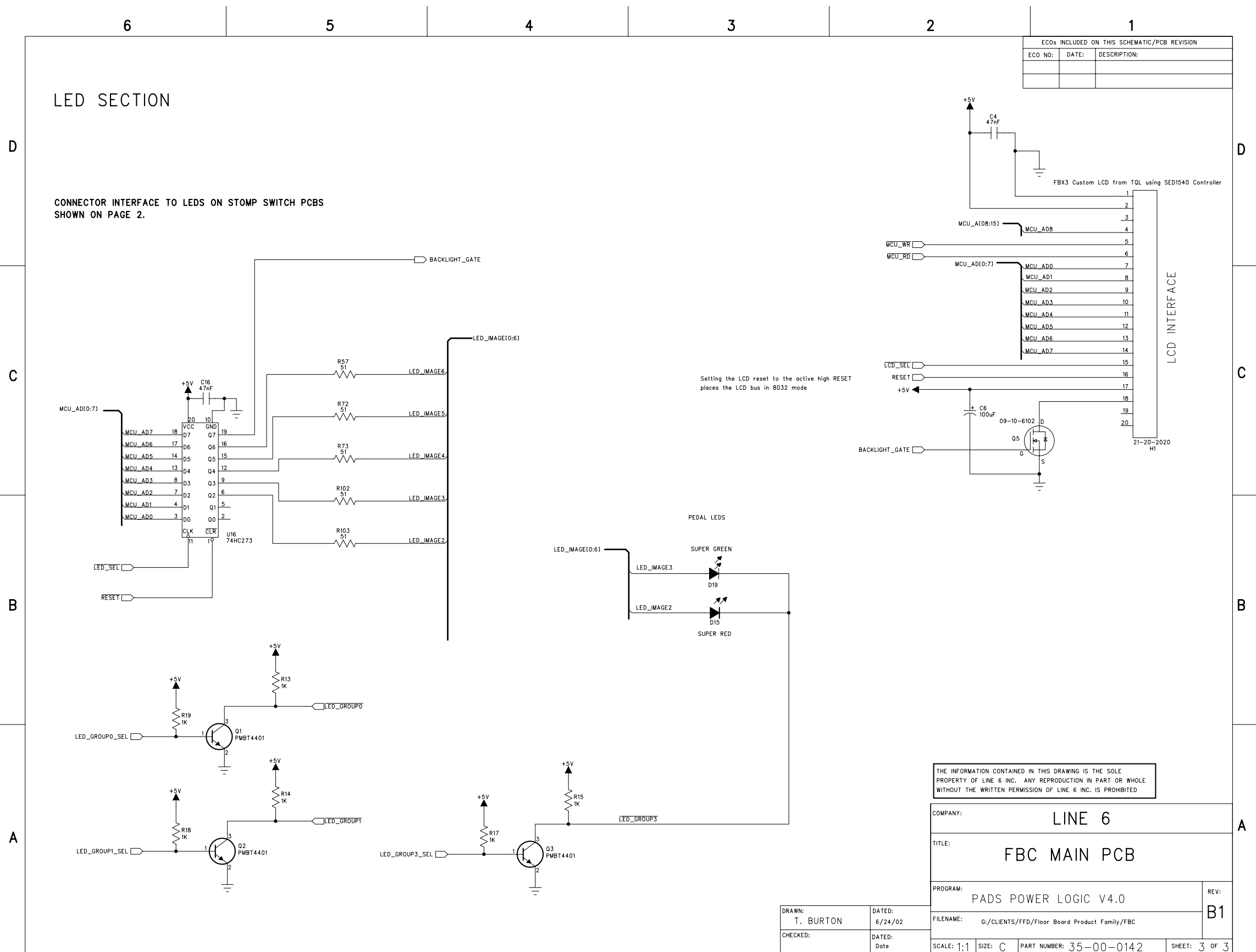

ECOs INCLUDED ON THIS SCHEMATIC/PCB REVISION		
ECO NO:	DATE:	DESCRIPTION:

THE INFORMATION CONTAINED IN THIS DRAWING IS THE SOLE PROPERTY OF LINE 6 INC. ANY REPRODUCTION IN PART OR WHOLE WITHOUT THE WRITTEN PERMISSION OF LINE 6 INC. IS PROHIBITED

COMPANY:		LINE 6	
TITLE:		FBC MAIN PCB	
PROGRAM:	PADS POWER LOGIC V4.0	REV:	B1
FILENAME:	G:/CLIENTS/FFD/Floor Board Product Family/FBC	SCALE:	1:1
DRAWN:	T. BURTON	DATED:	6/24/02
CHECKED:		DATED:	
PART NUMBER:		35-00-0142	
SHEET:		3 OF 3	

DRAWN:	T. BURTON	DATED:	6/24/02
CHECKED:		DATED:	

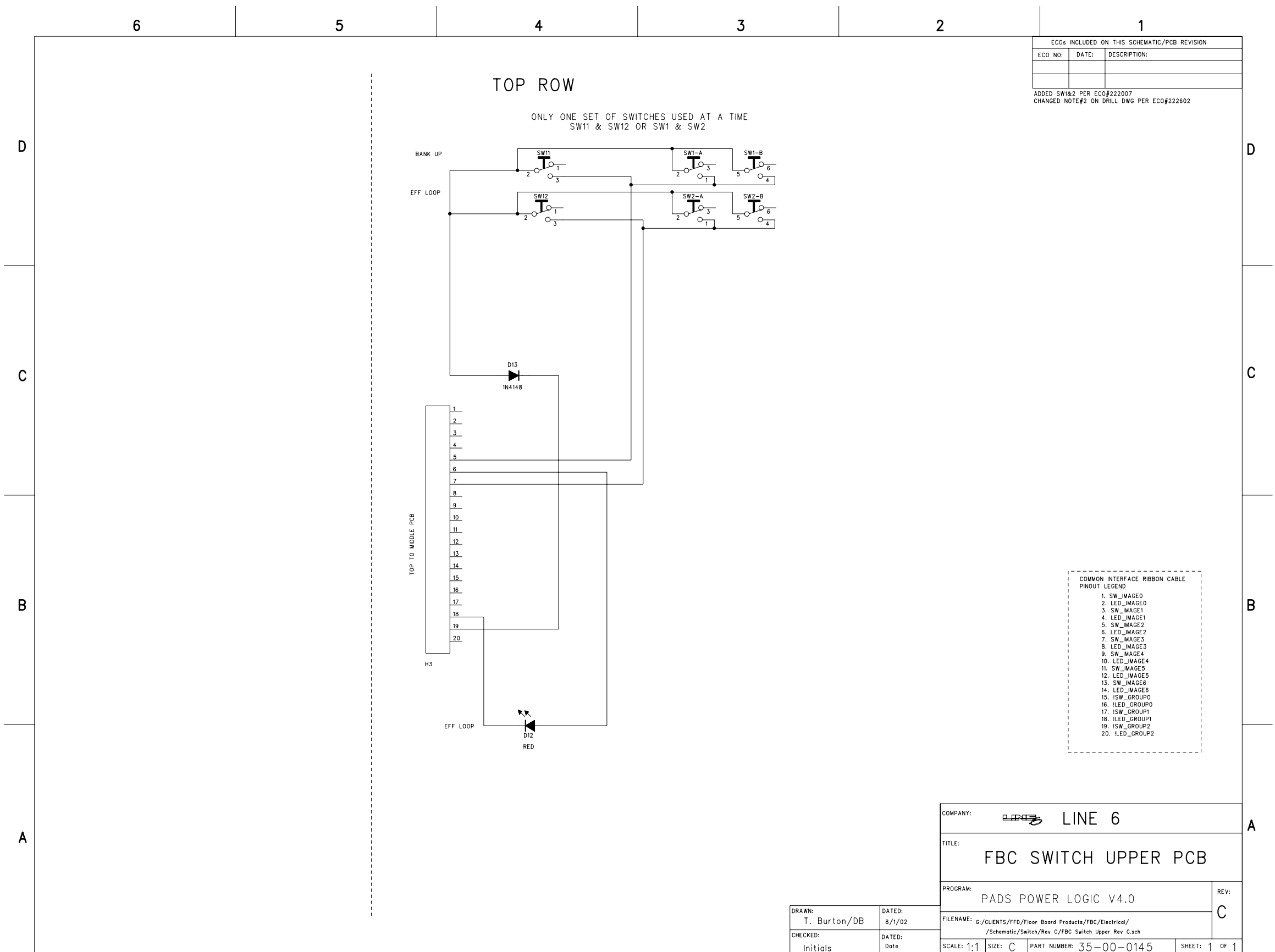

ECOs INCLUDED ON THIS SCHEMATIC/PCB REVISION		
ECO NO:	DATE:	DESCRIPTION:

ADDED SW1&2 PER ECO#222007
CHANGED NOTE#2 ON DRILL DWG PER ECO#222602

COMPANY: LINE 6		REV: C
TITLE: FBC SWITCH UPPER PCB		
PROGRAM: PADS POWER LOGIC V4.0		SHEET: 1 OF 1
FILENAME: g:/CLIENTS/FFD/Floor Board Products/FBC/Electrical/ /Schematic/Switch/Rev C/FBC Switch Upper Rev C.sch		
DRAWN: T. Burton/DB	DATED: 8/1/02	SCALE: 1:1
CHECKED: Initials	DATED: Date	SIZE: C
PART NUMBER: 35-00-0145		

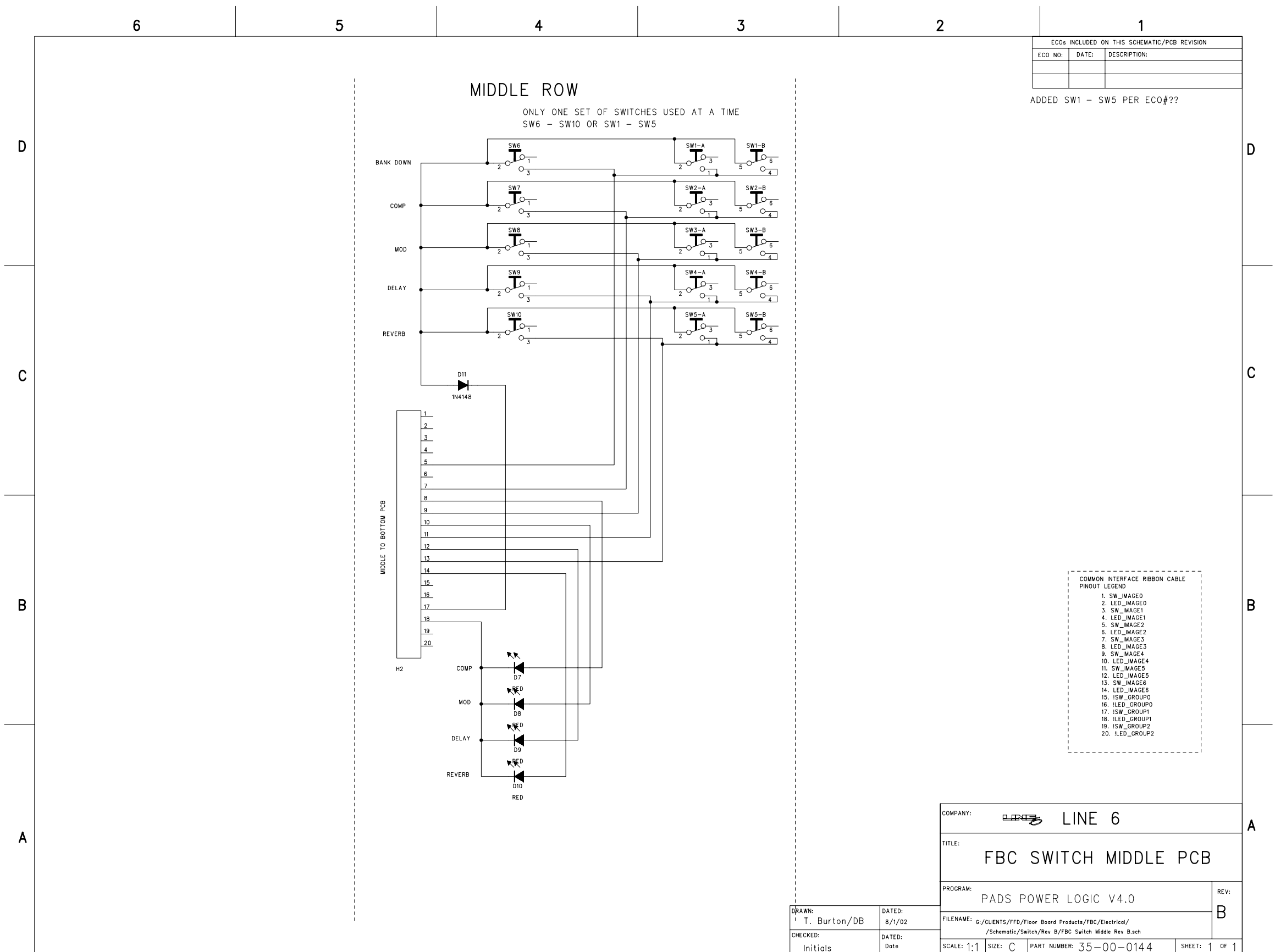

COMPANY: LINE 6	
TITLE: FBC SWITCH MIDDLE PCB	
PROGRAM: PADS POWER LOGIC V4.0	REV: B
FILENAME: g:\CLIENTS\FPD\Floor Board Products\FBC\Electrical/ /Schematic/Switch/Rev B/FBC Switch Middle Rev B.sch	
DRAWN: T. Burton/DB	DATED: 8/1/02
CHECKED: Initials	DATED: Date
SCALE: 1:1	SIZE: C
PART NUMBER: 35-00-0144	SHEET: 1 OF 1

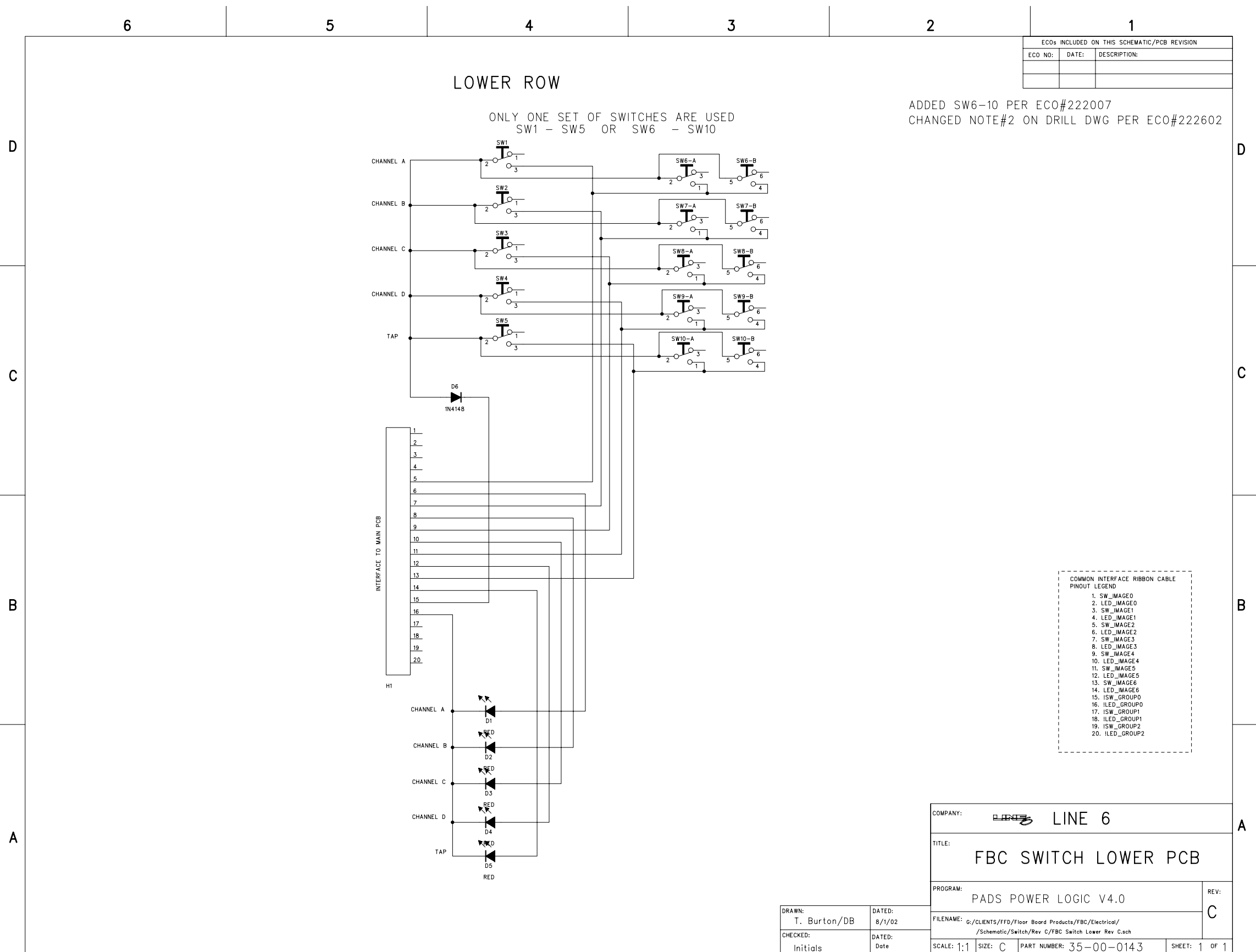

ECOs INCLUDED ON THIS SCHEMATIC/PCB REVISION		
ECO NO:	DATE:	DESCRIPTION:

ADDED SW6-10 PER ECO#222007
 CHANGED NOTE#2 ON DRILL DWG PER ECO#222602

COMMON INTERFACE RIBBON CABLE PINOUT LEGEND	
1.	SW_IMAGE0
2.	LED_IMAGE0
3.	SW_IMAGE1
4.	LED_IMAGE1
5.	SW_IMAGE2
6.	LED_IMAGE2
7.	SW_IMAGE3
8.	LED_IMAGE3
9.	SW_IMAGE4
10.	LED_IMAGE4
11.	SW_IMAGE5
12.	LED_IMAGE5
13.	SW_IMAGE6
14.	LED_IMAGE6
15.	ISW_GROUP0
16.	ILED_GROUP0
17.	ISW_GROUP1
18.	ILED_GROUP1
19.	ISW_GROUP2
20.	ILED_GROUP2

COMPANY:	LINE 6	REV:	C
TITLE:	FBC SWITCH LOWER PCB		
PROGRAM:	PADS POWER LOGIC V4.0	REV:	C
DRAWN:	T. Burton/DB	DATED:	8/1/02
CHECKED:	Initials	DATED:	Date
FILENAME:	g:\CLIENTS\FPD\Floor Board Products\FBC\Electrical/Schematic/Switch/Rev C\FBC Switch Lower Rev C.sch		
SCALE:	1:1	SIZE:	C
PART NUMBER:	35-00-0143	SHEET:	1 OF 1

LINE 6
FBV Shortboard Parts List

Level	Part #	Component-Description								Qty-Per-Parent
=====										
Parent Item: 59-040-0901 FBC										
1	10	21-30-0023 CAB DIL RIBBON 20-PIN 1.25mm 708mm IDC x 4	10	EA	.0	A	Y	N	1.000000	
1	20	21-30-0024 CAB DIL RIBBON 20-PIN 1mm 226.06mm IDC-IDC	10	EA	.0	A	Y	N	1.000000	
1	30	30-00-0012 SCREW 1/4-20 x3.5IN STEEL SHCS BLK OXIDE	10	EA	.0	A	Y	N	1.000000	
1	40	30-00-0013 SCREW 6-32 x.25in STL PNH PHH BLK OXIDE	10	EA	.0	A	Y	N	4.000000	
1	60	30-00-1632 SCR 6-32x3/8 PNH PHH TAP TITE STL BLK	10	EA	.0	A	Y	N	10.000000	
1	70	30-00-1633 SCR, 6-32 x 3/8 LG, PHILLIPS P PPZ W/LockWasher	10	EA	.0	A	Y	N	2.000000	
1	80	30-03-0003 WASHER .473 x.260x .030 steel	10	EA	.0	A	Y	N	4.000000	
1	90	30-03-0005 WASHER .500 x.260x .030 NYLON	10	EA	.0	A	Y	N	2.000000	
1	100	30-03-0007 WASHER .500 x.260x .125 NYLON	10	EA	.0	A	Y	N	2.000000	
1	110	30-03-0013 WASHER .50 x.170x .040 NYLON	10	EA	.0	A	Y	N	2.000000	
1	120	30-03-0014 WASHER NO.6 FINISHING	10	EA	.0	A	Y	N	12.000000	
1	130	30-03-0017 WASHER 15.9 x11.9x .53mm STEEL NICKEL	10	EA	.0	A	Y	N	12.000000	
1	140	30-06-0008 NUT 4mm PUSH NUT STEEL ZINC	10	EA	.0	A	Y	N	12.000000	
1	150	30-06-0009 NUT 1/4-20 STL W/NYLON LOCK	10	EA	.0	A		N	1.000000	
1	160	30-06-0623 NUT 6-32 W/CAPTV-STAR-WASHER	10	EA	.0	A	Y	N	2.000000	
1	170	30-15-0005 SPACER .25ID x NO.8 OD AL	10	EA	.0	A	Y	N	2.000000	

LINE 6
FBV Shortboard Parts List

1	180 30-15-0006	INSULATOR .17 ODx.46 LG PLASTIC	10 EA	.0 A Y N	2.000000
1	190 30-15-0011	SPACER .39 Dia x 2.40 Lg Al or Stl	10 EA	.0 A Y N	1.000000
1	200 30-27-0030	BEZEL FBX3 1.4x7.0 H IMP ABS SM MICROTTEXTURE	10 EA	.0 A Y N	1.000000
1	210 30-27-0037	LENS BEZEL FBX3 6.5x.95 LEXAN CLEAR	10 EA	.0 A Y N	1.000000
1	220 30-27-0038	LT PIPE DIVERG .55IN X .16DIA LEXAN 141 HIGHLY POLISHED	10 EA	.0 A Y N	12.000000
1	230 30-48-5012	BUMPER RBR .465" O.D. BLK FLOORBOARD	10 EA	.0 A Y N	8.000000
1	240 30-51-0046	BRACKET PEDAL .85x2.54" 16 GA STL EG	10 EA	.0 A Y N	1.000000
1	250 30-51-0077	SUPPORT CORRUGATED 1.9x7.5IN 20GA EG STL	10 EA	.0 A Y N	1.000000
1	260 30-51-0078	TACTILE DOME 20mm SST NP	10 EA	.0 A Y N	3.000000
1	270 30-51-0085	PEDAL 8.0x3.1 16 GA EGS NKL PL	10 EA	.0 A Y N	1.000000
1	290 30-51-0106	CHASSIS BASE 18.2 x 7.8 x 2.0 18 GA EG STL	10 EA	.0 A Y N	1.000000
1	310 30-75-0002	FOOT RUBBER 2.87x7.70x.237 BLK	10	.0 A N	1.000000
1	320 30-75-0007	PEDAL STOP FOAM RUBBER 2.63x.25x.06	10 EA	.0 A Y N	1.000000
1	325 30-75-0011	STOP PEDAL RBR .81SQ x .52 BLK	10 EA	.0 A Y N	2.000000
1	340 50-00-0092	PCBA DISPLAY LCD FBV shortboard	1	.0 A Y N	1.000000
2	10 18-30-0001	DISPLAY LCD - FBV Shortboard TQL001TPL	10 EA	.0 A Y N	1.000000
2	20 21-20-1011	Ref: LCD Display HDR PCB MT DIL 20-PIN 2x10x2mm MALE VERT MT TH	10 EA	.0 A Y N	1.000000
1	350 50-00-0142	Ref: LCD Display PCBA MAIN FBV Shortboard	10 EA	.0 A	1.000000

LINE 6
FBV Shortboard Parts List

2	10 01-00-0101	RES 100R 5% 0805	0 EA	.0	A Y N	1.000000
		Ref: R2				
2	20 01-00-0102	RES 1K 5% 0805	0 EA	.0	A Y N	8.000000
		Ref: R13-15,R17-19,R22,r25				
2	30 01-00-0103	RES 10K 5% 0805	0 EA	.0	A Y N	11.000000
		Ref: R1,R3-8,R10,R21,R24,R120				
2	40 01-00-0271	RES 270R 5% 0805	0 EA	.0	A Y N	1.000000
		Ref: R119				
2	50 01-00-0510	RES 51R 5% 0805	0 EA	.0	A Y N	5.000000
		Ref: R57,R72-73,R102-103				
2	60 03-10-0107 6.3/8/5	CAP ELEC 100uF 10V 20% RADIAL	0 EA	.0	A Y N	1.000000
		Ref: C6				
2	70 03-18-0106 5/11/5	CAP ELEC 10uF 50V 20% RADIAL	0 EA	.0	A Y N	2.000000
		Ref: C22,C26				
2	80 03-50-0220	CAP NPO 22pF 50V 20% 0805	0 EA	.0	A Y N	4.000000
		Ref: C2-3,C27-28				
2	90 03-52-0102	CAP X7R 1nF 50V 20% 0805	0 EA	.0	A Y N	5.000000
		Ref: C9,C11,C13-14,C76				
2	100 03-52-0104	CAP X7R 0.1uF 50V 20% 0805	0 EA	.0	A Y N	4.000000
		Ref: C8,C10,C12,C15				
2	110 03-52-0473	CAP X7R 47nF 50V 20% 0805	0 EA	.0	A Y N	10.000000
		Ref: C1,C4-5,C7,C16,C19,C21,C23,C25,C101				
2	120 06-20-0099 6nS SOT-23 SM BAV99	DIODE GEN PUR DUAL 70V 215mA	0 EA	.0	A Y N	1.000000
		Ref: D1				
2	130 09-10-4401 SOT-23 SM	TRANS NPN SMALL-SIGNAL MBT4401	0 EA	.0	A Y N	4.000000
		Ref: Q1-3,Q6				
2	140 09-10-6102 ZX61N02 SOT-23 SM	TRANS N-CHANNEL MOSFET	0 EA	.0	A Y N	1.000000
		Ref: Q5				

LINE 6
FBV Shortboard Parts List

2	150 09-20-0095	PHOTOTRANSISTOR, SMD Blue Lens Ledtech LT5K95-AA-0125	0 EA	.0	A	Y	N	1.000000
		Ref: Q42						
2	160 11-00-1197	CRYSTAL 11.9808MHZ 3-PIN W/GND HC49/U TH	0 EA	.0	A	Y	N	1.000000
		Ref: Y1						
2	170 11-10-0501	FERRITE BEAD 500R @100mHZ 2.5A 1206 SM	0 EA	.0	A	Y	N	2.000000
		Ref: L3-4						
2	180 11-10-2012	FERRITE BEAD 600R@100MHZ 300mA 0805 SM	0 EA	.0	A	Y	N	6.000000
		Ref: L1-2,L6,L8-10						
2	190 12-02-1087	IC REG +5.0V TO-220 TH LM1086	0 EA	.0	A	Y	N	1.000000
		Ref: U19						
2	200 12-64-8832	IC ADC 2-CH 10-BIT W/MULTIPLEXER SM ADC08832	0 EA	.0	A	Y	N	1.000000
		Ref: U20						
2	210 15-62-0000	IC 74HC00 CMOS QUAD NAND SO-14 SM	0 EA	.0	A	Y	N	1.000000
		Ref: U3						
2	220 15-62-0273	IC 74HC273 FLIP-FLOP D-TYPE 8-BIT SO-20 SM	0 EA	.0	A	Y	N	1.000000
		Ref: U16						
2	230 15-64-0541	IC 74HCT 541 OCTAL BUF/DRIVER 3-S 8 SM	0 EA	.0	A	Y	N	1.000000
		Ref: U6						
2	240 15-67-0179	IC RS-485 LOW PWR DIFF TRANSCIEVER SN75LBC179 SO-8 SM	0 EA	.0	A	Y	N	1.000000
		Ref: U9						
2	250 15-78-1024	IC EEPROM 1K 64X16 SERIAL AK93C45 SOP-8 SM	0 EA	.0	A	Y	N	1.000000
		Ref: U1						
2	260 15-92-5810	IC RESET 5V 5% ACTIVE-HI SOT-23 SM LM810	0 EA	.0	A	Y	N	1.000000
		Ref: U4						
2	270 18-20-0002	LED RED SUPER SML-LX0805SRC-TR 0805 SM	0 EA	.0	A	Y	N	1.000000
		Ref: D15						
2	280 18-24-0003	LED GREEN SUPER SML-LX0805SGC-TR 0805 SM	0 EA	.0	A	Y	N	1.000000
		Ref: D19						
2	290 18-27-0083	LED INFRA-RED, 880nm CLEAR LENS LT5K83-AA-880	0 EA	.0	A	Y	N	1.000000
		Ref: D36						

LINE 6
FBV Shortboard Parts List

2	300 21-00-6616	JACK 1/4" TRS 6-PIN PCB MT HORIZ TH	0 EA	.0	A Y N	1.000000
		Ref: J4				
2	310 21-16-0045	JACK RJ-45 8-PIN FEMALE PCB-MNT RT-ANG	0 EA	.0	A Y N	1.000000
		Ref: J1				
2	320 21-20-1020	HDR PCB MT DIL 20 PIN 2x10x .100 MALE SHRD RT ANG	0 EA	.0	A Y N	1.000000
		Ref: H2				
2	330 21-20-2020	HDR PCB MT DIL 20 PIN 2x10x2mm MALE VERT MT TH	0 EA	.0	A Y N	1.000000
		Ref: H1				
2	340 21-44-0044	SOCKET 44 PIN PLCC - .050 LOW PROFILE SMT	0 EA	.0	A Y N	1.000000
		Ref: u2				
2	350 30-00-0607	SCR 6-32 x 7/16 PHIL PN HD STL w/LK WASH ZINC	0 EA	.0	A Y N	1.000000
		Ref: u19				
2	360 30-12-2210	STDF HEX .250 6-32 F/F .500 LG AL	0 EA	.0	A Y N	1.000000
		Ref: u19				
2	370 30-15-0007	INSULATOR XTAL 4.9mm C-C 11.8x5.6mm MYLAR	0 EA	.0	A Y N	1.000000
		Ref: y1				
2	380 30-18-3030	CLIP GND PCB .30x.30x.07	0 EA	.0	A Y N	1.000000
		Ref: GF1				
2	400 45-01-0004	IC PROGRAMMED MPU FBC v1.00 c/s=26BDh FBC	0 EA	.0	A Y N	1.000000
		Ref: U2				
3	10 15-84-8751	IC MCU 87C51 OTP w/512 byte SRAM 8K ROM PLCC44 BLANK	10 EA	.0	A Y N	1.000000
1	360 50-00-0143	PCBA SWITCH LOWER FBV Shortboard	10 EA	.0	A Y N	1.000000
2	10 06-00-4148	DIODE SMALL-SIGNAL 100V 300mA 4ns DO-35 TH 1N4148	10 EA	.0	A Y N	1.000000
		Ref: D6				
2	20 18-02-0002	LED RED HI INTENSITY L34LSRD	10 EA	.0	A Y N	5.000000
		Ref: D1-5				

LINE 6
FBV Shortboard Parts List

2	30 21-20-1020	HDR PCB MT DIL 20 PIN 2x10x .100 MALE SHRD RT ANG	10 EA	.0	A	Y	N	1.000000
		Ref: H1						
2	40 24-00-0001	SWITCH MOMENTARY PUSH BUTTON DPDT 5x8mm 6P DIL TH PCB	10 EA	.0	A	Y	N	5.000000
		Ref: SW6-10						
1	370 50-00-0144	PCBA SWITCH MIDDLE FBC	10 EA	.0	A	Y	N	1.000000
2	10 06-00-4148	DIODE SMALL-SIGNAL 100V 300mA 4nS DO-35 TH 1N4148	10 EA	.0	A	Y	N	1.000000
		Ref: D11						
2	20 18-02-0002	LED RED HI INTENSITY L34LSRD	10 EA	.0	A	Y	N	4.000000
		Ref: D7-10						
2	30 21-20-1020	HDR PCB MT DIL 20 PIN 2x10x .100 MALE SHRD RT ANG	10 EA	.0	A	Y	N	1.000000
		Ref: H2						
2	40 24-00-0001	SWITCH MOMENTARY PUSH BUTTON DPDT 5x8mm 6P DIL TH PCB	10 EA	.0	A	Y	N	5.000000
		Ref: SW1-5						
1	380 50-00-0145	PCBA SWITCH UPPER	10 EA	.0	A	Y	N	1.000000
2	10 06-00-4148	DIODE SMALL-SIGNAL 100V 300mA 4nS DO-35 TH 1N4148	10 EA	.0	A	Y	N	1.000000
		Ref: D13						
2	20 18-02-0002	LED RED HI INTENSITY L34LSRD	10 EA	.0	A	Y	N	1.000000
		Ref: D12						
2	30 21-20-1020	HDR PCB MT DIL 20 PIN 2x10x .100 MALE SHRD RT ANG	10 EA	.0	A	Y	N	1.000000
		Ref: H3						
2	40 24-00-0001	SWITCH MOMENTARY PUSH BUTTON DPDT 5x8mm 6P DIL TH PCB	10 EA	.0	A	Y	N	2.000000
		Ref: SW1-2						
1	390 50-00-0199	ASSY CHASSIS TOP w/ARTWORK FBV Shortboard						1.000000



FBV SHORTBOARD TEST INSTRUCTIONS

The FBV SHORTBOARD is mostly a self-testing device that will simply require power to be applied to test the unit. You will need to connect the FBV SHORTBOARD to a Line 6 host amplifier (ie. POD XT, Vetta, or DuoVerb) via an RJ-45 cable. The following instructions detail the test process and the very important pedal calibration process.

***Please note: The FBV Shortboard can not be used with nor powered by AX2, Flextone 1, Flextone 2, Spider, POD, POD 2.0, POD Pro, Bass POD or Bass POD Pro products.**

AUTOMATED TEST PROCEDURE

1. First, check the **FIRMWARE VERSION**: Press **BANK DOWN+MODULATION+REVERB**. The display should read “ **FBV V1_00** ” or higher. If this is not displayed install a new MPU chip programmed with the current firmware code release.
2. **START TEST MODE**: To activate the test mode, press the **BANK DOWN+STOMP+REVERB** foot switches at the same time and release. (See Diagram 3). A sequence of automated tests will commence in the following order:
 - A. **LCD TEST**
 - B. **SWITCH/LED TEST**
 - C. **COMM TEST** (see detailed instructions for these tests below).

<Note: The pedals will be tested and calibrated in the sections following the automated test procedure>

Diagram 3.



A. **LCD TEST**: This test will start by turning on all segments of the LCD for about 10 seconds. Then all segments will then turn off. The first three characters are seven-segment characters. The fourth character is a fourteen-segment character. The special flat symbol is located to the right of the fourth character. The remaining sixteen characters are fourteen-segment characters. The operator should note if any segments of the LCD are not working properly (which the operator should do quickly and accurately due to the 10 sec.) and have the faulty LCD module replaced.

B. **SWITCH/LED TEST**: This test starts with **ALL LED'S TURNED ON** so that the operator notes if any LED's are not working properly and should have the faulty LED's replaced. Also, they show which switches to still test. The operator will press and release all foot switches one at a time. The LCD will display the name of the footswitch that is being depressed and the corresponding LED should turn off. The operator **must** make sure the name matches the name of the switch when depressed.

***NOTE:** For this step, make sure that each of the 12 momentary switches produces a consistent “click” when depressed. If not, replace the faulty switch.

Test the pedal toe switch under the pedal by placing the palm of your hand at the top of the pedal and your fingers around and behind the FBV top chassis. (See Diagram 4). Press on the pedal with your hand until the footswitch clicks. Use caution so you do not bend or warp the metal when you press down. (Note: The LED's to the side of the pedal will not turn off at this time but the LCD will display the pedal switch name when the pedal toe switch is pressed). This test will remain active until the operator moves on to the next step **COMM TEST**. The operator should note if any footswitches are not working properly and have the faulty footswitches replaced. Also, the operator should have any footswitches replaced that do not produce a tactile click when fully depressed.

Diagram 4.



To Exit the Footswitch portion of the automatic test press **BANK DOWN+DELAY+REVERB**. This will automatically start the **COMM TEST** (see below).

D. COMMUNICATIONS TEST: This test will automatically determine the ability of the FBV to send and receive data from a host (e.g. Vetta Combo). If the test passes the LCD will display “**COMM TEST PASSED**” followed by “**TEST PEDALS**”. If the test fails, the LCD will display “**COMM TEST FAILED**”. You will need to press **BANK DOWN+DELAY+REVERB** to exit the error message. If the test fails then you should first check the RJ45 cable on the test fixture and make sure it is connected properly to the FBV (you will know this automatically if the backlight is not turned on but the LCD is working). If the cable is connected properly then replace the main PCB in the FBV.

PEDAL TESTING

To test the foot pedals; you must press a special footswitch combination as follows:

LEFT INTERNAL PEDAL: STOMP+DELAY+REVERB

RIGHT EXTERNAL PEDAL: BANK DOWN+STOMP+DELAY

<Note: You can only test one pedal at a time>

The LCD will display one letter and four sets of numbers. “**L 000 111 222 333**” for **LEFT INTERNAL PEDAL TEST** and “**R 000 111 222 333**” for the **RIGHT EXTERNAL PEDAL TEST**. (See Diagram 5).

Diagram 5.

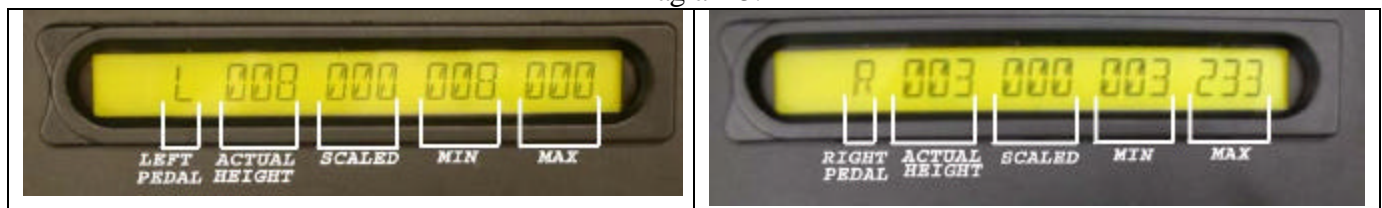

L = Left Pedal (Internal Pedal)

R = Right Pedal (External Pedal)

000 = Actual pedal height, (range is 000...255) with 0 being at the heel down position and 255 being at the toe down position. Note that in actual usage, the min and max numbers will be something in between 0 and 255.

111 = Scaled normalized pedal number using the max and min values to output a number between 0 and 127.

222 = the pedal min value (0...255) this is a stored version of the pedal's lowest heel down (MIN) position.

333 = the pedal max value (0...255) this is a stored version of the pedal's highest toe down (MAX) position.

To test out the pedals, you are only concerned with the **MAX** and **MIN** values. Swing the pedal under test from its **MAX** position to its **MIN** position. You may watch the ACTUAL PEDAL HEIGHT number (000) to verify its position. The values should be within the ranges as shown below:

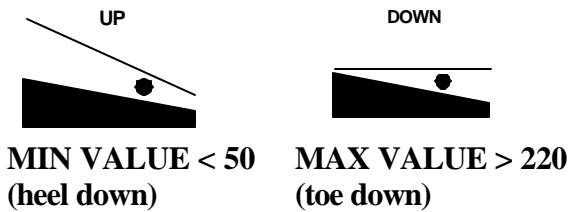

If the pedal has passed the above test within the correct values, slowly press the pedal down to its heel position and then press down on the heel slightly. The second column (111) value should go down to 000. If the 111 column value goes up while the pedal is going down to the heel position, fail it. It will require pedal lance adjustment.

If any of the pedals are not within the specified the following may be checked in this order:

- a) The pedal's lance is not at the correct angle. When the pedal lance is at its correct angle the tip of the lance should be parallel to the PCB when the pedal is all the way in its heel down position. See the engineering released pedal drawing Line 6 #30-51-0085 Rev E (or higher if applicable). Check also that when the pedal lance is closest to the board it is within the specified distance to the board (See FBV SHORTBOARD assembly instructions).
- b) The copper tape on the lance is properly applied.
- c) The pedal sensor's infrared LED or Phototransistor may be out of spec. You can try replacing both of these parts at the same time (IR LED=Line 6 #18-27-0083, Phototransistor = 09-20-0095). LEFT PEDAL: IR LED = D36, Phototransistor = Q42.

To exit the LEFT or RIGHT pedal test move on to **PEDAL CALIBRATION** on the next page.

PEDAL CALIBRATION

Once the FBV has passed all of the above tests, you must calibrate the pedals. Every time an FBV is opened and then closed, you must recalibrate the pedals.

1. Start by attaching the chassis base with **all 10 screws** (some screws have rubber feet). **IT IS VERY IMPORTANT THAT THE BASE BE ATTACHED FOR THIS.**
2. Connect the FBV SHORTBOARD to the host amplifier (POD XT, Vetta or DuoVerb.)
3. Move both pedals to their center positions roughly halfway between the MAX and MIN position.
4. Press BANK DOWN+MODULATION+DELAY and hold for three seconds. This will reset the calibration values for the pedals to their default values.
5. Press STOMP+DELAY+REVERB and hold for three seconds. This will now display the pedal information for the LEFT INTERNAL PEDAL.
6. Move the pedal to its MIN position and press down (pedal all the way heel down).
7. Move the pedal to its MAX position (pedal all the way toe down) and press down hard enough to actuate the pedal's toe switch.
8. Check the range on the MAX (number displayed on right hand side of display) and MIN (number displayed second from right hand side of display) values to see that they are within spec (Pedal Testing section above).
9. Move the pedal to its MIN position. With the pedal just sitting there, check the number displayed in the second column (111). It should read 000. Press the pedal down at the heel position. This number should still read 000. If this number is nonzero for either of these two cases then check the items listed for troubleshooting under "Pedal Testing" above.
10. Press BANK DOWN+STOMP+DELAY and hold for three seconds. This will now display the pedal information for the RIGHT EXTERNAL PEDAL.
11. Repeat steps 6 through 9 only for the RIGHT EXTERNAL PEDAL.
12. You just calibrated the pedals. Remove the RJ45 cable to power down the unit.

FBV Shortboard Mechanical Assembly Instructions

REV B

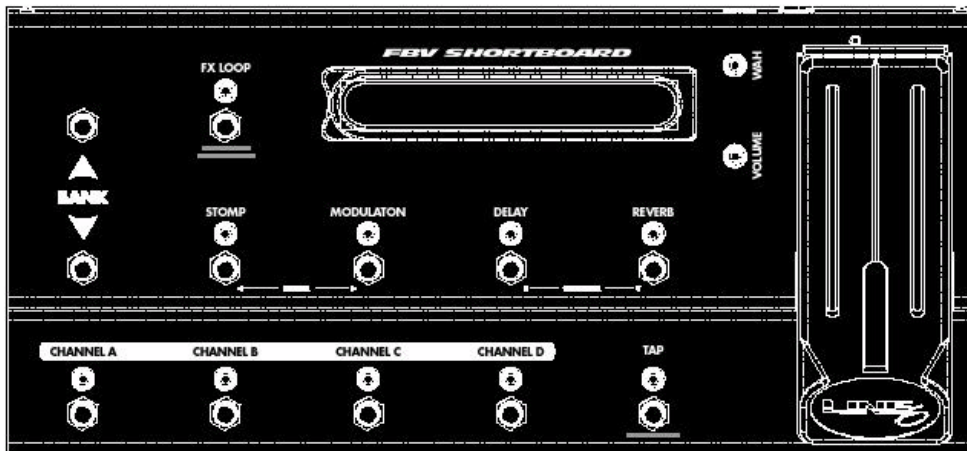

Forward and Notes

The information in this booklet applies to the FBV Shortboard . It is suggested that the steps for assembly follow the order presented in these instructions.

This booklet deals with the assembling of the major sub-assemblies, the final product, and quality/inspection considerations. See also the Related Electrical assembly documentation for major considerations in assembling the electrical components of the PCBs (through the soldering process and preparation of the board for addition of custom components.

A note on the text: the illustrations in this book are for reference only. In some cases, color and geometry of illustrations may not accurately reflect the color or exact geometry of actual parts.

- Unless otherwise noted, all dimensions are in inches.
- Part identifying notes are in this format: Description (Part Number)
- Drawings are not to scale.
- Torque value tolerance +/- .5 in.-lbs. Do not over tighten any components.
- For clarity, not all component details are shown. This is especially true with respect to cable assemblies. They are often omitted from views to provide a clearer picture of the material discussed. Do not be confused by the absence (or unexpected presence) of any component in the illustrations in this book.

Table of Contents

- Light Pipe Assembly 2
 - 1 Light Pipe P/N 30-27-0038..... 3
- Pedal Switch PCB Assembly..... 3
- Pedal Switch PCB to Chassis Assembly..... 5
- Pedal Sub-Assembly..... 7
- Pedal Assembly 9
 - SAE Steel Washers..... 9
 - Nylon Spacers..... 9
- Stomp Switch PCBs to Chassis Assembly 10
- Display to Chassis Assembly 12
- Display Cable Attachment and Pedal Lance Adjustment 13
- Corrugated Support Attachment 14
- Final Assembly..... 16

Light Pipe Assembly

The FBC requires 12 Light Pipe assemblies. Each assembly consists of the following;

1 Light Pipe. Line 6 P/N 30-27-0038

1 Finishing Washer. Line 6 P/N 30-03-0014

1 Push Retainer. Line 6 P/N 30-06-0008

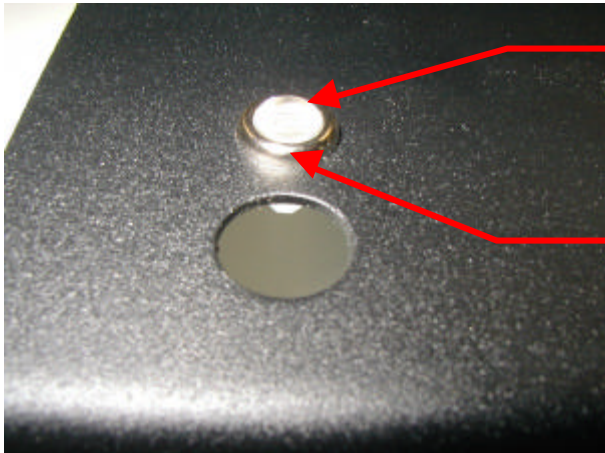

Light Pipe. Line 6 P/N 30-27-0038. 12 required

Finishing Washer. Line 6 P/N 30-03-0014. 12 required

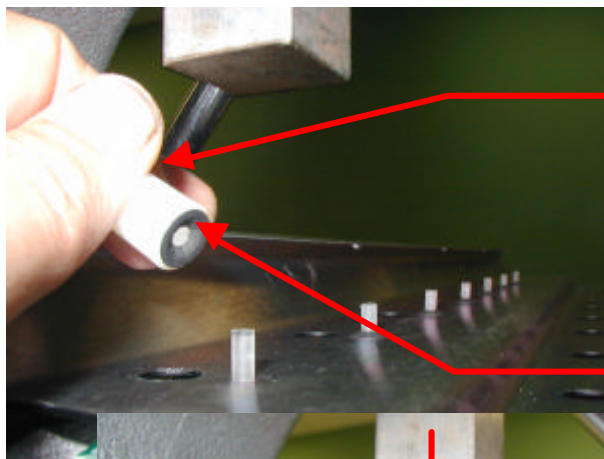

Plastic Bushing used for assembly

Push Retainer. Line 6 P/N 30-06-0008. 12 required

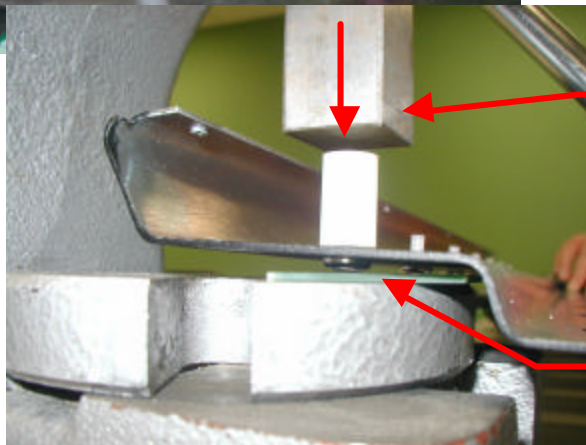

Arbor press shown here is used to press the Push Retainer on to the Light Pipe. A simple fixture is all that is required.

The Light Pipe should rest on a surface that will not scratch it.

Pedal Switch PCB Assembly

There is one (1) Pedal Switch PCB assembly required per FBC. To complete this sub-assembly place three (3) Tactile Domes aligned on top of each other (make sure there are exactly 3 Tactile Domes used, they are thin and easily miss-counted) and tape them to the Pedal Switch PCB so that the feet of the bottom Tactile Dome rest on the conductive pads.

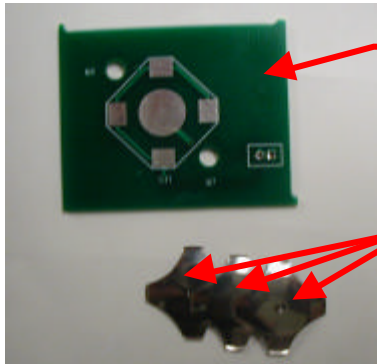

Pedal Switch PCB 1 required per Sub-assembly. Line 6 P/N 35-00-0116.

Tactile Domes. Line 6 P/N 30-51-0078. 3 required per Sub-assembly.

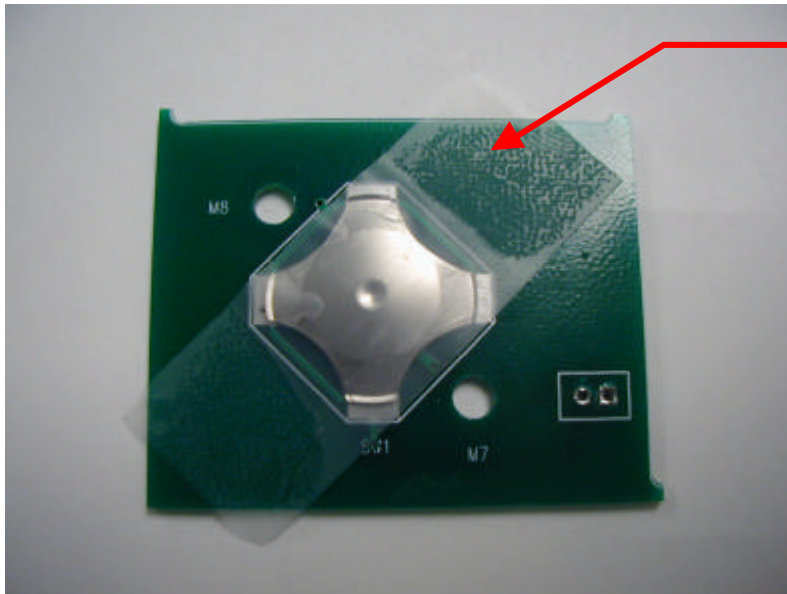

Clear tape used to hold Tactile Domes in place for assembly. Please notice the alignment of Tactile Domes and placement of tape. (Tape should be equivalent to Scotch Transparent Tape 144)

Pedal Switch PCB to Chassis Assembly

The assembly of the Pedal Switch PCB sub-assembly to the Chassis is completed using the following:

2 Nylon Washers. .5 x .170 x .04 thick. Line 6 P/N 30-03-0013.

2 Round Aluminum Spacers. 1/4 O.D. x .166 I.D. x .460 LNG. Line 6 P/N 30-15-0005.

1 Round Plastic Insulator. .17 O.D. x .156 I.D. x .460 LNG. Line 6 P/N 30-15-0006.

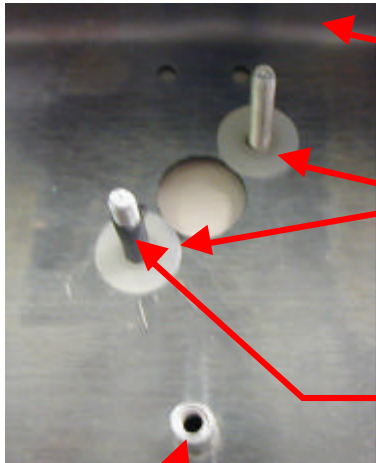

Back surface of the Chassis.

Nylon Washers. Line 6 P/N 30-03-0013.

Round Plastic Insulator. Line 6 P/N 30-15-0006.

PEM for
Main PCB

IMPORTANT: Note the location of the insulator. The pedal activation will not work if the insulator is not on the correct stud.

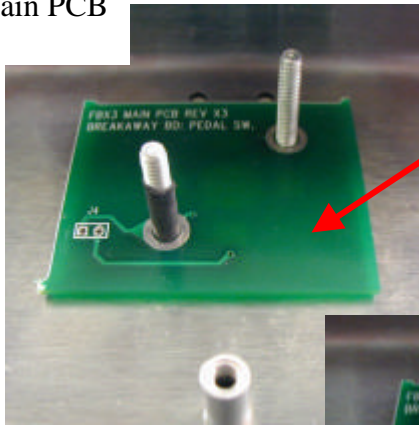

Pedal Switch PCB sub-assembly.

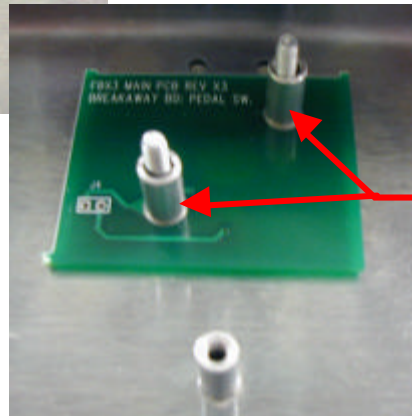

Round AL Spacers. Line 6 P/N 30-15-0005.

Main PCB to Chassis Assembly

The assembly of the Main PCBA to the chassis is completed using the following:

- 1, Main PCBA. Line 6 P/N 50-00-0142
- 2, 6-32 x .375 screws with captive star washers. Line 6 P/N 30-00-1633.
- 2, 6-32 Hex nuts with captive star washers. Line 6 P/N 30-06-0623

First, secure the ¼" jack (part of the PCB Assy) to the chassis using the ¼" jack nut.
Then, secure the PCB to the mounting studs using the Hex Nuts and Screws.

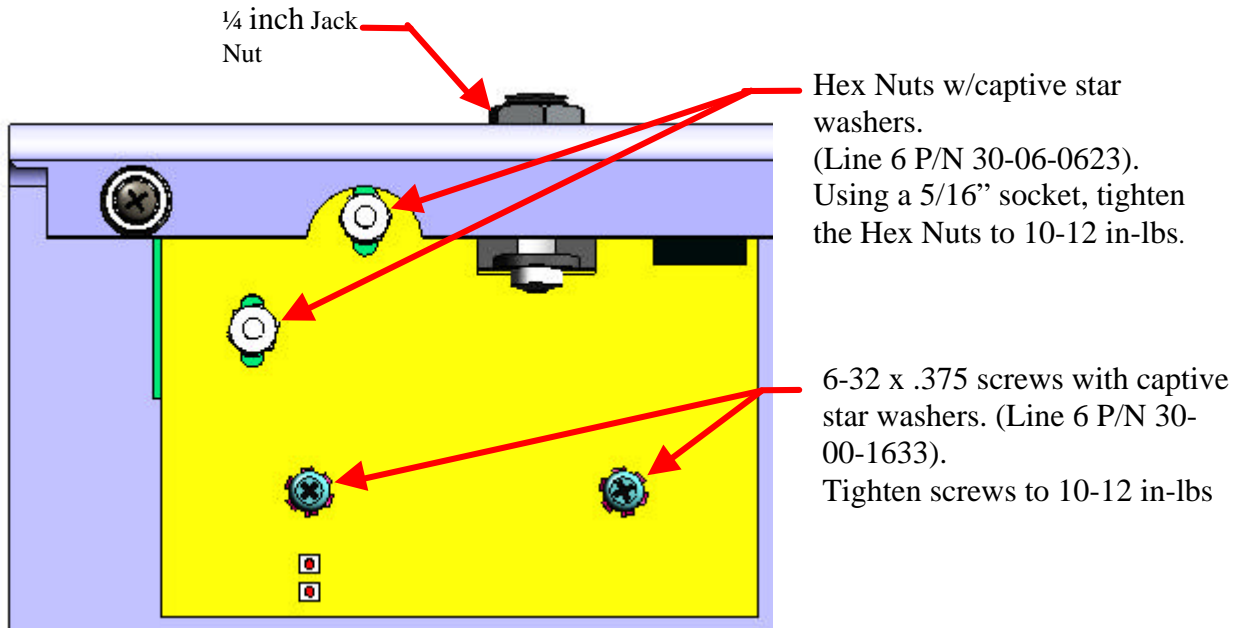

Pedal Bracket to Chassis Assembly

The Pedal Bracket, Line 6 P/N 30-51-0046, is attached to the under side of the chassis using 4, 6-32 x .250 Pan Head Phillips Screws. Line 6 P/N 30-00-0013.

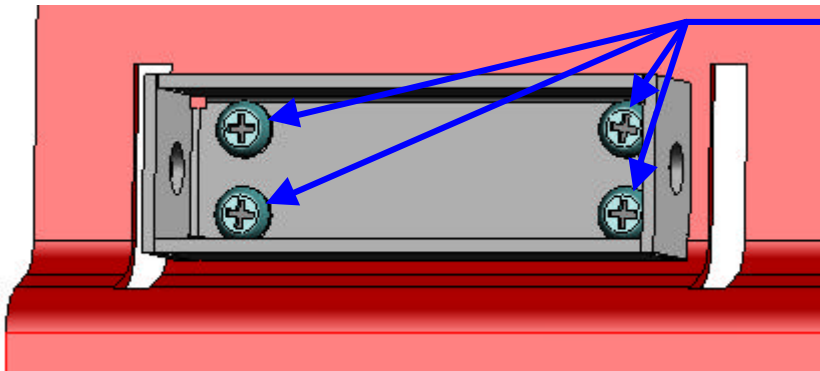

6-32 x .250 Pan Head Phillips Screws. Line 6 P/N 30-00-0013. Torque each screw to 10-12 in-lbs

Pedal Sub-Assembly

To complete the Pedal sub-assembly, the following shall be attached to the Pedal, Line 6 P/N 30-51-0085. Each rubber part has pressure sensitive adhesive on the side to be attached to the Pedal.

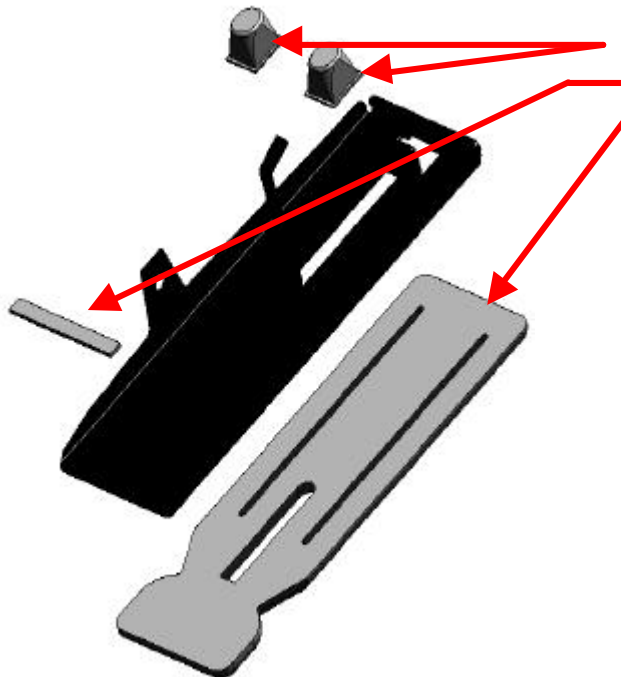

2 Rubber Pedal Stops. Line 6 P/N 30-75-5514 3M).
1 Foam Rubber Pedal Stop. Line 6 P/N 30-75-0007.
1 Rubber Cover. Line 6 P/N 30-75-0002.

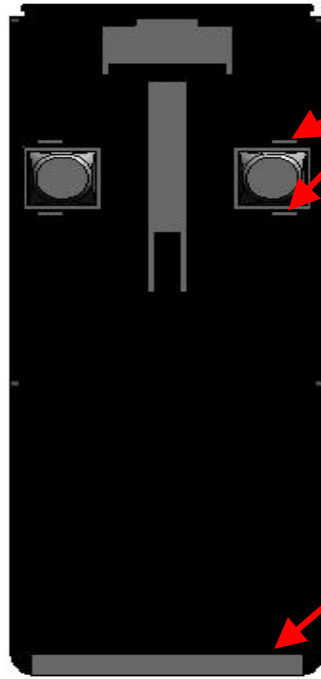

Please notice the placement of the Pedal Stops between the small rectangular cutouts. Also make sure that they are as close to the Pedal edge as possible

The Foam Rubber Stop shall be placed close to the bottom edge of the Pedal as shown

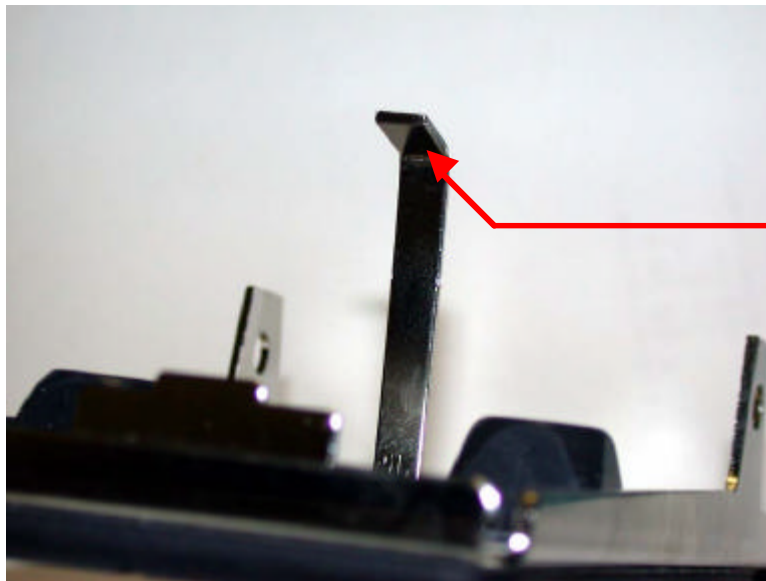

Make sure reflective surface of pedal lance is clean and free of any contaminants. Alcohol may be used to clean if necessary.

Note: If unit cannot be properly calibrated and is not achieving a minimum value of less than 50 during pedal calibration, copper tape should be applied to the pedal lance. Refer to “Pedal Lance Copper Tape Preparation.doc”

Pedal Assembly

The Pedal is attached to the Chassis by using the following parts:

- 4 Steel Washers. $\frac{1}{4}$ ID x $\frac{1}{2}$ OD x .030 thick. Line 6 P/N 30-03-0003.
- 2 Nylon Spacers. $\frac{1}{4}$ ID x $\frac{1}{2}$ OD x .125 thick. Line 6 P/N 30-03-0007.
- 2 Nylon Spacers. $\frac{1}{4}$ ID x $\frac{1}{2}$ OD x .030 thick. Line 6 P/N 30-03-0005.
- 1 $\frac{1}{4}$ -20 Locknut with nylon insert. Line 6 P/N 30-06-0009.
- 1 Socket Head Cap Screw. $\frac{1}{4}$ -20 UNC-2A x 3.50 Lg. Line 6 P/N 30-00-0012.
- 1 Tape. 2.6 mil. 2 inch x .25 inch copper with adhesive. Line 6 P/N 30-65-0003.
- 1 Spacer, .39 inch Dia x 2.40 inch Lg. Line 6 P/N 30-15-0011.

The Spacer, Line 6 P/N 30-15-0011, is added to prevent the Pedal Bracket from “collapsing” when the torque is applied to the socket head cap screw.

Pedal Assembly (continued)

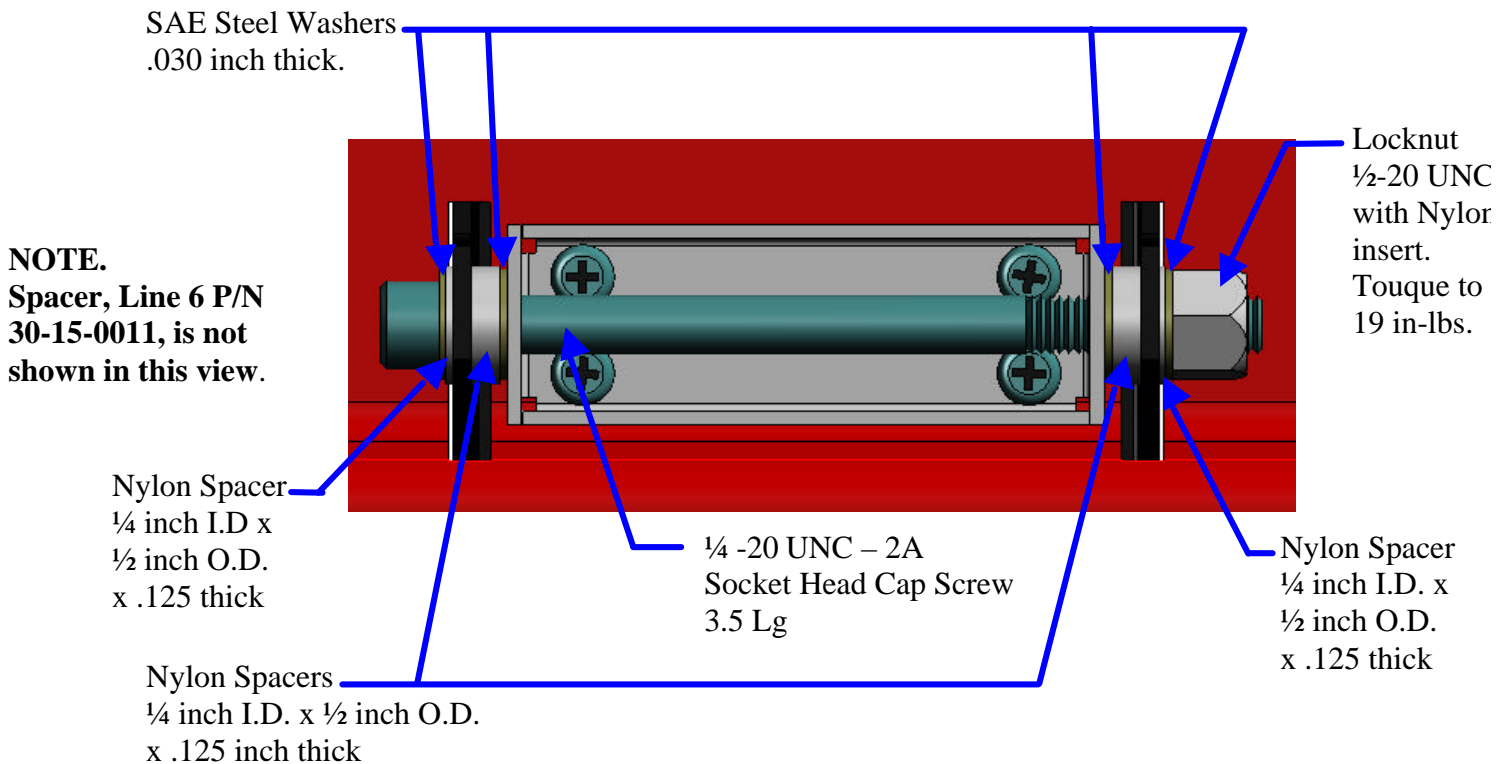

NOTE.
Spacer, Line 6 P/N
30-15-0011, is not
shown in this view

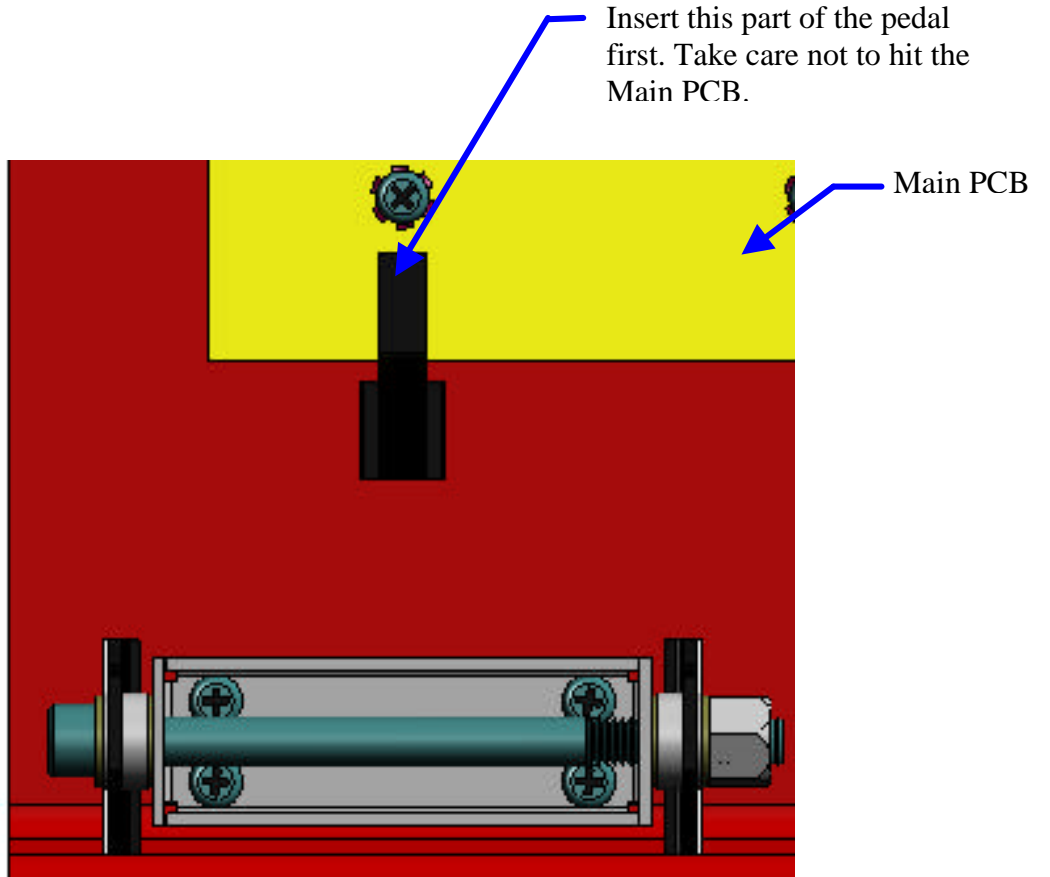

Stomp Switch PCBs to Chassis Assembly

There are three (3) stomp switch PCB Assemblies. They are Top, Middle and Bottom. Each assembly is held to the chassis by the stomp switches.

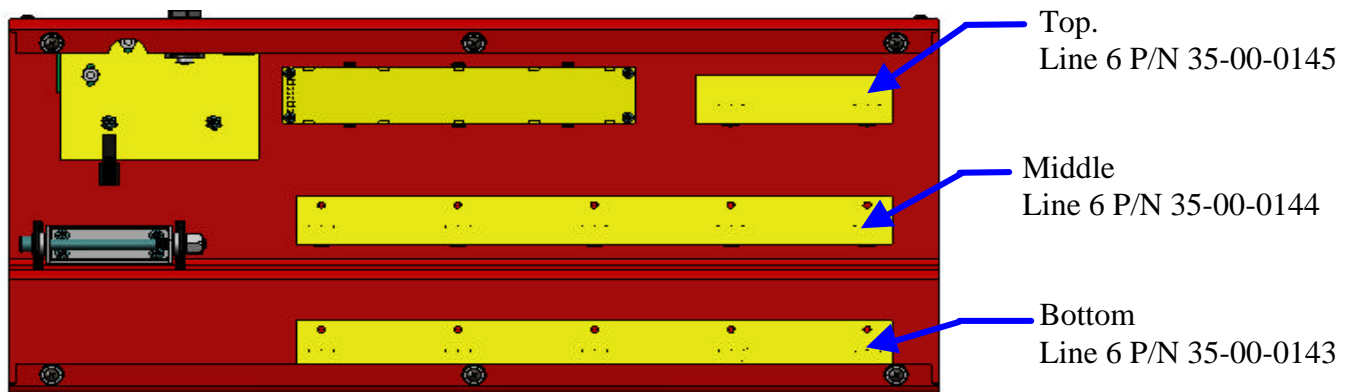

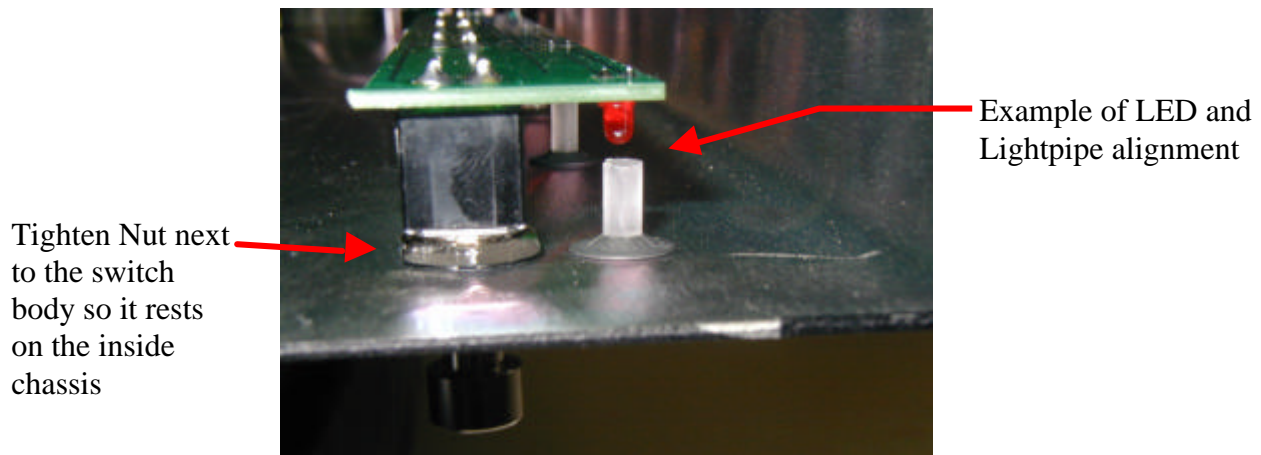
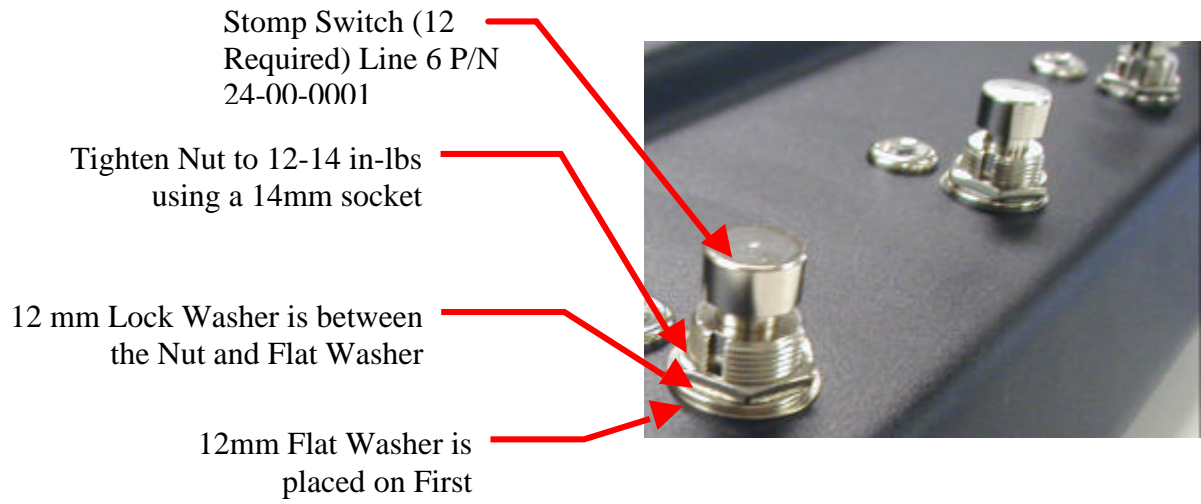

Display to Chassis Assembly

To complete the Display Assembly and attach it to the Chassis, use the following:

1 Bezel. Line 6 P/N 30-27-0030.

1 Lens. Line 6 P/N 30-27-0037.

1 LCD Module. Line 6 P/N 50-00-0092.

4 4-24 Type B x .500 thread forming screws. Line 6 P/N 30-00-0016.

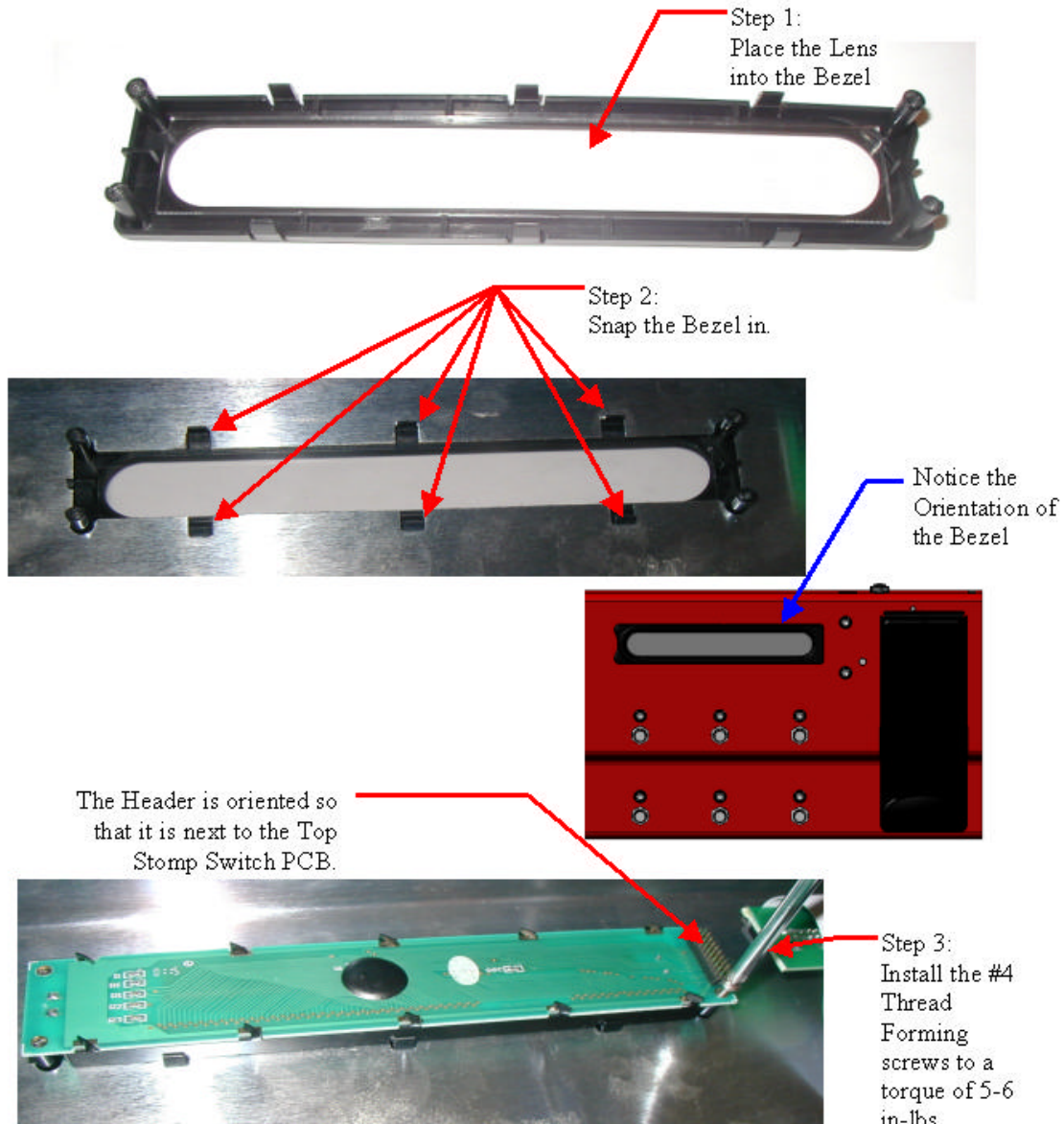

Display Cable Attachment and Pedal Lance Adjustment

The Display Cable, Line 6 P/N 21-30-0024, is attached to the Main PCB as shown below. Apply RTV adhesive to the cable header areas to prevent the cable from coming loose during shipping etc.

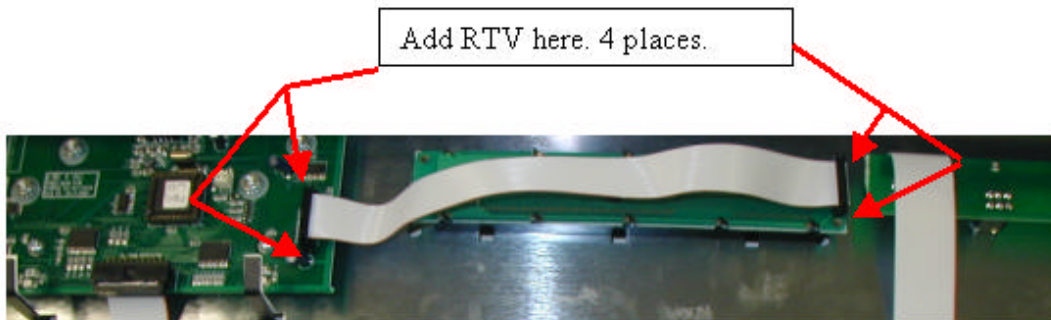

Pedal Lance adjustment:

The optimum set up for the angle of the lance is such that the lance reflective surface is parallel to the PCB when the pedal is at the full heel position:

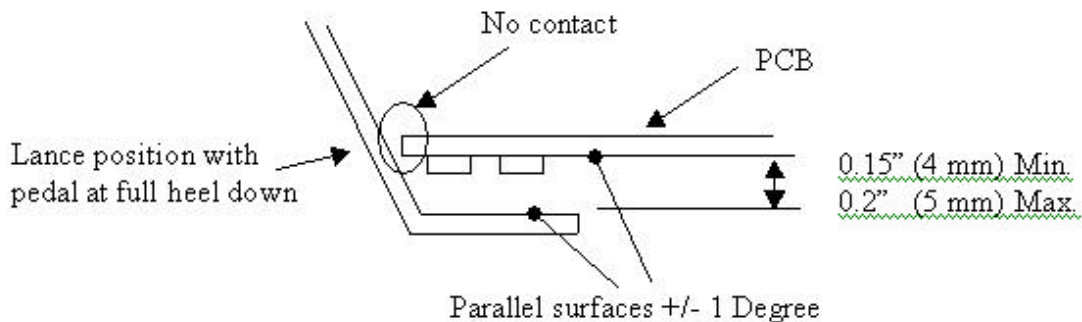

Toe switch activation force:

With the following components:

- 3M rubber bumpers (3M part number SJ5514) positioned between the two registration notches.
- 3 stacked Snaptron domes per pedal. (Snaptron part number FD202250, specified at trip force 2250g each).

The activation force, measured on the pedal right above the activation strike, should be between 50 to 75 Pounds (22.7 Kg to 34.0 Kg).

Corrugated Support Attachment

The Corrugated Support, Line 6 P/N 30-51-0077, is attached to the Chassis, Base, Line 6 P/N 30-51-0106 mounting holes, using two (2) No.6-32 x .375 Lg Phillips pan head screws, Line 6 P/N 30-00-1632, and two (2) bumpers with steel washers inside, Line 6 P/N 30-48-5012. Important: Note the orientation of the Support. Damage may result if the support is not placed on the base correctly.

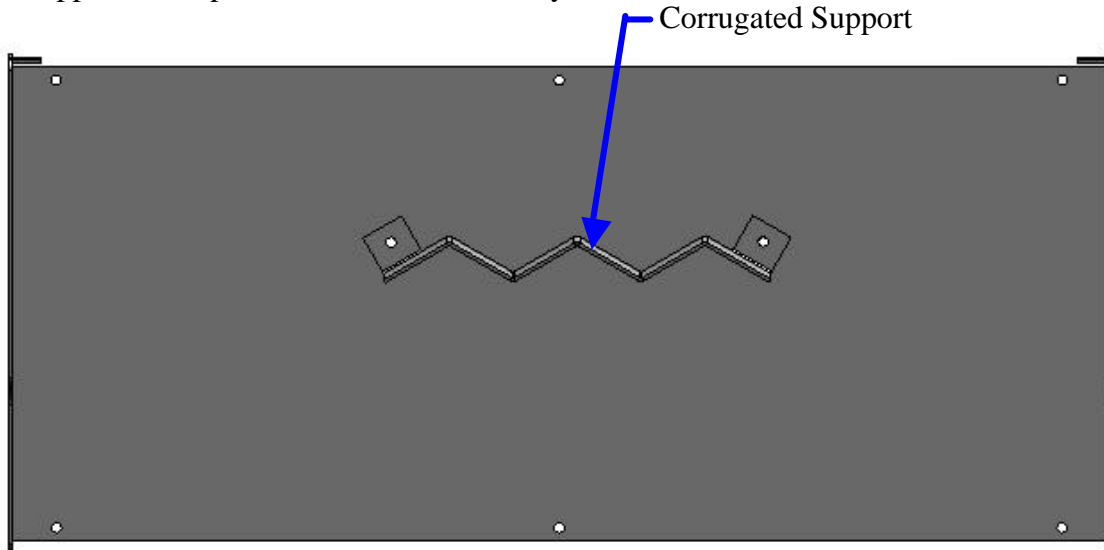

Foam Strip Attachment

Position Foam Strip, Line 6 P/N 30-63-0002, onto inside surface of Chassis, Top, Line 6 P/N 30-51-0104, as shown.

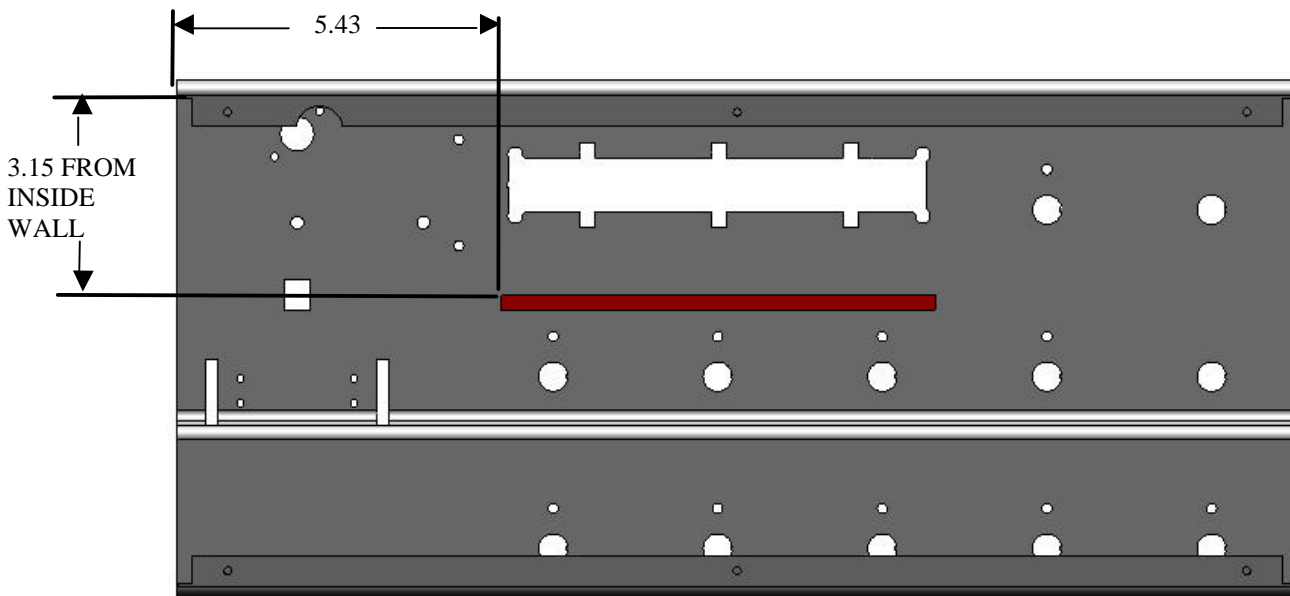

Stomp Switch Cable Attachment

Attach the Stomp Switch PCB Assemblies to the Middle PCB via the Cable, Line 6 P/N 21-34-0023. Apply tape as shown to secure cable assemblies to chassis.

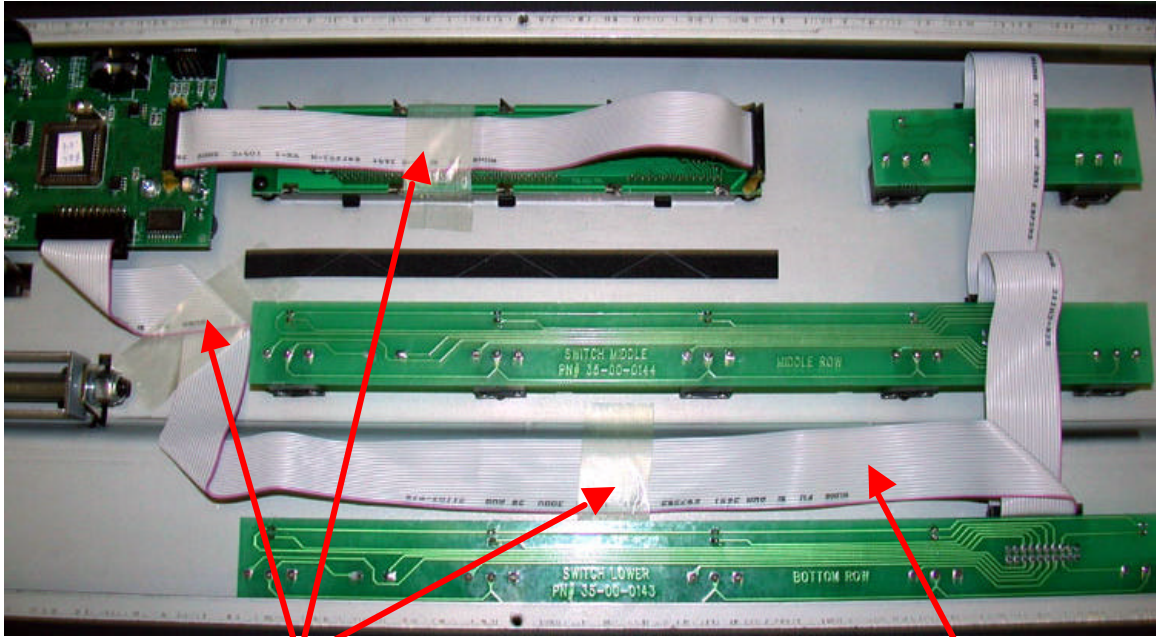

Tape applied to secure cable assembly

Cable P/N 21-34-0023

Final Assembly

To complete the assembly of the Chassis to the Base requires the following

6 No. 6-32 x .375 Phillips pan head screws. Line 6 P/N 30-00-1632.

6 No. 6 Bumpers with steel washers inside. Line 6 P/N 30-48-5012.

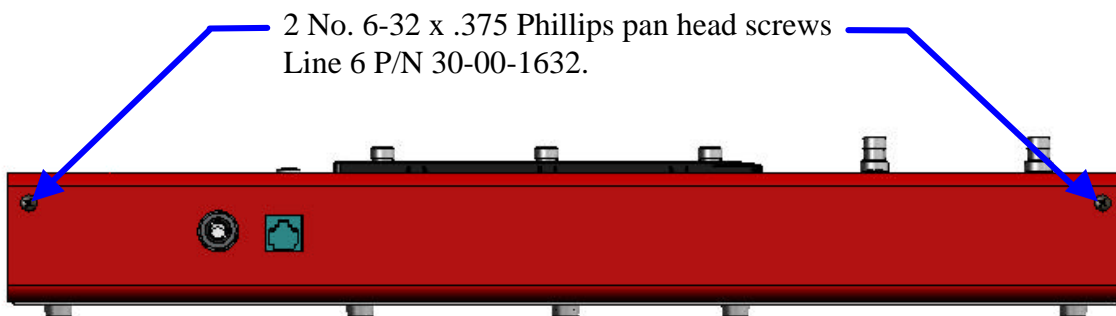
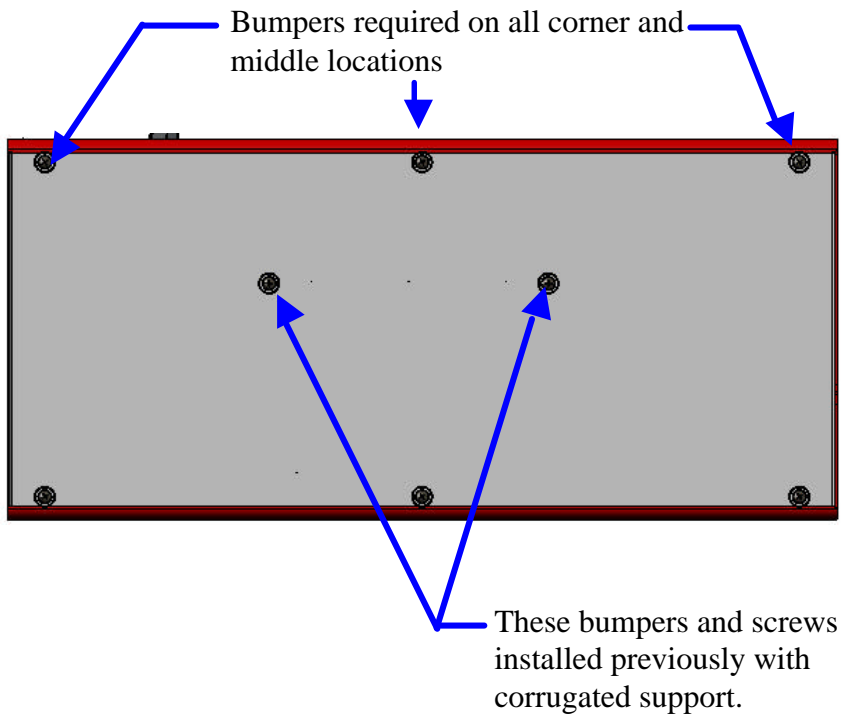



SERIES FOOT CONTROLLERS

Care and Feeding

When moving your FBV around, always grab it by the edges of the main body's metalwork; do not lift up the FBV by the pedals. You can clean the FBV with a damp (not wet) cloth. If you own a Vetta combo, you will find that the FBV is sized to fit into the back of the amp; insert the pedal so its display and switches face the magnets, with the thin edge of the pedal (the edge that would normally be toward you as you stand in front of the pedal while using it) toward the bottom of the amp.

Getting Connected

The FBV series foot controllers are designed exclusively for Line 6 products. Check your product manual to ensure it is compatible with FBV. Your FBV connects with the included locking cable. This cable allows communication, and also supplies the FBV with power; there is no separate power cord needed for the FBV.

Calibrating Your Foot Pedals

Calibration matches the FBV software to the exact physical range of the pedal controls:

1. Make sure your FBV is connected to your Line 6 product and that it is powered up.
2. Press the **AMP 1**, **AMP 2**, and **TREMOLO** switches simultaneously and hold down for about 3 seconds. **For the FBV Shortboard** press **BANK DOWN**, **MODULATION** and **DELAY** switches and hold for about 3 seconds. There will be no indication that you have entered a special mode — pedal calibration is “invisible”.
3. With your foot on the Left pedal, press forward all the way until the pedal's toe switch clicks.
4. Now pedal back toward the heel and apply pressure when you reach the heel position.
5. Repeat steps 3 and 4 for the Right pedal. This procedure only works for the internal pedal on the FBV Shortboard. The FBV Shortboard will automatically adjust itself to variations in expression pedals connected to the rear panel 1/4-inch jack.
6. Your pedals are now calibrated.



Cable Specifications

The cable that connects the FBV is a standard cable used in the computer industry for connecting networks of computers. We chose this type of cable for the FBV because (1) it can carry multiple signals simultaneously, allowing it to transport both power and communications between FBV compatible products and the FBV, eliminating the need for multiple tangled cables or a bulky wall wart; (2) it gives you locking connectors on both ends to insure you don't disconnect from your product or FBV by accident when you're jumping up and down on your FBV; (3) it has a proven track record for reliability in millions of computer installations around the world; (4) replacement cables are available in a variety of lengths and at low cost at any major computer supply store.

When purchasing a replacement cable, you should specify a:

“Category 5, 10 Base-T or RJ-45 cable with male connectors on both ends.”

There is a 1 to 5 grading system for computer network cable quality, with 5 being the highest quality. Get the good one.

The connectors on the end of the cable are called RJ-45 connectors; these are the standard type of connector used for 10 Base-T computer networks. So asking for “a 10 Base-T cable” or for “an RJ-45 cable” should get you what you need.

If you're unsure if you've got the right thing, note that the RJ-45 connectors basically look like a wide version of standard US telephone line connectors, with eight contacts instead of four.