

MACKIE.®

HUI

Human User Interface
for Digital Audio Workstations

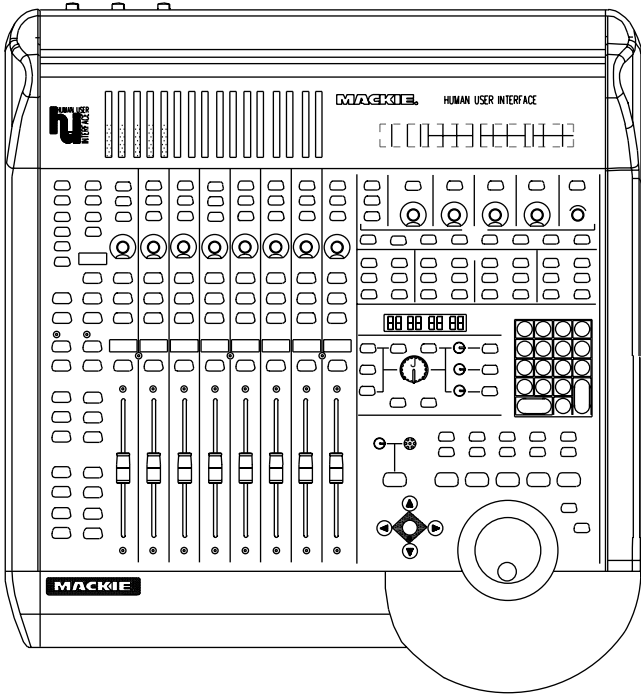

SERVICE MANUAL

	CAUTION AVIS RISK OF ELECTRIC SHOCK DO NOT OPEN <i>RISQUE DE CHOC ELECTRIQUE NE PAS OUVRIR</i>	
---	--	---

CAUTION: TO REDUCE THE RISK OF ELECTRIC SHOCK DO NOT REMOVE THE COVER (OR BACK) NO USER SERVICEABLE PARTS INSIDE REFER SERVICING TO QUALIFIED PERSONNEL

WARNING: TO REDUCE THE RISK OF FIRE OR ELECTRIC SHOCK, DO NOT EXPOSE THIS PRODUCT TO RAIN OR MOISTURE

TO PREVENT ELECTRIC SHOCK, DO NOT USE THIS POLARIZED PLUG WITH AN EXTENSION CORD, RECEPTACLE OR OTHER OUTLET UNLESS THE BLADES CAN BE FULLY INSERTED TO PREVENT BLADE EXPOSURE.

ATTENTION: POUR EVITER LES RISQUES DE CHOC ELECTRIQUE, NE PAS ENLEVER LE COUVERCLE. AUCUN ENTRETIEN DE PIECES INTERIEURES PAR L'USAGER. CONFIER L'ENTRETIEN AU PERSONNEL QUALIFIE.

AVIS: POUR EVITER LES RISQUES D'INCENDIE OU D'ELECTROCUTION, N'EXPOSEZ PAS CET ARTICLE A LA PLUIE OU A L'HUMIDITE.

POUR PREVENIR LES CHOCS ELECTRIQUES NE PAS UTILISER CETTE FICHE POLARISEE AVEC UN PROLONGATEUR, UN PRISE DE COURANT OU UNE AUTRE SORTIE DE COURANT, SAUF SI LES LAMES PEUVENT ETRE INSEREES A FOND SANS LAISSER AUCUNE PARTIE A DECOUVERT.

This apparatus does not exceed the Class A/Class B (whichever is applicable) limits for radio noise emissions from digital apparatus as set out in the radio interference regulations of the Canadian Department of Communications.

ATTENTION :Le présent appareil numérique n'émet pas de bruits radioélectriques dépassant les limites applicables aux appareils numériques de class A/de class B (selon le cas) prescrites dans le règlement sur le brouillage radioélectrique édicté par les ministere des communications du Canada.

This equipment has been tested and found to comply with the limits for a Class A digital device, pursuant to part 15 of the FCC rules. These limits are designed to provide reasonable protection against harmful interference when the equipment is operated in a commercial environment. This equipment generates, uses, and can radiate radio energy and, if not installed properly and used in accordance with the instruction manual, may cause harmful interference to radio communications. Operation of this equipment in a residential area is likely to cause harmful interference in which case the user will be required to correct the interference at his own expense.



The lightning flash with arrowhead symbol within an equilateral triangle is intended to alert the user to the presence of uninsulated "dangerous voltage" within the product's enclosure, that may be of sufficient magnitude to constitute a risk of electric shock to persons.

Le symbole éclair avec point de flèche à l'intérieur d'un triangle équilatéral est utilisé pour avertir l'utilisateur de la présence à l'intérieur du coffret de "voltage dangereux" non isolé d'ampleur suffisante pour constituer un risque d'électrocution.



The exclamation point within an equilateral triangle is intended to alert the user to the presence of important operating and maintenance (servicing) instructions in the literature accompanying the appliance.

Le point d'exclamation à l'intérieur d'un triangle est utilisé pour avertir l'utilisateur de la présence d'instructions importantes pour le fonctionnement et l'entretien (service) dans le livret d'instruction accompagnant l'appareil.

CONTENTS

INTRODUCTION 4
 TECHNICAL SUPPORT 4
 DISCLAIMER 4
 SPECIFICATIONS 5
 BLOCK DIAGRAMS 6-11
 QUICK PARTS 12-18
 INTERNAL TEST MODES 19-26
 PARTS LIST B1-B18
 FOLD-OUT SECTIONS:
 FINAL ASSEMBLY A1-A8
 SCHEMATICS S1-S30
 PRINTED CIRCUIT BOARDS P1-P13

CIRCUIT BOARD	PARTS LIST	SCHEMATICS	PCB
CONTROL SURFACE	PAGE B5-B7	PAGES S2-S8	PAGES P2-P4
FADER	B7	S9-S10	P5
METER	B8	S11-S12	P6
DCA	B9	S13-S17	P7
POWER SUPPLY	B11	S18	P9
BRAIN	B10	S19-S20	P8
ANALOG I/O	B12	S21-S23	P10
SERVO	B13-B14	S24-S28	P11
DIGITAL INPUT	B15	S29	P12
DIGITAL OUTPUT	B16	S30	P13

INTRODUCTION

This manual contains service information for the HUI Human User Interface and it's brothers LUI and DUI. It is essential that you have a copy of the user's manual as this contains the complete operating instructions.

The HUI was designed to work with digital audio workstations (DAWs). It allows the human user to have the correct touch and feel of a true audio mixer, instead of trying to use a mouse and keyboard to control the software.



WARNING
Service on the HUI must only be undertaken by experienced service technicians.



To service the HUI, technicians should be familiar with op-amp based and discrete analog circuitry, digital troubleshooting, and the operation / application of mixing consoles and MIDI systems. Presentation of this manual does not constitute endorsement of qualifications by Mackie Designs.

! SMD !

The HUI makes extensive use of surface mount components. Servicing technicians should have the tools, experience and patience to perform surface mount rework.

! ESD !

The HUI contains components that may be damaged by electrostatic discharge. All standard ESD precautions must be taken when servicing.

TECHNICAL SUPPORT

Mackie Designs Technical Support Department is available 8AM - 5PM PST, Monday - Friday at 1-800-258-6883 (outside US call 011-425-487-4333) Please feel free to call with any questions and speak with a HUI-calibrated technician.

DISCLAIMER

The information contained in this manual is proprietary to Mackie Designs, Inc. The entire manual is protected under copyright and may not be reproduced by any means without express written permission from Mackie Designs, Inc.

SPECIFICATIONS

Audio Specifications

Noise

Signal-to-Noise Ratio	> 92 dB
E.I.N. Microphone preamp 20Hz to 20kHz	-129.5dBm
Total Harmonic Distortion	< 0.005%

Input 1,2,3 Left to Right Channel Crosstalk

@ Unity gain	less than 80dB @ 10 kHz
--------------	-------------------------

Frequency Response

20Hz to 60kHz	+0/-1dB
10Hz to 100kHz	+0/-3dB

Maximum levels

Mic preamp input	22dBu
All other inputs	22dBu
Unbalanced outputs	22dBu
Balanced outputs	28dBu

DIM level

Adjustable	-5dB to -40dB attenuation
------------	---------------------------

Impedance

Mic preamp input	2.4k Ω
All other inputs (other than inserts)	>10k Ω
All balanced outputs	240 Ω
All unbalanced outputs	120 Ω

General Specifications

Power Requirements

All configurations	60 watts
--------------------	----------

Fuse

120VAC	1.25A/250V Slow-Blow
100VAC	1.6A/230V Slow-Blow
230VAC	630mA/250V Slow-Blow

Weight

37 lb. (16.8 kg)

Dimensions

Height	6.5 inches (16.5cm)
Width	20.6 inches (52.3cm)
Depth	
Right Side	22.5 inches (57.2cm)
Left Side	20.75 inches (52.7cm)

BLOCK DIAGRAMS

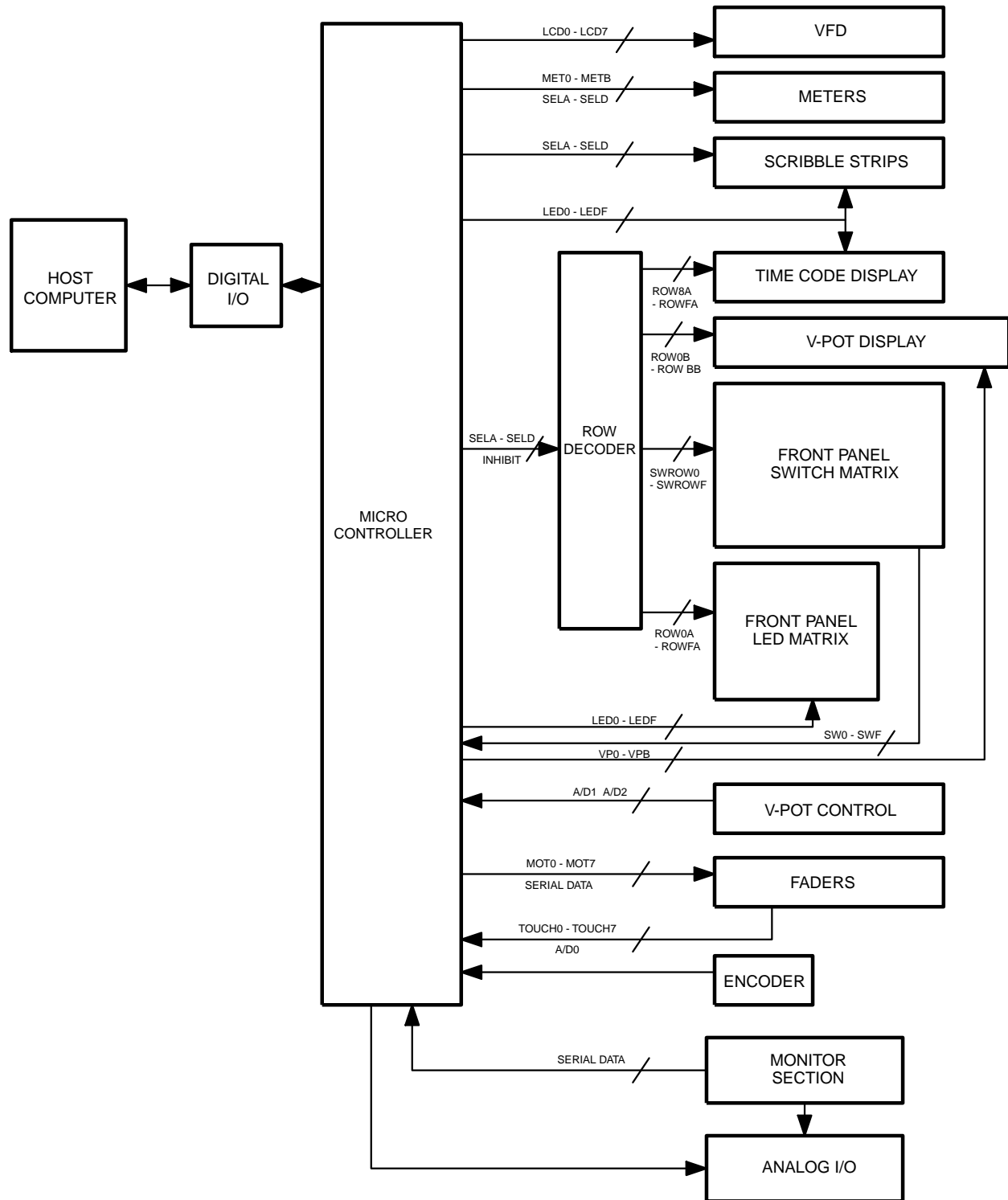

V-POT CONTROL

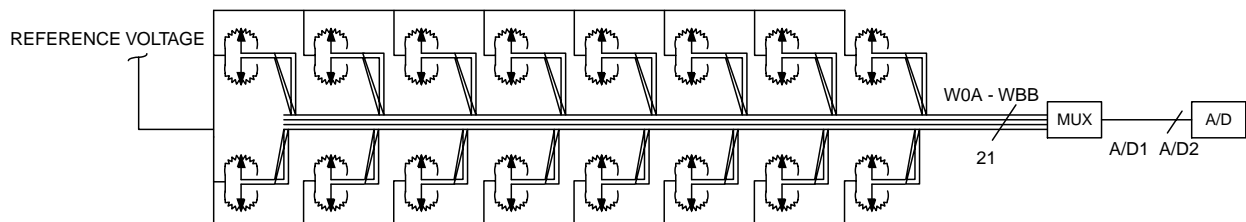

FADER / SERVO

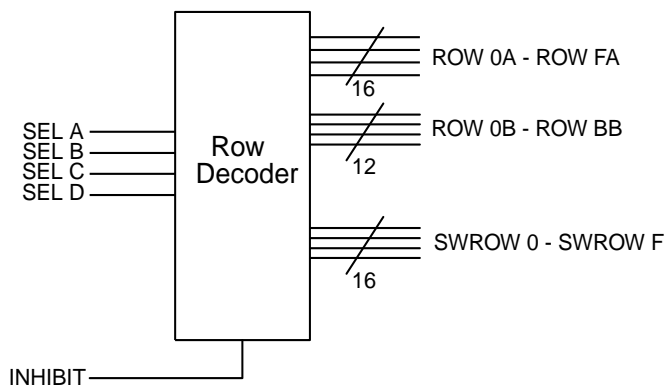
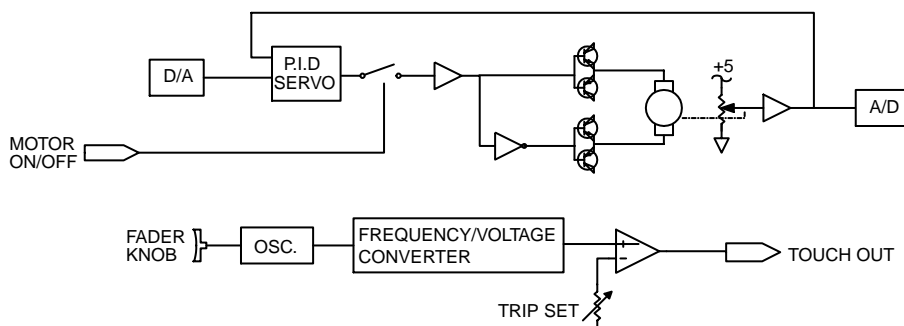

SCRIBBLE STRIP DISPLAY

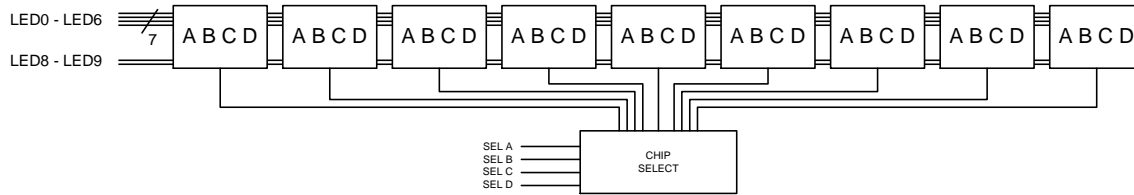

TIME CODE DISPLAY

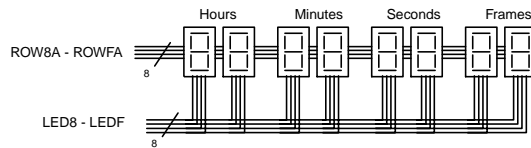

V-POT DISPLAYS

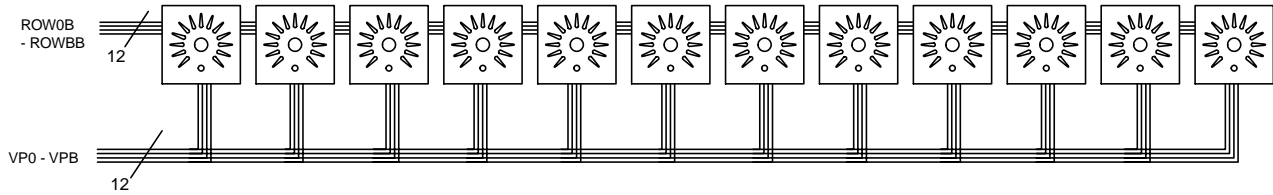

METERS

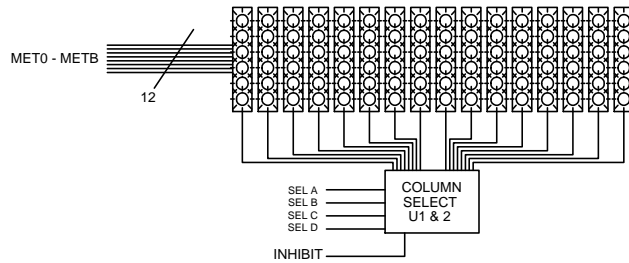

WIRING DIAGRAM

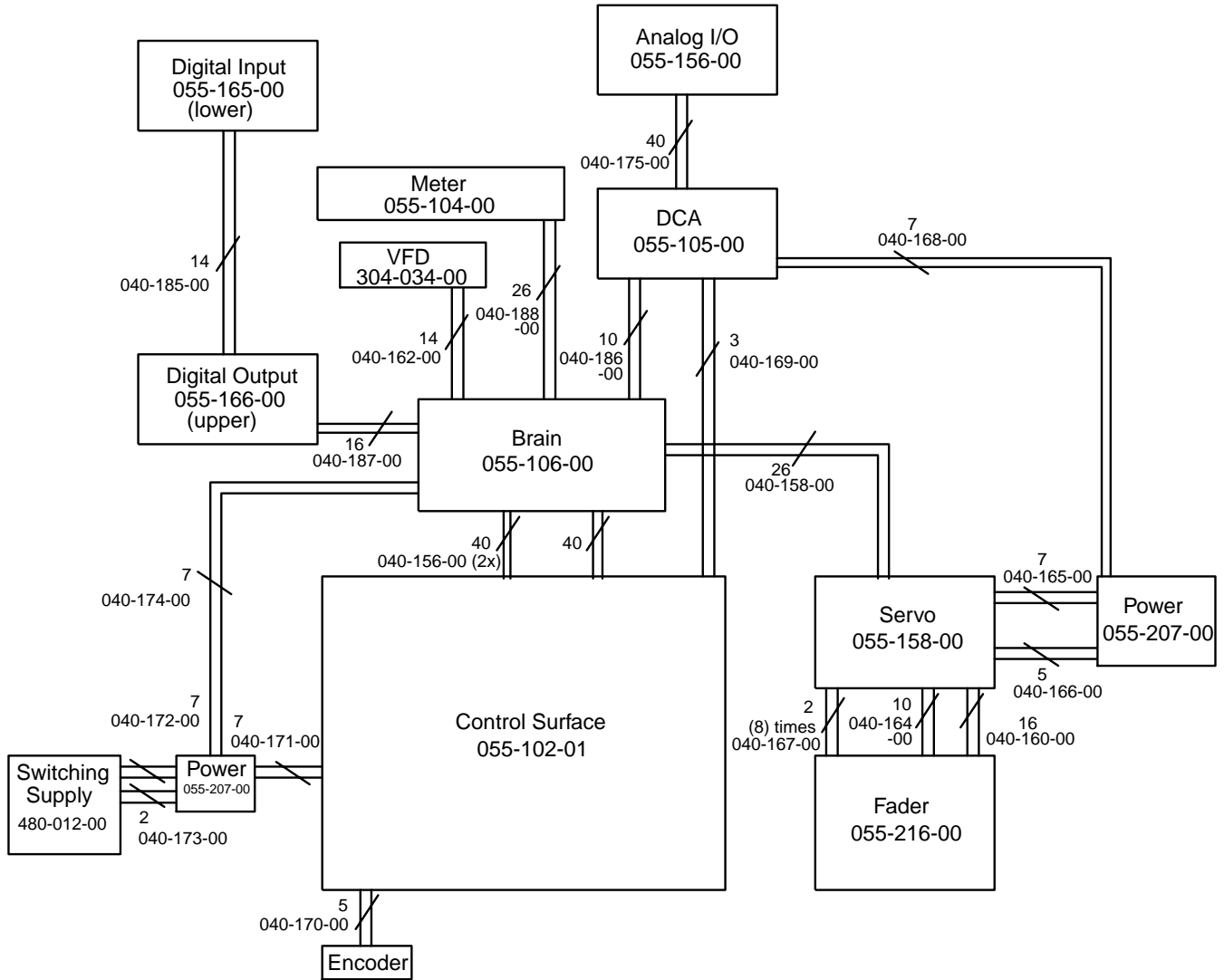

ANALOG BLOCK DIAGRAM

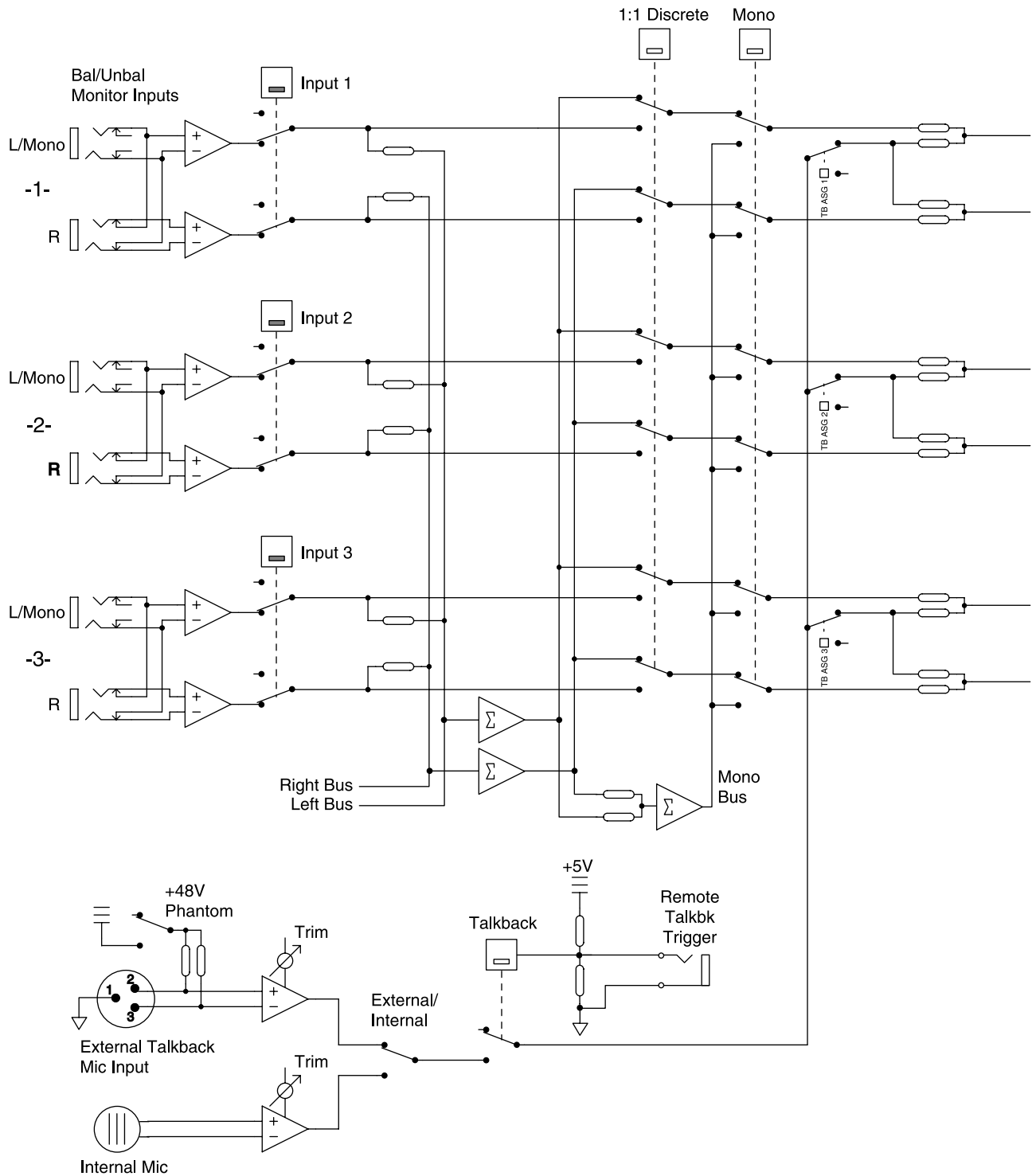

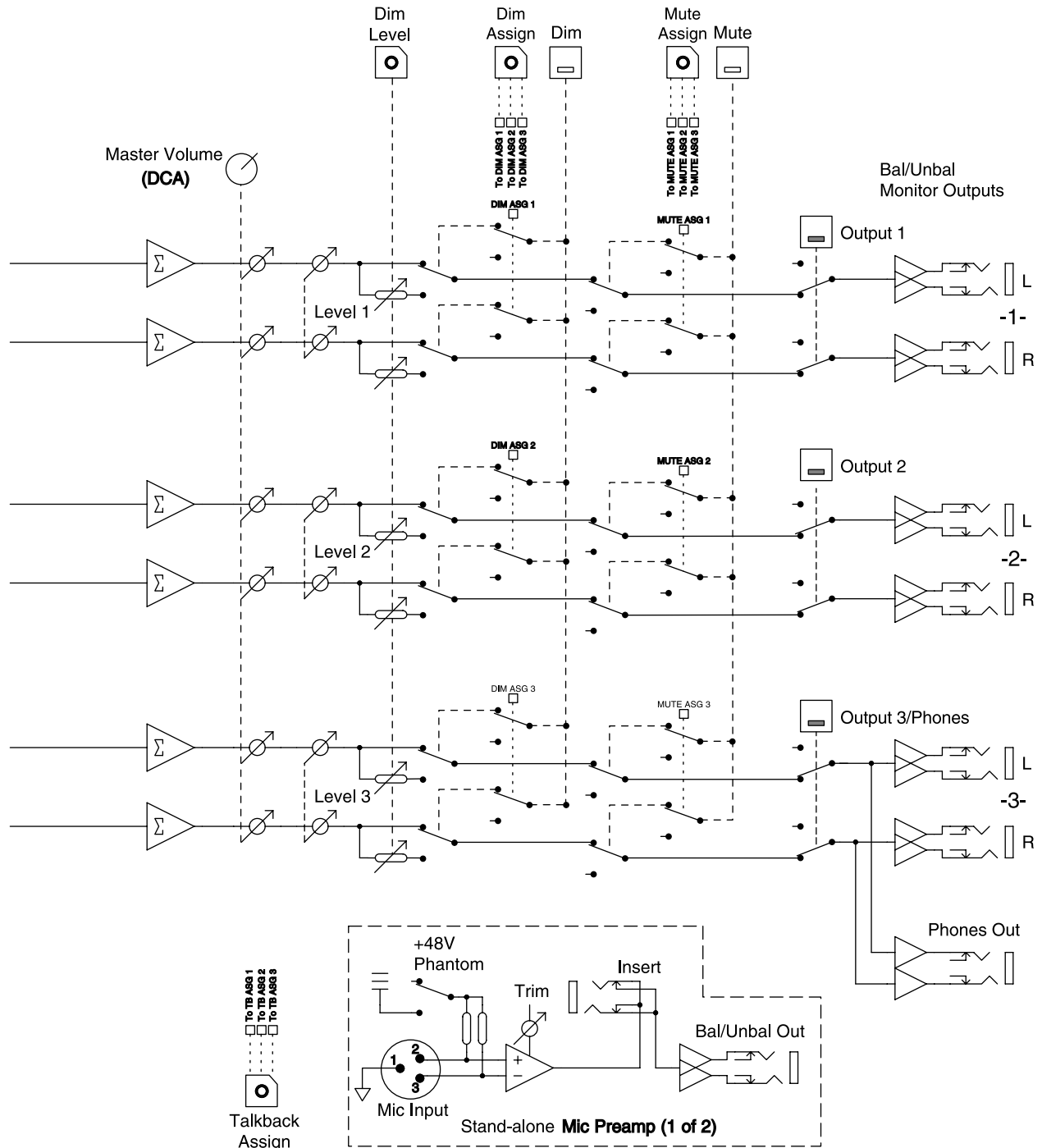

To TB ASSG 1
To TB ASSG 2
To TB ASSG 3

Talkback Assign

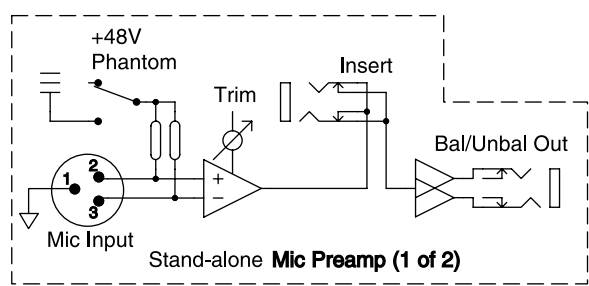

						Mackie Designs Human User Interface (HUI) for Digital Audio Workstations Block Diagram Audio Section v1.0 - 10/97
DC voltage	resistor	XLR jack	TRS jack	balanced input	mix stage	
potentiometer	switch	controller	(on) LED switch (off)	software control		

QUICK PARTS

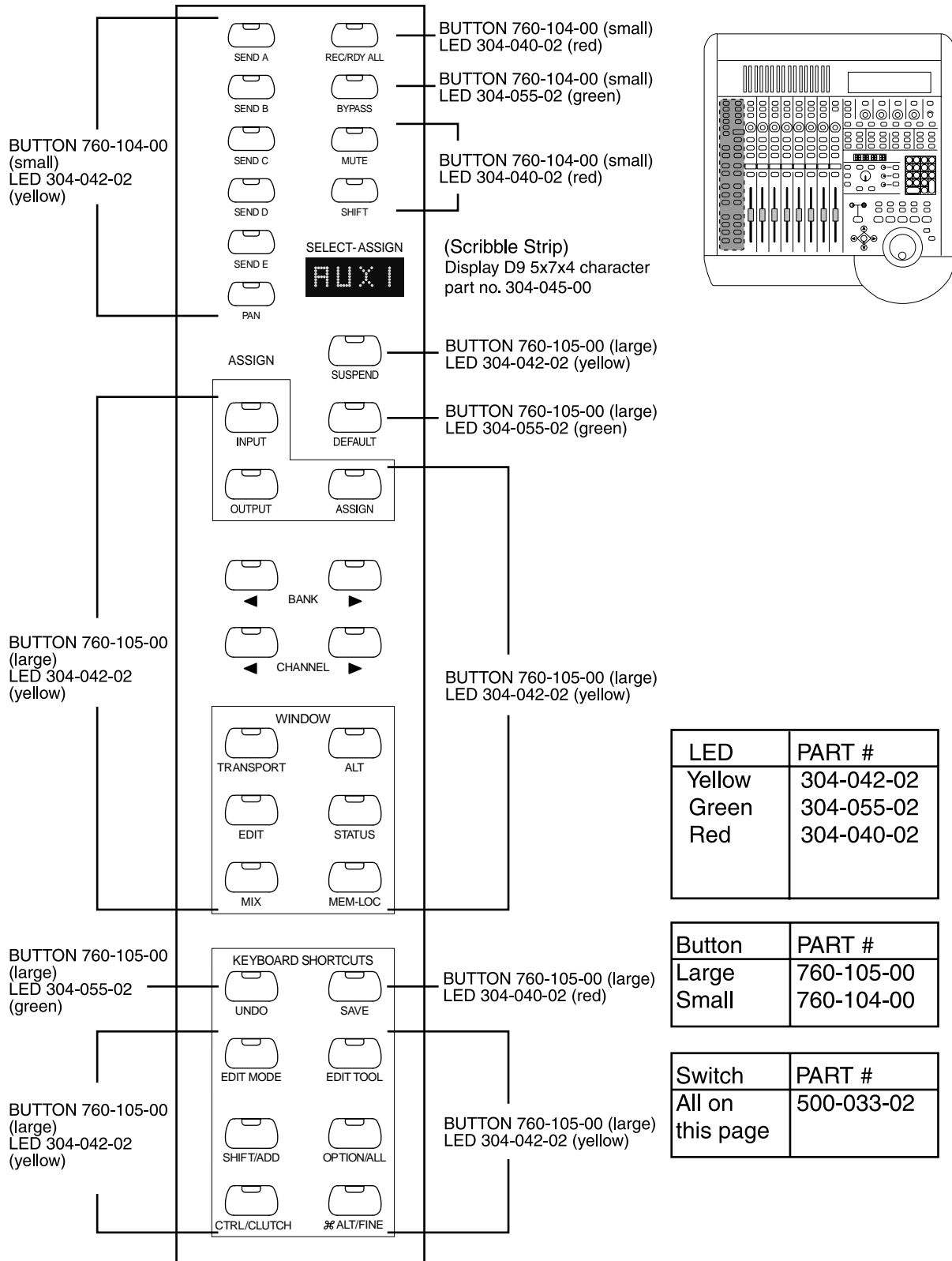

QUICK PARTS

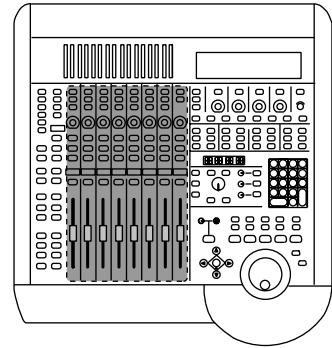

BUTTON 760-104-01
LED 304-040-02 (red)



BUTTON 760-104-02
LED 304-055-02 (green)



BUTTON 760-104-03
LED 304-042-02 (yellow)



PAN/SEND



KNOB 760-063-00
LENS 760-064-00
POT 130-045-00
LED ARRAY 304-026-00

BUTTON 760-105-01
LED 304-057-00 (tri-color)



BUTTON 760-105-02
LED 304-055-02 (green)



BUTTON 760-105-03
LED 304-040-02 (red)



FLUT

SCRIBBLE STRIP
DISPLAY 304-045-00

BUTTON 760-105-04
LED 304-042-02 (yellow)

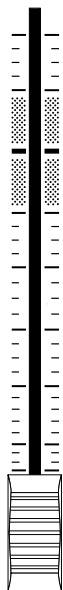

KNOB 760-092-00
FADER 130-041-00
(Motorized)

LED	PART #
Yellow	304-042-02
Green	304-055-02
Red	304-040-02
Tri-color	304-057-00

Switch	PART #
All on this page	500-033-02

QUICK PARTS

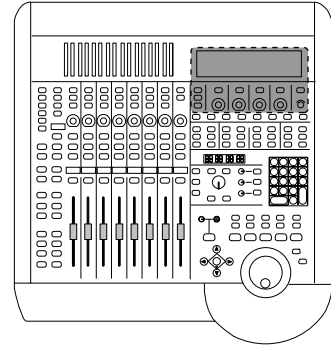

VACUUM FLOURESCENT DISPLAY 304-034-00
40X2 CHARACTERS

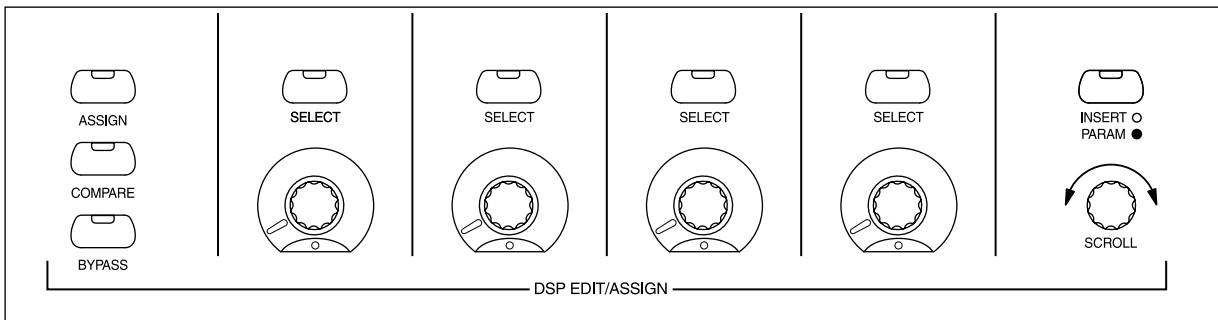
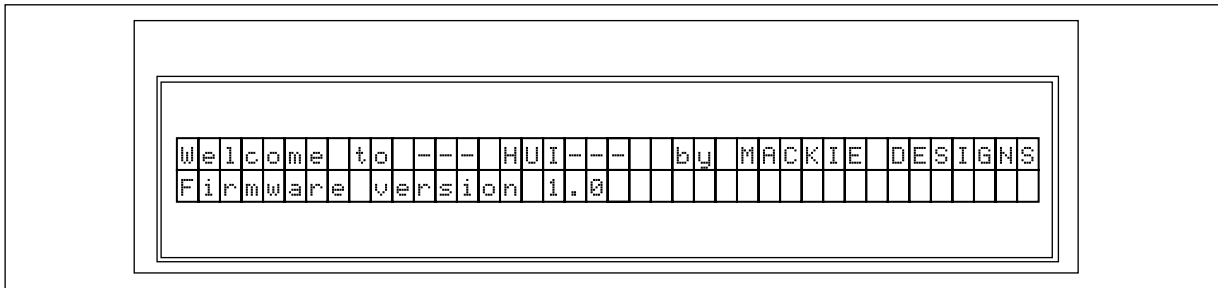

KNOB 760-063-00
 LENS 760-064-00
 POT 130-045-00
 LED ARRAY 304-026-00

KNOB 760-063-00
 POT 130-045-00

ALL BUTTONS 760-104-00
 ALL SWITCHES 500-033-02
 ALL LEDs (on the buttons) 304-055-02, GREEN

QUICK PARTS

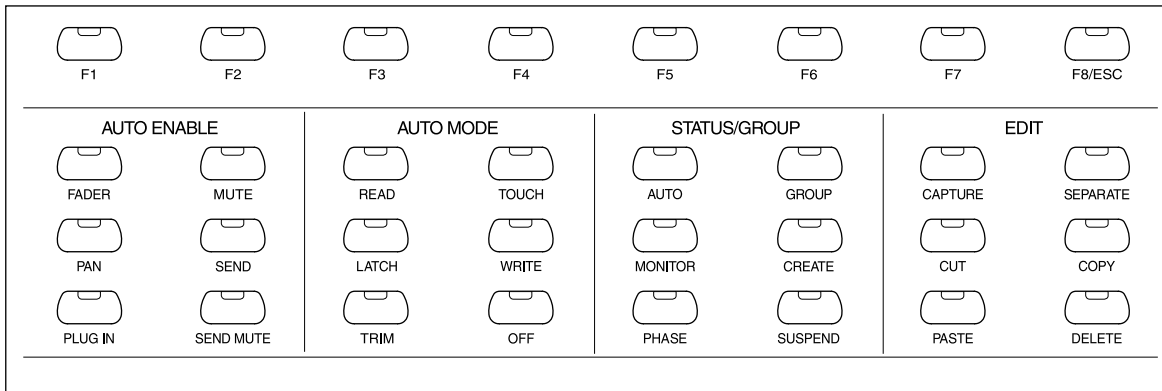
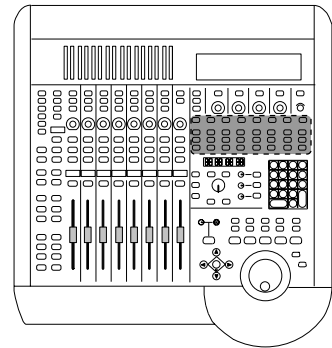

ALL BUTTONS ARE 760-104-00, (SMALL)
 ALL SWITCHES ARE 500-033-02
 ALL LEDS ARE 304-042-02, (YELLOW)

QUICK PARTS

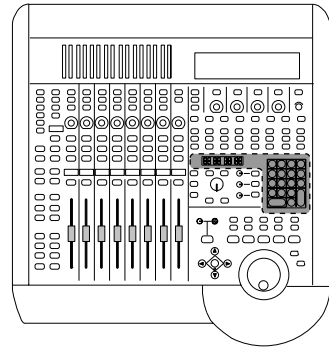

TIME CODE DISPLAY
 PART # 304-035-00, 7 SEGMENT (X8) LED 304-006-00, RED

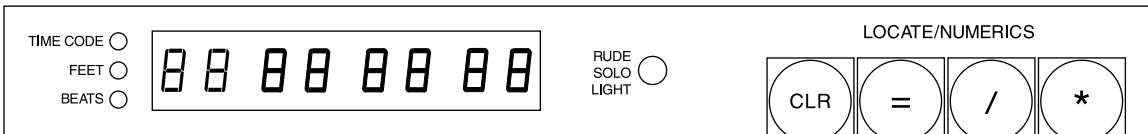

LED 304-027-02, RED

BUTTON	PART NUMBER
1	760-095-01
2	760-095-02
3	760-095-03
4	760-095-04
5	760-095-05
6/9	760-095-06
7	760-095-07
8	760-095-08
DEC. PT	760-095-10
+	760-095-11
-	760-095-12
*	760-095-13
/	760-095-14
=	760-095-15
CLR	760-095-16

ALL KEYPAD SWITCHES ARE
 PART # 500-028-00

QUICK PARTS

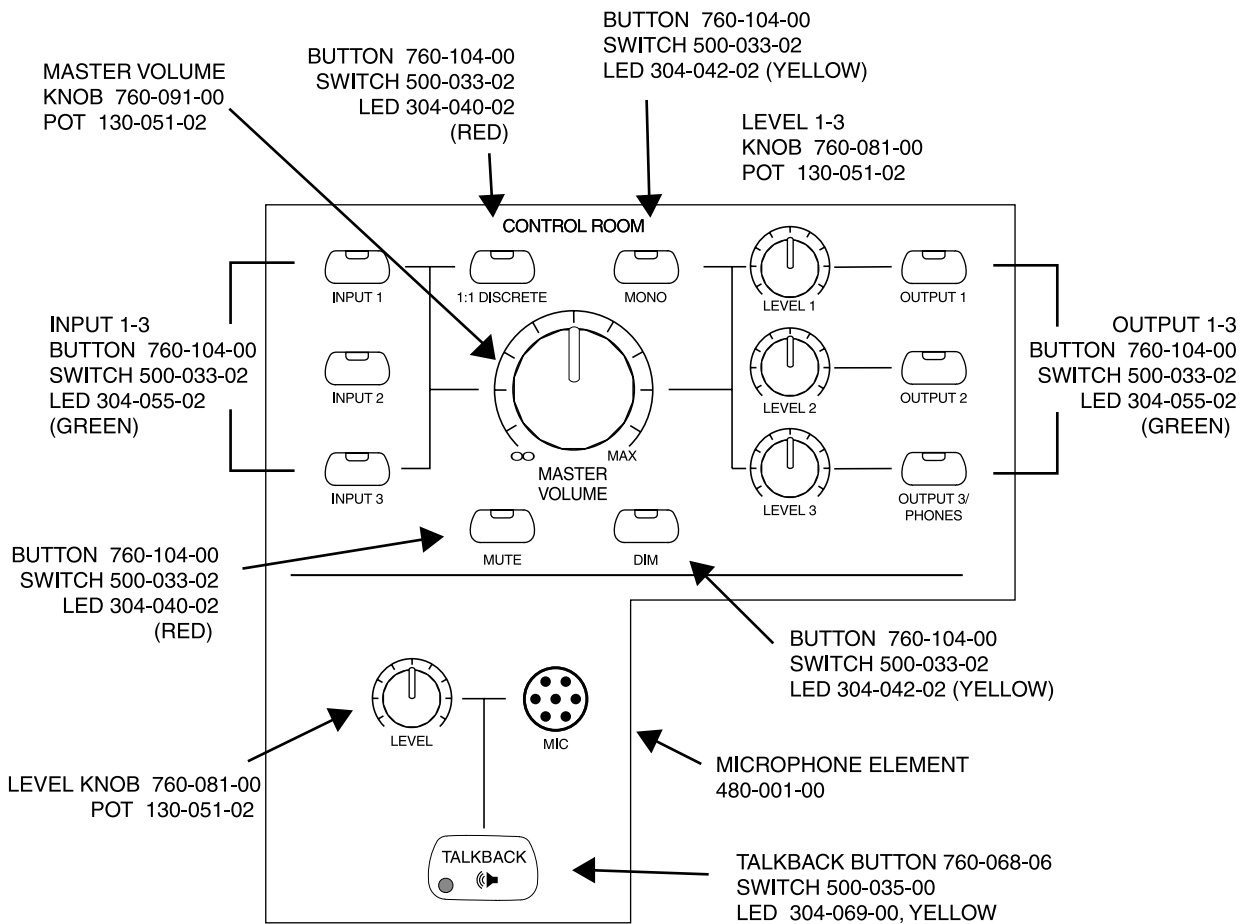
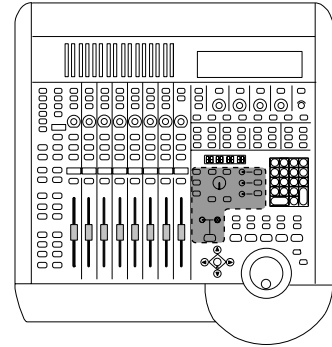

QUICK PARTS

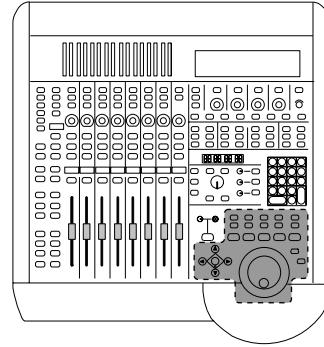

BUTTON	BUTTON #	LED #
REWIND	760-068-01	304-069-00 (YELLOW)
F-FWD	760-068-02	304-069-00 (YELLOW)
STOP	760-068-03	304-069-00 (YELLOW)
PLAY	760-068-04	304-062-00 (GREEN)
RECORD	760-068-05	304-067-00 (RED)
MODE	760-086-01	304-057-00 (TRI-COLOR)
ARROW	760-086-02	

SWITCHES
500-028-00

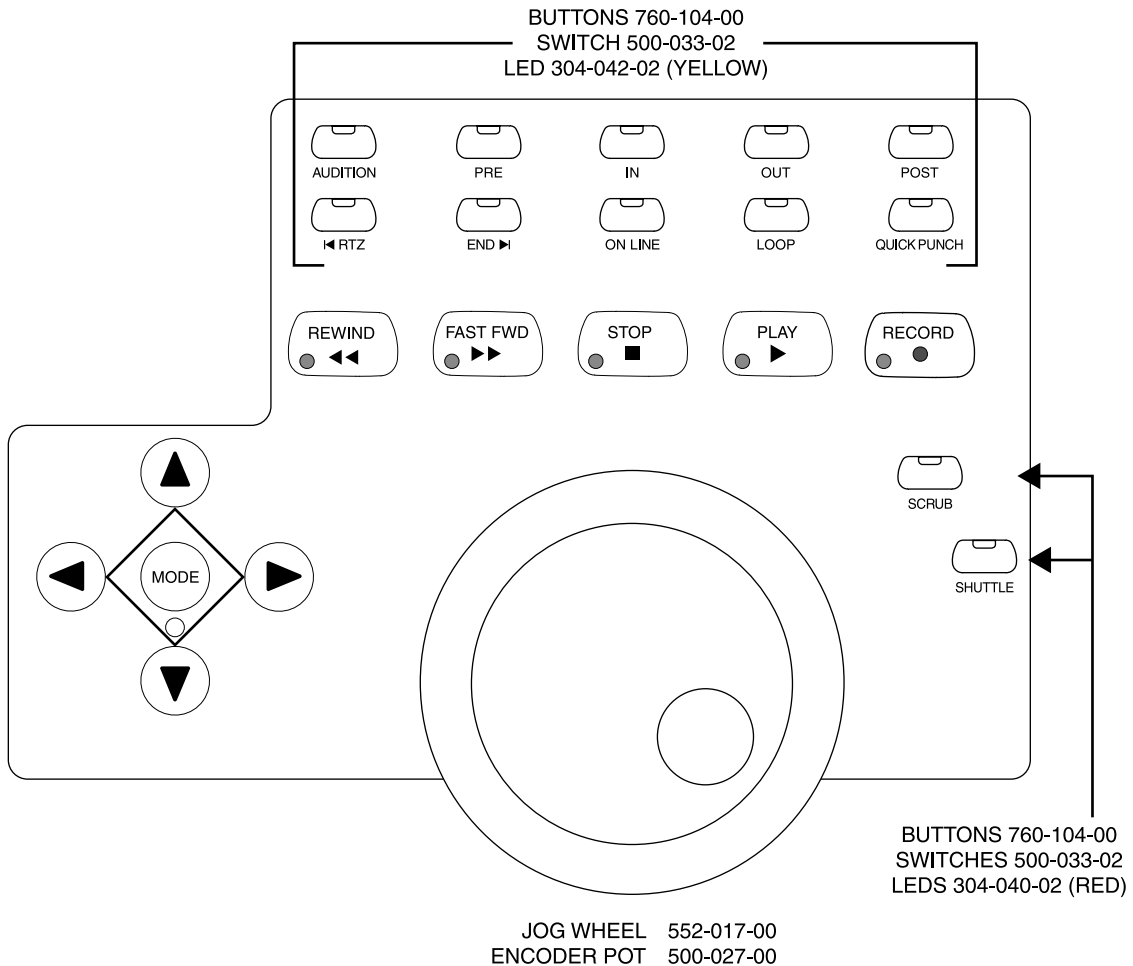

INTERNAL TEST MODES

The HUI has an internal "self-demo" mode and a "system-test" mode which will help you find out if there are any problems with your HUI.

Self-Demo Procedure

This demonstration will make sure the HUI lights up correctly and works properly. If successful, it shows that most of the HUI hardware is working lovely.

1. Turn on the HUI by pressing the POWER rocker switch located on the rear panel.
2. While the display reads "Welcome to the HUI", simultaneously press the CTRL and ALT buttons (located in the lower left area of the front panel). The self-demo will begin and continues as long as the HUI is powered up.
3. To leave the self-demo, turn off the POWER switch.

System-Test Procedure

This is a more involved test procedure which requires a few pieces of extra equipment. The tests usually output a pass or fail message to the VFD, however several tests require the human user to visually verify the functional operation of the LED's, meters, VPots, switches, etc. These routines do not test any of the audio portions of the HUI.

Equipment Requirements for some tests:

- MIDI cable
- Footswitch (normally open momentary switch) on a cable with a 1/4" Jack
- TRS shorting plug (The TIP, RING, and SLEEVE are shorted together)
- DB9 shorting connectors for the SERIAL and EXPANSION ports
 - The RS232 and EXPANSION ports tests require connectors with pins 2 and 3 shorted.
 - The RS422 test requires a connector with pins 3 and 7 shorted and also pins 8 and 2 shorted.
- Baud Rate test cable

Follow the test procedure on the next few pages.

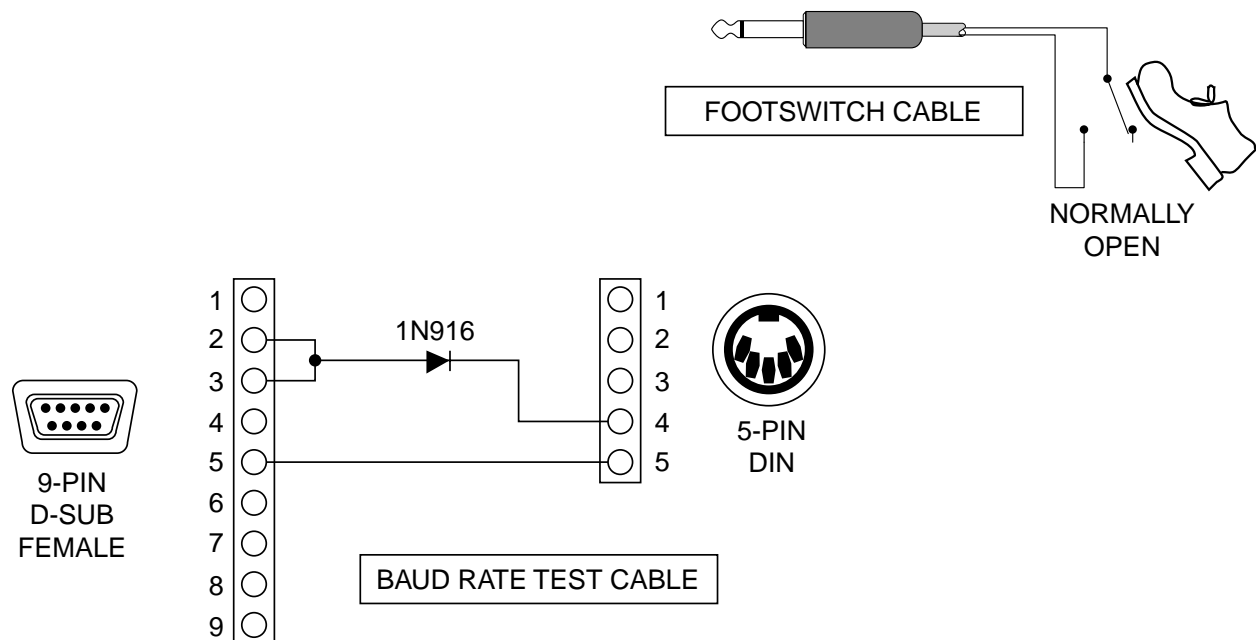

The system-test procedure

Before powering on the unit to be tested, install the TRS shorting plug into its FOOTSWITCH IN 1 jack (on the rear panel) and the footswitch cable into FOOTSWITCH IN 2. To enter the test routines the user must switch on the power, wait for a character display on the VFD, and then press the footswitch. The VFD will display that the fixture is in self test mode, in about 3 seconds, by showing a menu of test categories to choose from.

After entering the test mode, the VFD will display two rows of selections for tests. These are the top level menu selections. One row will be flashing indicating that these selections are instantly available by pushing the corresponding switch in the DSP section in the upper right top area on the HUI. There are 4 VPots in the DSP section, each has a SELECT switch above it. These switches correspond to the columns which are displayed in the VFD and will be called the **selection switches** in this procedure. There is one additional switch to the right of these (the INSERT/PARAM switch) which will toggle the flashing row in the menu and is also used as an exit switch.

Pressing the selection switch for the test in the flashing row will select that test. As an example, if you wanted to test the meters you would select **LED's** on the flashing menu by pressing the switch that is directly below the column that **LED's** is in, then you would select **Meters**, which appears in the second menu after making the first selection, in a similar manner. If the test you want is not in the flashing row you can toggle to the row you want by pressing the INSERT/PARAM switch on the right of the 4 SELECT switches.

If you wish to exit before running the test press the exit switch (the INSERT/PARAM switch). Once you are within a test, an exit is usually done by pressing the footswitch.

On the following pages is a list of all tests that should be done. They are arranged according to their appearance in the top level menu. Under each numbered title are the names of the individual tests to be done. They can be done in any order as long as the test person makes sure to do all of them. Some tests are redundant with others in this procedure, when this is the case it will be indicated so it will not be necessary to duplicate tests.

Power on the unit after you have installed the test cables and are ready to test.

1.0 System \ ROM RAM EEPROM

1.1 ROM:

Select **System** on the flashing menu and **ROM** in the second menu. The Brain board in the HUI verifies the ROM is working.

1.1.1 Verify the VFD displays D6E7 in its lower right corner when the test is done. This test exits on its own.

1.2 SRAM:

Select **System** on the flashing menu and **SRAM** in the second menu. The Brain board in the HUI verifies the RAM is working properly.

1.2.1 Verify there are no error messages in the VFD returned from the self test. Press the footswitch to exit.

1.3 EEPROM:

Select **System** on the flashing menu and **EEPROM** in the second menu. The Brain board in the HUI verifies the EEPROM is working properly.

1.3.1 Verify there are no error messages in the VFD returned from the self test. This test exits on its own.

2.0 LEDS \ Switch LEDS Meters

2.1 Switch LED's and Color Verification:

This test flashes all LED's to show the user any possible unlighted LED's. Select **LED's** on the flashing menu and **SW LED's** in the second menu.

The AUTO button in each of the 8 channels has a tri-colored LED. Make sure the appropriate color flashes during its color set (it will not flash during yellow mode).

2.1.1 Check each and every LED carefully to see that there are no blemishes on the buttons or in the windows for the LED's. Make sure that each LED is properly aligned under its button window. Also verify that all LED's are of even brightness with each other.

2.1.2 Press the footswitch and the test flashes all the red LED's while leaving all the rest of the LED's on. If a different color than red is flashing then the unit needs repair.

2.1.3 Press the footswitch and the test flashes all the green LED's while leaving all the rest of the LED's on. If a different color than green (except Play) is flashing then the unit needs repair.

2.1.4 Press the footswitch and the test flashes all the yellow LED's while leaving all the rest of the LED's on. If a different color than yellow is flashing then the unit needs repair. Press the footswitch to exit this test.

2.2 Meters:

This test sequentially illuminates all 12 segments of all meters in a display showing the meter bars filling up. The Master Level pot (in the MONITOR section) can be used to adjust the speed of the display. Select **LED's** on the flashing menu then select **Meters** in the second menu.

2.2.1 Verify that each segment pair individually lights up and stays on as the test scans through all segments. No segment should turn off until all segments are lit, then all segments will turn off simultaneously and the test will repeat itself.

2.2.2 Verify that all the LED's in the meter have the correct color and are in the correct order. They should match the color scheme of the meters in other units. Also make sure that there are no visible blemishes or scratches in the lighted display. Press the footswitch to exit this test.

3.0 Switches \ Panel SW Foot SW 1,2

3.1 Panel Switches:

This test prompts the user to press every switch on the control panel and indicates which switches need to be pressed by flashing the LED of any switch that has not been pressed. It also displays all switches' hex codes on the VFD when any switch is pressed. For switches with no LED the VFD will display the switch is working when pressed. Select **Switches** on the flashing menu and **Panel SW** in the second menu.

3.1.1 Verify that every switch (including switches without LEDs such as the transport, keypad, arrow buttons, etc.) causes a display change on the VFD and that the corresponding flashing LED extinguishes after being pressed. There should also be an audible click from the back of the unit when any switch is pressed. Press the footswitch to exit.

3.2 Footswitch Ports:

Select **Switches** on the flashing menu then select **Foot SW** in the second menu. The VFD should indicate that Footswitch 1 is pressed and Relay Out 1 is on.

3.2.1 Remove the TRS shorting plug from the FOOTSWITCH IN 1 jack on the rear panel of the fixture and press the footswitch. The VFD should indicate that Footswitch 2 is pressed and Relay Out 2 is on for each time the footswitch is pressed. You should also hear the relay click when the footswitch is pressed.

3.2.2 Move the footswitch cable from the FOOTSWITCH IN 2 jack to the FOOTSWITCH IN 1 jack. Press the footswitch and the VFD should indicate that Footswitch 1 is pressed and Relay Out 1 is on. You should also hear the relay click when the footswitch is pressed.

3.2.3 Restore the footswitch cable and the TRS shorting plug to their original jack positions and press the footswitch to exit this test.

4.0 Controllers \ Faders Vpots Mon Pots Encoder

4.1 Fader Position:

Select **Controllers** from the flashing menu then select **Faders** in the second menu.

4.1.1 Verify that all scribble strip displays are aligned properly in their windows and are even with each other.

4.1.2 Verify that all fader position values on the scribble strips are 0 when the faders are moved to the bottom position and that all values go to 1023 when the faders are moved to the top position. Sometimes the rubber stops in the faders can prevent full travel, in that case it is sometimes possible to "break in" the faders by gently pushing the faders into the stops so that they can read the full range of values. It is mandatory that all the faders read from 0 to 1023 when they are moved to the end positions and left unassisted. Press the footswitch to exit.

4.2 VPots:

This test shows the ADAC codes for each VPot in its corresponding scribble strip when it is rotated. The VPots that are in the DSP section (under the SELECT switches) have displays in the VFD showing their codes. Select **Controllers** on the flashing menu then select **Vpots** in the second menu.

4.2.1 Slowly rotate each VPot both directions and check for its readout to move through alphanumeric values in its corresponding display. The codes displayed should be between A000 - A255 to B000 - B255. It is typical for the codes to skip values near the ends of the A and B ranges by as much as 35 units, i.e. A035 -A215 to B035 - B215.

4.2.2 When the VPot is not being touched, verify that each display has a stable readout with a difference in number of no more than +/- 1. Press the footswitch again to exit.

4.3 Monitor Pots:

This test shows the ADAC codes for each monitor pot in the left 4 scribble strips above the faders when each pot is rotated. Select **Controllers** on the flashing menu then select **Mon Pots** in the second menu.

4.3.1 Verify that each pot changes value from 000 to 127 when they are rotated from MIN to MAX.

4.3.2 Turn each pot to the center position and verify that the codes are stable and do not change more than +/- 1. Typical values in the center are 63 to 65. Press the footswitch to exit.

4.4 Jog Wheel Encoder:

This test shows the ADAC codes for the jog wheel in its scribble strip, in the upper left area of the HUI, when the jog wheel is rotated. Select **Controllers** on the flashing menu then select **Encoder** in the second menu.

4.4.1 Slowly rotate the jog wheel (encoder) both directions and verify the codes displayed are 000 to 255. The display should have a stable readout with no change in number when the jog wheel is not being touched. Press the footswitch to exit. Clockwise rotation will increment the displayed numbers, Counter-clockwise will decrement them.

5.0 COM Ports \ MIDI Port RS232-422 Expander Baud Rate

5.1 MIDI Continuity:

Install the MIDI cable into the MIDI IN and MIDI OUT jacks on the rear panel. Select **Comm Ports** from the flashing menu and select **MIDI Port** in the second menu. The VFD should display a message that it is testing the MIDI port.

5.1.1 Disconnect the MIDI cable and the VFD should display a message that the MIDI port is bad. Reinstall the MIDI cable and verify that the message returns to its previous state. Press the footswitch to exit this test.

5.2 RS232/RS422 Continuity:

Install the RS232 shorting connector into the SERIAL PORT on the rear panel and press the switch next to the connector to the out position. Select **Comm Ports** from the flashing menu and select **RS232-422** in the second menu. The VFD should display a prompt to put in the RS232 shorting connector and then it goes into testing the port.

5.2.1 Disconnect the RS232 connector and the VFD should display a message that the RS232 port is bad. Reinstall the RS232 connector and verify that the message returns to its previous state.

5.2.2 Remove the RS232 connector and install the RS422 shorting connector into the SERIAL PORT. Press in the switch next to the connector then press the footswitch. The VFD will prompt to put in the RS422 shorting connector and then it goes into testing the port.

5.2.3 Disconnect the RS422 connector and the VFD should display a message that the RS422 port is bad. Reinstall the RS422 connector and verify that the message returns to its previous state. Remove the RS422 connector and press the footswitch to exit this test.

5.3 Expansion Port Continuity:

Install the RS232 shorting connector into the EXPANSION PORT on the rear panel. Select **Comm Ports** from the flashing menu then select **Expander** in the second menu. The VFD should display a prompt to put in the shorting connector and then it starts testing the port.

5.3.1 Disconnect the RS232 connector and the VFD should display a message that the Expander port is bad. Reinstall the connector and verify that the message returns to its previous state. Press the footswitch to exit.

5.4 Baud Rate:

Install the baud rate test cable into the EXPANSION PORT and the MIDI IN jack on the rear panel. Select **Comm Ports** from the flashing menu then select **Baud Rate** in the second menu. The VFD should display a prompt to put in the test cable and then it goes into testing the port.

5.4.1 Disconnect the test cable from the MIDI IN and the VFD should display a message that the Baud Rate fails. Reinstall the cable and verify that the message returns to its previous state. Press the footswitch to exit.

6.0 Servos \ Calibrate Squarewaves Sinewaves Motor Switch

6.1 Motor Servo: Calibrate

Select **Servos** from the flashing menu then select **Calibrate** in the second menu. At this point all the faders should move almost to the top of their travel and the scribble strips above the faders should read something close to 1000. There will be a little motion in all of the faders as they are in this holding position. This is the effect of the dither signal sent to each fader to minimize the errors for calibration.

6.1.1 If the numbers on the scribble strips are not 1000 then adjust the following trimpots on the Servo board so that the gain reading is 1000. The strip displays will twiddle about +/- 1 unit so take care to center the adjustment so that 1000 is displayed most of the time.
Channel 1 = R43, Channel 2 = R46, Channel 3 = R51, Channel 4 = R54, Channel 5 = R59,
Channel 6 = R62, Channel 7 = R67, Channel 8 = R70

6.1.2 Press the footswitch and the next test will automatically be activated. It is in this test that all the faders will move up and down together at the same time. Use the MASTER LEVEL pot on the control surface to set the speed of the faders to the slowest motion. Verify that all faders move at the same rate through the complete range of travel. There should be no more than 2 millimeters difference in positional variation from fader to fader.

Press the footswitch to exit.

6.2 Motor Servo: Squarewave

Select **Servos** from the flashing menu then select **Squarewave** in the second menu. In this test all faders will jump top to bottom quickly.

6.2.1 Use the MASTER LEVEL pot in the MONITOR section to vary the cycle time between jumps. Verify that at any cycle rate that the faders do not hit the end stops inside the faders themselves.

6.2.2 Verify that all faders move together at all speeds. At some speeds some faders will appear slightly "lazy" lagging behind the rest of the faders in line. This is acceptable if the "lazy" faders are not extremely lazy. At the highest cycle speed, all faders should move equal

distance about the centerline of their travel. The faders will decrease their range of travel as the speed of the cycle is increased. Press the footswitch to exit.

6.3 Motor Servo: Sinewave

Select **Servos** from the flashing menu then select **Sinewave** in the second menu. All faders should move in a smooth sinusoidal motion with no unusual noises. Use the MASTER LEVEL pot to vary the speed of the cycle.

6.3.1 Verify at all cycle rates that the faders do not shake (skate), slip, or stop out of their respective positions. It is normal for the faders to decrease their range of travel as the speed of the cycle is increased. If the touch sense circuit is out of calibration it will cause a meter to come on and can cause its corresponding fader to stop moving. Recalibration will then be necessary.

6.3.2 Recalibration is done by adjusting the following touch sense trimpots (accessible through the holes on the fader board). While the sinewave pattern of the faders are in operation, adjust the trimpot for each fader so that its corresponding meter display just turns on, then back off 1 complete turn.

Channel 1 = R113, Channel 2 = R149, Channel 3 = R213, Channel 4 = R249, Channel 5 = R313, Channel 6 = R349, Channel 7 = R413, Channel 8 = R439

6.3.3 The meters display touch sense detection and the aftertouch algorithm. The left section of each meter shows that touch has been detected. The right section shows the aftertouch delay.

Touch the knobs of each individual fader and verify its corresponding display turns on.

6.3.4 After all faders have been adjusted, verify that touching all 8 faders simultaneously causes all meter LED's in both sections of all 8 meters to light fully on. If the unit fails to light all meters, the touch sense pots on the Fader board may have to be readjusted. Do not touch anything but the fader knobs while doing this test. It is normal for the left bar of the first meter to be dim when all 8 meters are lit.

6.4 Motor Servo:

Select **Servos** from the flashing menu then select **On-Off** in the second menu. This test verifies that the switching on the Servo board is working.

6.4.1 Verify all faders will move up and down several times and then stop in the center of their travel. Allow this action to repeat at least a couple times. Press the footswitch to exit.

7.0 Displays \ V.F.D. Scribbles V-ring Timecode

7.1 VFD:

Select **Displays** on the flashing menu then select **VFD** in the second menu. The VFD display should show numbers 0 thru 7 interconnected with lines and a visible scan line moving through them.

7.1.1 Make sure that the display stays consistent to this description throughout at least 5 scan cycles. If the display "blips", misses characters or changes, the unit will need repair. Press the footswitch to exit.

7.2 Scribble Strip Displays:

Select **Displays** on the flashing menu then select **Scribbles** in the second menu. This test sequentially scrolls the displays of all scribble strips to show that all pixels light up correctly.

7.2.1 The nine scribble strips on the control surface will individually scroll data values in their displays in a sequential manner. The first display shows 1XXX, the second display shows 2XXX, the third display shows 3XXX, etc. up to 9XXX, where the XXX are values of 000 to 255. Verify that there are no missing pixels and that all strips have equal intensity and are aligned properly. Press the footswitch to exit.

7.3 VPot Ring Displays:

Select **Displays** on the flashing menu then select **V-ring** in the second menu. This test sequentially lights each individual segment in each VPot indicator ring. The speed of rotation can be adjusted with the Master Volume pot in the MONITOR section.

7.3.1 The displays start with the leftmost VPot and move in sequence to the rightmost VPot. Each VPot ring starts its display from the "7 o'clock" segment and lights each individual segment one at a time in a clockwise direction. It then rotates back in a counterclockwise direction and ends on a period (dot) before progressing to the next VPot. Verify all segments of all VPot displays light according to this description. Press the footswitch to exit.

7.4 Time Code Display:

Select **Displays** on the flashing menu then select **Timecode** in the second menu. This test illuminates all digits simultaneously in the Time Code display with a sequence of numbers 1 to 9 along with a period in each digit. The speed of display can be adjusted with the Master Volume pot in the MONITOR section.

7.4.1 Verify all digits have equal intensity and that all appropriate segments light up for each number and the period.

7.4.2 Also check that each digit is in proper alignment with the others. Press the footswitch to exit.

8.0 Audio Speaker

8.4 Select **Audio** in the first menu. Select **Speaker** in the second menu.

8.4.1 Verify that there is an audible pattern of clicks and beeps from the speaker in the HUI. The pattern will be in the form of Click...Click.Click.Click...Click....Beep...Beep. Press the footswitch to exit.

9.0 Servo Adjustment

NOTE: If the HUI under test has a 50K trim pot next to U3 of the servo board, perform the following adjustment.

Set the multimeter for a DC Volts measurement. There is a trimpot on U3 of the Servo board on the fixture that needs to be adjusted so that the meter reads 4.9 Vdc (+/-0.1). Apply the meter from the chassis ground to the heat sink tab of U3.

HUI Parts List

Final Assembly parts B2-B4
 (includes all chassis parts, screws and fasteners etc.)

PCB Assembly parts

Control Surface B5-B7
 Fader B7
 Meter B8
 DCA B9
 Brain B10
 Power Supply B11
 Analog I/O B12
 Servo B13-B14
 Digital In B15
 Digital Out B16
 ESD B17

Updated Parts List (July 2001) B18-B19

NOTE: Please see the updated parts list on page B18 and B19

MACKIE. HUI SERVICE MANUAL

QTY	PART NO.	DESCRIPTION
1	040-158-00	RIB 28GA 34C 2.75IN PLZD
1	040-165-00	RIB 18GA 7C .156 7.5IN
1	040-166-00	RIB 18GA 5C .156 8.0IN
1	040-168-00	RIB 18GA 7C .156 6.00IN
1	040-169-00	CBL ASSY 24GA 3/2C .1 17.
1	040-170-00	RIB 22GA 5C .100 2.00IN
1	040-171-00	RIB 18GA 8C .156 6.0IN
1	040-174-00	RIB 18GA 7C .156 4.0IN
1	055-102-01	PCB ASSY CONTROL SURFACE (see page B5-B7)
1	550-293-00	BRKT KEY PAD
1	055-105-00	PCB ASSY DCA (see page B9)
2	410-005-00	INSL SILPAD TO-220
1	055-106-00	PCB ASSY BRAIN (see page B10)
1	055-156-00	PCB ASSY ANALOG I/O (see page B12)
1	055-158-00	PCB ASSY SERVO (see page B13-B14)
1	055-165-00	PCB ASSY DIGITAL INPUT (see page B15)
1	055-166-00	PCB ASSY DIGITAL OUTPUT (see page B16)
1	040-187-00	RIB 28GA 16C TRANS 4.50
1	055-216-00	PCB ASSY FADER (see page B7)
8	040-167-00	DIS 22GA 1007 2C .100 3IN
8	400-083-00	2P .100X1 22GA END
8	610-017-05	WIR 22GA 1007 RED 3 ST1
8	610-023-01	WIR 22GA 1007 BLU 3 ST1
1	055-222-00	PCB ASSY ESD (see page B17)
1	040-164-00	RIB 28GA TRANS 10C 3.75"
8	100-073-00	RES CF .125W 5% 10K OHM
1	400-078-00	HDR 10P .1X2 STR LCK SHRD
1	080-042-00	SA JOG SWITCH
1	500-027-00	SW ENCODER OPTI 128 CYCLE
1	550-289-00	BRKT ENCODER
1	705-022-00	NUT HEX 3/8 (500-027-00)
1	710-001-00	WASH STAR 3/8 OD .02 THK
1	710-025-00	WASH FLT AL .437IDx.628OD
1	080-043-00	SA DISPLAY
1	040-162-00	RIB 28GA 14C TRANS 5.25IN
1	055-104-00	PCB ASSY METER (see page B8)
1	040-188-00	RIB 28GA 26C TRANS 5.25
1	304-034-00	DISPLAY VFD 40X2 CHARS
1	550-288-00	BRKT MTR BRIDGE
3	706-047-04	STDF BL 6-32X.375 STL PEM
6	706-047-06	STDF BL 6-32X.500 STL PEM
9	700-028-00	SEMS 6-32X1/4 PHP BLKZC
1	080-045-03	SA EPROM PRGMD V1.45 (next 3 items)
1	329-034-00	IC 64 X 8 EPROM 27C512
1	840-106-00	LBL EPROM
1	860-011-05	EPROM SOFTWARE V1.45
1	080-075-00	SA PWR SPLY NOTE: 120 V MODEL
1	080-075-01	SA PWR SPLY NOTE: 230 V MODEL
1	080-075-02	SA PWR SPLY NOTE: 100 V MODEL
1	040-057-00	18GA 1015 GRN 6IN QD/LUG
1	400-210-00	TERM QDISC .250 F 18-22GA
1	611-015-02	WIR 18GA 1015 GRN 6IN ST2
1	711-001-00	LUG NO.6 SOLDER STAR
1	040-172-00	RIB 18GA 6C .156 5.50IN
1	040-173-00	18GA 1010 3/2C BRN/BLU 5

Parts Numbering guide

040-	Cables
055-	Finished PCB Assy
100-	Pots and resistors
200-	Capacitors
300-	Semiconductors
400-	Jacks/Connectors
500-	Switches
510-	Fuses
550-	Chassis Metalwork
600-	Transformers
601-	Inductors
610-	Wires and Cables
640-	AC line cords
700-	Hardware
760-	Knobs/Plastic
770-	Fans
790-	Misc./Packing
800-	Printed Material
860-	EPROM



QTY	PART NO.	DESCRIPTION	
1	400-144-00	3P .156 F 18GA END	
2	400-210-00	TERM QDISC .250 F 18-22GA	
1	611-039-02	WIR 18G 1010 BLU 5.00 ST2	
1	611-040-04	WIR 18G 1010 BRN 5.00 ST2	
1	040-182-00	18GA 1010 BRN 6.25 QD	
1	400-210-00	TERM QDISC .250 F 18-22GA	
1	611-040-03	WIR 18G 1010 BRN 6.25 ST2	
1	040-183-00	18GA 1010 BLU 7.75 QD	
1	400-210-00	TERM QDISC .250 F 18-22GA	
1	611-039-01	WIR 18G 1010 BLU 7.75 ST2	
1	040-184-00	18GA 1015 GRN 2.50 QD	
1	611-015-04	WIR 18GA 1015 GRN 2.5 ST2	
1	711-001-00	LUG NO.6 SOLDER STAR	
1	040-279-00	DIS 18G 1010 GN/YL 9 QDLG	
1	400-210-00	TERM QDISC .250 F 18-22GA	
1	611-038-01	WIR 18GA 1010 GN/YL 9 ST2	
1	711-001-00	LUG NO.6 SOLDER STAR	
1	055-207-00	PCB ASSY PWR SPLY (see page B11)	
AR	740-011-00	HEATSHRINK TUBE 2:1 .50ID	
1	400-009-00	IEC W/FUSEHOLDER	
1	480-012-00	SW PWR SPL 60W +5/+12/-12	
1	500-013-00	SW RCKR SPST 6A PWR SFTY	
1	510-040-00	FUSE SB 1.25A 5X20	NOTE: FOR 120 V MODEL
1	510-039-00	FUSE SB 630mA 5X20	NOTE: FOR 230 V MODEL
1	510-015-00	FUSE SB 1.6A 5X20	NOTE: FOR 100 V MODEL
1	550-290-00	BRKT PWR SPLY	
6	704-001-02	PEMNUT 6-32 .054 STL	
1	704-023-03	STUD 6-32X.500 STL FLSH	
4	706-036-02	STDF 6-32X.250L STL PEM	
4	706-047-04	STDF BL 6-32X.375 STL PEM	
1	706-047-10	STDF BL 6-32X.750 STL PEM	
1	600-032-00	XFMR HUI 120V	NOTE: FOR 120 V MODEL
1	600-032-01	XFMR HUI 230V	NOTE: FOR 230 V MODEL
1	600-032-02	XFMR HUI 100V	NOTE: FOR 100 V MODEL
1	611-040-02	WIR 18G 1010 BRN 3.00 ST2	
11	700-028-00	SEMS 6-32X1/4 PHP BLKZC	
1	700-095-00	SCR PHP NYL 6-32 1/4	
2	705-001-00	KEPNUT 6-32	
3	740-001-00	TYRAP 3-1/4L	
2	740-002-00	TYRAP MOUNT .75 X .75	
AR	740-007-01	GROMMET STRIP MEDIUM	
1	550-251-00	METER BRIDGE	
16	704-001-02	PEMNUT 6-32 .054 STL	
5	704-043-08	STDF SNAP .156DIA X .875	
1	706-047-12	STDF BL 6-32X.875 STL PEM	
1	550-253-00	SIDE PANEL LEFT	
6	704-001-02	PEMNUT 6-32 .054 STL	
1	550-254-00	SIDE PANEL RIGHT	
5	704-001-02	PEMNUT 6-32 .054 STL	
2	706-036-02	STDF 6-32X.250L STL PEM	
1	550-292-00	BRKT ANALOG SHIELD	
2	704-001-00	PEMNUT 6-32 .030 STL	
1	550-379-00	PNT BOTTOM COVER	
1	550-388-00	TOP PANEL	
10	704-001-01	PEMNUT 6-32 .038 STL	
3	706-047-10	STDF BL 6-32X.750 STL PEM	



MACKIE. HUI SERVICE MANUAL

QTY	PART NO.	DESCRIPTION
1	551-041-00	EXTR PNT MTR BRIDGE
1	552-017-00	JOG WHEEL
44	700-011-00	MCH 4-40X1/4 BTNSKT BLKOX
16	700-011-01	MCH 4-40X3/16 BTNSK BLKOX
46	700-028-00	SEMS 6-32X1/4 PHP BLKZC
22	700-045-04	SEMS 10-32X3/8 PHP BLKZC
6	700-055-00	MCH 4-24X3/8 PHP BLK HILO
1	700-082-00	SET 6-32X1/8 CUP ALLOY
3	701-005-00	SM A-AB 6X1/4 PHP BLKZC
4	701-006-03	SM B 8X1/2 PHP ZC
18	705-003-00	NUT (SPLD W/JACK)
4	705-015-00	NUT SLOT NCKL
3	705-021-00	NUT CAP 1/2 DIA OD STLZC
4	706-017-00	STDF 4-40X.25 JACKSCREW
9	706-064-00	STDF NYL .25L M/F 4-40
18	710-002-00	WASHER (SPLD WITH JACK)
17	710-008-00	WASH SPLTLCK NO.4
4	710-019-00	WASH FIBRE BLK
1	710-029-00	WASH FELT .063X1.25X.5
1	740-002-00	TYRAP MOUNT .75 X .75
1	740-003-00	TYRAP 8IN BLK
4	750-004-00	FOOT #10 BLK 1 X .562
3	760-007-00	BTN 10MM SMALL BLK
1	760-073-00	END CAP LEFT
1	760-074-00	END CAP RIGHT
1	760-075-00	PNT ARMREST
1	760-076-00	JOG RING
4	760-081-00	KNOB TRIM W/PNTR
1	760-091-00	KNOB MASTER VOLUME
8	760-092-00	KNOB FADER METALIZED
1	760-100-00	BTN 10.5 X 8.8MM BLK
1	780-036-00	LENS MTR BRIDGE
1	780-037-00	LENS 5X7 DOT MATRIX DISPL
1	780-038-00	LENS SEGMENTED DISPL
1	780-039-00	LENS DISPLAY
1	780-113-00	FILTER VFD MTR BRIDGE
1	790-002-00	BAG POLY 12 X 18 2MIL
1	790-011-00	BAG POLY 20 X 7 X 30 4MIL
1	800-050-00	BOX ULTRAMIX PRO (M-434)
1	800-090-00	BOX
1	800-091-00	SLEEVE
1	810-078-00	FOAM LEFT
1	810-079-00	FOAM RIGHT
1	810-066-00	INSERT TRAY
1	840-100-00	LOGO NAMEPLATE - MOLDED

Parts Numbering guide

040-	Cables
055-	Finished PCB Assy
100-	Pots and resistors
200-	Capacitors
300-	Semiconductors
400-	Jacks/Connectors
500-	Switches
510-	Fuses
550-	Chassis Metalwork
600-	Transformers
601-	Inductors
610-	Wires and Cables
640-	AC line cords
700-	Hardware
760-	Knobs/Plastic
770-	Fans
790-	Misc./Packing
800-	Printed Material
860-	EPROM

CONTROL SURFACE PCB ASSY 055-102-01

Qty	Part #	Description	Reference Designator
2	040-156-00	RIB CBL ASSY, 28AWG 40C 2.75"	J3-4
13	130-045-00	POT 12MM ENDLESS ROT 50KG	R61-64 R86 R109 R114-115 R122-126
5	130-051-02	POT 9MM HORIZ 25MM 10KB	R112 R166-169
16	140-033-00	RESISTOR TF SMT .1W 22 5%	R6 R8 R10 R12 R14 R16 R18 R20 R60 R117 R119 R121 R129 R131 R133 R135
12	140-037-00	RESISTOR TF SMT .1W 33 5%	R22 R24 R58 R137 R139 R141 R143 R145 R147 R149 R151 R163
3	140-042-00	RESISTOR TF SMT .1W 51 5%	R26 R97-98
44	140-049-00	RESISTOR TF SMT .1W 100 5%	R25 R27-56 R65-77
28	140-065-00	RESISTOR TF SMT .1W 470 5%	R3 R7 R9 R11 R13 R15 R17 R19 R21 R23 R57 R59 R108 R116 R118 R120 R128 R130 R132 R134 R136 R138 R140 R142 R144 R146 R148 R150
1	140-073-00	RESISTOR TF SMT .1W 1K0 5%	R1
1	140-074-00	RESISTOR TF SMT .1W 1K1 5%	R153
2	140-080-00	RESISTOR TF SMT .1W 2K 5%	R156-157
2	140-083-00	RESISTOR TF SMT .1W 2K7 5%	R113 R127
2	140-084-00	RESISTOR TF SMT .1W 3K0 5%	R2 R5
1	140-087-00	RESISTOR TF SMT .1W 3K9 5%	R4
18	140-089-00	RESISTOR TF SMT .1W 4K7 5%	R78-85 R87-96
2	140-097-00	RESISTOR TF SMT .1W 10K 5%	R155 R158
4	140-104-00	RESISTOR CF .1W 20K 5%	R111 R159-161
26	140-114-00	RESISTOR TF SMT .1W 47K 5%	R164-165 R170-192 R194
2	140-117-00	RESISTOR TF SMT .1W 62K 5%	R152 R154
2	145-201-00	RESISTOR MF SMT .1W 121 1%	R110 R162
1	145-239-00	RESISTOR MF SMT .1W 301 1%	R100
1	145-285-00	RESISTOR MF SMT .1W 909 1%	R99
4	212-001-00	CAP CERAMIC SMT .01/50V 10%	C16 C66-68
3	212-003-00	CAP CERAMIC SMT 100PF/50V 5%	C31 C53 C69
1	212-007-00	CAP CERAMIC SMT .047/50V 20%	C61
80	212-010-00	CAP CERAMIC SMT .1UF/25V +80/-20%	C1-15 C17-18 C20-29 C32-38 C40 C42 C44 C46-52 C62-63 C71-78 C83-84 C87-97 C99-111
9	220-002-02	CAP LYTIC RAD TR 47UF/25V 20%	C19 C30 C39 C41 C43 C45 C64-65 C70
184	300-003-00	DIODE SIGNAL SMD DL4148	D10-13 D178 D205 D263-435 D437-441
1	304-006-00	DIODE LED T1-3/4 RED	D193
12	304-026-00	LED ARRAY V-POT	U18-29
3	304-027-02	LED T1, T&R W/SPACER RED	D217 D223-224
8	304-035-00	DISPLAY, 7 SEG 1DIG SUPR RED	D18 D34-40
24	304-040-02	LED, T1 TRANS W/TIE RED	D50-57 D82-89 D97 D185 D191 D197-198 D200 D203-204
86	304-042-02	LED, T1TRANS W/TIE YELLOW	D19-21 D30-33 D41 D66-73 D90-92 D94-96 D98-103 D106-109 D171-175 D182-183 D186-190 D192 D194 D196 D209 D216 D218-222 D225-256
9	304-045-00	DISPLAY, 5X7X4 CHAR DLG1414	D1-9
33	304-055-02	LED, T1, TRANS W/TIE HI GRN	D58-65 D74-81 D93 D176-177 D179-180 D184 D195 D199 D206-208 D257-262
9	304-057-00	LED, TRI-CLR, SUP/HI T1TRANS	D42-48 D181 D202
1	304-062-00	LED, T1FLNGLSS HI GRN	D214 (PLAY)
1	304-067-00	LED, T1TRANS FLNGLSS RED	D215 (RECORD)
4	304-069-00	LED, T1TRANS FLNGLSS YELLOW	D210-D213
28	311-001-00	X-SISTOR NPN SMD IMBT4401	Q32-39 Q57-61 Q67-69 Q73-84

MACKIE. HUI SERVICE MANUAL

Control surface continued

Qty	Part #	Description		Ref Designator
44	311-002-00	X-SISTOR PNP SMD	IMBT4403	Q1-31 Q40-52
18	320-012-00	I.C. LINEAR SMD	NJM4560M	U7-11 U40-52
1	321-008-00	I.C. ADJ POS 3 TERM VOLTAGE REG	LM317T	U39
4	325-003-03	IC, ANALOG MUX, 8 CHANNEL SMD	4051B	U3-6
5	325-006-03	IC, DCDR/DEMUX SMD	74HC138	U1 U12-13 U30-31
1	325-019-03	IC, QUAD, NAND, SMD	74HC00	U35
1	325-027-03	IC, SMD, DUAL D F/F	74HC74A	U34
4	325-029-03	IC, OCTAL BUFFER/LINE DRIVER	74HC244	U14-17
2	325-031-03	IC, CMOS UP/DOWN COUNTER SMD	74HC191	U32-33
1	400-195-00	CONNECTOR 5 PIN .100 X 1 STR SHRD		J5
16	400-203-00	SOCKET, HDR, 5P, .100 X 1 STR LOW PROFILE		Z194-209
18	400-212-00	SOCKET, HEADER, 6 PIN		Z228-245
1	400-224-00	CONNECTOR STR 8P .156 X 1, LOCKING KEYED		J2
1	400-238-00	HEADER .100 X 3 LOCKING		J8
1	450-102-00	PCB, HUI CONTROL SURFACE		Z193
1	480-001-00	MICROPHONE ELEMENT		M1
30	500-028-00	SWITCH, MOM SPST TACTILE PCMT		SW90-94 SW98-102 SW123-140 SW183 SW185
151	500-033-02	SWITCH, TACT 6MM SQR 260GF SPST		SW1-89 SW95-96 SW103-122 SW141-175 SW177-181
1	500-035-00	SWITCH, MOM SPST TACTILE PCMT 12MM		SW97
1	550-293-00	BRACKET, KEYPAD		Z100
16	601-004-00	FERRITE BEAD SMB	MLB40-5	L1-16
4	700-011-01	SCREW, BLK 4-40 X .188		Z101 Z125-127
33	706-033-01	STANDOFF, SWAGE, 4-40 X .542L		Z156-188
4	706-033-05	STANDOFF, SWAGE, 4-40 X .312L		Z96-99
6	706-052-00	SPACER, LED, .125		Z246-251
8	706-053-00	SPACER, PVC .210 TRI-LED		Z189-192 Z210-213
1	706-054-00	SPACER, PVC .350 TRI-LED		Z214
5	706-064-00	NYLON STANDOFF (ADD TO BRASS STANDOFFS WHICH SUPPORT BRAIN BOARD)		
13	760-063-00	KNOB, VPOT		Z140-151
12	760-064-00	LENS, DISPLAY VPOT		Z128-139
1	760-068-01	BUTTON, TRANSPORT REWIND		Z253
1	760-068-02	BUTTON, TRANSPORT F FWD		Z152
1	760-068-03	BUTTON, TRANSPORT STOP		Z153
1	760-068-04	BUTTON, TRANSPORT PLAY		Z154
1	760-068-05	BUTTON, TRANSPORT RECORD		Z155
1	760-068-06	BUTTON, TRANSPORT TALKBACK		Z252
1	760-072-01	BUTTON, RECT ENTER		Z107
1	760-072-02	BUTTON, RECT 0		Z108
1	760-086-01	BUTTON, MODE		Z102
4	760-086-02	BUTTON, ARROW		Z103-106
1	760-095-01	BUTTON, SQ 1		Z109
1	760-095-02	BUTTON, SQ 2		Z110
1	760-095-03	BUTTON, SQ 3		Z112
1	760-095-04	BUTTON, SQ 4		Z111
1	760-095-05	BUTTON, SQ 5		Z113
2	760-095-06	BUTTON, SQ 6 OR 9		Z114 Z117
1	760-095-07	BUTTON, SQ 7		Z115
1	760-095-08	BUTTON, SQ 8		Z116
1	760-095-10	BUTTON, SQ DECIMAL .		Z118
1	760-095-11	BUTTON, SQ PLUS +		Z119
1	760-095-12	BUTTON, SQ MINUS -		Z120
1	760-095-13	BUTTON, SQ ASTERISK *		Z121
1	760-095-14	BUTTON, SQ SLASH /		Z122
1	760-095-15	BUTTON, SQ EQUALS =		Z123
1	760-095-16	BUTTON, SQ CLEAR CLR		Z124
72	760-104-00	BTN HINGE SMALL REAN		Z24-95

Control surface continued

Qty	Part #	Description	Ref Designator
8	760-104-01	BTN HINGE SMALL REAN "REC/RDY"	B96-103
8	760-104-02	BTN HINGE SMALL REAN "INSERT"	B104-111
8	760-104-03	BTN HINGE SMALL REAN "V-SEL"	B112-119
23	760-105-00	BTN HINGE LARGE REAN	Z1-23
8	760-105-01	BTN HINGE LARGE REAN "AUTO"	B120-127
8	760-105-02	BTN HINGE LARGE REAN "SOLO"	B128-135
8	760-105-03	BTN HINGE LARGE REAN "MUTE"	B136-140 B142-143 B244
8	760-105-04	BTN HINGE LARGE REAN "SELECT"	B144-151

NOTE: THE TOP PANEL 550-388-00 CAN ONLY BE USED WITH THE LARGE BUTTONS 760-105-0x AND WITH THE SMALL BUTTONS 760-104-0x.

THE OLD TOP PANEL 550-250-00 WAS ONLY USED WITH THE OLD LARGE BUTTONS 760-067-0x AND WITH THE OLD SMALL BUTTONS 760-066-0x.

FADER PCB ASSY 055-216-00 REV A

Qty	Part #	Description	Reference Designator
1	040-160-00	CABLE ASSY	J4
1	040-164-00	CABLE ASSY	J2
8	040-167-00	CABLE ASSY, SERVO TO FADER	Z6-13
8	130-041-00	FADER MTRIZED 100MM MONO 10KB	R9-16
8	130-071-00	RESISTOR POT TRIM VERT 10K	R43 R46 R51 R54 R59 R62 R67 R70
8	140-089-00	RESISTOR TF SMT .1W 4K7 5%	R55 R63 R72 R75 R78 R81 R84 R87
8	140-124-00	RESISTOR TF SMT .1W 120K 5%	R42 R45 R50 R53 R58 R61 R66 R69
3	145-000-00	RESISTOR TF SMT .1W 0.0 5%	R92-94
1	145-229-00	RESISTOR MF SMT .1W 237 1%	R89
1	145-289-00	RESISTOR MF SMT .1W 1K00 1%	R91
1	145-297-00	RESISTOR MF SMT .1W 1K21 1%	R90
8	145-318-00	RESISTOR MF SMT .1W 2K00 1%	R1 R5 R17 R21 R25 R29 R33 R37
8	145-389-00	RESISTOR MF SMT .1W 10K0 1%	R48 R64 R73 R76 R79 R82 R85 R88
8	145-393-00	RESISTOR MF SMT .1W 11K0 1%	R41 R44 R49 R52 R57 R60 R65 R68
8	145-418-00	RESISTOR MF SMT .1W 20K0 1%	R47 R56 R71 R74 R77 R80 R83 R86
8	145-456-00	RESISTOR MF SMT .1W 49K9 1%	R2 R6 R18 R22 R26 R30 R34 R38
8	145-547-00	RESISTOR MF SMT .1W 442K 1%	R3 R7 R19 R23 R27 R31 R35 R39
8	145-581-00	RESISTOR MF SMT .1W 1M0 1%	R4 R8 R20 R24 R28 R32 R36 R40
20	212-001-00	CAP CERAMIC SMT .01/50V 10%	C1 C3 C5-6 C8 C10 C12 C14 C16 C20 C25 C28-30 C33-34 C37-38 C41-42
8	212-005-00	CAP CERAMIC SMT 20PF/50V 5%	C2 C4 C7 C9 C11 C13 C15 C17
23	212-010-00	CAP CERAMIC SMT .1UF/25V +80/-20%	C18-19 C21 C26-27 C31-32 C35-36 C39-40 C43 C45 C50 C55 C60 C78-84
4	212-024-00	CAP CER Y5V SMT 1UF /25V +80/-20%	C69-72
32	212-025-00	CAP CER SMT X7R .1UF/25V 10%	C22 C24 C46 C48 C51 C53 C56 C58 C61-68 C73-77 C85-95
8	224-018-00	CAP POLY FILM SMT 100PF/50V 2%	C23 C44 C47 C49 C52 C54 C57 C59
32	300-003-00	DIODE SIGNAL SMD DL4148	D1-20 D23-26 D29-32 D35-38
8	302-015-02	DUAL ZENER DIODE	ADD FROM FADER WIPERS TO FADER FRAME POSITIONING PINS
5	320-012-00	I.C. LINEAR SMD NJM4560M	U5-8 U17
4	323-010-00	I.C. LINEAR SMD MAX942	U13-16
8	325-032-03	IC, HEX, INV, SMD MC14069	U1-4 U9-12
1	450-216-00	PCB, HUI FADER	Z1
9	601-004-00	FERRITE BEAD SMB 150 MLB40-5	FB1-9
4	706-033-05	STANDOFF, BRASS	
4	706-064-00	NYLON INSULATED STANDOFF	(USE WITH BRASS STANDOFF)

METER PCB ASSY 055-104-00 REV A

Qty	Part #	Description	Reference Designator
12	140-037-00	RESISTOR TF SMT .1W 33 5%	R18 R20 R22 R24 R26 R28 R30 R32 R34 R36 R38 R40
28	140-065-00	RESISTOR TF SMT .1W 470 5%	R1-17 R19 R21 R23 R25 R27 R29 R31 R33 R35 R37 R39
3	212-017-00	CAP CERAMIC SMT .1UF/25V 10%	C1-3
1	220-019-00	CAP LYTIC RAD KS TR 47UF/16V 10%	C4
32	300-003-00	DIODE SIGNAL SMD	DL4148 D1-32
16	304-025-00	LED ARRAY, 12 ELEMENT	LED1-16
12	311-001-00	X-SISTOR NPN SMD IMBT4401	Q17-28
16	311-002-00	X-SISTOR PNP SMD IMBT4403	Q1-16
2	325-006-03	IC, DCDR/DEMUX SMD 74HC138	U1-2
1	400-147-00	CONNECTOR STR LCK SHRD 26P .100 X 2	J1
1	450-104-00	PCB, HUI METER	Z1

Parts Numbering guide

- 040- Cables
- 055- Finished PCB Assy
- 100- Pots and resistors
- 200- Capacitors
- 300- Semiconductors
- 400- Jacks/Connectors
- 500- Switches
- 510- Fuses
- 550- Chassis Metalwork
- 600- Transformers
- 601- Inductors
- 610- Wires and Cables
- 640- AC line cords
- 700- Hardware
- 760- Knobs/Plastic
- 770- Fans
- 790- Misc./Packing
- 800- Printed Material
- 860- EPROM

DCA PCB ASSY 055-105-00 REV B

Qty	Part #	Description	Reference Designator
1	040-175-00	CABLE, TRANS 40PIN 28 GA 2"	J5
1	040-186-00	CABLE TRANS 10 PIN 28GA 5"	J4
4	100-027-00	RESISTOR CF .125W 120 5%	R230-233
3	140-025-00	RESISTOR TF SMT .1W 10 5%	R207-208 R215
7	140-051-00	RESISTOR TF SMT .1W 120 5%	R1-2 R53 R211-214
2	140-070-00	RESISTOR TF SMT .1W 750 5%	R209-210
1	140-073-00	RESISTOR TF SMT .1W 1K0 5%	R25
6	140-085-00	RESISTOR TF SMT .1W 3K3 5%	R130-131 R190-191 R285-286
2	140-089-00	RESISTOR TF SMT .1W 4K7 5%	R8 R229
17	140-090-00	RESISTOR TF SMT .1W 5K1 5%	R16 R22 R27 R30 R32 R35 R37 R40 R42 R45 R50 R58 R60 R216-217 R249-250
66	140-097-00	RESISTOR TF SMT .1W 10K 5%	R7 R9-15 R17-20 R23-24 R26 R28 R31 R33 R36 R38 R41 R43 R46-47 R49 R51 R59 R81-82 R120-129 R180-189 R234-239 R253 R275-284
2	140-101-00	RESISTOR TF SMT .1W 15K 5%	R226-227
17	140-104-00	RESISTOR TF SMT .1W 20K 5%	R3 R6 R80 R114-115 R140-141 R240-245 R251-252 R269-270
3	140-114-00	RESISTOR TF SMT .1W 47K 5%	R4 R200 R287
12	140-123-00	RESISTOR TF SMT .1W 100K 5%	R136-139 R196-199 R222-225
24	140-140-00	RESISTOR TF SMT .1W 510K 5%	R5 R21 R29 R34 R39 R44 R52 R147-148 R201-206 R246-248 R288-293
12	145-201-00	RESISTOR MF SMT .1W 121 1%	R132-135 R192-195 R218-221
6	145-343-00	RESISTOR MF SMT .1W 3K32 1%	R116-117 R142-143 R271-272
17	212-003-00	CAP CERAMIC SMT 100PF/50V 5%	C21 C26 C28 C33 C36 C38 C43 C45 C48 C50 C55 C57 C62 C65 C67 C214-215 C60-61 C92 C109-110 C127 C136-141 C153 C216 C243-244
16	212-009-00	CAP CERAMIC SMT 47PF/50V 5%	C153 C216 C243-244
103	212-010-00	CAP CERAMIC SMT .1UF/25V +80/-20%	C1-20 C24-25 C31-32 C41-42 C53-54 C69-75 C77-83 C115-120 C158-165 C168 C170-171 C176-180 C182-184 C186-187 C190-193 C198-199 C202 C204-208 C211-212 C217-219 C221 C245-252 C255 C257-263
6	212-019-00	CAP CERAMIC SMT 150PF/50V 5%	C105-106 C123-124 C239-240
68	220-002-02	CAP LYTIC RAD TR 47UF/25V 10%	C22-23 C27 C30 C34-35 C37 C39-40 C44 C46-47 C49 C51-52 C56 C59 C63-64 C66 C76 C84-91 C93-104 C111-114 C121-122 C128-135 C154-157 C172-175 C181 C209 C220 C237-238
2	220-011-02	CAP LYTIC RAD TR 100UF/25V 10%	C210 C213
9	220-027-02	CAP LYTIC RAD TR 10UF/50V 10%	C166-167 C169 C200-201 C203 C253-254 C256
2	300-003-00	DIODE SIGNAL SMD DL4148	D1-2
2	301-004-00	DIODE POWER SMD DL4002	D11-12
5	320-006-00	I.C. LINEAR SMD NJM2068	U2 U7 U29 U33 U46
25	320-012-00	I.C. LINEAR SMD NJM4560M	U1 U6 U8 U10-14 U17 U30-31 U38-44 U47-51 U59-60
1	321-008-00	I.C. ADJ POS 3 TERM LM317T	U56 (VOLTAGE REGULATOR)
1	321-009-00	I.C. ADJ NEG 3 TERM LM337T	U55 (VOLTAGE REGULATOR)
1	325-007-03	IC, HEX, SCH TRIGGER, INV, SMD 74HC14	U66
3	325-012-03	IC, SMD, 8 BIT SHIFT REGISTER W/ OUTPUT LATCHES 74HC595	U52-54
1	325-018-03	IC, ANALOG SWITCH DG213	U9
13	325-018-03	IC, ANALOG SWITCH DG213	U3-5 U9 U23-28 U34-36
3	329-019-03	IC, DGTL ATTENUATOR CS3310	U22 U32 U64
1	400-061-00	HDR 2P .1X1 STR LOCK	J3
1	400-221-00	HDR 7P .156 LOCK KEY PIN6	J1
1	450-105-00	PCB, HUI DCA	Z5
2	410-005-00	Insulator, Sil-Pad, TO-220	NOTE: USE UNDER U55 AND U56

BRAIN PCB ASSY 055-106-00 REV B

Qty	Part #	Description	Reference Designator
27	E1-18 E23-31		
9	E19-22 Z1-5		
1	140-037-00	RESISTOR TF SMT .1W 33 5%	R15
6	140-073-00	RESISTOR TF SMT .1W 1K0 5%	R3 R16-20
5	140-074-00	RESISTOR TF SMT .1W 1K1 5%	R8-12
2	140-077-00	RESISTOR TF SMT .1W 1K5 5%	R1-2
1	140-095-00	RESISTOR TF SMT .1W 8K2 5%	R4
4	140-097-00	RESISTOR TF SMT .1W 10K 5%	R5-7 R14
1	145-162-00	RESISTOR MF SMT .1W 47R5 1%	R13
3	212-003-00	CAP CERAMIC SMT 100PF/50V 5%	C29 C32 C34
1	212-009-00	CAP CERAMIC SMT 47PF/50V 5%	C158
7	212-010-00	CAP CERAMIC SMT .1UF/25V +80/-20%	C5 C154-157 C159-160
2	212-015-00	CAP CERAMIC SMT 30PF/50V 5%	C20-21
34	212-017-00	CAP CERAMIC SMT .1UF/25V 10%	C1 C3 C6 C9 C11-12 C15 C17-19 C23-27 C30 C35-50 C52 C76
1	212-025-00	CAP CERAMIC SMT X7R .1UF/25V 10%	C2
6	220-002-02	CAP LYTIC RAD TAPE 47UF/25V 20%	C7-8 C10 C13-14 C51
1	220-011-02	CAP LYTIC RAD T&R 100UF/25V 20%	C4
4	220-027-02	CAP LYTIC RAD TAPE 10UF/50V 20%	C22 C28 C31 C33
1	315-003-00	CRYSTAL, 4.9152MHZ	Y1
1	315-007-00	CRYSTAL, 24MHZ	Y2
3	325-004-03	IC, QUAD, NOR, SMD 74HC02	U13-14 U16
2	325-006-03	IC, DCDR/DEMUX SMD 74HC138	U3-4
9	325-009-03	IC, OCTAL, D-TYP, TRANS LATCH, 74HC573	U9 U29-36
1	325-016-03	IC, DUAL 4-BIT BINARY COUNTER 74HC393	U2
1	325-020-03	IC, HEX, INV, SMD 74HC04	U1
5	325-029-03	IC, OCTAL BUFFER/LINE DRIVER 74HC244	U24-28
2	325-034-03	IC, QUAD, OR, SMD 74HC32	U17-18
1	325-053-03	IC, SMD, SCH TRIGGER HEX INV. 74AC14	U11
1	325-054-03	IC, SMD, OCTAL, D-TYP, TRANS 74AC573	U8 (LATCH)
2	329-001-00	IC, A/D CONVERTER, 8-BIT ADC0804	U20-21
1	329-005-03	IC, SRAM, 32K X 8-BIT 62256	U10
2	329-007-00	IC, ACIA 6850	U22-23
1	329-010-03	IC HIGH SPEED/LOW POWER 80C320	U7 (MICROPROCESSOR SMD)
1	329-013-03	IC, 64K BIT SERIAL EPROM 24C65	U6
1	329-020-00	IC, A/D CONVERTER, 10-BIT ADC1001	U19
1	400-078-00	HDR 10P .1X2 STR LCK SHRD	J2
1	400-079-00	HDR 14P .1X2 STR LCK SHRD	J5
1	400-152-00	HDR 34P .1X2 STR LCK SHRD	J10
1	400-185-00	HDR 26P .1X2 STR SHRD	J6
2	400-186-00	HDR 40P .1X2 STR SHRD	J3-4
1	400-190-00	HDR 16P .1X2 STR SHRD	J9
1	400-221-00	HDR 7P .156 LOCK KEY PIN6	J7
1	401-001-28	SOCKET, IC 28 PIN	Z9
1	450-106-00	PCB, HUI BRAIN	Z8
1	500-029-02	SWITCH MOM. TACTILE T&R SPST	SW1
10	601-004-00	FERRITE BEAD SMB MLB40-5	FB1-10

POWER SUPPLY PCB ASSY 055-207-00 REV A

Qty	Part #	Description	Ref Designator
1	100-097-00	RESISTOR CF .125W 100K 5%	R5
2	105-201-00	RESISTOR MF .125W 121 1%	R4 R10
4	105-335-00	RESISTOR MF .125W 2K74 1%	R1-3 R9
1	110-001-00	RESISTOR CF .25W 10 5%	R8
1	110-049-00	RESISTOR CF .25W 1K 5%	R14
1	110-071-00	RESISTOR CF .25W 8K2 5%	R6
1	110-080-00	RESISTOR CF .25W 20K 5%	R7
2	125-027-00	RESISTOR CF 5W 30 5%	R15-16 (5 WATT)
4	200-019-02	CAPACITOR MYLARTAPE .1UF/63V 10%	C10-13
2	200-023-00	CAPACITOR, POLY BOX .001UF/250V 20%	C16 C18
1	200-024-00	CAPACITOR, POLY BOX .01UF/250V 20%	C17
2	211-009-00	CAPACITOR CERAMIC AXIAL .1UF/50V 20%	C14-15
2	220-002-02	CAPACITOR LYTIC RADIAL TAPE 47UF/25V 20%	C5-6
2	220-003-02	CAPACITOR LYTIC RADIAL TAPE 47UF/50V 20%	C8-9
1	220-007-00	CAPACITOR LYTIC RADIAL 100UF/100V 20%	C7
2	220-028-00	CAPACITOR LYTIC RADIAL 4,700UF/35V 20%	C1-2
2	220-031-02	CAPACITOR LYTIC RADIAL 10UF/50V 20%	C3-4
12	301-001-00	DIODE POWER 1N4002	D1-10 D12-13
2	302-014-00	DIODE ZENER 1N4756	D11 (NOTE :TWO DIODES IN PARALLEL, IN THIS LOCATION)
2	310-006-00	TRANSISTOR POWER NPN TIP29C	Q1 Q3
1	321-008-00	I.C. ADJ POS 3 TERM V REG LM317T	U1
1	321-009-00	I.C. ADJ NEG 3 TERM VREG LM337T	U2
1	400-146-00	HDR 5P .156X1 STR LOCK	J1
8	400-173-00	CONN QUICK DISC .250	J8-15
1	400-219-00	HDR 5P .156X1 LOCK KEY PIN4	J3
3	400-221-00	HDR 7P .156X1 LOCK KEY PIN6	J2 J5 J7
1	400-224-00	HDR 8P .156X1 LOCK KEYED	J6
1	400-226-00	HDR6P .156X1 STR LOCK	J4
1	450-207-00	PCB, HUI POWER SUPPLY	Z1
2	700-011-00	SCREW, 4-40 X 1/4	Z4 Z9
2	705-005-00	NUT, LOCK 4-40	Z5 Z10
2	712-042-00	HEATSINK	Z2-3
1	730-001-00	GREASE, THERMAL	Z6
1	740-011-00	HEATSHRINK 2:1 .5" ID, .75" LONG	

NOTE: MAKE SURE METAL TAB OF Q1 IS COMPLETELY COVERED

ANALOG I/O PCB ASSY 055-156-00 REV A

Qty	Part #	Description	Reference Designator
6	110-001-00	RESISTOR CF .25W 10 5%	R5-6 R40-41 R75-76
3	110-027-00	RESISTOR CF .25W 120 5%	R7 R39 R42
6	115-373-00	RESISTOR MF .25W 6K81 1%	R2-3 R37-38 R72-73
3	130-033-02	RES POT 12MM HORIZ 10K	R9 R44 R79
6	140-065-00	RESISTOR TF SMT .1W 470 5%	R11-12 R46-47 R81-82
4	140-097-00	RESISTOR TF SMT .1W 10K 5%	R32-33 R67-68
5	140-104-00	RESISTOR TF SMT .1W 20K 5%	R8 R36 R43 R71 R78
3	140-139-00	RESISTOR TF SMT .1W 470K 5%	R1 R4 R74
3	145-051-00	RESISTOR MF .1W 3.32 1%	R10 R45 R80
6	145-201-00	RESISTOR MF .1W 121 1%	R29-30 R34 R64-65 R69
6	145-314-00	RESISTOR MF .1W 1K82 1%	R27-28 R62-63 R97-98
21	145-331-00	RESISTOR MF .1W 2K49 1%	R13-14 R21-25 R48-49 R56-60 R83-84 R91-95
12	145-361-00	RESISTOR MF .1W 5K11 1%	R15 R18-20 R50 R53-55 R85 R88-90
10	145-389-00	RESISTOR MF .1W 10K0 1%	R16-17 R31 R35 R51-52 R66 R70 R86-87
3	145-418-00	RESISTOR MF .1W 20K0 1%	R26 R61 R96
6	212-003-00	CAP CER SMT 100PF/50V 5%	C15-16 C40-41 C65-66
9	212-006-00	CAP CER SMT 470PF/50V 5%	C6-7 C9 C31-32 C34 C56-57 C59
8	212-009-00	CAP CER SMT 47PF/50V 5%	C11-12 C21 C36-37 C46 C61-62
20	212-010-00	CAP CER SMT .1UF/25V +80/-20%	C1 C17-18 C22-25 C42-43 C47-50 C67-73
3	212-016-00	CAP CER SMT 1000PF/50V 5%	C5 C30 C55
6	212-018-00	CAP CER SMT 10PF/50V 5%	C13-14 C38-39 C63-64
11	220-002-02	CAP LYTIC RAD 47UF/25V 10%	C8 C19-20 C26 C33 C44-45 C51 C54 C58 C75
9	220-003-02	CAP LYTIC RAD 47UF/50V 10%	C2-4 C27-29 C52-53 C74
3	220-030-00	CAP LYTIC RAD 1000UF/6.3V 10%	C10 C35 C60
3	300-003-00	DIODE SIGNAL DL4148	D6 D11 D16
6	302-015-02	DIODE, BI-DIR SA12CA	D1 D17-21
6	310-003-02	TRANS PNP 2SA1084	Q2-3 Q7-8 Q12-13
9	311-002-00	TRANS PNP SMD IMBT4403	Q4-6 Q9-11 Q14-16
5	320-006-00	I.C. LINEAR SMD NJM2068	U2-3 U5 U7-8
2	320-012-00	I.C. LINEAR SMD NJM4560M	U4 U6
1	400-186-00	HDR 40P .1X 2 STR SHRD	J21
18	400-214-00	JACK 1/4" PCMT 1MM WASH	J3-4 J6-7 J9-20 J22-23
3	400-223-00	XLR PCMT NEUTRIK-AP-SER	J2 J5 J8
1	450-156-00	PCB, HUI ANALOG I/O	Z100
3	500-018-00	SWITCH PUSH VERT PC MTG 2P2T	SW2-4
1	500-024-00	SWITCH SLIDE VERT PC MTG DPDT	SW5
3	601-002-00	INDUCTOR, AXIAL 4.7UH	FB2 FB5 FB8
44	601-004-00	FERRITE BEAD SMB MLB40-5 150 OHM	FB1 FB3-4 FB6-7 FB9-47
2	706-013-00	STANDOFF NO.4X.978L M/F	Z12-13
4	706-033-01	STANDOFF, SWAGE, #4 X .542L	Z1-4
3	760-003-00	BUTTON, SWITCH 9X5MM	Z14-16
3	760-028-00	BUTTON EXTENDER, LG CORE	Z11 Z101-102

NOTE: THE LAST TWO ITEMS MAY CHANGE TO PART 760-109-00, A 2-COLOR BUTTON WITH EXTENDER

SERVO PCB ASSY 055-158-00 REV A

Qty	Part #	Description		Reference Designator
8	100-056-00	RES CF .125W 2K	5%	R127 R163 R227 R263 R327 R363 R427 R463
8	100-059-00	RES CF .125W 2K7	5%	R121 R157 R221 R257 R321 R357 R421 R457
32	111-001-00	RES CF . 25W 1	5%	R137 R139 R144 R146 R173 R175 R178 R180 R237 R239 244 R246 R273 R275 R278 R280 R337 R339 R344 R34 R373 R375 R378 R380 R437 R439 R444 R446 R473 R475 R478 R480
1	130-015-00	RES POT TRIM 50KB	6MM	NOTE: NOT ALL WILL HAVE THIS INSTALLED.
8	130-053-00	POT TRIM HOZ 200		R113 R149 R213 R249 R313 R349 R413 R449
1	140-060-00	RES TF SM .1W 300	5%	R7
32	140-070-00	RES TF SM .1W 750	5%	R136 R140 R143 R147 R172 R176-177 R181 R236 R240 R243 R247 R272 R276-277 R281 R336 R340 R343 R347 R372 R376-377 R381 R436 R440 R443 R447 R472 R476-477 R481
1	140-072-00	RES TF SM .1W 910	5%	R8
24	140-089-00	RES TF SM .1W 4K7	5%	R128 R133-134 R164 R169-170 R228 R233-234 R264 R269-270 R328 R333-334 R364 R369-370 R428 R433-434 R464 R469-470
8	140-090-00	RES TF SM .1W 5K1	5%	R126 R162 R226 R262 R326 R362 R426 R462
50	140-097-00	RES TF SM .1W 10K	5%	R3-4 R118-119 R135 R138 R145 R148 R154-155 R171 R174 R179 R182 R218-219 R235 R238 R245 R248 R254-255 R271R274 R279 R282 R318-319 R335 R338 R345 R348 R354-355 R371 R374 R379 R382 R418-419 R435 R438 R445 R448 R454-455 R471 R474 R479 R482
17	140-104-00	RES TF SM .1W 20K	5%	R2 R130 R132 R166 R168 R230 R232 R266 R268 R330 R332 R366 R368 R430 R432 R466 R468
25	140-123-00	RES TF SM .1W 100K	5%	R5 R120 R123 R131 R156 R159 R167 R220 R223 R231 R256 R259 R267 R320 R323 R331 R356 R359 R367 R420 R423 R431 R456 R459 R467 R129 R165 R229 R265 R329 R365 R429 R465
8	140-139-00	RES TF SM .1W 470K	5%	
1	145-399-00	RES MF SM .1W 12K7	1%	R1
16	140-147-00	RES TF SM .1W 1M	5%	R6 R9-15 R124 R160 R224 R260 R324 R360 R424 R460
16	148-001-00	RES TF SM .1W 10K0	1%	R16 R122 R142 R158 R212 R222 R242 R258 R312 R322 R342 R358 R412 R422 R442 R458
48	212-001-00	CAP CER SMT .01UF/50V	10%	C111-116 C120-121 C124-127 C211-216 C220-221 C224-227 C311-316 C320-321 C324-327 C411-416 C420-421 C424-427
24	212-003-00	CAP CER SMT 100PF/50V	5%	C122-123 C150-153 C222-223 C250-253 C322-323 C350-353 C422-423 C450-451C453-454
25	212-010-00	CAP CER SMT .1UF/25V +80/- 20		C1 C5 C10-21 C23-24 C30-38
16	212-030-00	CAP CER X7R 1UF /16V	10%	C107-108 C118-119 C207-208 C218-219 C307-308 C318-319 C407-408 C418-419
9	220-002-02	CAP LYTIC RAD 47UF/25V	20%	C2-4 C9 C39-43
2	220-005-00	CAP LYTIC RAD 470UF/25V	20%	C6 C44
8	220-012-02	CAP LYTIC RAD 4.7UF/63V	20%	C7-8 C22 C25-29
56	300-003-00	DIODE SIGNAL SMD		DL4148 D107-120 D207-220 D307-320 D407-420
16	310-012-00	XSTOR POWER PNP MJE171		Q103 Q105 Q108 Q110 Q203 Q205 Q208 Q210 Q303 Q305 Q308 Q310 Q403 Q405 Q408 Q410
16	310-013-00	XSTOR POWER NPN MJE181		Q102 Q104 Q107 Q109 Q202 Q204 Q207 Q209 Q302 Q304 Q307 Q309 Q402 Q404 Q407 Q409

MACKIE. HUI SERVICE MANUAL

SERVO continued

Qty	Part #	Description	Reference Designator
8	311-004-00	XSTOR JFET SMD SST112	Q101 Q106 Q201 Q206 Q301 Q306 Q401 Q406
30	320-012-00	I.C. LINEAR SMD NJM4560M	U2 U5-9 U103-108 U203-208 U303-308 U403-408
1	321-008-00	I.C. ADJ POS 3 TERM V REG LM317T	U3
1	325-003-03	IC, ANALOG MUX, 8 CHANNEL SMD 4051	U4
1	329-032-03	IC, OCTAL 12-BIT DAC AD7568	U1
8	400-061-00	HDR 2P .1X1 STR LOCK	J101-102 J201-202 J301-302 J401-402
1	400-078-00	HDR 10P .1X2 STR LOCK SHRD	J3
1	400-152-00	HDR 34P .1X2 STR LOCK SHRD	J5
1	400-190-00	HDR 16P .1X2 STR SHRD	J4
1	400-219-00	HDR 5P .156 LOCK KEY PIN4	J2
1	400-221-00	HDR 7P .156 LOCK KEY PIN6	J1
1	450-158-00	PCB, HUI SERVO	Z101

NOTE : THE SILKSCREENING OF THE CIRCUIT BOARD FOR CAPACITOR C-41 IS INCORRECT ON SOME BOARDS. IF YOU EVER HAVE TO REPLACE C-41, MAKE A NOTE OF THE ALIGNMENT OF THE OLD CAP BEFORE REPLACING IT .

SOME BOARDS HAVE A 50K TRIM POT AROUND U3 TO CORRECT THERMAL DRIFT,
 PIN1 CONNECTS TO GROUND "D"
 PIN2 CONNECTS TO U3 PIN 1
 PIN3 CONNECTS TO U3 PIN 2
 THE ADJUSTMENT PROCEDURE FOR THIS POT IS ON PAGE 26 OF THE
 MAIN SECTION OF THIS MANUAL

Parts Numbering guide

040-	Cables
055-	Finished PCB Assy
100-	Pots and resistors
200-	Capacitors
300-	Semiconductors
400-	Jacks/Connectors
500-	Switches
510-	Fuses
550-	Chassis Metalwork
600-	Transformers
601-	Inductors
610-	Wires and Cables
640-	AC line cords
700-	Hardware
760-	Knobs/Plastic
770-	Fans
790-	Misc./Packing
800-	Printed Material
860-	EPROM

DIGITAL INPUT PCB ASSY 055-165-00 REV A

Qty	Part #	Description	Reference Designator
1	140-057-00	RESISTOR TF SMT .1W 220 5%	R7
1	140-065-00	RESISTOR TF SMT .1W 470 5%	R8
4	140-073-00	RESISTOR TF SMT .1W 1K0 5%	R1-2 R4-5
2	140-097-00	RESISTOR TF SMT .1W 10K 5%	R3 R6
4	212-010-00	CAP CER SMT Z5U SM .1UF/25V 20%	C1,C2,C3,C8
4	212-025-00	CAP CER SMT X7R SM .1UF/25V 10%	C4,C5,C6,C7
1	220-002-00	CAP LYTIC RADIAL 47UF/25V 20%	C9
1	300-003-00	DIODE SIGNAL SMD DL4148	D1
2	311-001-00	X-SISTOR NPN SMD IMBT4401	Q1-2
1	324-003-03	IC, CMOS LOW PWR DRVR MAX488	U2
1	324-004-03	IC, CMOS RS-232 MAX232	U3 DRIVERS/RECEIVERS SMT
1	329-008-00	IC, OPTO-ISOLATOR PC900	U1
1	400-115-00	CONNECTOR, DSUB, 9 PIN MALE	J4
2	400-166-00	CONNECTOR, STEREO, JACK 1/4"	J1-2 HORIZ SLIM
1	040-185-00	RIB CBL ASSY TRANS 28GA 14C 3.25"	J5
2	400-202-00	CONNECTOR, MINI DIN 4P	J6-7
1	400-204-00	CONN, DIN, 5P, RTA, PC, SHIELD	J3
1	450-165-00	PCB, HUI, DIGITAL INPUT	Z1
1	500-031-00	SWITCH 8PDT HORIZ PUSHBUTTON 8PDT	SW1
10	601-004-00	FERRITE BEAD SMB MLB40-5	FB1-10
1	712-020-00	BRACKET, ANGLE	Z2-3
2	712-021-01	RIVET	Z4-7

DIGITAL OUTPUT PCB ASSY 055-166-00 REV A

Qty	Part #	Description	Reference Designator
1	040-187-00	RIB 28GA 16C TRANS 4.5"	J8
2	140-057-00	RESISTOR TF SMT .1W 220 5%	R3-4
1	140-061-00	RESISTOR TF SMT .1W 330 5%	R9
2	140-073-00	RESISTOR TF SMT .1W 1K0 5%	R1-2
1	140-082-00	RESISTOR TF SMT .1W 2K4 5%	R6
1	140-083-00	RESISTOR TF SMT .1W 2K7 5%	R7
1	140-093-00	RESISTOR TF SMT .1W 6K8 5%	R8
1	140-106-00	RESISTOR TF SMT .1W 24K 5%	R5
8	212-010-00	CAP CER SMT Z5U .1UF/25V +80/-20	C1 C3 C5-8 C10-11
2	220-002-00	CAP, LYT, RAD 47UF/25V 20%	C2 C4
1	220-019-00	CAP LYTIC RAD KS 47UF/16V 20%	C9
3	301-004-00	DIODE POWER SMD DL4002	D1-3
1	310-007-00	XSTOR NPN 2N4401	Q3
2	311-001-00	XSTOR NPN SMD IMBT4401	Q1-2
2	325-019-03	IC, QUAD, NAND, SMD 74HC00	U2-3
1	325-020-03	IC, HEX, INV, SMD 74HC04	U1
1	400-115-00	DSUB, 9 PIN MALE RTA PCMNT	J6
2	400-166-00	CONNECTOR, STEREO, JACK 1/4"	J1-2
1	400-189-00	HDR 14P .1X 2 RTA SHRD	J7
2	400-202-00	CONNECTOR, MINI DIN 4P	J4-5
1	400-204-00	CONN, DIN, 5P, RTA, PC, SHIELD	J3
1	450-166-00	PCB, HUI, DIGITAL OUTPUT	Z1
1	480-014-00	SPEAKER, PC MT	S1
2	501-001-00	RELAY, SUBMINIATURE PCB	K1-2
4	601-004-00	FERRITE BEAD SMB MLB40-5	FB1-4
1	712-020-00	BRACKET, ANGLE	Z2-3
2	712-021-01	RIVET	Z4-7

ESD PCB ASSY 055-222-00 REV A

Qty	Part #	Description	Reference Designator
1	040-164-00	RIB 28GA 10C TRANS 3.75"	
8	100-073-00	RESISTOR CF SMT .125W 10K 5%	R1-R8
1	400-078-00	HDR 10P .1X2 STR LCK SHRD	

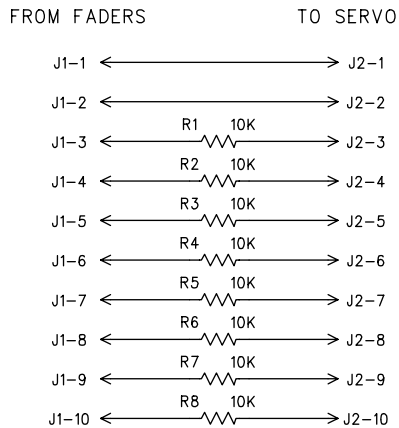

NOTE:

Not all of the HUI's will have this board. There is no need to install one if the HUI you are servicing does not have it.

Parts Numbering guide

- 040- Cables
- 055- Finished PCB Assy
- 100- Pots and resistors
- 200- Capacitors
- 300- Semiconductors
- 400- Jacks/Connectors
- 500- Switches
- 510- Fuses
- 550- Chassis Metalwork
- 600- Transformers
- 601- Inductors
- 610- Wires and Cables
- 640- AC line cords
- 700- Hardware
- 760- Knobs/Plastic
- 770- Fans
- 790- Misc./Packing
- 800- Printed Material
- 860- EPROM

MACKIE. HUI SERVICE MANUAL

PART#	DESCRIPTION	REV	QTY
090-068-00	HUI 120V	29	1
040-158-00	RIB 28GA 34C 2.75IN PLZD		1
040-165-00	RIB 18GA 7C .156 7.5IN	A	1
040-166-00	RIB 18GA 5C .156 8.0IN	A	1
040-168-00	RIB 18GA 7C .156 6.00IN	A	1
040-169-00	CBL ASSY 24GA 3/2C .1 17.	B	1
040-170-00	RIB 22GA 5C .100 2.00IN	A	1
040-171-00	RIB 18GA 8C .156 6.0IN	A	1
040-283-00	RIB 18GA 7C .156 4.5IN	A	1
055-102-02	PCB ASSY CNTRL SURF - HUI	D1	1
055-105-00	PCB ASSY DCA - HUI	2	1
055-106-00	PCB ASSY BRAIN - HUI	4	1
055-156-00	PCB ASSY ANALOG 1/O - HUI	2	1
055-158-00	PCB ASSY SERVO - HUI	A4	1
055-165-00	PCB ASSY DGTL INPUT - HUI	2	1
055-166-00	PCB ASSY DGTL OUTPUT HUI	2	1
055-216-00	PCB ASSY FADER - HUI	A2	1
080-033-00	SA PWR SPLY - HUI	A4	1
080-042-00	SA JOG SWITCH - HUI	A3	1
080-043-00	SA DISPLAY - HUI	A2	1
080-045-03	SA EPROM PRGMD V1.45 HUI	A	1
550-251-00	METER BRIDGE - HUI	C	1
550-253-00	SIDE PANEL LEFT - HUI	B	1
550-254-00	SIDE PANEL RIGHT - HUI	B	1
550-292-00	BRKT ANALOG SHIELD - HUI	A	1
550-379-00	PNT BOTTOM COVER - HUI	A	1
550-388-00	TOP PANEL - HUI	A	1
551-041-00	EXTR PNT MTR BR RIDGE HUI	A	1
552-017-00	JOG WHEEL - HUI	B	1
640-001-00	LC IEC SJT 10A/125V 6FT	C	1
700-011-00	MCH 4-40X1/4 BTNSKT BLKOX	A	44
700-011-01	MCH 4-40X3/16 BTNSK BLKOX	A	16
700-028-00	SEMS 6-32X1/4 PHP BLKZC	B	46
700-045-04	SEMS 10-32X3/8 PHP BLKZC	A	22
700-055-00	MCH 4-24X3/8 PHP BLK HILO	A	6
700-082-00	SET 6-32X1/8 CUP ALLOY	A	1
701-005-00	SM A-AB 6X1/4 PHP BLKZC	A	3
701-006-03	SM B 8X1/2 PHP ZC	A	4
705-003-00	NUT HEX-SPLD W/400-214-00	A	AR
705-015-00	NUT SLOT NCKL	A	4
705-021-00	NUT CAP 1/2 DIA OD STLZC	b	3
706-017-00	STDF 4-40X.25 JACKSCREW	A	4
710-002-00	WASHER-SPLD W/400-214-00	A	AR
710-008-00	WASH SPLTLCK NO.4	A	17
710-019-00	WASH FIBRE BLK	A	4
710-029-00	WASH FELT .063X1.25X.5	A	1
750-004-00	FOOT #10 BLK 1 X .562	A	4
760-007-00	BTN 10MM SMALL BLK		3
760-073-00	END CAP LEFT - HUI	B	1
760-074-00	END CAP RIGHT - HUI	B	1
760-075-00	PNT ARMREST - HUI	B	1
760-076-00	JOG RING - HUI	A	1
760-081-00	KNOB TRIM W/PNTR	A	4

PART#	DESCRIPTION	REV	QTY
760-091-00	KNOB MASTER VOLUME	1	1
760-092-00	KNOB FADER METALIZED	1	8
760-100-00	BTN 10.5 X 8.8MM BLK	A	1
780-036-00	LENS MTR BRIDGE HUI	B	1
780-037-00	LENS 5X7 DOT MATRIX DISPL	A	1
780-038-01	LENS SEGMENTED DISPL HUI	A	1
780-039-00	LENS DISPLAY - HUI	A	1
780-113-00	FILTER VFD MTR BRIDGE HUI	B	1
790-002-00	BAG POLY 12 X 18 2MIL	A	1
790-011-00	BAG POLY 20 X 7 X 30 4MIL	A	1
800-050-00	BOX ULTRAMIX PRO (M-434)		1
800-090-00	BOX - HUI		1
800-091-00	SLEEVE - HUI		1
810-066-00	INSERT TRAY -HUI		1
810-078-00	FOAM LEFT - HUI		1
810-079-00	FOAM RIGHT - HUI		1
820-069-03	REF GUIDE HUI		1