

SECTION 2A

CIRCUIT DESCRIPTION

2.1 GENERAL (Serial Number 4160 and Below)

The Moog Prodigy Synthesizer, Domestic Model 336A and Export Model 336BX, consists of a 32 note F to C keyboard, two voltage controlled oscillators, two envelope generators, one voltage controlled low pass filter, one voltage controlled amplifier and a regulated power supply. For ease of description, the circuits are broken down into the following major blocks:

Power Supply	Envelope Generators
Keyboard Circuit	Voltage Controlled Filter
Modulation Oscillator	Voltage Controlled Amplifier
Oscillators 1 and 2	

2.1.1 POWER SUPPLY

The power supply consists of a step-down transformer, full wave bridge rectifier, filter capacitors, and two 3-terminal voltage regulators.

Transformer T1, rectifiers CR3 through CR6, and filter capacitors C38 and C39 convert the 120 volts from the AC line to ± 23 volts unregulated. U24 and U25 are nonadjustable preset regulators that produce regulated +12 and -12 volts respectively. Capacitors C36 and C37 prevent the regulators from oscillating while capacitors C34 and C35 improve the regulator transient response.

The export version of the Prodigy has a 240 volt transformer with extra secondary fuses to comply with stringent IEC safety regulation.

2.1.2 KEYBOARD AND ASSOCIATED CIRCUITRY

The keyboard circuit consists of a 32-note F to C dual-contact keyboard, constant current source, sample-hold amplifier with linear glide and a summing amplifier. Integrated circuit U11B feeds a constant 0.84mA through 31 100 ohm resistors in the keyboard producing 1 volt per octave. The "Freq Scale" trim pot R178 adjusts this current for 1 volt per octave across the keyboard resistor string. When a key is depressed, two things occur: a voltage corresponding to the depressed note appears first at pin 5 of U12B and

then +12 volts appears on the trigger buss which activates the sample-hold circuit and the dual envelope generator.

Operational amplifier U12B, GLIDE control R79, integrated circuit U14B and operational amplifier U12A form a combination sample-hold amplifier and a linear glide circuit. As long as the trigger voltage remains on, the output of U12A will track the pitch voltage from the keyboard. When all keys are released, the trigger voltage disappears, U14B turns off and C21 and U12A "hold" the last pitch voltage. The pitch and trigger contacts on the keyboard are arranged so the trigger will disappear before the pitch to ensure that the sample-hold will remember the correct pitch. GLIDE control R79 and capacitor C21 form a lag circuit inside the sample-hold feedback loop which produces linear glide between notes. At low resistance values of R79, two successive notes played on the keyboard will appear as discrete pitch jumps, but as the value of R79 is increased, the pitch will glide between notes.

The output of U12A is routed to U11A, where it is summed with the pitch wheel voltage, the tune control and oscillator modulation voltage selected from OSCILLATOR MOD switch SW7. Diodes CR1 and CR2 provide a small electrical dead band in the pitch wheel to compensate for play in the wheel's mechanical detent. The inverted signal from U11A is routed to both oscillators.

2.1.3 MODULATION OSCILLATOR

The modulation oscillator is a standard single operational amplifier triangle and square wave generator followed by a waveform selector switch, buffer and the modulation wheel.

The voltage on capacitor C24 oscillates between the $\pm 1.5V$ trip point set by resistors R101 and R100, producing a 3 volt peak-to-peak triangle on capacitor C24 and a 24 volt peak-to-peak square wave on the output of U13A. The smaller the value of MOD RATE control R98, the higher the frequency of oscillation.

emitter of transistor Q40, which is called the sustain voltage. The voltage at this point varies between 0 and 8 volts depending on the setting of the SUSTAIN control R162. As long as any key on the keyboard is depressed, capacitor C44 will hold at the sustain voltage.

When all the keys on the keyboard are released, the trigger generator returns to normal and dual timer U23 is reset back to zero. What happens next depends on the setting of the FINAL DECAY RELEASE switch SW10. In the OFF position, capacitor C44 is discharged very quickly to ground through resistor R156. When switch SW10 is ON, capacitor C44 is discharged through LOUDNESS CONTOUR DECAY/RELEASE control R158 to ground. Therefore, the discharge rate is the same as the initial decay rate.

The output of the top envelope generator is routed to the VCA to control loudness. The bottom envelope generator is routed to the VCF to control cutoff frequency.

2.2.6 VOLTAGE CONTROLLED FILTER (VCF)

The Prodigy uses the patented Moog 24dB per octave low pass filter with exponential control of cutoff frequency. A positive feedback loop is provided which puts a variable height resonance peak at the cutoff frequency of the filter. The filter can also be used as a sine wave oscillator.

The outputs of both oscillators are summed and attenuated by resistors R104, R105 and R137 and then applied to the base of Q29. Transistors Q29 and Q30 convert the input signal into a differential signal current in the ladder. The collectors, capacitors and the next emitters form a 1-pole current-controlled low pass filter. The cutoff frequency of the filter is directly proportional to the standing current in each leg of the ladder. The four stages in the ladder add up to a four-pole filter.

The differential signal voltage is buffered by an ac differential Darlington stage consisting of transistors Q32, Q33, Q34 and Q35. The signal is routed to the VCA, U17 and to the emphasis amplifier U16B. This converts the differential voltage into a single ended output which is applied to the FILTER EMPHASIS control R136.

Since the total phase shift equals 180 degrees at the cutoff frequency of the filter and the feedback signal is injected into the minus input of the filter, we get positive feedback. This puts a resonance peak in the response of the filter at the cutoff frequency. The height of the peak depends on the setting of the FILTER EMPHASIS control R140. At full emphasis, the filter will oscillate, producing a sine wave. "Emphasis" trimpot R135 sets the oscillation threshold.

As previously stated, the cutoff frequency of the filter is controlled by the standing current in the filter. The standing current is generated by transistors Q37 and Q38, a poor man's exponential voltage to current converter. For every 18mV increase in base voltage on transistor Q37, the current through Q38 doubles, resulting in an exponential current response.

The control signals for cutoff frequency are generated in many circuits. The FILTER CUTOFF FREQUENCY control R141 allows manual setting of the cutoff frequency from the front panel. The FILTER KYBD TRACKING switch SW6 allows the filter to track the keyboard in one-half scale (2 octaves of keyboard movement per octave of filter movement) or full scaling with scale set by "Filter Scale" trimpot R152. The FILTER MOD switch SW8 routes the output of the modulation wheel to the filter. Lastly, the VCF envelope generator is routed through the FILTER CONTOUR AMOUNT control R150, allowing the envelope waveform to sweep the filter.

2.2.7 VOLTAGE CONTROLLED AMPLIFIER (VCA)

The VCA uses an operational transconductance amplifier as a control element. Integrated circuit U17 takes the differential signal voltage from the VCF and amplifies it. The gain of U17 is proportional to the current flowing into pin 5. This current is supplied by transistor Q39, which is controlled by the VCA envelope generator.

The amplified voltage appears across resistor R119, where it is buffered by integrated circuit U16A. The output of U16A is routed to the MASTER VOLUME control R122 and then to output jack J3. "VCA Balance" trimpot R120 compensates for the input offset of U17 to reduce control signal bleed-through.

This turns transistor Q14 on for 1 microsecond, discharging capacitor C8 to 6 volts. Transistor Q14 then turns off again, the process repeats, and a sawtooth waveform appears on the emitter Q15. Diode CR1 clamps the base to emitter junction of Q15 during reset to minimize the amplifier reset time.

Transistor Q15 also converts the sawtooth to a triangle wave. When the sawtooth is below 3 volts, Q15 acts as a simple inverter. But above 3 volts, Q15 saturates and therefore the collector follows the input voltage. This converts the sawtooth to a triangle wave. Integrated circuit U5B amplifies and offsets the output of transistor Q15 to produce a 6 volt triangle.

The sawtooth is converted to a 6 volt 10% duty cycle pulse by comparator U6B. All three waveforms are routed to OSC 1 WAVEFORM selector switch SW4 and the selected voltage is routed to OSC 1 LEVEL control R47.

There are a few adjustments in oscillator 1. "Osc 1 Scale" trimpot R7 sets the volts per octave and "Osc 1 Freq" trimpot R1 sets the reference frequency (transposes the keyboard). Since the exponential current source goes flat at higher currents, "Osc 1 Hi End" trimpot R42 compensates the oscillator to correct the tuning error resulting from this effect.

As previously stated, oscillator 2 is almost identical to oscillator 1 but differs in the following areas: OSC 2 INTERVAL control R21 varies the frequency of oscillator 2 \pm a fifth from oscillator 1; oscillator 2 is tuned an octave higher than oscillator 1; oscillator 2 can be synchronized to oscillator 1, and the pulse width is a 50% duty cycle square wave.

OSC 2 INTERVAL CONTROL R19 is connected to the base of Q7. Therefore, this control transposes oscillator 2 directly without affecting oscillator 1. Oscillator 2 uses a timing cap that is approximately one-half the value of oscillator 1. Therefore, oscillator 2 can be tuned an octave higher than oscillator 1.

An extra reset, FET Q13, is connected across capacitor C14 to provide OSCILLATOR SYNC with the gate of transistor Q13 connected through SYNC switch SW3. When switch SW3 is OFF, Q13 is turned

off and the PITCH WHEEL moves both oscillators. When switch SW3 is ON, Q13 is connected to reset comparator U6A. Oscillator 1's reset pulse will also reset oscillator 2 and therefore the fundamental frequency of oscillator 2 is locked to oscillator 1. The SYNC switch SW3 also disconnects the PITCH WHEEL from U11A and routes it directly to transistor Q7 of U3A. Therefore, the PITCH WHEEL shifts the upper harmonics of oscillator 2.

2.2.5 ENVELOPE GENERATORS

The Prodigy has two independent four-part envelope generators, one for the VCA and one for the VCF. Each envelope generator has three controls: ATTACK time (R155 and R166), INITIAL FINAL DECAY time (R158 and R169), and SUSTAIN level (R162 and R172). RELEASE switch SW10 is provided to activate the final decay mode. Since both envelope generators are identical, the operation of the one for the VCA will be the only one discussed.

The envelope generator is activated by a V-trigger from the keyboard. This V-trigger is routed to trigger generator Q18, Q19, Q42 and Q43. Q42 produces an S-trigger, Q43 a buffered V-trigger and C37 and R179 a 200 microsecond S-trigger pulse with every V-trigger from the keyboard. The first S-trigger from Q42 turns switch U18C off which removes the discharge path of capacitor C44.

The V-trigger from Q43 and the S-trigger pulse from U18C activates the dual timer U23. This puts -12 volts at pin 5 of U23 which is inverted by integrated circuit U18A. This grounds pin 3 of U18B which turns the P-channel FET on, charging capacitor C40 through the ATTACK time control R155 and resistor R157. The value of R155 sets the charging time of capacitor C44 and therefore the attack time. The voltage on capacitor C44 is buffered by integrated circuit U22A. When the voltage at the output of U22A reaches +8 volts, the dual timer changes from the ATTACK mode to the DECAY mode. Pin 5 of U23 drops to ground, which turns the P-channel of U18B off and the N-channel on. Capacitor C44 is discharged through resistor R157 and LOUDNESS CONTOUR DECAY RELEASE control R158. R158 sets the discharge rate and therefore the decay time. Capacitor C44 is discharged to the voltage on the

producing a 3 volt peak-to-peak triangle on capacitor C21 and a 24 volt peak-to-peak square wave on the output of U13A. The smaller the value of MOD RATE control R106, the higher the frequency of oscillation. Diode CR8 and resistors R110 and R111 produce a 0 to 3 volt square wave.

MOD SHAPE switch SW9 selects the triangle or the square, routes it to buffer U13B and then to MODULATION wheel R181. R181 has a special taper which allows the wiper to reach almost full value in 100 degrees of rotation. The output of the MODULATION wheel R181 is routed to switches SW7 OSCILLATOR MOD and SW8 FILTER MOD to select oscillator modulation and/or filter modulation.

2.2.4 OSCILLATORS 1 AND 2

The oscillators used in the Prodigy consist of a temperature regulated current source, a precision sawtooth oscillator, triangle converter and a pulse generator. Since oscillator 2 is almost identical to oscillator 1, oscillator 1 will be described fully with the minor differences in oscillator 2 noted later.

The linear voltage to exponential current converter consists of Q1, reference voltage source Q2 and U2A and temperature regulator Q3, U2B, Q6 and Q5.

The formula for the current through the collector of Q1 equals:

$$I_{CQ1} = I_{REF} \times e^{\frac{V_{in}}{VT}}$$

$$I_{CQ1} = \frac{IC03}{IC02} e^{\frac{V_{in}}{VT}}$$

Where:

T = absolute temperature in degrees Kelvin

q = 1.6×10^{-19} charge on an electron

K = 1.38×10^{-23} (Boltzmann's Constant)

I_{REF} = reference current through Q2

I_{CO} = reverse saturation current of the transistor

$$VT = \frac{KT}{q} = 28mV \text{ at room temperature}$$

$$V_{in} = (V_{BEQ2} - V_{BEQ3})$$

The reference current is maintained by U2A which senses the voltage drop across resistors R4 and R6 and pulls current out of the emitter of transistor Q2 to maintain this voltage drop at 12 volts. From the formula, the current through transistor Q1 is directly proportional to the reference current. OSCILLATOR 1 OCTAVE switch SW1 arranges the resistors R4 and R6 to provide exact octave changes in the reference current which causes octave changes in the current from transistor Q1.

For every 20mV increase in voltage on the base of transistor Q1 or for every 20mV decrease on the base of transistor Q2, the current through Q1 doubles. Resistors R9 and R5 and "Osc 1 Scale" trimpot R7 scale the input to the standard 1 volt per octave keyboard voltage. "Osc 1 Freq" trimpot R1 sets the oscillator frequency by offsetting the current source. Capacitor C1 prevents the reference current loop from self oscillating.

Since temperature changes affect the scale factor (volts per octave) and therefore keyboard tuning, transistors Q1 and Q2 are in a transistor array which is maintained at 55°C by a temperature regulating loop. The entire chip is heated by the power dissipated by transistor Q5. The more current pulled from Q5 by Q6, the higher the chip temperature. Transistor Q3 is an electronic thermometer with a -2mV per degree centigrade temperature co-efficient. U2B compares the chip temperature with the desired temperature set on "OSC 1 CHIP TEMP" trimpot R13. Operational amplifier U2B then adjusts the drive to Q6 to maintain the correct temperature.

The oscillator consists of voltage source U5A, timing capacitor C8, buffer U7, comparator U6A and electronic switch Q14. As stated before, the linear keyboard voltage produces a current through Q1 that varies at 1 volt per octave. This current charges capacitor C8, producing a downward linear ramp starting at 6 volts. Operational amplifier U7 and transistor Q15 form a voltage follower which tracks the voltage on capacitor C8. When the voltage at the emitter of transistor Q15 reaches zero volts, the output of U6A jumps to 6 volts for approximately 1 microsecond.

SECTION 2B

CIRCUIT DESCRIPTION

2.2 GENERAL (Serial Numbers Above 4160)

The Moog Prodigy Synthesizer, Domestic Model 336A and Export Model 336BX, consists of a 32 note F to C keyboard, two voltage controlled oscillators, two envelope generators, one voltage controlled low pass filter, one voltage controlled amplifier and a regulated power supply. For ease of description, the circuits are broken down into the following major blocks:

Power Supply	Envelope Generators
Keyboard Circuit	Voltage Controlled Filter
Modulation Oscillator	Voltage Controlled Amplifier
Oscillators 1 and 2	

2.2.1 POWER SUPPLY

The power supply consists of a step-down transformer, full wave bridge rectifier, filter capacitors, and two 3-terminal voltage regulators.

Transformer T1, rectifiers CR10 through CR13, and filter capacitors C42 and C43 convert the 120 volts from the AC line to ± 23 volts unregulated. U20 and U21 are nonadjustable preset regulators that produce regulated +12 and -12 volts respectively. Capacitors C40 and C41 prevent the regulators from oscillating while capacitors C38 and C39 improve the regulator transient response.

The export version of the Prodigy has a 240 volt transformer with extra secondary fuses to comply with stringent IEC safety regulations.

2.2.2 KEYBOARD CIRCUIT AND ASSOCIATED CIRCUITRY

The keyboard circuit consists of a 32-note F to C dual-contact keyboard, constant current source, sample-hold amplifier with linear glide and a summing amplifier.

Integrated circuit U11B feeds a constant 0.84mA through thirty-one 100 ohm resistors in the keyboard

producing 1 volt per octave. The "Kybd Scale" trim-pot R92 adjusts this current for 1 volt per octave across the keyboard resistor string. When a key is depressed, two things happen: a voltage corresponding to the depressed note appears first at pin 5 of U12B and then +12 volts appears on the trigger buss which activates the sample-hold circuit and the dual envelope generator.

Operational amplifier U12B, GLIDE control R83, transistor Q20 and operational amplifier U12A form a combination sample-hold amplifier and a linear glide circuit. As long as the trigger voltage remains on, the output of U12A will track the pitch voltage from the keyboard. When all keys are released, the trigger voltage disappears. Q20 turns off and C25 and U12A "hold" the last pitch voltage. The pitch and trigger contacts on the keyboard are arranged so the trigger will disappear before the pitch to ensure that the sample-hold will remember the correct pitch. GLIDE control R83 and capacitor C25 form a lag circuit inside the sample-hold feedback loop which produces linear glide between notes. At low resistance values of R83, two successive notes played on the keyboard will appear as discrete pitch jumps, but as the value of R83 is increased, the pitch will glide between notes.

The output of U12A is routed to U11A, where it is summed with the pitch wheel voltage, the tune control and oscillator modulation voltage selected from OSCILLATOR MOD switch SW7. Diodes CR3 and CR4 provide a small electrical dead band in the pitch wheel to compensate for play in the wheel's mechanical detent. The inverted signal from U11A is routed to both oscillators.

2.2.3 MODULATION OSCILLATOR

The modulation oscillator is a standard single operational amplifier triangle and square wave generator followed by a waveform selector switch, buffer and the modulation wheel.

The voltage on capacitor C21 oscillates between the $\pm 1.5V$ trip point set by resistors R109 and R108

The output of the top envelope generator is routed to the VCA to control loudness. The bottom envelope generator is routed to the VCF to control cutoff frequency.

2.1.6 VOLTAGE CONTROLLED FILTER (VCF)

The Prodigy uses the patented Moog 24dB per octave low pass filter with exponential control of cutoff frequency. A positive feedback loop is provided which puts a variable height resonance peak at the cutoff frequency of the filter. The filter can also be used as a sine wave oscillator.

The output of both oscillators are summed and attenuated by resistors R93, R94 and R111 and then applied to the base of Q31. Transistors Q31 and Q32 convert the input signal into a differential signal current in the ladder. The collectors, capacitors and the next emitters form a 1-pole current controlled low pass filter. The cutoff frequency of the filter is directly proportional to the standing current in each leg of the ladder. The four stages in the ladder add up to a four-pole filter.

The differential signal voltage is buffered by a differential Darlington stage consisting of transistors Q20, Q21, Q24 and Q25. The signal is routed to the VCA U18 and to the emphasis amplifier U17B. This converts the differential voltage into a single ended output which is applied to the FILTER EMPHASIS control R140.

Since the total phase shift equals 180 degrees at the cutoff frequency of the filter and the feedback signal is injected into the minus input of the filter, we get positive feedback. This puts a resonance peak in the response of the filter at the cutoff frequency. The height of the peak depends on the setting of the FILTER EMPHASIS control R140. At full emphasis, the filter will oscillate, producing a sine wave. "Emphasis"

trimpot R139 sets the oscillation threshold and resistor R142 adjusts the filter output offset.

As previously stated, the cutoff frequency of the filter is controlled by the standing current in the filter. The standing current is generated by transistor Q34 and integrated circuit U15E, a poor man's exponential voltage to current converter. For every 18mV increase in base voltage on transistor Q34, the current through U15E doubles, resulting in an exponential control response.

The control signals for cutoff frequency are generated in many circuits. The FILTER CUTOFF FREQUENCY control R115 allows manual settings of the cutoff frequency from the front panel. The FILTER KYBD TRACKING switch SW6 allows the filter to track the keyboard in one-half scale (2 octaves of keyboard movement per octave of filter movement) or full scaling with scale set by "Filter Scale" trimpot R122. The FILTER MOD switch SW8 routes the output of the modulation wheel to the filter. Lastly, the VCF envelope generator is routed through the FILTER CONTOUR AMOUNT control R120, allowing the envelope waveform to sweep the filter.

2.1.7 VOLTAGE CONTROLLED AMPLIFIER (VCA)

The VCA uses an operational transconductance amplifier as a control element. Integrated circuit U18 takes the differential signal voltage from the VCF and amplifies it. The gain of U18 is proportional to the current flowing into pin 5. This current is supplied by transistor Q28, which is controlled by the VCA envelope generator.

The amplified voltage appears across resistor R126, where it is buffered by integrated circuit U17A. The output of U17A is routed to the MASTER VOLUME control R128 and then to output jack J1. "VCA Balance" trimpot R129 compensates for the input offset of U18 to reduce control signal bleed-through.

The sawtooth is converted to a 6 volt 10% duty cycle pulse by comparator U6B. All three waveforms are routed to OSC 1 WAVEFORM selector switch SW4 and the selected voltage is routed to OSC 1 LEVEL control R54.

There are a few adjustments in oscillator 1. "Osc 1 Scale" trimpot R7 sets the volts per octave and "Osc 1 Freq" trimpot R3 sets the reference frequency (transposes the keyboard). Since the exponential current source goes flat at higher currents, "Osc 1 Hi End" trimpot R42 compensates the oscillator to correct the tuning error resulting from this effect.

As previously stated, oscillator 2 is almost identical to oscillator 1 but differs in the following areas: OSC 2 INTERVAL control R21 varies frequency of oscillator 2 \pm a fifth from oscillator 1; oscillator 2 is tuned an octave higher than oscillator 1; oscillator 2 can be synchronized to oscillator 1, and the pulse width is a 50% duty cycle square wave.

OSC 2 INTERVAL CONTROL R21 is connected to the base of Q7. Therefore, this control transposes oscillator 2 directly without affecting oscillator 1. One megohm resistors are used instead of the 2 megohm resistors used in oscillator 1. Therefore, the reference current is doubled resulting in oscillator 2 being an octave higher than oscillator 1.

An extra reset, FET Q13, is connected across capacitor C14 to provide OSCILLATOR SYNC with the gate of transistor Q13 connected through SYNC switch SW3. When switch SW3 is OFF, Q13 is turned off and the PITCH WHEEL moves both oscillators. When switch SW3 is ON, Q13 is connected to reset comparator U6A. Oscillator 1's reset pulse will also reset oscillator 2 and therefore the fundamental frequency of oscillator 2 is locked to oscillator 1. The SYNC switch SW3 also disconnects the PITCH WHEEL from U11A and routes it directly to transistor Q7 of U3A. Therefore, the PITCH WHEEL shifts the upper harmonics of oscillator 2.

2.1.5 ENVELOPE GENERATORS

The Prodigy has two independent four-part envelope generators, one for the VCA and one for the VCF. Each envelope generator has three controls:

ATTACK time (R147 and R150), INITIAL FINAL DECAY time (R155 and R163), and SUSTAIN level (R159 and R166). RELEASE switch SW10 is provided to activate the final decay mode. Since both envelope generators are identical, the operation of the one for the VCA will be the only one discussed.

The envelope generator is activated by a V-trigger from the keyboard. This V-trigger is routed to trigger generator U21 which produces an S-trigger, a buffered V-trigger and a 200 microsecond S-trigger pulse with every V-trigger from the keyboard. The first S-trigger from U21A turns switch U19C off which removes the discharge path of capacitor C40.

The V-trigger from integrated circuit U21B and the S-trigger pulse from U19C activates the dual timer U23. This puts +12 volts at pin 5 of U23 which is inverted by integrated circuit U19A. This grounds pin 3 of U19B which turns the P-channel FET on, charging capacitor C40 through the ATTACK time control R147 and resistor R154. The value of R147 sets the charging time of capacitor C40 and therefore the attack time. The voltage on capacitor C40 is buffered by integrated circuit U22A. When the voltage at the output of U22A reaches +8 volts, the dual timer changes from the ATTACK mode to the DECAY mode. Pin 5 of U23 drops to ground, which turns the P-channel of U19B off and the N-channel on. Capacitor C40 is discharged through resistor R154 and LOUDNESS CONTOUR DECAY RELEASE control R155. R155 sets the discharge rate and therefore the decay time. Capacitor C40 is discharged to the voltage on the emitter of transistor Q36, which is called the sustain voltage. The voltage at this point varies between 0 and 8 volts depending on the setting of the SUSTAIN control R159. As long as any key on the keyboard is depressed, capacitor C40 will hold at the sustain voltage.

When all the keys on the keyboard are released, the trigger generator returns to normal and dual timer U23 is reset back to zero. What happens next depends on the setting of the FINAL DECAY RELEASE switch SW10. In the OFF position, capacitor C40 is discharged very quickly to ground through resistor R148. When switch SW10 is ON, capacitor C40 is discharged through LOUDNESS CONTOUR DECAY/RELEASE control R155 to ground. Therefore, the discharge rate is the same as the initial decay rate.

Integrated circuit U14E, resistors R104 and R105 produce a 0 to 3 volt square wave.

MOD SHAPE switch SW9 selects the triangle or the square, routes it to buffer U13B and then to MODULATION wheel R171. R171 has a special taper which allows the wiper to reach almost full value in 100 degrees of rotation. The output of the MODULATION wheel R171 is routed to switches SW7 OSCILLATOR MOD and SW8 FILTER MOD to select oscillator modulation and/or filter modulation.

2.1.4 OSCILLATORS 1 AND 2

The oscillators used in the Prodigy consist of a temperature regulated current source, a precision sawtooth oscillator, triangle converter and a pulse generator. Since oscillator 2 is almost identical to oscillator 1, oscillator 1 will be described fully with the minor differences in oscillator 2 noted later.

The linear voltage to exponential current converter consists of Q2, reference voltage source Q3 and U2A and temperature regulator Q5, U2B, Q6 and Q4.

The formula for the current through the collector of Q1 equals:

$$I_{CQ1} = I_{REF} \times e^{\frac{V_{in}}{V_T}}$$

$$I_{CQ1} = \frac{I_{C03}}{I_{C02}} e^{\frac{V_{in}}{V_T}}$$

Where:

T = absolute temperature in degrees Kelvin

q = 1.6×10^{-19} charge on an electron

K = 1.38×10^{-23} (Boltzmann's Constant)

I_{REF} = reference current through Q2.

I_{C0} = reverse saturation current of the transistor

V_T = $\frac{KT}{q}$ = 28mV at room temperature

V_{in} = (V_{BEQ2} - V_{BEQ3})

The reference current is maintained by U12A which senses the voltage drop across resistors R1 and R2 and pulls current out of the emitter of transistor Q3 to maintain this voltage drop at 12 volts. From the formula, the current through transistor Q2 is directly proportional to the reference current. OSCILLATOR 1 OCTAVE switch SW1 arranges the resistors

R1 and R2 to provide exact octave changes in the reference current which causes octave changes in the current from transistor Q2.

For every 20mV increase in voltage on the base of transistor Q2 or for every 20mV decrease on the base of transistor Q3, the current through Q2 doubles. Resistors R9 and R6 and "Osc 1 Scale" trimpot R7 scale the input to the standard 1 volt per octave keyboard voltage. "Osc 1 Freq" trimpot R3 sets the oscillator frequency by offsetting the current source. Capacitor C1 prevents the reference current loop from self oscillating.

Since temperature changes affect the scale factor (volts per octave) and therefore keyboard tuning, transistors Q2 and Q3 are in a transistor array which is maintained at 55° C by a temperature regulating loop. The entire chip is heated by the power dissipated by transistor Q4. The more current pulled from Q4 by Q6, the higher the chip temperature. Transistor Q5 is an electronic thermometer with a -2mV per degree centigrade temperature co-efficient. U2B compares the chip temperature with the desired temperature set on "OSC 1 CHIP TEMP" trimpot R14. Operational amplifier U2B then adjusts the drive to Q6 to maintain the correct temperature.

The oscillator consists of voltage source U5A, timing capacitor C8, buffer U7, comparator U6A and electronic switch Q14. As stated before, the linear keyboard voltage produces a current through Q2 that varies at 1 volt per octave. This current charges capacitor C8, producing a downward linear ramp starting at 6 volts. Operational amplifier U7 and transistor Q15 form a voltage follower which tracks the voltage on capacitor C8. When the voltage at the emitter of transistor Q15 reaches zero volts, the output of U6A jumps to 6 volts for approximately 1 microsecond. This turns transistor Q14 on for 1 microsecond, discharging capacitor C8 to 6 volts. Transistor Q14 then turns off again, the process repeats, and a sawtooth waveform appears on the emitter Q15.

Transistor Q15 also converts the sawtooth to a triangle wave. When the sawtooth is below 3 volts, Q15 acts as a simple inverter. But above 3 volts, Q15 saturates and therefore the collector follows the input voltage. This converts the sawtooth to a triangle wave. Integrated circuit U5B amplifies and offsets the output of transistor Q15 to produce a 6 volt triangle.

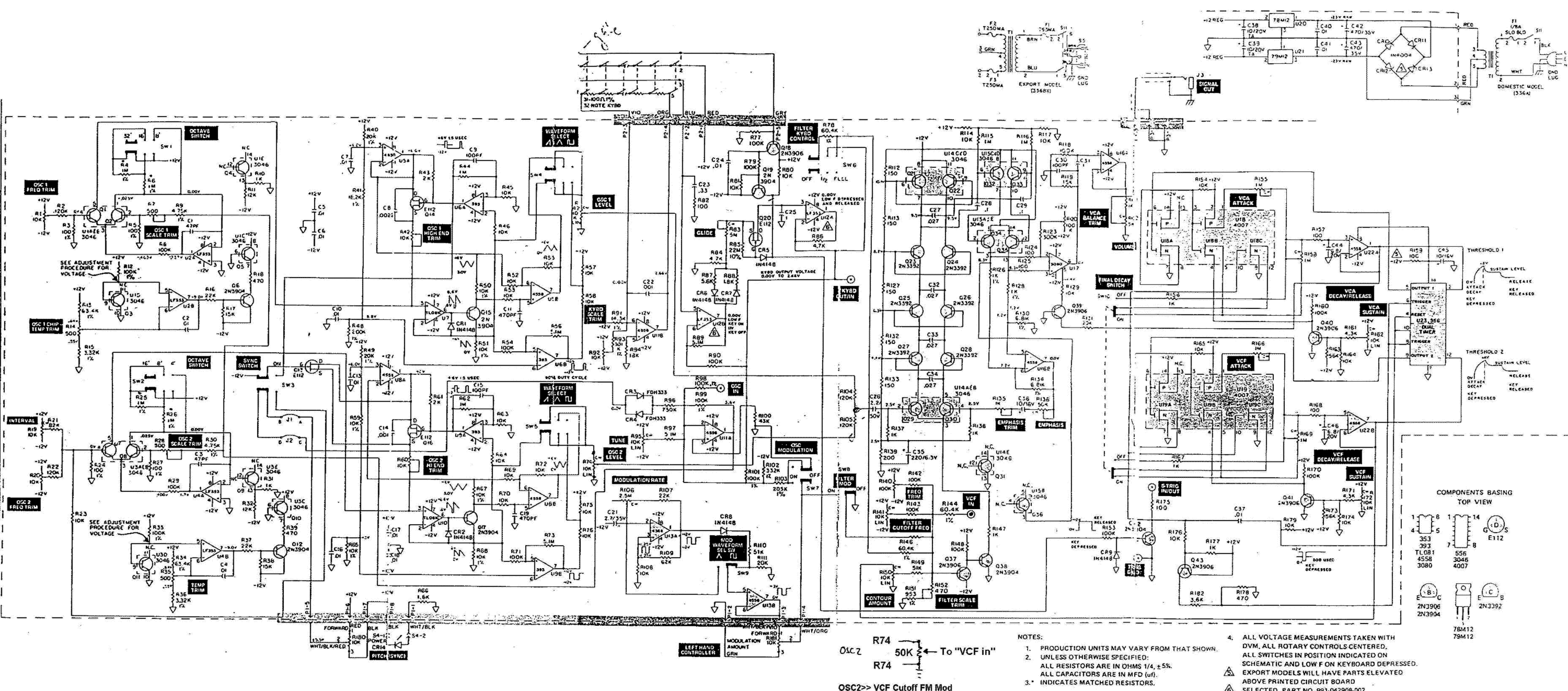

COMPONENTS BASING TOP VIEW

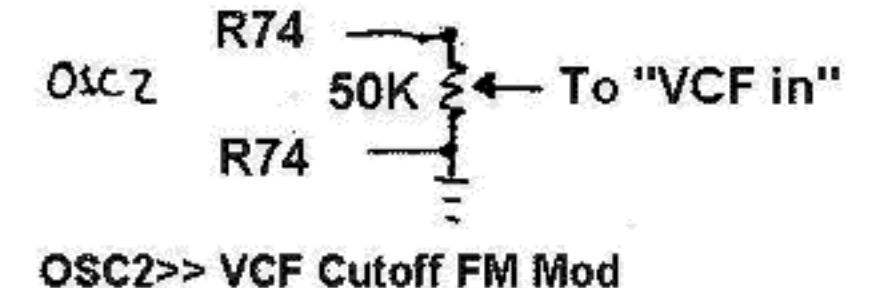
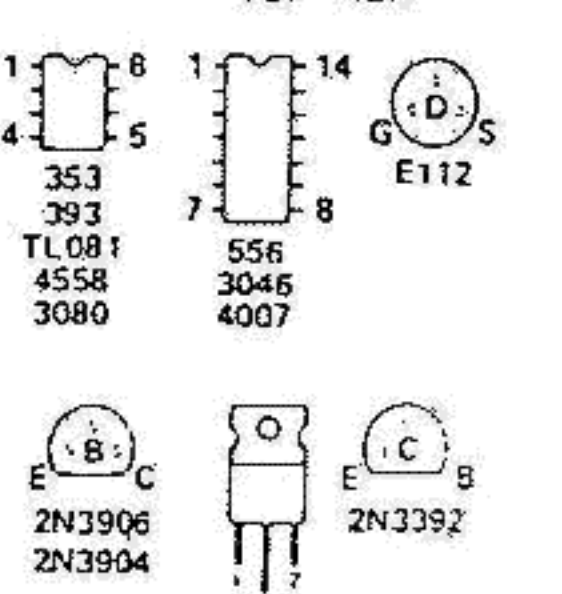

NOTES:

1. PRODUCTION UNITS MAY VARY FROM THAT SHOWN.
2. UNLESS OTHERWISE SPECIFIED: ALL RESISTORS ARE IN OHMS 1/4, ±5%. ALL CAPACITORS ARE IN MFD (uf).
3. * INDICATES MATCHED RESISTORS.
4. ALL VOLTAGE MEASUREMENTS TAKEN WITH DVM. ALL ROTARY CONTROLS CENTERED. ALL SWITCHES IN POSITION INDICATED ON SCHEMATIC AND LOW F ON KEYBOARD DEPRESSED. EXPORT MODELS WILL HAVE PARTS ELEVATED ABOVE PRINTED CIRCUIT BOARD

SELECTED, PART NO. 991-042908-002