

OPERATION AND MAINTENANCE MANUAL

**DYNAMIC SIBILANCE
CONTROLLER**

MODEL 516EC

orban

ITEM	✓	PAGE	DESCRIPTION OF DWG.	ACTION	DWG. LOCUS	NOTE
1		12	SCHEMATIC (See Diagram Below)	Delete IC2, 4195T Regulator Add IC2A, 78M15 Pos. Regulator Add IC2B, 79M15 Neg. Regulator	Lower Right	ECO #0391
		10	PARTS LIST	IC2, Was "Regulator, RC4195T" IS "Deleted" IC2A Is Added "Regulator, Pos, uA 78M15UC Orban P/N 24304-901. Qty 1" IC2B Is Added "Regulator, Neg, uA 79M15AUC Orban P/N 24303-901. Qty 1"	Lower	

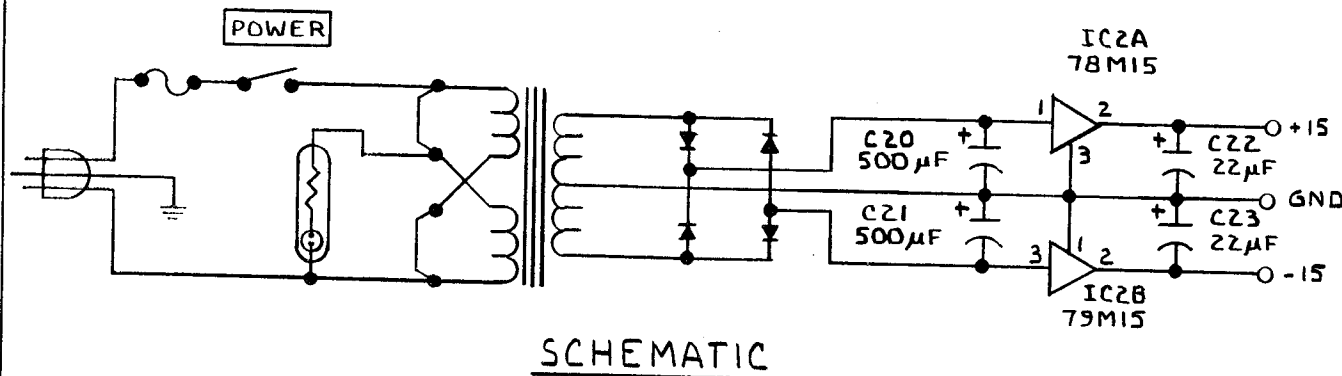

TABLE OF CONTENTS

INTRODUCTION.....	1
INSTALLATION.....	2
OPERATION.....	3
PERFORMANCE EVALUATION.....	4
Power Supply.....	4
Signal Processing Circuitry.....	4
ALIGNMENT PROCEDURE.....	5
CIRCUIT DESCRIPTION.....	5
Power Supply.....	5
Signal Processing Circuitry.....	6
MAINTENANCE.....	8
Routine Maintenance.....	8
Repair.....	8
FACTORY SERVICE.....	9
SHIPPING INSTRUCTIONS.....	9
PARTS LIST.....	10
DSC SCHEMATIC.....	12
DSC ASSEMBLY DRAWING.....	13

REGISTRATION CARD

The original purchaser should have received a postpaid Registration Card packed with this manual.

Registration is of benefit to you because it enables us to tell you of new applications, possible performance improvements, service aids, etc., which may be developed over the life of the product. It also provides us with the date of sale so that we may more promptly respond to possible claims under Warranty in the future (without having to request a copy of your Bill of Sale or other proof of purchase).

Please fill in the Registration Card and return it to us.

If the Registration Card has become lost or you have purchased the unit used, please photocopy the image of the card reproduced below and send it to us in an envelope. Use the address shown on the title page.

Model # _____	Serial # _____
Name or Title _____	
Organization _____	
Street _____	
City/State/Country _____	
Zip or Mail Code _____	
Purchased from _____	City _____ Date of Purchase _____
Nature of your application _____	
How did you hear about it? _____	
Comments: _____	

(Fig. 1) REGISTRATION CARD

WARRANTY

The Warranty, which applies only to the first end-user of record, is stated on the Warranty Certificate on a separate sheet packed with this manual. Save it for future reference.

Details on obtaining factory service are provided on Page 9.

DYNAMIC SIBILANCE CONTROLLER

MODEL 516EC

INTRODUCTION

The Orban Model 516EC Dynamic Sibilance Controller has been designed as a universal de-esser for the recording and motion picture industries. It offers electrical specifications consistent with other state-of-the-art audio signal processing equipment, extremely simple setup and operation, and dynamic characteristics which have been optimized for sibilance control. The Model 516EC incorporates a circuit which tracks the input level, permitting constant amounts of de-essing and audibly consistent results over an input level range of roughly 15 dB.

Because of its automatic level tracking, the 516EC is ideal for cinema de-essing, although it is equally as effective in de-essing highly equalized vocal tracks in the production of records and tapes for consumer use. The automatic level tracking implies that the levels fed into the unit can be permitted to vary through their natural dynamic range with consistent de-essing whether the voice is loud or soft.

De-essers have been with us for years, usually as frequency-dependent side-chains in limiters or compressors. However, a compressor used as a de-esser cannot function optimally if one attempts to compress and de-ess with the same device, since optimal compression ratios, attack times, and release times are quite different for the two modes of operation. In addition, such devices are usually not adjustable and often contain cheap 6 dB/octave filters which provide insufficient selectivity between sibilance frequencies and lower frequencies (where most vocal energy is actually concentrated).

It would therefore appear that a de-esser is required as the last link in the chain which includes an equalizer and perhaps a limiter or compressor. These devices all act to boost sibilants to unnatural and offensive levels; the de-esser then knocks down the sibilants without affecting the gains in presence and perceived loudness that the equalizer and compressor have provided.

The 516EC has been designed to fulfill this function in an ideal manner. When it is not de-essing, it acts as a unity-gain line amplifier. When the high-frequency level begins to exceed a certain fraction of the average peak input level (as set by the operator with the threshold control), the gain is automatically reduced to hold the output at this threshold level (the absolute value of which depends on the average peak input level at that moment in time). The 516EC attacks in 1 millisecond and releases in 15 milliseconds. Thus it can act on sibilants without affecting surrounding vocal sounds in any way.

An additional attractive feature of the 516EC is the extremely high basic quality of the channel. Substantial refinements in FET limiter technology have brought the overload/noise ratio of the unit to a rather astounding 107 dB! That is, clipping occurs at about +21 dBm into 600 ohms from 20 to 20,000 Hz, and the output noise level is typically -86 dBm measured with a 30-18,000 Hz bandpass filter. In addition, typical total harmonic distortion at +18 dBm and 1 kHz is less than 0.03%; this rises to about 0.25% at 20 kHz. The control action will not add more than 0.15% to these figures typically. This implies that the 516EC is audibly "transparent" and can be left in the circuit at all times. If de-essing is not required, the control action can be defeated with the "in/out" switch without clicks or gain changes.

INSTALLATION

The 516EC is supplied on a 1 3/4" x 19" rack panel and is designed to be mounted in a standard 19" rack. It is supplied with a three-prong grounding line cord to U.S. standards. The power transformer can be strapped to operate from 115 or 230 volt, 50-60 Hz AC power. A voltage variation of $\pm 10\%$ is permissible. Restrapping instructions are stamped on the cover of the power transformer. The shipping carton indicates how each unit was strapped at the factory; in general, each unit is strapped appropriately for its country of destination.

When the 516EC is unpacked, it should be immediately examined for shipping damage. The unit was in perfect condition when it left the factory, and any damage should be reported to the carrier immediately.

The unit should be mounted in the rack using the **appropriate** screws provided. Care should be taken to allow some ventilation, and the unit should not be operated in ambient temperatures above 45°C (113°F).

The inputs and outputs of each of the three channels of the 516EC are unbalanced. The inputs are 5.42 Kohms unbalanced bridging, while the outputs have a source impedance of less than 1 ohm and can drive 500 ohms or any higher impedance. It is neither necessary nor desirable to terminate the outputs in 600 ohms if the actual load has a higher impedance.

The fact that the inputs and outputs of the 516EC are unbalanced increases the care required in installation in order to avoid ground loops. This is a complex subject, and is beyond the scope of this manual. However, proper grounding techniques should be familiar to whomever is doing the installation.

The power line ground is connected directly to the chassis, and also to the B- (signal ground) by means of a wire connected between the PC board and a terminal lug mounted on one of the power transformer mounting screws. This can be disconnected if it is desirable to separate chassis and signal grounds in a given installation.

If the 516EC is operated in high RF fields, particularly into unbalanced equipment, it may be impossible to eliminate RF buzz or noise. Under these circumstances, the only solution is to add an input transformer, and output transformer, or both. High-quality transformers capable of handling +20 dBm should be utilized.

Input and output connectors are found on the rear apron of the chassis. These are three 140-Y type Jones strips, and are clearly labelled.

While the output amplifiers are protected from catastrophic failure due to output short circuits, such short circuits are to be avoided because they put thermal-cycle strains on the output transistors which may result in shortening their life.

As supplied, the 516EC provides unity gain, and is designed to be used with lines of +4 dBm nominal level (as read on a VU meter). This level yields a peak factor of 17 dB, and also operates the control circuitry in the correct portion of its range.

It is possible to modify the 516EC to operate from a -6 dBm nominal input level, and to provide 10 dB gain. To modify any channel (see schematic), perform the following steps:

- (1) Remove R1, a 6.8 K 5% 1/4 watt resistor, and replace with a 2.0 K 5% 1/4 watt resistor.
- (2) Remove R33, a 47 K 5% 1/4 watt resistor, and replace with a 24 K 5% 1/4 watt resistor.
- (3) Remove R34, a 47 K 5% 1/4 watt resistor, and discard.
- (4) Remove R30, a 3.3K 5% 1/4 watt resistor, and replace with a 1.8 K 5% 1/4 watt resistor.

A desoldering tool, such as the Edsyn "Soldapullt" should be used, and care should be taken not to overheat the foil of the PC board. Excess flux should be removed; one appropriate and widely available solvent is Energine Fireproof Spot Remover (gold can). Sloppy workmanship can adversely affect the long-term reliability of the PC board, and therefore the entire unit.

If this modification is performed, no realignment of the trimmers is required.

Because the threshold control and in/out switch supply DC control voltages, they may be removed from the chassis and operated up to 50 feet away if remote control capabilities are desired. Leads should be run in shielded cable like Belden 8451 with the shield grounded to the 516EC chassis.

OPERATION

The operation of the 516EC has been designed for maximum simplicity and operator convenience. It should be pointed out once again that the 516EC has been designed for use on voice only, and not on complex signals or finished mixes.

The 516EC will handle up to three vocal tracks at once, entirely independently. Each channel is usually patched between the output of the equalizer (and compressor, if used) and the input of the mixer. Nominal level should be +4 dBm, or -6 dBm if modified according to the above instructions.

To operate the 516EC, switch the "in/out" switch to "in", and adjust the threshold control until sibilance levels are pleasing. The lamp will light whenever control is taking place. To defeat the de-essing action, turn the "in/out" switch to "out." This introduces no clicks or gain changes, and may therefore be done in the middle of a program without any precautions.

The operator should note that the 516EC is actuated by frequencies above 6 kHz, and will therefore not work properly on limited-range or lowpass filtered material. In cinema applications, any lowpass filtering of dialogue should be done after the 516EC.

PERFORMANCE EVALUATION

Power Supply

When evaluating the performance of the power supply, the following parameters should be checked:

- 1) Unregulated supply voltage: between 18 and 26 volts DC, depending on line voltage and load.
- 2) DC output voltage: ± 15 volts ± 0.5 volts. The absolute value of the output voltages should be within 0.3 volts of each other. This specification should hold with line voltages from 105 - 125 volts (or 210 - 250 volts).

NOTE: If the output voltage ever rises above 15.5 volts, this implies that IC2 is defective. The regulator, IC2, is internally protected against excess current and thermal overload. It will automatically shut down if its output is overloaded or short-circuited. Therefore, before replacing IC2, possible causes of excessive current draw elsewhere in the circuitry should be investigated. Low output voltage can be caused by excess current draw elsewhere, or by failure of IC2.

- 3) Ripple and noise: less than 1 mv rms from either supply, measured with a 30 - 18,000 Hz bandpass filter.

Signal Processing Circuitry

Equipment required:

- 1) low-distortion audio oscillator
- 2) AC VTVM
- 3) harmonic distortion analyzer
- 4) oscilloscope

Connect the output of the oscillator to the input of the 516EC channel under test. In/out switch out. Connect the oscilloscope to the output of the 516EC channel under test. Apply a 20 kHz sine wave to the input and advance the level until the output is clipped as observed on scope. The AC VTVM should indicate a level higher than +19 dBm if connected to the output.

Reduce the input level until the output level is +18 dBm. Measure the input level. It should be between +17 and +19 dBm.

Measure the total harmonic distortion at the output. It should not exceed 0.5%.

Adjust the threshold control to "0", and switch the in/out switch in. The level should go down to around +14 dBm. Measure the harmonic distortion. It should be around 0.5%.

Adjust the threshold control between "0" and "10". The output level should change over 20 dB. Adjust the threshold control to "5" and reduce the output of the generator 20 dB. The output level should drop approximately 20 dB. This tests the operation of the level-tracking circuit.

Apply a 100 Hz 0 dBm signal to the input of the 516EC. Observe the waveform at TP1 with the scope. It should be notched on top. Now increase the frequency to 500 Hz. There should be no notch, only a slight sawtooth on the DC level. This tests the operation of the nonlinear recovery time circuit in the level tracking detector.

Disconnect the oscillator and measure the output noise of the 516EC through a 30-18,000 Hz bandpass filter. It should not exceed -80 dBm and will typically be -86 dBm. Hum is usually due to grounding problems in the measuring setup: the equipment must be grounded to the Jones strip, not the chassis.

ALIGNMENT PROCEDURE

There are three alignment controls per channel: R41 (distortion null), R42 (VCR bias trim), and R43 (limiting). R41 is green; R42 is red; R43 is grey. If the module is replaced, all controls must be realigned. If IC2 is replaced, R42 and R43 must be realigned.

With a measurement setup like that described in the "Signal Processing Performance Evaluation" section, apply a 1 KHz sine wave to the input of the 516EC channel to be aligned. Switch the "in/out" switch "out". Adjust the generator for a +14 dBm output.

Adjust R42 until no further increase in output from the 516EC is observed. Back off R42 until the 516EC output level is 4 dB below the maximum observed output. Now adjust R41 for minimum harmonic distortion at the output. Then readjust R42 just beyond the point where no further increase in output is observed.

Remove the generator from the input. Turn the "in/out" switch to "in." Adjust the R43 counter-clockwise until the "threshold" lamp lights. Back off slightly.

NOTE: This adjustment is somewhat temperature-sensitive. Therefore, leave a bit of safety margin, or the "threshold" lamp may light again after the unit warms up!

CIRCUIT DESCRIPTION

Power Supply

The power supply is designed to provide a highly regulated ± 15 volts DC to the rest of the circuitry. The AC line voltage is applied to the primary of T1, which can be wired for 115 or 230 volt 50-60 Hz operation. The center-tapped secondary of T1 is

full-wave rectified by CR5-CR8 and the output of these diodes is smoothed by C20 and C21, yielding an unregulated output of approximately ± 22 volts DC. These voltages are applied to the inputs of IC2, a Raytheon RC4195T voltage regulator. IC2 contains all the circuitry necessary to produce a highly regulated ± 15 volt output. The regulator is frequency-compensated by means of C22 and C23 across its outputs. In addition, a number of 0.05 mfd/25 volt ceramic disc capacitors are used for local bypassing of the power supply busses at various points in the circuit.

Signal Processing Circuitry

The signal-processing circuitry consists of two main sections:

- 1) a feedback-controlled FET limiter with frequency-selective networks inside the feedback loop;
- 2) a circuit which accurately detects the positive peak level of the incoming signal and which has the ability to follow falling levels very quickly (within 5 ms) without excessive sawtooth or ripple modulation.

Most of the circuitry of the limiter is encapsulated, and failure within the module requires replacement of the entire module. This section of the manual should then help the technician determine if the failure is inside or outside the module.

The signal enters the module through R1. Inside, it is processed, and passed through a low-noise amplifier. The output stage of this amplifier -- a complementary-symmetry class AB emitter-follower -- is located outside the module. The output of this stage is fed back into the module to actuate the control circuitry, and to complete the feedback around the internal amplifier. Therefore, a failure in the output stage will cause distortion or complete loss of signal. It will also cause the control function to stop working.

The output stage is driven by the collector of a PNP transistor inside the module. The collector load consists of the diode-connected transistors Q3 and Q5, plus R14. Q3 and Q5, in conjunction with the emitter resistors R12 and R13 bias the output stage for class AB operation. Since Q3 and Q4, as well as Q5 and Q6, are thermally connected, thermal feedback is provided to stabilize the stage against temperature variations and thermal runaway.

Current limiting for short circuit protection is provided by CR2 and CR3 working with R12 and R13. If the current through the output transistors Q4 and Q6 causes the voltage across R12 or R13 to rise above about 0.6 volts, CR2 and CR3 conduct and remove drive from the output transistors, thus protecting them from excessive dissipation.

C4 is the control-voltage integration capacitor for the FET voltage-controlled attenuator. The FET is normally biased off by means of a voltage derived from R42, the VCR bias trimmer. When gain reduction is required, circuitry inside the module permits current to flow into C4, thus raising its voltage above the point determined by R42. This in turn causes the internal FET to turn on and reduce the gain.

IC3 is normally biased off by R16 and R17. However, when the voltage on C4 increases above the normal off value, this causes the non-inverting input of IC3 to go positive with respect to its inverting input, thus turning IC3 on. This in turn drives current through I2, the front-panel LED threshold indicator. Internal current-limiting circuitry in IC3 limits the current through I2 to about 20 ma. IC3 is powered by the unregulated negative supply to avoid unnecessarily loading the regulated power supply.

S1, the defeat switch on the front panel, provides +15 volts in the "out" position to defeat the control circuitry inside the module.

In addition to being applied to the module, the input signal is also applied to the level tracking circuitry. The signal enters through a frequency-dependent attenuator consisting of R33, R34, and C14. C14 rolls off the response of the attenuator at 6 dB/octave starting about 2 kHz. This signal is applied to the non-inverting input of IC5a. The stage in IC5a just before its internal output stage is connected through CR9 to Q9. Q9 in turn drives the integrating capacitor C16 and release time circuitry to be described below.

C16 is also connected to the inverting input of IC5a, and therefore forms a negative feedback loop which forces the voltage on C16 to follow the positive peak value of the signal at the non-inverting input of IC5a.

R28 provided a slow release time by itself, but guarantees that IC5a will have to turn on once each cycle to recharge C16 to make up for the small amount of charge that has leaked through R28. These turn-on pulses also turn on the output stage of IC5a, and these pulses actuate IC5b and associated circuitry. IC5b is connected as a retriggerable monostable. When no pulses are coming from IC5a, IC5b is off, because the voltage divider consisting of R24 and R25 holds its non-inverting input below its inverting input. When a positive pulse arrives from IC5a, it pulls the non-inverting input of IC5b above its inverting input, thereby turning IC5b on. This pulls the output side of C15 up to about +14 volts, and pulls the other side of C15, connected to the non-inverting input of IC5b, positive too, thus holding IC5b on.

If no other pulses arrive from IC5a, C15 will discharge through R24 and R25 in about 5 milliseconds. When C15 has discharged sufficiently, IC5b will turn off again, its output will return to -15 volts, C15 will charge through CR10, and the whole cycle is ready to begin again.

However, if pulses are received from IC5a while IC5b is still on, these pulses will pull the side of C15 connected to IC5a back up to +14 volts, thus indefinitely prolonging the timing cycle.

IC5b turns Q8 on and off, and Q8 in turn turns Q7, an N-channel JFET, on and off. When Q7 is on, it discharges C16 very rapidly.

The purpose of this circuit is to avoid the very high amount of sawtooth ripple which would result if steady-state signals were subject to a very fast release time (low value of R28), yet permit the circuit to follow changes in level very quickly. As long as the input is in a steady state condition, IC5a will continue to provide pulses to keep IC5b on. However, when the input of IC5a drops below the value stored in

C16, IC5a will stop producing pulses, IC5b will complete its timing cycle and turn on Q7, and C16 will be discharged to the new input level, at which point IC5a once more starts to produce pulses, thus turning Q7 back off.

IC4a is connected as a non-inverting buffer amplifier to couple the high-impedance level detector to the low-impedance threshold control (R40), and to make up for the loss in the R33-R34 voltage divider. R40 drives IC4b, a limiter amplifier. By placing CR11 in the feedback loop of the amplifier, IC4b can only drive the junction of R32 and R43 more positive, not more negative. Thus the most negative voltage at this junction is determined by the R32-R43 voltage divider. R31 is also in the feedback loop, and limits the maximum positive voltage at the R32-R43 junction to about +5 volts.

This junction drives the module and determines the high-frequency threshold of gain reduction. The voltage at this point represents a limited, positive peak-detected version of the output of the low-pass filter R33 - R34 - C14, as multiplied by the gain of the threshold control, R40. Thus the high-frequency threshold of gain reduction is forced to follow the input level. The purpose of the lowpass filter is to provide even more differentiation between sibilance frequencies and lower voice frequencies than the filter within the module does. The threshold voltage is limited in the negative direction because the detector in the module can be actuated on its own internal noise, and its threshold must therefore always be biased above this point.

NOTE: A very noisy track can actuate gain reduction. To cure, temporarily readjust R43.

MAINTENANCE

Routine Maintenance

The 516EC is an all-solid-state device, and the only routine maintenance required is occasional internal and external dusting, and washing the front panel to remove dirt and finger oil. The dusting routine should not be neglected, since dust can cause loss of cooling of certain components, and can cause high-resistance shorts in humid environments.

Repair

Repairs should be done by technicians thoroughly familiar with solid state circuitry, and with printed-circuit repair techniques. Excessive heat and crude techniques can cause the foil to separate from the board, and can damage individual components as well. In general, a 30-watt pencil-type iron should be used, and components should be removed with a desoldering tool such as the Edsyn "Soldapullt." Excess flux should be removed from the board, since this can absorb moisture and cause high-resistance short circuits.

The part of the 516EC responsible for its unusual low-noise and low-distortion properties has been encapsulated in an epoxy block, and any faults that develop within the block must be repaired by replacement of the block. Replacement blocks, as well as other components not easily available locally may be purchased from the factory. In addition, factory service is available at a reasonable charge throughout the life of the unit.

FACTORY SERVICE

Factory service is available through the life of the 516EC from the manufacturer:

ORBAN ASSOCIATES INC.
645 Bryant Street
San Francisco, California 94107
(415) 957-1067

During the warranty period, no charge will be made for parts or labor, subject to warranty conditions. After expiration of the warranty, a reasonable charge will be made for parts, labor, and packing. In any event, transportation charges (which are usually quite nominal) shall fall on the customer.

Before returning any unit for repair, please write or telephone for instructions, stating the trouble experienced. Often a problem can be solved by consultation, saving everyone the delay, inconvenience, and expense of actually returning the unit.

SHIPPING INSTRUCTIONS

If the original packing material is available, it should be employed. Otherwise, a carton of at least 200 lbs bursting test should be obtained which is no smaller than 22 x 15 x 9 inches.

The assembly should be packed so that there is at least 1 - 1/2" of packing material protecting every point. Cushioning material such as Air-Cap, Bubble-Pak, foam "popcorn," or fibre blankets are acceptable. Folded newspaper is not suitable. Blanket type material should be tightly wrapped around the assemblies and taped in place to prevent the unit from shifting out of its packing and contacting the walls of the carton.

The carton should be packed evenly and fully with the packing material filling all voids so that the units cannot shift in the carton. Test for this by closing but not sealing the carton and shaking vigorously. If the unit can be heard or felt moving, use more packing.

The carton should be well-sealed with 3" reinforced sealing tape applied across the top and bottom of the box in an "H" pattern. Narrower or parcel-post type tapes will not withstand the stresses applied to commercial shipments.

The package should be marked with the name of the shipper and the words, in red, DELICATE INSTRUMENTS, FRAGILE! Even so, the freight people will throw the box around as if it were filled with junk. The survival of the unit depends almost solely on the care taken in packing!

REF DES	DESCRIPTION	ORBAN P/N	VEN (1)	VENDOR P/N	ALTERNATE VENDORS (1)	QUAN/ SYS.	NOTES
------------	-------------	-----------	------------	------------	--------------------------	---------------	-------

CAPACITORS

C1	Tantalum, 47uF, 6V, 10%	21302-647				3	
C2	Polyester, .0082uF, 100V, 10%	21401-282				3	
C3	Ceramic Disc, .05uF, 25V, ±20%	21106-350				21	
C4	Ceramic Disc, 1uF, 50V, 20%	21119-510				3	
C5	Same as C3						
C6	Same as C3						
C7	Same as C3						
C14	Ceramic Disc, .0033uF, 1KV, 20%	21113-233				3	
C15	Polyester, .0033uF, 100V, 10%	21401-233				3	
C16	Tantalum, 1uF, 35V, 10%	21307-510				3	
C17	Same as C3						
C18	Same as C3						
C20	Aluminum, 470uF, 40V	21224-747				2	
C21	Same as C20						
C22	Aluminum, 10uF, 25V	21213-610				2	
C23	Same as C22						
C24	Same as C3						

DIODES

CR2	Signal, 1N4148	22101-000				15	
CR3	Same as CR2						
CR5	Rectifier, 1N4004	22201-400				4	
CR6	Same as CR5						
CR7	Same as CR5						
CR8	Same as CR5						
CR9	Same as CR2						
CR10	Same as CR2						
CR11	Same as CR2						

INTEGRATED CIRCUITS

IC2	Regulator, RC4195T	24302-101				1	
IC3	741 CAN	24002-102				3	
IC4	Dual, 4558	29202-202				3	
IC5	Dual, 749C	24201-303				3	

RESISTORS

R1	CF, ½W, 5%, 6.8K	20001-268				3	
R12	CF, ½W, 5%, 15Ω	20001-015				6	
R13	Same as R12						
R14	CF, ½W, 5%, 4.7K	20001-247				6	
R15	CF, ½W, 5%, 15K	20001-315				3	

FOOTNOTES:

SPECIFICATIONS FOR REPLACEMENT PARTS
DYNAMIC SIBILANCE CONTROLLER MODEL 516EC

CAPACITORS, DIODES, IC's, RESISTORS

REF DES	DESCRIPTION	ORBAN P/N	VEN (1)	VENDOR P/N	ALTERNATE VENDORS(1)	QUAN/ SYS.	NOTES
<u>RESISTORS</u>							
R16	CF, $\frac{1}{2}$ W, 5%, 47K	20001-347				9	
R17	CF, $\frac{1}{2}$ W, 5%, 4.7M	20001-547				3	
R18	CF, $\frac{1}{2}$ W, 5%, 10K	20001-310				12	
R24	CC, $\frac{1}{2}$ W, 5%, 12M	20011-612				3	
R25	CF, $\frac{1}{2}$ W, 5%, 430K	20001-443				3	
R27	CF, $\frac{1}{2}$ W, 5%, 200 Ω	20001-120				3	
R28	CF, $\frac{1}{2}$ W, 5%, 1M	20001-510				3	
R29	Same as R18						
R30	CF, $\frac{1}{2}$ W, 5%, 3.3K	20001-233				3	
R31	CF, $\frac{1}{2}$ W, 5%, 470 Ω	20001-147				3	
R32	CF, $\frac{1}{2}$ W, 5%, 68K	20001-368				3	
R33	Same as R16						
R34	Same as R16						
R35	Same as R18						
R36	Same as R18						
R37	Same as R14						
R41	Trimpot, Horizontal, 470K	20501-447				3	
R42	Trimpot, Horizontal, 10K	20501-310				3	
R43	Trimpot, Horizontal, 470 Ω	20502-147				3	
R44	CF, $\frac{1}{2}$ W, 5%, 3.9K	20001-239				3	
R45	CF, $\frac{1}{2}$ W, 5%, 47 Ω	20001-047				3	
R46	CF, $\frac{1}{2}$ W, 5%, 22K	20001-322				3	
<u>TRANSISTORS</u>							
Q3	Signal, NPN, 2N4400	23202-101				12	
Q4	Same as Q3						
Q5	Signal, PNP, 2N4402	23002-101				6	
Q6	Same as Q5						
Q7	FET, MPF111	23401-101				3	
Q8	Same as Q3						
Q9	Signal, PNP, 2N4125	23001-101				3	
Q10	Same as Q3						
<u>MISCELLANEOUS</u>							
	PCB	30016-000				1	
	Power Transformer	29005-000				1	
	Control Module	30020-000				3	
	Threshold Control	20710-000				3	
	I.C. Socket, 14 Pin, Dip	27151-000				3	
	Clip, Heat Equalizing	16002-000				6	
	Heatsink	16003-000				1	
	Lamp, LED, Red	25103-000				3	
	Neon Pilot	25201-000				1	
	Fuseholder	28005-001				1	
	AC Switch	26001-001				1	
	Toggle Switch	26037-001				3	

FOOTNOTES:

SPECIFICATIONS FOR REPLACEMENT PARTS
DYNAMIC SIBILANCE CONTROLLER MODEL 516EC

RESISTORS, TRANSISTORS, MISC.

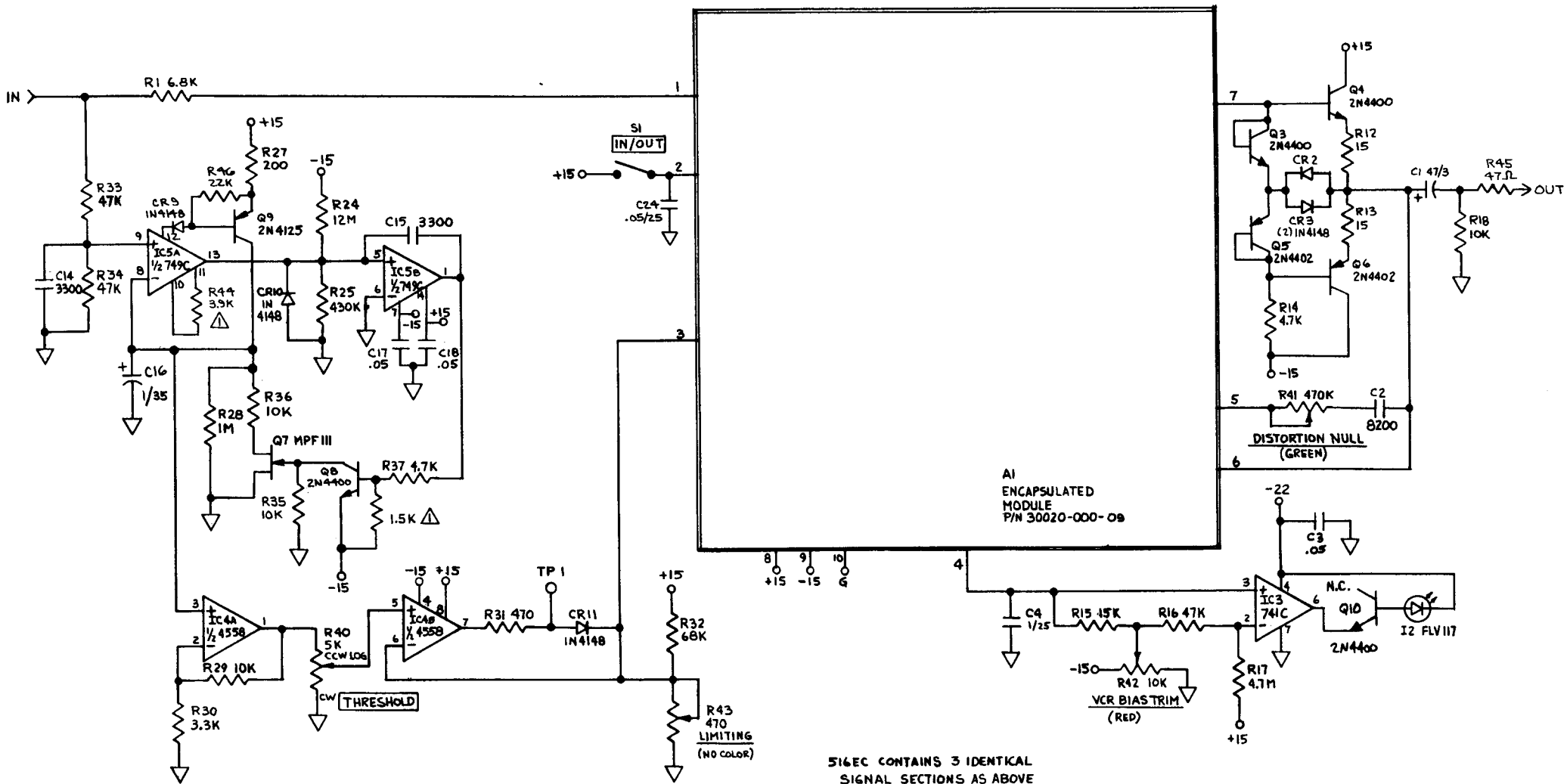

516EC CONTAINS 3 IDENTICAL SIGNAL SECTIONS AS ABOVE

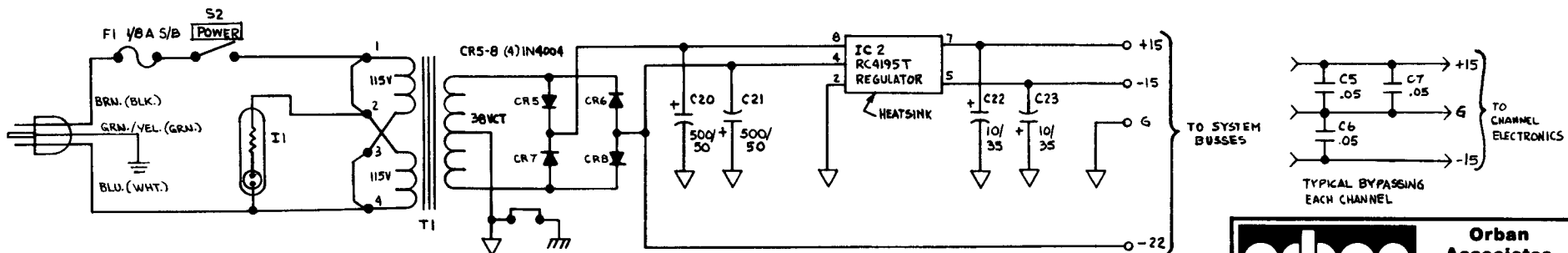

RESISTORS ARE 1/4 W 5% UNLESS OTHERWISE NOTED

△ FACTORY SELECTED
NOTES:

60003-000-08

Orban Associates Inc.

TITLE: SCHEMATIC
DYNAMIC SIBILANCE CONTROLLER
MODEL 516EC

SEE NOTE 1

THERMALLY COUPLED WITH HEATSINK COMPOUND

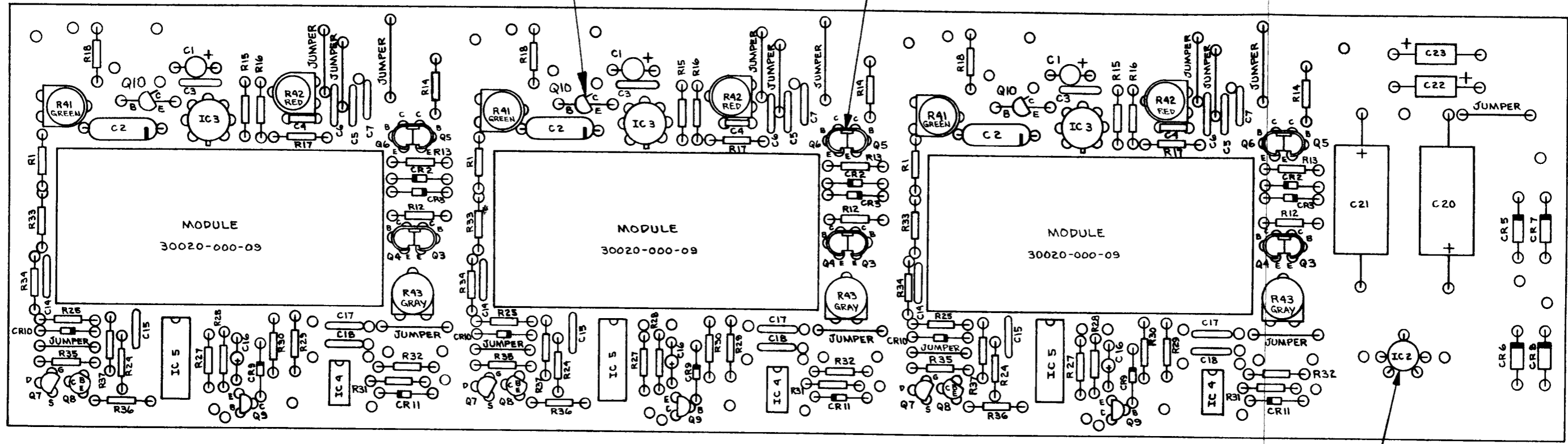

HEATSINK INSTALLED (TO-99)

orban Orban Associates Inc.
TITLE: ASSEMBLY DRAWING
DYNAMIC SIBILANCE CONTROLLER
MODEL 516EC