

Operating Manual

De-Esser

Model 536A

orban[®]

IMPORTANT NOTE: Refer to the unit's rear panel for your Model Number.

Model Number:	Description:
536A/U	Dynamic Sibilance Controller/De-Esser, 2 ch 115V
536A/E	Dynamic Sibilance Controller/De-Esser, 2 ch 230V
536A/UT	Dynamic Sibilance Controller/De-Esser, 2 ch 115V Output Transformer
536A/ET	Dynamic Sibilance Controller/De-Esser, 2 ch 230V Output Transformer

OPTIONS:

Model Number:	Description:
RET023	Output Transformer Retrofit Kit for 536A
SC1	Security Cover (CLEAR, BLUE, or WHITE)

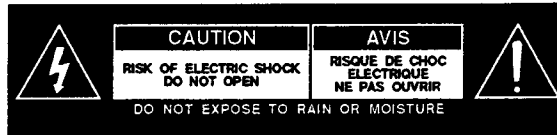

CAUTION: TO REDUCE THE RISK OF ELECTRICAL SHOCK, DO NOT REMOVE COVER (OR BACK). NO USER SERVICEABLE PARTS INSIDE. REFER SERVICING TO QUALIFIED SERVICE PERSONNEL.

WARNING: TO REDUCE THE RISK OF FIRE OR ELECTRICAL SHOCK, DO NOT EXPOSE THIS APPLIANCE TO RAIN OR MOISTURE.



This symbol, wherever it appears, alerts you to the presence of uninsulated dangerous voltage inside the enclosure — voltage that may be sufficient to constitute a risk of shock.



This symbol, wherever it appears, alerts you to important operating and maintenance instructions in the accompanying literature. Read the manual.

IMPORTANT NOTE: Refer to the unit's rear panel for your Model Number.

Model Number:	Description:
536A/U	Dynamic Sibilance Controller/De-Esser, 2 ch 115V
536A/E	Dynamic Sibilance Controller/De-Esser, 2 ch 230V
536A/UT	Dynamic Sibilance Controller/De-Esser, 2 ch 115V Output Transformer
536A/ET	Dynamic Sibilance Controller/De-Esser, 2 ch 230V Output Transformer

OPTIONS:

Model Number:	Description:
RET023	Output Transformer Retrofit Kit for 536A
SC1	Security Cover (CLEAR, BLUE, or WHITE)

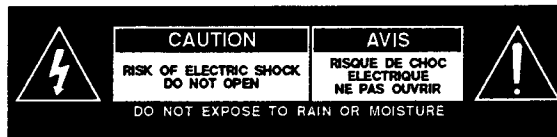

CAUTION: TO REDUCE THE RISK OF ELECTRICAL SHOCK, DO NOT REMOVE COVER (OR BACK). NO USER SERVICEABLE PARTS INSIDE. REFER SERVICING TO QUALIFIED SERVICE PERSONNEL.

WARNING: TO REDUCE THE RISK OF FIRE OR ELECTRICAL SHOCK, DO NOT EXPOSE THIS APPLIANCE TO RAIN OR MOISTURE.



This symbol, wherever it appears, alerts you to the presence of uninsulated dangerous voltage inside the enclosure — voltage that may be sufficient to constitute a risk of shock.



This symbol, wherever it appears, alerts you to important operating and maintenance instructions in the accompanying literature. Read the manual.

Operating Manual

De-Esser

Model 536A

orban[®]

This Orban product has been manufactured by AKG Acoustics, Inc.

This manual is part number 95034-000-05
50 - FB - 5/93

© Copyright 1993 by AKG Acoustics, Inc.

orban

a division of AKG Acoustics, Inc.

1525 Alvarado Street, San Leandro, CA 94577 USA
Telephone (1) 510/351-3500
Fax (1) 510/351-1001

Table of Contents



PAGE		PAGE	
1	Registration Card	11	Part D: Maintenance
1	Warranty	11	1: Performance Test And Alignment
1	Performance Highlights	11	Equipment Required
2	Part A: Introduction	11	Power Supply
2	Introduction	11	Signal Processing Circuitry
2	How It Works	13	2: Maintenance And Service
2	Limitations	13	Preventive Maintenance
2	Use Your Ears	13	Corrective Maintenance
2	Front Panel Description	13	Component Replacement
2	Rear Panel Description	13	Replacement Parts
3	Part B: Installation	13	Desoldering Of Components On Printed Circuit Boards
3	Equipment Location	15	Troubleshooting IC Opamps
3	Installation Of Options	15	Factory Service
3	Electrical Installation	15	Shipping Instructions
3	AC Power	16	3: Circuit Description
4	AUDIO	16	Input Buffer
4	Input	16	Voltage-Controlled Attenuator
4	Input Gain Strapping	17	Control Circuit
5	Output	17	Level-Tracking Circuit
5	Preferred Wiring	18	Overload Indicator
6	General Input/Output Connection Rules	19	Power Supply
7	If You've Followed The Rules And It Still Hums...	20	Appendix A: Interconnections And Grounding
8	Wiring the 536A With Single-Conductor Shielded Cable	20	Driving The 536A From High Impedance Or High Level Sources
9	Part C: Operating Instructions	20	Grounding
9	Applicability And Limitations	22	Appendix B: Specifications
9	Location In The System	23	Parts List
9	Adjustment Of The Operating Controls	29	Schematic Diagram
10	Internal Adjustment For Unusually Noisy Program Material	30	Assembly Drawing

REGISTRATION CARD

The original purchaser should have received a postpaid Registration Card packed with this manual.

Registration is of benefit to you because it enables us to tell you of new applications, possible performance improvements, service aids, etc., which may be developed over the life of the product. It also provides us with the date of sale so that we may more promptly respond to possible claims under Warranty in the future (without having to request a copy of your Bill of Sale or other proof of purchase).

Please fill in the Registration Card and return it to us.

If the Registration Card has become lost or you have purchased the unit used, please photocopy the image of the card reproduced below and send it to us in an envelope. Use the address shown on the title page.

Registration Card			
Model # _____	Serial # _____	Purchase Date _____	
Your name _____		Title _____	
Company _____		Telephone _____	
Street _____			
City, State, Mail Code (Zip), Country _____			
Nature of your product application _____			
How did you hear about this product? _____		Purchased from _____	
Comments _____			

Which magazines do you find the most useful to your job?			
<input type="checkbox"/> Broadcasting	<input type="checkbox"/> Broadcast Engineering	<input type="checkbox"/> Broadcast System Engineering	
<input type="checkbox"/> db Magazine	<input type="checkbox"/> Line Up	<input type="checkbox"/> Millimeter	<input type="checkbox"/> Mix
<input type="checkbox"/> Post	<input type="checkbox"/> Pro Sound News	<input type="checkbox"/> Radio & Records	<input type="checkbox"/> Radio World
<input type="checkbox"/> RE/P	<input type="checkbox"/> S & VC	<input type="checkbox"/> Studio Sound	<input type="checkbox"/> TV Broadcast
<input type="checkbox"/> TV Technology	<input type="checkbox"/> World Broadcasting News	<input type="checkbox"/> Radio Ink	
	<input type="checkbox"/> _____	<input type="checkbox"/> Billboard	
95208-000-01 2/93			

WARRANTY The Warranty, which applies only to the first end-user of record, is stated on the Warranty Certificate on a separate sheet packed with this manual. Save it for future reference.

Details on obtaining factory service are provided in **Part C**.

PERFORMANCE HIGHLIGHTS

- Two independent channels
- Effective, inaudible de-essing over a 15dB input range
- Active-balanced input, strappable for +4 or -10dBm
- Active-balanced output with transformer option
- Dual-LED gain reduction metering
- Overload/noise ratio typically 105dB
- Very low distortion
- Effective RFI suppression
- Top-quality professional construction
- Cost-effective 19" rack mount package
- Low cost-per-channel

Part A: Introduction

INTRODUCTION

The Orban 536A Dynamic Sibilance Controller has been designed as a universal de-esser for the recording, broadcast, and motion picture industries. It offers electrical specifications consistent with other state-of-the-art audio signal processing equipment, extremely simple setup and operation, and dynamic characteristics which have been optimized for sibilance control. The 536A incorporates a circuit which forces the threshold of de-essing to track the average input level, permitting constant amounts of de-essing and audibly consistent results over an input level range of approximately 15dB.

De-essers have existed for years, usually as frequency-dependent sidechains in limiters or compressors. However, a compressor used as a de-esser cannot function optimally if one attempts to compress and de-ess with the same device, since optimum compression ratios, attack times, and release times are quite different for the two modes of operation. In addition, such devices are often insufficiently adjustable, and often contain simple filters whose selectivity cannot provide enough differentiation between sibilance frequencies and the lower frequencies where most of the voice energy is concentrated. Further, these devices cannot simultaneously de-ess voice and maintain natural dynamic range because their thresholds are fixed.

A specialized de-esser is therefore necessary to perform sibilance control only. It is ordinarily the last piece of processing hardware in a chain which may include both an equalizer and a compressor or limiter. Both devices will tend to increase sibilance with reference to the energy of the lower-frequency vocal components; the de-esser then reduces sibilance levels until they are once again natural-sounding and do not cause overload in recording media employing high frequency preemphasis.

Many voices, especially female, produce relatively high levels of sibilant energy. This can be exaggerated by close miking techniques (especially condenser mics), and by audio processing. Such exaggerated sibilance is not only annoying aesthetically, but also can cause saturation of slow-speed tape recordings (such as cassette), resulting in severe IM distortion on sibilance. Similar problems can occur in optical film recording. In disk recording, untrackably high velocities can be produced.

The 536A controls the level of the sibilance to make it sound aesthetically natural and to avoid overload problems. When not de-essing, it acts like a high-quality amplifier.

How It Works: When the level in the sibilance band (around 6kHz) attempts to exceed a certain fraction of the peak input level (determined by the THRESHOLD control), the channel gain is automatically reduced to hold the output at this threshold level. This gain reduction occurs only during sibilance. After each sibilant, the gain recovers so quickly that subsequent vocal sounds are audibly unaffected. Because the entire channel gain is reduced (as opposed to de-essers which operate as program-controlled filters), any residual IM distortion which accompanies the original sibilance is reduced along with the sibilance itself.

Because the de-essing threshold automatically tracks the input level, the de-esser forces the balance between the sibilance and "voiced" speech to remain consistent over an input level range of more than 15dB. Thus recordings whose natural dynamic range has been preserved can be effectively de-essed.

Limitations: The 536A detects sibilance by assuming that all energy above 6kHz is sibilance. This means that a bandwidth of at least 8kHz is required for adequate operation, that the frequency range above 6kHz must be sufficiently noise-free to prevent the 536A from mistaking noise for sibilance, and that the sibilance cannot

have been previously destroyed by tape saturation or optical film cross-modulation distortion (changing the sibilance into IM distortion at a lower frequency). Such "pseudo-sibilance" (really distortion) often cannot be removed by the 536A, so it is wise to de-ess before speech is recorded onto a medium subject to such distortion, or to avoid distortion by respecting headroom limitations.

Music frequently contains high-level energy above 6kHz. Mixed vocal/musical tracks can therefore cause unpredictable results. (However, some interesting musical "special effects" have been created by using an Orban de-esser in this way. Try it on drums!)

Use Your Ears: The 536A has been designed to reduce sibilance, not eliminate it.

A certain amount of sibilance is necessary for naturalness. Overly aggressive settings of the THRESHOLD control may result in "lispings" due to unnaturally low sibilance levels, or in distortion as the de-esser begins to act on non-sibilant material. The THRESHOLD control is easy to set; your ear is the best guide.

FRONT PANEL DESCRIPTION

The THRESHOLD control adjusts the balance between sibilance and non-sibilant vocal energy.

The DE-ESSING IN/OUT switch activates or defeats the de-essing control without introducing clicks, pops, or gain changes.

The yellow NORMAL LED indicates that de-essing is occurring.

The red HEAVY LED indicates that excessive de-essing may be occurring, and that the THRESHOLD control should be backed off if unnatural sounds are being produced.

The red OVERLOAD LED indicates that the 536A circuitry is operating close to, or at, its peak clipping point, and that the output level of the equipment feeding the 536A must be reduced. This indicator is very fast and will respond before audible distortion occurs. When the overload is continuous, it is normal for the OVERLOAD LED to flash on and off.

The POWER switch and green LED pilot lamp complete the front panel.

REAR PANEL DESCRIPTION

The FUSE supplied with the 536A is a 3AG slo-blo type. A 1/8 amp fuse is adequate to protect a 536A used on either 115V or 230V service.

The INPUT and OUTPUT connectors provided allow connection via barrier strip (#5 screw). In addition, a cover plate masks holes for user-installed XLR-type connectors. A retrofit kit including these connectors is available from the factory.

The captive POWER CORD is terminated with a three-prong AC "U-Ground" plug to United States standards.

Please refer to the **Electrical Installation** section for connection instructions.

Part B: Installation

EQUIPMENT LOCATION

Vertical space of one standard rack unit (1 3/4"/4.5cm) is required.

Mounting the unit directly over large heat-producing devices like a vacuum-tube power amplifier may shorten component life and is not recommended. Ambient temperature should not exceed 113 degrees F (45 degrees C) when equipment is powered.

INSTALLATION OF OPTIONS

XLR Connector Installations: To install the optional XLR connectors, obtain (2 ea.) Switchcraft D3M and (2 ea.) Switchcraft D3F (or equivalent) connectors from a local supplier.

Remove the top cover from the chassis. Then remove the cover plate from the rear chassis apron and install each connector with a pair of #4-40x5/16" flat-head screws, nuts, and lockwashers. On each channel in turn, connect jumper wires from the barrier strip to the XLR's as follows:

Input Or Output

pin 1 chassis ground
pin 2 "-" (at barrier strip)
pin 3 "+" (at barrier strip)

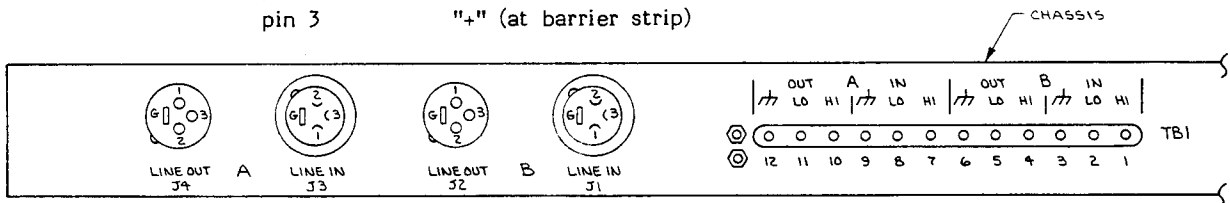

VIEW FROM INSIDE OF 536A CHASSIS

WIRE LIST

XLR CONNECTOR LINE IN			XLR CONNECTOR LINE OUT		
FROM	TO	COLOR	FROM	TO	COLOR
J3-1 (GND)	J3-G (GND)	BLK	J4-1 (GND)	J4-G (GND)	BLK
J3-2 (LO)	TBI-8 IN (LO)	BRN	J4-2 (LO)	TBI-11 OUT (LO)	GRY
J3-3 (HI)	TBI-7 IN (HI)	RED	J4-3 (HI)	TBI-10 OUT (HI)	GRN

TABLE SHOWN FOR CHANNEL A, REPLICATE FOR CHANNEL B.

WIRING DIAGRAM, XLR CONNECTORS

Balanced Output Transformer Installation: Although the 536A outputs are active-balanced, the fully-floating isolation of output transformers is sometimes desired, particularly in larger installations. Special output transformers are optionally available for installation within the chassis. If transformers were not installed at the factory, refer to the installation instructions furnished with the transformer retrofit kit, available directly from Orban.

The transformers supplied with this kit have been designed to have a negligible effect on published specifications. Should you wish to use some other transformers, it would be wise to make careful performance measurements with special attention to LF distortion and HF response at high output levels, thus determining the output level achievable with performance acceptable for your application. A transformer meeting Orban standards should produce approximately +25dBm (limited by clipping in the output amplifier) without significantly compromising performance.

The **Electrical Installation** section describes grounding procedures in the event transformers are used.

ELECTRICAL INSTALLATION



CAUTION

The installation and servicing instructions in this manual are for use by qualified personnel only. To avoid electric shock, do not perform any servicing other than that contained in the Operating instructions unless you are qualified to do so. Refer all servicing to qualified service personnel.

A *DO NOT connect power to the unit yet!*

B Check the VOLTAGE SELECTOR. This is on the rear panel.

The 8200ST is shipped configured for either 90-130V or 180-260V, 50Hz or 60Hz operation, as indicated on the rear panel. Refer to the unit's rear panel for your Model # and the inside of the front cover of this manual for your Model #'s line voltage setting. To change the operating voltage, set the VOLTAGE SELECTOR to 115V (for 90-130V) or 230V (for 180-260V) as appropriate.

C Check the value of the fuse and change the fuse if the value is incorrect.

Use a 1/2-amp 3AG 250V Slow-Blow for 115V operation, or 1/4-amp "T" type (250mA) Slow-Blow fuse for 230V operation.

D Check power cord.

AC power passes through an IEC-standard mains connector and an RF filter designed to meet the standards of all international safety authorities.

The power cord is terminated in a "U-ground" plug (USA standard), or CEE7/7 plug (Continental Europe), as appropriate to your 8200ST's Model #. The green/yellow wire is connected directly to the 8200ST chassis.

If you need to change the plug to meet your country's standard and you are qualified to do so, see Figure 2-1. Otherwise, purchase a new mains cord with the correct line plug attached.

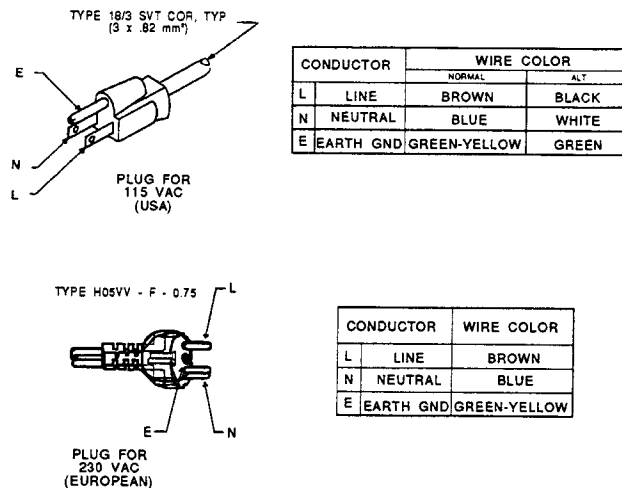

Figure 2-1: AC Line Cord Wiring

AUDIO

Connecting the 536A De-esser to other equipment is quite straightforward. Relatively uncomplicated systems (such as "semi-pro" recording studios) tend to come together without serious grounding problems even if the wiring practices are somewhat casual, provided that high RF fields are not present. Unusual situations can be analyzed if you are familiar with the standard rules governing grounding and interfacing between balanced and unbalanced systems.

The instructions below will apply to the majority of cases. A comprehensive discussion of interconnections and grounding can be found in **Appendix A**.

Input: The electronically-balanced input of each channel of the 536A De-esser is compatible with most professional and semi-professional sound equipment, balanced or unbalanced, whose source impedance is 600 ohms or less. If it is greater (as in some vacuum-tube audiophile preamps), a minor modification may be made to the input to accommodate the situation. Please refer to **Appendix A** for further details.

Input Gain Strapping: The unit may be internally strapped for either +14dB or 0dB gain, corresponding to nominal input levels of -10dBm or +4dBm respectively. [These gains are referred to an unbalanced output connection (taken between the "+" output terminal and circuit ground). Referred to a balanced output connection, the gains are 6dB higher: +20dB or +6dB.] The absolute overload point is +6dBm (+14dB gain) or +20dBm (0dB gain).

The unit is shipped with 0dB gain. To increase the gain of either channel to +14dB, remove the top cover and locate plug-in jumpers "A" and "B" for that channel. Move these jumpers according to Fig. B-2 to achieve the desired gain.

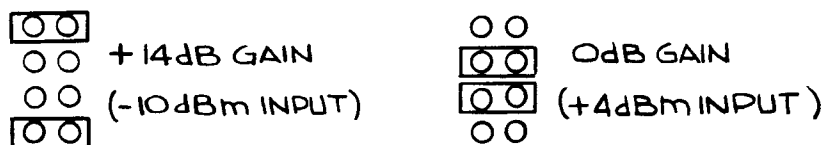

Fig. B-2: Gain Jumpers

Output: The output of each channel of the 536A is electronically-balanced to ground unless the optional output transformer is fitted, in which case it is fully-floating.

If the optional transformer is not fitted, the source impedance of each leg is 47 ohms in parallel with 1000pF to the chassis (for RFI suppression). Each output is capable of driving loads of 500 ohms or higher and requires no specific load impedance.

If an unbalanced output is required (to drive unbalanced inputs of other equipment), it should be taken between the "+" output and circuit ground. DO NOT GROUND THE "-" OUTPUT. While no immediate damage will result, this will short the output of the "-" amplifier to ground through a 47 ohm resistor, significantly stressing the output amplifier IC and possibly shortening its life due to thermal cycling.

If the output transformer is fitted, each output should be loaded by 600 ohms $\pm 10\%$ to assure correct frequency response. In particular, if the input of the driven equipment is bridging, the 536A output should be loaded with a 620 ohm 5% 1/4 watt resistor. While the transformer is ordinarily used only in a balanced system, if an unbalanced output is desired with the transformer installed, it must be taken between the "+" and "-" terminals.

Preferred Wiring: We recommend wiring with two-conductor shielded cable (such as Belden 8451 or equivalent) because signal current flows through the two conductors only. The shield does not carry signal, is used only for shielding, and is ordinarily connected to ground at one end only. The following table and diagram are applicable to a great majority of installations.

If you wish to use single-conductor shielded cable, see the section immediately below.

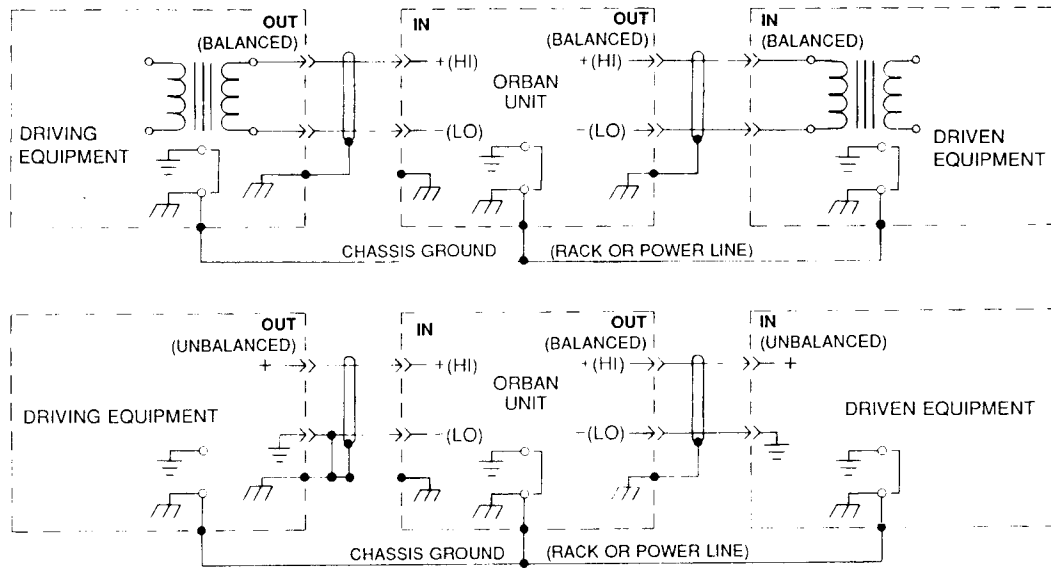

Fig. B-3: GROUNDING

TABLE 1:
GENERAL INPUT/OUTPUT CONNECTION RULES

INPUT (using 2-conductor shielded cable)

- 1) Always use "+" and "-" as the two input terminals to the 536A.
- 2) When the 536A is driven from an unbalanced source, connect shield both to circuit ground of source, and to chassis ground of 536A.
- 3) When the 536A is driven from a balanced source, connect shield at source end to chassis ground. Do not connect shield at 536A end.

OUTPUT (using 2-conductor shielded cable)

- 1) On the 536A output, connect shield at 536A end to chassis ground (whether driving balanced or unbalanced). Do not connect shield at other end.
- 2) When driving an unbalanced load:

If the optional 536A output transformer is not fitted, connect the the input ground of the driven equipment to the 536A's chassis ground.

If the optional output transformer is fitted, connect the input ground of the driven equipment to the 536A's "-" output.

In either case, connect the hot side of the driven equipment's input to the 536A's "+" output.

- 3) When driving a balanced load:

Connect the 536A "+" and "-" output terminals to the "+" and "-" input terminals of the driven equipment.

GENERAL

- 1) 536A chassis should always be earth-grounded (i.e. through third wire in power cord or through rack) for maximum protection from shock. Float this ground only as last resort.

IF YOU'VE FOLLOWED THE RULES AND IT STILL HUMS, READ ON: (Otherwise skip this section)

Appendix A provides a general discussion of the principles of system grounding. The paragraph below provides practical hints for curing hum problems which might arise despite your faithfully following the instructions above!

Because it is not always possible to determine if the equipment driving or being driven by the 536A has its circuit ground internally connected to its chassis ground (which is always connected to the ground prong of the AC line cord, if present), and because the use of the AC power line ground often introduces noise or other imperfections such as RFI, hum, clicks, and buzzes, the wiring techniques in the diagram are not universally applicable. Hum problems which are caused by differing ground potentials at various points in the overall system can sometimes be cured by connecting the main system ground to a solid earth ground like a cold water pipe.

If you follow the diagram and hum or noise appears, don't be afraid to experiment. If the noise sounds like a low-level crackling buzz, then probably there isn't enough grounding. Try connecting the "-" input of the 536A to a chassis ground terminal on the barrier strip and see if the buzz goes away.

A ground loop usually causes a smooth, steady hum rather than a crackly buzz. Ground loops are very rare in fully-balanced systems. If you have a ground loop, you can often break it by disconnecting one or more wires from the chassis ground(s) on the 536A's rear-panel barrier strip. (But make sure that you don't accidentally float the shields of one or more cables. Each shield must be connected at one end only. It will then perform its shielding function, but cannot introduce a ground loop.) In any case, think carefully about what is going on, and keep in mind the general principle: one and only one circuit ground path should exist between each piece of equipment!

[Bear in mind that the circuit grounds of the two channels of the 536A are connected together internally, and are also connected to the chassis. This could conceivably introduce a ground loop if you do not take this connection into account in planning your wiring. As a last resort, it is possible to open the 536A's top cover and disconnect the 536A's internal circuit-to-chassis ground jumper. This is a wire from the circuit board to a chassis ground terminal on the barrier strip. The chassis is hard-wired to circuit ground because the 536A is equipped with balanced inputs and outputs. (The balanced connections will automatically prevent ground loops in almost all situations. Disconnection of the circuit-ground/chassis-ground jumper wire should therefore never be necessary unless much of your system is unbalanced.)]

WIRING THE 536A WITH SINGLE-CONDUCTOR SHIELDED CABLE

Sometimes, in an emergency situation, the recommended two-conductor shielded cable cannot be obtained and it is necessary to wire the 536A into the system with single-conductor shielded cable. Provided that the system is small and that high RF fields are not present, this may work adequately. However, success is not guaranteed.

To wire the input, connect the hot side of the equipment driving the 536A to the inner conductor of the cable, and connect the cable's shield to circuit ground. On the other end of the cable, connect the inner conductor to the 536A's "+" input terminal, and the shield to both the "-" input terminal and chassis ground.

To wire the output, connect the shield to the 536A's chassis ground, and connect the inner conductor to the 536A's "+" output terminal, thereby obtaining an unbalanced output. (Single-conductor shielded cable cannot pass a balanced output because only one signal-carrying inner conductor is available and two are required.)

The unbalanced operation and casual intermixing of chassis and signal grounds which are inevitable when single-conductor cable is used make it very difficult to control the system grounding scheme, inviting ground loops or common-mode hum pickup. If the system hums, try disconnecting one or both shields from the 536A. (Often, the hum will get worse.) Usually, a compromise will be found which reduces the hum to an acceptable level. A full cure for any such problem must await the arrival of two-conductor cable.

Part C: Operating Instructions

APPLICABILITY AND LIMITATIONS

The 536A is extremely simple to operate. However, good results can only be achieved if the device's purpose and limitations are well-understood.

The 536A is designed to de-ess voice tracks only. Voice mixed with music or other sounds will give unpredictable results, because the 536A control circuitry may mistake strong high frequency components in other program material for sibilance, and cause "ducking" or "pumping". In addition, the 536A uses frequencies of 6kHz and above to control its action. Therefore, the minimum bandwidth required from the source material is approximately 8kHz for successful operation.

Often, IM distortion is produced by the sibilance's saturating the recording medium. If sufficient information to activate the 536A remains at 6kHz and above, the IM will be reduced in direct proportion to the sibilance because the 536A reduces gain in a broadband manner. However, if 6kHz information has been essentially destroyed (due to self-erasure, misbiasing, or other problems), then the remaining IM distortion is not sibilance and cannot be controlled by the 536A. Bear in mind that the sibilance in speech processed through a conventional telephone is almost entirely distortion caused by the carbon mic. It is therefore not practical to de-ess telephone speech because no 6kHz energy is available.

LOCATION IN THE SYSTEM

In general, the 536A should be the last processor in the chain before the recording device. Equalization and compression/limiting should be applied before de-essing. This way, the 536A "knows" the amount of added sibilance induced by the other processing, and can predictably control it to the level desired by the operator. If a compressor or equalizer is located after the 536A, then the controlled sibilance levels at the 536A's output could be disturbed by the additional processing.

ADJUSTMENT OF THE OPERATING CONTROLS

The 536A has only one operating control: THRESHOLD. In addition, there are two switches: DE-ESSING IN/OUT and POWER ON/OFF. Operation is extremely simple:

1. Turn the DE-ESSING switch ON. Starting at "0", advance the THRESHOLD control clockwise until sibilance levels sound natural. De-essing is indicated by illumination of the NORMAL GAIN REDUCTION LED. If the THRESHOLD control is advanced too far clockwise such that excessive de-essing occurs, the unit may start to act on low-frequency vocal material also. It can significantly distort such material (because of the very fast recovery time), so it is important not to try to obtain more de-essing than that which simply sounds natural. (A special non-linear control-voltage smoothing circuit assures that the fast recovery time will not distort sibilance.) In most cases, the HEAVY GAIN REDUCTION LED will warn when excessive de-essing is occurring, and that there is danger of introducing distortion.
2. If the OVERLOAD lamp lights, the input drive to the 536A must be reduced to prevent clipping of amplifiers within the 536A. If the OVERLOAD lamp seems to be coming on frequently, make sure that the 536A has not been accidentally strapped for +14dB gain (see **Input Gain Strapping** above).
3. The DE-ESSING switch affects the control loop only. Therefore, it may be freely operated in the middle of program material without clicks, pops, or gain changes.

Internal Adjustment For Unusually Noisy Program Material

The automatic level-tracking circuitry cannot be permitted to track down to extremely low levels, or noise could be mistaken for sibilance, forcing high gain reduction during pauses. The lower tracking limit is adjustable by means of an internal trimmer pot, R43. If extremely hissy tracks are being processed, it may be necessary to readjust this trimmer to accommodate the added noise. If the 536A audibly "gulps" during pauses, this trimmer should be readjusted. Because this situation is so rare, the control was not brought to the front panel.

To readjust, remove the top cover. Find R43 (for the appropriate channel) on the assembly drawing at the back of this manual. Note the normal setting. While listening to the problem program material, adjust R43 counterclockwise until the "gulping" goes away, and go a bit further for safety.

Unless this program material is typical in your application, you will probably want to readjust R43 to its standard mid-setting after you are finished with the noisy track. If left in its realigned setting, R43 may unnecessarily limit the range of input level which the 536A can process with constant de-essing characteristics.

Part D: Maintenance

1: PERFORMANCE TEST AND ALIGNMENT

[Refer to the assembly drawing and schematic at the back of this manual.]

Equipment Required:

1. VTVM or DVM
2. oscilloscope
3. low-distortion oscillator/harmonic distortion meter
(Sound Technology 1700B/1710B; H-P 339)
4. 20-20kHz bandpass filter with 18dB/octave maximally flat (Butterworth) skirts

Power Supply

1. Using the voltmeter, check the unregulated DC supply. Measure the voltage from circuit ground to both the "+" and "-" supplies. This should range between 18 and 26 volts DC, depending on line voltage and load.
2. Measure both regulated 15 volt supplies to circuit ground. Both supplies should be between 14.25 and 15.75 volts. If either supply exceeds 15.75V, it implies that its associated regulator IC is defective. If either supply is below 14.25 volts DC, refer to the **CIRCUIT DESCRIPTION** section for possible causes.
3. Using the AC VTVM section of the THD meter, measure the total ripple and noise on each power bus. This should not exceed 1 mV RMS in the 20-20kHz band.

Signal Processing Circuitry

[NOTE: The following describes alignment of CHANNEL A. The circuitry of CHANNEL B is identical, and should be aligned using the same procedure.]

1. **Setup:** Remove the 536A top cover to access the alignment trimmers. If the 536A gain jumpers "A" and "B" are not already in the +14dB GAIN position, temporarily move them there.

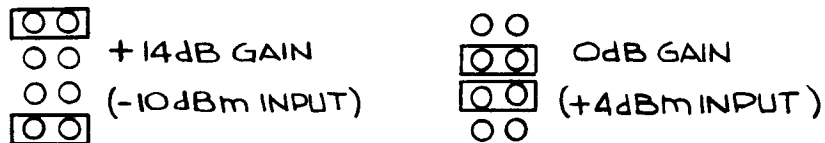

Fig. C-1: Gain Jumper Diagram



CAUTION

The installation and servicing instructions in this manual are for use by qualified personnel only. To avoid electric shock, do not perform any servicing other than that contained in the Operating Instructions unless you are qualified to do so. Refer all servicing to qualified service personnel.

Load the 536A output with a 620 ohm 1/4 watt 5% carbon resistor. Connect the output of the low-distortion oscillator to the 536A input. Connect the 536A output to the input of the THD analyzer. (If the analyzer has a balanced input, connect it to the 536A "+" and "-" output terminals. If the analyzer has an unbalanced input connect it between the 536A "-" output and circuit ground. In the unbalanced case, subtract 6dB from all 536A output levels provided in the procedure to follow.) Connect the THD analyzer to the oscilloscope in the usual way in order to observe the distortion residual and to check for oscillations or unusual waveforms.

2. **FET Bias Adjust:** Apply power to all equipment. Set the 536A THRESHOLD control to "5". Switch the 536A DE-ESSING switch IN. Adjust R44 (BIAS) fully counterclockwise. Apply -4dBm @20kHz to the 536A input and verify that the 536A NORMAL GAIN REDUCTION LED lights. Adjust R44 fully clockwise. Turn the 536A DE-ESSING switch off, and slowly turn R44 counterclockwise until no further output level increase is observed. Leave R44 at this position.
3. **Headroom:** Apply approximately +6dBm @1kHz to the 536A input and tweak the oscillator output level slightly until +25dBm is observed at the 536A output. Verify that the waveform is unclipped but that the OVERLOAD lamp is illuminated.
4. **1kHz THD:** Reduce the oscillator output level to +4dBm and measure the THD. It should not exceed 0.025%.
5. **50Hz THD:** Without changing its output level, reduce the oscillator's frequency to 50Hz. Measure the THD. It should not exceed 0.025%.
6. **20kHz THD:** Without changing its output level, increase the oscillator's frequency to 20kHz. Measure the THD. It should not exceed 0.025%.
7. **THD in Gain Reduction/THD Null:** Adjust the 536A THRESHOLD control to "0" (full counterclockwise). Turn the 536A DE-ESSING switch IN, and verify that the NORMAL GAIN REDUCTION LED lights. The output level should go down to approximately +16dBm. Measure the THD and adjust R21 (DISTORTION NULL) to null it. After null, verify that it does not exceed 0.5%.
8. **Control Loop Operation:** Vary the setting of the 536A THRESHOLD control and observe that the output level changes accordingly. If the HEAVY GAIN REDUCTION LED is on, you are close to maximum available gain reduction and further adjustment of the THRESHOLD control will not produce further decreases in output level.
9. **Input Level Tracking:** Set the 536A THRESHOLD control to "0". Reduce the input level to the 536A to -16dBm. The output level should drop approximately 20dB \pm 3dB.
10. **Non-linear Recovery Time Circuit, Level Tracking:** Apply a 100Hz +4dBm signal to the 536A input. Trigger the scope from the oscillator output, and observe the output of IC5A. (This appears on a pad on the PC board marked "E5".) The waveform should be a DC level equal to 4 times the peak value of the 100Hz output of IC2. There should be a large notch on top of the DC, synchronized to the 100Hz input. Now switch the oscillator to 500Hz. There should be no notch, only a slight sawtooth riding on the DC component. This tests the operation of the circuitry associated with IC4.

11. **Noise:** Remove the oscillator and place a 620 ohm resistor across the 536A input. Measure the 536A output noise through the 20-20kHz bandpass filter and verify that it does not exceed -76dBm.
12. Place R43 (LIMITING TRIM) in the center of its rotation.

THIS CONCLUDES THE PERFORMANCE TEST AND ALIGNMENT. Restore jumpers "A" and "B" to their desired positions before replacing the covers and reinstalling the unit.

2: MAINTENANCE AND SERVICE

Preventive Maintenance

The front panel may be cleaned with a mild household detergent. Stronger solvents should be avoided, as they may damage the paint, the silk-screened lettering, or the plastic control knobs.

Corrective Maintenance

All Orban products are designed to be completely free of failures throughout eternity. However, Orban research has recently discovered that there is no justice in the world, and, in fact, there is not supposed to be any.

For this reason, the following **Corrective Maintenance** section is included.

Component Replacement: All IC's in the unit are socketed and can be readily replaced from the top surface of the PC board.

Other components are soldered in place, and may be replaced following the instructions in **Desoldering of Components On Printed Circuit Boards** immediately below. Realignment is required if Q3, R20, or any alignment control is replaced.

The two potted modules on the board are not field-repairable, and must be replaced in their entirety. While either module can be replaced without realignment of the unit, diagnosing failures in the DSC Module can be tricky and is best left to the factory unless you are willing to risk the expense of replacing a possibly good module!

If filter capacitors are to be replaced, fasten them securely to the board, using the original factory installation as a model. This will prevent their breaking loose in the future from vibration.

Replacement Parts: If you have difficulty finding parts for this or any other Orban product, Orban Customer Service stands ready to supply you with the required parts at a fair price. Please call us at the telephone number shown at the front of this Manual.

Desoldering of Components on Printed Circuit Boards

It is important to use the correct technique for replacing components mounted on PC boards. Failure to do so will result in possible circuit damage and/or intermittent problems.

The circuit boards used in the 536A are of the double-sided plated-through variety. This means that there are traces on both sides of the board, and that the through-holes contain a metallic plating in order to conduct current through the board. Because of the plated-through holes, solder often creeps 1/16" up into the hole, requiring a sophisticated technique of component removal to prevent serious damage to the board.

Removal: If the technician has no practical experience with the elegant and demanding technique of removing components from double-sided PC boards without board damage, it is wiser to cut each of the leads of an offending component from its body while the leads are still soldered into the board. The component is then discarded, and each lead is heated independently and pulled out of the board with long nose pliers. Each hole may then be cleared of solder by carefully heating with a low-wattage soldering iron and sucking out the remaining solder with a spring-activated desoldering tool. THIS METHOD IS THE ONLY SATISFACTORY METHOD OF CLEARING A PLATED-THROUGH HOLE OF SOLDER!

Another technique is:

- 1) Use a 30 watt soldering iron to melt the solder on the solder (underneath) side of the PC board. Do not use a soldering gun or a high-wattage iron! As soon as the solder is molten, vacuum it away with a spring-actuated desoldering tool like the Edsyn "Soldapullit". AVOID OVERHEATING THE BOARD; overheating will almost surely damage the board by causing the conductive foil to separate from the board. Use a pair of fine needle-nose pliers to wiggle the lead horizontally until it can be observed to move freely in the hole.
- 2) Repeat step (1) until each lead to be removed has been cleared of solder and freed.
- 3) Now lift the component out.

Installation:

- 1) Bend the leads of the replacement component until it will fit easily into the appropriate PC board holes. Using a good brand of rosin-core solder, solder each lead to the bottom side of the board with a 30 watt soldering iron. Make sure that the joint is smooth and shiny. If no damage has been done to the plated-through hole, soldering of the topside pad is not necessary. However, if the removal procedure did not progress smoothly, it would be prudent to solder each lead at the topside as well in order to avoid potential intermittent problems.
- 2) Cut each lead of the replacement component close to the solder (underneath) side of the PC board with a pair of diagonal cutters.
- 3) Remove all residual flux with a cotton swab moistened with a solvent like 1,1,1 trichloroethane, naphtha, or 99% isopropyl alcohol. The first two solvents are usually available in supermarkets under the brand name "Energine" fire-proof spot remover and regular spot remover, respectively. The alcohol, which is less effective, is usually available in drug stores. Rubbing alcohol is highly diluted with water and is ineffective.

It is good policy to make sure that this defluxing operation has actually removed the flux and has not just smeared it so that it is less visible. While most rosin fluxes are not corrosive, they can slowly absorb moisture and become sufficiently conductive to cause progressive deterioration of performance.

Troubleshooting IC Opamps

IC opamps are usually operated such that the characteristics of their associated circuits are essentially independent of IC characteristics and dependent only on external feedback components. The feedback forces the voltage at the "-" input terminal to be extremely close to the voltage at the "+" input terminal. Therefore, if the technician measures more than a few millivolts between these two terminals, the IC is probably bad.

Exceptions are IC's used without feedback (as comparators) and IC's whose outputs have been saturated due to excessive input voltage because of a defect in an earlier stage. Also, be sure that the voltmeter is not interacting with these sensitive points and affecting the measured voltage. However, if an IC's "+" input is more positive than its "-" input, yet the output of the IC is sitting at -14 volts, this almost certainly indicates that it is bad. The same holds if the above polarities are reversed.

Because the characteristics of the 536A are essentially independent of opamp AC characteristics, an opamp can usually be replaced without need for recalibration. However, most of the circuitry in the DSC control loop is sensitive to opamp DC characteristics, like bias current and offset voltage. In addition, opamps with superior AC characteristics are used in the audio path. Because of this, high-performance opamps are used in many sockets. We recommend that all opamps be replaced by exact replacements.

A defective opamp may appear to work, yet it may have extreme temperature sensitivity. If parameters appear to drift excessively, freeze-spray may aid in diagnosing the problem. Freeze-spray is also invaluable in tracking down intermittent problems. But, use sparingly, because it can cause resistive short circuits due to moisture condensation on cold surfaces.

Factory Service

Please refer to the terms of your Limited One-Year Standard Warranty, which extends to the first end-user. After expiration of the warranty, a reasonable charge will be made for parts, labor, and packing if you choose to use the factory service facility. Returned units will be returned C.O.D. if the unit is not under warranty. Orban will pay return shipping if the unit is still under warranty. In all cases, transportation charges to the factory (which are usually quite nominal) are paid by the customer. In any case, products will be accepted for factory service *only* after Customer Service has issued a Return Authorization number.

YOUR RETURN AUTHORIZATION NUMBER MUST BE SHOWN ON THE LABEL,
OR THE PACKAGE WILL NOT BE ACCEPTED!

Shipping Instructions

If the original packing material is available, it should be used. Otherwise, a carton of at least 200 pounds bursting test and no smaller than 22" x 9" x 6" should be employed.

The 536A should be packed so that there is at least 1-1/2" of packing material protecting every point. A plastic wrap around the chassis will protect the finish. Cushioning material such as Air-Cap, Bubble-Pak, foam "popcorn", or fibre blankets are acceptable. Folded newspaper is not suitable. Blanket-type materials should be tightly wrapped around the 536A and taped in place to prevent the unit from shifting out of its packing and contacting the walls of the carton.

The carton should be packed evenly and fully with the packing material filling all voids such that the unit cannot shift in the carton. Test for this by closing but not sealing the carton and shaking vigorously. If the unit can be felt or heard to move, use more packing.

The carton should be well-sealed with 3" reinforced sealing tape applied across the top and bottom of the carton in an "H" pattern. Narrower or parcel-post type tapes will not stand the stresses applied to commercial shipments.

The package should be marked with the name of the shipper, and the words in red: DELICATE INSTRUMENT, FRAGILE! Even so, the freight people will throw the box around as if it were filled with junk. The survival of the unit depends almost solely on the care taken in packing!

3: CIRCUIT DESCRIPTION

Except for the power supply, both channels of the 536A are identical. Only CHANNEL A will be described.

1) Input Buffer

The signal enters the 536A in balanced form. C1, C2 shunt RF from the input leads to the chassis. These capacitors are not effective at VHF and higher frequencies; therefore, ferrite beads have been placed around the input and output leads to suppress such high frequency RF. It should be noted that this degree of RF-proofing is moderate but adequate for a vast majority of installations. However, installation next to a high-power transmitter may still cause problems. Additional RF suppression, careful examination of the grounding scheme, and other considerations familiar to the broadcast engineer may have to be used in conjunction with the 536A's built-in RF suppression.

The filtered signal is applied to IC1B, a very low-noise opamp configured as a differential amplifier. By strapping R1 and R4 into the circuit with jumpers "A" and "B", the gain of IC1B can be changed from 0dB (x1) to +14dB (x5).

When both the non-inverting and inverting inputs of IC1B are driven by a source impedance of 600 ohms or less, this amplifier is essentially insensitive to signal components that appear equally on the non-inverting and inverting inputs (such as hum), and responds with full gain to the difference between the non-inverting and inverting inputs. Thus it serves as an "active transformer". Ordinarily, best results are obtained for unbalanced signals if the non-inverting input is grounded and the inverting input is driven.

2) Voltage-Controlled Attenuator

The output of IC1B is connected to the level tracking circuitry (to be described below), and to voltage-controlled attenuator R18, R19, Q3. R18, R19 reduce the signal to the level where it is not significantly distorted by the nonlinear characteristics of Q3. Q3 is ordinarily biased off by means of a negative voltage applied to its gate through R44, R45, R20, CR9 when no de-essing is taking place. Under this condition, it does not affect the circuit, which operates as a conventional high-quality amplifier. However, when the voltage on Q3's gate is made more positive, the resistance between Q3's gate and source begins to decrease, thus introducing attenuation. The minimum gate/source resistance occurs when Q3's gate is at ground; this corresponds to maximum attenuation.

The relatively low level across Q3 is amplified to line level by low-noise opamp IC2, operating with 35dB non-inverting gain. IC2 is capable of driving 600 ohm loads without current boosters; it directly drives the "+" 536A output. It also drives IC1A, configured as an amplifier with a gain of -1. IC1A drives the 536A "-" output, providing an active balanced-to-ground output. If a true balanced floating output is required, the outputs of IC2 and IC1A are connected to the primary of an optional 600/600 ohm transformer.

Feedback is taken from the output of IC2 to the gate of Q3 through compensated attenuator R21, R20, C17, C8. This introduces one-half the signal present at Q3's drain to its gate, compensating for asymmetrical operation of Q3, thus nulling even-order distortion.

3) Control Circuit

The output of IC2 is passed to the control module, which contains frequency-selective elements and an error comparator. The frequency-selective elements cause the sensitivity of the error detector to be progressively decreased below 6kHz. Thus the error detector is maximally sensitive to sibilance frequencies and discriminates against lower-frequency vocal energy.

The output of the module is in the form of current pulses which are integrated by delayed-release integrator CR7, CR8, CR9, C17, C18, R45. C17 and C18 are charged through CR7 and CR8 to approximately equal voltages when gain reduction is demanded by the control module. However, recovery from gain reduction can only occur by discharging C18 through R45. Therefore C17 holds its charge until C18 has been sufficiently discharged to overcome the turn-on potential of CR9. This provides effective non-linear smoothing of the control voltage developed on C17, and introduced to Q3's gate through R20.

Gain reduction is detected by IC6A,B operating as a pair of comparators. Gain reduction is indicated by a voltage drop across recovery resistor R45. This is sensed by the two halves of IC6. In order to hold IC6B (NORMAL GAIN REDUCTION) off under no gain reduction conditions, its "-" input is biased slightly more positive than the R44 side of R45 by R46, R47. The "-" input of IC6A (HEAVY GAIN REDUCTION) is biased close to ground. When IC6A turns on, it indicates that almost all of the potential gain reduction available has been used.

4) Level-Tracking Circuit

The level-tracking circuit consists of IC4, IC5, and associated components. It is designed to track the peak value of the low-frequency components of the input to the de-esser, and to modify the threshold of the error comparator inside the control module. The de-essing thus becomes a constant fraction of the input level rather than having a fixed threshold.

The input signal is lowpass filtered at 6dB/octave by R28, R29, C14. The filter's output is positive peak-detected by IC4A, CR4, R30, and hold capacitor C16.

IC4B and associated circuitry form a non-linear recovery circuit which permits the level detector to follow falling signal levels very quickly (within approximately 5ms), yet to avoid unacceptable control voltage ripple which would occur if a simple recovery resistor were used to obtain this very fast recovery time.

There are two recovery resistors: R37 which supplies a slow recovery, and R36 which is switched on and off by Q4, and which supplies fast recovery when Q4 is on. (Q4 is on when its gate is grounded and off when its gate is more negative than -10 volts.)

IC4B, R31, R32, R33, R34, C15, CR6 form a retriggerable monostable. Each pulse which charges hold capacitor C16 through CR4 also charges C15 through CR5. Because C15 is 100 times smaller than C16, it is usually completely charged (to almost the +15 volt level) each time a charging pulse occurs. This holds the output of IC4B low and keeps Q4 off (through CR6 and R35), thus yielding slow recovery.

Each time a charging pulse ends, C15 begins to discharge through R31 towards -15 volts. As long as charging pulses continue to come through CR5, C15 will be recharged and Q4 will stay off. However, if there are no charging pulses for more than approximately 5ms, C15 will discharge below the reference voltage created by voltage divider R32, R33 (-10 volts), and IC4B will switch high, thus turning Q4 on and creating fast release. Clean switching is assured by hysteresis through R34.

Thus in the presence of signal, slow release occurs. If signal is absent for more than 5ms, fast release occurs.

The output of C16 is buffered by non-inverting gain-of-4 amplifier IC5A, which drives the THRESHOLD control R40. This scales the threshold voltage applied to the control module (pin 3), thus determining whether error pulses will be developed only with large amounts of high-frequency energy, or with smaller amounts.

R40 is buffered by a voltage follower/limiter which determines how far towards ground the reference voltage is permitted to go. If the reference voltage goes too far towards ground, the control module could be activated by small undesired signals like tape hiss. CR10 permits the threshold line to the control module to be driven as far positive as the "+" input of IC5B is driven, thus acting like a simple unity-gain buffer amplifier. However, if the voltage on IC5B's "+" input goes less positive than the voltage formed by voltage divider R42, R43, then CR10 turns off, and the R42, R43 divider determines the voltage applied to the threshold line. This voltage is adjusted by R43 (LIMITING TRIM), and may be field-readjusted to accommodate unusually noisy program material.

5) Overload Indicator

The output of IC1B (the highest signal-level point in the 536A) is connected to CR1 and CR2. Voltage divider R7, R8 biases the cathode of CR1 at +10V; voltage divider R11, R12 biases the anode of CR2 at -10V. If the instantaneous output of IC1B exceeds ± 10.6 volts, the appropriate diode will conduct. Positive-going overload pulses are passed through CR1 into transistor inverter Q1 and appear at Q1's collector amplified and inverted so that they are negative-going. Negative going overload pulses are passed through CR2 to Q1's collector. Thus any overload appears at Q1's collector as a negative-going pulse and is coupled through C6 to IC3 and associated circuitry, connected as a one-shot multivibrator.

Ordinarily, IC3 is held OFF (pin 6 LOW) because R14 holds IC3's inverting input at a higher voltage than voltage divider R13, R15 holds its non-inverting input. A negative-going pulse transmitted through C6 pulls IC3's inverting input down, briefly switching IC3's output HIGH. This in turn pulls IC3's non-inverting input HIGH through R16, C7, and latches IC3's output HIGH until C7 can discharge through R13, R16, R15, which normally takes about 200 milliseconds. While IC3's output is HIGH, the OVERLOAD lamp is illuminated through R17 and Q2, connected as a Zener diode. Thus very fast overloads are "time stretched" and can be easily seen.

Under continuous overload conditions, it is normal for the OVERLOAD lamp to flash on and off.

6) Power Supply

Unregulated voltage is supplied by two pairs of full wave diode rectifiers CR13, CR15 and CR14, CR16 operating into a pair of energy storage capacitors C19, C20. The power transformer T1 can be strapped for either 115 volt or 230 volt operation; the two sections of the primary are paralleled for 115 volt operation and connected in series for 230 volt operation.

The nominal unregulated voltage is ± 22 volts DC at rated line voltage. This will vary widely with line voltage variations. Regulator dropout will occur if the unregulated voltage falls below about ± 17.8 volts.

Regulated voltages are supplied by a pair of overrated 500mA "three terminal" IC regulators IC7, IC8. Because they are operated so conservatively, they can be expected to be extremely reliable. Therefore, before replacing the regulators, check to see whether other abnormalities in the circuitry (such as a shorted IC) have caused excessive current demand causing the regulator IC's to go either into current limiting or into thermal shutdown, their two built-in protective modes. If it becomes necessary to replace a regulator, be sure to replace its heat dissipator securely.

The regulators IC7 and IC8 are frequency-compensated by C21, C22 at their outputs to prevent high frequency oscillations. If C21 or C22 are ever replaced, be sure to use low-inductance aluminum electrolytics. Tantalums can fail because the current-delivering capacity of the power supply can cause a runaway condition if the dielectric is punctured momentarily; high-inductance aluminums can fail to prevent the regulators from oscillating. It is therefore necessary to check for oscillation on the power bus with an oscilloscope if C21 or C22 is replaced. In addition, small 0.05uF/25V ceramic capacitors bypass the power busses to ground locally throughout the board to prevent signal-carrying IC's from oscillating due to excessive power-lead inductance.

This concludes the **CIRCUIT DESCRIPTION**.

Appendix A: Interconnections and Grounding

Small systems usually come together easily because cable runs are usually short and the interconnections between various pieces of equipment are not terribly complex. Therefore, do not be intimidated by the seeming complexity of the discussion on interconnections and grounding below. This is more information than most people will ever need to successfully install a small system; we have included it in case things don't work right and you need to find out why.

DRIVING THE 536A FROM HIGH IMPEDANCE/ HIGH LEVEL SOURCES

Both "+" and "-" sides of the inputs are bypassed to chassis ground for RF through 1000pF capacitors. To assure common mode rejection, and to assure that these capacitors do not affect the frequency response of the system, the output impedance of the equipment driving the 536A should be 600 ohms or less. Most professional and semi-professional sound equipment will satisfy this requirement.

When jumpers "A" and "B" are strapped to provide 0dB gain, the 536A can be driven by unbalanced sources of up to 10,000 ohms such as the outputs of some vacuum tube preamps. (The +14dB gain mode reduces the 536A input impedance to the point that substantial common-mode rejection may be lost with 10K drive impedance.)

To permit driving from 10K impedances in the 0dB gain mode, remove the 1000pF capacitors from the 536A "+" inputs, and drive these inputs from the hot side of the driving equipment's outputs. (See the section below on **Grounding** for an explanation of balanced and unbalanced connections.) If the 1000pF capacitors are left in place and the source impedance is 10K, the capacitors will cause a high frequency rolloff which is 3dB down at 16kHz, and which rolls off at 6dB/octave thereafter. (This may not cause a problem with speech in all applications.)

The absolute clipping level of the 536A input is +20dBm when strapped for 0dB gain. (The clipping point is +6dBm when strapped for 14dB gain.) If levels greater than +20dBm are expected, an external loss pad must be used before the input. The Audio Cyclopedia, Section 5, contains instructions for making such pads. (Tremaine, H.M.: The Audio Cyclopedia, Second Edition, Indianapolis, Howard W. Sams & Co., Inc., 1969).

GROUNDING

Grounding serves two purposes: it joins the common references of various pieces of electronic equipment, and it shields the electronics from various electric fields (RFI and hum).

(Interference caused by magnetic fields is not decreased by conventional shielding, and special magnetic shielding materials must be used for this type of problem. In audio, such shielding is ordinarily used with low-level magnetic transducers like tape heads, magnetic phono cartridges, and dynamic microphones, and with low-level transformers. Line-level processors such as the 536A are not normally sensitive to this sort of interference.)

There are two types of ground: circuit and chassis. Circuit ground serves as a common reference for the electronics. Chassis ground permits use of the chassis as a shield in the same way that the shield on shielded cable protects the inner conductors. Whether the circuit and chassis grounds are identical, are separate, or are separable depends on the type of equipment and the interconnecting scheme.

In professional systems correct grounding is important. The general principles are these:

- 1) In an audio system, the chassis of each piece of equipment should be connected to a good common ground point (ideally a cold water pipe or a rod driven into the earth) by one and only one wire.
- 2) Meanwhile, there must be one and only one circuit ground path between each piece of equipment.
- 3) Normally, they should only be intermixed at one point: the water pipe.

It is when these requirements become confused, omitted, or redundant that problems develop. If there is a connection missing, hum and noise will result. If more than one ground path exists, then a "ground loop" may develop.

A ground loop can be viewed as a single turn of a giant transformer. Because 60Hz AC magnetic fields exist in every area served by mains power, a ground loop will have a hum current induced in it by stray AC magnetic fields. Because a ground wire has appreciable impedance, this induced current will cause a hum voltage to appear between different parts of the ground system. If great care is not taken, this hum voltage can intrude on the audio signal.

How grounding is accomplished depends on whether the equipment to be interconnected is balanced or unbalanced.

An unbalanced connection uses two terminals: "hot" and ground. Wires used in such connections are typically single-conductor shielded. (RCA plugs and two-conductor phone plugs are often used to terminate such cables.) If because of stray fields or ground loops, a hum voltage appears between "hot" and ground, then this hum will be mixed into the desired signal since the unbalanced connection cannot distinguish between the desired signal and hum.

In the case of balanced connections, audio is applied to the "+" and "-" terminals; the input responds to the difference between the voltages at the two terminals. A third terminal is connected to chassis ground and is available for the connection of the shield of the two-conductor shielded wire that would be used (Belden 8451, for example). If a hum voltage is developed between the shield and both audio wires, then the balanced input would reject this "common mode" voltage, since the input responds only to the difference in voltage between the audio wires. This ability to reject hum and noise is the primary advantage of a balanced configuration.

Referring back to the **ELECTRICAL INSTALLATION** section, notice how these rules are applied in the table and diagram.

For involved systems such as arena-type sound reinforcement, professional recording studios, or large broadcasting facilities, a formal and systematic "transmission ground system" should be worked out for the entire system. See Section 24 of The Audio Cyclopedia for details (mentioned earlier).

Appendix B: Specifications

Frequency Response: $\pm 0.25\text{dB}$,
20-20,000Hz

Total Harmonic Distortion: (de-essing
defeated): $< 0.025\%$, 20-20,000Hz,
@ + 24dBm

Total Harmonic Distortion: (de-essing
in): $< 0.5\%$ @ 6kHz

Output Noise: (20kHz bandwidth):
 $< -75\text{dBm}$. Dynamic range from noise
floor to clipping exceeds 100dB.

**Input Level Variation for Constant
De-essing:** $> 15\text{dB}$

Input Characteristics:

Impedance: $> 10,000$ ohms, active-
balanced bridging

Level: -10 or $+4\text{dBm}$ (strappable)

Gain: $+20\text{dB}$ or $+6\text{dB}$ (Dependent
on input strap; referred to balanced
output. Referred to unbalanced output,
gains are 6dB lower.)

Output Characteristics:

Impedance: Approximately 100
ohms, active-balanced-to-ground. Fully-
floating transformer output optional.
Unbalanced output available from
either output to ground.

Level: Drive capability into 600
ohms exceeds $+25\text{dBm}$, 20-20,000 Hz

Crosstalk: $< -80\text{dB}$

Attack Time: approximately 1 ms

Recovery Time: approximately 10 ms

Variable-Gain Element: junction field-
effect transistor

Indicators:

Two-element LED gain reduction
meter;

LED OVERLOAD indicator

LED POWER ON indicator

Operating Controls:

THRESHOLD control (each channel)

DE-ESSING IN/OUT switch (each
channel)

POWER ON/OFF switch

Connectors: All inputs and outputs
appear on Jones 140-Y-type barrier
strip (#5 screw).

Power Requirements: 115-230 volts
AC, $\pm 10\%$, 50-60Hz, approx. 6 watts.

Size: 19" (48.3cm) wide x $1\frac{3}{4}$ "
(4.45cm) high x $5\frac{3}{4}$ " (14.6cm) deep

Weight:

Shipping: 7 lbs. (5.2 kg)

Net (without options): 5 lbs. (2.3 kg)

Parts List

Parts are listed by part class by assembly in Reference Designator order except for certain widely used common parts such as:

Fixed Resistors
3/8" Square Trimmer Resistors
Signal Diodes

which are described generally under the appropriate heading and which must be examined to determine the exact value.

OBTAINING SPARE PARTS

Because special or subtle characteristics of certain components are exploited in order to produce an elegant design at a reasonable cost, it is unwise to make substitutions for listed parts. It is also unwise to ignore notations in the Parts List indicating "Selected" or "Realignment Required" when replacing components. In such cases, the factory should be consulted if optimum performance is to be maintained.

Orban normally maintains an inventory of tested, exact replacement spare parts to supply any present or normal future demand quickly at nominal cost.

When ordering parts from the factory, we will need all of the following information:

- The Orban Part Number, if ascertainable
- The Reference Designator for a defective component
- A brief description of the part
- From the Serial Label on the rear:
 - The exact Model Number
 - The Serial Number
 - The "M" number, if any

Orban can supply standardized Spare Parts Kits for this product during its production life. Consult your dealer or the factory for the consist of such kits and their prices.

Parts for this unit have been chosen from the catalogs of well-known manufacturers for ease in future maintenance. The U.S. headquarter addresses are listed at the end of the Parts List. Most manufacturers have extensive distribution facilities throughout the world and may often be contacted through local offices.

REF DES	DESCRIPTION	ORBAN P/N	VEN (1)	VENDOR P/N	ALTERNATE VENDORS (1)	QUAN/ SYS.	NOTES
------------	-------------	-----------	------------	------------	--------------------------	---------------	-------

MODULES

A1	Module, DSC	30585-000				2	
----	-------------	-----------	--	--	--	---	--

CAPACITORS

Chassis Assembly

C1	Ceramic, 1000V, 10%, .001uF	21112-210	CRL	DD-102		8	
C2	Same as C1						

PCB Main Assembly

C3	Mica, 5%, 33pF	21020-033	CD	CD15E0330J03		4	
C4	Same as C3						
C5	Ceramic, 50V, +80%/-20%, .005uF	21108-250	CRL	CK-502		4	
C6	Same as C5						
C7	Ceramic, 25V, 20%, .15uF	21106-415	CRL	UK25-154		2	
C8	Mica, 500V, 5%, 820pF	21024-182	CD	CD19FD821J03		2	
C9	Aluminum, 50V, 47uF	21208-647	SPR	502D476G050CD1C		2	
C10	Aluminum, 63V, 10%, 33uF	21209-633	SPR	502D336G063CC1C		2	
C11	Metalized Polycarbonate, 10%, 100V, 1.0uF	21604-510	IMB	DP2B105K		2	

Chassis Assembly

C12	Same as C1						
C13	Same as C1						

PCB Main Assembly

C14	Polyester, 100V, 10%, .0033uF	21401-233	SPR	225P33291WD3		2	
C15	Polyester, 100V, 10%, .01uF	21401-310	SPR	225P10391WD3		2	
C16	Aluminum, 63V, 10%, 1.0uF	21209-510	SPR	502D105G063BB1C		2	
C17	Polyester, 100V, 10%, 0.1uF	21401-410	SPR	225P10491WD3		4	
C18	Same as C17						
C19	Aluminum, Axial, 40V, 470uF	21224-747	SIE	B41283-470/40		2	
C20	Same as C19						
C21	Aluminum, 25V, 100uF	21206-710	PAN	ECE-A1EV101S		2	
C22	Same as C21						
C23	Ceramic, 50V, 20%, 0.1uF	21123-410	SPR	1C25Z5U104M050B		4	
C24	Same as C23						
C25	Same as C23						
C26	Same as C23						

24

FOOTNOTES:

- | | |
|---|--|
| (1) See last page for abbreviations | (4) Realignment may be required if replaced, |
| (2) No Alternate Vendors known at publication | see Circuit Description and/or |
| (3) Actual part is specially selected from | Alignment Instructions |
| part listed, consult Factory | |

SPECIFICATIONS AND SOURCES FOR
REPLACEMENT PARTS
DE-ESSER MODEL 536A
Rev. 02 9/85
MODULES/CAPACITORS

REF DES	DESCRIPTION	ORBAN P/N	VEN (1)	VENDOR P/N	ALTERNATE VENDORS (1)	QUAN/ SYS.	NOTES
------------	-------------	-----------	------------	------------	--------------------------	---------------	-------

TRANSISTORS

Q1	Signal, NPN, 2N4400	23202-101	FSC	2N4400		8	
Q2	Same as Q1						
Q3	J-FET, J111	23403-101	NAT	J111		4	
Q4	Same as Q3						
Q5	Same as Q1						
Q6	Same as Q1						

RESISTORS

Replace resistors only with the same style and with the exact value as marked on the resistor body, lest performance or stability be compromised. If the resistor is damaged, consult the factory or refer to the Schematic to obtain the value.

All common resistors not listed are generally specified thus:

Metal Film Resistors

Body: conformally-coated
 I.D.: five color bands or printed value
 Orban P/N: 2004X-XXX
 Power Rating: 1/8 Watt @ 70°C
 Tolerance: 1%
 Temperature Coefficient: 100 PPM/°C
 U.S. Military Spec.: MIL-R-10509, Style RN55D
 Manufacturers: R-0hm (CRB-1/2FX), TRW/IRC, Beyschlag, Dale, Corning, Matsushita

Carbon Composition Resistors

Body: molded phenolic
 I.D.: four color bands
 Orban P/N: 2001X-XXX (20011-20014)
 Power Rating: (70°C) 1/4 Watt (Body 0.090" x 0.250")
 1/2 Watt (Body 0.140" x 0.375")
 Tolerance: 5%
 U.S. Military Spec.: MIL-R-11, Style RC-07 (1/4W)
 or RC-20 (1/2W)
 Manufacturers: Allen-Bradley, TRW/IRC, Stackpole, Matsushita

Carbon Film Resistors

Body: conformally-coated
 I.D.: four color bands
 Orban P/N: 20001-XXX
 Power Rating: 1/4 Watt @ 70°C
 Tolerance: 5%
 Manufacturers: R-0hm (R-25), Piher, Beyschlag, Dale, Phillips, Matsushita

Cermet Trimmer Resistors

Body: 3/8" square (9mm)
 I.D.: printed marking on side
 Orban P/N: 20510-XXX
 Power Rating: 1/2 Watt @ 70°C
 Tolerance: 10%
 Temperature Coefficient: 100 PPM/°C
 Manufacturers: Beckman (72PR-series), Spectrol, Bourns, Matsushita

Chassis Assembly

R40	Pot, Single, CCW Log, "Threshold", 5K	20732-000	CTS	270 Series		2	
-----	---------------------------------------	-----------	-----	------------	--	---	--

FOOTNOTES:

- (1) See last page for abbreviations
 (2) No Alternate Vendors known at publication
 (3) Actual part is specially selected from part listed, consult Factory
 (4) Realignment may be required if replaced, see Circuit Description and/or Alignment Instructions

SPECIFICATIONS AND SOURCES FOR
REPLACEMENT PARTS

DE-ESSER MODEL 536A

Rev. 02 9/85

TRANSISTORS/RESISTORS

REF DES	DESCRIPTION	ORBAN P/N	VEN (1)	VENDOR P/N	ALTERNATE VENDORS (1)	QUAN/ SYS.	NOTES
------------	-------------	-----------	------------	------------	--------------------------	---------------	-------

SWITCHES

Chassis Assembly

S1	Switch, SPDT, "De-Essing"	26037-001	C&K	7101		2	
S2	Switch, SPST, "Power"	26002-001	CH	8280K21C		1	

MISCELLANEOUS

Chassis Assembly

F1	Fuse, Slo-Blo, 1/8A, 3AG	28004-113	LFE	313000		1	
T1	Power Transformer, 38VCT, 3.1vA	29005-000				1	
	Line Cord	28101-000	BEL	17237		1	

P/L REVISIONS

06032-000-01 FINAL
30710-000-01 MAIN PCB

FOOTNOTES:

- (1) See last page for abbreviations
(2) No Alternate Vendors known at publication
(3) Actual part is specially selected from part listed, consult Factory
(4) Realignment may be required if replaced, see Circuit Description and/or Alignment Instructions

SPECIFICATIONS AND SOURCES FOR
REPLACEMENT PARTS

DE-ESSER MODEL 536A
Rev. 01 4/83
SWITCHES/MISCELLANEOUS

Vendor Codes

AB Allen-Bradley Co., Inc. 1201 South Second Street Milwaukee, WI 53204	AD Analog Devices, Inc. One Technology Way PO BOX 9106 Norwood, MA 02062-9106	AM Amphenol Corporation 358 Fall Avenue Wallingford, CT 06492	BEK Beckman Industrial Corporation 4141 Palm Street. Fullerton, CA 92635-1025
BEL Belden Electronic Wire & Cable PO BOX 1980 Richmond, IN 47374	BRN Bourns, Inc. Resistive Components Group 1200 Columbia Avenue Riverside, CA 92507	BUS Bussmann Division Cooper Industries PO BOX 14460 St. Louis, MO 63178	CD Cornell-Dubilier Elec. Wayne Interchange Plaza 1 Wayne, NJ 07470
CH Cutler-Hammer 4201 N. 27th Street Milwaukee, WI 53216	CK C & K Components, Inc. 15 Riverdale Avenue Newton, MA 02158-1082	COR Corcom, Inc. 1600 Winchester Road Libertyville, IL 60048	CRL Mepco/Centralab A North American Philips Corp. 2001 W. Blue Heron Blvd. Riviera Beach, FL 33404
CTS CTS Corporation 905 North West Blvd. Elkhart, IN 46514	CW CW Industries 130 James Way Southampton, PA 18966	DIX Dixson, Inc. PO BOX 1449 Grand Junction, CO 81502	ECI Electrocube 1710 South Del Mar Avenue San Gabriel, CA 91776
ELSW Electroswitch 180 King Avenue Weymouth, MA 02188	EMI Emico Inc. 123 North Main Street Dublin, PA 18917	ERE Murata Erie North America 2200 Lake Park Drive Smyrna, GA 30080	EXR Exar Corporation 750 Palomar Ave PO BOX 3575 Sunnyvale, CA 94088
FSC Fairchild Camera & Instr. Corp. 464 Ellis Street Mountain View, CA 94042	GI General Instruments Optoelectronics Division 3400 Hillview Avenue Palo Alto, CA 94304	HP Hewlett-Packard Co. 640 Page Mill Road Palo Alto, CA 94304	INS Intersil, Inc. 10600 Ridgeview Court Cupertino, CA 95014
IRC International Resistive Co., Inc. PO BOX 1860 Boone, NC 28607	JEN Jensen Transformers, Inc. 10735 Burbank Blvd. North Hollywood, CA 91601	KEY Keystone Electronics Corp. 49 Bleecker Street New York, NY 10012	LFE Littelfuse A Subsidiary of Tracor, Inc. 800 E. Northwest Hwy Des Plaines, IL 60016
LT Linear Technology Corp. 1630 McCarthy Blvd. Milpitas, CA 95035	LUMX Lumex Opto/Components Inc. 292 E. Hellen Road Palatine, IL 60067	MAL Mallory Capacitor Co. Emhart Electrical/Electronic Gr. 3029 East Washington Street Indianapolis, IN 46206	MAR Marquardt Switches, Inc. 67 Albany Street Cazenovia, NY 13035
ME Mepco/Centralab A North American Philips Corp. 2001 W. Blue Heron Blvd. Riviera Beach, FL 33404	MID Midland-Ross Corporation NEL Unit/Midtex Division 357 Beloit Street Burlington, WI 53105	MIL J.W. Miller Division Bell Industries 19070 Reyes Avenue Rancho Dominguez, CA 90224-5825	MOT Motorola Semiconductor PO BOX 20912 Phoenix, AZ 85036
NAT National Semiconductor Corp. 2900 Semiconductor Drive PO BOX 58090 Santa Clara, CA 95052-8090	NOB Noble U.S.A., Incorporated 5450 Meadowbrook Ct. Rolling Meadows, IL 60008	OHM Ohmite Manufacturing Company A North American Philips Corp. 3601 Howard Street Skokie, IL 60076	ORB Orban a division of AKG Acoustics, Inc. 645 Bryant Street San Francisco, CA 94107
PAN Panasonic Industrial Company One Panasonic Way PO BOX 1503 Seacaucus, NJ 07094	PB Potter & Brumfield Division A Siemens Co. 200 S. Richland Creek Dr. Princeton, IN 47671-0001	RCA RCA Solid State Division Route 202 Somerville, NJ 08876	ROHM Rohm Corporation 8 Whatney Irvine, CA 92718
SAE Stanford Applied Engineering, Inc 340 Martin Avenue Santa Clara, CA 95050	SAN Sangamo Weston Inc. Capacitor Division PO BOX 48400 Atlanta, GA 30362	SCH ITT Schadow 8081 Wallace Road Eden Prairie, MN 55344	SIE Siemens Components Inc. 186 Wood Avenue South Iselin, NJ 08830
SIG Signetics Corporation A Sub. of US Philips Corp. 811 E. Arques PO BOX 3409 Sunnyvale, CA 94088-3409	SPR Sprague Electric Co. 41 Hampden Road PO BOX 9102 Mansfield, MA 02048-9102	SW Switchcraft A Raytheon Company 5555 N. Elston Avenue Chicago, IL 60630	TI Texas Instruments PO BOX 655012 Dallas, TX 75265
TOS Toshiba America, Inc. 2441 Michelle Drive Tustin, CA 92680	TRW TRW Electronic Components Connector Division 1501 Morse Avenue Elk Grove Village, IL 60007-57	VARO Varo Quality Semiconductor, Inc. 1000 North Shiloh Road PO BOX 469013 Garland, TX 75046-9013	WES Westlake 5334 Sterling Ctr Drive Westlake Village, CA 91361
WIM The Inter-Technical Group Inc. Wima Division PO BOX 23 Irvington, NY 10533			

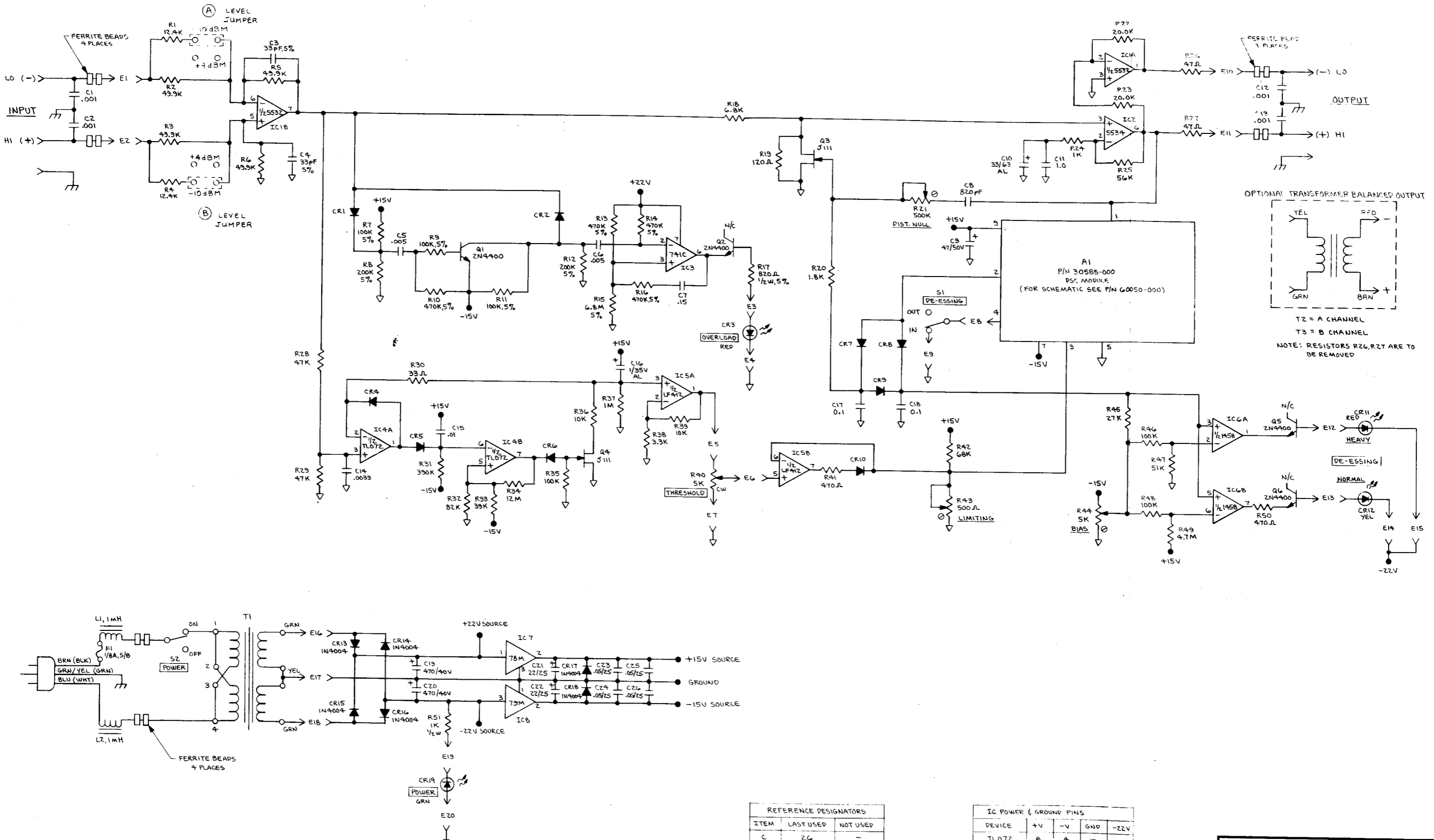

- 4. ONLY ONE CHANNEL SHOWN. OTHER CHANNEL IS IDENTICAL.
 - 3. ALL DIODES ARE 1N4148
 - 2. ALL CAP'S ARE IN MICROFARADS
 - 1. ALL RESISTORS ARE 1/8W, 1%, MF. (RN55D)
- NOTES: UNLESS OTHERWISE SPECIFIED

REFERENCE DESIGNATORS		
ITEM	LAST USED	NOT USED
C	26	-
IC	8	-
R	51	-
Q	6	-
CR	19	-
L	2	-
T	3	-

IC POWER & GROUND PINS				
DEVICE	+V	-V	GND	-22V
TL072	8	4	-	-
LF412	8	4	-	-
5532	8	4	-	-
1458	-	-	8	4
741C	7	4	-	-

urban Orban Associates Inc.

TITLE: SCHEMATIC DE-ESSER 60070-000-02

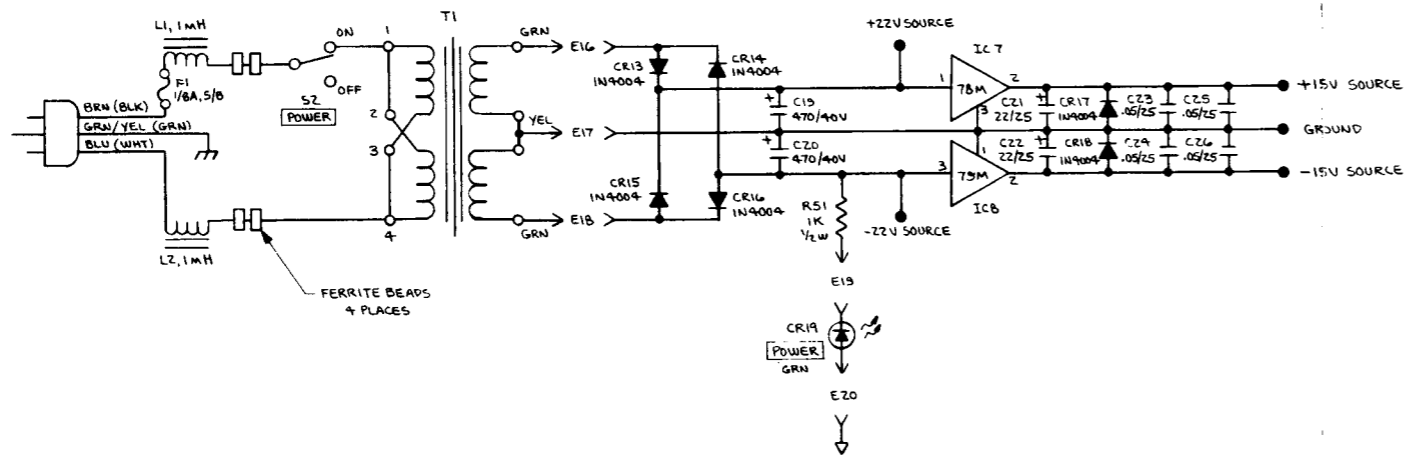
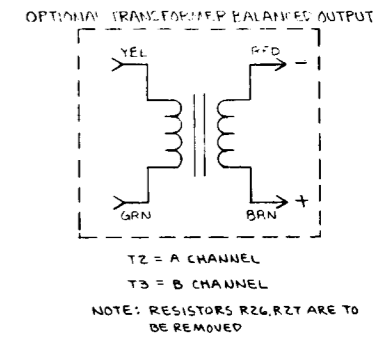
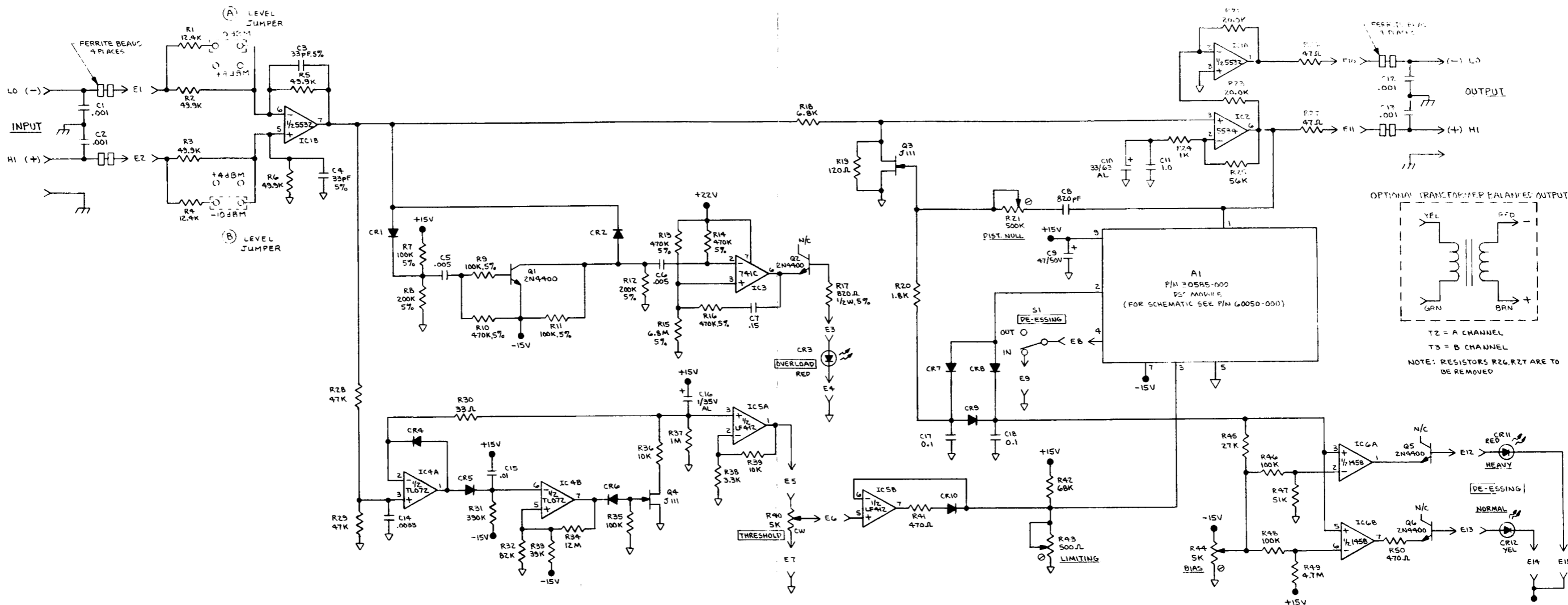

4. ONLY ONE CHANNEL SHOWN. OTHER CHANNEL IS IDENTICAL.
 3. ALL DIODES ARE IN414B.
 2. ALL CAP'S ARE IN MICROFARADS.
 1. ALL RESISTORS ARE 1/8W, 1%, MF. (RN55D)
- NOTES: UNLESS OTHERWISE SPECIFIED

REFERENCE DESIGNATORS		
ITEM	LAST USED	NOT USED
C	26	-
IC	8	-
R	51	-
Q	6	-
CR	19	-
S	2	-
L	2	-
T	3	-

IC POWER & GROUND PINS				
DEVICE	+V	-V	GND	-22V
TLO7Z	8	4	-	-
LF412	8	4	-	-
5532	8	4	-	-
5534	7	4	-	-
1458	-	-	B	4
741C	7	4	-	-

urban a division of AKG Acoustics, Inc.

TITLE: SCHEMATIC
536A DE-ESSER
60070-000-02