

Operating Manual

---

# AM Broadcast Audio Processor

---

Model CAM-1

**orban**<sup>®</sup>

---

**IMPORTANT NOTE:** Refer to the unit's rear panel for your C-Series Model #.

### C-Series Broadcast Processors

<u>Model #:</u>	<u>Description:</u>
CAM-1	1-channel AM Broadcast Processor, 200-260V, Pre-emphasis.
CFM-2	2-channel FM Broadcast Processor, 200-260V, 50 $\mu$ s Pre-emphasis.
CTV-1	1-channel TV Broadcast Processor, 200-260V, 50 $\mu$ s Pre-emphasis.
CTV-2	2-channel TV Broadcast Processor, 200-260V, J.17 Pre-emphasis.

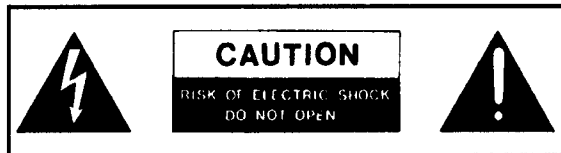

**CAUTION:** TO REDUCE THE RISK OF ELECTRICAL SHOCK, DO NOT REMOVE COVER (OR BACK). NO USER SERVICEABLE PARTS INSIDE. REFER SERVICING TO QUALIFIED SERVICE PERSONNEL.

**WARNING:** TO REDUCE THE RISK OF FIRE OR ELECTRICAL SHOCK, DO NOT EXPOSE THIS APPLIANCE TO RAIN OR MOISTURE.



This symbol, wherever it appears, alerts you to the presence of uninsulated dangerous voltage inside the enclosure — voltage that may be sufficient to constitute a risk of shock.



This symbol, wherever it appears, alerts you to important operating and maintenance instructions in the accompanying literature. Read the manual.

# IMPORTANT SAFETY INSTRUCTIONS

All the safety and operating instructions should be read before the appliance is operated.

**Retain Instructions:** The safety and operation instructions should be retained for future reference.

**Heed Warnings:** All warnings on the appliance and in the operating instructions should be adhered to.

**Follow Instructions:** All operation and user instructions should be followed.

**Water and Moisture:** The appliance should not be used near water (e.g., near a bathtub, washbowl, kitchen sink, laundry tub, in a wet basement, or near a swimming pool, etc.).

**Ventilation:** The appliance should be situated so that its location or position does not interfere with its proper ventilation. For example, the appliance should not be situated on a bed, sofa, rug, or similar surface that may block the ventilation openings; or, placed in a built-in installation, such as a bookcase or cabinet that may impede the flow of air through the ventilation openings.

**Heat:** The appliance should be situated away from heat sources such as radiators, heat registers, stoves, or other appliances (including amplifiers) that produce heat.

**Power Sources:** The appliance should be connected to a power supply only of the type described in the operating instructions or as marked on the appliance.

**Grounding or Polarization:** Precautions should be taken so that the grounding or polarization means of an appliance is not defeated.

**Power-Cord Protection:** Power-supply cords should be routed so that they are not likely to be walked on or pinched by items placed upon or against them, paying particular attention to cords at plugs, convenience receptacles, and the point where they exit from the appliance.

**Cleaning:** The appliance should be cleaned only as recommended by the manufacturer.

**Non-Use Periods:** The power cord of the appliance should be unplugged from the outlet when left unused for a long period of time.

**Object and Liquid Entry:** Care should be taken so that objects do not fall and liquids are not spilled into the enclosure through openings.

**Damage Requiring Service:** The appliance should be serviced by qualified service personnel when:

- The power supply cord or the plug has been damaged; or
- Objects have fallen, or liquid has been spilled into the appliance; or
- The appliance has been exposed to rain; or
- The appliance does not appear to operate normally or exhibits a marked change in performance; or
- The appliance has been dropped, or the enclosure damaged.

**Servicing:** The user should not attempt to service the appliance beyond that described in the operating instructions. All other servicing should be referred to qualified service personnel.

**The Appliance should be used only with a cart or stand that is recommended by the manufacturer.**

## Safety Instructions (European)

### **Notice For U.K. Customers If Your Unit Is Equipped With A Power Cord.**

#### **WARNING: THIS APPLIANCE MUST BE EARTHED.**

The cores in the mains lead are coloured in accordance with the following code:

GREEN and YELLOW - Earth      BLUE - Neutral      BROWN - Live

As colours of the cores in the mains lead of this appliance may not correspond with the coloured markings identifying the terminals in your plug, proceed as follows:

The core which is coloured green and yellow must be connected to the terminal in the plug marked with the letter E, or with the earth symbol, (⌚), or coloured green, or green and yellow.

The core which is coloured blue must be connected to the terminal marked N or coloured black.

The core which is coloured brown must be connected to the terminal marked L or coloured red.



The power cord is terminated in a CEE7/7 plug (Continental Europe). The green/yellow wire is connected directly to the unit's chassis. If you need to change the plug and if you are qualified to do so, refer to the table below.

**WARNING:** If the ground is defeated, certain fault conditions in the unit or in the system to which it is connected can result in full line voltage between chassis and earth ground. Severe injury or death can then result if the chassis and earth ground are touched simultaneously.

CONDUCTOR		WIRE COLOR	
		Normal	Alt
L	LIVE	BROWN	BLACK
N	NEUTRAL	BLUE	WHITE
E	EARTH GND	GREEN-YELLOW	GREEN

### **AC Power Cord Color Coding**

## Safety Instructions (German)

Gerät nur an der am Leistungsschild vermerkten Spannung und Stromart betreiben.

Sicherungen nur durch solche, gleicher Stromstärke und gleichen Abschaltverhaltens ersetzen. Sicherungen nie überbrücken.

Jedwede Beschädigung des Netzkabels vermeiden. Netzkabel nicht knicken oder quetschen. Beim Abziehen des Netzkabels den Stecker und nicht das Kabel erfassen. Beschädigte Netzkabel sofort auswechseln.

Gerät und Netzkabel keinen übertriebenen mechanischen Beanspruchungen aussetzen.

Um Berührung gefährlicher elektrischer Spannungen zu vermeiden, darf das Gerät nicht geöffnet werden. Im Fall von Betriebsstörungen darf das Gerät nur von befugten Servicestellen instandgesetzt werden. Im Gerät befinden sich keine, durch den Benutzer reparierbare Teile.

Zur Vermeidung von elektrischen Schlägen und Feuer ist das Gerät vor Nässe zu schützen. Eindringen von Feuchtigkeit und Flüssigkeiten in das Gerät vermeiden.

Bei Betriebsstörungen bzw. nach Eindringen von Flüssigkeiten oder anderen Gegenständen, das Gerät sofort vom Netz trennen und eine qualifizierte Servicestelle kontaktieren.

## Safety Instructions (French)

On s'assurera toujours que la tension et la nature du courant utilisé correspondent bien à ceux indiqués sur la plaque de l'appareil.

N'utiliser que des fusibles de même intensité et du même principe de mise hors circuit que les fusibles d'origine. Ne jamais shunter les fusibles.

Eviter tout ce qui risque d'endommager le câble secour. On ne devra ni le plier, ni l'aplatir. Lorsqu'on débranche l'appareil, tirer la fiche et non le câble. Si un câble est endommagé, le remplacer immédiatement.

Ne jamais exposer l'appareil ou le câble à une contrainte mécanique excessive.

Pour éviter tout contact avec une tension électrique dangereuse, on n'ouvrira jamais l'appareil. En cas de dysfonctionnement, l'appareil ne peut être réparé que dans un atelier autorisé. Aucun élément de cet appareil ne peut être réparé par l'utilisateur.

Pour éviter les risques de décharge électrique et d'incendie, protéger l'appareil de l'humidité. Eviter toute pénétration d'humidité ou fr liquide dans l'appareil.

En cas de dysfonctionnement ou si un liquide ou tout autre objet a pénétré dans l'appareil couper aussitôt l'appareil de son alimentation et s'adresser à un point de service après-vente autorisé.

## Safety Instructions (Spanish)

Hacer funcionar el aparato sólo con la tensión y clase de corriente señaladas en la placa indicadora de características.

Reemplazar los fusibles sólo por otros de la misma intensidad de corriente y sistema de desconexión. No poner nunca los fusibles en puente.

Proteger el cable de alimentación contra toda clase de daños. No doblar o apretar el cable. Al desenchufar, asir el enchufe y no el cable. Sustituir inmediatamente cables dañados.

No someter el aparato y el cable de alimentación a esfuerzo mecánico excesivo.

Para evitar el contacto con tensiones eléctricas peligrosas, el aparato no debe abrirse. En caso de producirse fallos de funcionamiento, debe ser reparado sólo por talleres de servicio autorizados. En el aparato no se encuentra ninguna pieza que pudiera ser reparada por el usuario.

Para evitar descargas eléctricas e incendios, el aparato debe protegerse contra la humedad, impidiendo que penetren ésta o líquidos en el mismo.

En caso de producirse fallas de funcionamiento como consecuencia de la penetración de líquidos u otros objetos en el aparato, hay que desconectarlo inmediatamente de la red y ponerse en contacto con un taller de servicio autorizado.

## Safety Instructions (Italian)

Far funzionare l'apparecchio solo con la tensione e il tipo di corrente indicati sulla targa riportante i dati sulle prestazioni.

Sostituire i dispositivi di protezione (valvole, fusibili ecc.) solo con dispositivi aventi lo stesso amperaggio e lo stesso comportamento di interruzione. Non cavallottare mai i dispositivi di protezione.

Evitare qualsiasi danno al cavo di collegamento alla rete. Non piegare o schiacciare il cavo. Per staccare il cavo, tirare la presa e mai il cavo. Sostituire subito i cavi danneggiati.

Non esporre l'apparecchio e il cavo ad esagerate sollecitazioni meccaniche.

Per evitare il contatto con le tensioni elettriche pericolose, l'apparecchio non deve venir aperto. In caso di anomalie di funzionamento l'apparecchio deve venir riparato solo da centri di servizio autorizzati. Nell'apparecchio non si trovano parti che possano essere riparate dall'utente.

Per evitare scosse elettriche o incendi, l'apparecchio va protetto dall'umidità. Evitare che umidità o liquidi entrino nell'apparecchio.

In caso di anomalie di funzionamento rispettivamente dopo la penetrazione di liquidi o oggetti nell'apparecchio, staccare immediatamente l'apparecchio dalla rete e contattare un centro di servizio qualificato.

Operating Manual

---

# AM Broadcast Processor

---

Model CAM-1

**orban**<sup>®</sup>

CAM-1 is protected by U.S. patents 4,249,042; 4,208,548; 4,460,871; and U.K. patent 2,001,495.  
Other patents pending.

Orban is a registered trademark.

This manual is part number 96076-000-01  
50 - KC - 2/97

© Copyright 1997

**orban**

**H** A Harman International Company

1525 Alvarado Street, San Leandro, CA 94577 USA • Phone (1) 510/351-3500 • Fax: (1) 510/351-0500

# Orban CAM-1

---

# AM Broadcast Processor

---

# Operating Manual

page	contents
1-1	<b>Section 1: Introduction</b> Orban CAM-1 AM Broadcast Audio Processor
2-1	<b>Section 2: Installation</b> Installation Grounding
3-1	<b>Section 3: Operation</b> CAM-1 Controls and Meters Setting Up the CAM-1 AM Broadcast Audio Processor Fundamentals of Broadcast Audio Processing Block Diagram
4-1	<b>Section 4: Maintenance</b> Routine Maintenance Getting Inside the Chassis Performance Evaluation, Alignment
5-1	<b>Section 5: Troubleshooting</b> Problems and Possible Causes Troubleshooting IC Opamps Technical Support Factory Service Shipping Instructions
6-1	<b>Section 6: Technical Data</b> Specifications Circuit Description Parts List Schematics, Assembly Drawings Abbreviations

# Index

## A

abbreviations 6-39  
assembly drawings 6-30  
audible distortion 5-3

## B

block diagram 6-31  
buzzes 5-2

## C

chassis ground 2-4  
chassis, getting inside 4-2  
circuit boards  
    access to 4-2  
    front panel 4-2  
circuit description 6-4  
circuit ground 2-4  
clicks 5-2  
common-mode rejection 2-4  
control settings 3-4  
controls 3-2  
covers, removing/replacing 4-2

## D

dBm (definition) 6-39  
dBu (definition) 6-39  
distortion 5-3  
dull sound 5-3

## F

factory service 5-5  
front panel 1-2, 3-2  
fuse 6-3

## G

gain reduction 3-3  
    meter 3-3  
gating 6-9  
    control circuits 4-5  
grounding 2-4, 5-2  
    difficult situations 2-5  
    ground loop 2-5

## H

harshness 5-3  
high-frequency  
    limiter 6-11  
hum 5-2

## I

input  
    attenuation 6-6  
    stages 4-5  
input buffer 6-6

## J

jumpers  
    access to 4-2

## L

limiting 6-7 - 6-8, 6-10 - 6-11

## M

maintenance, routine 4-2  
meters 6-10

## O

options  
    jumpers 2-2  
ordering parts 6-22  
output  
    stages 4-5  
overshoot 5-2

## P

packing for shipment 5-5  
parts list 6-21  
peak  
    control 5-2  
performance evaluation 4-4  
phase rotator 6-7  
physical dimensions 6-3  
power  
    requirements 6-3  
    supplies 4-4 - 4-5, 5-2, 6-20  
pre-emphasis 6-11  
problems 5-2

## R

rack-mounting unit 2-3  
rear panel 1-2  
return authorization 5-5  
RF suppression 5-2  
ringing 5-2

## S

schematics 6-30  
service 5-5  
set-up 3-4  
shipping  
    damage 2-2  
    instructions 5-5  
shrillness 5-3  
Smart Clipper 6-12  
    voltage-controlled amplifier 6-16  
specifications 6-2

## T

technical support 5-4  
test mode 3-3  
tilt 5-3  
troubleshooting 5-1

## V

VCAs 4-5  
vendor codes 6-29  
voltage regulators 5-2



# Section 1

# Introduction

page      contents

---

1-3	<b>Orban CAM-1 AM Broadcast Audio Processor</b>
1-3	CAM-1 Performance Highlights
1-4	Related Orban Processors

Figure 1-1: Front and Rear Panels

## Orban CAM-1 AM Broadcast Audio Processor

The world's successful AM broadcast stations all use audio processing to produce a sound on the air that attracts listeners. CAM-1 has been designed specifically with this in mind, to produce improved sound for a wide range of AM broadcast material.

Orban's CAM-1 improves the sound quality of AM broadcasting by providing increased high frequencies and improved bass. It can make your station louder, so its coverage will be increased.

CAM-1 produces a very easy-to-listen-to sound. Your station will sound better to listeners. Your levels will stay consistent, so that the listener will not need to change the volume control on their radio as you change from music to voice, from one program to another.

CAM-1 works best when connected directly to the transmitter. It prevents the transmitter from over-modulating, taking over the function of a limiter, but without introducing the distortions typical of peak limiters.

CAM-1 is easy to install and adjust. The only operating controls are input and output level. Orban's engineers spent hundreds of hours listening and adjusting, to set the processing's parameters to work well with all kinds of program material.

The CAM-1 provides level control, dual-band AGC and compression, high-frequency boost (AM pre-emphasis) to help overcome the severe high frequency rolloffs in radios, bandwidth limiting to 9kHz, and final absolute peak control to prevent over-modulation by the transmitter.

### CAM-1 Performance Highlights

- Replaces all on-line compressors and limiters.
- Accurately and transparently **limits levels** without producing audible artifacts.
- Keeps a consistent loudness on the air with changes in input level.
- Has very low static and dynamic distortion, thus producing **extremely transparent, natural audio quality**.
- **Limits its output bandwidth** to 9kHz while constraining overshoots at its output to approximately 1dB maximum.
- Accurately indicates processing with a 10-element LED bargraph array.
- Uses a **transformerless, balanced 10k $\Omega$  instrumentation-amplifier input and a transformerless, balanced, floating 30 $\Omega$  output** to ensure highest transparency and accurate pulse response.
- Designed to meet all applicable **international safety standards**.
- Designed and built in the United States by Orban, manufacturer of the world-famous OPTIMOD<sup>®</sup> processors.

### **Related Orban Processors**

Orban also offers the OPTIMOD-AM 9100B Audio Processor, for mono or C-QUAM stereo. This unit produces a louder and brighter sound on the air than the CAM-1, and also offers a wide range of control to customize your sound. It can also compensate for imperfections in transmitter square wave response.

The CAM-1 is designed for AM mono. AM stereo requires special processing to meet the requirements of the C-QUAM AM Stereo standard. For AM Stereo, use the Orban OPTIMOD-AM 9100B2.

# Section 2

# Installation

page	contents
2-2	<b>Installation</b>
2-2	Figure 2-1: Jumper Locations
2-3	Figure 2-2: Rear Panel Audio Connections
2-4	<b>Grounding</b>
2-4	Power Ground
2-5	Difficult Situations



**CAUTION**

The installation and servicing instructions in this manual are for use by qualified personnel only. To avoid electric shock, do not perform any servicing other than that contained in the Operating Instructions unless you are qualified to do so. Refer all servicing to qualified service personnel.

# Installation

Allow about 30 minutes for installation.

Installation consists of (1) unpacking and inspecting the CAM-1, (2) optional resetting of the input sensitivity, (3) mounting the CAM-1, and (4) connecting audio and power.

## 1. Unpack and inspect.

If you note obvious physical damage, contact the carrier immediately to make a damage claim.

- If you should ever have to ship the CAM-1 (e.g., for servicing), it is best to ship it in the original packing materials because these have been carefully designed to protect the unit. *Save all packing materials.*

Packed with the CAM-1 are:

- 1 - Operating Manual (includes Registration Card)
- 1 - Power Cord
- 1 - Adjustment Tool (to adjust front panel input and output controls)

## 2. Set input sensitivity jumpers. (optional)

*[Skip this step if you want -10dBu to +10dBu input sensitivity.]*

The CAM-1 is shipped with a 20dB pad ahead of its instrumentation-amplifier input buffer. This is suitable for nominal input levels from -10dBu to +10dBu. If lower input levels (-30dBu to -10dBu) are used, defeat the pad by setting jumper JH1 and jumper JH2 to the 0dB level position. See Figure 2-1 to locate and set jumpers JH1 and JH2.

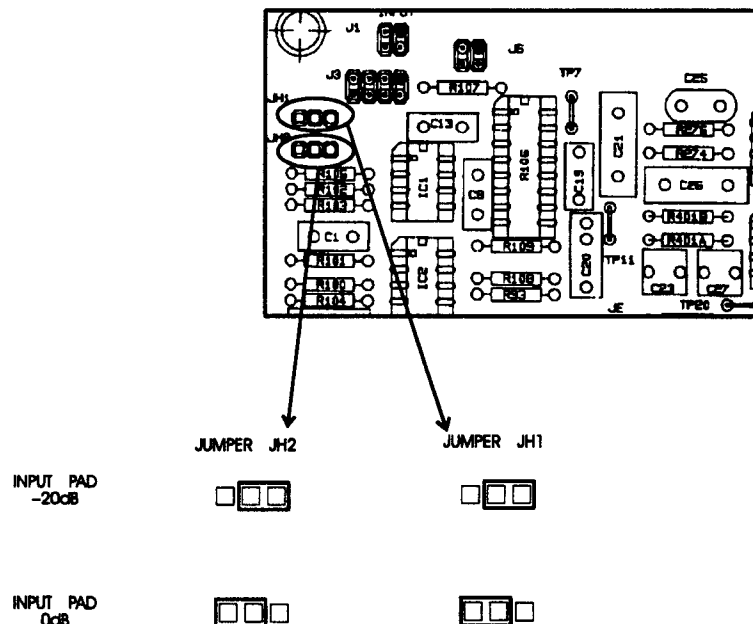

Figure 2-1: Jumper Locations

See Figure 2-1 to locate and set jumpers JH1 and JH2.

To reset the jumpers, you will need to remove the top cover to access the main circuit board. Do this by removing all screws holding the cover in place. Then lift the cover off.

Be sure power is disconnected before removing covers.

When replacing the cover, replace all screws snugly. Be careful not to strip the threads by fastening the screws too tightly.



### 3. Mount the CAM-1 in a rack.

The single channel CAM-1 requires one standard rack unit (1.75 inches, 4.4 cm).

There should be a good ground connection between the rack and the CAM-1 chassis — check this with an ohmmeter.

Mounting the unit over large heat-producing devices (such as a vacuum-tube power amplifier) may shorten component life and is not recommended. Ambient temperature should not exceed 113°F (45°C) when equipment is powered.

### 4. Connect audio input and output.

Refer to Figure 2-2 and connect the Source device to CAM-1's Input jack and CAM-1's Output jack to the Load (Transmitter).

We recommend using **two-conductor shielded cable** (such as Belden 8451 or equivalent), because signal current flows through the two conductors only. The shield does not carry signal, is used only for shielding, and is ordinarily connected to ground at one end only.

**Input and output connectors are XLR-type connectors.**

In the XLR-type connectors, pin 1 is CHASSIS GROUND, while pin 2 and pin 3 are a balanced, floating pair. This wiring scheme is compatible with *any* studio wiring standard: If one pin is considered LOW, the other pin is automatically HIGH. If inputs and outputs are wired consistently, the polarity will be overall non-inverting from input to output regardless of which pin is arbitrarily called low and which is called high.

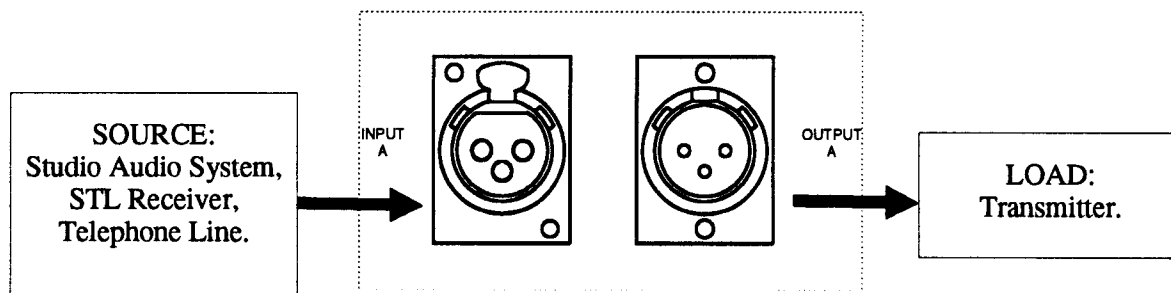

Figure 2-2: Rear Panel Audio Connections

**5. Connect power cord.**

Connect the CAM-1's power cord to an appropriate AC power source.

**6. Complete the Registration Card and return it to Orban (please)**

The Registration Card enables us to inform you of new applications, performance improvements, and service aids that may be developed, and it helps us respond promptly to claims under warranty without having to request a copy of your bill of sales or other proof of purchase. Please fill in the Registration Card and send it to us today.

We do not sell our customer's names to advertising agencies.

## Grounding

Very often, grounding is approached in a "hit or miss" manner. But with care it is possible to wire an audio studio so that it provides maximum protection from power faults and is free from ground loops (which induce hum and can cause oscillation). In an ideal system:

- All units in the system should have *balanced inputs*. In a modern system with low output impedances and high input impedances, a balanced input will provide common-mode rejection and prevent ground loops regardless of whether it is driven from a balanced or unbalanced source. (The CAM-1 has balanced inputs.)
- All equipment *circuit grounds* must be connected to each other; all equipment *chassis grounds* must be connected together.
- *Cable shields* should be connected at one end only, preferably the source (output) end.

**Power Ground**

- Ground the CAM-1 chassis through the third wire in the power cord. Proper grounding techniques *never* leave equipment chassis unconnected to power/earth ground. *A proper power ground is essential to safe operation.* Lifting a chassis from power ground creates a potential safety hazard.



## Difficult Situations

There are no universal wiring techniques because it is not always possible to determine if the equipment driving or being driven by the CAM-1 has its circuit ground internally connected to its chassis ground (which is always connected to the ground prong of the AC power cord, if present), and because the use of the AC power ground often introduces noise or other imperfections such as RFI, hum, clicks, and buzzes.

If hum or noise appears, don't be afraid to experiment. If the noise sounds like a low-level crackling buzz, then probably there isn't *enough* grounding. Try connecting the LOW pin on the CAM-1's input XLR-type connector to a chassis ground terminal or pin 1 on the XLR-type connector and see if the buzz goes away. Either pin 3 or pin 2 will work as the LOW pin; the choice depends only on your organization's standards.

A ground loop usually causes a smooth, steady hum rather than a crackly buzz. If you have a ground loop, think carefully about what is going on, and keep in mind the general principle: one and only one circuit ground path should exist between each piece of equipment!

**This Page Intentionally Left Blank.**

# Section 3

# Operation

<u>page</u>	<u>contents</u>
3-2	CAM-1 Controls and Meters
3-4	Setting Up the CAM-1 AM Broadcast Audio Processor
3-5	Fundamentals of Broadcast Audio Processing
3-5	Level Control
3-5	Absolute Peak Control
3-5	Creating a Louder Sound
3-6	Block Diagram
3-6	Input Conditioning Filter
3-6	AGC Compressor (Gain Reduction)
3-6	High-Frequency Pre-Emphasis and Limiter
3-6	Low-Pass Filter
3-6	Final Peak Controller



### Caution

The installation and servicing instructions in this manual are for use by qualified personnel only. To avoid electric shock do not perform any servicing other than that contained in the Operating Instructions unless you are qualified to do so. Refer all servicing to qualified service personnel.

## CAM-1 Controls and Meters

**Note:** Use the Orban adjustment tool, supplied with this unit, to adjust the Input and Output controls.

**INPUT** determines the amount of limiting by adjusting the drive level into the limiter. The range of the INPUT control can be changed 20dB by resetting jumpers inside the unit — see step 2 on page 2-2.

**OUTPUT** determines the level appearing at the CAM-1's output. Maximum peak level is approximately +23dBm/600Ω.

**LIMITING** is a ten-segment LED meter that indicates the amount of limiting (gain reduction) in dB that is occurring in the dual-band limiter. The meter's range is 25 to 2.5dB in 2.5dB steps. It is important to operate the CAM-1 so that the red 25dB lamp never lights.

**GATED light** indicates that the compressor gate in the dual-band limiter has "frozen" the gain of the dual-band limiter to prevent noise breathing during low-level program material or silence.

**HF LIMITER light** indicates that the high-frequency limiter is dynamically low-pass filtering the program material to eliminate pre-emphasis-induced overload.

## Setting Up the CAM-1 AM Broadcast Audio Processor

1. Set the CAM-1's INPUT and OUTPUT controls using program material.
  - A  Set the OUTPUT control fully counter-clockwise.
  - B  Apply program material at normal levels.
  - C  Adjust the INPUT control until you see 10dB to 15dB of gain reduction on the LIMITING meter.
  - D  Advance the OUTPUT control clockwise until the transmitter is modulating slightly below 100% on peaks.
  - E  Observe with different types of program material, and adjust for "worst case."

## **Fundamentals of Broadcast Audio Processing**

### **Level Control**

A broadcast audio processor must accept input signals over a wide range — typically 25dB — and control the output level to keep a reasonably constant average level on the air. It must do so effectively on all voice and all music, without requiring readjustment.

Typical studio compressors are not effective for broadcast level control. They have many controls that need to be readjusted to sound best on each song or each voice. Poorer designs also add distortions such as “pumping.”

### **Absolute Peak Control**

A broadcast audio processor controls the absolute peak level of the signal so that the signal will never over-modulate the transmitter. In AM (LW, MW and HF) broadcasting, negative over-modulation results in high audible distortion, and possible damage to the transmitter.

Typical “peak limiters” not specifically designed for broadcast are not effective at absolute peak control; they have significant overshoots. They also add noticeable distortion to the sound. A broadcast audio processor must control not only the peaks, but must also limit the bandwidth.

### **Creating a Louder Sound**

By using an Orban Audio Processor, a station will be much louder, clearer and better sounding than a station using a simple compressor/limiter. The station with Orban will attract and keep listeners.

## Block Diagram

### Input Conditioning Filter

The peaks on human voice are not symmetrical. This means that the peaks in one direction (positive or negative) will be much higher in level than the peaks in the other direction.

An all-pass filter makes the peaks symmetrical. This prevents audible distortion in the processing, and it guarantees that the loudness of voice matches the loudness of music.

### AGC Compressor (Gain Reduction)

A two-band gated AGC and compressor divides the audio into two bands (below 150Hz and above 150Hz)

Two-band processing gives a sound that is much more natural than wide-band processing, since the bass level does not interfere with the midrange. It also automatically rebalances the bass-to-midrange level for a more natural sound.

Gating prevents the compressor from pulling up noise during quiet passages.

### High-Frequency Pre-Emphasis and Limiter

A special Pre-Emphasis is used to overcome the severe high-frequency rolloff in typical AM radios. This starts boosting at approximately 1kHz, and is up approximately 10dB at 9kHz.

The High-Frequency Limiter prevents high-frequency peaks boosted by the pre-emphasis from causing over-modulation of the transmitter.

### Low-Pass Filter

The Low-Pass Filter cuts off the high frequencies to keep the bandwidth within official requirements.

The control of bandwidth before the final peak control greatly reduces the problem of overshoots caused by filters in the transmitter.

### Final Peak Controller

Final Peak Control without causing audible distortion, pumping, or loss of loudness is the specialty of Orban processing.

Peaks are controlled not with peak limiting (which causes all of the above problems), but with distortion-canceling clippers. Peaks are clipped at 100% modulation, then the distortion caused by the clipping is canceled by a series of precisely-designed circuits unique to Orban processors.



# Section 4

# Maintenance

<u>page</u>	<u>contents</u>
4-2	Routine Maintenance
4-2	Getting Inside the Chassis
4-4	Performance Evaluation, Alignment
4-12	Figure 4-1: Limiting Curves



### **CAUTION**

The installation and servicing instructions in this manual are for use by qualified personnel only. To avoid electric shock do not perform any servicing other than that contained in the Operating Instructions unless you are qualified to do so. Refer all servicing to qualified service personnel.

## Routine Maintenance

No routine maintenance of this product is required.

If the front panel becomes soiled, clean it with a mild household detergent and a damp cloth. Stronger solvents should not be used because they may damage plastic parts, paint, or the silk-screened lettering (99% isopropyl alcohol can be safely used).

## Getting Inside the Chassis

To access the circuit boards, begin by removing all 10 screws holding the top cover in place, and lift the top cover off. When replacing the covers, replace all screws snugly (be careful not to strip the threads by fastening the screws too tightly).



Be sure power is disconnected before removing the covers.

### 1. Removing the main circuit board.

If you want to replace any soldered-in component, you must remove its associated circuit board to gain access to the board's solder side.

- a  The main circuit board is connected to the display board, the power supply, and the rear panel connectors through various jacks that mate with plug-terminated cables. Unplug all cables from the board, noting where they go for reassembly later.
- b  Remove the five screws securing the board to its mounting standoffs.
- c  Carefully lift the board out of the chassis.

To reassemble, follow the above directions in reverse. Be careful to replace the retaining clips on the DIP plugs.

### 2. Accessing the Display Board

- a  To remove the front panel, remove the small black screw in the center of the panel with a  $\frac{1}{16}$  inch hex wrench. Remove the four large black screws on its four corners with a  $\frac{3}{32}$  inch hex wrench. Then pull the front panel toward you.

Take care not to cosmetically damage the LED meter assemblies by scraping them with the panel.

The display board is now revealed. Its components are mounted on the back of the board.

- b  To access the components, remove the eight screws holding the display board on its supporting stand-off posts.

- c  *Very slowly and carefully* tilt the board down toward you, imagining a hinge on its bottom edge.

The ribbon cables connecting the display board to the main board are easily damaged by excessive tension or flexing. **Treat them gently!**

### 3. Reassembling the Display Board and Front Panel

- A  *Very slowly and carefully* tilt the board up and align the mounting holes with the stand-off posts.
- B  Start, but do not tighten, all eight screws holding the display board on its supporting stand-off posts.
- C  Carefully center the board.
  - If you neglect this step, the LED meter assemblies or the switches may bind against the front panel after it is replaced.
- D  “Thread” the switches and LED displays through their associated holes in the front panel.
- E  Center the panel on its stand-offs, and replace the five hex screws removed in step 2-A above.

If any components bind against the panel, you may have to re-center the circuit board per step 3-C above.

## Performance Evaluation, Alignment

**IMPORTANT:** Because the CAM-1 circuitry is highly stable, routine performance evaluation and alignment are *not* required and *not* recommended. The following evaluation procedure is extremely thorough, and is included primarily for reference.

### Equipment Required:

#### Oscilloscope

DC-coupled with at least 5MHz vertical bandwidth.

#### Digital Voltmeter

Accurate to 0.1%

#### Audio Voltmeter

Accurate to 2%. Sound Technology 1710B or equivalent preferred.

#### Low-Distortion Audio Oscillator

With verified residual distortion below 0.003%.  
Sound Technology 1710B or equivalent preferred.

#### THD Analyzer

With verified residual distortion below 0.003%.  
Sound Technology 1710B or equivalent preferred.

#### Spectrum Analyzer with tracking generator

Tektronix 5L4N plug-in with 5111 bistable storage mainframe, or equivalent. *Alternatively*, an FFT analyzer (HP 3561A or equivalent) can be used, although most FFT-based analyzers update slowly and thus make the interactive adjustments described below more difficult.



### **CAUTION**

The installation and servicing instructions in this manual are for use by qualified personnel only. To avoid electric shock do not perform any servicing other than that contained in the Operating Instructions unless you are qualified to do so. Refer all servicing to qualified service personnel.

These are instructions for thoroughly checking the performance of the CAM. The evaluation includes checks of the power supplies, input stages, VCAs, gate control circuits, VCA control circuits, meters, high-frequency limiters, clippers, output stages, and overall performance. This procedure is useful in diagnosing and detecting problems, as well as for checking routine performance.

See the assembly drawings in **Section 6** for the locations of components, jumpers, and test points. *All jumpers and test points are located on the main circuit board.*

Perform procedures in order without skipping steps.

### 1. Prepare the unit.

- Record the settings of the jumpers so you can restore them after you have finished the alignment procedure.
- Set the jumpers on the board as follows:

#### Jumper Positions

Jumpers	Setting	Notes
JH1 + 2	-20dB	input sensitivity
JD	PRE-EMPH.	

The CAM-1 is shipped with a 20dB pad ahead of its instrumentation-amplifier input buffer. If jumpers JH1 and JH2 have been reset to the 0dB level position, to defeat the pad in order to work with lower input levels (-30dBu to -10dBu), you need to reset the jumpers to their default position. Refer to the Main Assembly Drawing in Section 6 to locate and set the jumpers accordingly.

The CAM-1 is shipped from the factory configured for pre-emphasized response. Verify that jumper JD is set to PRE-EMPH. Refer to the Main Assembly Drawing in Section 6 to locate and set the jumper accordingly.

### 2. Test power transformer; POWER switch; fuse; associated wiring. (optional)

- Verify that the resistance between the AC cord ground pin and the chassis is close to 0Ω.
- Verify that the resistance between both AC cord blades and the chassis is infinite.  
Verify that the resistance between the AC cord blades is  $100\Omega \pm 10\%$ .  
Be sure that the correct 1/4-amp fuse is installed.



### 3. Test the unregulated power supply.

- Connect the CAM-1 to a source of mains power.

- ▣ Measure the voltage of the positive unregulated power supply.  
The voltage must be between +18 and +26 volts. It is typically +22V, but this will vary widely with changes in line voltage.  
This voltage is measured across large electrolytic capacitor C425.
- ▣ Measure the voltage of the negative unregulated power supply.  
The voltage must be between -18 and -26 volts. It is typically -22V, but this will vary widely with changes in line voltage.  
This voltage is measured across large electrolytic capacitor C426.

#### 4. Test the regulated power supply.

- ▣ Measure the output of the +15 volt regulator (at the (+) terminal of C1).  
The voltage must be +15 volts,  $\pm 0.75V$ . If it is not, see the power supply troubleshooting information on page 5-2.
- ▣ Measure the output of the -15 volt regulator (at the (-) terminal of C2).  
The voltage must be -15 volts,  $\pm 0.75V$ . If it is not, see the power supply troubleshooting information on page 5-2.
- ▣ Observe the regulated power supply rails with an oscilloscope.  
Verify that the total noise and ripple is below 4mV peak.
- ▣ Measure the output of the +5.8 volt source (at TP9).  
The voltage must be +5.8 volts,  $\pm 0.5V$ .
- ▣ Measure the output of the -5.8 volt source (at TP12).  
The voltage must be -5.8 volts,  $\pm 0.5V$ .
- ▣ Measure the output of the +1.9 volt source (at TP13).  
The voltage must be +1.9 volts,  $\pm 0.2V$ .
- ▣ Measure the output of the -1.9 volt source (at TP14).  
The voltage must be -1.9 volts,  $\pm 0.2V$ .
- ▣ Verify that the OPERATE LED is lit.
- ▣ Measure the output of the (+) clip level source (at TP15).  
The voltage must be +5.0 volts,  $\pm 0.2V$ . If the level is incorrect, adjust R167 (Clip level set).
- ▣ Measure the output of the (-) clip level source (at TP18).  
The voltage must be -5.0 volts,  $\pm 0.2V$ .
- ▣ Force the CAM-1 into TEST mode by momentarily connecting the anode of CR38 to the -15 volt power supply, using a jumper lead.  
The anode lead of the diode is the lead opposite the diode's banded end.  
TP6 is a convenient source of -15 volts.

- c  Mute the oscillator by turning down its OUTPUT LEVEL control.  
Verify that the GATED lamp on the CAM-1's front panel lights.
- d  Using its OUTPUT LEVEL control, increase the audio oscillator's output level until the GATED lamp goes out. Verify that this occurs when the level at TP8 is  $-7\text{dBu}$  ( $109\text{mV}$ )  $\pm 4\text{dB}$ .

The audio voltmeter should still be connected to TP8.

## 7. Check VCA control circuits and LIMITING meters.

- a  Observe the CAM-1's audio output with the voltmeter.
- b  Mute the oscillator.
- c  Activate the CAM-1's reference-level oscillator by momentarily connecting pin 5 of IC43 to the  $-15$  volt power supply, using a jumper lead.  
This forces the CAM-1 to produce a 400Hz tone whose peak level is equal to 100% modulation.  
Be very careful not to accidentally touch pin 4 of IC43 with the jumper lead; this can destroy IC43! Instead of pin 5 of IC43, you can touch the jumper lead to the side of R445 not connected to ground. However, be sure you do not connect the  $-15$  volt supply to ground by touching the wrong lead of R445!
- d  Set the CAM-1's OUTPUT LEVEL control so that the voltmeter indicates  $+10\text{dBu}$  ( $2.449\text{V}$ ).
- e  Force the CAM-1 into OPERATE mode by momentarily connecting the anode of CR32 to the  $-15$  volt power supply, using a jumper lead.
- f  Set the oscillator's output level to  $+10\text{dBu}$  at 5kHz.
- g  Set the CAM-1's INPUT LEVEL control fully clockwise.
- h  Verify that all LED segments of the LIMITING meter light.
- i  Quickly reduce the oscillator's output level to  $-25\text{dBu}$ . Verify that the LIMITING meter reading decays to 5dB in 4.7 seconds  $\pm 1$  seconds.
- j  Adjust the oscillator's output level control so that the second (5dB) LED segment of the LIMITING meter just lights, but the third segment does not.
- k  Connect the audio voltmeter to TP8, and observe the level there.
- l  Increase the audio oscillator's output level by  $+17.5\text{dB}$ .
- m  Verify that the LIMITING meter indicates 22.5dB limiting, and that the level at TP8 is no more than 1.0dB greater than the level observed before increasing the oscillator's output level.

**8. Test the common mode rejection.**

- A  Force the CAM-1 into TEST mode by momentarily connecting the anode of CR38 to the -15 volt power supply, using a jumper lead.  
Verify that the TEST lamp is lit.
- B  Set the oscillator for 100Hz and reduce its output level by 10dB.  
The oscillator should be connected to the CAM-1's input.
- C  Measure the level at the CAM-1's output with the audio voltmeter.
- D  Remove the ground from the (-) input.
- E  Connect the signal to both the (+) and (-) inputs in parallel.
- F  Verify that the output level is reduced by at least 50dB.
- G  Remove the signal from the (-) input and replace the ground.

**9. Align Smart Clipper.**

- A  Place jumper J1 in the IN position.  
Refer to the Main Assembly Drawing in Section 6 to locate and set the jumper accordingly.
- B  Disconnect the oscillator from the CAM-1 input, and connect it to TP17.  
This injects the oscillator output directly into the "Smart Clipper" circuit.  
  
See the main board Assembly Drawing in Section 6 to locate this IC and any other components called out in the procedure below.
- C  Connect the input of the audio voltmeter/THD Analyzer to TP11.
- D  Verify that the TEST lamp is lit.  
If it is not, force the CAM-1 into TEST mode by momentarily connecting the anode of CR38 to the -15 volt power supply, using a jumper lead.
- E  Set the oscillator frequency to 5kHz.
- F  Adjust the oscillator output level to produce +10dBu (2.45Vrms) at TP11.
- G  Set the oscillator frequency to 50Hz.  
Be sure that the output level of the oscillator did not change when you changed frequency.
- H  Adjust R298 (LF BALANCE) to produce +10dBu (2.45Vrms) at TP11.  
This produces flat response from the Smart Clipper circuit.
- I  Set the oscillator to 400Hz.



- J  Adjust the oscillator level so that the level appearing at the CAM-1's output is about 7 volts.
- K  Connect the oscilloscope to pin 1 of IC27.
- L  Adjust R92 and R87 (RECTIFIER FEEDTHROUGH NULL) to minimize the level of the signal observed.
- M  Measure the harmonic distortion, and null it with R309 (LF DISTORTION NULL).
- N  Connect the audio voltmeter to TP17.
- O  Set the oscillator frequency to 500Hz. Set its output level to +7dBu (1.73Vrms).
- P  Connect the oscillator to TP19.  
 This modulates the gain of the low-frequency VCA IC25 and associated components at a 500Hz rate.
- Q  Increase the sensitivity of the audio voltmeter monitoring TP11 until the 500Hz feedthrough can be seen easily.  
 It may be useful to observe the audio voltmeter's monitor output with an oscilloscope to verify that you are seeing the feedthrough and not hum or noise. If high- and low-pass filters are available on your audio voltmeter/distortion analyzer, activate them to minimize the effects of hum and high frequency noise upon the measurement.
- R  Null the feedthrough with R301 (LF FEEDTHROUGH NULL).

## 10. Check high-frequency limiters.

- A  Connect the high side of the oscillator to the CAM-1 (+) input.
- B  Connect the low side of the oscillator to the CAM-1 (-) input.
- C  Set the oscillator's frequency to 10kHz and its output level to 0dBu.
- D  Set controls, trimmers, and jumpers as follows:

### Control Settings

Control	Setting
HF LIMITER DIST NULL TRIMMER R269	CENTER
FET BIAS TRIMMER R223	FULLY CLOCKWISE
JUMPER JD	FLAT
MODE	TEST

The CAM-1 is shipped from the factory configured for pre-emphasized response. Reset jumper JD to the FLAT position. Refer to the Main Assembly Drawing in Section 6 to locate and set jumper JD accordingly.

- E  Verify that the TEST lamp is lit.

If it is not, force the CAM-1 into TEST mode by momentarily connecting the anode of CR38 to the -15 volt power supply, using a jumper lead.

- F  Connect a THD analyzer/audio voltmeter and oscilloscope to TP18.
- G  Adjust the input level to produce a level of +14.0dBu  $\pm$ 0.5dB at TP18.
- H  Verify that the signal at TP18 is a sine wave of normal appearance.
- I  Mute the oscillator, verify that there is no "popcorn" noise or oscillation, then restore the signal.
- J  Slowly turn FET BIAS trimmer R223 counterclockwise until the level at TP18 decreases to +11dBu  $\pm$ 0.5dB.
- K  Adjust HF LIMITER DIST NULL trimmer R269 for minimum THD. Verify that THD does not exceed 0.06% in a 20-20,000Hz bandwidth at TP18.
- L  Turn R223 clockwise until the level at TP18 stops increasing. Turn R223 clockwise about  $\frac{1}{10}$ -turn further.
- M  Force the CAM-1 into OPERATE mode by momentarily connecting the anode of CR32 to the -15 volt power supply, using a jumper lead.  
Verify that the OPERATE lamp is lit.
- N  Increase the oscillator's output level until the HF LIMIT lamp lights.
- O  Set the oscillator's frequency to 1kHz, and verify that the HF LIMIT indicator does not light.
- P  Set the oscillator's frequency to 10kHz, and verify that the HF LIMIT indicator lights.

#### 11. Measure frequency response.

- A  Disconnect the audio oscillator from the CAM-1.
- B  Connect the tracking generator output of the spectrum analyzer to pin 2 of the CAM-1 input XLR-type connector (ground pin 3).
- C  Set the spectrum analyzer for a 20-20,000Hz log sweep and a 2dB/division display.
- D  "Freeze" the sweep and manually set it to 1kHz,
- E  Adjust the generator's output level 22dB below the level that causes the 2.5dB lamp (first segment) on the CAM-1's LIMITING meter to light.
- F  Restore the automatic 20-20kHz sweep.
- G  Connect the spectrum analyzer's input to the output of the CAM-1.
- H  Verify a flat response ( $\pm$ 0.5dB).

You should see an abrupt high-frequency cutoff at 9kHz caused by the system low-pass filters.

- Increase the generator's output level by 20dB.

This should be 2dB below the level that causes the 2.5dB lamp (first segment) on the CAM-1's LIMITING meter to light.

- Verify that the limiting action is as shown in Figure 4-1.

Note that this curve is *not* the inverse of the ideal pre-emphasis curve. Such a curve would only be generated if the input level to the high-frequency limiter corresponded to 100% modulation. However, the dual-band limiter constrains the steady-state level of sine waves to well below the level corresponding to 100% modulation. So this test shows the high-frequency limiter's limiting only the upper part of the pre-emphasis curves.

The thresholds and dynamic characteristics of the dual-band limiter and high-frequency limiters have been carefully crafted so that these circuits work harmoniously with the Smart Clipper and FCS Overshoot corrector to control peak levels without audible distortion, pumping, or other undesirable side-effects. While the steady-state characteristics of the CAM-1 may seem unusual to those familiar with older-technology peak limiter designs, we submit that the "proof is in the listening."

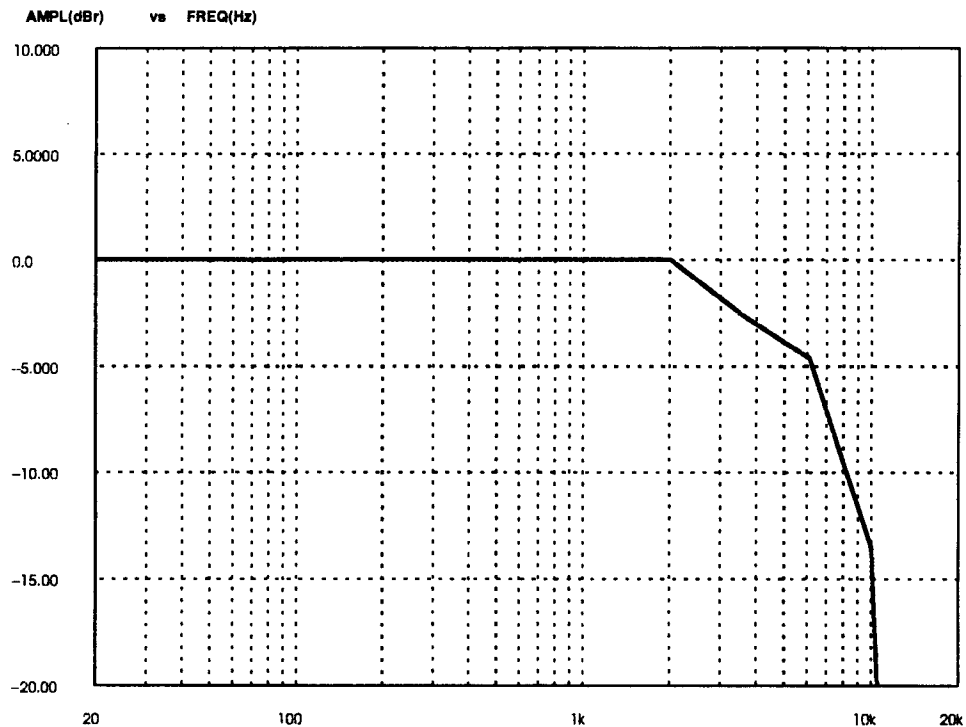

Figure 4-1: CAM-1 Limiting Curve

**12. Measure harmonic distortion.**

- A  Disconnect the spectrum analyzer from the CAM-1.
- B  Connect the audio oscillator to the CAM-1's input.
- C  Force the CAM-1 into TEST mode by momentarily connecting the anode of CR38 to the -15 volt power supply, using a jumper lead.
  - Verify that the TEST lamp lights.
- D  Set the oscillator for 1kHz.
- E  Set the oscillator's input level control to make the voltmeter read +8dBu.
  - The voltmeter should still be monitoring the CAM-1's output.
  - +8dBu is 2dB below 100% modulation, presuming that the adjustment made to the output level control in step 7-D on page 4-8 has not been changed.
- F  Measure the total harmonic distortion at 20Hz, 50Hz, 100Hz, 400Hz, 1kHz, 2.5kHz, 5kHz, and 8kHz.
  - The THD should not exceed 0.075% at any frequency.
  - Of course, you may use more frequencies and/or an automatically sweeping distortion analyzer if you wish to make a more thorough measurement.
- G  Force the CAM-1 into OPERATE mode by momentarily connecting the anode of CR32 to the -15 volt power supply, using a jumper lead.
- H  Adjust the oscillator output level to make the LIMITING meter indicate +5dB of limiting.
- I  Measure the total harmonic distortion at 20Hz, 50Hz, 100Hz, 400Hz, 1kHz, 2.5kHz, 5kHz, and 8kHz.
  - The THD should not exceed 0.075% at any frequency above 150Hz. As with any limiter, distortion will rise slightly at very low frequencies. Typically, harmonic distortion is 0.2% at 50Hz, 0.1% at 100Hz, and 0.05% at 200Hz and higher.

**13. Measure noise.**

- A  Remove the oscillator from the CAM-1.
- B  Connect a wire between the (+) and (-) terminals of the CAM-1's input to short it.
- C  Switch a 20-20kHz band-pass filter into the metering circuit of the audio voltmeter.
- D  Measure the level at the CAM-1's output with the voltmeter.
  - The noise should not exceed -75dBu in a 20-20kHz bandwidth, using true R.M.S. detection in the meter. (Note that +10dBu = 100% modulation, so the dynamic range exceeds 85dB if the above specification is met.)

**14. Test the balanced floating line amplifier.**

- A  Connect the oscillator to the CAM-1's input.
- B  Set the CAM-1's OUTPUT LEVEL control fully clockwise.
- C  Force the CAM-1 into TEST mode by momentarily connecting the anode of CR38 to the -15 volt power supply, using a jumper lead.
- D  Set the oscillator frequency to 1kHz.
- E  Observe the output between pins 2 and 3 of the CAM-1 output XLR-type connectors with the audio voltmeter. Observe the MONITOR OUTPUT of the voltmeter with the oscilloscope.

The audio voltmeter must have a balanced input.

- F  Advance the oscillator's OUTPUT ATTENUATOR until clipping occurs at the CAM-1's output.

Verify that the output level exceeds +21dBu.

- G  Reduce the CAM-1's output level to +18dBu.

- H  Momentarily short pin 2 of the CAM-1 output XLR-type connector to ground.

Verify that the output level is between +17.5dBu and +18.5dBu.

- I  Momentarily short pin 3 of the CAM-1 output XLR-type connector to ground.

Verify that the output level is between +17.5dBu and +18.5dBu.

- J  Remove the load and the connections to the output.

- K  Connect the (-) input of the audio voltmeter to pin 1 of the CAM-1's output XLR-type connector.

- L  With the audio voltmeter, observe pin 2, then pin 3 of the CAM-1's output XLR-type connector.

Verify that the levels observed are within 3dB of each other.

**15. Test D.C. offset.**

- A  Mute the oscillator.

- B  Observe the CAM-1 (+) OUTPUT terminal with the DVM.

Verify that the DC offset is less than 15mV (typically less than 5mV).

- C  Observe the CAM-1 (-) OUTPUT terminal with the DVM.

Verify that the DC offset is less than 15mV (typically less than 5mV).

**16. Reset Jumper JD back to its default PRE-EMPH setting.**

# Section 5

# Troubleshooting

<u>page</u>	<u>contents</u>
5-2	<b>Problems and Possible Causes</b>
5-2	RFI, Hum, Clicks, Or Buzzes
5-2	Power Supply Problems
5-2	Balanced Output Amplifier Failure
5-2	Poor Peak Control
5-3	Audible Distortion
5-4	<b>Troubleshooting IC Opamps</b>
5-4	<b>Technical Support</b>
5-5	<b>Factory Service</b>
5-5	<b>Shipping Instructions</b>



### **Caution**

The installation and servicing instructions in this manual are for use by qualified personnel only. To avoid electric shock do not perform any servicing other than that contained in the Operating Instructions unless you are qualified to do so. Refer all servicing to qualified service personnel.

## Problems and Possible Causes

Always verify that the problem is not in the source material being fed to the CAM-1, or in other parts of the system.

### RFI, Hum, Clicks, Or Buzzes

A grounding problem is likely. Review the information on grounding on page 2-4.

The CAM-1's RF suppression should be adequate for the vast majority of installations. However, installation next to a high-power transmitter might still cause problems. Additional RF suppression, careful examination of the grounding scheme, and other techniques familiar to the broadcast engineer may be needed.

### Power Supply Problems

The voltage regulators are operated conservatively and we expect them to be very reliable. Before replacing the regulators, check to see whether other abnormalities in the circuitry (such as a shorted IC) have caused excessive current demand which is, in turn, causing the regulator ICs to either current limit or go into thermal shutdown (the two built-in protective modes). If it becomes necessary to replace a regulator, be sure to re-mount it exactly as before (use the other regulator as a model). For maximum resistance to thermally-induced mechanical fatigue, solder the regulator leads to the circuit board after the regulators have been firmly mounted to their heat sinks.

To prevent high-frequency oscillations, regulators IC48 and IC49 are frequency compensated at their outputs by C101-102. If C101-102 is ever replaced, be sure to use a low-inductance aluminum electrolytic. A tantalum can fail because the current-delivering capacity of the power supply can cause a runaway condition if the dielectric is punctured momentarily; a high-inductance aluminum can fail to prevent a regulator from oscillating. Check for oscillation on the power bus with an oscilloscope if C101-102 is replaced.

### Balanced Output Amplifier Failure

The 5532 and 411 opamps used in the balanced output amplifier may be freely replaced as necessary. However, the circuit is extremely sensitive to the characteristics of the resistors, so field repair of resistor failure (which is very unlikely) requires replacement of the entire output amplifier resistor header assembly if adequate headroom and common-mode rejection are to be maintained (see page 5-5 for information about factory service).

### Poor Peak Control

Apparent peak control problems may actually result from problems with the transmission link that the CAM-1 is driving. A subcarrier generator, telephone line, or digital link, for

example, could introduce overshoot and ringing. A device with poor frequency response might cause “tilt” with low-frequency material.

Be sure that the instrument used to measure the peak output of the CAM-1 (or the device it is driving) has accurate transient response and dynamic accuracy. Inaccurate measuring instruments (such as many popular modulation monitors) can introduce tilt into the waveform prior to metering, causing the meter to falsely indicate peak overshoots.

*Real* failure of the CAM-1 to control peaks (as verified by an oscilloscope monitoring the CAM-1 output) can be caused by failures in the FCS Overshoot Corrector circuit.

### **Audible Distortion**

First make sure that the program material presented to the CAM-1’s inputs is clean and distortion-free.

If the limiting meter’s red segment is lighting, reduce the amount of limiting by reducing the drive level to the CAM-1’s input.

If you can still hear distortion, check the adjustment of CLIPPER BIAS trimmer R167. If it has been set more than 50% clockwise, this can introduce slight audible distortion on some program material. (See the assembly drawing in **Section 6** for locations of components).

Many potential circuit failures in the CAM-1 could cause distortion. Most would be detected by performing the **Performance Evaluation and Alignment** procedure starting on page 4-4.



## Troubleshooting IC Opamps

IC opamps are operated such that the characteristics of their associated circuits are essentially independent of IC characteristics and dependent only on external feedback components. The feedback forces the voltage at the (–) input terminal to be extremely close to the voltage at the (+) input terminal. Therefore, if you measure more than a few millivolts difference between these two terminals, the IC is probably bad.

Exceptions are opamps used without feedback (as comparators) and opamps with outputs that have been saturated due to excessive input voltage because of a defect in an earlier stage. However, if an opamp's (+) input is more positive than its (–) input, yet the output of the IC is sitting at –14 volts, the IC is almost certainly bad. The same holds true if the above polarities are reversed. Because the characteristics of the CAM-1's circuitry are essentially independent of IC opamp characteristics, an opamp can usually be replaced without recalibration. Realignment must be performed if IC25 is replaced.

A defective opamp may appear to work, yet have extreme temperature sensitivity. If parameters appear to drift excessively, freeze-spray may aid in diagnosing the problem. Freeze-spray is also invaluable in tracking down intermittent problems. But *use it sparingly*, because it can cause resistive short circuits due to moisture condensation on cold surfaces.

## Technical Support

If you require technical support, contact Orban customer service. Be prepared to accurately describe the problem. Know the serial number of your CAM-1 — this is printed on the rear panel of the unit.

Telephone:	(1) 510/351-3500	or Write:	Customer Service
			Orban
or Fax:	(1) 510/351-1001		1525 Alvarado Street
			San Leandro, CA 94577 USA

## Factory Service

Before you return a product to the factory for service, we recommend that you refer to this manual. Make sure you have correctly followed installation steps and operation procedures. If you are still unable to solve a problem, contact our Customer Service for consultation. Often, a problem is relatively simple and can be quickly fixed after telephone consultation.

If you must return a product for factory service, please notify our Customer Service by telephone, *before* you ship the product; this helps us to be prepared to service your unit upon arrival. Also, when you return a product to the factory for service, we recommend you include a letter describing the problem.

Please refer to the terms of your Limited One-Year Standard Warranty, which extends to the first end-user. After expiration of the warranty, a reasonable charge will be made for parts, labor, and packing if you choose to use the factory service facility. Returned units will be returned C.O.D. if the unit is not under warranty. Orban will pay return shipping if the unit is still under warranty. In all cases, transportation charges to the factory (which are usually quite nominal) are paid by the customer.

## Shipping Instructions

Use the original packing material if it is available. If it is not, use a sturdy, double-walled carton no smaller than 22 x 13.5 x 2.5 inches (56 x 35 x 7 cm), with a minimum bursting test rating of 200 pounds (91 kg). Place the chassis in a plastic bag (or wrap it in plastic) to protect the finish, then pack it in the carton with at least 1.5 inches (4 cm) of cushioning on all sides of the unit. "Bubble" packing sheets, thick fiber blankets, and the like are acceptable cushioning materials; foam "popcorn" and crumpled newspaper are not. Wrap cushioning materials tightly around the unit and tape them in place to prevent the unit from shifting out of its packing. Close the carton without sealing it and shake it vigorously. If you can hear or feel the unit move, use more packing. Seal the carton with 3-inch (8 cm) reinforced fiberglass or polyester sealing tape, top and bottom in an "H" pattern. Narrower or parcel-post type tapes will not withstand the stresses applied to commercial shipments.

Mark the package with the name of the shipper, and with these words in red:

**DELICATE INSTRUMENT, FRAGILE!**

Insure the package properly. Ship prepaid, not collect. Do not ship parcel post.

# Section 6

# Technical Data

<u>page</u>	<u>contents</u>
6-2	<b>Specifications</b>
6-4	<b>Circuit Description</b>
6-14	Figure 6-1: 9kHz Low-Pass Filter Response in Passband
6-14	Figure 6-2: 9kHz Low-Pass Filter Response
6-15	Figure 6-3: 1.2kHz Low-Pass Filter Response
6-18	Figure 6-4: Response of FCS Sidechain Low-Pass Filter
6-21	<b>Parts List</b>
6-22	Obtaining spare parts
6-30	<b>Schematics, Assembly Drawings</b>
6-39	<b>Abbreviations</b>

## Specifications

### Performance

**Frequency Response:** Below the threshold of limiting and pre-emphasis is flat;  $\pm 0.25\text{dB}$ , 20-9,000Hz. at 100% modulation, peak energy response follows the inverse of the pre-emphasis curve.

**Bandwidth Limiting:** Flat to 9kHz,  $-10\text{dB}$  at 10.4kHz,  $-75\text{dB}$  at 11.3kHz.

**RMS Noise:**  $>80\text{dB}$  below 100% modulation (measured after de-emphasis).

**Total Harmonic Distortion:** At 5dB of gain reduction,  $<0.2\%$  at 50Hz,  $<0.1\%$  at 100Hz,  $<0.05\%$  at 200 and higher.

### Audio Processing Circuitry

**Range of Gain Reduction:** 25dB.

**Attack and Release Time:** Program-dependent.

**Pre-Emphasis:** High frequency boost to help overcome the roll-off in AM radios.

**Peak Control:** Provides absolute protection against over-modulation under all input conditions.

### Installation

#### *Audio Input*

**Impedance:**  $10\text{k}\Omega$ , active balanced, EMI-suppressed.

**Operating Level:** Usable with  $-30\text{dBu}$  to  $+10\text{dBu}$  reference (line-up) level lines. ( $0\text{dBu} = 0.775\text{Vrms}$ ; for this application, the dBm @ $600\Omega$  scale on voltmeters can be read as if were calibrated in dBu.)

**Maximum Input Level:**  $+27\text{dBu}$ .

**Connector:** XLR-type female connector.

#### *Audio Output*

**Impedance:**  $30\Omega$ , electronically balanced and floating. Will drive loads of  $600\Omega$  or greater. Level at 100% modulation adjustable up to  $+24\text{dBu}$ .

**Operating Level:** Front-panel controls permit use with  $-10\text{dBm}$  to  $+8\text{dBm}$  systems. Output clipping level is  $>+20\text{dBm}$  @ $600\Omega$ .

**Connector:** XLR-type male connector.

*Physical*

**Meter:** 10-segment LED bargraph display shows limiting, 25 to 2.5dB.

**Indicators:** Two LEDs light to show operation of gating and high-frequency limiting.

**Dimensions (HxWxD):** 1  $\frac{3}{4}$ " (4.5 cm) high, 19" (48.3 cm) wide, 9  $\frac{5}{8}$ " (24.5 cm) deep.

**Weight:** 5.5 kg.

**Power Requirements:** 1200-260VA, 50-60Hz. IEC mains connector. EMI-suppressed.

**Fuse:**  $\frac{1}{4}$ -amp 3AG-type Slow-Blow.

**Operating Temperature Range:** 32-113°F (0-45°C)

**Humidity:** 0-90% RH (non-condensing)

**Warranty**

**One year, parts and labor:** Subject to the limitations set forth in Orban's Standard Warranty Agreement.

**Specifications subject to change without notice.**

## Circuit Description

On the following pages, a detailed description of each circuit's function is accompanied by a component-by-component description of that circuit. **Keywords are highlighted** throughout the circuit descriptions to help you quickly locate the information you need.

The circuitry is described in thirteen major blocks: input buffer, phase rotator, dual-band limiter, dual-band limiter control circuit, gating detector, LIMITING metering, high-frequency limiter, "Smart Clipper," VCA (voltage-controlled amplifier), Frequency- Contoured Sidechain Overshoot Corrector, balanced floating output amplifier, control logic, and power supply.

The **block diagram** on page 6-31 illustrates the following overview of CAM-1 circuitry.

The signal, which enters the CAM-1 in a balanced form, receives moderate **RF suppression**, then is applied to a very low-noise differential amplifier made up of three opamps in the classic "instrumentation amplifier" configuration. This circuit functions as an "**active transformer**."

The signal then is applied to a single-pole phase rotator to make speech waveforms more symmetrical.

The **dual-band limiter** divides the audio into two bands (above and below 150Hz) with a phase-linear crossover whose outputs sum to the crossover's original input signal. The "master" band (above 150Hz) usually controls the gain of both the "master" and "bass" bands, which track to preserve frequency balances. However when strong bass appears, the "bass" band compressor increases its limiting to prevent the bass from overdriving the following peak limiting circuitry.

Each of the two band-compressors is a feedback circuit: the output of the compressor is looped back to develop a **gain-control signal** that is applied to its VCA. This arrangement results in superior stability of characteristics with time and temperature, extremely low distortion, and optimized control-loop dynamic response.

The proprietary dual-band limiter **timing module** generates a control signal that enables the CAM-1 to achieve natural-sounding control and very low modulation distortion. All dynamic parameters are determined by the timing module on the basis of the past history of the input. They were very carefully "tuned" to minimize audible compression-induced artifacts.

The voltage-controlled gain blocks used in the CAM-1's **dual-band limiter** are class-A **voltage-controlled amplifiers** (VCAs). They have a "decilinear" response: their gain is proportional to the exponential of the voltage applied to their gain-control port. Any "**thumps**" due to control current feedthrough are eliminated by applying DC offset to the VCA's input.

A **gating detector** monitors the level of the CAM-1's input signal and activates the gate if this level drops below a factory-set threshold.

The **LIMITING meter** consists of ten comparators arranged to produce a meter with a 0 to 25dB linear scale.

**High-frequency limiting** is effected by applying the output of the dual-band limiter to a bandpass filter. When summed with its input, the output of this filter provides a 6dB/octave **pre-emphasis** up to approximately 5kHz. The +3dB breakpoint frequency for the pre-emphasis is determined by the amount of bandpass output that is summed with the input signal — the greater the contribution from the bandpass output, the lower the breakpoint frequency.

The contribution from the bandpass output a fixed voltage divider, and by circuitry that can dynamically reduce the pre-emphasis to effect the high-frequency limiting function.

The output of the high-frequency limiter is applied to the “**Smart Clipper**,” which controls peak levels while canceling difference-frequency intermodulation distortion. It operates in two frequency bands (above and below 1.2kHz). The signal is clipped and then applied to the top band, which eliminates distortion below 1.2kHz. The un-clipped signal is applied to an 1.2kHz low-pass filter and then to a VCA. The difference between the clipper’s input and its output is rectified, low-pass filtered, and used to control the gain of the VCA. This smoothed control signal limits low-frequency peaks effectively while introducing less distortion than would a control signal that were not smoothed.

The distortion cancellation in the “**Smart Clipper**” adds some overshoots to its output. Its integral **9kHz low-pass filter**, which is used as a delay line as well as a means for spectrum control, also adds overshoots. These are reduced in the **FCS Overshoot Corrector**. This circuit operates as a “band-limited clipper” — it clips off peaks exceeding 100% modulation but does not introduce out-of-band power above 9kHz as would a simple clipper. If the subsequent **de-emphasis** has been jumpered out, the absolute peak ceiling at the CAM-1’s output will be independent of frequency; if de-emphasis is applied, the peak ceiling will be frequency-dependent, following the de-emphasis curve selected by jumper JB.

The output of the de-emphasis circuit is applied to the **OUTPUT LEVEL control**, and then to the **balanced output amplifier**. This amplifier uses two opamps in a complex cross-coupled arrangement with positive and negative feedback to simulate an **active transformer**. A **servo amplifier** ensures that the quiescent DC level at the output of the amplifier will be centered at ground.

**Unregulated voltage** is supplied by two pairs of full wave diode rectifiers. **Regulated voltages** are supplied by a pair of overrated 500mA “three-terminal” IC regulators. Several pairs of opamps provide bias and reference voltages for various parts of the circuitry.

## 1. Input Buffer

Located On Main Circuit Board

The audio is applied to an RFI suppression network and to an attenuation pad (which can be strapped for 0 or 20dB attenuation). The RFI-suppressed audio is then applied to a low-noise true instrumentation amplifier with symmetrical, high-impedance (+) and (-) inputs. The gain of this amplifier can be adjusted from 0.88 to approximately 47 (a 34.5dB range). If this range does not yield the desired amount of limiting, the Input Attenuation pads should be re-strapped.

Because the input is DC-coupled, only small amounts of differential DC should be applied to the input. Since the input would typically be fed by the output of a transformer or capacitively-coupled amplifier, this should not be a problem.

### Component-Level Description:

The input is RF-filtered, then applied to 10K bridging pad R100, R103. Strapping R101 and R102 into the pad introduces 20dB attenuation (The CAM-1 is shipped with R101 and R102 strapped in for 20dB attenuation).

The output of the pad is connected to low-noise true instrumentation amplifier IC2-A, IC1-A, IC1-B, and associated resistors. R104, R105 provide bias current for IC1-A, IC2-A, which are low-noise bipolar-input dual IC opamps. R106-A, R106-B are feedback resistors for IC1-A, IC2-A. The differential gain is controlled by the series resistance of R107 and the INPUT ATTENUATOR control R1. The common-mode gain of the IC1 pair is 1.

The differential output of IC1-A and IC2-A is converted to a single-ended output; the common mode component of the output is nulled by differential amplifier IC1, IC2-A and associated resistors.

Nearby lightning strikes may induce energy into the CAM-1's audio input that is sufficient to pass through the RFI protective networks and destroy IC1 and IC2. If the CAM-1 is installed in a lightning-prone location, keep spare NE5532 chips in stock. Installation of varistors between each side of the audio input lead and earth may help prevent such problems.

Ceramic RFI-suppression capacitors shunt RF from the input leads to the chassis. Since these capacitors are not effective at VHF and higher frequencies, ferrite beads have been placed around the input and output leads to suppress such high-frequency RF. Although this RF suppression is modest, it should be adequate for the vast majority of installations.



## 2. Phase Rotator

---

Located On Main Circuit Board

The output of the input buffer amplifier is applied to a circuit that has a flat magnitude response, but which applies to 0 to 180 degree phase shift to the input signal, depending on frequency. It has been found by experiment that this processing reduces the natural asymmetry in voice waveforms, making them fit better into the peak modulation constraints of the broadcast channel.

### Component-Level Description:

The phase rotation is generated by IC2-B and associated components. This is a classic single-pole all-pass filter whose operation is best explained by a mathematical analysis.

## 3. Dual-Band Limiter

---

Located On Main Circuit Board

The dual-band limiter<sup>1</sup> divides the audio band into two bands (above and below 150Hz) with a phase-linear crossover whose outputs sum to the crossover's original input signal. The major part of the dual-band limiter is the "master" channel (above 150Hz). This is a feedback limiter. Its gain-control voltage is summed in a dB-linear manner with the control voltage developed by the "bass" limiter to control the gain of the "bass" VCA, which passes frequencies below 150Hz.

When the bass content of the program is moderate, the control voltage summation forces the "bass" limiter to limit as much as the "master" limiter, and the system operates essentially as a wideband limiter, preserving frequency balances. However, when the bass content of the program is heavy, sufficient bass appears at the output of the "bass" limiter to activate the "bass" control loop, causing the "bass" channel to limit more than the "master" channel. This prevents overdriving later peak-limiting stages in the CAM-1, while also preventing the bass from causing unnatural-sounding gain reduction in the frequencies above 150Hz. Such unnatural-sounding gain reduction would occur if the limiter were *truly* wideband, because the bass would then force excess limiting in the *entire* audio frequency range instead of being momentarily rolled-off by the "bass" limiter.

Because the attack time of the "bass" control loop is relatively slow, transients can still pass through the "bass" limiter without limiting. To prevent these transients from inter-modulating with the material in the "master" band, the output of the "bass" band is limited with a clipper.

The dual-band limiter's crossover is a 12dB/octave phase-linear crossover whose outputs sum to the original input of the crossover without phase or amplitude error. The crossover is "distributed": part of it is placed prior to the VCAs in the dual-band limiter, and part of it is placed after the VCAs and bass clipper. The crossover thus rolls off any harmonic distortion introduced by the bass clipper.

<sup>1</sup> U.S. Patent #4,249,042

### Component-Level Description:

IC3-A and associated components form a 150Hz 6dB/octave high-pass filter, which is the first part of the “master” crossover. The “master” crossover is completed with shelving filter R118, R119, R120, C4.

This shelving filter feeds IC4-C, an integrated VCA with a virtual-ground input and current-mode output. Its voltage gain is proportional to the exponential of the voltage appearing at pin 5, and to the negative exponential of the voltage appearing at pin 7. Thus the VCA’s gain in dB is proportional to the control voltage appearing at pin 7 subtracted from the control voltage appearing at pin 5. The current-mode output of IC4-C is converted to a voltage in IC5-A. This is the output of the “master” limiter.

The output of high-pass filter IC3-A is subtracted from its input with R116 and R117. This produces a complementary low-pass filter, whose output is applied to bass VCA IC4-D. The current-mode output of IC4-D is converted to a voltage in IC5-B. This output of the “bass” limiter is applied to clipper CR19, CR20. R136, R137, C15 are a low-pass filter that complete the “distributed crossover.”

The outputs of the “master” and “bass” bands are summed in IC3-B and applied to the high-frequency limiter.

R121, C16 are frequency compensation components to prevent VCA IC4-C from oscillating. R172, C17 perform the same function for IC4-D.

## 4. Dual-band Limiter Control

Located On Main Circuit Board

Both limiters in the **dual-band limiter** are feedback circuits: the gain-controlled output of a given limiter is used to develop a **gain-control signal** that is applied to the gain-control port of its VCA. This arrangement results in superior stability of characteristics with time and temperature, extremely low distortion, and optimized control-loop dynamic response.

The output of a given VCA is applied to two comparators. One detects signals that exceed a positive reference set by the **clipping voltage reference**, and the other detects signals that exceed the negative reference.

The comparators feed the dual-band limiter **timing module**, which contains proprietary circuitry that outputs a control voltage with dynamics that achieve natural-sounding control and low modulation distortion.

### Component-level description:

The output of IC5-A in the “master” VCA is applied to two comparators in IC7. The outputs of these comparators are “OR’ed” together, and go negative whenever the output of IC5-A exceeds the positive or negative CLIP voltage. These negative-going signals are applied to the **timing module**, which develops a gain control voltage that depends on the past history of the program material. This voltage represents the gain of the VCA in dB.

The output of "bass" VCA at IC5-B is processed similarly.

The CLIP voltages are generated by IC6 (and associated components). The CLIPPING trim control R167 sets the clip voltages and thus the threshold of limiting. In turn, this determines the drive level to the following high-frequency limiter and peak-limiting circuitry and thus the amount of limiting and clipping that these circuits will execute.

The timing module has "master" and "bass" outputs. The "master" output is buffered by IC16-B; the "bass" output is buffered by IC16-A.

These buffers contain diodes CR11 and CR12 within their feedback loops. These diodes force the outputs of the buffers to be low-impedance *unidirectional* voltage sources, negative-going with increasing gain reduction, with a scale factor of approximately 0.93V/dB. 0V corresponds to 0dB gain reduction. Approximately -14V corresponds to the maximum available gain reduction (25dB).

These buffer amplifiers can be OR'ed together for stereo tracking, such that the output is the *lowest* voltage produced by any buffer. Thus all channels produce the same amount of limiting as the channel requiring the most limiting.

The "master" control voltage drives the "master" VCA IC4-C through voltage divider R148, R149. The "master" control voltage is also summed with the "bass" control voltage in R146 and R147. This sum drives the gain control port of the "bass" VCA IC4-D.

## 5. Gating Detector

Located On Main Circuit Board

A **gating detector** monitors the level of the CAM-1's input signal, and activates the gate if this level drops below a factory-set threshold. When on, the gate slows the release time by a factor of about 50x. For most program material with relatively short pauses or low-level passages, the limiter's gain appears to "freeze." However, the gain is still recovering very slowly toward maximum so the limiter cannot get "stuck" at abnormally low gain if a low-level passage lasts for many minutes.

### Component-Level Description:

The gating detector uses a level detector built into IC4-B. The input signal to the dual-band limiter is applied to high-pass filter R138, C20. The -3dB frequency of this filter is approximately 340Hz.

The output of this filter is applied to the input of IC4-B's internal rectifier. This input (pin 15 of IC4) is an "AC virtual ground" — its DC quiescent voltage is approximately +1.8VDC, but it has a very low AC input impedance and little or no AC signal can be detected at this pin when the rectifier is working correctly.

The peak output of the rectifier appears at pin 13 of IC4 in dB-linear form. It is smoothed by C22. The release time of the detector is determined by R139.

IC7 is used as a comparator to determine when the gate should turn on or off. R140 and R141 bias the (-) input of the comparator to determine its threshold. This threshold can be lowered by applying -15V to CR10 such that the gate is OFF for all input signals.

Under OPERATE conditions and in absence of signal, pins 9 and 11 of IC7 are pulled negative and the gate is ON (i.e., the gain of the dual-band limiter is frozen). If the level at the input to the dual-band limiter exceeds about -23dBu, the output of the comparator goes positive. This turns the gate OFF and permits the normal limiter release process to occur. The release is switched on and off by circuitry inside the timing module, and is triggered by the signal on pin 14 of IC7-C. This is positive when the gate is OFF and negative otherwise. IC8D is used as an inverter to apply positive feedback to the gate circuit. This provides hysteresis to prevent the gain from "chattering."

## 6. Limiting Meter

Located On Display Circuit Board

The "master" band **LIMITING** meter consists of ten comparators with current regulators at their outputs. The comparators are arranged to produce a meter with a dB-linear scale. The ten LEDs in the bargraph are connected in series.

### Component-Level Description:

The "master" control voltage, which is dB-linear and negative-going, is inverted and attenuated by IC2-A (on the display board) such that +3V = 25dB gain reduction. The attenuated voltage is mixed with a 50 or 60Hz "dither" signal through C2, R6 (connected to the power transformer secondary), and then applied to the input of LM3914 **bargraph driver** IC1.

The LM3914 bargraph consists of ten comparators with current regulators at their outputs. The comparators are arranged to produce a meter with a linear scale. The LM3914 applies current to the appropriate node to light the desired LEDs.

Q6 is used as a zener diode to reduce the supply voltage to the LM3914 so that it is within the chip's 25V maximum rating. R7 sets the current through the LED bargraph.

The LM3914 has an internal string of series resistors that provide reference voltages for its ten comparators. The bottom of this string is grounded at pin 4; the top of the string is provided with +3.00VDC from pin IC23A of on the main board.

C1 bypasses the LM3914 power supply to prevent the LM3914 from oscillating.

## 7. High-Frequency Limiter

Located On Main Circuit Board

The output of the dual-band limiter is applied to a **bandpass filter** with a peak frequency of 36.4kHz, a “Q” of 0.77, and a peak gain of 0dB. When summed with its input, the output of this filter provides a 6dB/octave shelving **pre-emphasis** with breakpoints at 1.31kHz and 4.13kHz. The breakpoint frequencies for the pre-emphasis are determined by the amount of bandpass output that is summed with the input signal and by the low-pass filter formed by R208, R209, C210, C87.

The contribution from the bandpass output is determined by a gain-setting voltage divider and by circuitry that can dynamically reduce the pre-emphasis to effect the high-frequency limiting function.

Note that **swept sine wave tests** of the high-frequency limiter will not yield the exact inverse of the pre-emphasis curves. This is because a high-pass filter causes the comparators to see a signal which is slightly different from the signal at the high-frequency limiter output, and because the **threshold of high-frequency limiting** is set above the steady-state output level of the dual-band limiter. The threshold is set this way to keep the high-frequency limiter from being activated by peak overshoots resulting from the moderate attack time of the dual-band limiter when operating on program material.

The output of the high-frequency limiter is applied to a **peak-limiting system** consisting of the “**Smart Clipper**” and **FCS Overshoot Corrector**, both of which are described below. These circuits provide absolute peak control at the CAM-1’s output.

### Component-Level Description:

The bandpass filter consists of IC39-A and associated circuitry. Bandpass response can be measured at pin 1 of IC39-A.

The contribution from the bandpass output is determined by the gain of voltage divider R208, R209, R210, C87. The contribution of the bandpass filter to the output is further determined by the resistance of JFET Q101, which can dynamically reduce the pre-emphasis to effect the high-frequency limiting function.

IC38, which has a gain of 28.5dB, compensates for the loss in the voltage divider. The output of IC38 (representing the band-passed signal) is summed with the input signal in IC39-B to create the pre-emphasized signal.

The break frequencies for the pre-emphasis are 1307Hz and 4134Hz. The positive and negative peak levels of the pre-emphasized signal are evaluated by two comparators in IC41. If either exceeds the 6.08V threshold voltages established by R229-R231 (and inverter IC40-B), the appropriate comparator fires. Each comparator has an open collector NPN output stage and charges the high-frequency limiter smoothing circuit negative through attack time resistor R225. The smoothing circuit consists of CR40-CR43, C81, C91, and R224.

C86, R228 form the 6dB/octave high-pass filter that prevents the high-frequency limiter from being activated on low-frequency program material.

In the absence of high-frequency gain reduction, the output of the smoothing circuit (at the anode of CR42) is biased at a positive voltage determined by FET BIAS trimmer R223. This pinches-off Q101.

When high-frequency gain reduction occurs, the voltage at the anode of CR42 goes more negative than the quiescent voltage, turning on Q101 and resulting in less and less pre-emphasis. Pre-emphasis is dynamically decreased until comparator IC41 no longer fires, indicating that the high-frequency overload has been removed.

IC32-B drives the HF LIMIT LED. The FET control voltage is applied to IC32-B's pin 6; the quiescent FET bias is applied to pin 5. In addition, IC32-B's pin 5 is offset by current flowing through R221, which forces IC32-B's pin 5 to be more negative than its pin 6, and causes pin 7 of IC32-B to go low (close to ground). When the voltage on pin 6 becomes more negative than pin 5 due to high-frequency gain reduction, pin 7 goes high, lighting HF LIMITER LED CR8. CR8 is OFF when IC32-B's pin 7 is close to ground.

## **8. "Smart Clipper"**

Located On Main Circuit Board

The "Smart Clipper"<sup>2</sup> is a peak-limiting circuit that operates in two frequency bands. Its input signal is clipped, and the output of the clipper is applied to a 1.2-9kHz band-pass filter created by subtracting the output of a 1.2kHz low-pass filter from the output of a 9kHz low-pass filter that is phase- and amplitude-matched to the 1.2kHz low-pass filter. This band-pass filter removes both difference-frequency intermodulation distortion caused by the clipper and program material below 1.2kHz.

<sup>2</sup> U.S. Patent #4,208,548, U.K. Patent #2,001,495

Program material below 1.2kHz is handled by a second circuit path. The input signal to the clipper is applied to a second 1.2kHz low-pass filter identical to the first 1.2kHz low-pass filter. The output of the second 1.2kHz low-pass filter is applied to a VCA, and the output of the VCA is added to the output of the 1.2-9kHz band-pass filter. (The VCA circuit is described on page 6-16.)

The gain of the VCA is controlled by a circuit that subtracts the output of the clipper from its input, rectifies this difference signal, adds a DC level to it, and then smooths this signal with a low-pass filter whose delay is equal to that of the 1.2kHz low-pass filters. The gain of the VCA is inversely proportional to this signal: clipped peaks will cause gain reduction in the VCA.

If the control-signal low-pass filter were not present, this would be equivalent to clipping the program material below 1.2kHz identically to the program material above 1.2kHz. Being of opposite polarity, the output signals from the two 1.2kHz low-pass filters would cancel completely, and the output of the entire "Smart Clipper" circuit would simply be equivalent to a clipper followed by a 9kHz low-pass filter.

However, the control-signal low-pass filter smooths the control signal to the VCA that processes the program material below 1.2kHz, and the output signals from the two 1.2kHz low-pass filters no longer cancel completely. The addition of the control-signal low-pass filter thus reduces distortion. Because the audio signal applied to the 1.2kHz VCA has been low-pass filtered, it is relatively "slow," and smoothing the control voltage to the VCA therefore does not cause consequential overshoot. The overshoot that is added can be considered to be a "distortion-canceling signal" that adds a slight amount of peak uncertainty to the output of the "Smart Clipper" in order to significantly reduce distortion by comparison to a simple clipper.

### Component-Level Description:

The signal enters and is clipped by CR45, CR46. It is then applied to a chain of three allpass phase correctors: IC29, IC30, IC31 and associated components. Each of these circuits has a flat amplitude response but a phase response that changes with frequency. Together, these three circuits add delay as necessary to make the total group delay of the phase correctors plus the following 9kHz low-pass filter as constant as possible.

The 9kHz low-pass filter is an active-RC analog of a passive LC ladder filter. It is realized by resistors, capacitors, and frequency-dependent negative resistors (FDNRs). An FDNR is realized with a dual opamp, three resistors, and two capacitors. When the passive LC filter is transformed into an active RC filter, inductors become resistors, resistors become capacitors, and capacitors become FDNRs.

Each FDNR resonates with a series resistor to create a notch in the frequency response of the filter. This is analogous to a series LC circuit to ground. The notches are located in the "stopband" (beyond approximately 11.26kHz). The circuit associated with IC13 produces a notch at 21.16kHz  $\pm 4\%$ . The circuit associated with IC14 produces a notch at 11.42kHz  $\pm 4\%$ . The circuit associated with IC15 produces a notch at 13.14kHz  $\pm 4\%$ .

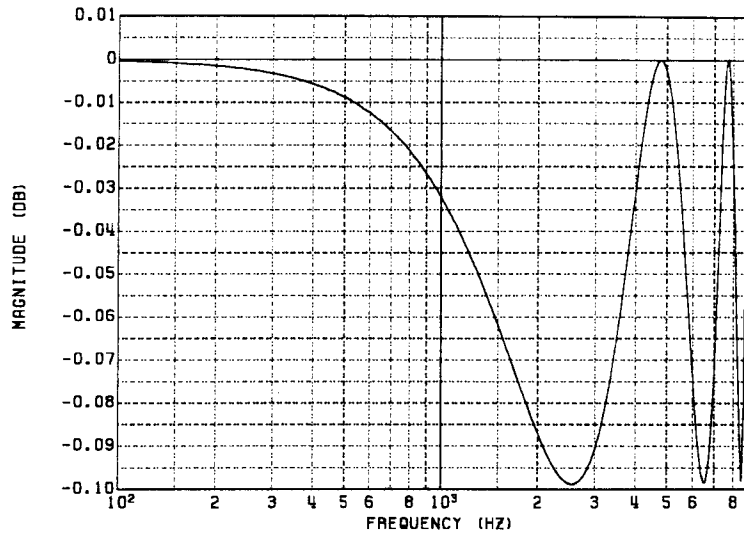

Figure 6-1: 15kHz Low-Pass Filter Response in Passband

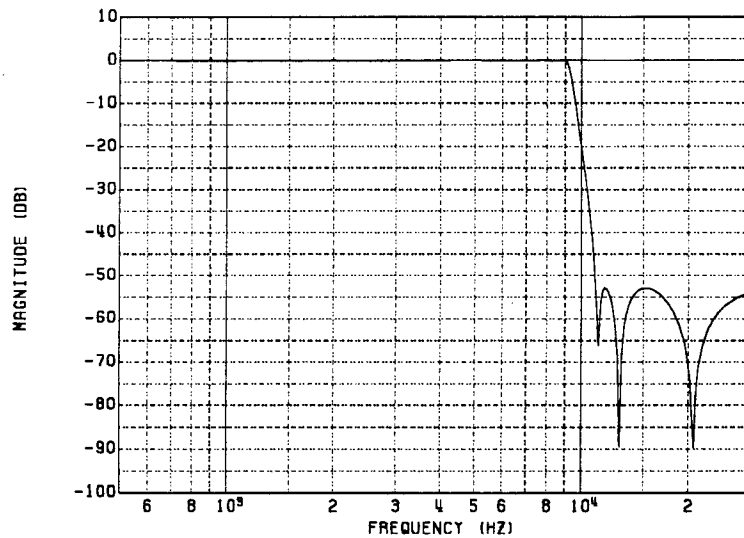

Figure 6-2: 15kHz Low-Pass Filter Response Passband and Stopband

To avoid possible clipping, the signal is attenuated 2dB with voltage divider R252, R253 before being applied to the filter. This gain is made up by IC11-A to restore unity gain at low frequencies. IC11-A is also a summing amplifier for the two sidechains each containing a 1.2kHz low-pass filter. IC12-A is a servo amplifier that eliminates any DC offset at IC11-A's output.



The output of clipper CR45, CR46 is also applied to a 1.2kHz low-pass filter consisting of IC9 and associated components. This filter is phase- and amplitude-matched to the 9kHz low-pass filter from 0 to 1.2kHz. Its output is subtracted from the output of the 9kHz low-pass filter in IC11-A to yield a 1.2-9kHz band-pass function. Fig. 6-3 shows its normal frequency response.

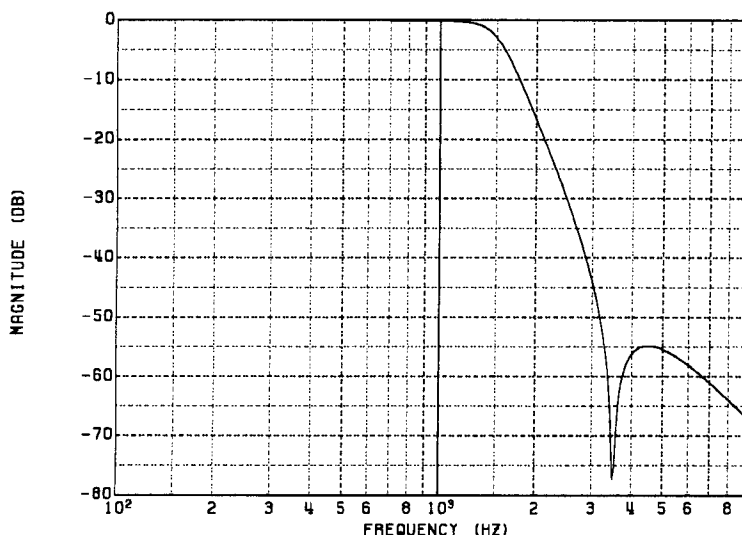

Figure 6-3: 2kHz Low-Pass Filter Response  
Passband and Stopband

If the frequency response of any filter is abnormal, first replace any opamps associated with the filter. If this does not cure the problem, suspect passive component failure. Capacitors are more likely to fail than resistors. Components interact, so it is almost impossible to identify which passive component has failed by examining the overall response of the filter. Instead, it is usually necessary to test the passive components on an impedance bridge, one at a time.

IC28 and associated components subtract the output of clipper CR45, CR46 from its input and full-wave rectify the difference signal, which appears at pin 3 of IC27-A. This signal appears as a series of positive-going "spikes" representing the signal that was removed by the clipper. IC27-A amplifies this signal by 19.3dB and applies it to control-voltage low-pass filter IC27-B and associated components. This low-pass filter has a relatively gentle roll-off. Its time delay is equal to the delay of the IC9 1.2kHz filter.

The output of low-pass filter IC27-B is applied to pin 6 of IC25-B. This pin is the divider control port of the "Smart Clipper" VCA (IC25 and associated components — see the detailed description below). The gain of the VCA is inversely proportional to the current flowing into this pin. This pin normally sits at about -13.5VDC, while the output of low-pass filter IC27-B is centered about 0VDC. Therefore a constant bias current flows into pin 6 of IC25-B through R304. This bias current determines the quiescent gain of the VCA when CR45 and CR46 are not clipping.

The audio to the VCA is supplied by 1.2kHz low-pass filter IC26 and associated components. This filter, which is identical to the IC9 filter, is fed by the unclipped signal occurring prior to CR45 and CR46. When no clipping occurs, the signals through the IC9 and IC26 filters are identical but out-of-polarity and therefore cancel upon summation in IC11-A. The remaining signal at the output of IC11-A is therefore the output of the 9kHz low-pass filter.

When CR45 and CR46 clip, pin 7 of IC27-B goes positive, causing the control current into the VCA to increase and its gain to decrease proportionally, causing a distortion-reduced "clipping" function to be applied to the output signal from the IC26 1.2kHz low-pass filter. When clipping occurs, the signals through the two 1.2kHz low-pass filters are thus no longer identical, no longer cancel, and peak control occurs as described earlier in the overview to this section.

## 9. Voltage-Controlled Amplifier in "Smart Clipper"

Located On Main Circuit Board

The current-controlled gain block used in the "Smart Clipper" is a proprietary class-A **voltage-controlled amplifier (VCA)**. It operates as a two-quadrant analog divider with gain *inversely* proportional to a current injected into a first gain-control port, and is cascaded with a two-quadrant analog multiplier with gain *directly* proportional to a current injected into a second gain-control port. For most gains, levels, and frequencies, total harmonic distortion (THD) is well under 0.1%. Overload-to-noise ratio (noise measured in a 20-20,000Hz band) is typically 90dB, and is constant with respect to gain and level.

A specially-graded CA3280 Dual Operational Transconductance Amplifier ("OTA") contains two matched, non-linear gain-control blocks with differential inputs and current outputs. Used alone, one such gain-control block would introduce considerable distortion. Therefore, the first of the two matched blocks is used as the feedback element for a separate opamp, and the second is driven by the pre-distorted output of that opamp. The gain of the VCA is therefore *inversely* proportional to the gain of the non-linear gain-control blocks. This enables the VCA to function as a two-quadrant analog *divider*.

If the VCA is not perfectly balanced, "thumps" due to **control current** feedthrough can appear at the output. These are eliminated by applying DC offset to the VCA's input.

The basic current-controlled gain in the dual-band limiter is inversely proportional to the control current generated by the "Smart Clipper" control circuitry.

### Component-Level Description:

The first gain-control port is pin 6 of IC25-B; the second gain-control port is pin 3 of IC25-A.

IC25 is the specially-graded Orban IC containing two matched non-linear gain-control blocks with differential inputs and current outputs. The forward-path opamp in the VCA is IC24.

The output of IC24 is first attenuated by R305, R306, C76, and then applied to the input of the feedback element IC25-B at pin 9. The output of IC24 is

pre-distorted as necessary to force the current *output* of IC25-B to precisely and linearly cancel the audio input into the “virtual ground” summing junction of IC24. This same pre-distorted voltage is also connected to the input of IC25-A at pin 15. Thus the output of IC25-A at pin 13 is an undistorted current. This current is converted to a voltage in IC11-A, which is also the summing amplifier for the “Smart Clipper” filters.

The VCA behaves like a two-quadrant analog *divider* when the control current from IC27-B is applied to the control port (pin 6) of IC25-B. The gain-control current injected into this control port is developed by the “Smart Clipper” control circuitry.

The gain of IC25-A is fixed by the current through R310.

Second-harmonic distortion is introduced by differential offsets in either section of IC25. This distortion is canceled by applying a nulling voltage directly to the input of IC25-A by means of resistor network R307, R308, and L DIST NULL trimmer R309.

The control-voltage feedthrough, which can occur if the VCA is not perfectly balanced, are equivalent to multiplying the control current by DC. An adjustable DC offset is applied to the VCA input provided by R300 and L FEEDTHROUGH trimmer R301 for nulling this equivalent DC multiplication to zero.

R87 and R92 further balance cancellation to prevent audio modulation of the control current for IC25-B.

C64, C74, R302, R303 provide frequency-compensation to prevent the VCA from oscillating supersonically.

## **10. Frequency-Contoured Sidechain Overshoot Corrector**

Located On Main Circuit Board

This circuit<sup>3</sup> acts as a “band-limited safety clipper.” It subtracts the output of a clipper from its input. If this differential signal were then subtracted from the clipper’s input, it would be equivalent to clipping the signal and would eliminate overshoot. However, this would add out-of-band power that would destroy the CAM-1’s excellent spectral control. Therefore, the differential signal is low-pass filtered prior to subtraction. The low-pass filter has a rising response towards 9kHz, and its frequency response falls quickly thereafter. The filter’s rising gain for frequencies immediately below 9kHz helps compensate for the removal of the clipper-induced frequencies above 9kHz that would otherwise be required to fully control the peaks.

<sup>3</sup> U.S. Patent #4,460,871

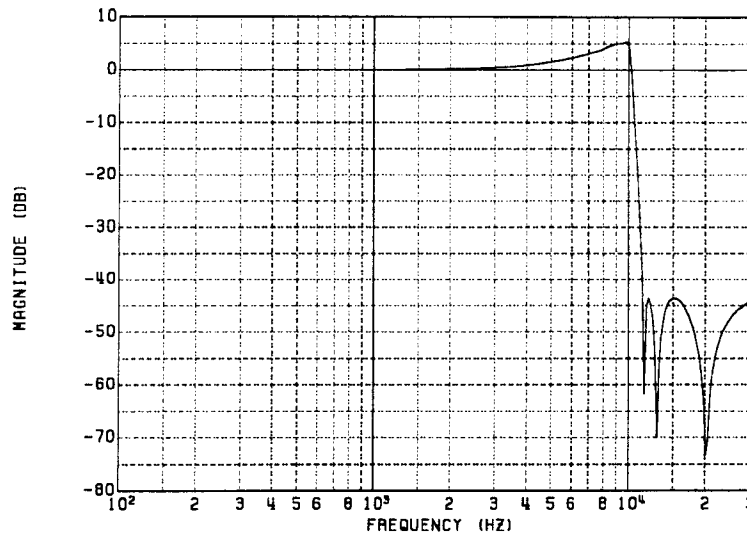

Figure 6-4: Response of FCS Sidechain Low-Pass Filter in the Passband and Stopband

#### Component-Level Description:

The output of the “Smart Clipper” (containing some overshoots) is applied to clipper CR30, CR31. IC11-B subtracts the output of this clipper from its input. This differential signal is applied to the 9.96kHz sidechain filter consisting of IC20, IC21, IC22 and associated components. This is an FDNR-based low-pass filter like the 9kHz filter in the “Smart Clipper” (see page 6-12). Fig. 6-4 shows its frequency response. The circuit associated with IC20 produces a notch at 11.53kHz  $\pm$ 4%. The circuit associated with IC21 produces a notch at 13.0kHz  $\pm$ 4%. The circuit associated with IC22 produces a notch at 20.22kHz  $\pm$ 4%.

IC17-A buffers the filter and makes up gain lost in voltage divider R99, R409. IC17-A is also the summing amplifier for servo amplifier IC12-B and associated components. This servo minimizes DC offset at the CAM-1’s output.

The output of the “Smart Clipper” is also applied to IC10 and associated components. This is an allpass delay element. Its amplitude response is flat, but its group delay varies with frequency. Its group delay plus the group delay produced by allpass phase shifter IC17-B and associated components closely matches the group delay of the 9.96kHz FCS sidechain low-pass filter, whose output is subtracted from the delayed signal in IC17-B to cancel overshoots.

The group delay of the FCS sidechain filter (and thus, the group delay of its matching delay network) is not constant with frequency. Allpass phase shifters IC18 and IC19 apply group delay correction to the FCS sidechain filter to make the group delay of the entire FCS circuit constant with frequency to ensure that peak levels are correctly controlled.

The output of the FCS circuit is applied to a de-emphasis circuit consisting of C82 and R444. De-emphasis can be defeated by lifting C416's ground with jumper JD. IC33-A buffers the de-emphasis circuit and drives the OUTPUT LEVEL control. This control is buffered by IC33-B, which drives the balanced floating output amplifier circuit.

## **11. Balanced Floating Output Amplifier**

---

Located On Main Circuit Board

The **balanced output amplifier** converts the unbalanced single-ended signal to a balanced, floating output. Output impedance is  $30\Omega$ ,  $\pm 5\%$ .

Simpler "electronically-balanced to ground" output stages can cause problems because grounding one side of their output to unbalance them will short an output amplifier to ground. In contrast, the CAM-1 output stage is balanced and *floating*, so it simulates a **true transformer output**. Because the output is floating, either side can be grounded to obtain an unbalanced output. When either side is grounded, the overall output level changes very little (less than 0.5dB), and no ill effects occur. The output of the CAM-1 can be freely connected to a **patch bay** without concern that problems may occur if one side of the output is grounded.

### Component-Level Description:

IC35 is a low-offset servo amplifier that centers the average DC level at the (+) and (-) outputs of the module around ground. The floating characteristic is achieved by complex cross-coupled positive and negative feedback between the two sections of IC34, and its operation is not readily explainable except by a detailed mathematical analysis. Opamps may be replaced; resistors are specially matched and should not be replaced (see page 5-2).

## **12. Control Logic**

---

Located On Main Circuit Board and Display Board

The **control logic** determines the operating state of the analog circuitry. Two R/S latches remember the TEST and TONE states. (These are unavailable from the front panel, and are used only for service and alignment by service technicians.) If the logic is in none of these states, it is, by definition, in the OPERATE state.

### Component-Level Description:

CMOS NAND gates IC42-C and IC43-A are cross-coupled to form an R/S latch that remembers the TEST state. The logic operates from -15V to ground, and uses "negative logic": -15V is TRUE and 0V is FALSE. So in BYPASS mode, pin 4 of IC43-A is at -15V.

The TONE mode has an identically-structured R/S latch associated with it.

Momentarily connecting the OPERATE line to -15V forces the TEST and TONE lines FALSE through diodes CR33, CR35, and CR36. Power-up circuit CR32, C105, and R452 pulls the OPERATE line TRUE through C418 on power-up.

If the TONE line goes TRUE, it forces the TEST line TRUE through CR38.

Current is applied to a "tree" consisting of CR2-CR5. The current thus lights at least one of these LEDs, depending on the state of the logic driving them. If the TONE mode is selected, *both* the TONE and TEST LEDs are lit, and both are driven in series from the same current. If both the TONE and TEST LEDs are OFF, current is then diverted to CR4 and CR5 (whose normal voltage drop is higher than CR2 and CR3), and the OPERATE lamp lights.

### 13. Power Supply

Located On Main Circuit Board

**Unregulated voltage** is supplied by two pairs of full-wave diode rectifiers. The nominal unregulated voltage is  $\pm 22$  volts DC at rated line voltage. This will vary widely with line voltage variations. **Regulator dropout** will occur if the unregulated voltage falls below about  $\pm 17.8$  volts.

Regulated voltages are supplied by a pair of overrated 500mA "three-terminal" IC regulators. Because they are operated conservatively, they are expected to be reliable.

#### Component-Level Description:

The two pairs of full-wave diode rectifiers that supply **unregulated voltage** are located in package CR2. The rectifier pairs drive energy storage capacitors C103 and C104. The power transformer T1 can be strapped for either 115-volt or 230-volt operation (the two sections of the primary are paralleled for 115-volt operation and connected in series for 230-volt operation).

The pair of ICs which supply regulated voltages are "three-terminal" IC regulators IC48, IC49. IC48 and IC49 are frequency-compensated by C101-102 at their outputs to prevent high-frequency oscillations. Small 0.1F/25V ceramic capacitors bypass the power busses to ground locally throughout the board to prevent signal-carrying ICs from oscillating due to excessive power-lead inductance.

(If replaced, C101-102 *must* be replaced by low-inductance aluminum electrolytic capacitors only — see "Power Supply Problems" on page 5-2.)

## Parts List

Parts are listed by ASSEMBLY, then by TYPE, then by REFERENCE DESIGNATOR. Widely used common parts are not listed; such parts are described generally below (examine the part to determine exact value). See the following assembly drawings for locations of components.

**SIGNAL DIODES**, if not listed by reference designator in the following parts list, are:

Orban part number 22101-000, Fairchild (FSC) part number 1N4148, also available from many other vendors. This is a silicon, small-signal diode with ultra-fast recovery and high conductance. It may be replaced with 1N914 (BAY-61 in Europe).

(BV: 75V min. @  $I_T = 5\mu\text{A}$ ;  $I_T$ : 25nA max. @  $V_T = 20\text{V}$ ;  $V_F$ : 1.0V max. @  $I_F = 100\text{mA}$ ; trr: 4ns max.) See Miscellaneous list for ZENER DIODES (reference designator VRxx).

**RESISTORS** should only be replaced with the same style and with the *exact* value marked on the resistor body. If the value marking is not legible, consult the schematic or the factory. Performance and stability will be compromised if you do not use exact replacements. Unless listed by reference designator in the following parts list, you can verify resistors by their physical appearance:

**Metal film resistors** have conformally-coated bodies, and are identified by five color bands or a printed value. They are rated at  $\frac{1}{8}$  watt @  $70^\circ\text{C}$ ,  $\pm 1\%$ , with a temperature coefficient of 100 PPM/ $^\circ\text{C}$ . Orban part numbers 20038-xxx through 20045-xxx, USA Military Specification MIL-R-10509 Style RN55D. Manufactured by R-Ohm (CRB-1/4FX), TRW/IRC, Beyschlag, Dale, Corning, and Matsushita.

**Carbon film resistors** have conformally-coated bodies, and are identified by four color bands. They are rated at  $\frac{1}{4}$  watt @  $70^\circ\text{C}$ ,  $\pm 5\%$ . Orban part numbers 20001-xxx, Manufactured by R-Ohm (R-25), Piher, Beyschlag, Dale, Phillips, Spectrol, and Matsushita.

**Carbon composition resistors** have molded phenolic bodies, and are identified by four color bands. The 0.090 x 0.250 inch (2.3 x 6.4 mm) size is rated at  $\frac{1}{4}$  watt, and the 0.140 x 0.375 inch (3.6 x 9.5 mm) size is rated at  $\frac{1}{2}$  watt, both  $\pm 5\%$  @  $70^\circ\text{C}$ . Orban part numbers 2001x-xxx, USA Military Specification MIL-R-11 Style RC-07 ( $\frac{1}{4}$  watt) or RC-20 ( $\frac{1}{2}$  watt). Manufactured by Allen-Bradley, TRW/IRC, and Matsushita.

**Cermet trimmer resistors** have  $\frac{3}{8}$ -inch (9 mm) square bodies, and are identified by printing on their sides. They are rated at  $\frac{1}{2}$  watt @  $70^\circ\text{C}$ ,  $\pm 10\%$ , with a temperature coefficient of 100 PPM/ $^\circ\text{C}$ . Orban part numbers 20510-xxx and 20511-xxx. Manufactured by Beckman (72P, 68W- series), Spectrol, and Matsushita.

### **Obtaining spare parts**

Special or subtle characteristics of certain components are exploited to produce an elegant design at a reasonable cost. *It is therefore unwise to make substitutions for listed parts.* Consult the factory if the listing of a part includes the note "selected" or "realignment required."

Orban normally maintains an inventory of tested, exact replacement parts that can be supplied quickly at nominal cost. Standardized spare parts kits are also available. When ordering parts from the factory, please have available the following information about the parts you want:

- Orban part number
- Reference designator (e.g., C3, R78, IC14)
- Brief description of part
- Model, serial, and "M" (if any) number of unit — see rear-panel label

To facilitate future maintenance, parts for this unit have been chosen from the catalogs of well-known manufacturers whenever possible. Most of these manufacturers have extensive worldwide distribution and may be contacted through their local offices. Addresses for each manufacturer's USA headquarters are given on page 6-29.



REF DES	DESCRIPTION	ORBAN P/N	VEN (1)	VENDOR P/N	ALTERNATE VENDORS (1)	NOTES
------------	-------------	-----------	------------	------------	--------------------------	-------

**CHASSIS ASSEMBLY**

Miscellaneous

Transformer, Power; 41.7VCT, 17.7VA	55007-000	ORB				
Fuse, Type T, 1/4A	28025-125	LFE	218.250			
Filter, Line, 3 Amp	28015-000	COR	3EF1		MANY	

**DISPLAY BOARD ASSEMBLY**

Capacitors

C1	Alum., Radial, 63V, -20% +100%; 2.2uF	21209-522	SPR	502D 225G063BB1C	PAN	
C2	Met. Polyester, 50V, 5%; 0.01uF	21445-310	PAN	ECQ-V1H103JZ		
C3	Monolythic Ceramic, 50V, 20%; 0.1uF	21123-410	SPR	1C25 Z5U104M050B	KEM	
C4	Monolythic Ceramic, 50V, 20%; 0.1uF	21123-410	SPR	1C25 Z5U104M050B	KEM	
C5	Monolythic Ceramic, 50V, 20%; 0.1uF	21123-410	SPR	1C25 Z5U104M050B	KEM	
C6	Monolythic Ceramic, 50V, 20%; 0.1uF	21123-410	SPR	1C25 Z5U104M050B	KEM	

Diodes

CR2	LED, Red	25106-003	HP	HLMP-1300	GI	
CR3	LED, Red	25106-003	HP	HLMP-1300	GI	
CR4	LED, Green	25106-002	HP	HLMP-1503	GI	
CR5	LED, Green	25106-002	HP	HLMP-1503	GI	
CR6	LED Array, 9-Yellow, 1-Red	25152-000	ORB			
CR7	LED, Red	25106-003	HP	HLMP-1300	GI	
CR8	LED, Red	25106-003	HP	HLMP-1300	GI	

Integrated Circuits

IC1	Digital, Display Driver	24712-302	NAT	LM3914		
IC2	Linear, Dual Opamp	24202-202	RAY	RC4558NB		MOT,FSC

Resistors

R1	Pot, Single; 25K	20761-000	ORB			
----	------------------	-----------	-----	--	--	--

Transistors

Q2	Transistor, Signal, PNP	23002-101	MOT	2N4402		FSC
Q3	Transistor, Signal, PNP	23002-101	MOT	2N4402		FSC
Q6	Transistor, Signal, NPN	23202-101	MOT	2N4400		FSC

**FOOTNOTES:**

- |  |  |
|--|--|
| <p>(1) See page 6-29 for Vendor abbreviations.<br/>                 (2) No Alternate Vendors known at publication.<br/>                 (3) Actual part is specially selected from part listed, consult Factory.</p> | <p>(4) Realignment may be required if replaced; See Circuit Description and/or Alignment Instructions.</p> |
|--|--|

**SPECIFICATIONS AND SOURCES FOR REPLACEMENT PARTS**

Orban Model CAM-1  
 Chassis Assembly - Miscellaneous.  
 Display Board Assembly - Capacitors, Diodes,  
 Integrated Circuits, Resistors, Transistors.

REF DES	DESCRIPTION	ORBAN P/N	VEN (1)	VENDOR P/N	ALTERNATE VENDORS (1)	NOTES
------------	-------------	-----------	------------	------------	--------------------------	-------

**MAIN BOARD ASSEMBLY**

Capacitors

C1	Mica, 500V, +1/2pF -1/2pF; 10pF	21017-010	CD	CD15-CD100D03	SAN
C2	Met. Polyester, 50V, 5%; .047uF	21445-347	PAN	ECQ-V1H473JZ	
C3	Met. Polyester, 50V, 5%; .047uF	21445-347	PAN	ECQ-V1H473JZ	
C4	Met. Polycarb., 100V, 2%; 0.12uF	21602-412	ECI	652A 1B124G	IMB
C5	Mica, 500V, +1/2pF -1/2pF; 47pF	21017-047	CD	CD15-CD470D03	SAN
C6	Monolythic Ceramic, 50V, 20%; 0.1uF	21123-410	SPR	1C25 Z5U104M050B	KEM
C7	Alum., Radial, 63V, -20% +100%; 1uF	21209-510	SPR	502D 105G063BBIC	PAN
C8	Monolythic Ceramic, 50V, 20%; 0.1uF	21123-410	SPR	1C25 Z5U104M050B	KEM
C9	Mica, 500V, +1/2pF -1/2pF; 10pF	21017-010	CD	CD15-CD100D03	SAN
C10	Monolythic Ceramic, 50V, 20%; 0.1uF	21123-410	SPR	1C25 Z5U104M050B	KEM
C11	Monolythic Ceramic, 50V, 20%; 0.1uF	21123-410	SPR	1C25 Z5U104M050B	KEM
C12	Polypropylene, 50V, 1%; 0.022uF	21701-322	NOB	CQ15P1H223FPP	
C13	Mica, 500V, +1/2pF -1/2pF; 10pF	21017-010	CD	CD15-CD100D03	SAN
C14	Met. Polyester, 50V, 5%; .047uF	21445-347	PAN	ECQ-V1H473JZ	
C15	Polypropylene, 50V, 2.5%; 0.068uF	21702-368	NOB	CQ15P1H683GPP	
C16	Met. Polyester, 50V, 5%; .0022uF	21445-222	PAN	ECQ-B1H222 F1	
C17	Met. Polyester, 50V, 5%; .0022uF	21445-222	PAN	ECQ-B1H222 F1	
C18	Mica, 500V, +1/2pF -1/2pF; 47pF	21017-047	CD	CD15-CD470D03	SAN
C19	Met. Polyester, 50V, 5%; .047uF	21445-347	PAN	ECQ-V1H473JZ	
C20	Met. Polyester, 50V, 5%; .047uF	21445-347	PAN	ECQ-V1H473JZ	
C21	Mica, 500V, 1%; 1000pF	21022-210	CD	CD19-FD102F03	SAN
C22	Alum., Radial, 63V, -20% +100%; 4.7uF	21209-547	SPR	502D 475G063BB1C	PAN
C23	Polypropylene, 50V, 1%; 4700pF	21701-247	NOB	CQ15P1H472FPP	WES
C24	Mica, 500V, +1/2pF -1/2pF; 5pF	21017-005	CD	CD15-CD050D03	SAN
C25	Mica, 500V, 1%; 220pF	21018-122	CD	CD15-FD221F03	SAN
C26	Mica, 500V, 1%; 1000pF	21022-210	CD	CD19-FD102F03	SAN
C27	Polypropylene, 50V, 1%; 4700pF	21701-247	NOB	CQ15P1H472FPP	WES
C28	Polypropylene, 50V, 1%; 4700pF	21701-247	NOB	CQ15P1H472FPP	WES
C29	Met. Polyester, 50V, 5%; 0.1uF	21445-410	PAN	ECQ-V1H104JZ	
C30	Polypropylene, 50V, 1%; 4700pF	21701-247	NOB	CQ15P1H472FPP	WES
C31	Polypropylene, 50V, 1%; 4700pF	21701-247	NOB	CQ15P1H472FPP	WES
C32	Polypropylene, 50V, 1%; 4700pF	21701-247	NOB	CQ15P1H472FPP	WES
C33	Monolythic Ceramic, 50V, 20%; 0.1uF	21123-410	SPR	1C25 Z5U104M050B	KEM
C34	Monolythic Ceramic, 50V, 20%; 0.1uF	21123-410	SPR	1C25 Z5U104M050B	KEM

**FOOTNOTES:**

- (1) See page 6-29 for Vendor abbreviations.
- (2) No Alternate Vendors known at publication.
- (3) Actual part is specially selected from part listed, consult Factory.

- (4) Realignment may be required if replaced; See Circuit Description and/or Alignment Instructions.

**SPECIFICATIONS AND SOURCES FOR REPLACEMENT PARTS**

Orban Model CAM-1  
Main Board Assembly - Capacitors.

REF DES	DESCRIPTION	ORBAN P/N	VEN (1)	VENDOR P/N	ALTERNATE VENDORS (1)	NOTES
<u>Capacitors (continued)</u>						
C70	Mica, 500V, 1%; 1000pF	21022-210	CD	CD19-FD102F03	SAN	
C71	Polypropylene, 50V, 1%; 4700pF	21701-247	NOB	CQ15P1H472FPP	WES	
C72	Polypropylene, 50V, 1%; 4700pF	21701-247	NOB	CQ15P1H472FPP	WES	
C73	Monolythic Ceramic, 50V, 20%; 0.1uF	21123-410	SPR	1C25 Z5U104M050B	KEM	
C74	Monolythic Ceramic, 50V, 20%; 0.1uF	21123-410	SPR	1C25 Z5U104M050B	KEM	
C75	Polypropylene, 50V, 1%; 4700pF	21701-247	NOB	CQ15P1H472FPP	WES	
C76	Mica, 500V, +1/2pF -1/2pF; 5pF	21017-005	CD	CD15-CD050D03	SAN	
C77	Mica, 500V, 5%; 150pF	21020-115	CD	CD15-FD151J03	SAN	
C78	Mica, 500V, 1%; 1000pF	21022-210	CD	CD19-FD102F03	SAN	
C79	Mica, 500V, 1%; 1000pF	21022-210	CD	CD19-FD102F03	SAN	
C80	Mica, 500V, 1%; 470pF	21022-147	CD	CD19-FD471F03	SAN	
C81	Tantalum, 35V, 10%; 0.22uF	21307-422	SPR	196D 224X9035HA1	MANY	
C82	Polypropylene, 50V, 1%; 0.01uF	21701-310	NOB	CQ15P1H103FPP	WES	
C83	Mica, 500V, 1%; 1000pF	21022-210	CD	CD19-FD102F03	SAN	
C84	Mica, 500V, 1%; 1000pF	21022-210	CD	CD19-FD102F03	SAN	
C85	Met. Polyester, 50V, 5%; .047uF	21445-347	PAN	ECQ-V1H473JZ		
C86	Mica, 500V, 5%; 1000pF	21024-210	CD	CD19-FD102J03	SAN	
C88	Monolythic Ceramic, 50V, 20%; 0.1uF	21123-410	SPR	1C25 Z5U104M050B	KEM	
C89	Monolythic Ceramic, 50V, 20%; 0.1uF	21123-410	SPR	1C25 Z5U104M050B	KEM	
C90	Met. Polyester, 50V, 5%; 0.1uF	21445-410	PAN	ECQ-V1H104JZ		
C91	Met. Polyester, 50V, 5%; 0.1uF	21445-410	PAN	ECQ-V1H104JZ		
C92	Monolythic Ceramic, 50V, 20%; 0.1uF	21123-410	SPR	1C25 Z5U104M050B	KEM	
C93	Monolythic Ceramic, 50V, 20%; 0.1uF	21123-410	SPR	1C25 Z5U104M050B	KEM	
C94	Monolythic Ceramic, 50V, 20%; 0.1uF	21123-410	SPR	1C25 Z5U104M050B	KEM	
C95	Monolythic Ceramic, 50V, 20%; 0.1uF	21123-410	SPR	1C25 Z5U104M050B	KEM	
C96	Mica, 500V, 5%; 1800pF	21024-218	CD	CD19-FD182J03	SAN	
C99	Monolythic Ceramic, 50V, 20%; 0.1uF	21123-410	SPR	1C25 Z5U104M050B	KEM	
C100	Monolythic Ceramic, 50V, 20%; 0.1uF	21123-410	SPR	1C25 Z5U104M050B	KEM	
C101	Alum., Radial, 25V, -20% +100%; 100uF	21206-710	PAN	ECE-A1EV101S		
C102	Alum., Radial, 25V, -20% +100%; 100uF	21206-710	PAN	ECE-A1EV101S		
C103	Alum., Axial, 40V, -10% +100%; 1000uF	21224-810	SIE	B41010-1000-40	PAN	
C104	Alum., Axial, 40V, -10% +100%; 1000uF	21224-810	SIE	B41010-1000-40	PAN	
C105	Ceramic Disc, 25V, 20%; 0.15uF	21106-415	CRL	UK25-154	MUR	
C106	Mica, 500V, +1/2pF -1/2pF; 10pF	21017-010	CD	CD15-CD100D03	SAN	

**FOOTNOTES:**

- (1) See page 6-29 for Vendor abbreviations.
- (2) No Alternate Vendors known at publication.
- (3) Actual part is specially selected from part listed, consult Factory.

- (4) Realignment may be required if replaced; See Circuit Description and/or Alignment Instructions.

**SPECIFICATIONS AND SOURCES FOR REPLACEMENT PARTS**

Orban Model CAM-1  
Main Board Assembly - Capacitors.

REF DES	DESCRIPTION	ORBAN P/N	VEN (1)	VENDOR P/N	ALTERNATE VENDORS (1)	NOTES
------------	-------------	-----------	------------	------------	--------------------------	-------

Diodes

CR2	Diode, Bridge, 200V, 1A	22301-000	VARO	VE-27	GI	
CR14	Diode, Signal, Hot Carrier	22102-001	HP	HP5082-2800	MANY	
CR30	Diode, Signal, Hot Carrier	22102-001	HP	HP5082-2800	MANY	
CR31	Diode, Signal, Hot Carrier	22102-001	HP	HP5082-2800	MANY	
CR45	Diode, Signal, Hot Carrier	22102-001	HP	HP5082-2800	MANY	
CR46	Diode, Signal, Hot Carrier	22102-001	HP	HP5082-2800	MANY	

Integrated Circuits

IC1	Linear, Dual Opamp	24207-202	SIG	NE5532N	TI,EXR	
IC2	Linear, Dual Opamp	24207-202	SIG	NE5532N	TI,EXR	
IC3	Linear, Dual Opamp	24207-202	SIG	NE5532N	TI,EXR	
IC4	Digital, Dynamic Range Processor	24719-302	PMI	SSM-2120		
IC5	Linear, Dual Opamp	24209-202	NAT	LF412CN		
IC6	Linear, Dual Opamp	24202-202	RAY	RC4558NB	MOT,FSC	
IC7	Quad Comparator	24710-302	NAT	LM339		
IC8	Quad Comparator	24710-302	NAT	LM339		
IC9	Linear, Dual Opamp	24207-202	SIG	NE5532N	TI,EXR	
IC10	Linear, Dual Opamp	24207-202	SIG	NE5532N	TI,EXR	
IC11	Linear, Dual Opamp	24207-202	SIG	NE5532N	TI,EXR	
IC12	Linear, Dual Opamp	24209-202	NAT	LF412CN		
IC13	Linear, Dual Opamp	24207-202	SIG	NE5532N	TI,EXR	
IC14	Linear, Dual Opamp	24207-202	SIG	NE5532N	TI,EXR	
IC15	Linear, Dual Opamp	24207-202	SIG	NE5532N	TI,EXR	
IC16	Linear, Dual Opamp	24206-202	TI	TL072CP	MOT	
IC17	Linear, Dual Opamp	24207-202	SIG	NE5532N	TI,EXR	
IC18	Linear, Dual Opamp	24207-202	SIG	NE5532N	TI,EXR	
IC19	Linear, Dual Opamp	24207-202	SIG	NE5532N	TI,EXR	
IC20	Linear, Dual Opamp	24207-202	SIG	NE5532N	TI,EXR	
IC21	Linear, Dual Opamp	24207-202	SIG	NE5532N	TI,EXR	
IC22	Linear, Dual Opamp	24207-202	SIG	NE5532N	TI,EXR	
IC23	Linear, Dual Opamp	24209-202	NAT	LF412CN		
IC24	Linear, Single Opamp	24014-202	SIG	NE5534N	TI	
IC25	Linear, Dual Opamp	24208-302	RCA	CA3280A		
IC26	Linear, Dual Opamp	24207-202	SIG	NE5532N	TI,EXR	
IC27	Linear, Dual Opamp	24209-202	NAT	LF412CN		

**FOOTNOTES:**

- |  |  |
|--|--|
| <p>(1) See page 6-29 for Vendor abbreviations.</p> <p>(2) No Alternate Vendors known at publication.</p> <p>(3) Actual part is specially selected from part listed, consult Factory.</p> | <p>(4) Realignment may be required if replaced; See Circuit Description and/or Alignment Instructions.</p> |
|--|--|

**SPECIFICATIONS AND SOURCES FOR REPLACEMENT PARTS**

Orban Model CAM-1  
Main Board Assembly - Diodes, Integrated Circuits.

REF DES	DESCRIPTION	ORBAN P/N	VEN (1)	VENDOR P/N	ALTERNATE VENDORS (1)	NOTES
------------	-------------	-----------	------------	------------	--------------------------	-------

Integrated Circuits (continued)

IC28	Linear, Dual Opamp	24207-202	SIG	NE5532N	TI,EXR	
IC29	Linear, Dual Opamp	24207-202	SIG	NE5532N	TI,EXR	
IC30	Linear, Dual Opamp	24207-202	SIG	NE5532N	TI,EXR	
IC31	Linear, Dual Opamp	24207-202	SIG	NE5532N	TI,EXR	
IC32	Linear, Dual Opamp	24203-202	MOT	MC1458CP1	TI,RCA	
IC33	Linear, Dual Opamp	24207-202	SIG	NE5532N	TI,EXR	
IC34	Linear, Dual Opamp	24207-202	SIG	NE5532N	TI,EXR	
IC35	Linear, Single Opamp	24017-202	NAT	LF411CN		
IC36	Linear, Dual Opamp	24202-202	RAY	RC4558NB	MOT,FSC	
IC37	Linear, Dual Opamp	24202-202	RAY	RC4558NB	MOT,FSC	
IC38	Linear, Single Opamp	24014-202	SIG	NE5534N	TI	
IC39	Linear, Dual Opamp	24207-202	SIG	NE5532N	TI,EXR	
IC40	Linear, Dual Opamp	24209-202	NAT	LF412CN		
IC41	Quad Comparator	24710-302	NAT	LM339		
IC42	Digital, NAND Gate	24501-302	RCA	CD4011BE	MOT	
IC43	Digital, NAND Gate	24501-302	RCA	CD4011BE	MOT	

Modules

A100	Module, Timing	31345-003-xx	ORB	Add suffix printed on part		
------	----------------	--------------	-----	----------------------------	--	--

Resistors

R106	Resistor Network, 8 POS; 10.0K	20202-503	AB	F16B-103-B	BEK	
------	--------------------------------	-----------	----	------------	-----	--

Transistors

Q100	Transistor, JFET/N	23406-101	NAT	J113	SIL	
Q101	Transistor, JFET/P	23407-101	NAT	J174	SIL	
Q102	Transistor, JFET/N	23406-101	NAT	J113	SIL	
Q103	Transistor, JFET/N	23406-101	NAT	J113	SIL	
Q104	Transistor, JFET/N	23406-101	NAT	J113	SIL	
Q105	Transistor, JFET/N	23406-101	NAT	J113	SIL	
Q200	Transistor, Signal, NPN	23202-101	MOT	2N4400	FSC	

FOOTNOTES:

- |  |  |
|--|--|
| <p>(1) See page 6-29 for Vendor abbreviations.<br/>                 (2) No Alternate Vendors known at publication.<br/>                 (3) Actual part is specially selected from part listed, consult Factory.</p> | <p>(4) Realignment may be required if replaced; See Circuit Description and/or Alignment Instructions.</p> |
|--|--|

SPECIFICATIONS AND SOURCES FOR REPLACEMENT PARTS

Orban Model CAM-1  
 Main Board Assembly - Integrated Circuits, Modules, Resistors, Transistors.

## Schematics, Assembly Drawings

The following drawings are included in this manual:

Page	Circuit Board	Drawing
6-31	Block Diagram	Assembly Drawing
6-32	Main	Assembly Drawing
6-33	AM Broadcast Audio Processor	Schematic
6-34	AM Broadcast Audio Processor	Schematic
6-35	AM Broadcast Audio Processor	Schematic
6-36	AM Broadcast Audio Processor	Schematic
6-37	Display	Assembly Drawing
6-38	Display	Schematic

These drawings reflect the actual construction of your unit as accurately as possible. Any differences between the drawings and your unit are almost undoubtedly due to product improvements or production changes since the publication of this manual. Major changes (when they occur) are described in addenda located at the front of this manual.

If you intend to replace parts, please read page 21

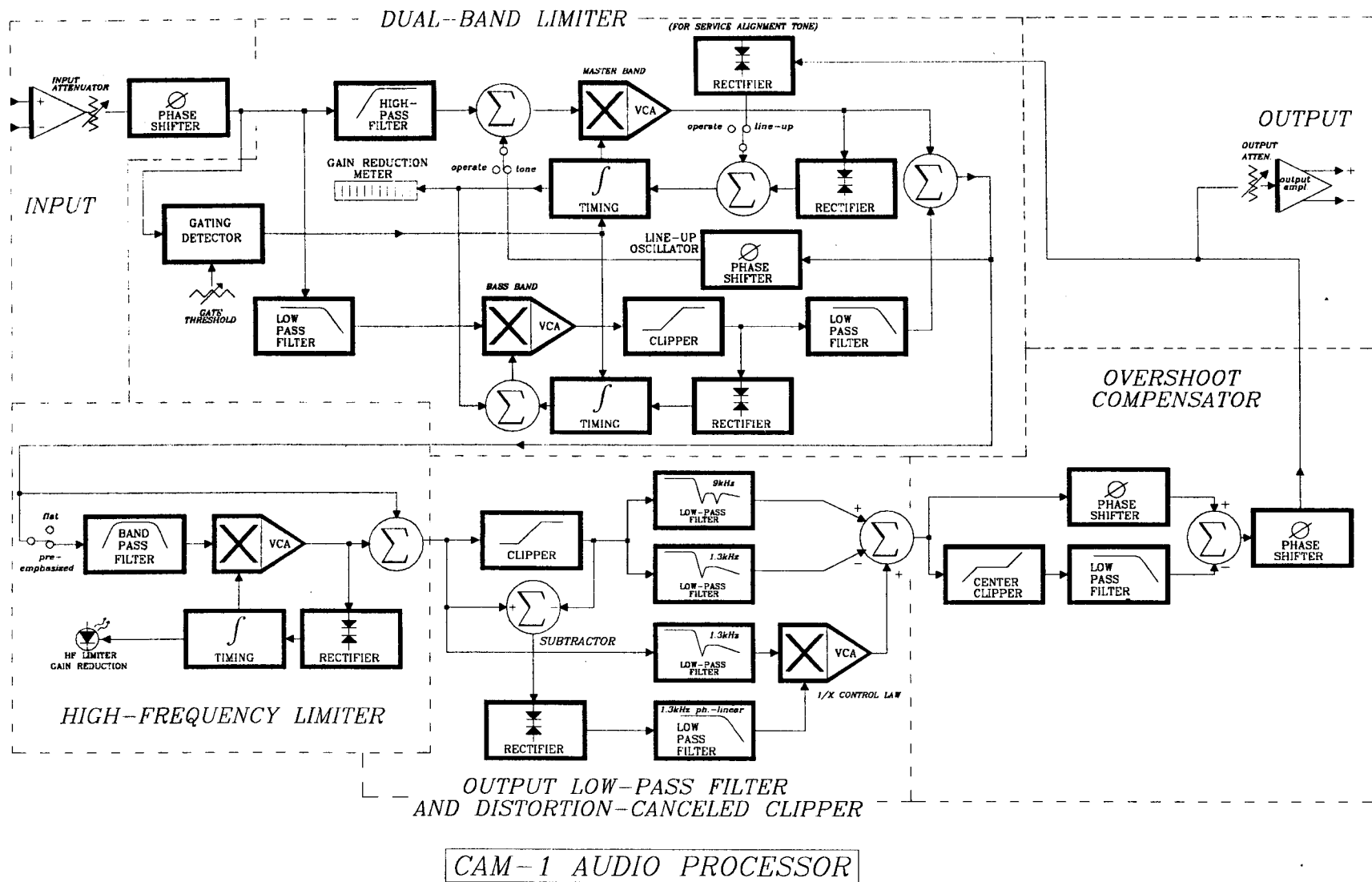

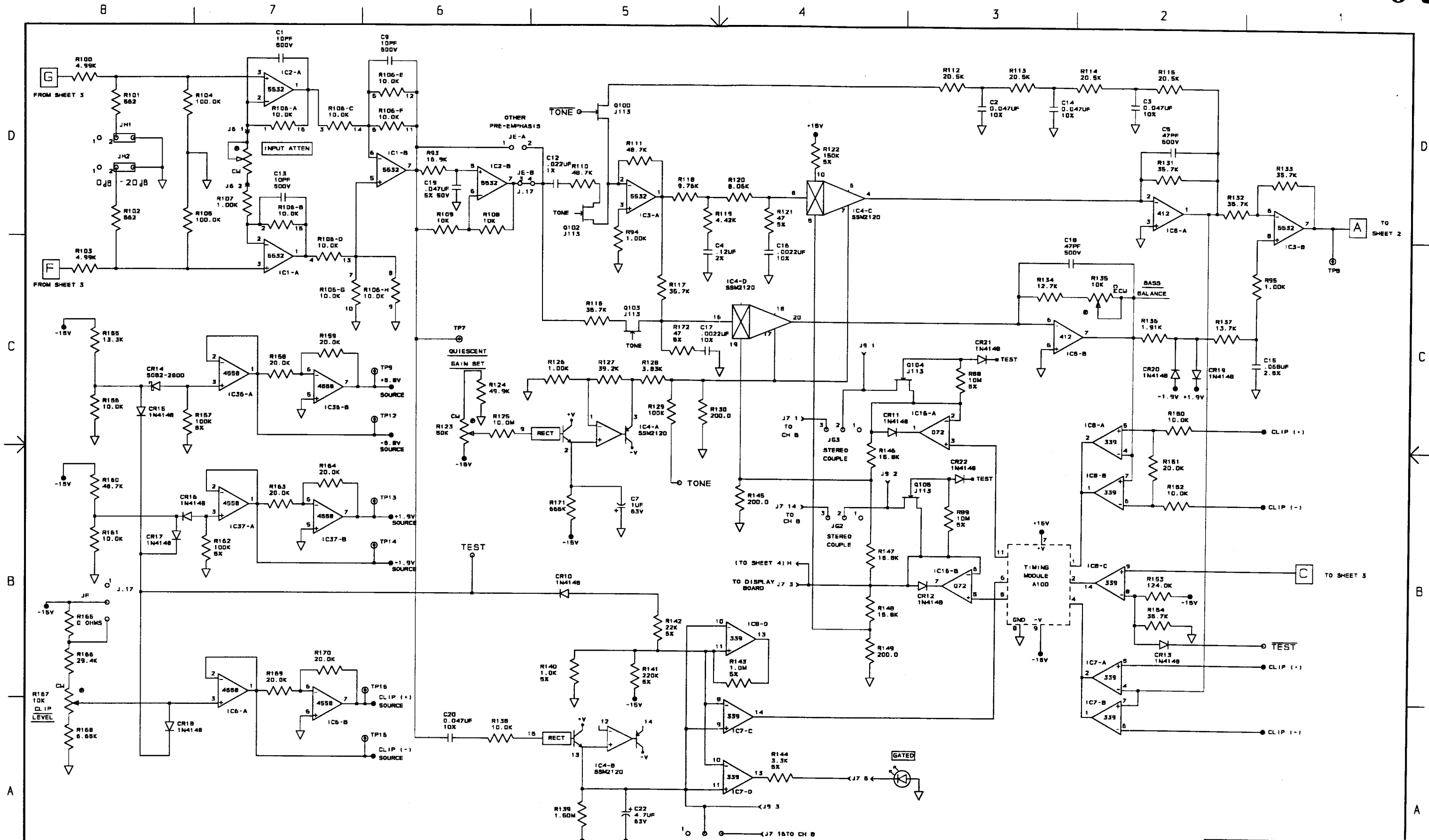

1. ALL RESISTORS ARE 1/8W, 1% CF  
 NOTES: (UNLESS OTHERWISE SPECIFIED)

<b>orban</b>		PROJECT	CAM-1	TITLE	SCHEMATIC			
APPROVALS	DATE			CAM-1				
D&N	WR	12/94						
CKD	PC	12/94	SIZE	DWG NO	VER	REV	SHEET	
APPD	PC	12/94	D	61174	000	01	1 of 4	



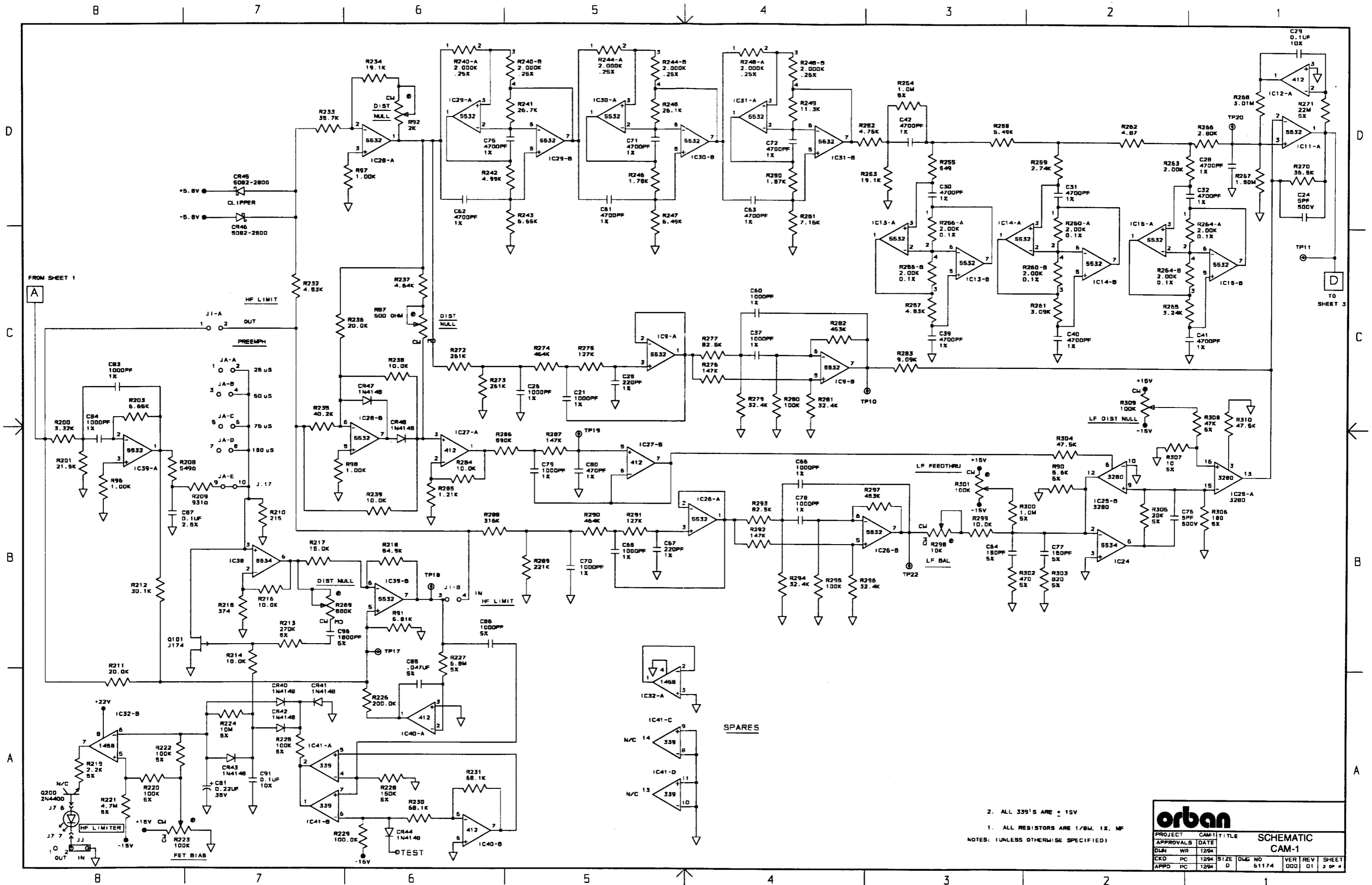

2. ALL 339'S ARE ± 15V  
 1. ALL RESISTORS ARE 1/4W, 1%, MF  
 NOTES: (UNLESS OTHERWISE SPECIFIED)

<b>orban</b>		PROJECT	CAM-1 TITLE		SCHEMATIC	
		APPROVALS	DATE	CAM-1		
DLN	WR	1294	DATE			
CKD	PC	1294	SIZE	DWG NO	VER	REV
APPD	PC	1294	D	61174	000	01
						SHEET 2 OF 4

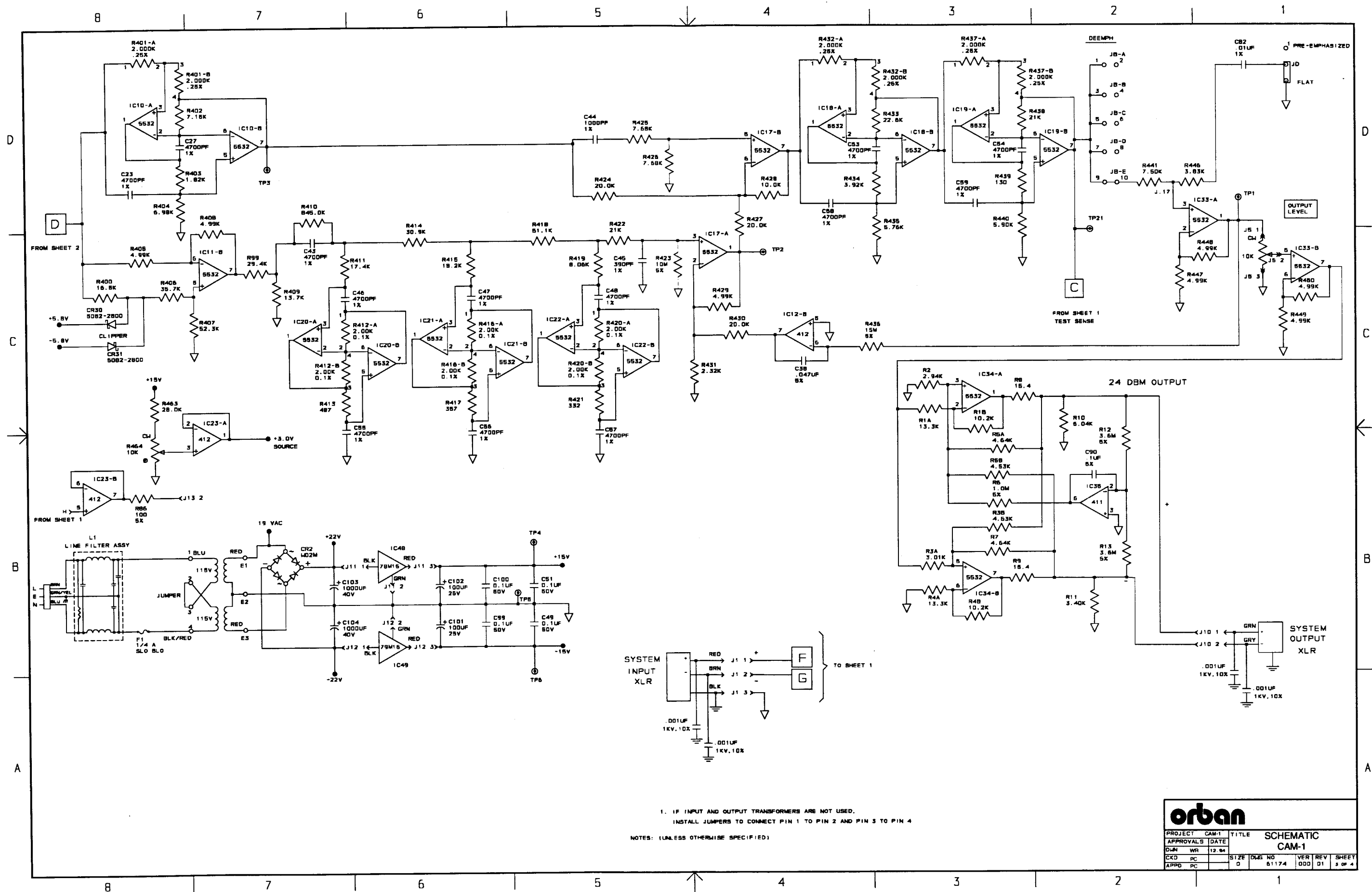

1. IF INPUT AND OUTPUT TRANSFORMERS ARE NOT USED,  
INSTALL JUMPERS TO CONNECT PIN 1 TO PIN 2 AND PIN 3 TO PIN 4

NOTES: (UNLESS OTHERWISE SPECIFIED)

<b>orban</b>		PROJECT	CAM-1	TITLE	SCHEMATIC		
APPROVALS	DATE	DWG	WR	12-84	CAM-1		
CKD	PC	SIZE	DWG NO	61174	VER	REV	SHEET
APRD	PC	D	0	000	01	3	OF 4

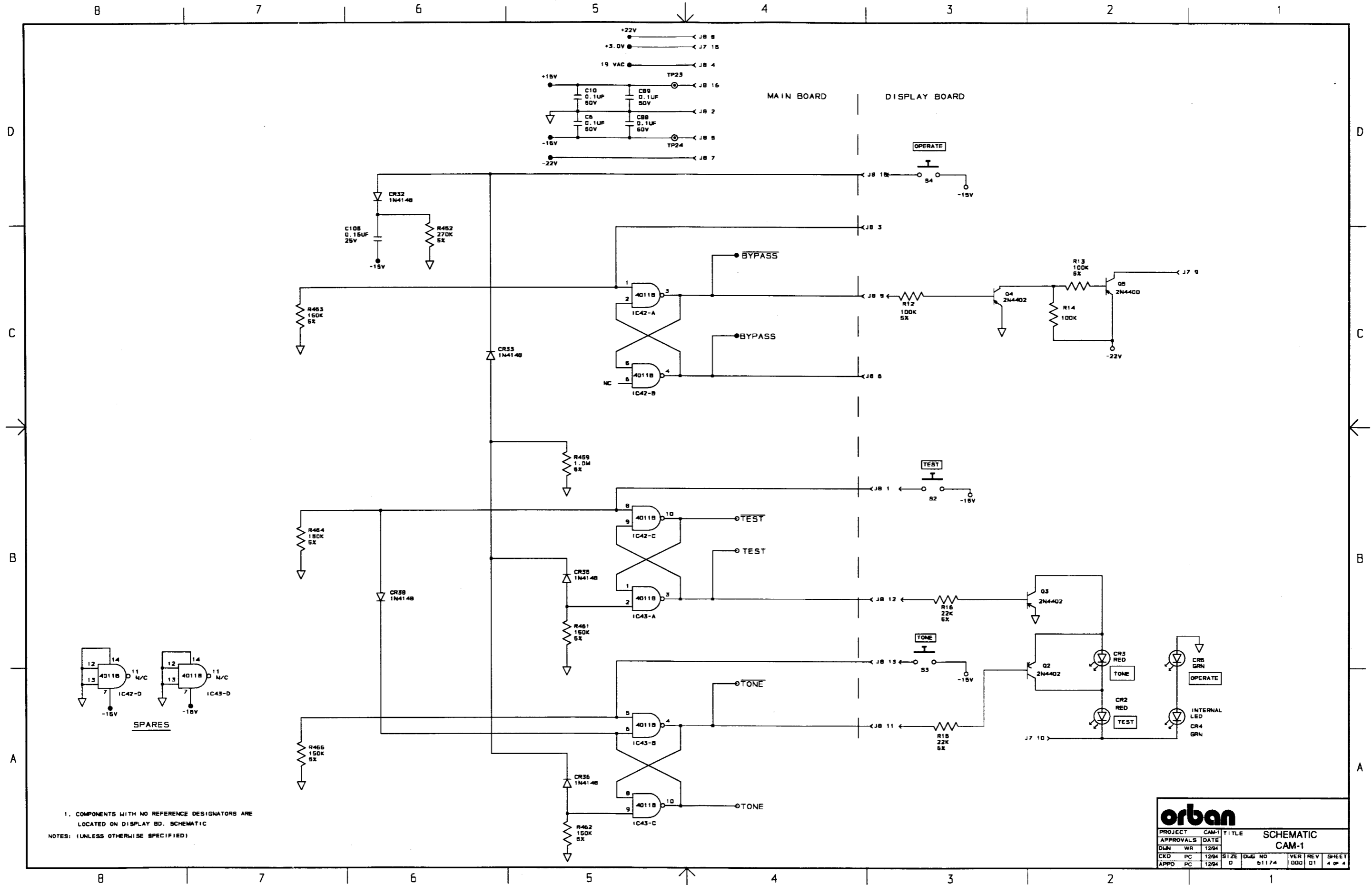

1. COMPONENTS WITH NO REFERENCE DESIGNATORS ARE LOCATED ON DISPLAY BD. SCHEMATIC NOTES: (UNLESS OTHERWISE SPECIFIED)

<b>orban</b>		PROJECT CAM-1		TITLE SCHEMATIC	
APPROVALS	DATE	DATE		CAM-1	
DJN	WR	12/94	SIZE	DWG NO	VER REV SHEET
CKD	PC	12/94	D	51174	000 01 4 of 4
APPD	PC	12/94			

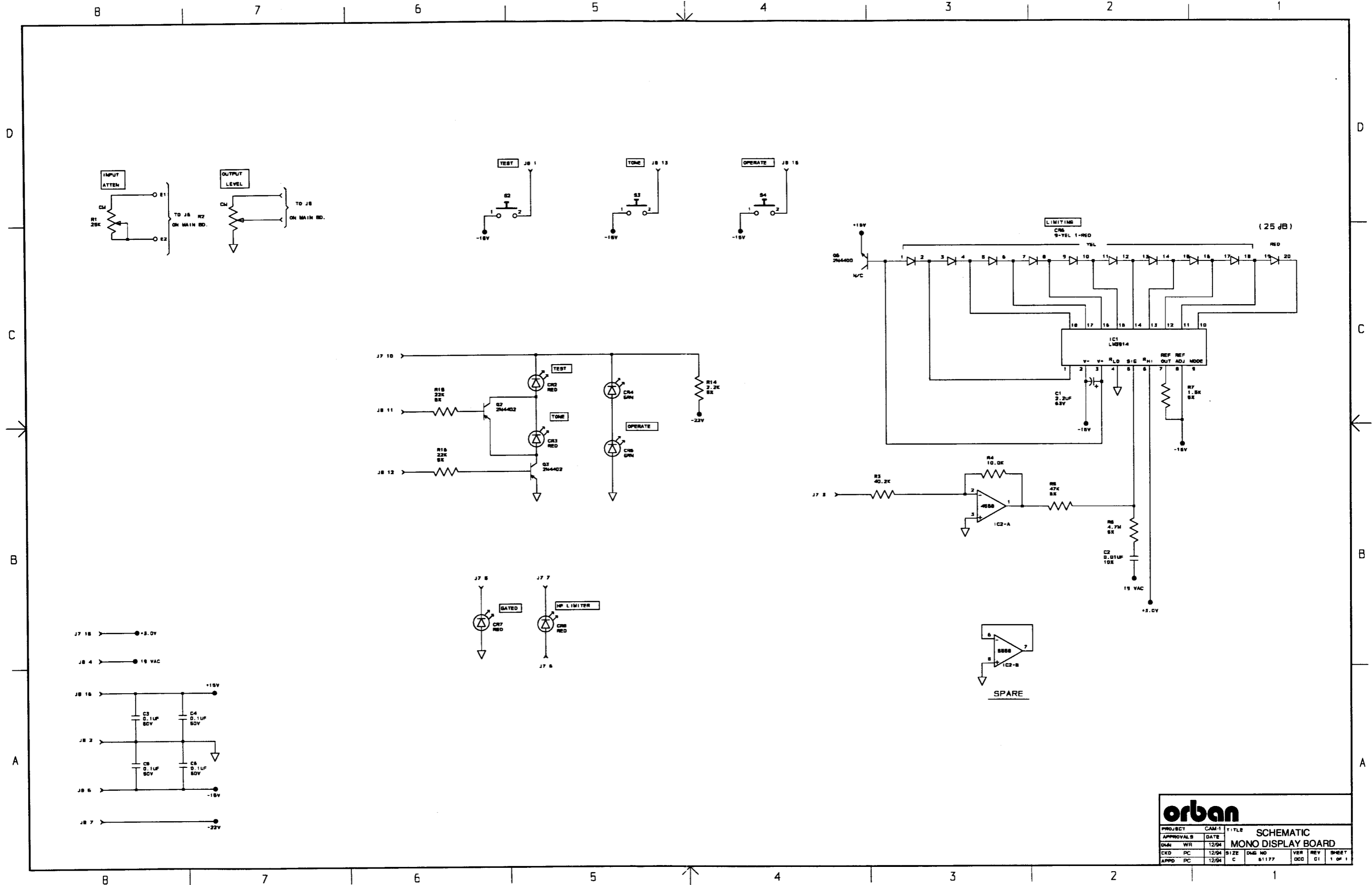

<b>orban</b>		PROJECT	CAM-1	TITLE	SCHEMATIC				
APPROVALS	DATE	DATE	12/94	SIZE	MONO DISPLAY BOARD				
CHKD	PC	12/94	PC	SIZE	DWG NO	61177	VER	REV	SHEET
APPD	PC	12/94	PC	SIZE	C	61177	000	01	1 OF 1

## Abbreviations

Some of the abbreviations used in this manual may not be familiar to all readers:

AGC	automatic gain control
dBm	decibel power measurement. 0dBm = 1mW applied to a specified load. In audio, the load is usually 600Ω.
dBu	decibel voltage measurement. 0dBu = 0.775V RMS. For this application, the dBm-into-600Ω scale on voltmeters can be read as if it were calibrated in dBu.
DJ	disk jockey, an announcer who plays records in a club or on the air
EMI	electromagnetic interference
FCC	Federal Communications Commission (USA regulatory agency)
FET	field effect transistor
FFT	fast Fourier transform
G/R	gain reduction
HF	high-frequency
HP	high-pass
IC	integrated circuit
IM	intermodulation (or "intermodulation distortion")
JFET	junction field effect transistor
LED	light-emitting diode
LF	low-frequency
LP	low-pass
MHF	midrange/high-frequency
MLF	midrange/low-frequency
N&D	noise and distortion
RF	radio frequency
RFI	radio-frequency interference
RMS	root-mean-square
TRS	tip-ring-sleeve (2-circuit phone jack)
THD	total harmonic distortion
VCA	voltage-controlled amplifier
XLR	a common style of 3-conductor audio connector