

ELECTRONIC MUSICAL INSTRUMENT

REVO SOUND SYSTEMS

Revo 30

**SERVICE
NOTE**

THE 1st. EDITION

Printed in Japan. '75. Oct.

 **Roland Corporation**

CONTENTS

SECTION 1.	SPECIFICATIONS	1
SECTION 2.	FUNCTIONS	2
SECTION 3.	ADJUSTMENT AND CHECKING	8
SECTION 4.	CIRCUIT BOARD ASSEMBLY & GENERAL SCHEMATIC DIAGRAM	19
SECTION 5.	PARTS LIST	27

SECTION 1. SPECIFICATIONS

Speed selector switch	1
(STOP/SLOW/FAST)	
Modulation depth selector switch	1
(SOFT/MEDIUM/DEEP)	
Balance control	1
Power switch	1
Speed adjuster	1
Organ input	1
Low level input	1
Speaker terminal (Right)	1
(Left)	1
SEMI-CONDUCTORS IC's	9
Pack (IC3/Transistor 2/ FET 2)	1
Transistors	11
FET's	2
Diodes	26
Light emitting diodes	2
DIMENSIONS W: 183 mm (7.2")	
D: 305 mm (12.0")	
H: 131 mm (5.2")	
Weight (Net) : 4.2 Kg (9.2 Lbs.)	
Output power : 30W R.M.S.	
Power consumption: 80W	

ACCESSORIES

Input cord (3m Connection Cord: ORGAN-REVO-30)	1
Speaker cords (3m Connection Cord: REVO-30 - REVO-30S).....	2
Sub-cord (Connection Cord: ORGAN - REVO-30)	1

SPEAKER SYSTEM (REVO-30S)

Speaker	20 cm x 1
Power Capacity: 15W (R.M.S.)	
Impedance	: 8Ω
Dimensions	: 310(W) x 145(D) x 410(H) mm (12.2" x 5.7" x 16.1")
Weight	: 3.9Kg (8.58 Lbs.)

* Specifications subject to change without notice.

SECTION 2. FUNCTIONS

1. Outline

The Revo 30 System consists of three basic circuit boards: ET-4, ET-5(A), and AP-38. The ET-4, which controls the main functions of the system, includes a delay circuit with a BBD (Bucket Brigade Device), a clock oscillator for the BBD, a low frequency oscillator with a wave former, a limiter, and a low-pass filters. The ET-4 modulates the input signal from the organ and feeds it to the next stage, the ET-5(A), where the signal is modulated again in a specially designed device, BX-11(A), and separated into two separate signals for the AP-38. The AP-38 contains two amplifiers for the two signals, and the system power supply.

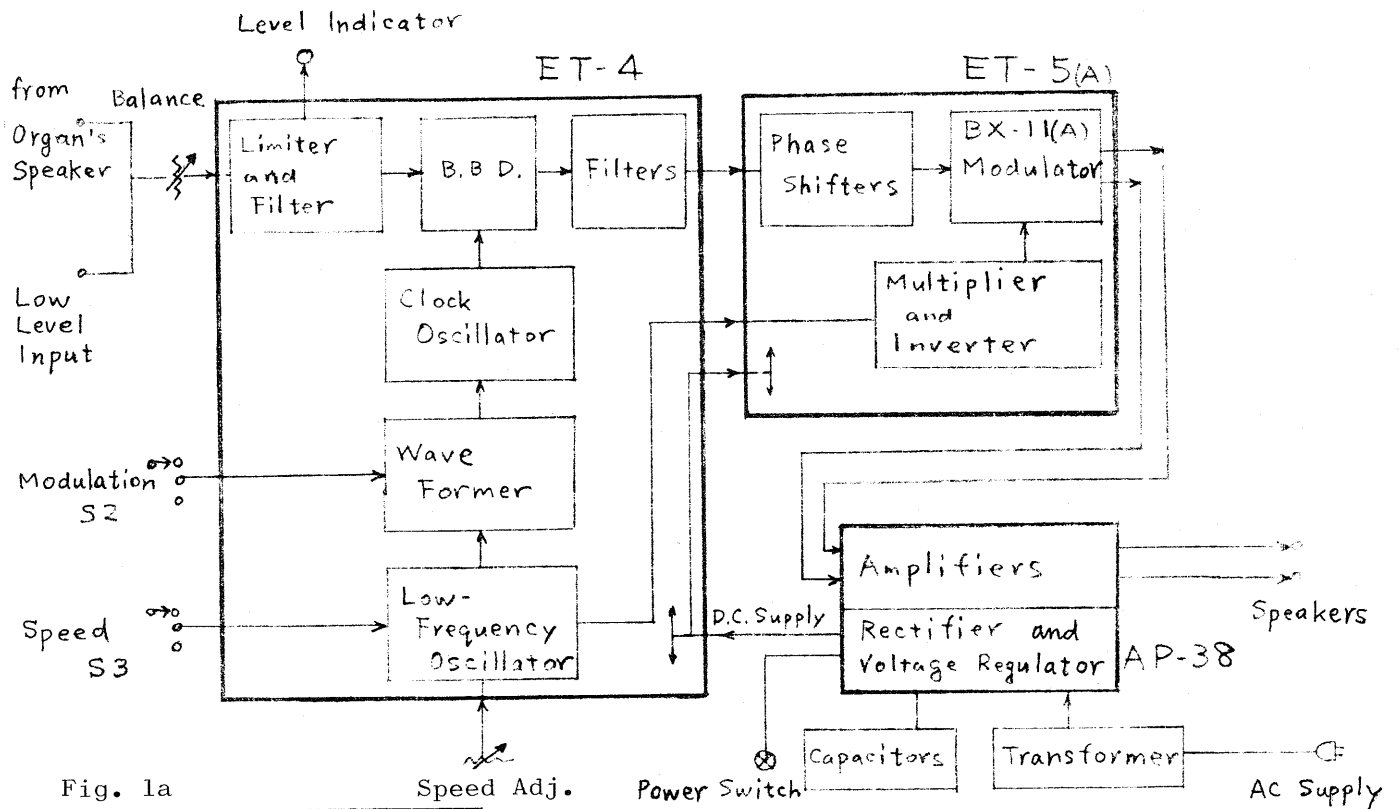

Fig. 1a
Revo.30 Block Diagram

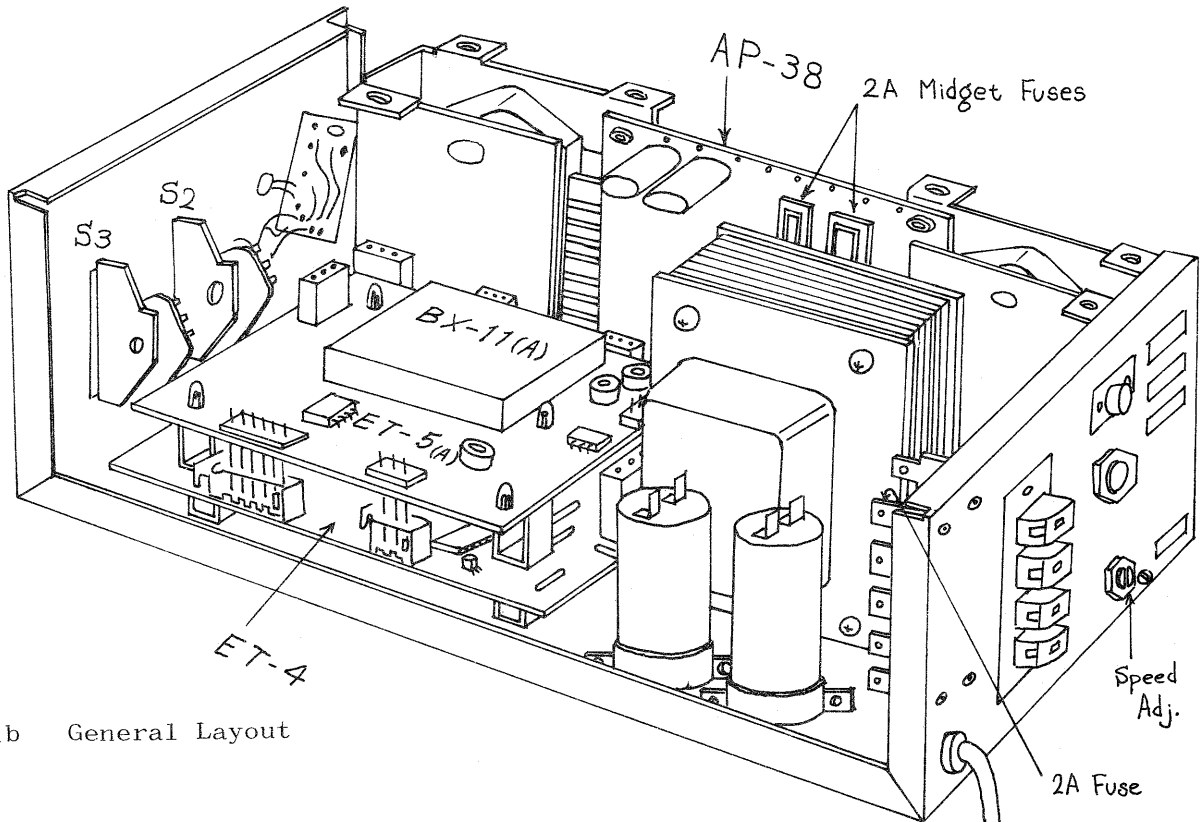

Fig. 1b General Layout

2. ET-4

The musical signal passes through the input terminals and the balance control and enters the ET-4 at terminal No. 1. IC₁, the first stage on the board, acts as a low-pass filter with C04 (47pF) and C03 (470p) to prevent a differential beat frequency between the high frequencies of the signal and the clock oscillator output. It also acts as a limiter in conjunction with the photo coupler Ph1 to prevent distortion in the BBD when the input signal is too strong.

D01, D02, Q2, and Q3 are elements of a detector for the LED in the photo coupler. If the amplitude of the output signal of IC1 goes over a certain level (about 4v p-p), Q2 conducts through the LED, which causes the resistance of the CdS to decrease, and, by means of the feedback loop to IC1, reduces the gain of IC1. Thus, automatically

limiting the amplitude of the incoming music signal to a predetermined level. Q3 is a phase inverter which allows the detector to operate on both halves of the signal.

Q1 is an amplifier for the peak level indicator which illuminates when the input signal reaches the level at which the detector just begins to operate.

The signal filtered and limited in IC1 goes directly to three different places: directly through terminal 28 to the ET-5(A); to IC2 (the BBD), and to one of the active filters. A BBD is a kind of delay circuit. It works with a pair of high frequency clock pulses generated by Q4 and Q5. This frequency, which is high above normal hearing range, is modulated by a low frequency signal (near 0.7 Hz or 7 Hz) generated in IC5.

IC4 is a wave former which converts the low frequency triangular wave generated by IC5 to more approximate a sine wave.

IC4 is the wave former. When the SPEED switch is in the SLOW position (0.7 Hz), Q6 is at cut-off, and IC4 has very little effect on the triangular wave generated by IC5. In FAST position (7 Hz) however, Q6 conducts and IC4 converts the triangular wave to almost a sine wave.

C28 and related resistors and diodes cause the changes between SLOW, and FAST to be gradual and natural.

The MODULATION switch (S2), connected between terminal 9 and 10, changes the amplitude of the LF signal so that the degree of modulation in the BDD varies.

IC3b is an active filter for removing the high-frequency clock pulses from the BBD. It also mixes the BBD modulated signal with the original signal from IC1. The filtered and mixed signal goes to terminal 27, and also to part of IC2 (BBD) where it is modulated in a more complex manner. The doubly modulated signal then goes to terminal 25 via the active filter IC3a.

The LFO also supplies a low frequency square wave (terminal 21) and a low frequency triangular wave (terminal 20) for the ET-5(A). Also the regulated positive and negative DC power supply voltages are distributed from this board to the ET-5(A) board.

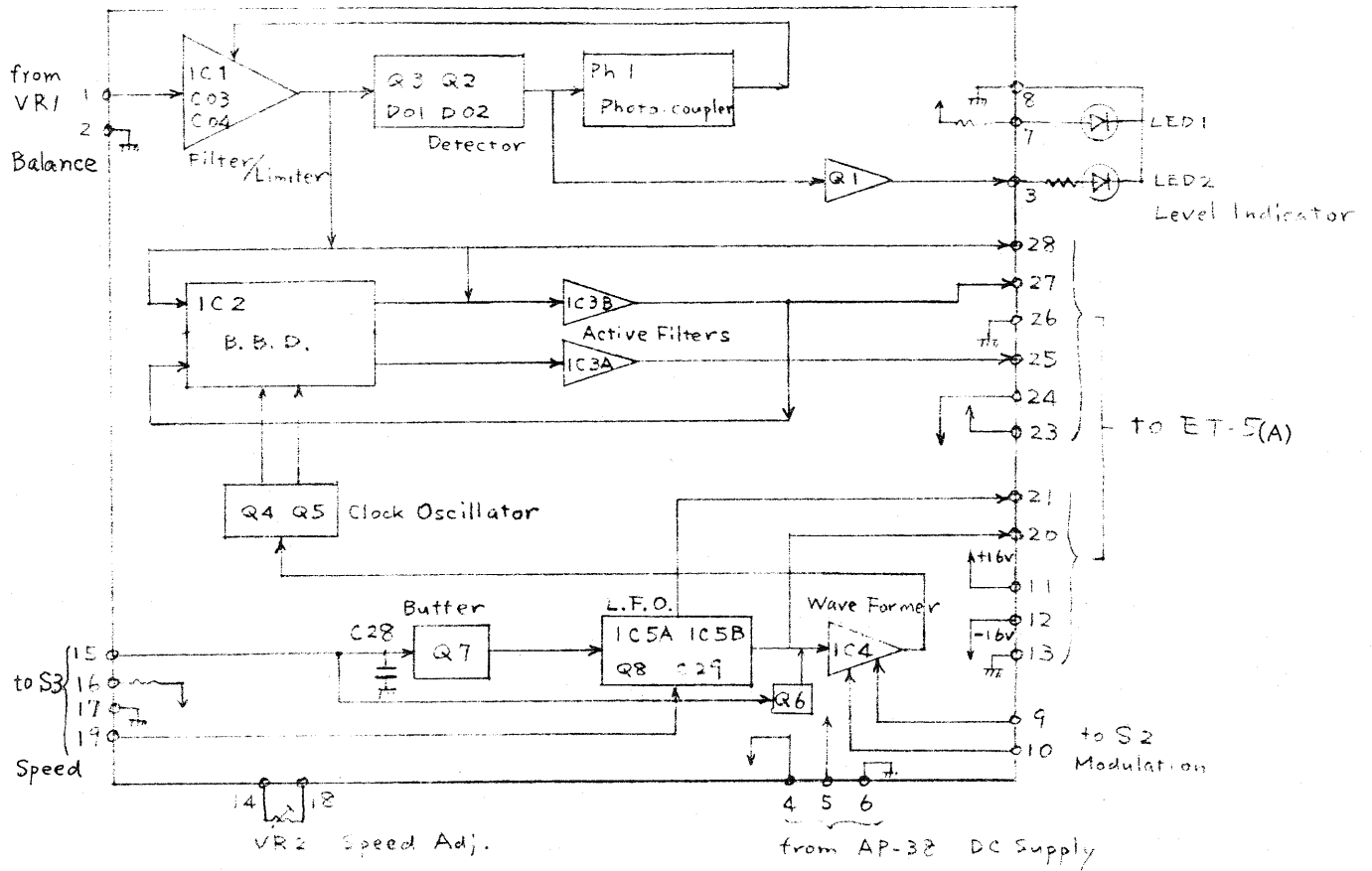

Fig. 2a ET-4 Block Diagram

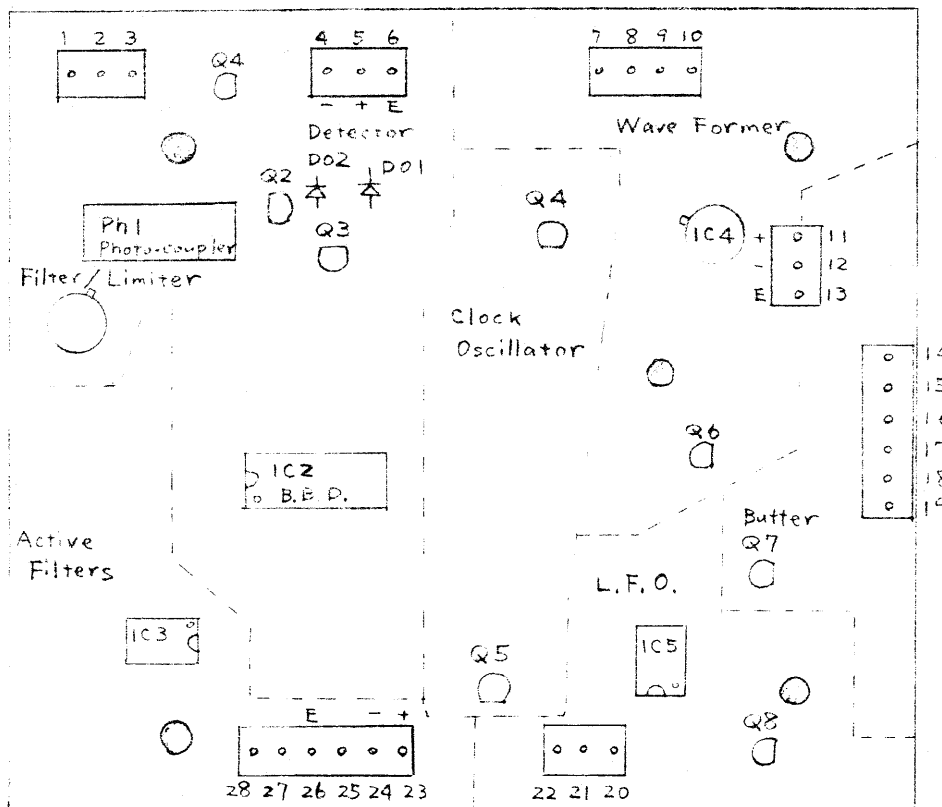

Fig.2b ET-4 Layout

3. ET-5(A)

The signals from ET-4 are fed in two channels to BX-11A through two halves of an IC (IC11A and IC11B).

The three audio signals from the ET-4 pass through IC11 and go in two channels to BX-11(A). The two parts of IC11 act as a phase shifter for the unmodulated (by the BBD) signal from terminal 28, the phase being shifted by 90° . IC11A amplifies the BBD modulated signal from terminal 25, and IC11B amplifies the modulated signal from terminal 27.

The low frequency triangular wave from terminal 20 goes to Q12 where it is changes to a square wave, and to IC12A which acts as a frequency doubler. IC12B inverts the output of IC12A. The phase of the LF square wave from terminal 21 is different from that of the output of Q12. As a result, a pair of LF square waves and a pair of frequency doubled LF triangular waves are provided for BX-11(A).

BX-11(A), one of the most important elements in the Revo 30 System, is a kind of distributor specially designed for the system. It modulates the amplitude of each of the two given audio signals with one of the square waves and one of the triangular waves. The two audio signals are then mixed, then re-separated. The output of Q11, a mixer-buffer, joins the two output channels of BX-11(A). Only these final multi-modulated signals can produce the desirable chorus and revolving effects, so, in maintenance and repair work, all audio routes should be considered because trouble with even one will spoil the effect.

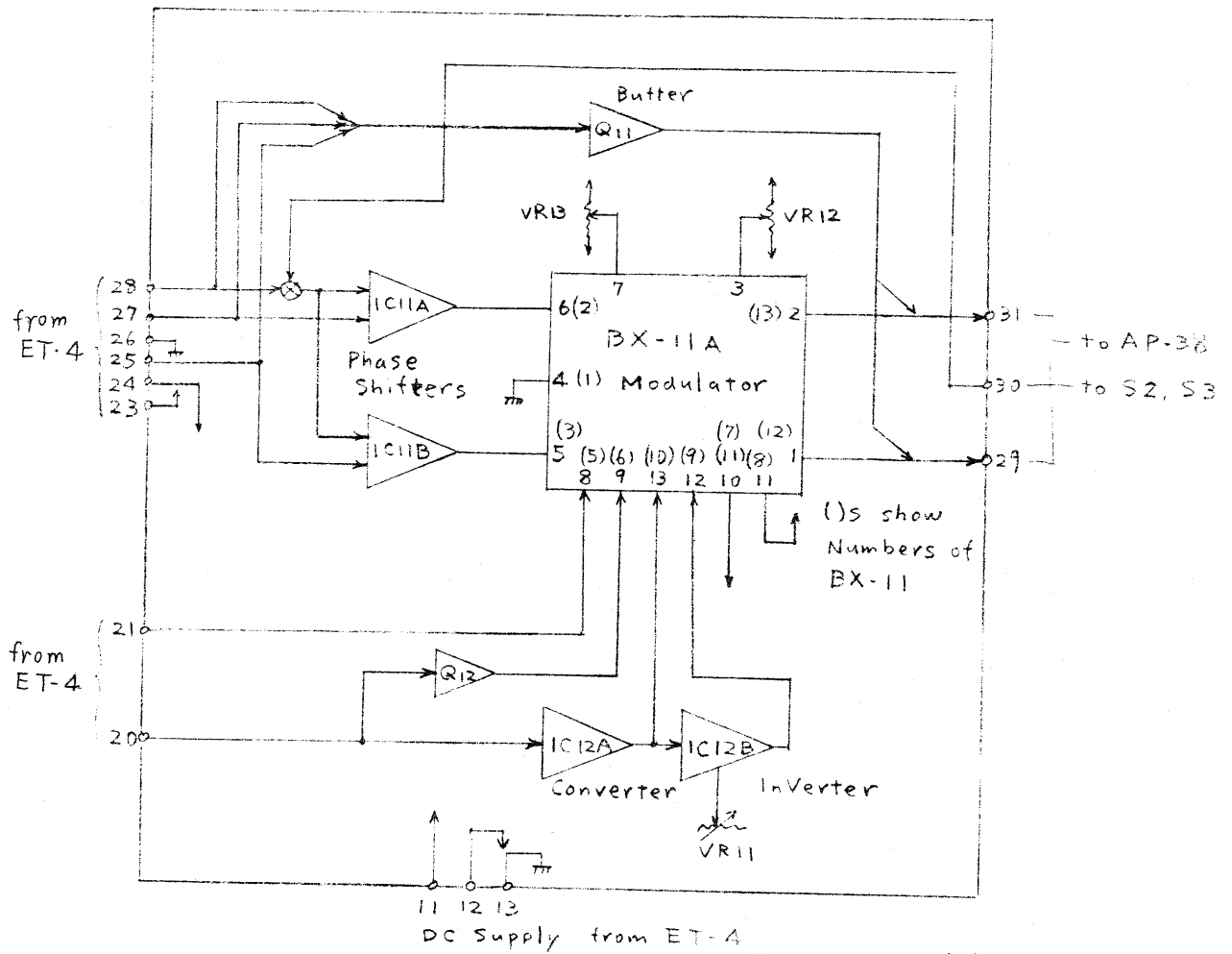

Fig.3a ET-5(A) Block Diagram

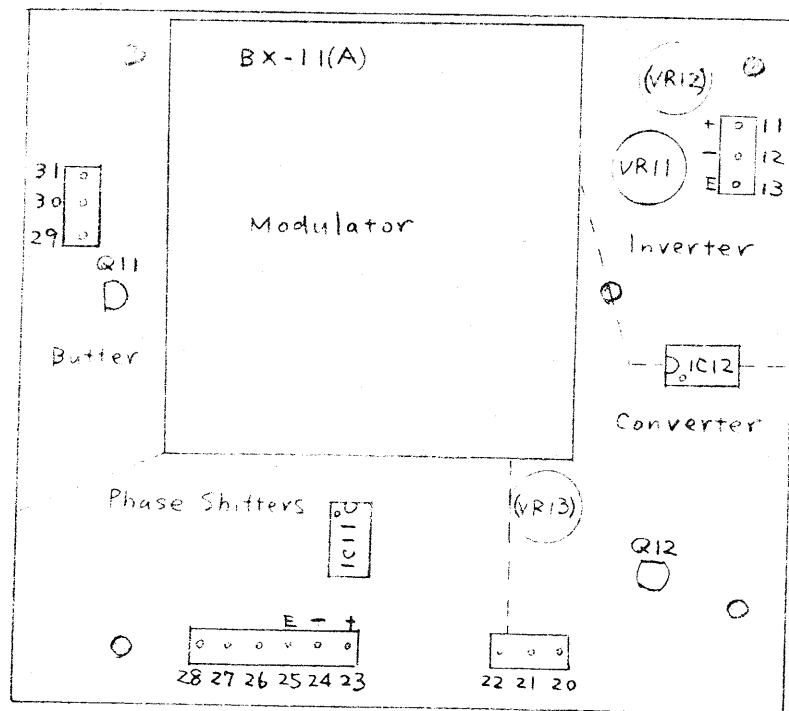

Fig. 3b ET-5(A) Layout

4. AP-38

This board includes two ICs with heat sinks which act as two amplifiers for the two channel output of ET-5(A). Each IC can develop 15 watts of output power without distortion which is enough power to match the original sound from the organ.

The other parts of the board include a rectifier and a voltage regulator which supplies 16V DC both positive and negative.

5. Revo-30S

Revo-30S is a pair of speakers which are provided only for the Revo-30 effect. The specially designed acoustic boxes and speakers make a particularly effective sound and let the Revo-30 exhibit its full capabilities.

SECTION 3. ADJUSTMENT AND CHECKING

1. Sequence of checking

When trouble occurs with Revo-30, it is advisable to check as follows :

If there is no sound, check that cords are connected with power supply, speakers, and organ. If these connections are correct, the trouble must be inside the unit. Unscrew the bottom of the cabinet and take the chassis assembly out. Check the fuses on AP-38 and the fuse on the inside of the back. If any fuse has failed, do not replace it before finding the cause. Short-circuiting of speaker cords often causes fuse failure. Never use fuses rated higher than the values indicated.

If the unit produces sound but it is presumed that there is a trouble in the modulation, check the next sequence.

2. Low frequency oscillator

If you can hear slow and fast rotation effects from the speakers when you operate the speed lever, then the low frequency oscillator is working well. To check it, connect an oscilloscope to terminal 20 or 21. The proper wave forms for these terminals are shown in Fig. 4a and Fig. 4b.

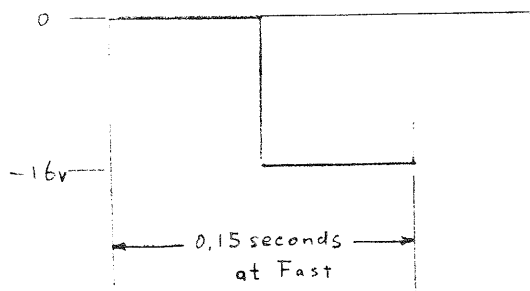

Fig. 4b Terminal 21

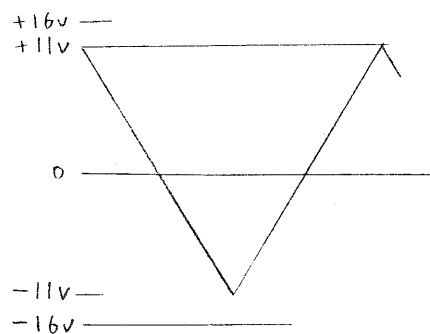

Fig. 4a Terminal 20

Set the Speed lever at Fast, and with the oscilloscope on internal synchronized horizontal sweep, measure the duration of one cycle. A Speed Adjuster (VR2) on the back of the chassis is provided for fine adjustment of effect speed. The factory adjustment is one cycle at 0.15 seconds at Fast which means the frequency of the oscillation is about 6.7Hz - a normal vibrato speed. Turning VR2 clockwise increases the speed chosen by the Speed lever, and counterclockwise decreases the speeds. To change the speed even more, increase or decrease the value of R48 (10K Ω).

Move the Speed lever from Fast to Slow, and you will find that the speed becomes gradually slower. The speed change time depends on C28, R50 and R49 (see Fig. 18, 19) and takes about 4 seconds. The slow speed is fixed at about one tenth of the Fast speed. The difference of rate between slow and fast depends on the ratio between R65 and R63. Change the Speed lever from Slow to Fast and notice that the speed becomes gradually faster. This time depends on C28 and R49 and takes about 6 seconds.

Change the lever to Stop, if it works well the oscillation immediately stops.

When you turn the lever from Slow to Fast and vice versa, if an unnaturally deeply modulated sound is heard, there is a problem around Q6. R46, D09, R47 and C27 are related to Q6. If the strangeness appears only when changing from Slow to Fast then the trouble will be related with R46. If only when changing from Fast to Slow, the trouble will be related with R47, and if when making changer in both direction, then the problem is related to C27.

3. LF signal on ET-5(A)

Connect an oscilloscope to terminal 21 or to the collector of Q12. The wave swings from zero to about the negative supply voltage (-16V). (Fig. 4b)

The wave at terminal 20, originally oscillated by IC5 on ET-4, swings about $\pm 11V$. (Fig. 4a) Both doubled LF outputs of IC12A, and inverted output of IC12B swing from zero to about 1.5V above the negative supply (see Fig.5) Before checking these wave forms, make sure that the vertical amplifier in the oscilloscope is set on DC. Usually it is advisable to check these kinds of signals with the DC range of the oscilloscope. If the inverted signal does not reach the negative level shown in Fig. 6a, then it does not cut off the function of BX-11(A) which, therefore, produces clicking sounds in the audio outputs. In this case, turn the trimmer VR-11(see Fig. 3b) counter-clockwise. If the inverted signal stays at the low level longer than normal (as in Fig. 6b), it cuts off the function of BX-11(A) longer than normal which stiffens the sound. In this case turn the trimmer VR-11 clockwise.

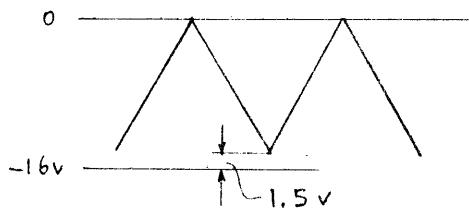

Fig. 5

The output of IC12A is fixed to reach enough of a negative voltage to cut off BX-11(A). There is no adjustment for this. If the output of IC12A is not as expected, there is a possibility that the voltage regulator on AP-38 is not working well due to a drop of AC supply voltage or some other reason.

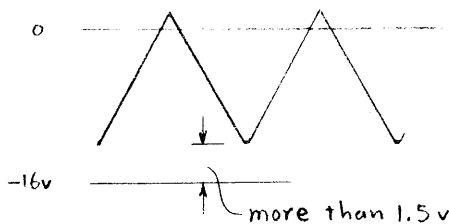

Fig. 6a

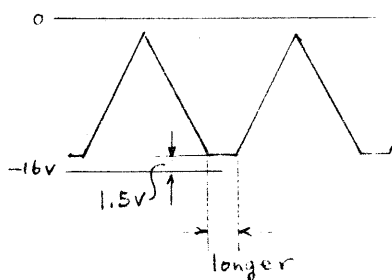

Fig. 6b

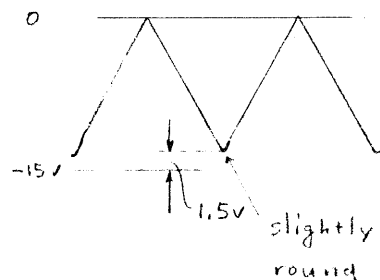

Fig. 6c

4. Modulation on ET-4

With a test oscillator supply a 0.2 Vp-p (0.07V R.M.S.) 1KHz sine wave to the Low Level Input, and check the following points with an oscilloscope synchronized with the input signal. Set the Speed lever at Fast, set the Modulation lever at Medium or Deep, turn the Balance control to the extreme right. (If the horizontal sweep cannot be synchronized with such a low level signal, connect the test oscillator to the pinjack marked "From Organ's Speaker" and supply 1.5Vp-p and synchronize the sweep with this signal.)

Check each point indicated in Fig. 7.

Check that both amplitudes and wave forms are correct.

Turn the input signal up to a level where the peak level indicator above the Balance control on the from panel just begins to illuminate, and measure the input level. Normally it is fixed at about 0.4 - 0.6Vp-p. Increase the input signal to approximately 2Vp-p and check that the voltage at terminal 28 stays around 4Vp-p which is just over the level of terminal 28 when the peak-level indicator begins to illuminate. Also check that the three outputs (terminal 28, 27 and 25) do not have serious distortion. If terminal 28 is distorted, the IC1-Ph1 circuit may have a problem. If there is distortion at terminal 27, one of the DC voltage of IC2(BBD) or the BBD itself may be bad. One possibility is that there is a difference between the absolute voltage of positive and negative supplies. (They should be within 0.5V difference of each offer.)

To check the value of modulation at each position of the Modulation lever and the Speed lever, supply a

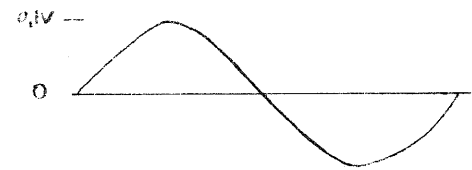

Input Signal

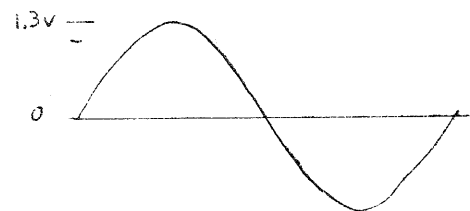

Terminal 28

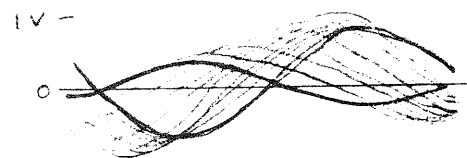

Terminal 27

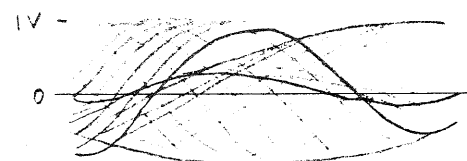

Terminal 25

Fig. 7

40Hz square wave to the input terminals and synchronize an oscilloscope with the input signal. You will find that t_1 equals t_2 in Fig. 8 and they change corresponding to the position of the levers.

To check the modulation rate more closely, you have to remove the ET-5(A) board from the ET-4 board, and connect an oscilloscope to the collector of Q4 or Q5. If the oscillations stop because of the shock

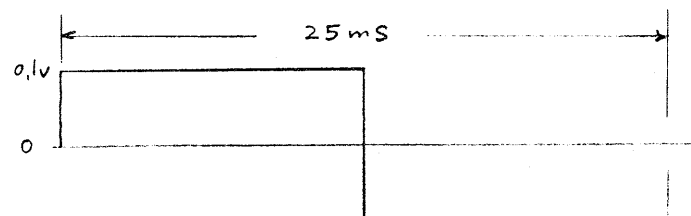

Input Signal

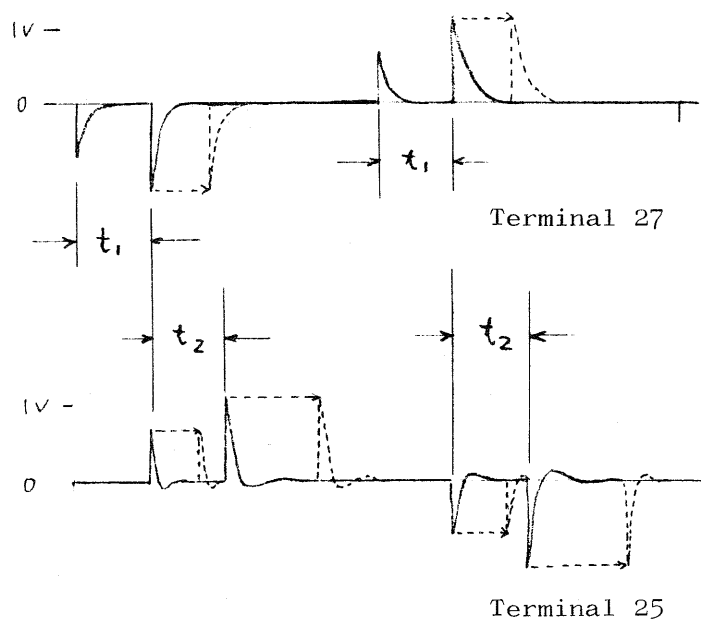
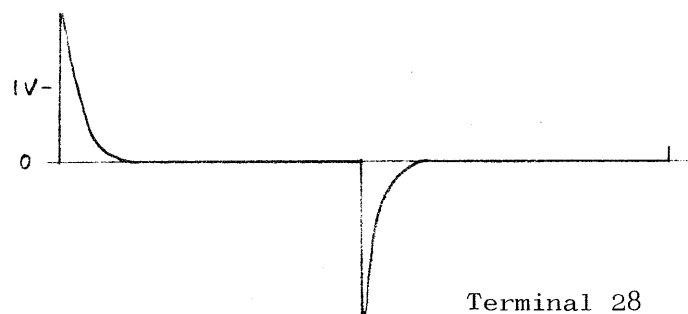

Fig. 8

of the connection, turn the power switch off and wait a few seconds then turn it on again. The wave swings between zero and the voltage of the negative supply. The period of one cycle of the oscillation in the modes of the levers varies approximately as follows;

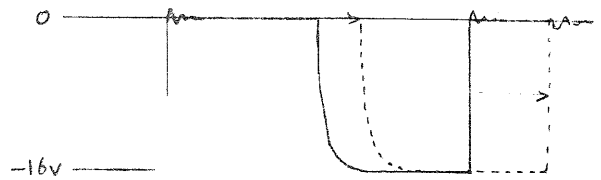

Fig. 9

Modulation Speed	Soft	Medium	Deep	unit
Slow	15 - 20	14 - 21	12 - 23	μ S
Fast	17 - 18	16 - 18	15 - 19	μ S

The output at terminals 27 and 25 should not have clock oscillation leakage. It must be eliminated by the above filters IC3A and IC3B.

5. Modulation on ET-5(A)

For easier checking of this board, it is advisable that the above mentioned checks be completed first. Supply a 40Hz square wave to the input terminals and connect an oscilloscope to terminal 29 or 31. Synchronize the oscilloscope with the input signal, and set the Speed lever at Slow and the Modulation at Deep. Confirm that the wave forms are as shown in Fig. 10.

VR12 and VR13 (see Fig. 3b, not on ET-5) can reduce the low frequency drift when the Speed is set at Fast. It is better to adjust these by listening to the noise output with speakers than by checking it with an oscilloscope. The audible noise is not only related to the amplitude of electrical noise, but also to the wave form.

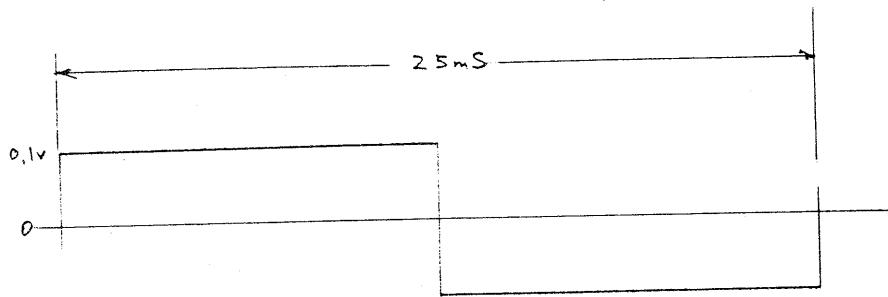

Input at Low Level Input

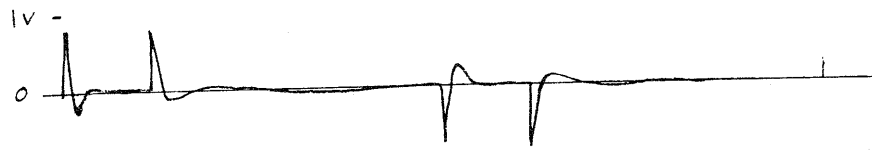

Output of IC11A

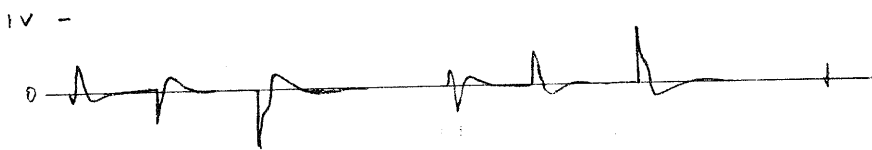

Output of IC11B

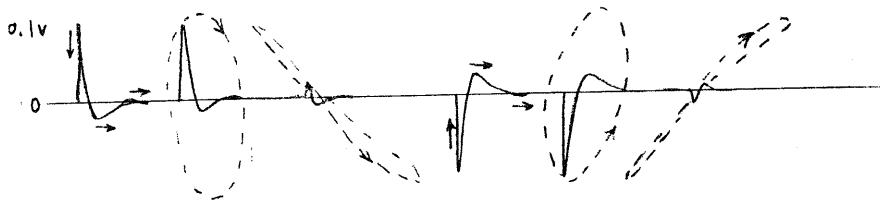

Terminal 29

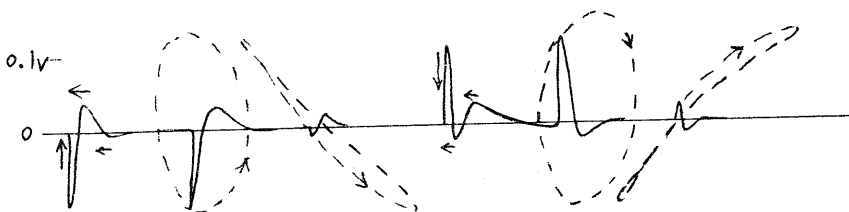

Terminal 31

Fig. 10a Outputs of ET-5

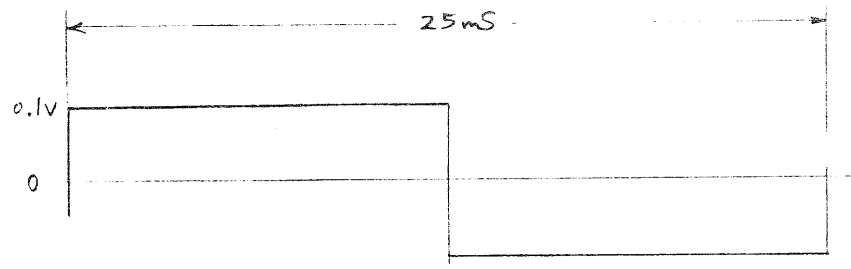

Input at Low Level Input

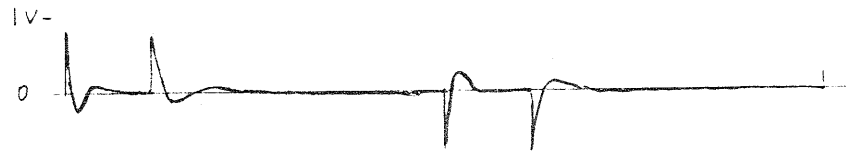

Output of IC11A

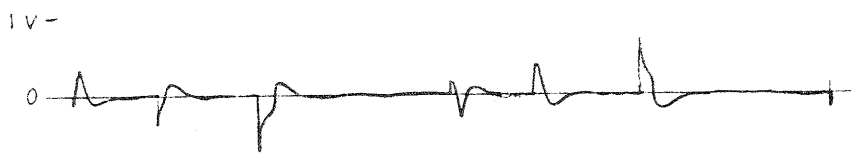

Output of IC11B

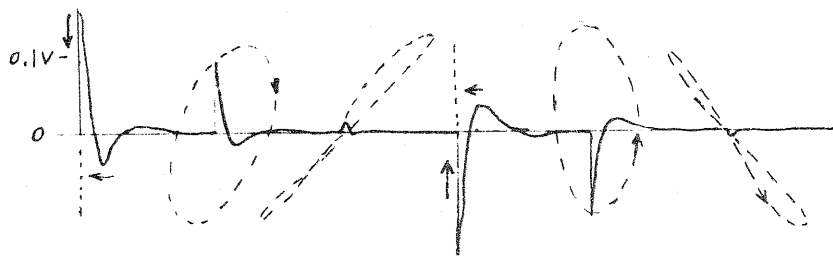

Terminal 29

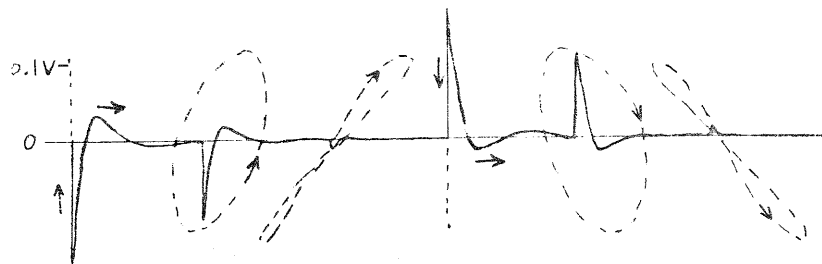

Terminal 31

Fig. 10b Outputs of ET-5A

6. AP-38

There are two trimmers for gain control on the board. To adjust the gain of both channels, supply 2Vp-p 2.2KHz sine wave and set the Balance to the extreme right, the Modulation at Medium, and the Speed at Fast. Connect speakers or dummy loads(8 ohms), and connect an oscilloscope synchronized with output of Q12 on ET-5(A) to each of the speakers or dummy loads in parallel. Tune the frequency of the oscillator so that the maximum peak level is obtained. Then turn one of the trimmers up for each channel, until the peak level just reaches the clipping level. Make sure that no part of the wave is clipped at any frequency from 1KHz to 3KHz.

Check that the regulated DC supply shows equal positive and negative values. The difference between both absolute voltages should not exceed 0.5V. The voltages themselves depend on the zener diode D303 (of which are limited to $16V \pm 5\%$)

7. Complete system

Revo-30 has only a few points for adjustment. If it has been checked in the previously mentioned ways, it should work well. The conditions around it, including size of the room, influence the effect the same as for any other musical instrument.

As explained in the instruction manual, installation should be decided by conditions. The Balance control on the panel must be set depending on the installation. Fig.11 shows the degree of Balance control setting needed so that the peak-to-peak voltage of the input which produces maximum output just reaches the shoulder of the characteristic curve of the photo coupler limiter(Ph-1). As an example, consider a spinet type electronic organ which incorporates an 8-ohm speaker and a 25W amplifier.

Following Ohm's law, the maximum voltage output is 40Vp-p.

So, to produce maximum output from the Revo-30 system when the organ radiates 25W of sound, it is proper to take the organ's signal from the speaker via the pin-jack terminal and set the Balance at between 2-3 degree according to Fig.11. However, in actual practice, it is advisable to set the Balance at a little bit to the right for producing a conformable effect. When it is set so, an over driven signal can be limited in the first stage and causes the Peak Level indicator

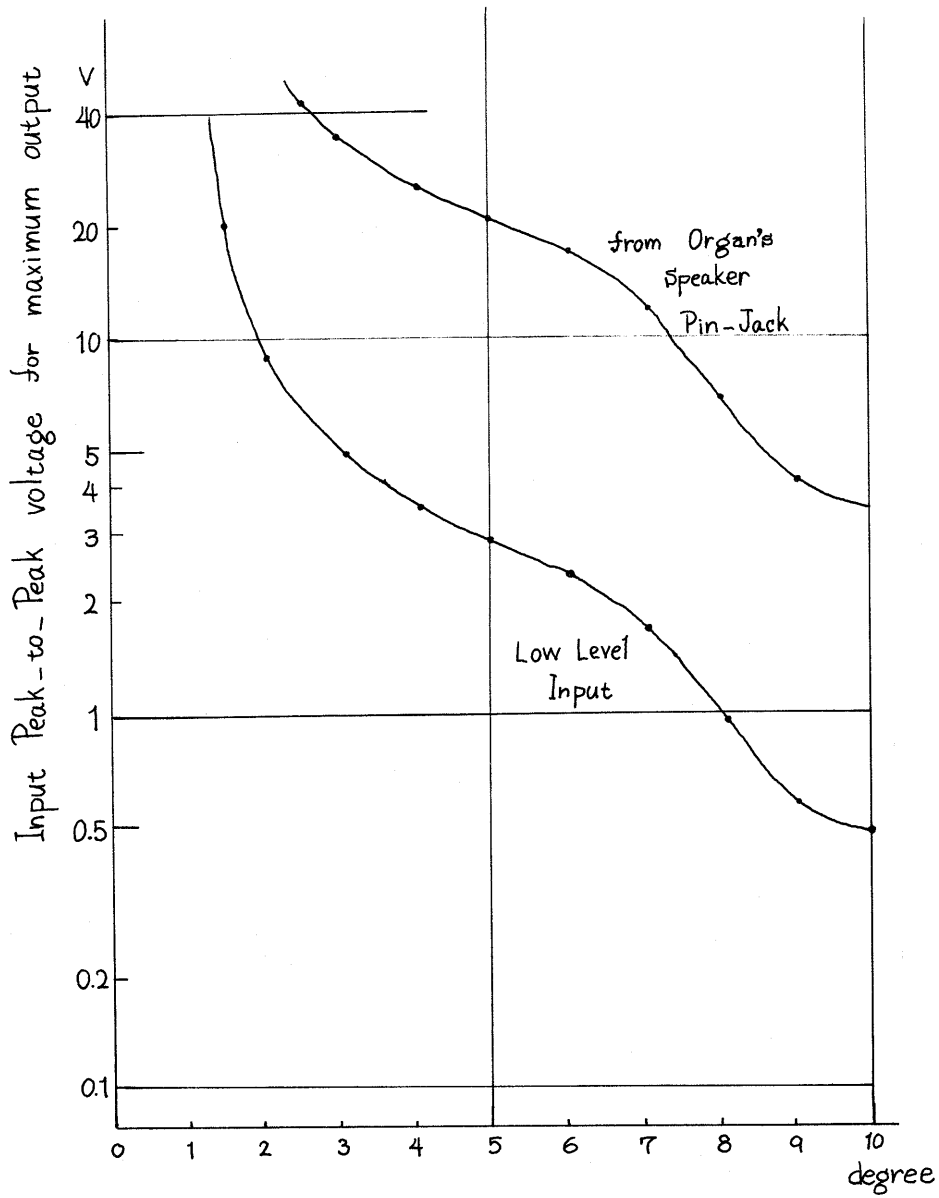

Degree of Balance control

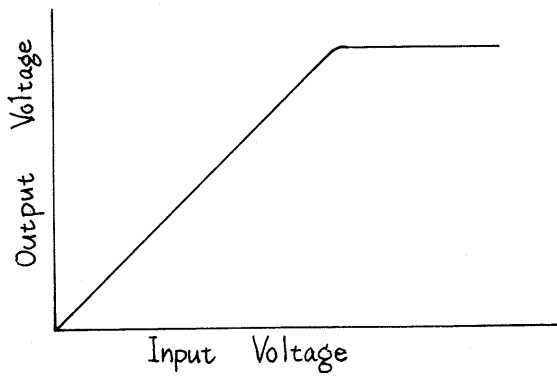

Characteristic of the photo coupler limiter

Fig. 11

to flicker instead of causing extreme distortion. This causes no problem except that the Revo sound does not increase very much when the organ is played fortissimo.

If the organ has two or more speakers, it must be decided where to get the signal from. If one is a tweeter which is connected with a woofer through only a capacitor, there will be no problems in connecting the clips of the Input Cord to the terminals of the woofer. If the signal is distributed to the speakers through a capacitance-inductance network, the clips should be connected directly to the amplifier or to the input terminals of the network, otherwise, if the Revo-30 were connected to one of the speakers, the network would block high or low frequency signals depending on which of the speakers the clips were connected to.

Although the Revo-30 System is designed for use with spinet type organs, it can also be used with Combo-organs if a separate amplifier is used as shown in Fig.12. In the Revo-30 System, low frequencies are cut in order to protect the speakers from large amplitude low frequencies produced by organ pedals so these should be radiated from a separate channel. Also the total Revo effect is much more enhanced when combined with an unmodulated sound source.

The Revo-120 and Revo-250 systems are better suited for Combo type organs (or other type electronic musical instruments which don't incorporate internal power amplifiers) because these systems incorporate a separate channel for unmodulated sound output.

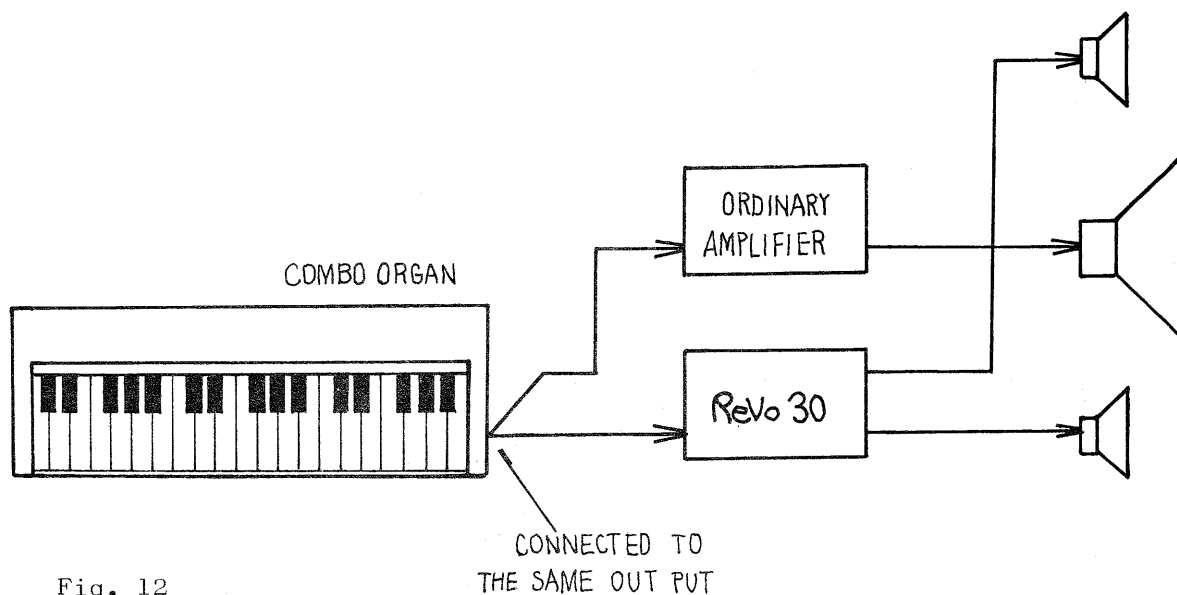
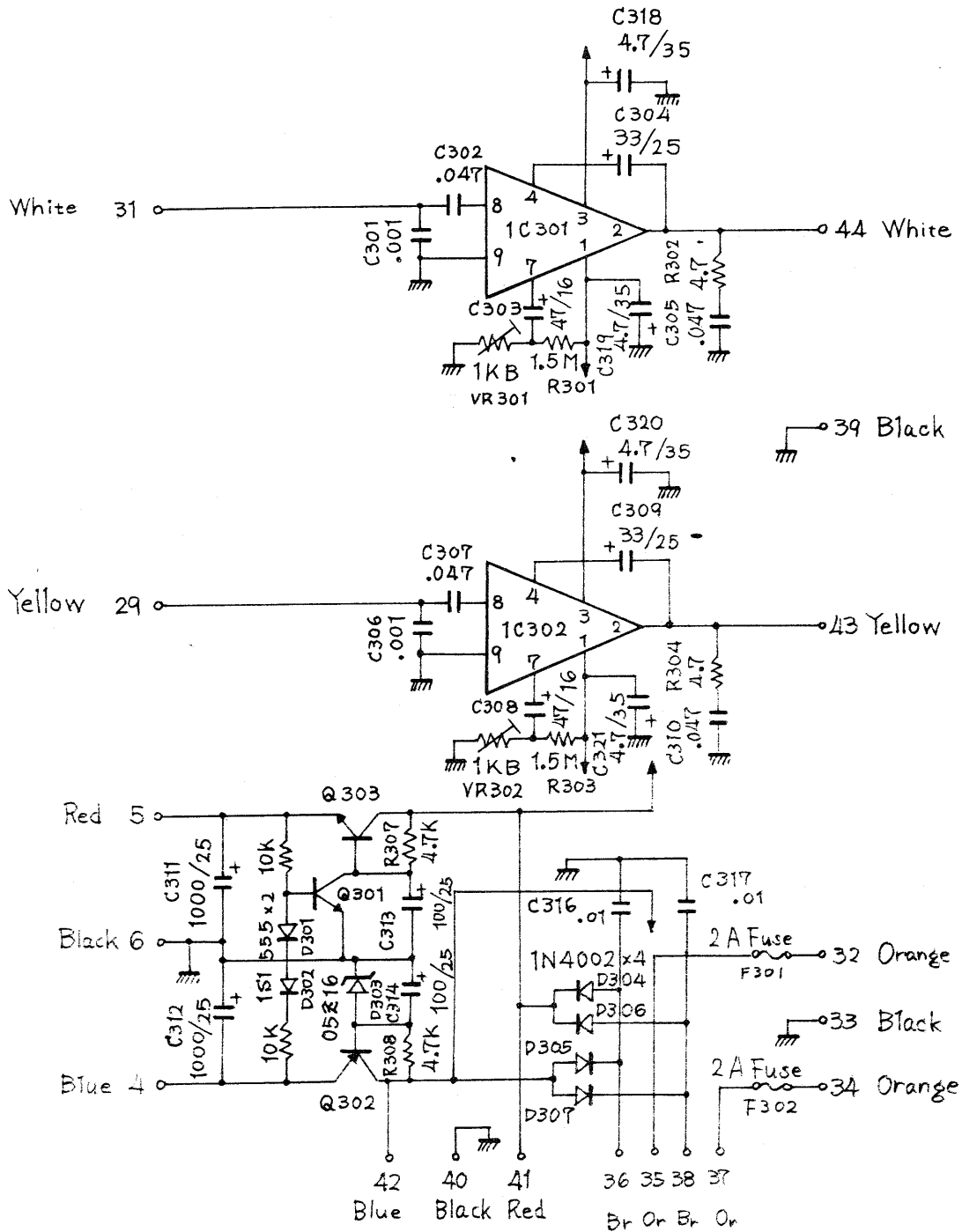

Fig. 12

4-5. CIRCUIT DIAGRAM (AP-38) (Fig. 17)



Q301 is 25C373
 Q302 is 25B434
 Q303 is 25D234

ICs are STK-022, not on the printed board.
 All Resistors are 1/4 Watt ($\pm 5\%$) type.
 All Capacitors marked + are chemical type.
 All Capacitors without + are polyester film type.

4-6. GENERAL SCHEMATIC DIAGRAM

4-6-1. DIAGRAM (A) applied until SERIAL No. 371099 (Fig. 18)

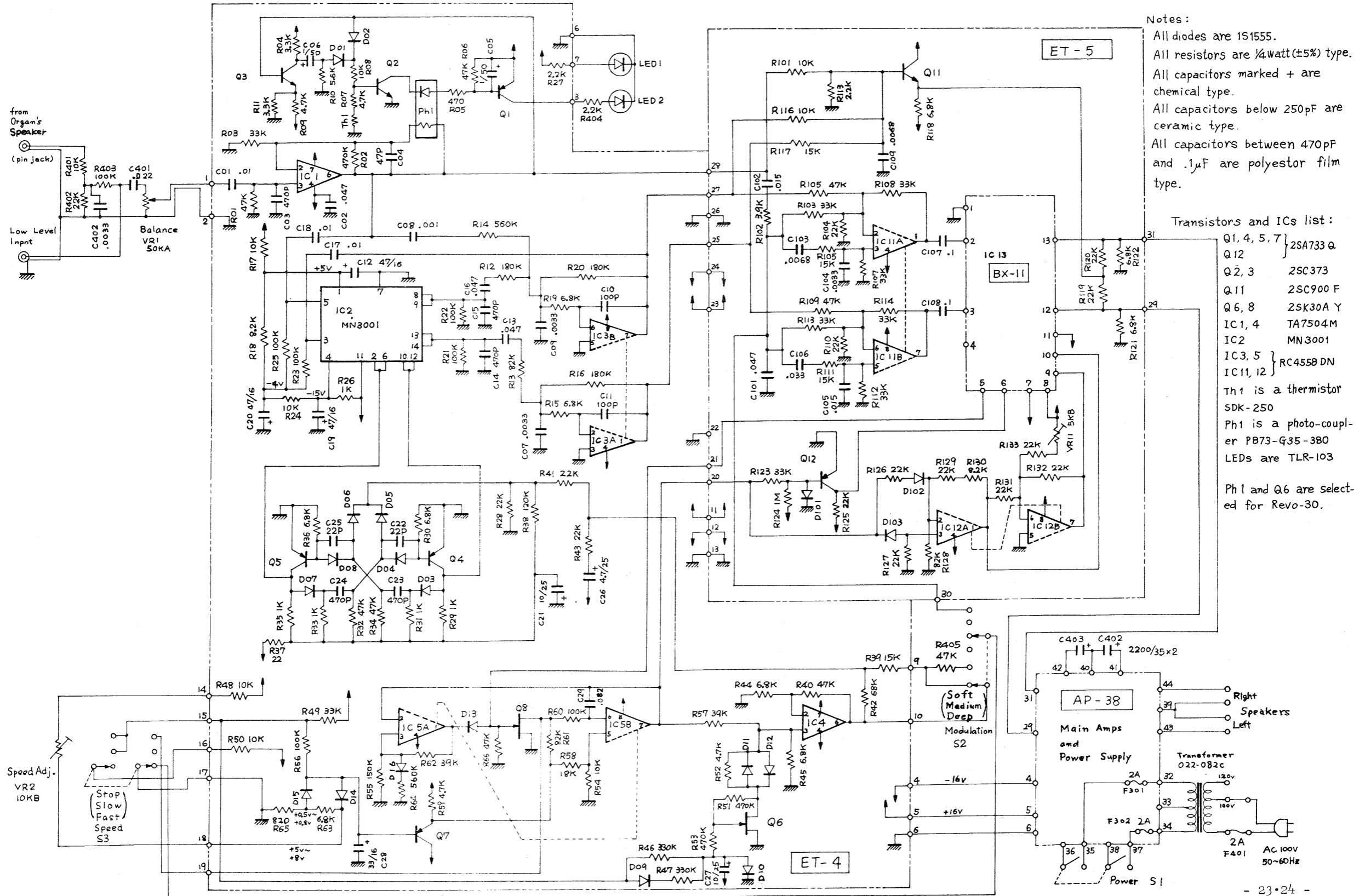

Notes:
 All diodes are 1S1555.
 All resistors are 1/4 watt (±5%) type.
 All capacitors marked + are chemical type.
 All capacitors below 250pF are ceramic type.
 All capacitors between 470pF and .1µF are polyester film type.

- Transistors and ICs list:
- Q1, 4, 5, 7 } 2SA733 Q
 - Q2, 3 } 2SC373
 - Q11 } 2SC900 F
 - Q6, 8 } 2SK30A Y
 - IC1, 4 } TA7504M
 - IC2 } MN3001
 - IC3, 5 } RC4558 DN
 - IC11, 12 } RC4558 DN
- Th1 is a thermistor SDK-250
 Ph1 is a photo-coupler PB73-G35-380
 LEDs are TLR-103
 Ph1 and Q6 are selected for Revo-30.

4-6-2. DIAGRAM (B) applied from SERIAL No. 382000 (Fig. 19)

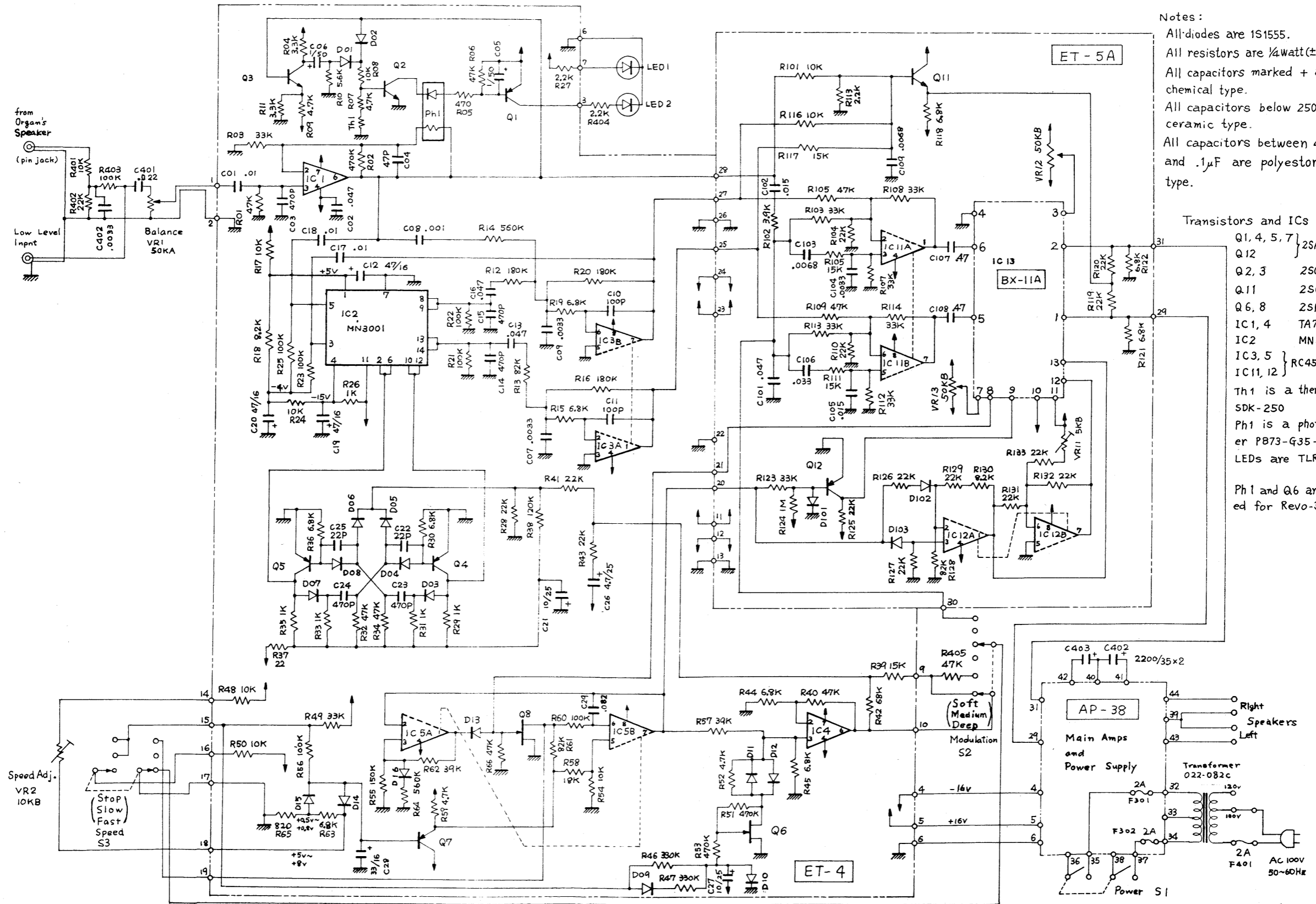

Notes:
 All diodes are 1S1555.
 All resistors are 1/4 watt (±5%) type.
 All capacitors marked + are chemical type.
 All capacitors below 250pF are ceramic type.
 All capacitors between 470pF and .1µF are polyester film type.

- Transistors and ICs list:
- Q1, 4, 5, 7 } 2SA733 Q
 - Q12 } 2SA733 Q
 - Q2, 3 } 2SC373
 - Q11 } 2SC900 F
 - Q6, 8 } 2SK30A Y
 - IC1, 4 } TA7504M
 - IC2 } MN3001
 - IC3, 5 } RC4558 DN
 - IC11, 12 } RC4558 DN
- Th1 is a thermistor SDK-250
 Ph1 is a photo-coupler P873-G35-380
 LEDs are TLR-103
 Ph1 and Q6 are selected for Revo-30.

SECTION 5. PARTS LIST

Caution : Be sure to list the part numbers in addition to these names when you order the replacement parts.

GENERAL ASSEMBLY

081-059A	Cabinet No. 59A (includes Blind No.71, 72)
072-083A	Pannel No. 83A
061-080	Chassis No. 80
022-82C	Power Transformer No. 82C 100-120V
022-82D	Power Transformer No. 82D 220-240V
001-053	Power Switch MS-0664K (Black)
001-077	Lever Switch ESL-18-3S
016-029	Knob (for Lever) No.29
028-083	Potentiometer EVC-BOA S10B14 10KB
028-105	Potentiometer EVC-BOA S15A54 50KA
016-031	Knob(Balance) TK-1100B
009-004	Jack 2P L-2 Close
009-005	Pin Jack TP-201
010-026	Push Terminal(output) 4P
042-004	4-Lug Terminal Strip 2L-4P
008-016	Wired in Fuse (Pin tail) 2A
047-019	Line Cord Strain Relief R-5
047-001	Cord Binder No.11
064-043	Stacking Spacer CBSS-8N
064-045	Stacking Spacer CBSS-12N
064-047	Stacking Spacer MB-1-156
010-028	Housing Receptacle A2139-3
010-008	Housing Receptacle A2139-4
010-009	Housing Receptacle A2139-6
	Pin Terminal 2578T
120-001	Long Nut No.1 3 x 10
053-046	Connection cord (input) Assembly including follows.
	012-014 Capsule F-7175
	044-126 ½ Watt resistor ERC-12GK 1Kohm
	053-045 Patch Cord No. 45 HS-4007 3m(Black)
053-101	Speaker Cord No. 101 00-30
053-116	Cord IP-25

P.C.B. ASSEMBLY

151-004	Effect Board Assembly	ET-4
151-005	Effect Board Assembly	ET-5
140-011	Pack No. 11	BX-11) until SERIAL No. xx0399
151-005A		EX-5A)
140-011A		BX-11A) from SERIAL No. xx0400

ET-5 and BX-11 are discontinued. BX-11A only cannot be replaced for BX-11. BX-11 should be interchanged together with ET-5 to BX-11A and ET-5A.

141-038	Amp. Board Assembly	AP-38 (with ICs-STK022)
---------	---------------------	-------------------------

SEMICONDUCTORS

IC

020-023	STK-022
020-017	RC-4558DN
020-010	TA7504M
020-022	MN3001

FET

017-014	2SK-30A-Y
017-014R	2SK-30A-Y (selected)

Transistor

017-011	2SC-373
017-021	2SC-900 F
017-031	2SA-733 Q
017-022	2SB-434 O
017-010	2SD-234 O

Diode

018-005	1S1555
018-018	1N4002

Zener Diode

018-026	05Z-16A
---------	---------

Light Emitting Diode

019-002	TLR-103
---------	---------

Photo-Coupler

019-006R	P873-G35-380 (selected)
----------	-------------------------

Thermistor

018-025	SDT-250
---------	---------

Nos. with suffix "R" are of selected for REVO-30.

CAPACITORS

Electrolytic Capacitor

032-071	1mfd	50V	ECE-A
032-046	4.7mfd	25V	ECE-A
032-047	10 mfd	25V	ECE-A
032-049	33 mfd	25V	ECE-A
032-051	100mfd	25V	ECE-A
032-055	1000mfd	25V	ECE-A
032-060	4.7mfd	35V	ECE-A
032-035	33 mfd	16V	ECE-A
032-036	47 mfd	16V	ECE-A
032-146	2200mfd	35V	ECE-M35A
032-192	0.47mfd	50V	ECEA-50NR47 (Bi-Polar)

Plastic(Mylar) Film Capacitor

035-001	470 pfd	50V K
035-005	0.001mfd	50V K
035-011	0.0033mfd	50V K
035-014	0.0068mfd	50V K
035-016	0.01mfd	50V K
035-018	0.015mfd	50V K
035-020	0.022mfd	50V K
035-022	0.033mfd	50V K
035-024	0.047mfd	50V K
035-027	0.082mfd	50V K

Ceramic Capacitor

037-003	22 pfd
037-005	47 pfd
037-006	100pfd
037-018	150pfd

RESISTORS

Trimmer Pot.

028-003	EVL-R4XA00	5KB
028-006	EVL-R4XA00	50KB
028-002	EVL-R4XA00	1KB

Carbon Film Resistor

044-009	4.7 ohm	¼ R J
044-017	22 ohm	"
044-033	470 ohm	"
044-036	820 ohm	"
044-037	1 Kohm	"
044-040	2.2Kohm	"
044-042	3.3Kohm	"
044-043	3.9Kohm	"
044-044	4.7Kohm	"
044-045	5.6Kohm	"
044-046	6.8Kohm	"
044-047	8.2Kohm	"
044-048	10 Kohm	"
044-050	15 Kohm	"
044-051	18 Kohm	"
044-052	22 Kohm	"
044-054	33 Kohm	"
044-055	39 Kohm	"
044-056	47 Kohm	"
044-058	68 Kohm	"
044-059	82 Kohm	"
044-060	100 Kohm	"
044-061	120 Kohm	"
044-062	150 Kohm	"
044-063	180 Kohm	"
044-066	330 Kohm	"
044-068	470 Kohm	"
044-069	560 Kohm	"
044-072	1 Mohm	"
044-074	1.5 Mohm	"

SPEAKER SYSTEM (Revo-30S)

081-061	Cabinet No.61 (including rear board)	
041-018	Speaker	20-112Q
010-025	Push Terminal	2P

MISCELLANEOUS

Wafer Terminal

010-035	A2461-3C (ET-4)	
010-036	A2461-4C (ET-4)	
010-037	A2461-6C (ET-4)	
010-039	A2461-3B (ET-5A)	
010-041	A2461-6B (ET-5A)	

Housing Receptacle

010-029	A2145-3C (ET-4)	
010-020	A2145-6C (ET-4)	

012-008	IC Socket	2460-7
042-029	IC Socket Pin	1938-4

048-027	Heat Sink No.27	
012-003	Midget Fuse Holder	TF-758
008-028	Midget Fuse	2A