

Congratulations and thank you for your purchase of the ADB2 Active Direct Box. The ADB2 is intended for sending unbalanced signals (up to +40 dB) to a mixing console or other professional input device. The unit has no transformer, so stray field pickup is nonexistent. The ADB2 is powered by standard microphone phantom power from 9 - 48 VDC and uses discrete low-noise differential drivers to make it very quiet. The unit has two 1/4" input jacks wired in parallel, a male XLR output jack, a ground lift switch, and a three-position attenuator switch.

### DESCRIPTION

**INPUTS:** Two 1/4" unbalanced jacks - wired together in parallel. For connection to line or instrument level signals.

**OUTPUT:** One male XLR jack for connection to mixing console or other input device carrying phantom power.

**ATTENUATOR SWITCH:** Decreases the input signal by the indicated amount. At 0 dB the signal is not attenuated, at the 20 and 40 dB settings, the signal is dropped by that amount.

**GROUND LIFT:** Removes the ground connection of the 1/4" and XLR jacks from the chassis ground.

**ACTIVE LED:** Indicates the unit is receiving phantom power.

### INSTALLATION

In order for the ADB2 to function it must be connected to a microphone phantom power source with a balanced XLR cord. The input may be anything from a speaker source such as a music amplifier, VCR or projector, to an instrument such as a guitar or High-impedance microphone. Care should be taken to overdrive the ADB2 or there will be a distorted sound from the unit. Use the lowest attenuator setting that gives distortion free sound. The ground lift switch should be in the position that yields the lowest noise.

### WARRANTY

For information on the Rolls One Year Limited Warranty, and to register this product, visit our website at [www.rolls.com](http://www.rolls.com)

### ADB2 Active Direct Box

- Uses standard 9 - 48 volt phantom power for supply
- Ground Lift for "hum" reduction
- Attenuator switch for connection to line level or speaker level signals

The ADB2 is an active direct box for converting a high impedance signal such as a direct out from a bass amplifier, to a low impedance signal such as a snake input and a mixer's microphone input. The Ground Lift is provided to reduce possible ground hum or buzz.

ADB2 Active Direct Box



# ROLLS

Rolls Corporation  
Salt Lake City, UT  
3/01

# ROLLS

## ADB2 Active Direct Box

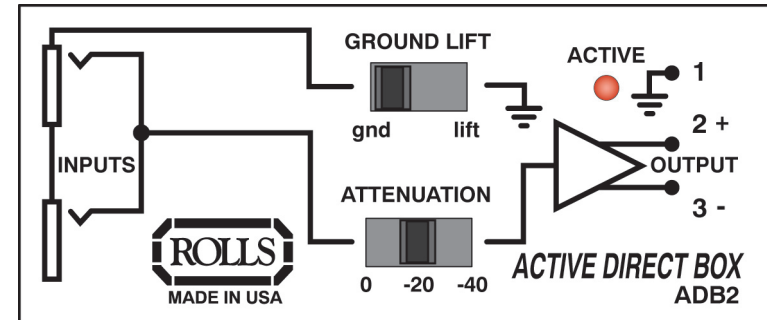

### SPECIFICATIONS

- Input Level: -10 to +40 dB unbalanced
- Output Level: -10 to +2 dB balanced XLR Male (pin 2 +)
- Bandwidth: 1 Hz to 50 kHz
- S/N Ratio: 100 dB
- Jacks: (2) 1/4" phone, (1) XLR male
- Controls: Attenuator switch, Ground Lift switch,
- Power: 9 - 48 VDC Phantom Powered
- Size: 2" x 3.5" x 5"

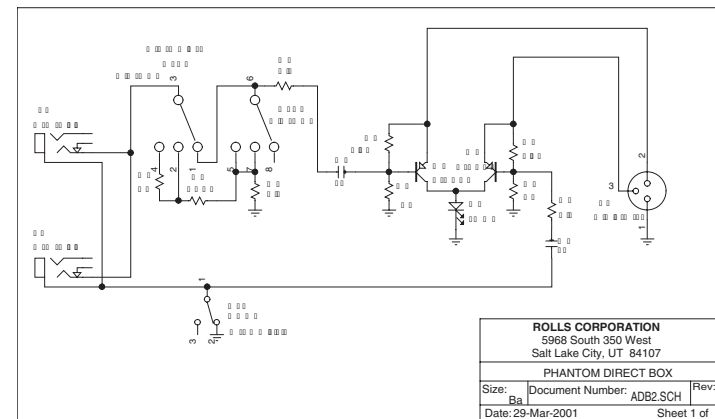

ROLLS CORPORATION 5968 South 350 West Salt Lake City, UT 84107			
PHANTOM DIRECT BOX			
Size: Ba	Document Number: ADB2.SCH	Rev: A	
Date: 29-Mar-2001	Sheet 1 of 1		