

SCAMP

S 02 Microphone Pre-Amp

- ★ TRANSFORMERLESS
- ★ LOW NOISE
- ★ 30dB PAD & PHASE REVERSE SWITCH
- ★ HIGH PASS FILTER
- ★ AUX. SEND, PRE or POST (switchable)
- ★ 600Ω LINE AMP DRIVE ON BOTH OUTPUTS
- ★ 70dB GAIN with OPTIMUM MODULATION INDICATOR
- ★ HI Z. INPUT ON FRONT PANEL JACK SOCKET

The SCAMP S 02 Microphone Pre-Amp was specifically designed and developed to broaden the scope of Scamp system applications. When incorporated into the SCAMP rack the S 02 Microphone Pre-Amp will interface between low level signals at source and the whole range of SCAMP signal processors.

Suitably equipped with the S 02 Microphone Pre-Amp the SCAMP system is now accessible to MUSICIANS, RADIO & TV PRODUCTION SUITES, THEATRES and other P.A. systems etc. This significant addition means that the SCAMP range can be used from any signal source right through to the final medium, be it tape, optical film, on-air broadcast or disc.

Front panel controls are provided to:

- vary input GAIN from 70dB to 30dB
- control master output level
- control AUX output level
- switch aux PRE or POST main output control and in/out switch
- switch in/out a 30dB pad for high level source signals
- switch in/out 12dB/oct Hi Pan filter
- channel mute switch and phase reversal

Additionally, on the circuit board, provision is included to select balanced (electronically) or unbalanced output and 48v phantom power (only in standard SCAMP rack configuration) send to mic. together with front panel mounted jack socket Hi Z input for no transformer Direct Injection.

To aid optimum utilization of the line a red l.e.d is incorporated to provide optimum modulation indication.



audio & design (recording) ltd.

84 OXFORD ROAD, READING RG1 7LJ, ENGLAND

S 02 Mic Pre-amp Technical Specification

INPUT	600 Ω
OUTPUT:	Less than 1 Ω
MAX. OUTPUT LEVEL:	+ 24dBm.
MAX. GAIN:	70dB.
INPUT PAD	30dB
FREQUENCY RESPONSE:	20Hz — 20kHz \pm 0.5dB
DISTORTION:	Less than 0.05% THD
NOISE:	-125dBm Ref. 70dB gain, 300 Ω source 20Hz — 20kHz bandwidth
COMMON MODE REJECTION:	Better than -90dB.
HIGH PASS FILTER:	12dB/octave -3dB 160Hz

ADR have a policy of constant improvement and consequently reserve the right to change or improve any of their specifications.

INSTRUCTION MANUAL FOR :-

S 02

MICROPHONE AMPLIFIER



audio & design recording

a FREE download from the archives of AnalogRules.com

N O T E

The Peak LED indicator is to indicate optimum modulation.

It operates at +11dBm which still leaves generous headroom level. Under normal operating conditions the indicator should light on peaks. If it is continuously on this will indicate a warning that modulation level could be approaching clipping.

1 INTRODUCTION
2 OPERATIONAL SECTION
2.1 Controls

SO2 MICROPHONE PRE-AMP

OPERATIONAL SECTION
2.1 Controls
2.2 Electrical Specifications
2.3 Connections
2.4 Procedure
2.5 General Notes
2.6 Servicing
2.7 Troubleshooting
2.8 Fault Repair
2.9 Factory Service
2.10
2.11
2.12

CONTENTS

- 1 INTRODUCTION

- 2 OPERATIONAL SECTION
 - 2.1 Controls
 - 2.2 Establishment in the Channel

- 3 TECHNICAL SECTION
 - 3.1 Technical Specification
 - 3.2 Module Connections
 - 3.3 Set Up Procedure
 - 3.3.1 Common Mode Rejection
 - 3.4 Routine Servicing
 - 3.4.1 Preventative Maintenance
 - 3.4.2 Fault Repair Maintenance
 - 3.4.3 Factory Servicing
 - 3.5 Circuit Diagrams
 - 3.5.1 General Arrangement
 - 3.5.2 Schematic
 - 3.5.3 Circuit 1 of 4
 - 3.5.4 Circuit 2 of 4
 - 3.5.5 Circuit 3 of 4
 - 3.5.6 Circuit 4 of 4

- 4 WARRANTY

1 INTRODUCTION

The S02 Microphone Pre-amp has been specifically designed and developed to broaden the scope of the SCAMP system and when incorporated into the SCAMP rack the S02 Mic Pre-amp will interface between low level, source signals and the whole range of SCAMP signal processors. This significant addition means that the whole SCAMP range can be used from any signal source right through to the final medium.

The operating instructions in this manual are divided into two parts:
operational (orange) - aimed at the user, engineer etc.

technical (green) - aimed at the user's maintenance department.

Whereas it is not essential that all users are necessarily familiar with both parts, initial reading is recommended for overall understanding and appreciation.

Wherever possible, pictures are used to give a clear indication and explanation - any queries raised should be directed at your local distributor or, if more convenient, directly to Sales Administration at Audio & Design

We believe that the most can only be got out of your new investment by understanding it fully, with that aim -

HAPPY READING.

2 OPERATIONAL SECTION

2.1 Controls

CHANNEL OUTPUT

Output level control

UNITY/30dB PAD

30dB attenuator when operating line level signals

CHAN. MUTE/ON

On/off switch

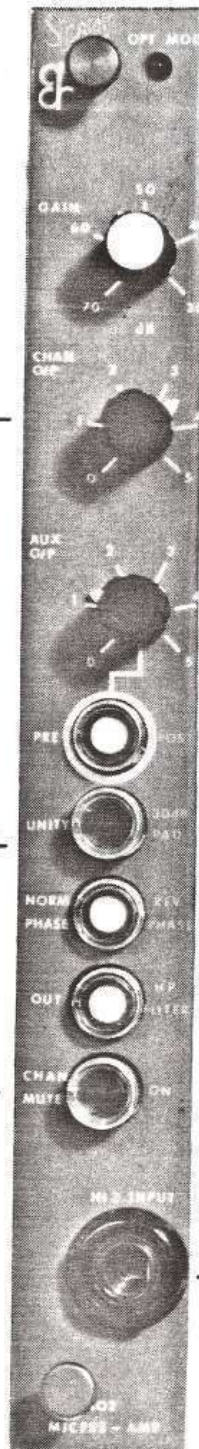

GAIN CONTROL

-70dB to 0 input gain

AUX OUTPUT

Switchable pre or post all other controls

NORM/REVERSE PHASE

OUT/HP FILTER

Reduces bass rumble mainly used for speech

HI Z INPUT

For direct injection into your SCAMP Rack.

2 OPERATIONAL SECTION

2.2 Establishment in the Channel

The Module is designed for incorporation into a SCAMP rack system. (if supplied without the SCAMP rack/power supply it will be necessary to provide a dual positive/negative supply of between 26-35v, dependent on the degree of smoothing.) The module carries its own regulation chips but care should be taken to ensure that proper regulation is being obtained. Supplied as a rack system the unit comes complete with power pack, it is necessary only to wire inputs and outputs to the solder pins on the 'mother' printed circuit board, as per connector data (see 3.2 Module Connections).

It is suggested that the rack be wired to a patch panel for easy routing, as required. There could be further advantage in arranging for insertion into the mixing console just before channel faders.

Selection of Balanced or Unbalanced Mode:

The System provides for electronic balancing of inputs and outputs (see 3.2 Module Connections). Check the line output switch on each module to ensure that the module is correctly adjusted for the mode of operation being used in the system. The effect of having the module in the 'unbalanced' position when the system is wired for balanced operation will be a 6dB increase in signal level at the output, and a corresponding increase in clip level to + 30dBm. Conversely there will be 6dB loss with the switch to 'Balanced' mode when the system is wired 'unbalanced'.

Set-up Procedure:

- i) With the 'System In/Out Switch' in 'Out' mode establish normal programme level through that channel. This should ideally be between 0dBm and + 16dBm, subject to a maximum of + 24dBm (clip level).

- ii) Set 'System In/Out Switch' to 'In'.

3 TECHNICAL SECTION

3.1 Technical Specification

INPUT	600 Ohms
OUTPUT:	Less than 1 Ohm
MAX.OUTPUT LEVEL:	+ 24dBm.
MAX.GAIN:	70dB
INPUT PAD:	30dB
FREQUENCY RESPONSE:	20Hz - 20kHz \pm 0.5dB
DISTORTION:	Less than 0.05% THD
NOISE:	-125dBm Ref.70dB gain, 300 source 20Hz - 20kHz bandwidth
COMMON MODE REJECTION:	Better than -70dB.
HIGH PASS FILTER:	12dB/octave -3dB 160Hz

3 TECHNICAL SECTION

3.2 Module Connections

- 1 +Ve in
- 2 -Ve in
- 3 0v
- 4 0v
- 5 Stereo link S 05
- 6 Stereo link S 06
- 7 + 48v Phantom Supply
- 8 0v Phantom Supply
- 9 Stereo link S 01
- 10
- 11
- 12
- 13
- 14
- 15
- 16
- 17
- 18
- 19 Output + phase
- 20 Output - phase
- 21 Chassis earth
- 22 Aux output
- 23
- 24 Chassis earth
- 25 Input + phase
- 26 Input - phase
- 27 Chassis earth
- 28
- 29
- 30
- 31
- 32
- 33
- 34
- 35
- 36
- 37
- 38
- 39
- 40
- 41
- 42
- 43
- 44
- 45

3 TECHNICAL SECTION

3.3 Set Up Procedure

3.3.1. Common Mode Rejection.

a) Set Front Panel Controls.

Gain 70

Chan

Aux o/p Max.

- b) Feed in -10dBm at 1KHZ on Pin 25 connect Pin 26 to GND
- c) Connect A.C.millivolt meter via test probe to TP1.
Level at TP1 should be $+20\text{dBm} \pm 0.5\text{db}$.
- d) Switch in 30dB Pad. Output should now be $-10\text{dBm} \pm 0.5\text{dB}$.
- e) Press Phase Rev switch O/P should not change.
- f) Connect phase and inverted phase I/Ps together (Pins 25 and 26).
- g) Set all presets to centre range.
- h) Ensure phantom supply is off.
- i) Adjust "Low Gain CMRR" preset for min o/p (better than -70dBm).
- j) Feed test probe directly into scope. (50mv/div . D.C. I/P)
- k) Turn 30dB pas to In and adjust scope for trace in centre of screen. Release 30dBs pad.
- l) Switch and adjust D.C.Bal preset trace to return scope trace to centre screen.

- m) Press pad switch and check trace does not move.
- n) For min o/p repeat as necessary.
- o) Set OSC to 60Hz @-10dBm.
- p) Return probe to millivolt meter.
- q) Set front panel controls. All out except chan mute switch.
- r) Adjust low frequency CMRR. Preset for min o/p (-70dBm.)
- s) Sweep to 10kHz o/p should not be less than -60dBm.
- t) Set front panel controls
 - Gain to 70 dB
 - Aux & Chan o/p to max.
 - Post SW out.
 - Filter SW out.
 - Pad SW out.
 - Phase SW out.
 - Chan mute on.
- u) Feed in -50dBm At 1khz Remove 200R I/P "R" output should be +20dBm Measure distortion to be better than 0.06%
- v) Connect ¼" jack to Hiz I/P feed in -50dBm.
O/P to read -10dBm.
- w) Increase I/P to -10dBm. Adjust gain pot.
- x) The opt mod indicator is just on. o/p should be =12dBm.
- y) Connect millivoltmeter to main o/p (Pins 19 & 20)
Feed in-50dBm to I/P (Pin 25) Ground Pin 26.
O/P should be +20 dBm. ± 0.5 dB.
- z) Sweep I/P freq from 20Hz to 25 kHz. Check o/p is flat ± 1.5 dB.

a FREE download from the archives of AnalogRules.com

- aa) Switch in H.P. filter check freq response. Should be -3dB At 180hz & 12dB /Octave below.
- ab) Switch out H.P. Filter.
- ac) Feed in 1khz -50dBm.
- ae) Turn gain pot to 30 position O/P should be -20dBm.
- af) Check operation on chan O/P pot.
- ag) Return to 70dB Gain position. Pad switch out short out I/P with 200R Resistor & Remove I/P signal. Noise level at O/P should read between -54dBm & -56dBm. (Band limiter 20Hz-20kHz)
- ah) Connect millivolt meter to Aux O/P (Pin 22) Check O/P is +20dBm.
- ai) Check operation of Aux O/P control.
- aj) Switch pre/post switch to post. Chan O/P control should alter O/P as well as Aux O/P control.

3 TECHNICAL SECTION

3.4 Routine Servicing.

3.4.1. Preventative Maintenance

The S02 Microphone Pre-amp is an all transistor device, thus the only maintenance necessary is to keep the unit clean. (Contaminants may lead to short circuits, high resistance or generally erratic operation.) The front panel is of brushed anodised aluminium hence any proprietary household detergent should do the job without fear of damage to nomenclature or plastic parts.

The switches are not all, in the interest of economy, hermetically sealed and hence may in time become erratic because of wear, corrosion or dirt deposits. They may be cleaned with commercial spray type contact cleaner but avoid letting excess cleaner contaminate other parts. Alignment instructions included in this manual are mainly for reference, it is recommended that only skilled, experienced and suitably equipped technicians attempt maintenance. (See also 3.4.3 Factory Servicing).

3.4.2 Fault Repair Maintenance.

The S02 is of highly advanced circuit design and technology. Where failure occurs it is advisable that repairs be performed by the factory, where specific skills and correct parts are available. Customer initiated repairs should only be attempted by competent technicians experienced in the area of linear IC's (where applicable) and skilled in the art of working on double-sided printed circuit boards. Additionally, a number of specialised parts are used which must be replaced by direct equivalents or performance degradation may occur.

3.4.3 Factory Servicing

Servicing is available at any time after expiry of the warranty (ref.4.0.), at reasonable charge for parts, labour and handling. However, before

returning the unit to us, it would be prudent to write or telephone, giving as much information about the fault as is to hand. Often the problem may be resolved in this fashion saving everybody time, effort and money whilst minimising your inconvenience.

THIRD ANGLE PROJECTION DO NOT SCALE THIS DRAWING. IF IN DOUBT ASK REMOVE ALL BURRS AND SHARP EDGES

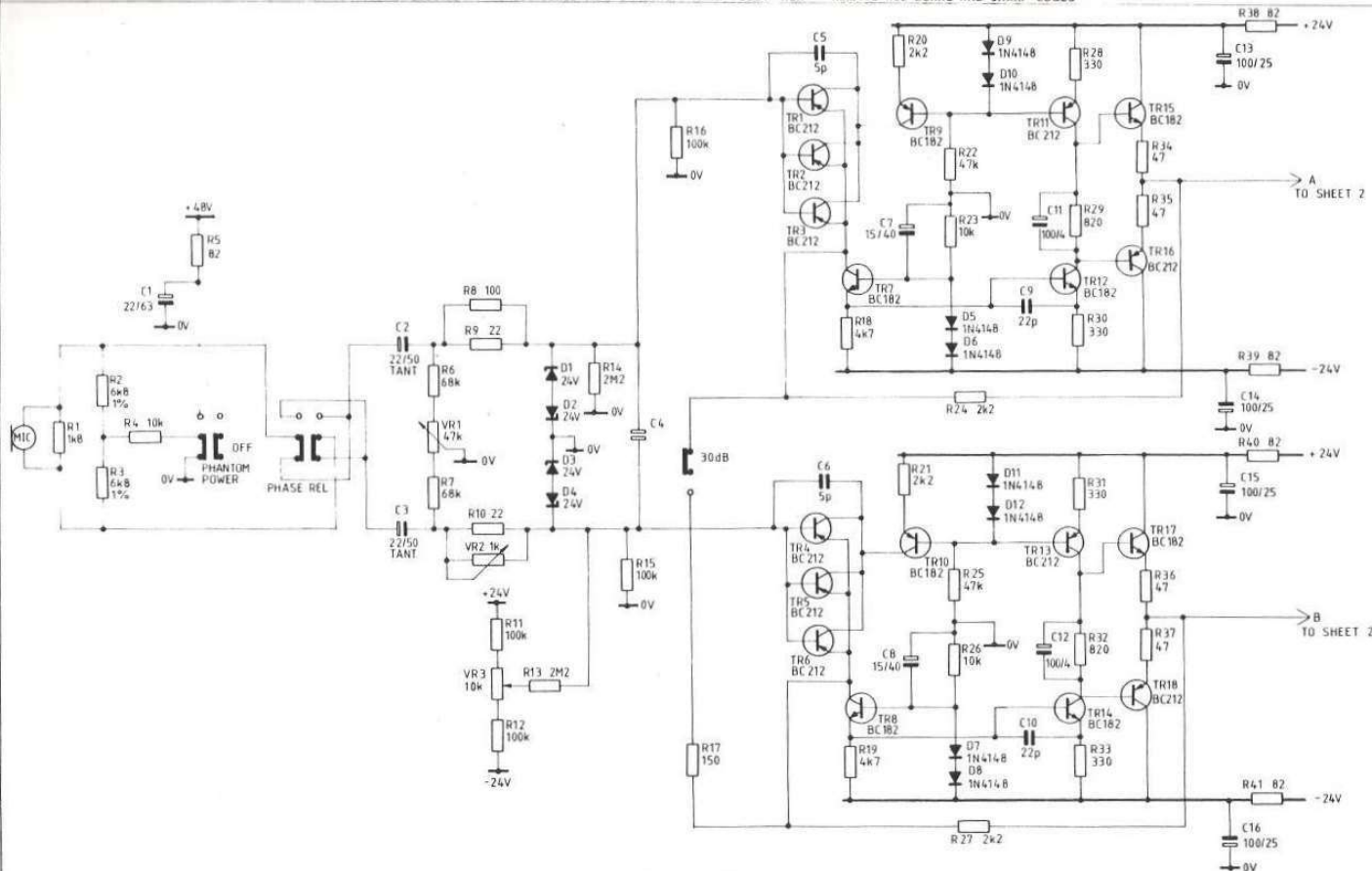

DRG No. S0200/3 SHT.1 OF 4 SHTS

**a FREE download
from the archives of
AnalogRules.com**

A	ALTERATION	USED ON
155		

MATERIAL	FINISH	SCALE	TITLE
			S02 MIC AMP
AUDIO & DESIGN RECORDING CRANBOURNE ASSOCIATES			CIRCUIT DIAGRAM A2
DATE SIG. ISS.			DRG No. S0200/3 SHT.1 OF SHT.4

SCAMP

S 02 Microphone Pre-Amp

- ★ TRANSFORMERLESS
- ★ LOW NOISE
- ★ 30dB PAD & PHASE REVERSE SWITCH
- ★ HIGH PASS FILTER
- ★ AUX. SEND, PRE or POST (switchable)
- ★ 600Ω LINE AMP DRIVE ON BOTH OUTPUTS
- ★ 70dB GAIN with OPTIMUM MODULATION INDICATOR
- ★ Hi Z. INPUT ON FRONT PANEL JACK SOCKET

The **SCAMP S 02 Microphone Pre-Amp** was specifically designed and developed to broaden the scope of Scamp system applications. When incorporated into the SCAMP rack the **S 02 Microphone Pre-Amp** will interface between low level signals at source and the whole range of SCAMP signal processors.

Suitably equipped with the **S 02 Microphone Pre-Amp** the SCAMP system is now accessible to **MUSICIANS, RADIO & TV PRODUCTION SUITES, THEATRES** and other P.A. systems etc. This significant addition means that the SCAMP range can be used from any signal source right through to the final medium, be it tape, optical film, on-air broadcast or disc.

Front panel controls are provided to:

- vary input *GAIN* from 70dB to 30dB
- control master output level
- control *AUX* output level
- switch aux *PRE* or *POST* main output control and in/out switch
- switch in/out a *30dB pad* for high level source signals
- switch in/out 12dB/oct *Hi Pan filter*
- *channel mute* switch and phase reversal

Additionally, on the circuit board, provision is included to select balanced (electronically) or unbalanced output and 48v phantom power (only in standard SCAMP rack configuration) send to mic. together with front panel mounted jack socket *Hi Z input* for no transformer Direct Injection.

To aid optimum utilization of the line a red l.e.d is incorporated to provide optimum modulation indication.



audio & design (recording) Ltd.

84 OXFORD ROAD, READING RG1 7LJ, ENGLAND

a FREE download from the archives of AnalogRules.com

S 02 Mic Pre-amp Technical Specification

INPUT	600 Ω
OUTPUT:	Less than 1 Ω
MAX. OUTPUT LEVEL:	+ 24dBm.
MAX. GAIN:	70dB.
INPUT PAD	30dB
FREQUENCY RESPONSE:	20Hz — 20kHz \pm 0.5dB
DISTORTION:	Less than 0.05% THD
NOISE:	-125dBm Ref. 70dB gain, 300 Ω source 20Hz — 20kHz bandwidth
COMMON MODE REJECTION:	Better than -90dB.
HIGH PASS FILTER:	12dB/octave -3dB 160Hz

ADR have a policy of constant improvement and consequently reserve the right to change or improve any of their specifications.