



SLX2 Wireless Transmitter Service Manual

25A1090

SLX2 WIRELESS HANDHELD TRANSMITTER

PRODUCT DESCRIPTION

The Shure Model SLX2 is a μ P (microprocessor) controlled frequency agile UHF handheld transmitter operating over the frequency range of 518 to 865 MHz (in eight different 24 MHz-wide frequency bands). The transmitter will operate for a minimum of 8 hours using two "AA" alkaline batteries. The User Interface includes "mode" and "set" buttons, and an LCD that displays battery status, group/channel, and transmitter/receiver frequency synchronization. The SLX2 has a plastic enclosure, and utilizes an internal antenna for optimum range and reliability. This product is intended for use in entry-level presentation, installed, and performance markets.

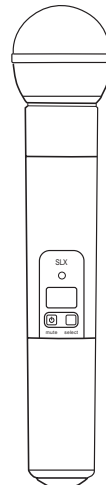

FEATURES

1. Frequency agile; microprocessor controlled. Model number extension determines frequency band of operation.
2. Minimum of 12 compatible systems per SKU in the U.S. Additionally, a minimum of 12 compatible systems in the top 50 U.S. markets across all three domestic SKU's (H5, J3, and L4).
3. Operating frequency programmable locally or from the receiver using a built-in IR link.
4. Designed for use with "AA" alkaline batteries (2 required). May also be used with rechargeable "AA" batteries. **Note:** battery condition indicator is calibrated for alkaline batteries and may not be accurate with rechargeable types. Electrical reverse battery protection is included.
5. Minimum battery life of 8 hours with new "AA" alkaline batteries.
6. Designed for use with SM58, BETA 58, SM86, and BETA 87A&C microphone heads. Compatible with "active load" or standard heads (active load circuitry to be incorporated in heads).
7. Tone key squelch.
8. Power/Mute and Select buttons with LCD display for frequency group/channel selection and control. LED backlight for easy reading of LCD display.
9. Bicolor, green/red LED for power "on" and low battery, mute and infrared link indications.
10. Rugged plastic construction.
11. Utilizes Shure Patented ARC (Audio Reference Companding) audio processing.

DETAILED DESCRIPTION

Features

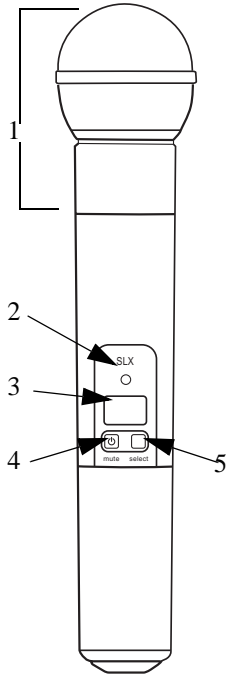

- 1 Interchangeable microphone head (SM58 pictured)
- 2 Power / Infrared (IR) / Mute indicator
 - Green: ready
 - Amber: mute on
 - Flashing red: IR transmission in process
 - Glowing red: battery power low
 - Pulsing red: battery dead (transmitter cannot be turned off until batteries are changed)
- 3 LCD screen
- 4 On-off / mute switch
 - Press and hold to turn on or off. Press and release to mute or unmute.
- 5 Select switch
- 6 IR port
 - Receives infrared beam to synchronize frequencies. **When using multiple systems, only one transmitter IR port should be exposed at a time.**

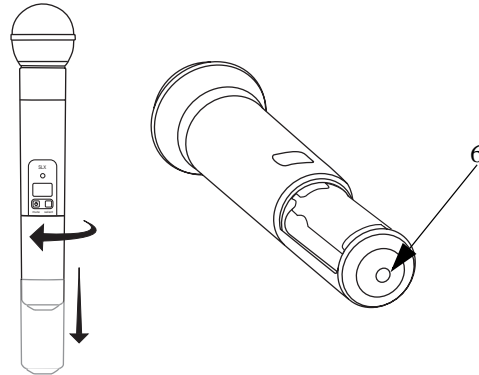

Adjusting Gain

Access the gain adjustment switch a by unscrewing the head of the microphone.

Two gain settings are available on the SLX2. Choose a setting appropriate for vocal volume and for the performing environment. Use the tip of a pen or a small screwdriver to move the switch.

- **0dB:** For quiet to normal vocal performance.
- **-10dB:** For loud vocal performance.

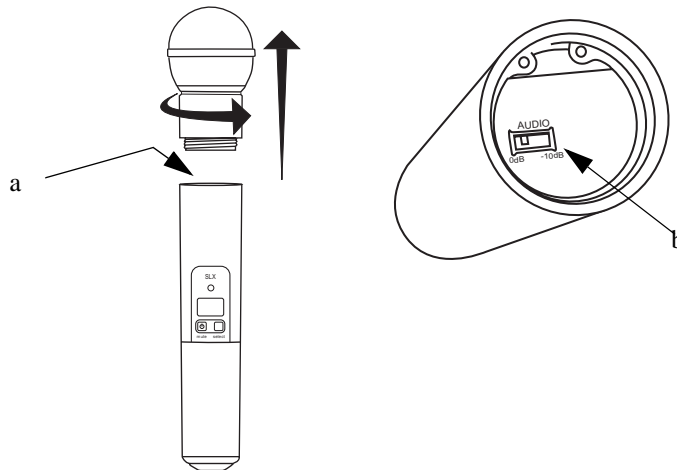

a



SLX2 Transmitter Programming

Manually Select a Group and/or Channel



1. Press and hold the **select** button until the GROUP and CHANNEL displays begin to alternate.
2. To change the group setting, release the **select** button while GROUP is displayed a. While GROUP is flashing, pressing **select** increases the group setting by one.
3. To change the channel setting, release the **select** button while CHANNEL is displayed b. While CHANNEL is flashing, pressing **select** increases the channel setting by one.

b



Lock or Unlock Transmitter Settings



Press the **mute/⏏** and **select** buttons simultaneously to lock or unlock the transmitter settings. When locked, the current settings cannot be changed manually. **Locking the transmitter does not disable infrared synchronization.**



Battery Status

Indicates charge remaining in transmitter batteries.



Master List Indicator

Indicates that a master list frequency is currently in use. No group or channel information is displayed.

Note: the transmitter cannot be used to change master list settings.



INCOMPATIBLE Frequency Warning

The **INCOMPATIBLE** warning indicates that the receiver and transmitter are transmitting on different frequency bands. Contact your Shure retailer for assistance.



AUDIO/RF BLOCK DIAGRAM

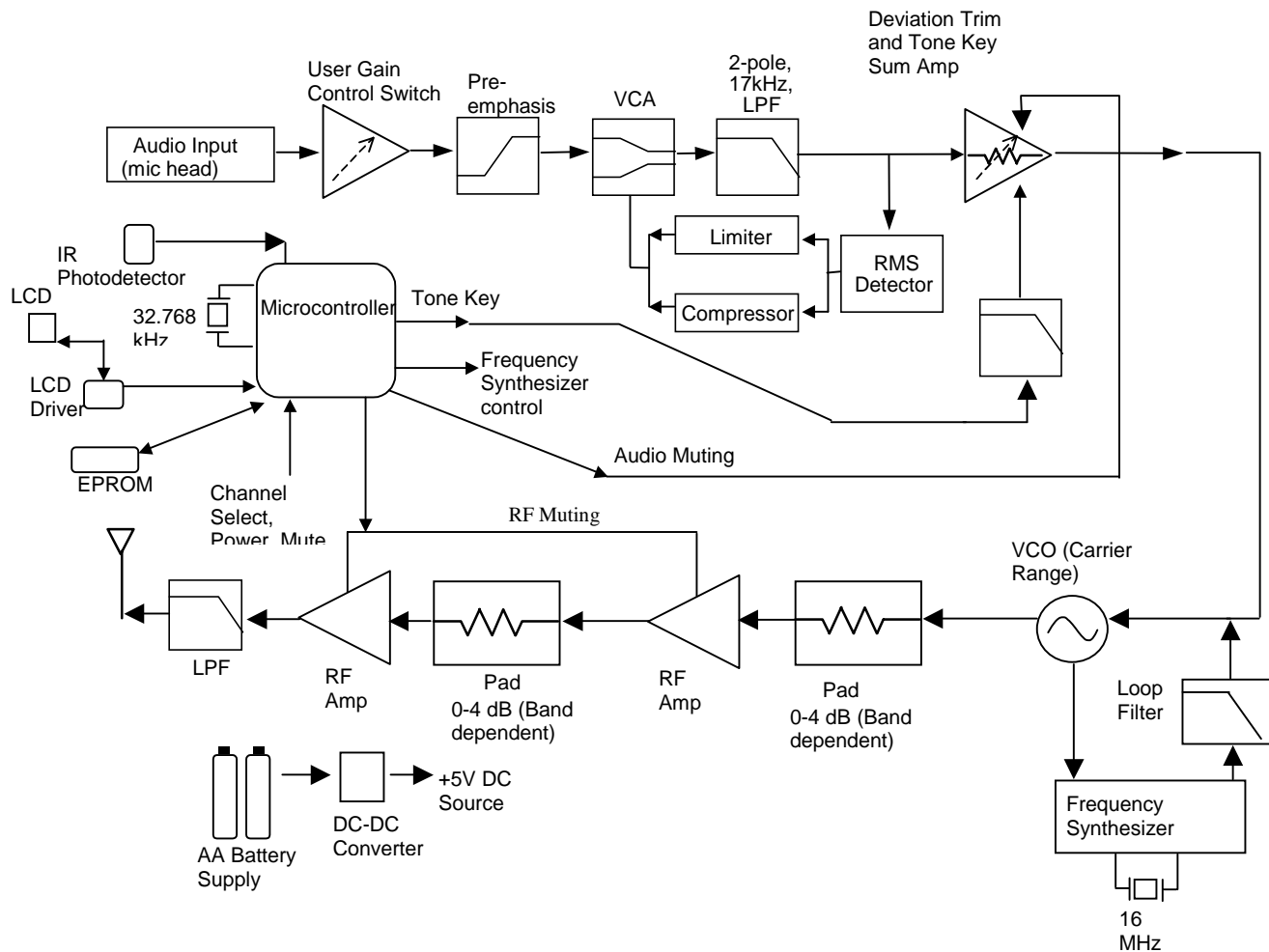

CIRCUIT DESCRIPTION

AUDIO CIRCUIT DESCRIPTION

AUDIO SECTION

Audio enters the transmitter board through pin 4 of the mic-jack board connector (CON100). Pin 2 of the connector provides 5 Vdc bias for the mic head. Pin 6 supplies the ground connection. The audio preamp (IC150-2) provides either 0 or 10 dB of gain (user switchable via SW100). Capacitor C140 couples the signal into a pre-emphasis network formed by R140, R141, and C141.

Next, the audio signal enters the patented Shure ARC™ processor. The main elements in this section are the VCA (IC100-5) and the RMS Detector (IC100-4). The VCA, or Voltage Controlled Amplifier, is a DC controlled amplifier. Following the VCA, the signal enters a 3-pole 17kHz low-pass filter stage (IC100-2) that protects the RMS detector from energy above the audio band. Next, the signal is coupled to the RMS detector (IC100-1), which converts it to a DC voltage. A +1 dB increase at the input to the detector produces a +6 mV increase at its output. The detector output is fed to the compression threshold stage (IC150-2). This stage provides the transition from uncompressed to compressed signal. At low levels, the audio is uncompressed because diode D169 is turned off. As the AC level increases, the output of IC150-2 decreases enough to turn the diode on. As D190 conducts, the compression ratio changes from 1:1 to 5:1. Once D190 is turned fully on, the audio compression ratio remains fixed at 5:1. An additional diode in the bias

network (D162) provides temperature compensation for changes in the V_{γ} , or "cut-in" voltage of D190. After the compression threshold stage, the DC control signal is amplified by a 40 dB fixed-gain stage (IC100-5). It is then sent to the VCA control voltage input (EC+).

Following the ARC™ processor section, the audio signal must pass through a muting network consisting of R199, R200, C205, and Q205. A trim pot (TR200) allows the audio deviation level to be set. Next, audio enters the tone key summing amp (IC150-4). Here, tone-key is added to the audio before passing to the RF section for transmission. The tone key signal is used in the receiver to provide audio output only when the tonekey signal is present with the transmitted signal; therefore, if the tone key or the transmitter is turned off, the receiver will be muted. The tone key squelch will eliminate receiver noise associated with loss of the carrier, which usually sounds like a "pop". The tone key signal is generated by a square wave from the mP (IC300). It is then filtered by active filter stage Q185 and attenuated by R188/R189 (under μ P control) before being fed to the summing amplifier. The combined audio/tone-key signal is then sent to the VCO through R504.

POWER SECTION

Two "AA" batteries supply power to the transmitter through FET Q410, which provides electrical reverse battery protection. Next, power enters switching boost converter IC400, which supplies regulated 5V power. To turn on the transmitter, SW325 shorts the base of Q480 to ground, enabling the converter and powering up the unit. The microprocessor keeps Q480 disabled until shutdown.

Power is turned off by a "shutdown" signal from the microprocessor, which can be initiated manually by the user (by holding down SW325 for 2.2 seconds) or automatically by the system (e.g., when the battery is too weak for proper operation). At this time, the microprocessor enables Q480 and shuts down the converter. When the unit is off, Q480 and its bias circuitry draw less than 30 μ A, so the effect on battery life is negligible. The converter and microprocessor are disabled.

LOW BATTERY SHUT DOWN:

A software battery shutdown routine allows the battery supply to run down to 2.05 V before shutdown, and will not turn the system back on until a voltage greater than 2.25 V is present. The hysteresis keeps the system in a controlled state when the batteries are low, and also helps prevent weak batteries from being used from the start.

RF CIRCUIT DESCRIPTION

RF SECTION

The system block diagram is shown above. The SLX2 uses a PLL system with direct carrier frequency modulation. Processed audio enters the VCO through a passive "reflection" network before being applied to the varactor diode (D500) through choke L503. The VCO is shielded to prevent external RF fields from affecting its operation, and to help control radiated emissions of its harmonics. Power for the VCO and PLL circuitry is supplied by the main 5 V regulator. Power and signal lines in the VCO area are heavily decoupled and bypassed to remove noise.

The VCO has a tuning bandwidth of more than 30 MHz on all bands, with a tuning voltage range of approximately 1 to 4 volts. The VCO employs separate stages for the oscillator (Q502) and buffer (Q501) to minimize phase noise and load pulling. The VCO output is isolated by capacitive and resistive dividers, before being applied to the frequency control pin of the PLL synthesizer (IC501) through C538. The synthesizer's internal circuitry divides the RF signal down as necessary to achieve a tuning precision of 25 kHz. The synthesizer circuit contains a quartz-controlled reference oscillator operating from a 16 MHz reference crystal (Y801) that is adjusted by means of trimmer CV501. The transmitter output frequency is user selectable in groups of compatible channels within each of the eight available bands. Frequency selection is made via microprocessor controller IC300, which interfaces with the user by means of the Group and Channel switches, SW324 and SW325. The output of the synthesizer is a series of pulses that are integrated by a passive loop filter consisting of C532, R514, C533, R513, and C531 to produce the control voltage signal.

The VCO output is coupled to the RF buffer stage (Q600) by a matching network consisting of R602, C614, and L610. R600 and R603 provide base bias for the transistor, while R605 sets its operating current. RF choke L600 provides power and decoupling for the stage, in conjunction

with C600 - C604. The collector of Q600 feeds the power amplifier stage via an impedance matching network consisting of L602, C611, and C618.

The bias voltage for the RF power amplifier (Q601) is supplied by R601 and R604. Its operating current is controlled via emitter resistor R606. RF choke L601 provides power and decoupling for the stage, in conjunction with C605-C609. For Japanese systems only, the output power is trimmed via TR640. L603, C612, and L604 provide the output impedance matching into the low pass filter, which consists of L604, L605, L606, C615, C616, and C617. The low pass filter output couples to the battery antenna via C641 and L607. Connector CON640 and C613 are only used for Japanese (JB) units. Coupling capacitor C610 is used to ensure that both batteries are driven equally.

The transmitter is capable of delivering up to +15.0 dBm to the antenna (depending on band and country). During transmitter power-up and frequency selection, the RF output is muted by bringing the base of Q631 low, which removes bias from Q630 and shuts down power to the RF stages. The RF output is also muted during the transmitter power-down sequence. This is done so that the carrier signal will not interfere with other transmissions when the loop becomes unlocked.

DIGITAL CIRCUIT DIAGRAM

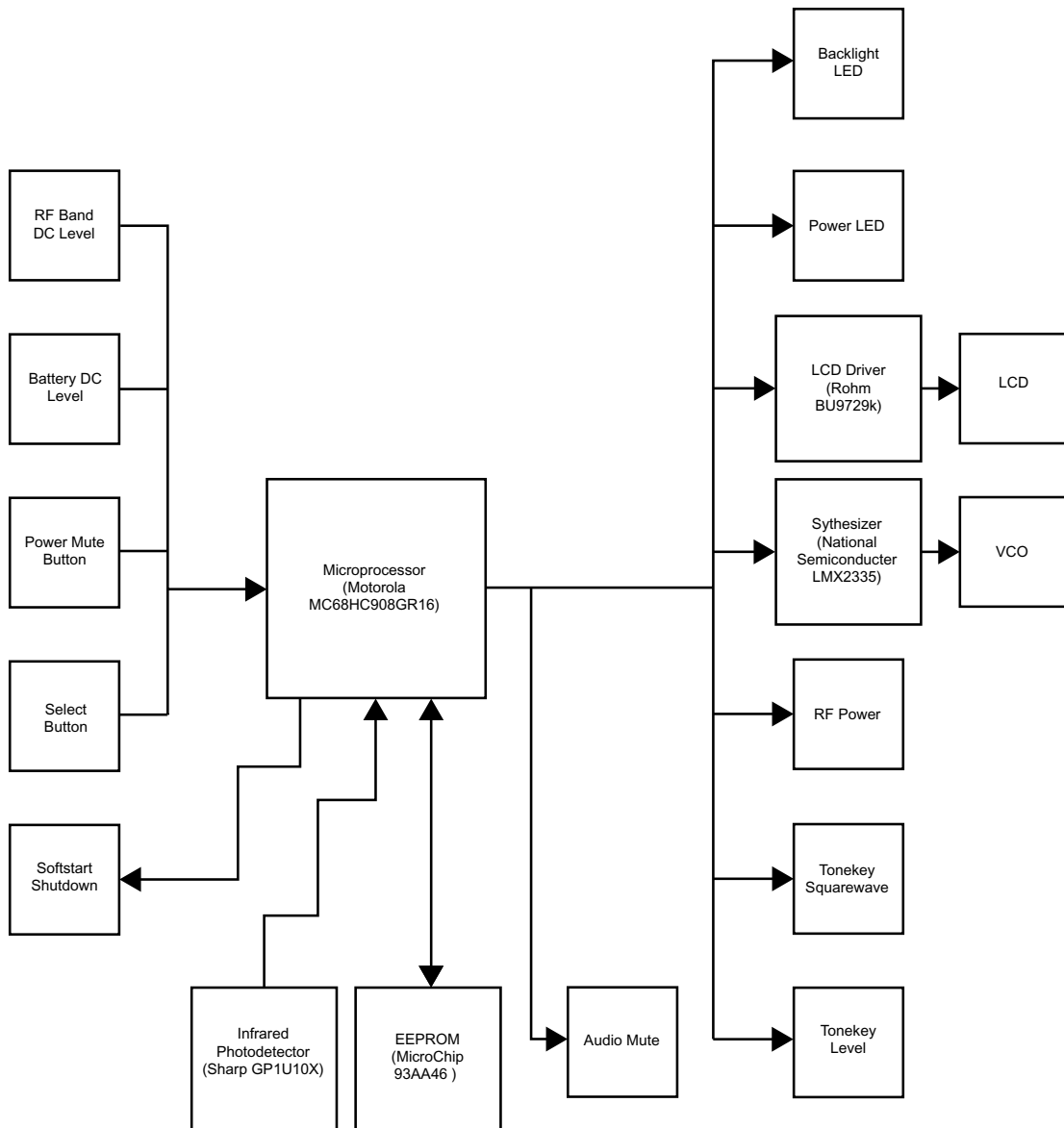

ACCESSING DIFFERENT MODES

ATE MODE

If TP_PB0 is held to TP_EGND, or logic level 0, at startup, the microcontroller will enter ATE Mode. To ensure proper operation, TP_PA0 and TP_PA1 should be held to TP_EGND at startup. In ATE Mode, each band has a three test frequencies that are controlled by the logic levels at test points TP_PA0 and TP_PA1.

Frequency	TP_PA0	TP_PA1
Low	0	0
Center	0	1
High	1	1

Test Frequencies (MHz)		H5	J3	JB	L4	P4	Q4	R5	S6
SLX2	Low	518.400	572.400	806.125	638.400	702.100	740.125	800.525	838.100
	Center	529.500	583.500	807.500	649.500	714.000	746.325	810.275	851.300
	High	541.800	595.800	809.750	661.800	725.900	751.875	819.800	864.800

RF BAND RESISTORS

Two resistors (R_A and R_B) are responsible to start the microcontroller in a RF band. They determine the voltage at test point TP_RFBAND.

This table shows R_A 's and R_B 's reference designators and how the voltages at the test points reflect the operating RF band.

SLX Reference Designators	
SLX2	
R_A	R_B
R319	R320

This figure depicts the voltage divider feeding the microprocessor analog to digital converter.

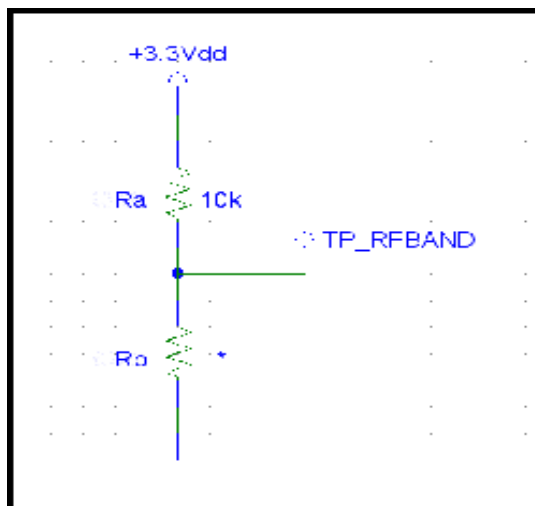



This table shows the variant resistor values and resulting voltages at TP_RFBAND for each band.

RF BAND	Rb	TP_RFBAND(+/- 0.10V)
H5	1.00k	0.30V
J3	2.99k	0.76V
L4	4.99k	1.10V
R5	7.50k	1.41V
S6	12.10k	1.81V
P4	18.2k	2.13V
Q4	30.1k	2.48V
JB	49.9k	2.75V

Note: Voltages are calculated with a 3.30V (+/- 0.10V) reference from the power supplies. If power section supports less than 3.30V, thresholds need to be adjusted.

µC DECISIONS BASED ON ANALOG VOLTAGES

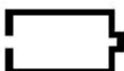
Continuous Operation Battery Thresholds				
BATTERY_A2D	RF Level	Display	Logic	Voltage (V)
Measured @ 3V block battery clips	- dBC		>=	2.25
	- dBC		<	2.25
	- dBC		<	2.14
	-8 dBC		<	2.05

Note: There is a dead battery lock voltage set at 2.30 Volts. If the transmitter is powered on with a voltage of less than 2.30 Volts, the system will lock, forcing the user to either recharge or replace the batteries. During the dead battery lock out, the battery gauge is empty and the red led flashes.

FUNCTIONAL TEST

REQUIRED TEST EQUIPMENT (OR APPROVED EQUIVALENT OR SUPERIOR MODELS):

Spectrum analyzer or power meter	HP8590L/Agilent E4403B/Agilent E4407B
Digital multimeter	Fluke 87
Audio Analyzer	HP 8903B
Frequency Counter	HP 53181/HP 5385A
Power Supply	Power Supply must be able to supply 3Vdc with an internal ammeter.
Shielded test lead	Shure PT1838F
BNC (Male) to BNC (Male) cable (1)	Shure PT1838A
UA820 Antenna	Frequency Dependent
Audio Test Head	PT1840
Brass Ring	PT1838Y

LISTENING TEST

Before completely disassembling the transmitter, operate it to determine whether it is functioning normally and try to duplicate the reported malfunction. Refer to pages 2 and 3 for operating instructions, troubleshooting, and specifications.

Review any customer complaint or request, and focus the listening test on any reported problem. The following, more extensive, functional tests require partial disassembly.

FUNCTIONAL TEST

Refer to the Disassembly section to partially disassemble the transmitter for the following functional tests.

TEST SETUP

1. Remove the PCB from the handle.
2. Set gain switch to "0" dB.
3. Connect the (+) terminal of the power supply through a milliammeter to the (+) battery terminal and the (-) power supply terminal to the (-) battery terminal.
4. Connect a DC Voltmeter across the power supply and set the power supply for 3Vdc.
5. Connect the audio analyzer to the microphone via the microphone test head (PT1840) as needed.

DISPLAY TEST

1. Power unit **ON**.
2. Verify that all display segments are displayed for approximately 2 seconds. This includes a full battery indication and "1818" displayed for group and channel.

REVERSE BATTERY PROTECTION TEST

1. Adjust power supply to -3.0 ± 0.1 V dc.
2. The current should be less than 0.5 mA.

VOLTAGE REGULATION TEST

With power applied properly, and the unit switched on, measure the DC voltages at the following test points. All test points are located on the top side of the PCB. Refer to the component diagram.

- TPBATT+ (Battery input) = 3 ± 0.2 Volts
- TP5V (Power Converter) = 5 ± 0.2 Volts
- TP3.3V (Power Converter) = 3.3 ± 0.2 Volts
- TPA1 (Audio Preamp) = 2.5 ± 0.2 Volts
- TPA3 (Tone Key Summing Amp (IC150 Pin 14)) = 2.5 ± 0.2 Volts
- TPVREF (IC100 Pin 5) = 2.5 ± 0.1 Volts

CURRENT CONSUMPTION TEST

1. With +3V applied to the battery terminals and the unit powered on.
2. Verify the current drain is 130 ± 15 mA.

FREQUENCY RESPONSE TEST

1. Set the audio generator as follows:
 - Frequency = 1 kHz
 - Amplitude = -20 dBu
 - Filters = 30 kHz LPF
2. With the audio analyzer, probe TPA2 (top side), it should read -3.4dBu \pm 0.5dB. **Record** this level using the Ratio button. This level will be used as your reference level for the following test.
3. Change the generator's frequency to 100Hz and measure the level at TPA2 to be -2.2dB \pm 0.2dB relative to the 1kHz reference level.
4. Change the generator's frequency to 10kHz and measure the level at TPA2 to be +2.3dB \pm 0.2dB relative to the 1kHz reference level.
5. Disengage the Ratio button.

DISTORTION TEST

1. Set the audio generator frequency to 1kHz with an amplitude of -20.0dBu.
2. Activate the 30kHz LPF on the audio generator.
3. Measure the total harmonic distortion and noise (THD+N) at TPA2 to be less than 0.7%.

RADIATED RF OUTPUT POWER AND FREQUENCY STABILITY TEST

1. Choose any group and channel free of interference. Using a spectrum analyzer with the appropriate-band UA820 antenna, measure the approximate near field radiated power as follows:
 - SPAN=100 MHz
 - REF LVL=10dBm
 - FREQUENCY=(Look at tables on pages 18 thru 23)
2. Extend the UA820 away from the analyzer into the horizontal plane (straight out). Align the SLX2 antenna parallel to the UA820 as close as possible. Move the unit along the UA820 antenna until you find a maximum peak.
3. Do a peak search and measure the power to be at least 2 dBm for H5, J3, L4, and P4 bands and at least 0 dBm for Q4, R5, JB, and S6 bands.
4. Set SPAN to 200 KHz. Measure the frequency to be within +/- 3 kHz of the nominal frequency you are testing. (See frequency tables on pages 19 to 24).

tone key level test

1. Set Power Supply to 3.0VDC
2. Find transmitting carrier on the spectrum analyzer with a span of 200 kHz. Use the "Peak Search, Marker Delta, Next Peak" soft-keys on the analyzer.
3. Measure the 32.768 kHz tone key level to be -21 dBc \pm 1.5 dB.
4. Set Power Supply to 2.1 V (1 segment on LCD battery icon).
5. Measure the 32.768 kHz tone key level to be -14 dBc \pm 1.5 dB.

OCCUPIED BANDWIDTH TEST (JB model only)

1. Set transmitter gain to maximum.
2. Set up the HP-8591E spectrum analyzer to measure Occupied Bandwidth with the following settings:
 - Percentage Power = 99.5%
 - Channel Spacing = 250 kHz
 - Bandwidth = 110 kHz
3. Connect the audio generator to TQG connector CON90. Use a 1 kHz tone with a level that gives -23.47 dBu (52mV) at TPA3.
4. Increase the audio level by 36dB.
5. Measure Occupied Bandwidth to be less than 110 kHz.

ADJACENT CHANNEL POWER TEST (JB model only)

1. Set the spectrum analyzer, and audio input level to the same settings as stated in "Radiated RF Output Power and Frequency Stability" and "Distortion Test".
2. Measure Extended Adjacent Channel Power to be less than -60 dB.

IF ALL TEST PASSED, THIS MEANS THE UNIT IS PROPERLY FUNCTIONING, AND NO ALIGNMENT IS REQUIRED.

ASSEMBLY AND DISASSEMBLY

!CAUTION!
Observe precautions when handling this static-sensitive device.

EXPLODED VIEW

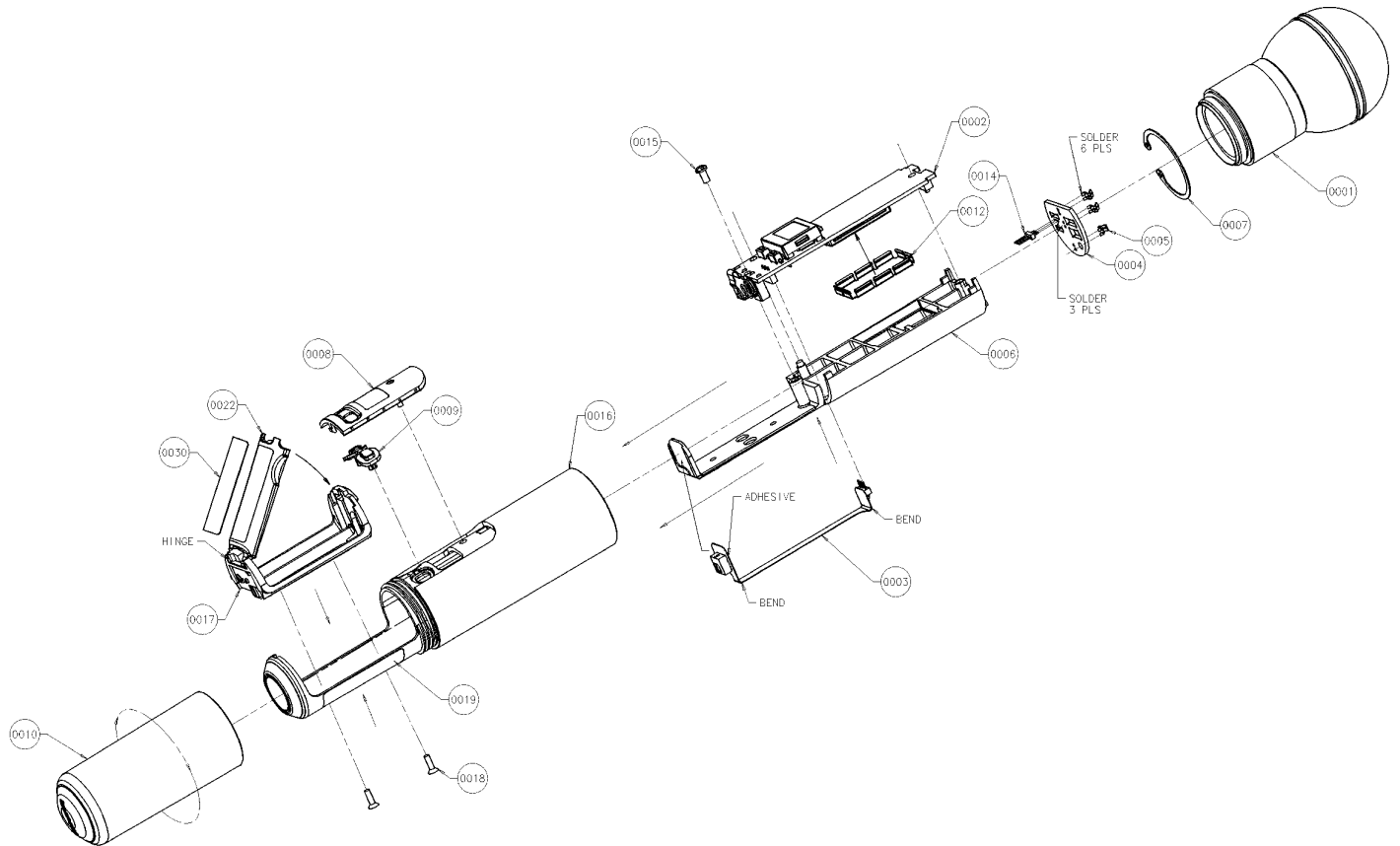

I.D. #	Description	Part Number
0001	Cartridge	
0002	Tuned PCB assembly	200--082
0003	PCB assembly, IR	190A098-01
0004	PCB, head board	190-057-03-34
0005	Contact	53F2039A
0006	Frame, internal	65B8467
0007	Retaining ring	30A1314
0008	bezel, painted/printed	65A8475B
0009	Pushbutton actuator, silicone	66A8070
0010	Battery cup, painted	65BA8451
0012	Shield cover, steel, plated	53A8590A
0014	3 pin interconnect	170A74
0015	PCB Screw, hi-lo #4	30J1245
0016	Handle assembly	95A9047B
0017	Battery holder assembly	95B9048
0018	Battery holder, Machine screw, #2-56	30D443E
0019	Nameplate, frequency	39--8466
0022	Battery cover assembly	95A9068

SERVICE PROCEDURES

MEASUREMENT REFERENCE

NOTE: Audio levels in dBu are marked as dBm on the HP8903.

dB Conversion Chart

$$0\text{dBV} = 2.2\text{ dBu}$$

$$0\text{dBu} = 0\text{dBm assuming the load} = 600\text{ ohms}$$

Be aware that dBu is a measure of voltage and dBm is a measure of power. The HP8903, for example, should be labeled dBu instead of dBm since it is a voltage measurement. These two terms are often used interchangeably even though they have different meanings.

REQUIRED TEST EQUIPMENT (OR APPROVED EQUIVALENT OR SUPERIOR MODELS):

Spectrum analyzer or power meter	HP8591E/Agilent E4403B/Agilent E4407B
Digital multimeter	Fluke 87
Audio Analyzer	HP 8903B
RF Signal Generator	HP 8656B or HP E4400B
Frequency Counter	HP 53181/HP 5385A
Receiver	Matching SLX4 Receiver
50 ohm, RG-174 BNC to open (stripped) coaxial cable or "rocket launcher" tip (P/N 95A8278). For JB, Murata cable # MXGS83RK3000 may be used.	Shure PT 1824
Audio Test Head	Shure PT1840
Brass Ring	Shure PT1838Y
BNC (Male) to BNC (Male) Cable (2)	Shure PT1838A
DC Blocker	Shure PT1838W
XLR (Female) to Banana Plug Adapter	Shure PT1841
20 dB Attenuator	Shure PT1838T
Toray non-inductive tuning tool - BLUE	Shure PT1838K
Toray non-inductive tuning tool - PINK	Shure PT1838L

ALIGNMENT PROCEDURE

Alignment and Measurement Procedure

The alignment procedure is sequential and does not change unless specified. Use RG58 or other low loss 50 ohm cables for all RF connections. Type RG174 (thin) 50 ohm cables can be used for short (e.g. 6 inch) runs. Keep RF test cables as short as possible. Include the insertion loss of the cables and the connectors for all RF measurements. DC voltages are present at most RF test points. Use DC blocks to protect the test equipment, if necessary. All audio analyzer filters should be OFF unless otherwise specified.

VOLTAGE REGULATION CHECK

With power applied properly, and the unit switched on, measure the DC voltages at the following test points. All test points are located on the top side of the PCB. Refer to the component diagram.

Test Points	Voltages
TPBATT+ (Battery input)	3 ± 0.2 Volts
TP5V (Power Converter)	5 ± 0.2 Volts
TP3.3V (Power Converter)	3.3 ± 0.2 Volts
TPA1 (Audio Preamp)	2.5 ± 0.2 Volts
TPA3 (Tone Key Summing Amp, IC150 Pin 14))	2.5 ± 0.2 Volts
TPVREF (IC100 Pin 5)	2.5 ± 0.1 Volts

INITIAL SETUP

1. Proper adapters should be used to connect the test equipment.
2. Apply +3 V to the battery terminals with the proper polarity.
3. Set audio gain switch SW100 to "-10 dB".
4. Remove L641 to disengage the antenna (**ALL EXCEPT JB**).
5. Solder the center of a 50Ω unshielded test cable (PT1824) to the node between L606 and L641, and the shield to ground.
6. Connect the audio generator output to the Mic Test Head input of the transmitter as required.
7. Turn on the SLX2 by pressing and holding the POWER button, SW325.

Frequency Level	H5	J3	JB	L4	P4	Q4	R5	S6
LOW	GRP. 1 / CH. 1	GRP. 1 / CH. 1	GRP. 1 / CH. 5	GRP. 1 / CH. 1	GRP. 14 / CH. 1	GRP. 1 / CH. 1	GRP. 4 / CH. 1	GRP. 13 / CH. 1
MID	GRP. 4 / CH. 7	GRP. 4 / CH. 7	GRP. 1 / CH. 2	GRP. 4 / CH. 7	GRP. 14 / CH. 5	GRP. 1 / CH. 5	GRP. 4 / CH. 7	GRP. 14 / CH. 7
HIGH	GRP. 6 / CH. 12	GRP. 6 / CH. 12	GRP. 5 / CH. 4	GRP. 6 / CH. 12	GRP. 15 / CH. 10	GRP. 1 / CH. 8	GRP. 2 / CH. 11	GRP. 3 / CH. 13

RF TUNING

The removal of L641 (prevents antenna loading of output).

VCO Tuning:

1. Set transmitter to its LOW frequency as indicated in the table above.
2. With a DC meter probe TP_PLL_TV (top).
3. Tune CV500 to obtain 1.10-1.40 Vdc at TP_PLL_TV. For Q4 units, this voltage should read between 1.45-2.25 Vdc. For JB units, this voltage should read between 1.75-2.05 Vdc.
4. Set the transmitter to HIGH frequency.
5. Verify voltage at TP_PLL_TV is less than or equal to 4.3 V DC.

FREQUENCY ALIGNMENT:

1. Set the transmitter to MID frequency (see table on page 14).
2. Connect the 50 Ω cable to a frequency counter.
3. Adjust variable capacitor CV501 until the frequency counter measurement matches the appropriate frequency on the table below, ± 1 kHz. .

GROUP CODE	FREQUENCY RANGE
H5	529.500 Mhz ± 1 kHz
J3	583.500 Mhz ± 1 kHz
JB	807.500 Mhz ± 1 kHz
L4	649.500 Mhz ± 1 kHz
P4	714.000 Mhz ± 1 kHz
Q4	746.325 Mhz ± 1 kHz
R5	810.275 Mhz ± 1 kHz
S6	851.300 Mhz ± 1 kHz

RF OUTPUT POWER

The output power measurement ensures that the output signal is strong enough for sufficient range when the system is in use. The output power measurement also verifies that the output power is not above the specified maximum level, to ensure compliance with regulatory agencies' standards.

1. RF output power is only adjustable on and **JB** units. Use RG58 (PT 1824) or any other low loss 50 Ω cables for all RF connections.
2. Include the insertion loss of the cables and connectors in rf conductive power measurements.
3. Connect the RF output of the transmitter to a spectrum analyzer.
4. Set the spectrum analyzer center frequency to match the transmitter frequency.
5. Using a power meter or spectrum analyzer, verify the output power matches the range indicated in the table below. **JB** models can be adjusted at TR640.

GROUP	Pout RANGE
H5	14 dBm ± 2 dB
J3	14 dBm ± 2 dB
JB	7.0 - 10.8 dBm
L4	14 dBm ± 2 dB
P4	14 dBm ± 2 dB
Q4	10 dBm ± 2 dB
R5	13 dBm ± 2 dB
S6	10 dBm ± 2 dB

6. Remove the BNC to unterminated test cable (PT1824) and replace L641 to reconnect the antenna.

DEVIATION ADJUSTMENT

Deviation must be set to make sure the companding systems between the transmitter and receiver correctly track each other. The level coming out of the transmitter's audio compressor must match the level going into the receiver's audio expander. A fixed gain structure does not ensure exact match, primarily because of variations in voltage-controlled oscillators (VCO's).

USING A SLX4 RECEIVER

The following procedure requires a SLX4 receiver. It is recommended that a properly tuned receiver be used to perform the transmitter deviation adjustment.

RECEIVER SETUP

SLX4 RECEIVER		AUDIO ANALYZER		RF SIGNAL GENERATOR	
Output:	Unbalanced	Measurement:	AC level	INT:	FM
Gain:	Maximum	Filters:		FM RATE:	1kHz
Toke Key:	Disabled (R280)	Low-Pass (30 kHz):	ON	Amplitude:	-50 dBm
		High-Pass (400 Hz):	ON	Deviation:	33 kHz

1. The SLX2 transmitter should be powered OFF for this procedure.
2. Connect the rf signal generator to any of the antenna inputs on the receiver. *Make sure the dc block is on the rf signal generator.*
3. Set rf signal generator to the same frequency as the SLX2 transmitter.
4. Set rf signal generator modulation to 1 kHz and deviation to 33 kHz.
5. Set the amplitude of the rf signal generator to -50 dBm.
6. Disable tonekey by shorting the pads of R280 on the receiver.

DEVIATION REFERENCE LEVEL

1. Power **ON** the receiver.
2. Connect the unbalanced output of the SLX4 receiver to the audio analyzer input.
3. **Note** the voltage obtained. This is the **deviation reference voltage**.
4. Disconnect the rf signal generator from the SLX4.
5. Power **OFF** the receiver and remove the short on the R280 pads to enable tonekey.

RADIATED DEVIATION REFERENCE VOLTAGE

SLX2 TRANSMITTER		AUDIO ANALYZER	
Power:	+3 Vdc	Measurement:	AC level
Atenuation:	-10 dB	Output:	1 kHz
Channel:	See Table	Filters:	
Group:	See Table	Low-Pass (30 kHz):	ON
		High-Pass (400 Hz):	ON

1. Connect the audio analyzer output to the Mic Test Head input of the transmitter.
2. Power ON the receiver.
3. Apply +3V to the battery terminals on the SLX2 and power up the unit.
4. Set the audio analyzer frequency to 1kHz.
5. Adjust the audio analyzer amplitude level (typically = -6.5 dBu) to obtain -13 dBu \pm 0.1dB at TPA1. (This corresponds to -9 dBu \pm 2dB at the audio input (TPA0)).
6. Adjust TR160 to obtain -3 dBu \pm 0.15dB at TPA2.
7. Place the transmitter closer than 12 inches (36 cm) to the receiver.
8. Connect both antennas on the receiver.
9. Connect the unbalanced output of the receiver to the audio analyzer.
10. Adjust TR200 until the ac voltmeter connected to the receiver unbalanced output reads the same **deviation reference voltage** \pm 0.1dB, as measured above.
(TR200 adjusts the deviation for 33 kHz, 100% modulation.)

If successful in the alignment of the unit, assemble it back together as indicated on page 12. If not successful refer to our Bench Checks section on page28.

NOTES:

FREQUENCY TABLES

H5: 518.000 - 542.000 MHz

Preprogrammed frequencies in total: > 120						
	Group 1	Group 2	Group 3	Group 4	Group 5	Group 6
1	518.400	519.250	518.200	519.775	519.100	518.425
2	521.500	520.500	519.675	522.500	521.225	520.400
3	523.575	522.225	520.800	524.200	522.550	523.425
4	525.050	524.725	522.450	525.600	524.575	525.475
5	527.425	526.350	523.750	526.700	526.900	527.775
6	529.200	527.550	526.200	528.250	530.500	531.675
7	532.450	530.800	528.325	529.500	531.750	533.800
8	533.650	532.575	532.225	533.100	533.300	536.250
9	535.275	534.950	534.525	535.425	534.400	537.550
10	537.775	536.425	536.575	537.450	535.800	539.200
11	539.500	538.500	539.600	538.775	537.500	540.325
12	540.750	541.600	541.575	540.900	540.225	541.800
Explanation of group content	Full Range even distribution for each TV-CH (option 1)	Full Range even distribution for each TV-CH (option 2)	Full Range max. # of frequencies for CH-22 (option 1)	Full Range max. # of frequencies for CH-23 (option 1)	Full Range max. # of frequencies for CH-24 (option 1)	Full Range max. # of frequencies for CH-25 (option 1)

J3: 572.000 - 596.000 MHz

Preprogrammed frequencies in total: > 120						
	Group 1	Group 2	Group 3	Group 4	Group 5	Group 6
1	572.400	573.250	572.200	573.775	573.100	572.425
2	575.500	574.500	573.675	576.500	575.225	574.400
3	577.575	576.225	574.800	578.200	576.550	577.425
4	579.050	578.725	576.450	579.600	578.575	579.475
5	581.425	580.350	577.750	580.700	580.900	581.775
6	583.200	581.550	580.200	582.250	584.500	585.675
7	586.450	584.800	582.325	583.500	585.750	587.800
8	587.650	586.575	586.225	587.100	587.300	590.250
9	589.275	588.950	588.525	589.425	588.400	591.550
10	591.775	590.425	590.575	591.450	589.800	593.200
11	593.500	592.500	593.600	592.775	591.500	594.325
12	594.750	595.600	595.575	594.900	594.225	595.800
Explanation of group content	Full Range even distribution for each TV-CH (option 1)	Full Range even distribution for each TV-CH (option 2)	Full Range max. # of frequencies for CH-31 (option 1)	Full Range max. # of frequencies for CH-32 (option 1)	Full Range max. # of frequencies for CH-33 (option 1)	Full Range max. # of frequencies for CH-34 (option 1)

JB: 806.000 - 810.000 MHZ

Preprogrammed frequencies in total: 21						
	Group 1	Group 2	Group 3	Group 4	Group 5	Group 6
1	806.250	806.375	806.125	806.500	806.125	806.250
2	807.500	808.625	807.375	807.375	807.375	807.250
3	809.625	809.750	809.500	808.625	808.375	808.500
4				809.625	809.750	809.375
Explanation of group content	Full Range max. # of compatible frequencies (option 1)	Full Range max. # of compatible frequencies (option 2)	Full Range max. # of compatible frequencies (option 3)	Full Range max. # of compatible frequencies (option 4)	Full Range max. # of compatible frequencies (option 5)	Full Range max. # of compatible frequencies (option 6)

L4: 638.000 - 662.000 MHZ

Preprogrammed frequencies in total: > 120						
	Group 1	Group 2	Group 3	Group 4	Group 5	Group 6
1	638.400	639.250	638.200	639.775	639.100	638.425
2	641.500	640.500	639.675	642.500	641.225	640.400
3	643.575	642.225	640.800	644.200	642.550	643.425
4	645.050	644.725	642.450	645.600	644.575	645.475
5	647.425	646.350	643.750	646.700	646.900	647.775
6	649.200	647.550	646.200	648.250	650.500	651.675
7	652.450	650.800	648.325	649.500	651.750	653.800
8	653.650	652.575	652.225	653.100	653.300	656.250
9	655.275	654.950	654.525	655.425	654.400	657.550
10	657.775	656.425	656.575	657.450	655.800	659.200
11	659.500	658.500	659.600	658.775	657.500	660.325
12	660.750	661.600	661.575	660.900	660.225	661.800
Explanation of group content	Full Range even distribution for each TV-CH (option 1)	Full Range even distribution for each TV-CH (option 2)	Full Range max. # of frequencies for CH-42 (option 1)	Full Range max. # of frequencies for CH-43 (option 1)	Full Range max. # of frequencies for CH-44 (option 1)	Full Range max. # of frequencies for CH-45 (option 1)

P4: 702.000 - 726.000 MHZ

Preprogrammed frequencies in total: 148									
	12	12	12	10	10	9	9	10	11
	Group 1	Group 2	Group 3	Group 4	Group 5	Group 6	Group 7	Group 8	Group 9
1	702.200	703.750	703.650	702.750	703.750	702.100	704.775	702.300	703.000
2	704.200	705.975	705.650	704.500	705.750	704.025	706.225	704.975	706.025
3	707.200	707.200	708.650	705.750	708.250	705.500	710.500	706.775	708.000
4	709.425	708.850	710.875	708.250	711.750	708.500	712.025	709.100	710.300
5	711.000	710.950	712.450	711.250	714.500	710.100	714.225	710.300	712.225
6	713.675	712.425	715.125	712.500	715.750	712.025	716.900	712.225	716.000
7	715.575	714.325	717.025	715.250	718.750	713.500	718.500	714.775	717.100
8	717.050	717.000	718.500	718.750	721.250	717.300	720.775	716.700	719.000
9	719.150	718.575	720.600	721.250	722.500	725.300	725.300	724.000	720.225
10	720.800	720.800	722.250	723.250	724.250			725.900	722.775
11	722.025	723.800	723.475						724.700
12	724.250	725.800	725.700						
Explanation of group content	Full Range max. # of compatible frequencies (option 1)	Full Range max. # of compatible frequencies (option 2)	Full Range max. # of compatible frequencies (option 3)	France preferred: User Group A (option 1)	France preferred: User Group A (option 2)	France preferred: User Group B (option 1)	France preferred: User Group B (option 2)	France preferred: User Group C (option 1)	France preferred: User Group C (option 2)

P4: 702.000 - 726.000 MHZ CONTINUED

	6	6	5	10	8	10	8
	Group 10	Group 11	Group 12	Group 13	Group 14	Group 15	Group 16
1	702.200	710.200	718.200	702.550	702.100	702.700	702.500
2	703.300	711.300	719.300	705.600	704.700	704.700	705.500
3	704.700	712.700	720.700	707.500	710.300	709.450	707.000
4	705.800	713.800	721.800	709.000	712.400	711.500	712.200
5	707.675	715.675	723.675	711.500	714.000	714.500	714.100
6	708.775	716.775		715.100	716.500	716.550	716.400
7				717.000	719.400	719.900	719.500
8				720.000	721.300	722.000	722.200
9				723.500		724.700	
10				725.900		725.900	
11							
12							
Explanation of group content	Optimized TV channels: TV ch. 50 702-710 MHz	Optimized TV channels: TV ch. 51 710-718 MHz	Optimized TV channels: TV ch. 52 718-724 MHz	Compatible setup for use with PSM400-P3 (P4 > P3)	Compatible setup for use with PSM400-P3 (P4 = P3)	Compatible setup for use with PSM400-HF (P4 > HF)	Compatible setup for use with PSM400-HF (P4 = HF)

Q4: 740.000 - 752.000 MHZ

Preprogrammed frequencies in total: 36				
	Group 1	Group 2	Group 3	Group 4
1	740.125	740.125	740.125	740.125
2	741.500	741.950	741.225	740.800
3	743.375	743.500	742.925	741.825
4	744.600	745.675	744.325	743.075
5	746.325	747.400	745.425	745.125
6	748.500	748.625	746.875	746.575
7	750.050	750.500	748.925	747.675
8	751.875	751.875	750.175	749.075
9			751.200	750.775
10			751.875	751.875
Explanation of group content	Full Range max. # of compatible frequencies (option 1)	Full Range max. # of compatible frequencies (option 2)	Full Range max. # of compatible frequencies (option 3)	Full Range max. # of compatible frequencies (option 4)

R5: 800.000 - 820.000 MHZ

Preprogrammed frequencies in total: 113							
	11	11	11	9	8	9	9
	Group 1	Group 2	Group 3	Group 4	Group 5	Group 6	Group 7
1	801.250	801.225	800.950	800.525	801.475	800.600	800.650
2	804.825	804.800	802.950	801.925	803.025	802.050	803.125
3	806.975	806.950	804.325	803.650	805.800	804.275	804.450
4	808.800	808.775	806.425	804.850	806.950	805.750	806.150
5	810.325	810.300	808.050	807.400	809.125	806.850	807.250
6	811.550	811.525	809.275	808.525	810.575	808.550	808.725
7	813.175	813.150	810.800	810.275	811.725	809.875	810.950
8	815.275	815.250	812.625	811.550	813.800	812.350	812.400
9	816.650	816.625	814.775	813.775		813.450	813.500
10	818.650	818.625	818.350				
11	819.750	819.800	819.775				
Explanation of group content	Full Range max. # of comp. Frequencies & FIN / NOR / DEN (option 1)	Full Range max. # of comp. Frequencies & FIN / NOR / DEN (option 2)	Full Range max. # of comp. Frequencies & FIN / NOR / DEN (option 3)	Germany preferred: User Group 4 800-814 MHz (option 1)	Germany preferred: User Group 4 800-814 MHz (option 2)	Sweden preferred: 800-814 MHz (option 1)	Sweden preferred: 800-814 MHz (option 2)

R5: 800.000 - 820.000 MHZ CONTINUED

	7	7	3	8	6	8	6
	Group 8	Group 9	Group 10	Group 11	Group 12	Group 13	Group 14
1	806.000	806.025	801.400	800.900	801.200	803.850	806.150
2	807.100	807.425	808.300	802.100	803.800	807.000	811.650
3	808.500	808.525	816.400	806.200	805.900	809.700	814.400
4	809.600	810.400		809.300	807.000	811.050	816.500
5	811.475	811.500		814.100	809.200	813.900	817.450
6	812.575	812.900		816.100	811.700	816.500	819.300
7	813.975	814.000		817.200		817.600	
8				819.600		819.500	
Explanation of group content	Compatible setup for use with EUT-TL-TV (R5 > TL-TV)	Compatible setup for use with PSM400-MN (R5 > MN)	Compatible setup for use with PSM400-MN (R5 = MN)	Compatible setup for use with PSM200-R8 (R5 > R8)	Compatible setup for use with PSM200-R8 (R5 = R8)	Compatible setup for use with EUT-TL-TV (R5 > TL-TV)	Compatible setup for use with PSM400-MN (R5 > MN)

S6: 838.000–865.000 MHZ

Preprogrammed frequencies in total: 119								
	13	13	13	6	3	3	6	6
	Group 1	Group 2	Group 3	Group 4	Group 5	Group 6	Group 7	Group 8
1	838.200	838.150	838.550	854.200	855.475	855.075	854.750	854.750
2	841.450	839.375	839.775	855.300	857.425	857.775	855.850	855.850
3	843.275	841.300	841.700	856.700	860.600	860.725	857.250	857.250
4	846.225	842.475	842.875	857.800			858.350	858.350
5	847.350	846.400	846.800	859.675			860.225	860.225
6	850.125	848.025	848.425	860.775			861.325	861.325
7	852.575	850.025	850.425					
8	854.575	852.475	852.875					
9	856.200	855.250	855.650					
10	860.125	856.375	856.775					
11	861.300	859.325	859.725					
12	863.225	861.150	861.550					
13	864.450	864.400	864.800					
Explanation of group content	Full Range max. # of compatible frequencies (option 1)	Full Range max. # of compatible frequencies (option 2)	Full Range max. # of compatible frequencies (option 3)	BEL / TUR preferred: opt. TV ch.69 854-862 MHz	U.K. preferred: "CH69 Co-ordinated" SET 1	U.K. preferred: "CH69 Co-ordinated" SET 2 or SET 3	U.K. preferred: "Co-ordinated frequencies" INDOORS	U.K. preferred: "Co-ordinated frequencies" OUTDOORS (option 1)

S6: 838.000–865.000 MHZ CONTINUED

	6	2	10	13	9	7	9
	Group 9	Group 10	Group 11	Group 12	Group 13	Group 14	Group 15
1	854.425	863.200	838.200	838.900	838.100	838.700	838.400
2	855.525	864.500	839.900	842.600	841.100	842.800	840.600
3	857.400		841.000	845.900	842.700	844.800	842.100
4	858.500		842.375	847.500	847.000	846.300	844.700
5	859.900		844.400	848.600	849.200	847.400	846.600
6	861.000		846.100	850.100	850.400	849.200	848.100
7			847.350	852.100	852.500	851.300	850.700
8			849.400	853.300	854.100		851.850
9			851.800	855.100	855.300		853.700
10			853.200	857.210			
11				858.650			
12				859.800			
13				861.900			
Explanation of group content	U.K. preferred: "Co-ordinated frequencies" OUTDOORS (option 2)	European harmonized band: optimized for 863 - 865 MHz	Compatible setup for use with EUT-TW-TZ (S6 > TW-TZ)	Compatible setup for use with EUT-VR-VT (S6 > VR-VT)	Compatible setup for use with PSM400-KE (S6 > KE)	Compatible setup for use with PSM400-KE (S6 = KE)	Compatible setup for use with PSM200-S5 (S6 > S5)

AGENCY APPROVALS

Note: Consult Global Compliance for latest applicable standards

FCC	(H5, J3, L4) - Part 74
IC	(H5, J3, L4) - RSS-123
ETS	(H5, J3, L4, P4, Q4, R5, S6,) - EN 300 422 and EN 301 489
TELEC	(JB) - RCR STD-22

PRODUCT PERFORMANCE CHARACTERISTICS

SPECIFICATION	Value
Operating Frequency (H5)	518.100 to 541.900 MHz
Operating Frequency (J3)	572.100 to 595.900 MHz
Operating Frequency (L4)	638.100 to 661.900 MHz
Operating Frequency (P4)	702.100 to 725.900 MHz
Operating Frequency (Q4)	740.100 to 751.900 MHz
Operating Frequency (R5)	800.100 to 819.900 MHz
Operating Frequency (S6)	838.100 to 864.900 MHz
Operating Frequency (JB)	806.125 to 809.750 MHz
Number of User Selectable Channels	See frequency table
Type of Emission	120KF3E
Oscillator	PLL-controlled synthesizer
RF Conducted Power Output	Band Dependent (See Table 1)
Tonekey Signal	32.768kHz
Maximum FM Deviation	38 kHz
Dynamic Range	> 100 dB
Total Harmonic Distortion	< 0.7% (38 kHz deviation, 1 kHz)
Audio Adjustment Range	-10, 0, or +15 dB; user selectable
Operating Voltage	3V (2 x AA; alkaline or rechargeable)
Power Consumption	130mA \pm 15mA @ 3V
Battery Life	> 8 hrs (alkaline batteries)

JB MODEL (CHANGES FROM R5 MODEL)

Operating Frequency	806 to 810 MHz
Number of User Selectable Channels	16 (125 kHz Spacing)
Frequency Stability	\pm 10 ppm
Reference FM Deviation 1 kHz audio level	5 kHz -23.47 dBu (52 mV) at TPA0
Output Power	See Table 1

PRODUCT SPECIFICATIONS

MECHANICAL

Overall Dimensions

64 mm x 109 mm x 19 mm (2.50 x 4.30 x 0.75 in.)

Weight

73 grams (2.6 oz), without batteries

Housing

Molded ABS case and battery cover

GENERAL

Frequency Range and Transmitter Output Level

Band	Range	Transmitter output
H5	518–542 MHz	30 mW/15 dBm
J3	572–596 MHz	30 mW/15 dBm
L4	638–662 MHz	30 mW/15 dBm
P4	702–726 MHz	30 mW/15 dBm
R5	800–820 MHz	20 mW/13 dBm
S6	838–865 MHz	10 mW/10 dBm
JB	806–810 MHz	10 mW/10 dBm
Q4	740–752 MHz	10 mW/10 dBm

NOTE: This Radio apparatus may be capable of operating on some frequencies not authorized in your region. Please contact your national authority to obtain information on authorized frequencies for wireless microphone products in your region.

Operating Range Under Typical Conditions

100m (300 ft.)

Note: actual range depends on RF signal absorption, reflection, and interference

Audio Frequency Response (+/- 2 dB)

Minimum: 45 Hz

Maximum: 15 kHz

Total Harmonic Distortion (ref. +/- 38 kHz deviation, 1 kHz tone)

0.5%, typical

Signal-to-Noise Ratio

>100 dB A-weighted

Operating Temperature Range

-18°C (0°F) to +50°C (+122°F)

Note: battery characteristics may limit this range

Transmitter Audio Polarity

Positive pressure on microphone diaphragm (or positive voltage applied to tip of WA302 phone plug) produces positive voltage on pin 2 (with respect to pin 3 of low impedance output) and the tip of the high impedance 1/4-inch output.

Gain Adjustment Range

25 dB

Audio Input Level

-5 dBV maximum at mic gain position

+10 dBV maximum at 0 dB gain position

+20 dBV maximum at -10 dB gain position

Input Impedance

1 MΩ

RF Transmitter Output

30 mW maximum (dependent on applicable country regulations)

Dimensions

254 mm H x 51 mm dia. (10x2 in) including SM58 cartridge

Weight

375.6 grams (13.25 oz) without batteries

Housing

Molded ABS handle and battery cup

Power Requirements

2 "AA" size alkaline or rechargeable batteries

Battery Life

>8 hours (alkaline)

ENVIRONMENTAL

Temperature Storage

7 days at +165 F (+74 F) degrees, unpackaged.

7 days at -20 F (-29 C) degrees, packaged.

After each 7-day storage period, units must be allowed to stabilize for 24 hours before testing. Units must operate per Section V.

Temperature Cycling

5 cycles from -20 F (-29 C) degrees to +165 F (+74 C) degrees. Allow 24 hours for stabilization before testing. Units must operate per Section V specifications mechanically and electrically.

Operational Temperature

Operate units as described in Section V at +0 F (-18 C) and +135 F (+57.9 C) degrees. Allow three hours for stabilization of each temperature before testing. Units must operate per Section V specifications.

Steady State Humidity

Perform a 10 day test at 90% RH at room temperature. Evaluate units for visual and mechanical defects after 1, 3, 5, 7, and 10 days. At the end of the 10-day period allow the units to recover for 24 hours. Units must pass Section V specifications.

Operational Humidity

Operate units as described in Section V at 90% RH at room temperature.

Allow two days for stabilization.

Moisture Resistance

Perform a 10-day test at 90% to 98% RH with temperature cycled between +14 F (-10 C) and +150 F (+65 C) degrees. Allow the units to recover for 24 hours. Product must meet Section V specifications.

Mechanical Shock

Handheld Drop Test: Drop product from a height of 6' onto a hardwood floor for a total of 10 drops. The unit must pass Section V specifications.

Stand Drop Test: Place product on a stand with the appropriate size swivel adapter. Drop unit from a height of 5' onto a hardwood floor for total of 10 drops. The product must meet Section V specifications.

Electrostatic Discharge

Product will be subjected up to a ± 15 kV air discharge and ± 4 kV contact discharge. Units must operate per Section V specifications.

TROUBLESHOOTING

Servicing will be more efficient when the history of the unit is known and can be taken into account. The service strategy should be different when a unit fails on the production line than when it fails in the field, because if it fails on the line there is a possibility of incorrect or missing parts. If the unit has failed in the field, check for signs of tampering or hand soldering that could indicate that the customer has modified the unit or has attempted to repair it.

PRELIMINARY TESTS

1. Install two fresh "AA" batteries and turn the unit on. Verify normal display operation. Set the unit to the lowest frequency in the group.
2. Observe the radiated output on a spectrum analyzer by holding it near the analyzer's antenna. Measure the frequency and RF power output level and verify that they are within expected limits.
3. Speak into the microphone. Observe the modulation on the spectrum analyzer display and listen to the audio output on a matching SLX4 receiver tuned to the same channel; preferably the customer's unit, if this is a field return. Check for normal audio level. Listen for distortion, noise, or any unusual sounds.
4. Change the frequency to the highest frequency in the group. Repeat steps 2 and 3 above and verify that operation is normal.

RF FREQUENCY OR SIGNAL PRESENCE PROBLEMS

If there is no carrier present at the transmitter antenna port or measured RF power is unusually low, check the earlier stages to verify decent continuity of the signal path. An amplifier stage or filter may have a part placement error or other defect. Usually the first step is to visually examine the board for skewed / missing parts before going in with a probe. If there is no signal out of the VCO output then check the control voltage at TP_PLL_TV when the transmitter is set at the lowest channel in the group. If the voltage is not tunable into the 1.1-1.4 V window but can be tuned to a lower or higher voltage, this means the VCO might be built for the wrong band or has a wrong part.

Check the values of the caps C522, C523, C528, C525, C534, and inductor L505 one by one and try to tune into the window. (Note that these caps are Low-ESR series!) If the voltage at TP_PLL_TV is 0 V and does not respond to tuning CV500, the loop is unlocked.

Check Y500 for a 16 MHz oscillation by setting the analyzer to CENTER FREQ=16 MHz, REF. LEVEL=-40 dBm, SPAN=1 MHz. Hold the probe right above the crystal and look for a spike-like signal. If one is present, check the parts in the VCO, including parts other than the capacitors mentioned above to see if anything is not soldered correctly.

Check bias voltages on the transistors to verify that they are powered and biased correctly. If an oscillation exists at the output and is close to the nominal center frequency (within 100 kHz) but cannot be tuned to the +/- 3 kHz window via CV501, check the value of the caps C536 and C537.

Check that the trimmer CV501 is soldered correctly.

LOW RF OUTPUT POWER

If RF signal is present at the right frequency with low power, compare the RF power measurements with a known good board at various points moving from the antenna backwards towards the VCO. Look for signal discontinuities in the path (sudden large drop in measured power by more than a few dB).

Check the board visually for missing/skewed parts. Try to confine the problem to a specific circuit segment, and then check solder connections and part values or DC voltages for error. If the power out of the VCO is very low, check the bias voltages on the transistors and the values of L502, C551, C543, C530.

EXCESSIVE CURRENT DRAIN

Try isolating different sections of the transmitter, such as the RF, Audio, and Digital circuits. Look for reversed polarity capacitors, wrong resistor values, poorly soldered components, and shorted traces.

DEVIATION PROBLEMS

If TR200 can't be adjusted to obtain proper deviation, try to isolate the problem to the Audio or RF section. To check the RF section, set the transmitter frequency to the frequency listed in Table 1.2 in Section IV and verify that the tuning voltage of the VCO is correct. To check the audio section, apply -10dBu at 1kHz to TPA0. Set the gain to "0 dB". Check for audio with a scope at TPA1. The level should be approximately 0dBu. Next, check the audio level at TPA2 for -0.8dBu. Finally, check the level at pin 14 of IC150-4. If the level is correct, check the values of R504, R510, R511, and C513-C5126 in the VCO area. If there is no audio, or the level is wrong, the problem is in the audio section. Trace backwards through the audio stages until you find the problem.

MICROCONTROLLER TROUBLESHOOTING

This paragraph describes what digital signals need to be seen to have audio running through a SLX system. The first thing that needs to be checked is, if the microcontroller is running its software.

If you see numbers or only fragments of numbers on the display after the unit has powered up, the microcontroller is running fine. Fragments of numbers in the display point to an open LCD driver pin or an intermittent LCD panel connection.

To test the microcontroller for normal operation, please test the following pins and conditions.

Microcontroller Pin Number	Net Name	Condition
1 to gnd	~RST	3.3V
4 to gnd	~IRQ	3.3V
Across 10 and 9	VDD and VSS	3.3V
Across 20 and 21	VDDAD and VSSAD	3.1V
Across 28 and 29	VDDA and VSSA	3.3V
31 to gnd	OSC2	Square Wave f0=32768Hz

The turn on procedure of the SLX transmitters includes several stages:

T = 0.000s: The power is turned on (soft switch). 5V and 3.3V are established approximately at the same time.

T = 0.480s: 32.768KHz crystal oscillates in a stable manner (~300ms) and internal reset cycle (~180ms) is over. From now software gets executed.

T = 0.???s: Microcontroller pin 5 (RF_VCC_OFF) goes from 5V to 0V. Synthesizer is powered on.

T = 0.???s: PLL data gets sent. You should see a signal similar to the graphic on an oscilloscope.

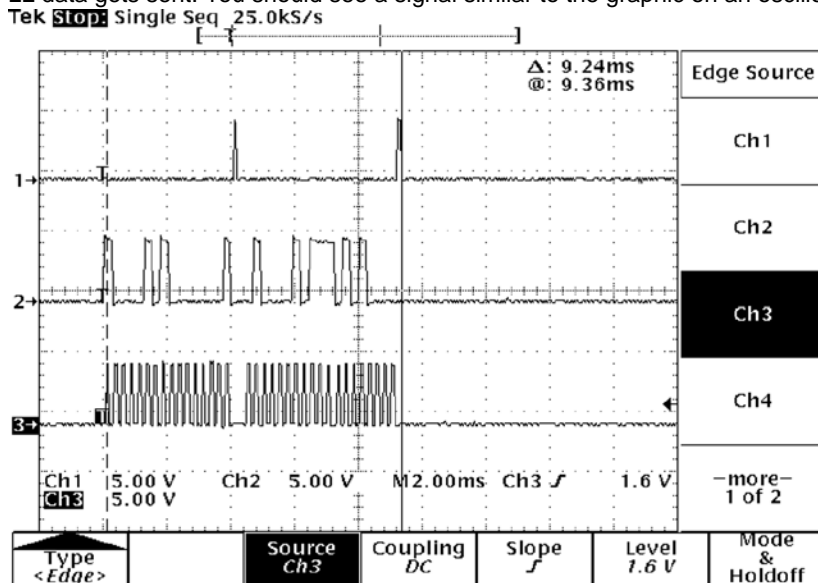

(1) = PLL_LE @ pin 34, (2) = PLL_DATA @ pin 35, (3) = PLL_CLOCK @ pin 36

T = 1.800s: Microcontroller pin 6 (RF_GND_ON) goes from 0V to 5V. RF carrier gets unmuted.

T = 2.000s: Tone-key is turned on. You will see a square wave ($V_{pp} = 5V$, $f_0=32768Hz$) at microcontroller pin 18 (TONEKEY_SQUARE). If these stages can be captured with the scope, the microcontroller did its part to let audio go through the system. If audio is still not being transmitted, please involve RF spectrum analyzer and oscilloscope to debug the RF and audio stage of the transmitter.

REPLACEMENT PARTS

PRODUCT CHANGES

PARTS DESIGNATIONS

The following comments apply to the parts list and the schematics:

Resistors: Unless otherwise noted, all resistors are surface-mount with 1/10 W rating and 1% tolerance.

Capacitors: Unless otherwise noted, non-polarized capacitors are surface-mount NPO dielectric types with a 100 V capacity and a 5% tolerance, and polarized capacitors are tantalum types.

SLX2 MODEL VARIATION

COUNTRY CODE	FREQUENCY RANGE	COUNTRY DESIGNATION	SLX2 RF-AUDIO PC BOARD NUMBER
H5	554-590 MHz	U.S.A. and CANADA	200H510304
J3	572-596 MHz	U.S.A. and CANADA	200J310304
L4	638-662 MHz	U.S.A. and CANADA	200L410304
P4	702-726 MHz	EUROPE / CHINA	200P410304
Q4	740-752 MHz	KOREA	200Q410304
R5	800-820 MHz	EUROPE	200R510304
S6	838-865 MHz	GREAT BRITAIN	200S610304
JB	806-810 MHz	JAPAN	200JB10304

SLX2 HARDWARE REPLACEMENT PARTS

Reference Designation	Description	Shure Part Number
A1	IR Assembly	190A10302
	IR Detector 40kHz	188A617
	3 Pin Male Connector Strip	170A76
A2	Handle Assembly	95A9047B
	Aluminum ID Ring	53A8594
	IR Bezel	65A8474
A3	Battery Cover Assembly	95A9068
	Foam Pad	36A814
A4	Battery Holder Assembly	95B9048
MP1	Headboard PCB	190-057-03-34
MP2	Copper Contacts	53F2039A
MP3	3 Pin Interconnect Strip	56E8074
MP4	Retaining Ring	30A1314
MP5	Internal Frame	65B8467

MP6	Bezel	65A8475B
MP7	Pushbutton Switch Actuator (Power/Mute/Select)	66A8070
MP8	Battery Cup	65BA8451
MP9	Frequency Nameplate	39_8466 Provide Frequency Code In The Space
MP10	PCB Screw	30J1245B
MP11	Battery Nest Screws	30D443E
MP12	RF Shield Cover	53A8590A
MP13	LCD Holder/Backlight	65A8452
MP14	LCD Bezel	53A8573B
MP15	LCD	95A8991
MP16	LCD Zebra Connector	80A8257
MP17	Compression Pad (For Positive Battery Contact)	38D189

SLX2 REPLACEMENT PARTS (TOP)

Reference Designation	Description	Shure Part Number
C100	Capacitor, Tantalum, SMD1206, 15uF, 10V, 10%	151AC156KA
C162	Capacitor, Tantalum, SMD1411, 10uF, 16V, 10%	151AD106KB
C531	Capacitor, Tantalum, SMD1206, 0.1uF, 35V, 10%	151AG104KA
C432, 548, 549	Capacitor, Tantalum, SMD1411, 100uF, 6V, 10%	151AB107KB
DS375	Chipped Green LED	184A77
DS420	Bicolor (Red/Green) LED	184A39
E408, 500	Bead, Ferrite, SMD 805, 600 OHM	162A12
IC1	L.C.D. Backlight Holder	65A8452
IC100	28 Pin QSOP Compander (THAT4320)	188A568
IC370	1K Microwire EEPROM (93AA46AT-I/OT)	188A577
IC350	Segment-Type, LED Driver	188A506
IC430	3.3V CMOS LDO Regulator (SP6213EC5)	188A590
Q185	Low Noise Transistor (MMBT5089L)	183A38
Q410	Transistor, Power, Mosfet (NSD355AN)	183A74
SW324, 325	Switch, Pushbutton, Momentary, SPST	155A21
Y331	Crystal, Quartz, SMD, 32.768 kHz	40A8010

SLX2 REPLACEMENT PARTS (BOTTOM)

Reference Designation	Description	Shure Part Number
CON100	3 Pin Socket Strip (Female) For headboard	170C15
CON301	3 Pin Socket Strip (Female) For IF cable	95A9054
CON600	Positive Battery Contact	53A8591
CON601	Negative Battery Contact	95A9064
CON640	Connector, COAX w/Switch (ONLY JB models)	170A36
CV500	Trim Cap., SMD, 0.65 - 2.5pF	152A04
CV501	Trim Cap., SMD, 3.0 - 15pF	152E05
D162, 190	Switching Dual Diode, SMD (MMBD2836L)	184A07
D400, 480	Common Anode Schottky Diode (BAT 54A)	184B69
D500	Variable Capacitance Diode	184A72
D600	Dual Schottky Diode (BAT 54S)	184A69
E100	Bead, Ferrite, SMD 805, 600 OHM	162A12
IC150	Quad Op. Amp., SO-14 (MC33179)	188A49
IC400	Sync Boost Converter (LTC3400ES6)	188A479
IC501	Low Power Dual Synthesizer (LMX2335LTM)	188B388

L404	Inductor, SMD 2518, 4.7nH	162A64
L501, 503	Inductor, SMD 603, 100nH	162A25
L600, 601	Inductor, SMD 603, 150nH	162AE56
L611	Inductor, SMD 603, 10nH	162N25
Q205	Transistor, TMOS, SOT-23 (2N7002L)	183A30
Q475	Transistor, Power, Mosfet (NSD355AN)	183A74
Q501, 502	Transistor, High Frequency (2SC5006)	183A66
Q600	Transistor, SOT-23 (AT-41533)	183A49
Q601	Transistor, Bipolar, Silicon (AT-41486)	183A44
Q630	Transistor, PNP, SOT-23 (MMBT2907L)	183A27
Q375, 480, 631	Transistor, Low Noise, SOT-23 (MMBT5089L)	183A38
SW324, 325	Switch, Pushbutton, Momentary, SPST	155A21
SW100	Switch, Slide, 2-Position	155A32
TR160, 200	Trim-pot., Line, 100K Ω	146E10
TR640	Trim-pot., Line, 470 Ω	146A10
Y500	Crystal, Quartz, SMD, 16MHz	140A26

MICROCONTROLLER (IC300) SELECTION

Country Code	Shure Part Number
H5	188A585A
J3	188B585A
L4	188C585A
P4	188D598A
Q4	188E585B
R5	188F585A
S6	188G585A
JB	188H585B

FREQUENCY DEPENDENT PARTS**

Frequency Code	H5	J3	L4	P4	Q4	R5	S6	JB
C506	150pF	68pF	68pF	68pF	68pF	68pF	68pF	68pF
C522	6.8pF	5.6pF	4.7pF	3.9pF	3.9pF	3.3pF	3.3pF	3.3pF
C523	3.3pF	3.9pF	2.7pF	2.2pF	3.9pF	2.2pF	2.2pF	2.2pF
C525	3.9pF	3.9pF	2.2pF	2.2pF	1.8pF	1.8pF	1.8pF	1.8pF
C528	3.3pF	1.5pF	2.2pF	1.0pF	2.7pF	1.5pF	1.0pF	1.5pF
C534	3.9pF	3.9pF	2.7pF	2.7pF	2.2pF	2.2pF	2.2pF	2.2pF
C543	12pF	10pF	4.7pF	4.7pF	6.8pF	6.8pF	6.8pF	6.8pF
C551	8.2pF	5.6pF	4.7pF	4.7pF	5.6pF	5.6pF	5.6pF	5.6pF
C603	120pF	68pF	68pF	68pF	68pF	68pF	68pF	68pF
C611	3.9pF	2.7pF	2.7pF	2.2pF	3.9pF	3.9pF	3.3pF	3.9pF
C612	10pF	6.8pF	6.8pF	6.8pF	10pF	10pF	5.6pF	10pF
C615	2.7pF	2.2pF	2.2pF	2.2pF	2.2pF	2.2pF	3.3pF	2.2pF
C616	10pF	12pF	12pF	12pF	12pF	12pF	10pF	12pF
C617	6.8pF	8.2pF	8.2pF	8.2pF	8.2pF	8.2pF	8.2pF	8.2pF
C618	12pF	10pF	5.6pF	3.9pF	6.8pF	6.8pF	4.7pF	6.8pF
C619	120pF	68pF	68pF	68pF	68pF	68pF	68pF	68pF
C651	8.2pF	6.8pF	4.7pF	2.2pF	5.6pF	5.6pF	5.6pF	5.6pF
C97	DNP	DNP	DNP	DNP	DNP	DNP	DNP	DNP
E301	600 Ω	DNP	DNP	DNP	DNP	DNP	DNP	DNP
E302	600 Ω	DNP	DNP	DNP	DNP	DNP	DNP	DNP
E303	600 Ω	DNP	DNP	DNP	DNP	DNP	DNP	DNP

E603	600Ω	600Ω	600Ω	600Ω	DNP	DNP	DNP	DNP
L301	DNP	220nH	220nH	220nH	180nH	180nH	180nH	180nH
L302	DNP	220nH	220nH	220nH	180nH	180nH	180nH	180nH
L303	DNP	220nH	220nH	220nH	180nH	180nH	180nH	180nH
L400	470nH	470nH	470nH	470nH	220nH	220nH	220nH	220nH
L401	470nH	470nH	470nH	470nH	220nH	220nH	220nH	220nH
L502	15nH	15nH	15nH	12nH	6.8nH	6.8nH	6.8nH	6.8nH
L505	5.4nH	5.4nH	3.85nH	3.85nH	2.55nH	2.55nH	2.55nH	2.55nH
L602	22nH	22nH	18nH	15nH	8.2nH	8.2nH	8.2nH	8.2nH
L603	DNP	DNP	DNP	DNP	180nH	180nH	180nH	180nH
L604	18nH	18nH	12nH	12nH	8.2nH	8.2nH	10nH	8.2nH
L605	15nH	12nH	8.2nH	8.2nH	6.8nH	6.8nH	6.8nH	6.8nH
L606	15nH	12nH	8.2nH	8.2nH	6.8nH	6.8nH	6.8nH	6.8nH
L607	15nH	8.2nH	12nH	DNP	8.2nH	8.2nH	12nH	8.2nH
L640	DNP	DNP	DNP	DNP	DNP	DNP	DNP	12nH
L641	6.8nH	8.2nH	10nH	1.2nH	12nH	12nH	12nH	DNP
R1	1K	DNP	DNP	DNP	DNP	DNP	DNP	DNP
R2	DNP	1K	DNP	DNP	DNP	DNP	DNP	DNP
R201	121K	150K	121K	121K	121K	121K	150K	150K
R3	DNP	DNP	1K	DNP	DNP	DNP	DNP	DNP
R320	1K	3.01K	4.99K	18.2K	30.1K	7.5K	12.1K	7.5K
R4	DNP	DNP	DNP	1K	DNP	DNP	DNP	DNP
R5	DNP	DNP	DNP	DNP	1K	DNP	DNP	DNP
R6	DNP	DNP	DNP	DNP	DNP	1K	DNP	DNP
R606	22.1Ω	22.1Ω	22.1Ω	22.1Ω	22.1Ω	22.1Ω	22.1Ω	49.9Ω
R607	DNP	DNP	DNP	0Ω	DNP	DNP	DNP	DNP
R612	499Ω	499Ω	499Ω	499Ω	221Ω	DNP	DNP	221Ω
R613	10Ω	10Ω	10Ω	10Ω	22.1Ω	0Ω	10Ω	22.1Ω
R614	499Ω	499Ω	499Ω	499Ω	221Ω	DNP	DNP	221Ω
R640	DNP	DNP	DNP	DNP	DNP	DNP	DNP	33.2Ω
R650	499Ω	499Ω	499Ω	499Ω	221Ω	499Ω	221Ω	221Ω
R651	10Ω	10Ω	10Ω	10Ω	22.1Ω	18.2Ω	22.1Ω	22.1Ω
R652	499Ω	499Ω	499Ω	499Ω	221Ω	499Ω	221Ω	221Ω
R653	22.1Ω	22.1Ω	22.1Ω	22.1Ω	22.1Ω	10Ω	10Ω	22.1Ω
R7	DNP	DNP	DNP	DNP	DNP	DNP	1K	DNP
R8	DNP	DNP	DNP	DNP	DNP	DNP	DNP	1K

