

MusicParts.Com

Technical Document Distribution

Brand:	Soundcraft
Model	SCM 380, SCM760
Product:	Recorder
Description:	Owners & Service Manual

Musicparts Document Number: 51626 TechTips: No Pages: 166 Dated: 1981

Hello,

Welcome to MusicParts.Com, Inc. your online resource for technical documents and service information. This PDF package may contain information, schematics, parts lists, images, engineering changes, previous versions, circuit descriptions, and many other unique features about the product you have chosen. This document was assembled from a variety of sources and is the result of our many years in the music repair business.

NOTE: Large original over-sized drawings will need to be taped together. We feel this is better than reducing them and losing the fine details.

VIEWING: This document is utilizing PAGE-ON-DEMAND downloading. This will let you navigate to any page without waiting for the entire file to download. Just click ON the thumbnails.

PRINTING: Very Important!

When the print dialog appears, please make sure "**REDUCE TO PAPER SIZE**" OR "**SHRINK OVERSIZED PAGES**" is checked, otherwise you may cut off the edge of the page. This will compensate for your printer's margins and produce a great looking printout. Also please stay online while printing this document to make sure you get all the pages.

Visit us on the web at: <http://www.musicparts.com/>
Email us at: customerservice@musicparts.com



SCM 380/760 RECORDERS

OWNER INFORMATION

Model No. :

Serial No. :

Equalisation standard :

Tape head type & ser. no's.

Erase :

Record :

Replay :

Audio section aligned for :

Soundcraft Magnetics Ltd
9 Gt. Sutton St.
London EC1V 0BX

European Audio Distributors,
20610 Manhattan Place
Suite 120,
Torrance, Ca. 90501, U.S.A

CONTENTS

PART 1: USER INFORMATION

1. Installation
 - 1.1 Unpacking
 - 1.2 Power Supply
 - 1.3 Remote Control
 - 1.4 Audio
 - 1.5 Sync Outputs
 - 1.6 2 inch machines
 - 1.7 Varelco Option
2. Operational Notes
 - 2.1 Reproducing
 - 2.2 Recording
 - 2.2.1 Recording
 - 2.2.2 Overdubbing
 - 2.2.3 Track Bouncing
 - 2.3 Metering
 - 2.4 Routine Maintenance
3. Tape Loading and Unloading
 - 3.1 Mounting the Reels
 - 3.2 Reel Centralisation
 - 3.3 Lacing the Tape
 - 3.4 Reel Height Adjustment
4. Operational Controls
 - 4.1 Deck Plate Controls
 - 4.2 Remote Transport Controls
 - 4.3 Counter and Search to Zero
 - 4.4 Mute Defeat
 - 4.5 Monitor Selection
 - 4.6 Record Selection
 - 4.7 Varispeed
 - 4.8 Dump Edit
5. Alignment
 - 5.1 Standard Settings
 - 5.2 Test Tapes
 - 5.3 Line Level Adjustments
 - 5.4 Tape head alignment
 - 5.4.1 Zenith and Height
 - 5.4.2 Rotation
 - 5.4.3 Azimuth
 - 5.4.4 Erase head
 - 5.5 Audio Channel Alignment
 - 5.5.1 Replay Level
 - 5.5.2 Sync Level
 - 5.5.3 Replay Top
 - 5.5.4 Sync Top
 - 5.5.5 Test tape repetitions

- 5.5.6 Test Tape Removal
- 5.5.7 Record System Adjustment
- 5.5.8 Bias Adjustment
- 5.5.9 Record Level
- 5.5.10 Record Top
- 5.5.11 Final Adjustment

6. Adjustments

- 6.1 Reel Motors
- 6.2 Deck Plate Support Stays
- 6.3 Play Speed Detector
- 6.4 Capstan Speed

PART 2: TECHNICAL INFORMATION

7. Mechanical Subsystems

- 7.1 Pinch Roller Mechanism
 - 7.1.1 Description of operation
 - 7.1.2 Adjustments
 - 7.1.3 Solenoid Body Alignment
 - 7.1.4 Compression spring set up procedure
 - 7.1.5 Return Stop
 - 7.1.6 Pressure Adjustment
- 7.2 Motion Sense Roller
- 7.3 Tape Lift Mechanism
- 7.4 Brake Mechanism
- 7.5 Back Tension Mechanism
 - 7.5.1 General
 - 7.5.2 Linkage Arm Adjustment
 - 7.5.3 End Float Adjustment
 - 7.5.4 End Of Tape (EOT) Switch Adjustment

8. Electrical Subsystems

- 8.1 Audio Channel
 - 8.1.1 Replay Amplifier
 - 8.1.2 Sync Amplifier
 - 8.1.3 Line input Buffer
 - 8.1.4 Monitor Select System
 - 8.1.5 Metering
 - 8.1.6 Line Output Amplifiers
 - 8.1.7 Record Amplifier
 - 8.1.8 Erase/Bias Oscillator
 - 8.1.9 Record Selection Logic
- 8.2 Audio Rack Mother Board
 - 8.2.1 Control Demultiplexing
 - 8.2.2 Master Oscillator
 - 8.2.3 Ready Indicator
 - 8.2.4 Inputs and Outputs
 - 8.2.5 Removal and Servicing
- 8.3 Remote Control Unit (8 track)
 - 8.3.1 Counter and Display
 - 8.3.2 Search System
 - 8.3.3 Record On Selection
 - 8.3.4 Channel Select Clock and Monitor Codes
 - 8.3.5 Monitor Selection

- 8.3.6 Record/Ready Selection
- 8.3.7 Disassembly
- 8.3.8 Adjustment
- 8.3.9 Servicing Hints
- 8.3.10 Reassembly
- 8.4 Transport Logic and Motor Drive System
 - 8.4.1 General
 - 8.4.2 Command Latches
 - 8.4.3 Spool Function
 - 8.4.4 Motion Sensing
 - 8.4.5 Dynamic Braking
 - 8.4.6 Play Function
 - 8.4.7 Play Speed Detector
 - 8.4.8 Stop Function
 - 8.4.9 Auto-stop
 - 8.4.10 Edit
 - 8.4.11 Dump Edit
 - 8.4.12 Motor Control System
- 8.5 Power Supply / Trolley Unit
 - 8.5.1 General
 - 8.5.2 Circuit Description
 - 8.5.3 8 Track PSU assembly
 - 8.5.4 Servicing
- 8.6 Motion Sense Assembly
- 8.7 Noise Reduction Interface
 - 8.7.1 Conditions
 - 8.7.2 Command Generation
 - 8.7.3 Demultiplex and Latch
 - 8.7.4 Speed Adjustment
- 8.8 Capstan Control System
- 8.9 Remote Control Bus - Summary

PART 3: GENERAL INFORMATION

- 10. Fault Finding Guide
- 11. Test Result Summary
- 12. Glossary
- 13. Warranty
- 14. Specifications

PART 4: SCM 760 16 & 24 TRACK RECORDERS

- 17. Operational Controls
 - 17.1 General
 - 17.2 Monitor Selection (Standard Remote)
 - 17.3 Cycle Function
 - 17.4 Record Selection
 - 17.5 Autolocator
 - 17.5.1 Data Entry
 - 17.5.2 Master Zero

- 17.5.3 Data Storage
- 17.5.4 Locate function
- 17.5.5 Capturing tape positions
- 17.5.6 Local Zero
- 17.5.7 Cycle Function
- 17.8.8 Search to Play
- 17.5.9 Recall Key
- 17.5.10 Speed Readout
- 17.5.11 General Notes

17.6 Speed Change

18. Electrical Subsystems

18.1. 24 Track Remote Control - with autolocator

18.1.1 General

18.1.2 Audio Channel Control

- a) General
- b) Shift Register operation
- c) Channel Allocation
- d) Power up sequence
- e) Monitor Command latches
- f) Monitor Selection
- g) Safe / Ready Selection
- h) Record Selection

18.1.3 Transport Control

- a) General
- b) Record Selection
- c) Transport commands and tallies
- d) Varispeed
- e) Locator Controls and display

18.1.4 Computer Board

18.2. Standard Remote Control

18.2.1 Audio Channel Control

- a) Monitor command latches
- b) Muting
- c) Safe / Ready / Record Selection

18.2.2 Transport Control

- a) Counter and display
- b) Cycle Function
- c) Search Function
- e) Record Selection
- f) Speed change

18.2.3 Disassembly

18.3 Interchangeable Headblock

18.4 External Control

18.4.1 Remote Control Bus

- a) Transport functions
- b) Search
- c) Record On
- d) Capstan Control

18.4.2 Synchroniser Interface

1. Installation

1.1. Unpacking

The SCM381-8 is delivered in three cartons. One containing the machine, one the separate power supply and the third the auxilliary case for remote control, three core power cable, two cables linking machine to power supply, remote control cable, varispeed cable and any accessories requested. When the cartons are unpacked the contents should be examined carefully and any deficiency and/or damage should be notified at once to the supplying dealer.

1.2. Power Supply

The power supply should be located at some point where any stray hum field will not affect other equipment, with particular reference to magnetic recording equipment.

The power supply is connected to the machine by two heavy duty cables. One carries DC power for the electronics and solenoids, the other providing AC power for the reel motors. Connection to the AC mains supply is achieved via a 3-core cable colour coded as follows:

BROWN - LIVE
BLUE - NEUTRAL
GREEN - EARTH

A plug suitable for the country of use should be attached to this cable and fitted with a 5A fuse for 200-240V or 10A for 100-120V operation. Ensure that the fuse fitted to the power supply front panel is also of the correct type. Semi-delay or anti-surge fuses are recommended.

ENSURE THAT THE CORRECT VOLTAGE TAPPINGS HAVE BEEN SELECTED ON THE POWER SUPPLY FRONT PANEL BEFORE ANY POWER IS APPLIED TO THE UNIT.

LINE VOLTAGE

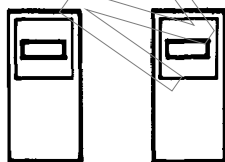

100 v

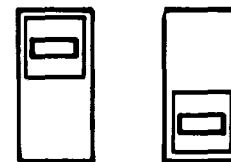

120v

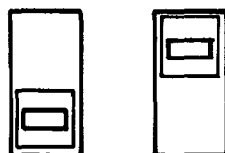

220v

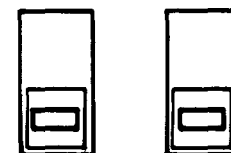

240v

1.3. Remote control

If remote control of the machine is required, the control unit and varispeed unit can be released from the machine front panel by the two captive thumbscrews on each module. Each is simply unplugged and relocated either in appropriate cut outs in the users installation or in the auxilliary remote control case supplied with the machine. These are then reconnected to connectors on the rear panel of the machine by the extension cables supplied.

The L-shaped front panel should then be released by the four remaining thumbscrews, removed and reinserted with the plain face forwards, to retain a clean finish.

1.4. Audio

Audio connections to the machine are via multiway D type connector (see fig 1 -not supplied on machines up to serial no. 0019) or unbalanced 1/4 inch jack socket. These consist of 8 line inputs, 8 line outputs and 8 separate sync outputs. Normally these would be connected to the master studio jackfield for use as required. However if this is not available the line inputs should be connected to the desk line outputs, the line outputs to the desk tape returns and the sync outputs routed as required. The line level controls on the audio channels should be adjusted according to section 5.3 before using the machine.

1.5. Sync outputs

Separate line outputs are provided dedicated to the sync function. These can be used for a number of useful applications such as control inputs on noise gates thus opening the gate in advance of replay signals, or to provide a separate foldback mix to the studio.

Another application for this output is to enable track bouncing to be carried out between adjacent tracks (see section 2.2.3).

37 WAY D-TYPE CONNECTOR

VIEWED FROM REAR OF MACHINE (SOCKET CONTACTS)

OR: VIEWED FROM WIRING SIDE OF FREE CONNECTOR (PIN CONTACTS)

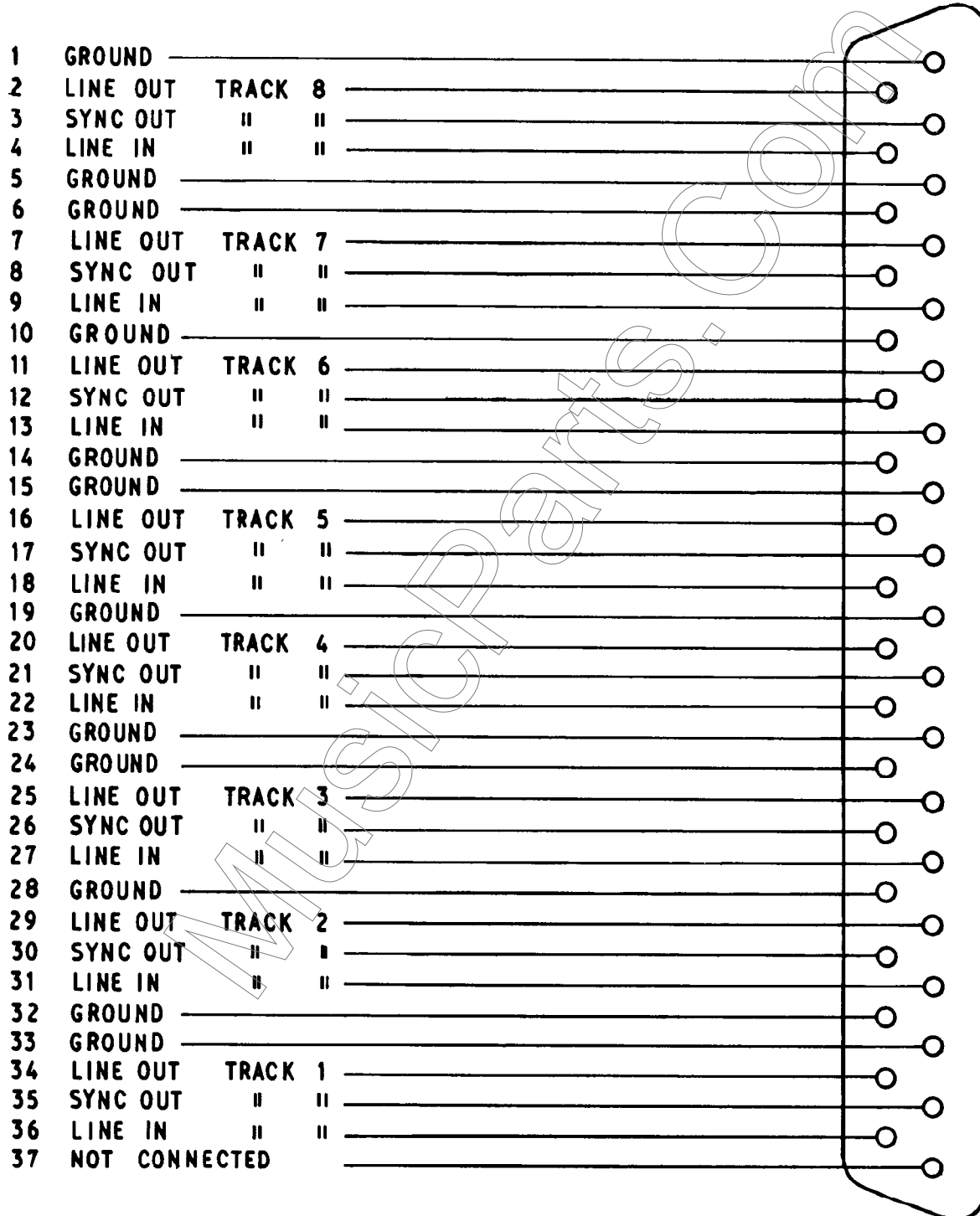

1.6. 2 inch Machines

The SCM 760 series 2 inch machines are supplied in two cartons. One contains the main body of the machine and the other the trolley/PSU, remote control unit and accessories.

A packing list is supplied with the machine and the contents should be checked against this list. Deficiencies or damage should be notified to the carriers and the supplying dealer immediately.

To assemble the machine to the power unit:

- a) Remove the wooden side panels from the unit.
- b) Place the machine onto the trolley unit and align the frame sections visually.
- c) Insert the four bolts (supplied separately) upwards through the four holes in the top plate of the trolley unit to locate in the four captive nuts in the base of the machine. Tighten using the appropriate hexagon key.
- d) Reassemble the wooden side cheeks to the trolley unit.
- e) Connect the AC and DC cables from the trolley unit to the correct sockets on the machine. Refer to section 1.2 for correct setting of the power supply.

DO NOT APPLY POWER TO THE MACHINE WITHOUT FIRST CONNECTING THE REMOTE CONTROL.

Connect the remote control unit via the cable supplied. Ensure that both ends of the cable are firmly plugged in.

1.7. Varelco option.

If the recorder is supplied with the Varelco option, wire up the free connectors as shown in figure 1A opposite, and connect to the machine on the rear panel.

Note that the pin connections are identical to those of the Series 2400 mixing console (i.e. pin A connects to pin A.)

FIG 1A

VIEW - COMPONENT SIDE
VARELCO INTERFACE P.C.B

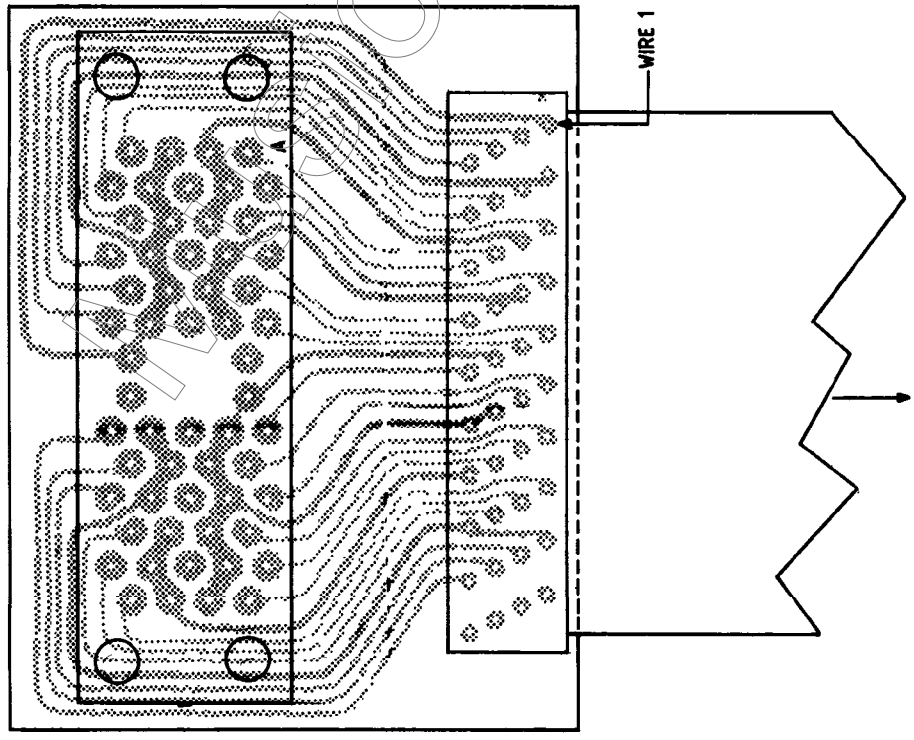

VIEWED FROM SOLDER PIN SIDE OF FREE CONNECTOR

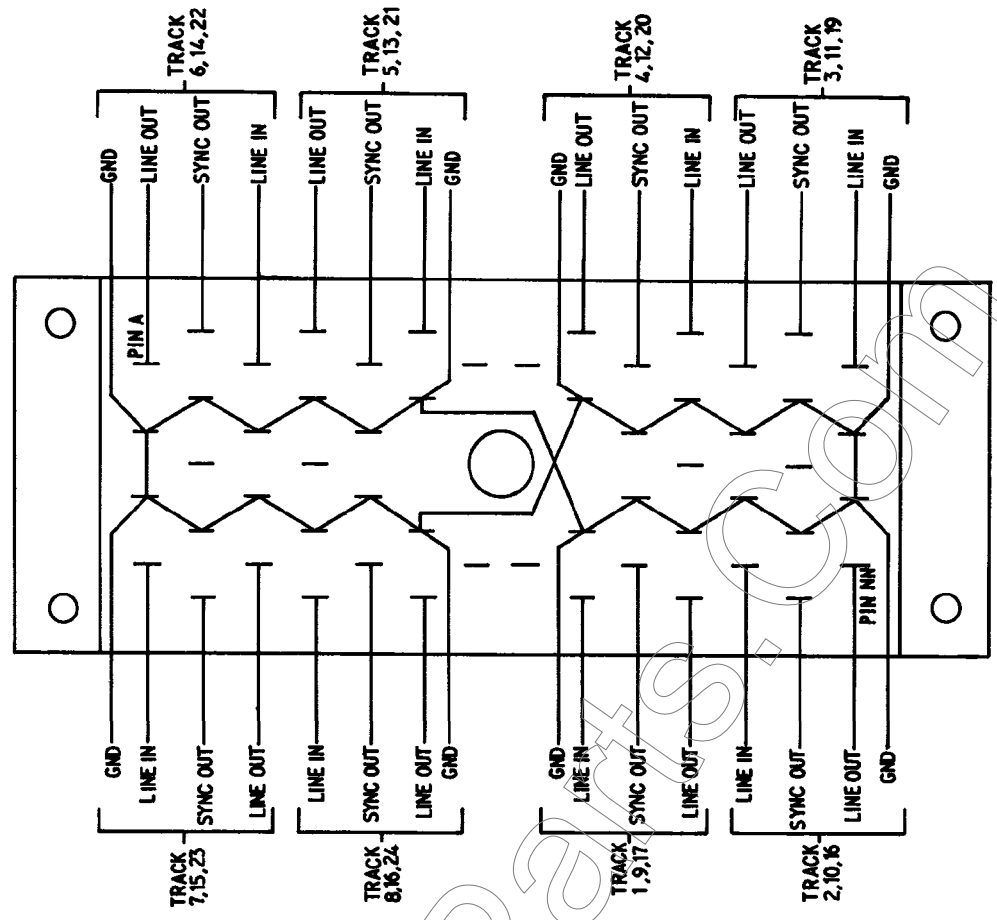

THIRD ANGLE PROJECTION 	TOLERANCE	HOLE INDEX	MATL	DRM	TITLE	
			FINISH	HL	SOUNDCRAFT MAGNETICS LTD	VARELCO WIRING DIAGRAM
			SCALE	TRCD	9-OGREAT SUT'DN STREET	
				CHKD	LONDON EC1V 0BX.	DRG. No.
					TELEPHONE .01-251-3631/2/3	
					TELEGRAMS. SOUNDCRAFT LDN EC1	
					TELEX. UK. No. 21198 USA. No. 224408	

2. Operational Notes

The following notes are a guide to the use of the recorder. Detailed instructions regarding machine operation and maintenance can be found elsewhere in the handbook.

2.1. Reproducing

Pre-recorded tapes can be replayed by loading the tape as in section 3 and selecting the 'play' command on the transport or on the remote control panel.

If replaying tapes recorded on other machines, ensure that the equalisation standard and any noise reduction employed is compatible with your installation.

Sync or replay monitoring can be selected in any combination as described in section 4.5. It is recommended to use replay monitoring for mixdown purposes to take advantage of the better noise performance from the replay head.

It is suggested that any unrecorded tracks should be selected to 'line in' monitoring to avoid any unnecessary tape noise contributions.

2.2. Metering

It is important to note that the internal VU meters are provided for alignment purposes, and do not have true VU characteristics. Thus having carried out the alignment procedures of sections 5.3 & 5.5 the mixing console metering should be used for determining recording levels.

However the machine meters can serve a useful purpose in conjunction with the console meters since they have a peak reading type characteristic. They will thus indicate the peak distortion likely to be occurring on tape. Peaks reaching +4VU on the machine meters (approx 2/3 into the red area) indicate a peak distortion of 1%, while a meter persistently reaching the end stop indicates distortion peaks reaching 3%.

If the mixer has true VU meters, these will apparently indicate a lower recorded level, and give an indication of the average signal level of the programme material.

The compromise to be made is between distortion and dynamic range (or signal to noise ratio). If the important factor is clean, distortion free, recordings then keep an eye on the machine meters to ensure that peaks of signal do not go above (say) +4VU. If, however, the overriding consideration is noise, then pay much more attention to the console meters and do not worry if the machine meters are apparently overloading.

2.3. Recording

There are many different ways of making a recording, and the versatility of the SCM 381-8 gives complete freedom to the user.

2.3.1. Recording

Recording levels to be used should be set up on the mixing console faders using 'line in' monitoring during rehearsal of the track to be recorded. When everyone is ready for a "take", the simplest method is to select the tracks to be recorded to 'record/ready' (see section 4.6.1.), press play and then select 'record mode' (section 4.6.3).

The quality of recording can be checked by selecting 'replay' monitoring at any time. Monitor noise can be kept to a minimum by only listening to 'replay' on those tracks actually being recorded.

Recording should be terminated by pressing the 'record' button (as in section 4.6.5) rather than pressing 'stop'.

The more experienced user can use the individual drop in facility to keep recorded noise to a minimum. This is achieved by entering 'record' mode (section 4.6.3) and then dropping each track in and out as the music dictates.

2.3.2. Overdubbing

Having made the basic recording it is often necessary to "overdub" certain tracks, for example to add solos or to correct mistakes of musicianship. In these cases, 'sync' monitoring must be used in order to keep the new material in synchronisation with the previous recording.

Tracks already laid down, which are not being recorded over should always use 'sync' monitoring. However the new material can either use 'sync' monitor (in which case the previous recording will be heard up to the moment of drop in when the machine will automatically switch over to monitor the new input signal), or line in monitor (if it is desired to listen to the new signal without the possible distraction of noticing the drop in point).

2.3.3. Track Bouncing

A useful technique for increasing the capacity of a multitrack recorder is to use up to six tracks to record backing material, and then to transfer some or all of this material (via a mixing process) to the remaining two tracks. This leaves tracks free to be re-recorded with new material.

The above is only an example of the technique, and tracks may be transferred, or "bounced", in any combination.

The material being "bounced" from one track to another should always use 'sync' mode in order to maintain synchronisation with tracks not being bounced.

When using the main line outputs to do track bouncing, it is always wise to leave at least one track between the source track and the destination

track, since large amounts of crosstalk in sync modes can cause problems of oscillation. However if it is essential that a track be bounced onto an immediate neighbour, this can be achieved by using the dedicated sync line outputs (sections 1.4 & 1.5) which have slightly reduced bandwidth.

This can only be done by connecting the appropriate sync line output to the required line input with a jack lead on the back of the machine. This is easier to do if the inputs and outputs have been wired to the studio patchbay.

Problems of this kind are best avoided by planning the final track arrangement before the first recordings are made, making due provision for any track bouncing that may be required. Note also when planning track layout, that the edge tracks (tracks 1 & 8) on any tape recorder are more susceptible to tape "drop out" due to deficiencies in recording tape manufacture and should be reserved for material which is less critical of sustained HF response (e.g bass guitars or drums).

2.4. Routine Maintenance

Attention to the following points will help ensure long life and maintain good performance from your machine.

2.4.1. Head cleaning (daily)

The front face of the tape heads should be cleaned with soft lint or "cotton buds" moistened with alcohol (isopropyl, ethyl or methyl) prior to each recording session.

2.4.2 Demagnetising (daily)

The tape heads and capstan shaft should be carefully demagnetised with the machine switched off. If using a mains powered type of demagnetiser, ensure that it is drawn slowly away from the heads and capstan shaft, without switching off until well clear of the machine.

2.4.3. Pinch wheel (weekly)

Inspect the pinch wheel for build up of oxide and clean with alcohol when necessary. Failure to keep the pinch wheel clean will result in poor wow and flutter and tape slippage.

NOTE: Use of non recommended cleaning solvents can result in irreparable damage.

Similarly clean all guides and rollers in the tape path on a regular basis.

2.4.4. Fan (weekly)

Inspect the fan filter (on the lower rear panel of the machine) for dust build up and clean with a vacuum cleaner when necessary.

Ensure that the air inlet and the outlet vents do not become obstructed during operation of the machine.

2.4.5. Zenith (weekly)

Inspect the face of each tape head and check that the wear pattern is even over the vertical length of each head.

If there is more wear to one end of the head the the zenith is in need of adjustment- see section 5.4.1.

Note: If an incorrect zenith adjustment has been left uncorrected for long enough to cause severe wear distortion then do not attempt to readjust, since the tape will have worn its own zenith onto the head(s).

2.4.6. Tape head and audio section alignment (monthly)

It is good practice to check these alignments (as described in sections 5.4 & 5.5) either once a month or after every 200 hrs. use (whichever is the sooner).

The record section should be readjusted whenever a different type of tape is used (according to sections 5.5.7 to 5.5.11)

MusicParts.com

3. Tape Loading and Unloading

3.1. Mounting the reel

Spools are mounted on the machine by unscrewing the spool retainer and locating the spool such that the lug on the spool carrier locates in one of the cut outs in the hub.

3.2. Reel Centralisation

Some manufacturers of recording tape supply spools with a slightly oversize central hub diameter. Spools of the correct diameter fit smoothly and snugly over the centralising ring (see fig 2). Should the tape you intend to use be supplied on reels with too large an inside diameter, this will result in the spools not sitting centrally on the spool carrier, with consequent vibration in wind modes.

This can be overcome by moving the rubber centralising ring into the lower groove provided on the spool carrier. If a reel with a smaller I.D. is subsequently used the ring can be moved back to the upper (deeper) groove.

3.3. Lacing the tape

The lacing of the machine is illustrated in fig.3. which shows the tape coming from the supply reel in the following sequence:

- a) outside the tape tension guide
- b) inside the flutter roller
- c) across the face of the headblock where the tape can be dropped between the head screen assembly and the tape lift pins.
- d) between capstan and pinch wheel
- e) outside the motion sense roller
- f) inside the motion sense wrap arm

Note that it is advisable to have power already applied to the machine when loading operations are carried out, to enable the tape to be dropped in behind the head screen.

3.4. Reel Height Adjustment

To ensure optimum tape path and smooth winding properties it is necessary to adjust the height of the spool carriers to suit the tape reels being used.

Height adjustment can be quickly and easily achieved by the following procedure (see fig.2):

FIG 3

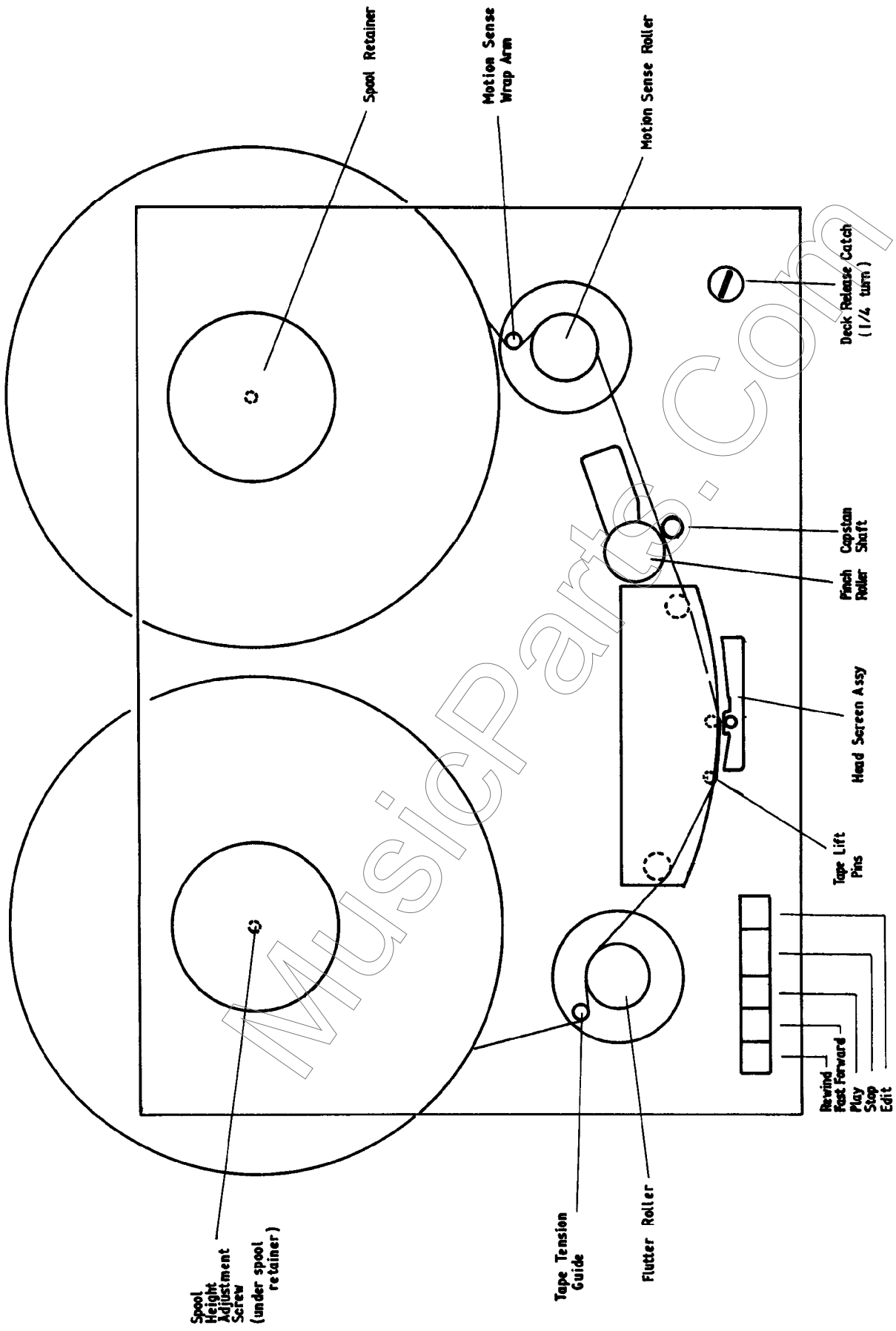

Issue 1	TITLE DECK PLATE LAYOUT AND TAPE PATH		DRAWN T.J.		SOUNDSCRAFT MAGNETICS LTD. 6-8 GREAT SUTTON STREET LONDON EC2Y 0BK. TELEPHONE: 01-281-3831/2/3 TELEGRAMS: SOUNDSCRAFT LON EC1 TELEX: UK No. 21198. USA No. 01-2203	
	MATERIAL FINISH		TRCD		TELEGRAMS: SOUNDSCRAFT LON EC1 TELEX: UK No. 21198. USA No. 01-2203	
	SCALE		CHMD			
TOLERANCE All imperial dimensions ± 0.01 All metric dimensions $\pm 0.25mm$ All angles ± 0.50 Unless otherwise stated		HOLE INDEX				

- 3.4.1 Lace up a reel of the tape to be used as described in section 3.3.
- 3.4.2 Select fast forward (see section 4.1) and wind a length of tape onto the take up spool (say 5 minutes as displayed on the tape position indicator - see section 4.3)
- 3.4.3 Observation of the newly wound section of tape will indicate whether the spool height is in need of adjustment. The new pack should be equally spaced from each of the spool cheeks.
- 3.4.4 Select rewind and wind the tape back onto the supply spool. Examine the pack on the supply spool for equal spacing between spool cheeks. Should either carrier require adjustment, the procedure is as follows:
- 3.4.5 Referring to fig.2
 - a) Remove the spool retainer.
 - b) Slacken the "spool carrier lock screw" by one half turn only.

DO NOT EXCEED THIS AMOUNT OR LOCATION OF SPOOL CARRIER TO FLAT ON THE MOTOR SHAFT WILL BE LOST

- c) Turning the "height adjust screw" will now move the carrier up or down as required.
- d) Clockwise rotation of the screw moves the carrier down.
- e) Counter-clockwise moves the carrier up.
- f) 1.5 turns of the "height adjust screw" moves the carrier by 1mm.
- g) Use hexagon wrenches of the size recommended in fig.2.
- h) When the correct setting has been achieved, tighten the "spool carrier lock screw" firmly and run the tape as in 3.4.3 and 3.4.4 above to confirm.

M
ISSUE 1
12.3.82

MACHINE VIEWED FROM L/H SIDE

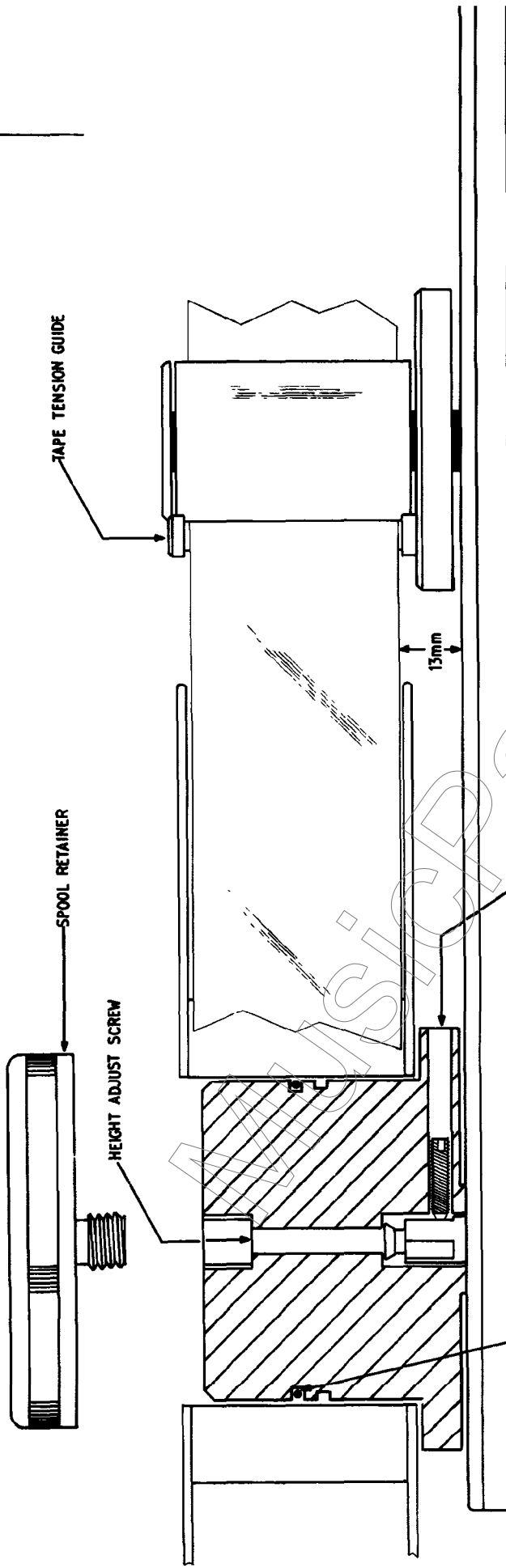

SPOOL CARRIER LOCK SCREW

RUBBER CENTRALISING RING

SCREW DETAILS

HEIGHT SCREW = M4 CSK SKT SCREW

LOCK SCREW = M5 SKT. SET SCREW

HEXAGON WRENCH DETAIL

M5 AND M4

	TOLERANCE	HOLE INDEX	MATL	DRM	TITLE
			FINISH	HL	SPOOL HEIGHT ADJUST DETAIL
		SCALE	CHKD	TRCD	DRG No FIG.2
					SOUNDCRAFT MAGNETICS LTD 9-HOGREAT SUTTON STREET LONDON EC1V 0BK TELEPHONE 01-251 3631/2/3 TELEGRAMS SOUNDCRAFT LDN EC1 TELEX UK No 21198 USA No 224408

4. Operational Controls

4.1. Deck plate controls

Local illuminated controls for basic transport operation are provided on the deck plate (see fig 3). These are: rewind (blue), fast forward (blue), play (green), stop (yellow), and edit (white). The logic circuitry associated with these controls ensures that any mode can be selected at any time without danger of mishandling the tape. Edit mode can only be entered when the machine is in "stop" and will then defeat the tape lift mechanism and apply tension to the tape. This enables the tape to be passed across the heads by single hand operation of either reel. To exit from the 'edit' mode press the edit button again.

4.2. Remote transport controls

The control panel (see fig 4) contains duplicate illuminated transport controls, with the exception of edit. Both sets of buttons are operative simultaneously.

4.3. Counter and search to zero

Real time minutes and seconds (at 38.1cm/s) are displayed on the tape position indicator which can be set to zero at any point on the tape by selecting the 'reset' button. Selecting the 'search' button at any time will illuminate the associated LED and cause the machine to wind to the preset zero point with an accuracy of 1 or 2 inches of tape.

Should it be required to go immediately into "play" after returning to zero, this can be accomplished by selecting the 'play' button at any time while the 'search' LED is illuminated.

'Search' mode can only be interrupted by pressing 'stop'.

4.4. Mute Defeat

During all spooling modes (including 'search') all audio channels are automatically muted. Should it be required to listen to the "monkey chatter", this facility can be overridden by selecting 'mute defeat'.

4.5. Monitor selection

The control panel features full control over, and indication of, the current monitor status of the line outputs.

Each channel line output can adopt one of three monitor states: "Line", direct monitoring of the input signal; "sync", monitoring previously recorded signals using the record head; and "Replay", monitoring signals either previously recorded or currently being recorded

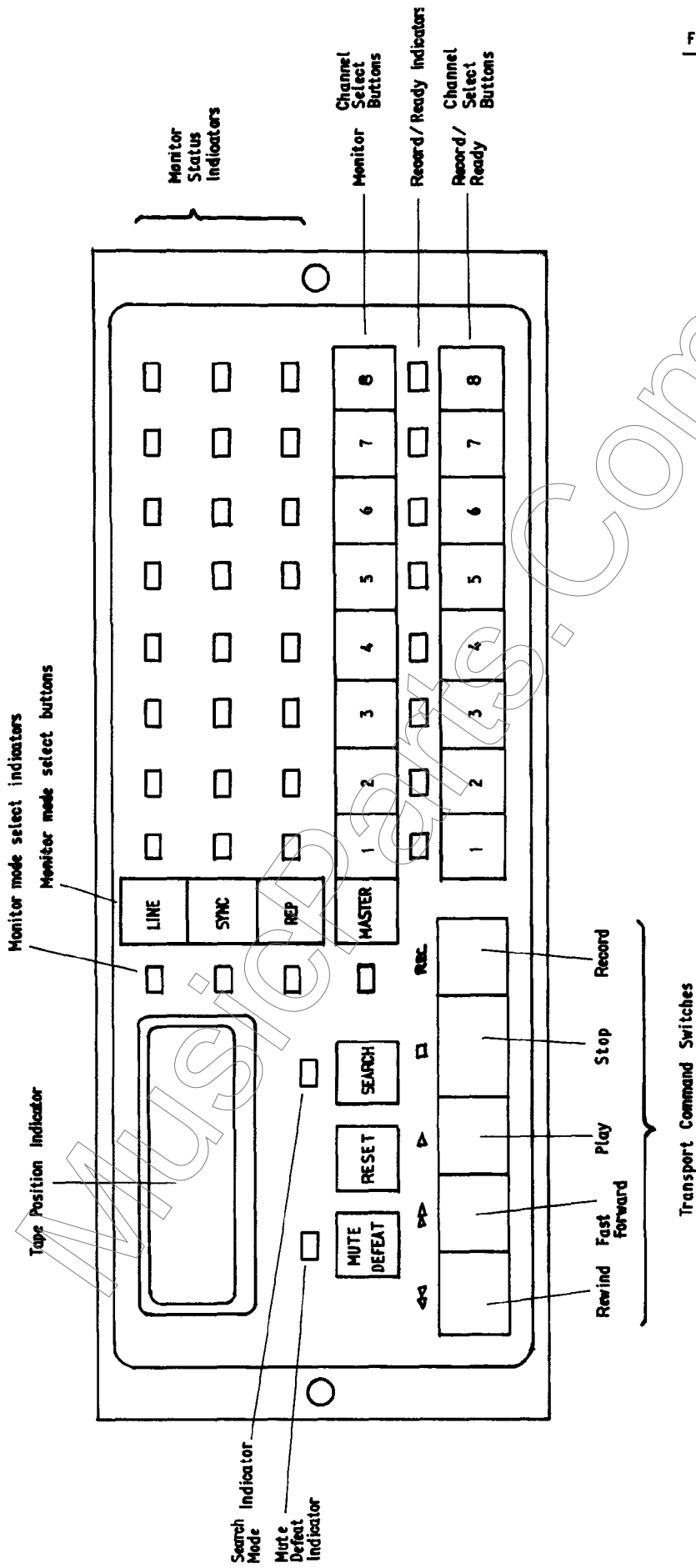

FIG 4

TOLERANCE All imperial dimensions ± 0.01 All metric dimensions $\pm 0.25mm$ All angles $\pm 0.50^\circ$ Unless otherwise stated	HOLE INDEX	MAIL FINISH SCALE	DRM T.I. TRGD CHKD	SOUNDCRAFT MAGNETICS LTD. 5-8 GREAT SUTTON STREET LONDON EC2V 0BX. TELEPHONE 01-251-3631/2/3 TELEGRAMS. SOUNDCRAFT LDN EC1 TELEX UK.No. 2199. USA. No. 01-2203	
				TITLE REMOTE CONTROL UNIT CONTROL & INDICATOR LAYOUT	DRG. No.

using the replay head.

The channels can be individually selected to any combination of monitor states by first selecting the monitor condition required (i.e. line, sync, or rep) and then pressing the channel selection buttons for those channels which are required to adopt that state. This process can be repeated for other selections until the desired monitor combination is achieved. E.g. to monitor 'line in' on tracks 3 and 7 and 'sync' on tracks 1,2,4,5,6 & 8.

PRESS:

Line	3	7	Sync	1	2	4	5	6	8
------	---	---	------	---	---	---	---	---	---

In a large number of situations it will be required that all eight tracks follow the same monitor condition. This is achieved by pressing the 'master' monitor selection button, whereupon all eight tracks are controlled by the mode selection buttons. Pressing the 'master' button again returns the monitor state to the last individually entered combination.

Note 1. Pressing a "monitor channel select" button automatically returns the matrix to individual selection mode.

Note 2. The VU meters on the front panel of each channel read the signals dictated by the monitor select matrix.

Note 3. Channels selected to monitor the sync function automatically read 'line in' when in the record mode. This is not indicated by the LED matrix.

4.6. Record selection

Underneath the monitor channel select buttons is a row of 'record/ready' channel select buttons, with associated LED indicators. These give comprehensive control over the machine recording functions.

4.6.1 Each button has a bistable action; pressing once causes its LED to commence flashing along with the LED on the front panel of the corresponding channel in the machine. Pressing again cancels the function.

4.6.2 A flashing LED indicates that a channel is in the 'ready to record' mode and that if 'record' is selected (see below) that channel will commence recording. This condition is indicated by the flashing LED becoming continuously illuminated.

4.6.3 'Record' mode is selected by holding the 'play' button while pressing and releasing the illuminated 'record' button.

4.6.4 Having entered 'record' mode individual tracks can be 'dropped in' and 'dropped out' by the record/ready

channel select buttons.

4.6.5 Overall 'drop out' of all tracks is achieved by repressing the 'record' button. The LED's on selected tracks will then revert to flashing indications.

4.7 Varispeed

The varispeed module provides control over capstan speed over the range +15% to -50%.

Selecting 'varispeed' position passes tape speed control to the variable speed control (VSC) potentiometers giving the full range of tape speed variation.

The coarse control adjusts over the full speed range, and fine control gives an approximate +10% range about the selected speed.

Reselecting 38 cm/s returns the tape speed to the calibrated preset operating speed.

Note. The SCM361-8 is a single speed machine and although the speed is variable over a wide range, the equalisation and bias adjustments are unaffected by the varispeed control. If it is required to record continuously at a lower tape speed the amplifier calibration presets will require readjustment.

4.8. Dump Edit

Recorders manufactured from December 1981 incorporate a dump edit facility. This mode is entered by selcting the normal "edit" mode followed by pressing the "play" button. This will cause the pinch wheel to engage and draw tape across the heads. The take up motor will remain stationary allowing the tape to fall freely.

Care should be taken that the loose tape does not catch on any transport component.

To leave dump edit mode press either "stop" or "edit". Selecting any other button will cause the machine to fall into "auto stop".

N.B. DAMAGE TO THE TAPE can occur if the recorder is forcibly taken out of auto-stop (by manually lifting the tension arm) having reselected edit mode, or by attempting to enter any other mode before the tape has been correctly re-laced.

5. Alignment

5.1. Standard settings

The SCM381-8 provides the user with comprehensive facilities for keeping the machine in perfect alignment for all major tape types.

Unless instructed otherwise the machine has been delivered fully aligned for immediate use using tape according to the standard shown below. The relative levels are independently adjustable over the ranges indicated.

For a meter indication of 0VU:

Input level	+4dBv	(-10 to +20dBv)
Recorded fluxivity	320 nWb/m	(180-640 nWb)/m
Output level	+4dBv	(-10 to +10dBv)

5.2. Test Tapes

A test tape of suitable quality is essential to the correct alignment of any tape recorder and since it represents a substantial investment it should be handled with care:

Always store test tapes in a clean dry atmosphere away from magnetic fields such as power supplies, loudspeakers etc. A stable temperature of around 25°C is to be recommended.

Apart from the general need to keep a machine free of stray magnetic fields, all components in the tape path should be demagnetised before using a test tape.

5.3. Line level adjustments

The controls on the front panel of each channel are divided into two categories: internal machine alignment, and external interface levels.

To align the external interfaces set the mixer slate oscillator to give a 1kHz tone on the group outputs. Adjust the group faders to give 0VU on the desk meters.

Select 'line in' monitoring on the machine and adjust the 'Line in' potentiometers to give a reading of 0VU on the channel meters.

Without altering the machine monitor status, select tape return monitoring on the mixer. Adjust the machine 'Line Out' potentiometers to give a reading of 0VU on the mixer VU's.

Adjust the 'Sync Out' potentiometers to suit the equipment with which they are to be used.

Note. If your studio line level is +4dBv the above procedure can be omitted as the machine is supplied pre-adjusted to this level.

FIG 5

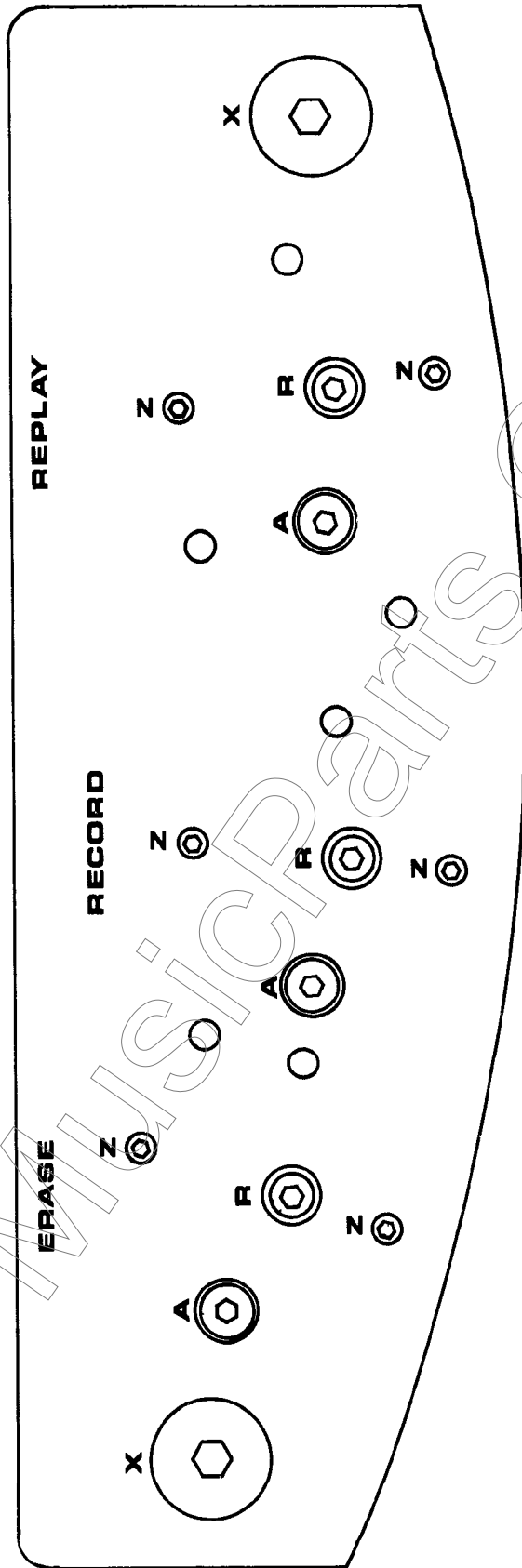

- Z Zenith & height adjustment
- R Rotation adjustment
- A Azimuth adjustment
- X Head block fixing screw

TOLERANCE All imperial dimensions ± 0.01 All metric dimensions $\pm 0.25\text{mm}$ All angles $\pm 0.50^\circ$ Unless otherwise stated	HOLE INDEX	MATL	DRN T.J.	TITLE TAPE HEAD ADJUSTMENTS
		FINISH	TRCD	
		SCALE	CHKD	DRG. No.

SOUNDCRAFT MAGNETICS LTD
5-8 GREAT SUTTON STREET
LONDON EC1V 0BX.
TELEPHONE. 01-251-3631/2/3
TELEGRAMS. SOUNDCRAFT LDM EC1
TELEX. UK.No. 21198 USA.No.01-2203

5.4. Tape head alignment

Prior to delivery the tape heads are critically aligned for zenith, height, azimuth and rotation (or wrap). However to ensure even head wear and optimum performance the heads should be periodically checked for good alignment.

5.4.1 Zenith and height

Referring to fig. 4 the zenith and height should be adjusted using a high accuracy square to refer the front face of the head to the precision surface of the deck plate, together with a length of new tape to check the height of the tape path in relation to the track format of the heads.

Correct zenith is achieved when there is no light visible between the head square and the front face of the head.

Correct height is achieved when the tape is centrally located between the top and bottom cut-aways on the record and replay heads, and when equal amounts of the erase head gaps are visible above and below the tape path.

The height can be adjusted without affecting the zenith by alternately turning each of the zenith screws by 1/4 turn at a time.

Should a head square be unavailable, the zenith can be set by sighting across the face of the head assembly and checking that the front face of the replay head is parallel to the head block exit guide, the record head is parallel to the replay head, and the erase head to the record head. Alignment can then be confirmed by ensuring the erase head is parallel to the entry guide.

Should this procedure be used to zenith the heads, the alignment should be checked at the earliest opportunity using a head square. A tool kit containing this along with the necessary hexagon wrenches is available on application.

5.4.2. Rotation (or wrap)

Head rotation and azimuth can only be adjusted by the use of a good quality test tape. Using the high frequency section (10kHz) of the test tape, with the machine selected to replay monitoring, release the central 'rotation' screw for the replay head and turn the head to obtain the maximum output on the VU meters. Retighten the rotation screw.

5.4.3. Azimuth

A very good approximation to correct azimuth can be obtained by using the same section on the test tape and adjusting the 'azimuth' adjustment screw for maximum overall output, as indicated on the VU

meters.

This procedure is repeated for the record head with the machine selected to "sync" monitoring.

A more accurate adjustment of azimuth can be achieved by the use of a double beam or a dual channel chopped trace oscilloscope. One channel of the oscilloscope is connected to track 2 and the other to track 7 output. With the machine selected to replay monitoring and starting at the low frequency end of the frequency response section of the test tape adjust the replay head azimuth so that successively increasing frequency tones remain in phase between the two tracks.

Select the machine to sync monitoring and repeat the procedure with the record head azimuth adjusting screw.

REMOVE THE TEST TAPE AND RETURN IT TO SAFE STORAGE

5.4.4. Erase head

Erase head rotation and azimuth are considerably less critical and can be adjusted by eye for good tape path and wrap angle.

Rotation adjustment is made such that the tape has an equal amount of wrap angle on each side of the head.

Azimuth adjustment can be done using the head square to indicate that the centre-line of the head is vertical to the deck plate.

5.5. Audio channel alignment

Alignment of the channel electronics is accomplished via the recessed preset potentiometers, accessible through the front panels. These adjust the record, replay and sync amplifiers to provide the required recorded level and frequency response. Before proceeding with the adjustment procedure, the desired tape fluxivity for a 0VU indication must be decided.

The machine is supplied pre-aligned such that 0VU indicates a recorded fluxivity of 320 nWb/m which is a good compromise between a lower recorded level (min 180 nWb/m) which gives better frequency response and distortion along with improved headroom, and a higher level which gives better overall signal to noise. The consistently improving quality of tape manufacture available for studio use means that lower recorded levels are unlikely to be required.

Replay and sync amplifiers are adjusted with the use of the test tape (see section 5.2.).

5.5.1. Replay level

Select replay monitoring and using the reference level section of the test tape adjust the 'replay level' presets to give a reading on the internal VU's as shown in the chart below.

Test tape reference level	180	200	250	320	510	(nWb/m)
Desired 0VU level	180 0VU	+1VU	+3VU	+5VU	-	
(nWb/m)	200 -1VU	0VU	+2VU	+4VU	-	
	250 -3VU	-2VU	0VU	+2VU	+6VU	
	320 -5VU	-4VU	-2VU	0VU	+4VU	
	510 -9VU	-8VU	-6VU	-4VU	0VU	
	640 -11VU	-10VU	-8VU	-6VU	-2VU	

5.5.2. Sync level

Select sync monitoring and repeat the procedure for the 'sync level' presets.

5.5.3. Replay top

Select replay monitoring and using the frequency response section of the test tape adjust the 'replay top' presets for a flat frequency response.

5.5.4. Sync top

Select sync monitoring and repeat the procedure for the 'sync top' presets.

5.5.5. Test tape repetitions

If the test tape contains repetitions of the frequency response section, this can be used to double check the alignment.

5.5.6 REMOVE THE TEST TAPE AND RETURN IT TO SAFE STORAGE.

5.5.7. Record system

The record amplifier and bias adjustments should be carried out using a length of tape of the type to be used on the machine. Select line in monitoring and send a 10KHz tone from the mixer to read (say) -4VU on the machine VU meters.

5.5.8. Bias adjustment

Select replay monitoring and put the machine into 'record' on all eight tracks (see section 4.6.). For each track in turn, start with the 'bias' preset in the fully anticlockwise position and gradually increase the bias until a peak reading is obtained on the VU meter. Continue increasing the bias until the replay signal drops by an amount indicated in the tape manufacturers specification. E.g. Ampex 456 and BASF SPR50 LHL:-3dB, Scotch 256:-2dB.

5.5.9. Record level

Select line in monitoring and send a 1KHz tone from the mixer. Note the input level as read on the machine VU's. Select replay monitoring and put the machine into 'record'. Adjust the 'record level' presets such that the machine VU's read the same values as for line in monitoring.

5.5.10 Record top

Repeat the procedure of section 5.5.9. using a 10KHz tone and adjusting the 'record top' presets.

5.5.11 Final adjustment

The machine should now be in perfect alignment and this can be confirmed by the use of a suitable signal generator. Any minor deviations from an ideal frequency response can be corrected by further adjusting the 'record top' presets.

6. Adjustments

6.1. Reel Motors

All recorders (including 8 track machines) manufactured from December 1981 have had a number of user adjustments replaced by fixed resistors, factory selected for optimum performance.

The only user adjustments remaining are for setting play tension. These are located on the transport logic board which is mounted behind the upper rear panel of the recorder.

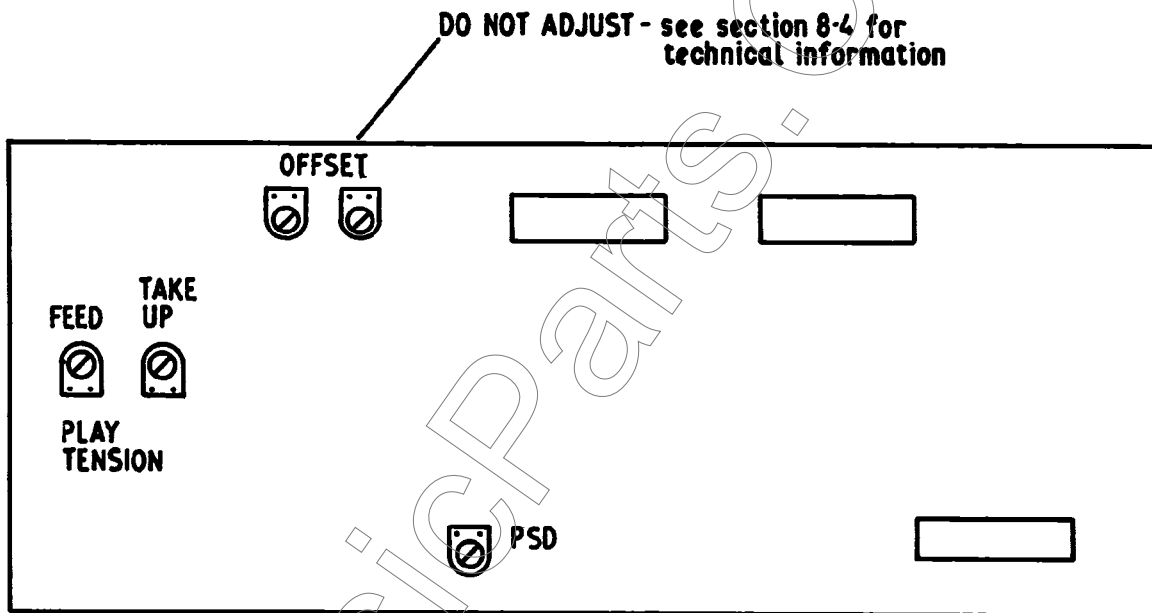

For PSD adjustment see section 6.3

The take up motor play tension pot should be adjusted for reasonable tension between the pinch roller and the motion sense roller.

For 1 inch machines this should be 100 grams approx. and for 2 inch machines about 200 grams. See section 8.4.12 for further information.

The supply motor 'P.T.' preset should be adjusted for best speed stability from one end of the tape to the other. This is achieved by recording a tone of known frequency throughout the length of a reel of tape, turning the reels over and replaying the tape backwards monitoring the resulting frequency. Too low a frequency indicates too much back tension, and vice versa. Experience has shown that a voltage range of 53 to 43V from beginning of spool to end of spool produces the best approximation to optimum tension of 100 grams.

Motor voltages on your machine in the pre-delivery test are recorded in section 11

6.2. Deck support stays

The friction support arms for the deck plate can be adjusted for speed of descent. Undo the deck release catch (fig 3) to enable the deck plate to be lifted.

The end stops on the support arms enable the deck to stand alone in the open position. Firm pressure on the deck plate will free the lock and allow the transport to descend smoothly and evenly to a horizontal position. Should the transport come down too quickly or too slowly the support arms can be adjusted accordingly (see sketch).

Screwing the threaded ring into the body of the pivot assembly reduces the friction and increases the speed of descent. Unscrewing the ring has the opposite effect.

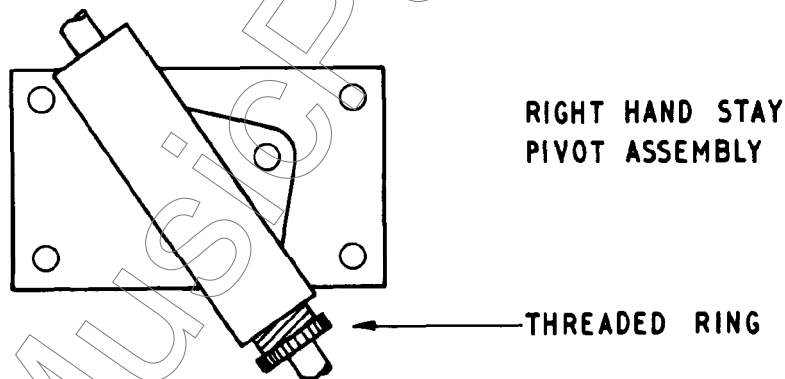

6.3. 38 cm/s detector

The play speed detector circuit can be adjusted by means of preset 'PSD' on the transport logic board, mounted on the upper rear panel of the machine (see fig 6)

This should be adjusted such that the pinch wheel engages the capstan shaft after the tape has been set in motion, and for minimum slip through the pinch/capstan assembly at the point of engagement.

When properly adjusted, this circuit enables fast acquisition of wow and flutter stability and avoids the possibility of damage to the tape due to slippage through the pinch/capstan assembly, or sudden application of tension.

6.4. Capstan Speed

Fixed speed adjustment presets are located on the noise reduction interface board mounted on the lower rear panel of the recorder. Some 16 track 1 inch machines have this board mounted behind the upper front panel (above the audio channels).

For further information see section 8.7.4.

Recorders supplied with the A option can use the speed readout facility for setting fixed speed (see section 17.5.10). Otherwise it is necessary to use a test tape and frequency counter as in section 4.7 .

MusicParts.com

7. MECHANICAL SUB-SYSTEMS

7.1. Pinch roller mechanism

7.1.1. Description of operation

The purpose of the pinch roller in conjunction with the capstan is to maintain a constant tape speed across the tape heads in the play mode.

The pinch roller mechanism consists of a D.C. solenoid acting through a compression spring via a lever; transferring pressure from the pinch roller onto the capstan shaft.

The mechanism may need adjusting if any of the following faults occur:

- 1) High wow and flutter
- 2) Tendency for the tape to ride up or down the capstan shaft
- 3) Excessive time to reach speed stability on entering 'Play' mode

7.1.2 Pinch mechanism adjustments

Should the need arise for any adjustments to the pinch mechanism, it is important that any checks should be made in the following order.

- [1] Solenoid body alignment
- [2] Pinch compression spring set up procedure.
- [3] Pinch roller return stop
- [4] Pinch roller pressure adjustment.

7.1.3 Solenoid body alignment

Switch off machine. Refer to diagram 8091.

Turn the deck release catch (fig.3) anti-clockwise with a small coin, lift the transport until the support stays latch firmly.

This adjustment should be carried out if any snagging of the solenoid plunger occurs within the core.

Using a 2 point "Pozi-drive" screwdriver slacken the four M.4. Pozi screws "G". Push the plunger in and out of core, whilst rotating the solenoid body until plunger runs without restriction, finally tighten screws "G" and re check.

7.1.4 Pinch compression spring set up procedure.

Switch off machine. Refer to diagram 8091

Turn deck release catch anti-clockwise with small coin, lift transport until end stops latch firmly.

Before any adjustments are made the following check should be made.

By pushing control rod "C" towards solenoid until pinch roller just touches the capstan shaft, a further 4-5mm of travel should be possible before the rod cannot be pushed any further, if this travel is incorrect the following procedure should be carried out:-

a] Release pinch screw "F" on pinch control arm using a 3mm Allen key.

b] Ensure that pinch control arm is operating approx 2 degrees either side of 90 degrees to pinch control rod "C", if necessary adjust from locking collar "H" using a 1.5mm Allen key.

c] Push pinch roller against capstan shaft and retain firmly against capstan shaft with a suitable elastic band.

d] Push control rod "C" towards solenoid until plunger bottoms in core, then allow control rod to return 4-5mm and tighten screw "F" on pinch control arm.

e] Remove elastic band.

f] Finally check adjustment by pushing control rod "C" towards solenoid, the pinch roller should engage with the capstan shaft 4-5mm before the plunger bottoms in the solenoid core [as described in the initial check in this section].

N.B. The core shaped coil spring fitted to solenoid plunger is a mechanism return spring and should not be adjusted.

7.1.5 pinch roller return stop

Switch off machine. Refer to diagram 8091

The pinch roller should come to rest 3-4mm from the capstan shaft [this applies to the machine in the stop, and fast wind mode as well as when the machine is switched off]; this ensures that the tape does not touch either capstan shaft or pinch roller except when in the play mode, excessive clearance will result in solenoid mechanism over travel with consequent inability for the pinch mechanism to operate.

Adjustment is simply carried out by altering the position of collar "D" using a 1.5mm Allen key to achieve the desired clearance. Ensure that the rubber buffer "J" is always moved together with collar "D".

7.1.6 Pinch roller pressure adjustment

Switch off machine. Refer to diagram 76091

The pinch roller operating pressure is factory set to:-

- 1" machines: 1.4kgs.
- 2" machines: 1.9 - 2.0kgs.

A 2kg. cylinder spring balance fitted with a 90 degree 1/8" [3mm] diameter hook will be needed for checking pinch roller pressure.

- a) Load tape onto machine.
- b) Release 1/4 turn fastener on transport and raise to locked position.
- c) Defeat variable PSD facility (see section 8.4.7). Switch on power and select play mode.
- d) Connect hook of spring balance to hole "A" in pinch control arm taking care not to foul rotating motion sense disc.
- e) Stop take-up spool from rotating by holding spool retainer and allow tape to spill freely over right hand side of machine.
- f) Pull slowly on spring balance until tape is heard to slip between the capstan shaft and the pinch roller, resulting in the tape coming to a standstill. At this point the spring balance should read 1.4kg [1" tape] 1.9-2.0kgs [2" tape]. Re-check 2 or 3 times before deciding if adjustment is required.
- g) If pressure is incorrect then adjust as follows:-

Unlock 2xM5 nuts "B", using 2x8mm A.F. spanners, on control rod "C". Rotate inner nut clockwise to increase pressure or anti-clockwise to decrease pressure. When correct pressure has been achieved (re-check at least twice with the spring balance), hold inner nut with spanner so as not to alter setting and lock outer nut to the inner one tightly with second spanner.

N.B. The amount of adjustment required should not be more than a few turns if the "pinch compression spring set up procedure" described in section 7.1.4 has been carried out correctly.

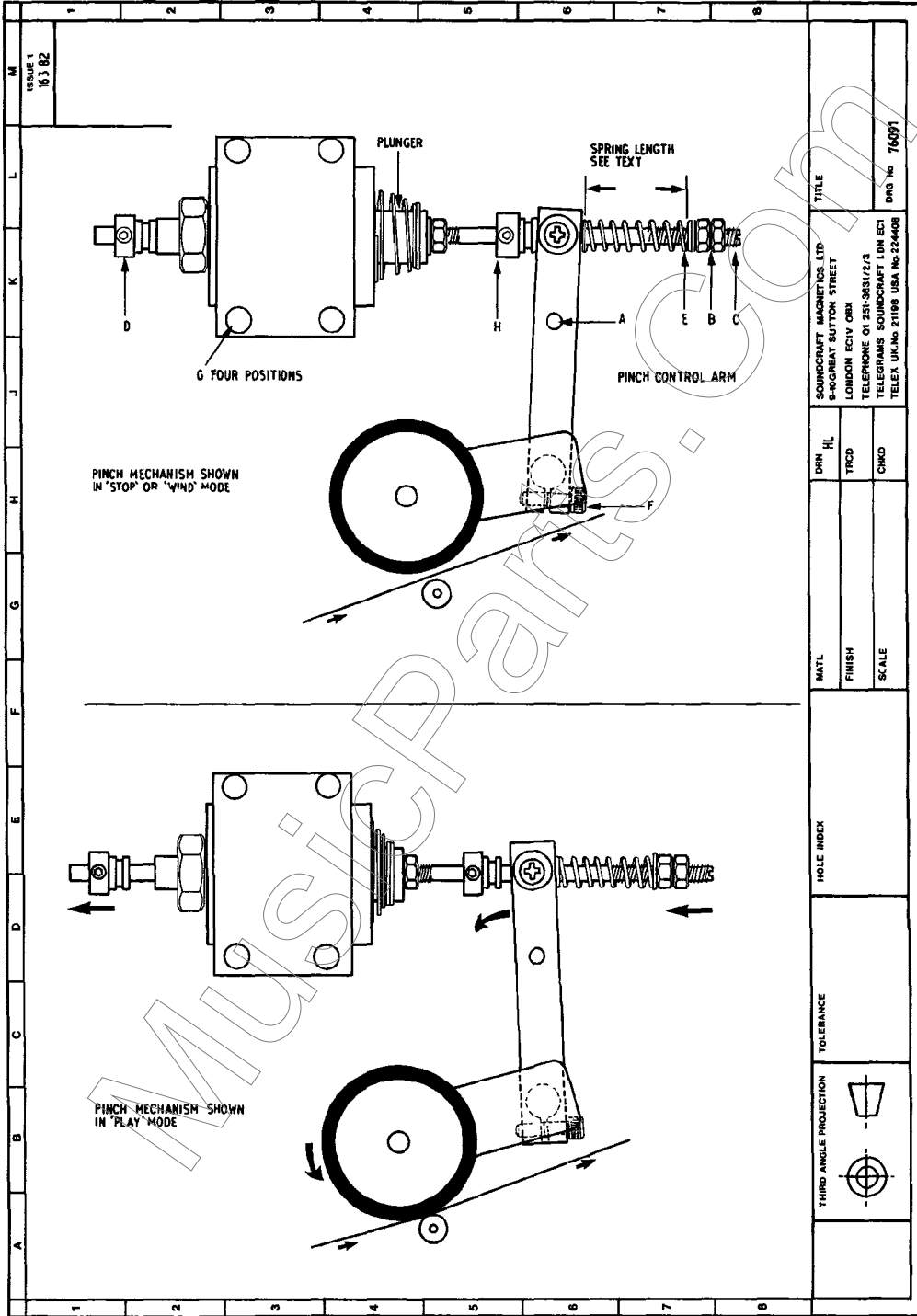

1	2	3	4	5	6	7	8	REVISION 163 B2			
TITLE SOUND-CRAFT MAGNETICS LTD 9-10 GREAT SUTTON STREET LONDON EC1V 0BX TELEPHONE 01 251-3631/2/3 TELEGRAMS SOUND-CRAFT LDN EC1 TELEX UK-No 21198 USA No 224408								DRG No 76091			
DRN HL TRCD CHKD			MATL FINISH SCALE			HOLE INDEX TOLERANCE			THIRD ANGLE PROJECTION 		

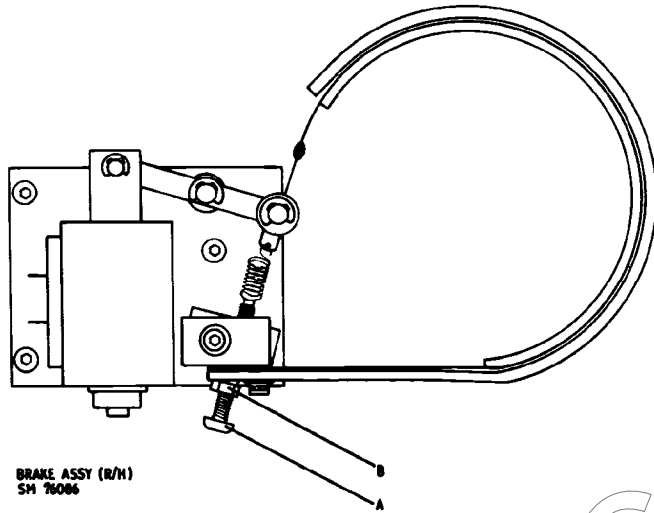

TITLE
BRAKE ASSY (R/H)
DRG No 76086

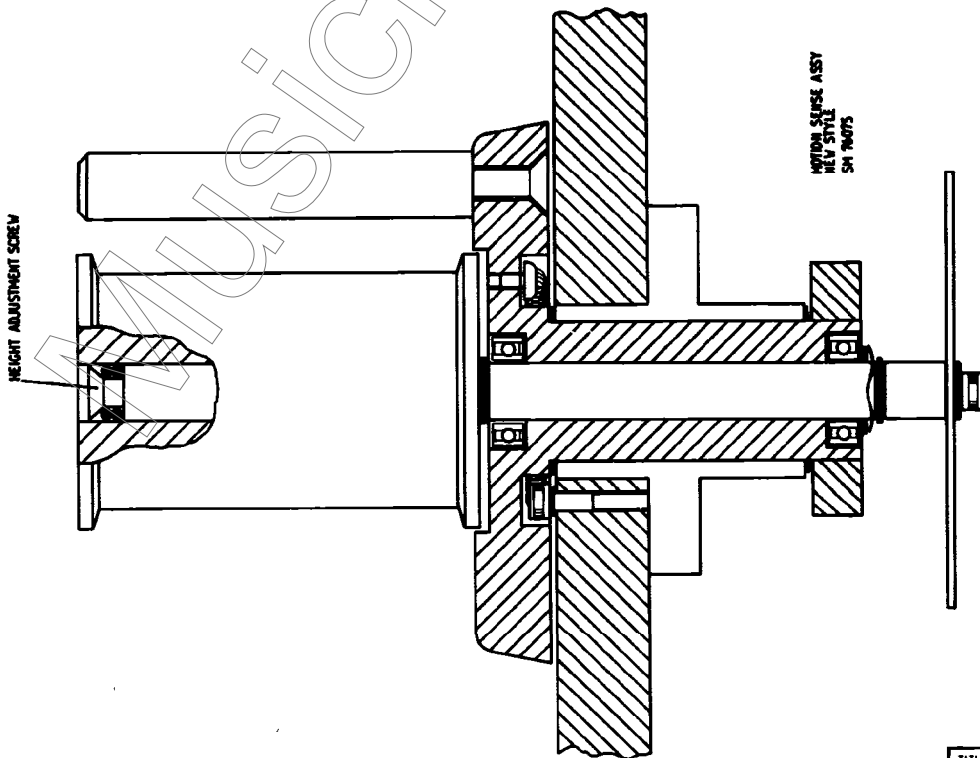

TITLE
MOTION SENSE ASSY NEW STYLE
DRG No SM 76075

h) Should a spring balance not be available, the length of spring E (in diag. 76091) can be taken as a rough guide to setting correct pinch pressure. Measuring the spring in STOP mode should give the following lengths:

1" machines: 32mm. - 1.4kgs.
2" machines: 27-28mm. 1.9-2.0kgs.

If adjustment is required, use the method in (g) above.

7.2 Motion sense roller adjustment

The motion sense roller is adjustable for height and is factory set at the correct height.

However should the roller need adjusting [indicated by poor tape path between capstan and take-up spool and assuming that spool heights are correctly set- see sect. 3.4], a locking screw is sited in the centre of the roller:

To release, hold the motion sense roller whilst turning the screw anti-clockwise using a 2mm or 2.5mm Allen key approximately 2.5 turns. Should it fail to release, carefully hold the motion sense disc below transport to facilitate release. The height can then be adjusted until a perfect tape path is achieved [approx. 13mm from the surface of the transport] then tighten the allen screw ensuring that the roller does not move whilst tightening.

7.4 Brake mechanism

Refer to diagram 76086

The transport is fitted with 2 stand-by, self-compensating, solenoid operated, mechanical brakes. Should adjustment be needed access is via the logic door at the top rear of the machine.

To adjust the strength of the brakes:

- a) Switch off the machine
- b) Using a No 1 point Pozi screwdriver to hold the adjusting screw "A", turn the 4mm nut "B" using a 7mm A/F spanner clockwise to increase braking, anti-clockwise to weaken braking.

N.B. Under no circumstances must the Pozi-screw be turned as this will damage the brake tension spring.

7.5 Back tension mechanism

7.5.1 General

The servo control information for the feed motor is derived from a precision potentiometer mechanically linked to the flutter roller tension system. Also incorporated is an end of tape switch.

Should the mechanism exhibit sticking, check as follows.

Refer to diagram 8088.

Switch off the machine and ascertain which of the following is the cause:

[a] The alignment of potentiometer linkage arm "A" which should be parallel to arm "F". Refer to 7.5.2

[b] End float in back tension bearing shaft can be checked by moving pulley "C" up and down. A small amount of play should be present, refer to 7.5.3.

[c] Incorrect adjustment of microswitch arm "B" which should operate within 5 degrees of end stop. Refer to 7.5.4

[d] Damaged potentiometer resulting in excessive friction.

The adjustments are as follows except in the case of [d] where a replacement will be necessary.

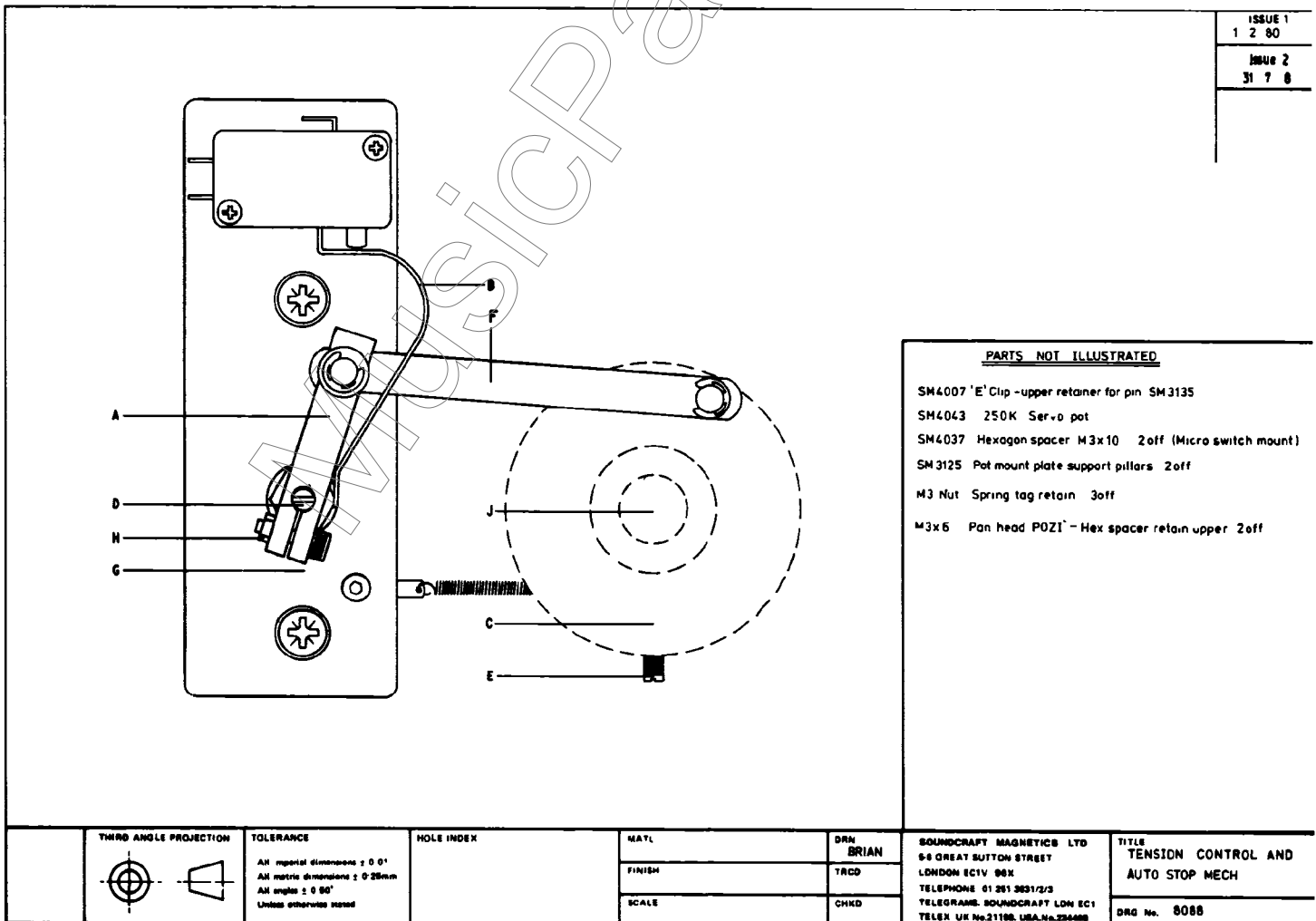

7.5.2 Linkage arm adjustment

To adjust the potentiometer linkage arm "A":-

Release socket screw "G" using a 2.5mm Allen key holding nut "H" with a 5.5mm A/F spanner.

The arm can be moved up or down the potentiometer shaft "D" to obtain correct alignment with arm "F".

Before re-tightening ensure that potentiometer shaft "D" is turned fully anti-clockwise, then backed off clockwise 1-2 degrees with the mechanism in the end of tape [autostop] position.

This adjustment ensures that the potentiometer is operating in the correct servo range and avoids risk of causing internal damage to it.

7.5.3 End float adjustment

Incorrect end-float in the back tension bearing shaft "J" can be adjusted by releasing screw "E" using a 2.5mm Allen key taking care not to lose rotational reference between the shaft "J" and pulley "C", the correct amount of end float is between 0.002"-0.004" [0.05-0.1mm].

Should reference be lost, the correct positioning of wrap arm at limit of travel is shown in diagram.

7.5.4 End of tape (EOT) switch adjustment

The microswitch can be adjusted by carefully bending the arm "B" so that the switch operates just before the pulley reaches its end of travel [clockwise]. Ensure that the switch operates cleanly with the arm not fouling the mechanism except at the correct point of contact.

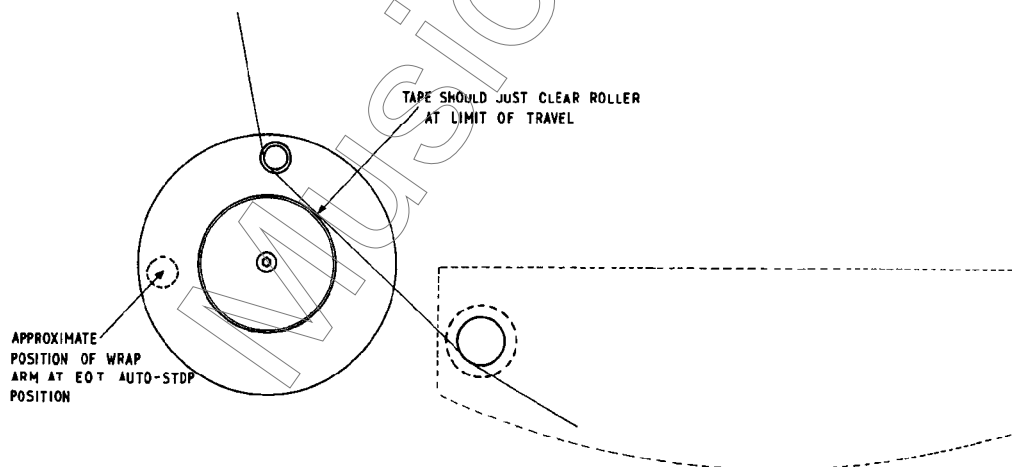

8. ELECTRICAL SUB-SYSTEMS

8.1 Audio Channel (SM8035)

The audio channel contains all the circuitry for recording and replaying signals on one track. The circuit diagram and the component layout are shown in SM8035.

8.1.1. Replay amplifier

The replay amplifier [IC7] performs the dual function of amplifying the signal from the replay head and performing frequency response corrections to obtain a "flat" output.

C55 and R109 are head matching components to obtain the best H.F. efficiency from the head. The head inductance is 80 mH. Should it be replaced with one of a different inductance these components may need adjusting.

C53 and L5 form a resonant circuit tuned to the bias frequency for maximum rejection (henceforth referred to as a bias trap).

Replay amp gain is adjusted by R98. Equalisation is achieved by C50 with R106, 104 & 99. The high frequency time constant is provided by C50 in series with R99 and R104 and low frequency [where applicable] by C50 in parallel with R106.

The output of the replay amp is taken to the monitor select system at IC4,4.

8.1.2. Sync amplifier

The sync amplifier [IC6] is a repeat of the replay amp with some circuit values modified to interface with the record head. This has a lower inductance [7mH] and a lower sensitivity which requires higher gain [R85]. The output of the sync amp is fed to the monitor select system at IC3,4.

8.1.3. Line input buffer

IC2 is a unity gain buffer for the line input signal. Input sensitivity is adjusted by R37 to a maximum of -10dBm. The output of the input buffer is fed to the monitor select system at IC3,9, and also to the record amplifier.

8.1.4. Monitor select system

a) Sync function

It is a feature of the SCM 380 series machines that the sync function switches from the sync amp to the line input signal when the channel is in "record" mode. IC4c acts as an inverter for the "REC ON" command (from IC9,4). Thus IC3c and IC3b select the source for the sync function, which is fed to the sync line output and the line output selector.

b) Line output select

IC4b and d and IC3a and d select between line input, sync and replay signals for feeding to the meter amp and line output amp. The nominal signal level at this point is -10dBm. A loaded gate (IC3d) is connected in series with the line input signal so that the signal level matches that of the sync function.

NOTE: IC3 and IC4 have a separate HT source from R39, 79, 101 and C33.

c) Selection logic

Multiplexed monitor select information arrives on edge connector pins 10 and 11 from the remote control system. This is de-multiplexed in the appropriate time slot by IC10 which uses the channel select pulse to latch up the two wire code [see sect 8.3.4]. IC8c and d decode this information into one of the four monitor states:

CODE		OUTPUT			CONDITION
Line sel	Rep sel	IC8,4	IC8,11	IC8,10	
0	0	0	0	0	MUTE
0	0	0	0	1	REPLAY
1	0	1	0	0	LINE
1	1	0	1	0	SYNC

NOTE: Logic 1 = +7v
Logic 0 = -7v

These outputs select the appropriate analogue switch in the monitor select system.

8.1.5. Metering

IC1 forms a 26dB amplifier, with 12 dB/oct. low pass filtering for additional bias rejection. R1 enables the meter to indicate OVU for an input signal of -10dB. Capacitor C2 provides a relatively slow decay time from signal peaks.

8.1.6. Line output amplifiers

The line output amplifier consists of an output level control followed by a 20dB amplifier [IC13] with a bias trap on the input. This is followed by the output driver IC15 with 12dB/oct low pass filtering after 22kHz.

IC12 and 14 are the line output amps dedicated to the sync function. This output is identical to the main line output except that R94 and 95 are of higher value to reduce the roll off frequency to 16kHz.

8.1.7. Record amplifier

The record amp IC5 has the record level control configured as an input sensitivity adjustment. The amplifier performs the dual function of driving the record head with a constant current [R45, C7] and providing record equalisation [R43, 41, 36, C16]. Maximum gain at L.F. is set by R46 and R44. Bias trap L2 and C22 prevents the output stages of the op.amp being saturated by the bias signal.

8.1.8. Erase/Bias Oscillator

The master oscillator input arrives on pins 4 and 5 of the edge connector in the form of a narrow width pulse train. [See below and sect.8.2.2]:

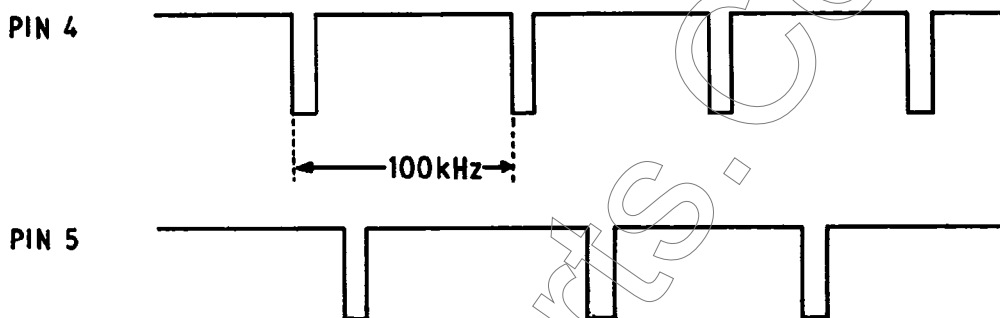

The complementary pair of TR1 and TR3 are driven into saturation by one of these pulse trains. TR2 and TR4 are switched on in antiphase by the other. The narrow pulse width ensures that heat dissipation in the drivers TR3 and TR4 is kept to a minimum. These transistors excite the transformer TX1 into resonance with C8 tuning the primary and C9 tuning the erase head to a frequency of 100kHz. RLA/1 ensures that the erase head is open circuit when the channel is not in record mode. Thus no transformer action can take place in the erase head from an adjacent track which is in record.

Bias is obtained directly from the erase head and fed to the record head via R34. C23 tunes with the record head to improve the spectral purity of the bias waveform.

Tuning: The centre slug of the oscillator transformer should be tuned for maximum output on the erase head. Required voltages are 8T 1" - 85v, 16T 1" - 40v, 16T 2" - 53v. Record head bias trap [L2] can be tuned for maximum rejection on R 48 when bias is adjusted to maximum. Other bias traps should be adjusted for minimum bias signal at the various outputs.

8.1.9. Record Selection Logic

There are three inputs to the record select system:

a) Record/Ready select is demultiplexed in its appropriate time slot by IC10 and latched (see section 8.2.1). A logic 1 on IC10,2 indicates that the channel has been selected to record/ready and allows information from the ready indicator and "record on" bus into the timing circuits.

b) Ready indication: This is a low frequency square wave, generated on the mother board assy [SM8063] and gated through to turn the LED [D7] on and off as a ready indication. When REC ON is high IC11,11 goes low and turns the LED on continuously.

c) Record On selection: Is also demultiplexed and latched at IC10 pin 10. To avoid clicks and other unpleasant side effects the process of switching a channel into record has to follow a clearly defined sequence of events. This sequence is initiated by the REC ON bus:

RECORD ON: sets IC11,11 to logic 0 and:

i) Switches sync function to monitor 'line in' [diode D9 shorts out R62].

ii) Switches RLA to record mode. RLA/1 completes erase head circuit and RLA/2 connects record head to record amplifier. Diode D8 shorts out R60 and mechanical operation time provides sufficient time delay from step 1.

iii) Initiates 'ramp on' of erase oscillator. Delay R61, C28. TR6 switches on, and TR5 off. C10 times linear current ramp through TR8.

RECORD OFF: sets IC11,11 to logic 1 and:

i) Ramps down the erase oscillator. IC9,2 overrides all time delays. TR6 switches off and TR5 turns on TR7 which discharges C7 through R25.

ii) Returns relay RLA to safe mode. Delay R60 and C25.

iii) Returns sync function to sync amp monitoring. Delay R6 and C29.

Notes on LED and relay switching:

In order to reduce interference in the audio circuits the relay and LED are driven from a constant current source, TR10 and R50. TR12 and TR11 switch off these devices by diverting the current through themselves when switched on. R55 and R89 are included as further click suppression so that the relay is not driven through its full voltage swing.

8.2. Audio Rack Mother Board (SM8063)

The mother board provides channel select pulses to the audio channels for demultiplexing the monitor select and rec/ready select remote control lines. Also included are the master oscillator, ready indicator oscillator, audio multicore and tape head terminations.

8.2.1. Control Demultiplexing

The channel clock arrives from the remote control system on the A,B,C inputs. IC2,11 generates a pulse output for every transition of the A line - as shown in the timing diagram below:

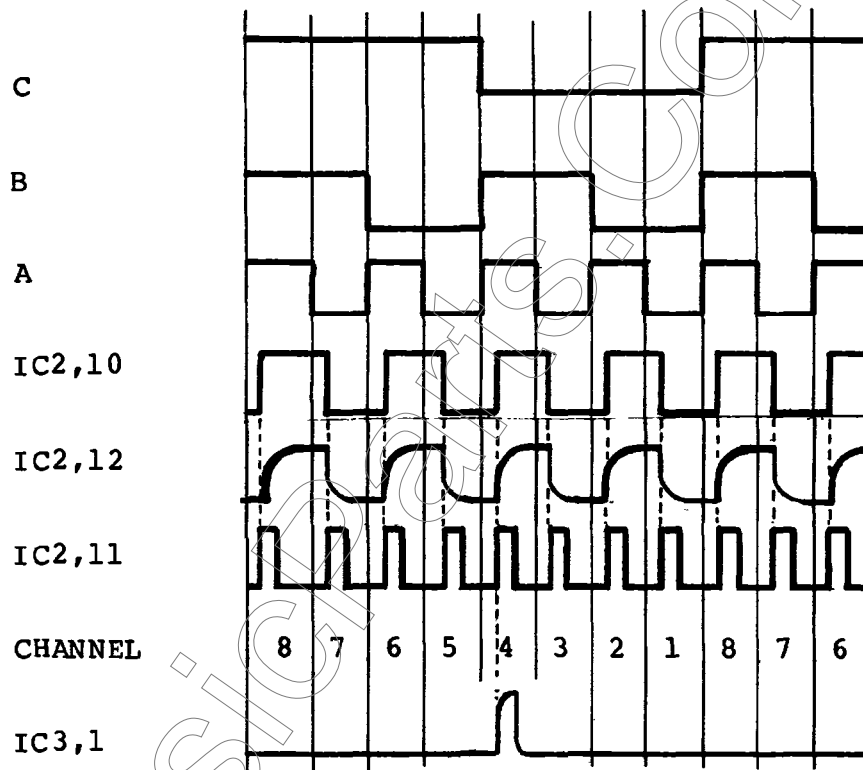

This pulse is low pass filtered by TR1, and routed to one of the eight channels by the demultiplexing chip IC3, according to the status of the ABC lines. These channel select pulses clock the monitor and rec/ready information into the appropriate channel at the appropriate time. R25-29 and C22-26 are included as low pass filters on the information buses to reduce interference in the tape head inputs.

8.2.2. Master Oscillator

It is essential in any multitrack tape recorder that the erase oscillator in the channels are in phase synchronisation with each other. If this were not the case then beating between two oscillators would produce audible signals on tape. Another requirement is that the frequency of operation should

be stable so that bias rejection circuits will stay in tune.

Both these requirements are fulfilled by the master oscillator, which feeds a crystal controlled synchronising signal to all channels. On 16 track machines, only the 1-8 rack contains a master oscillator. The 9-16 rack accepts an input to IC5 pins 1 & 2 and has the oscillator components deleted.

The crystal oscillator is formed round IC5a and is a standard CMOS feedback oscillator. The output for additional racks is taken from pin 3. This signal is a 200kHz square wave.

IC4 and IC5c and d convert the 200kHz signal into a constant pulse width pair of output signals in antiphase as shown below:

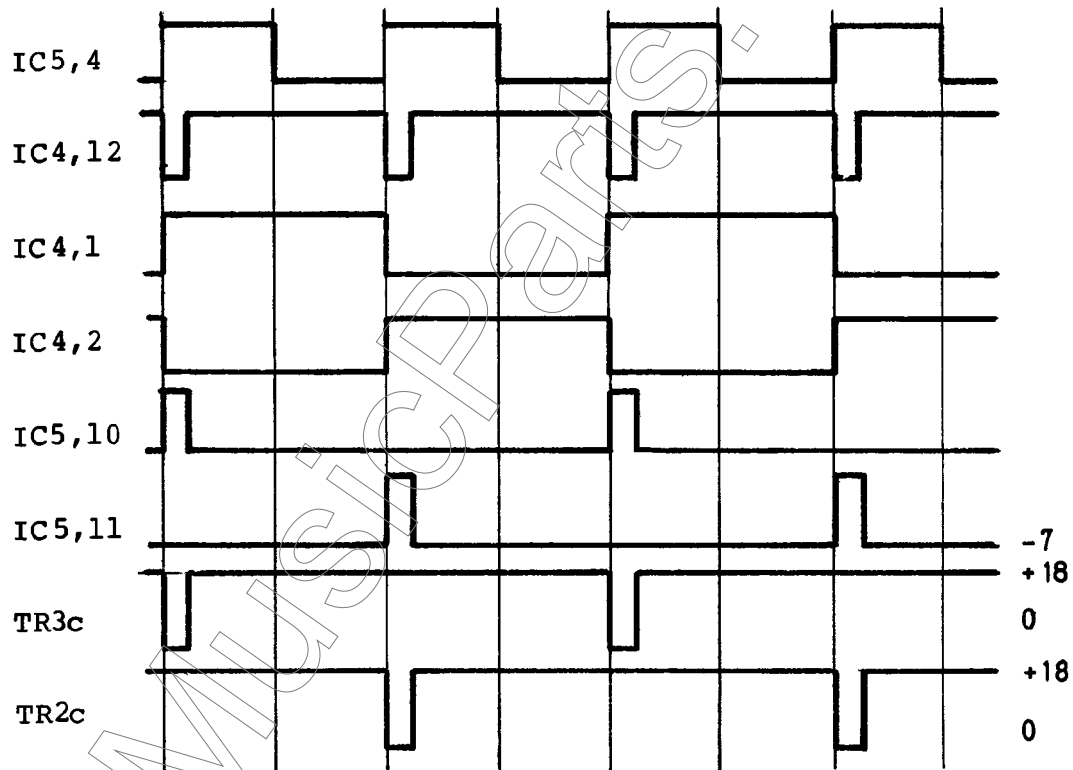

IC4b is a monostable circuit to generate a pulse at every positive transition of the input signal. IC4a acts as a divide-by-two circuit which alternately enables IC5c and IC5d, routing the pulses to TR2 and TR3 in turn. The outputs from the transistors are capacitively coupled to the bus so that a master oscillator failure will automatically switch off the input transistors in the channels thereby preventing catastrophic failure in the buffer oscillators.

8.2.3. Ready indicator

The master source of ready indication [flashing lights] is located on the mother board and is a simple two inverter [IC1c,d] CMOS oscillator. Frequency is set to approximately 1Hz by R23 and C15.

This circuit is disabled on the second rack in 16T machines.

8.2.4. Inputs and Outputs

The d.c. power comes direct from the power supply to the audio rack via PL2.

The audio multicore from the rear panel connector is terminated in four connectors [pairs of channels] on the mother board. Note that three of these connectors have only nine wires.

8.2.5. Removal and servicing

The audio rack is easily removed from the machine by unscrewing the four M6 screws at the front of the rack. Before withdrawing the rack the remote control bus and power input connector must be unplugged from the rear. Rear access is by lowering the upper rear panel of the machine.

Tape head and audio connections are hard soldered to the mother board but there is sufficient length of cable to allow the rack to be fully withdrawn and tilted downwards through 90 degrees. On reassembly into the machine, ensure that the DC power and remote connectors are inserted correctly. Also check that the audio multicore lead does not foul the cooling fan.

Note [1] On 16 track machines it is necessary to withdraw the 1-8 rack before the 9-16 rack can be removed.

Note [2] If the audio rack is being removed from the machine for other than a quick inspection, ensure that there is some support [e.g. cardboard box] for the face of the rack to rest on.

Never allow the rack to hang by audio or head cables.

8.3 Remote Control Unit [Refer SM8036/37/38/39/CD]

8.3.1. Counter & Display

Information concerning speed and direction of tape travel is received from the transport logic board via the remote control bus on pins 2 and 6. The pulse rate on pin 2 is 60Hz at 15ips, and a logic 1 [+7v] on pin 6 indicates forward direction of travel.

IC3 is a complete up/down minutes and seconds counter with multiplexed BCD and seven segment outputs. Pin 39 provides a logic 1 output whenever the counter is at zero. This is used by IC9c & d and IC12d to change the direction of count whenever the zero point is crossed. IC9 pin 11 is logic 1 whenever the count is below zero. IC7 pin 10 provides up/down count information dependant on direction of tape travel and tape position with respect to zero.

The tape position indicator is a seven segment plasma display. This unit requires a 180v HT which is provided by a straightforward astable multivibrator [TR2 & TR3] via a step-up transformer and bridge rectifier [TX1 & D3-6]. D1, via R20 and 24, provides a 30v negative potential to the "keep alive" cathodes which maintain a steady ionisation of the internal gas. The positive side of the high voltage source is tied to +7v. IC1 converts the seven segment outputs from the counter to high voltage cathode drives. R2, R3 and D2 give a programming voltage which sets the current supplied to the segments. IC2 is the anode driver using the digit outputs from the counter. Anode "off" voltage is set by the voltage drop between IC2 pins 16 and 8 (approx. 50v.)

Note: IC3 is a six digit counter of which only the upper four are displayed. The minus sign is d.c. driven and is switched at the anode.

8.3.2. Search System

The search mode operates by comparing the speed of tape travel with the tape position and providing "spool" commands appropriate to bringing the tape gradually to rest at zero.

IC's 4, 5, 6 and 7 on the counter PCB provide a voltage between +7v proportional to the distance from zero. This is done by examining the BCD data from IC3, 11-14. Any "1" present in either minutes or tens of minutes is latched by IC6 a and b respectively, to forward bias D7 whenever the tape is over 1 minute away from zero.

When the tape is less than 1 minute from zero D7 is reverse biased and IC's 5 and 7 latch an 8 bit word to a weighted resistor network which provides a voltage proportional to the distance from zero.

A voltage proportional to the speed of the tape is generated by IC10a. C10 and R11 differentiate the input

square wave to provide constant width pulses to the integrator R15, 16 and C14. The output of this circuit is compared with the position voltage, described above, by IC11. IC11 pin 1 is thus a "speed up/slow down" command. This is converted into spool left and spool right commands by gating with position plus and position minus lines [IC7a and b]. IC3 tri-states these commands when not operated [see transport logic board section 8.4.2].

The search command [remote bus 10] is latched by IC10c. IC4c resets the latch whenever "zero" is detected or on receipt of a 'stop' command.

8.3.3. Record On Selection

a) Record latch:

The record latch is formed round IC2b, and is set by the simultaneous presence of record button pressed, play mode selected [IC2,9] and play button pressed [IC2,8]. The record latch is reset by a logic '0' on IC4 pin 4. This occurs when

- :any transport command is operated, or
- :record button selected without play button, or
- :zero reached in search mode without play mode pre-selected.

N.B. Search mode selection does not cancel the record latch. If search to play is commanded while in record mode, the machine will re-enter record mode when zero is reached.

b) Record On Bus:

When set, the record latch enables IC1d to flash the record button lamp, until information that the pinch wheel is engaged is received on remote bus 4. This enables the 'record on' command to the audio channels via remote bus 21 and fully illuminates the record indicator.

8.3.4. Channel Select Clock and monitor codes

Monitor and record/ready status commands are transmitted to the machine from the remote unit in 6 wires of the remote bus by time division multiplexing. Each channel is allocated a time slot defined by the A, B, and C "channel clock" buses.

IC3a and f form a simple oscillator running at about 400Hz. IC's 1 and 2 form a binary counter to generate the channel clock buses:

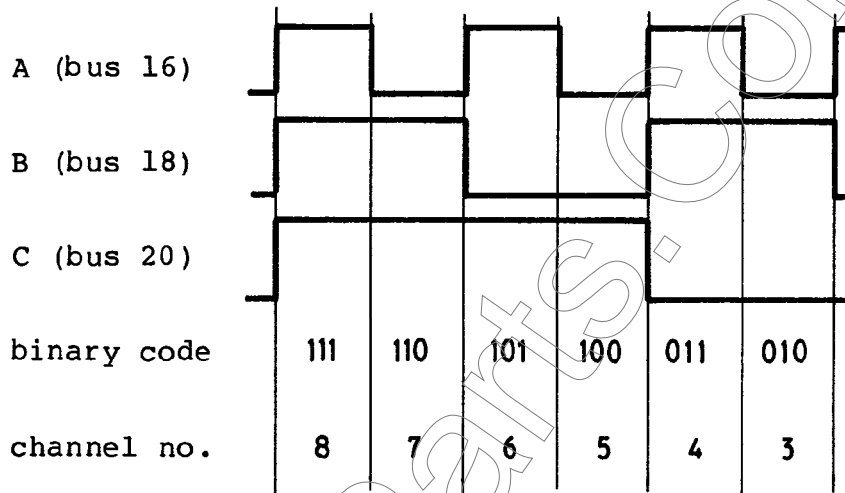

Monitor status is defined by a 2 wire code set up on the command latches IC12 a and e by the monitor mode select buttons S1, S2 and S3.

N.B. The logic levels on the command latches [IC12a and e] and the individual monitor latches IC10,11 and 12 are the inverse of the codes sent to the machine via remote bus 25 and 26.

The code as sent to the machine is as follows:

Monitor condition	rep. mon (bus 25)	line mon (bus 26)
MUTE	0	0
LINE IN	0	1
REPLAY	1	0
SYNC	1	1

8.3.5. Monitor Selection

a) Individual selection

IC16 converts an input from one of the eight monitor channel select buttons into a three wire code [similar to the channel clock code]. This is used by IC14 to route the command latch information to one of the eight pairs of individual latches. When no buttons are pressed a logic 1 on IC16,15 inhibits any further modification of the latches. IC7 scans the status of the latches in pairs according to the "channel select clock".

b) Master Selection

IC9 b & c form a toggling latch which when set [logic 1: IC9,4] inhibits the scanning of the individual latches by IC7 and opens IC8a & c to pass the monitor command latch information direct to the output.

c) Mute and Indicators

IC9a & d override all monitor selection with 00 code whenever a "mute" requirement is received from the spool commands.

IC13 decodes the channel monitor code to illuminate the LED matrix. IC9 turns on each channel's LED's in turn according to the channel select clock.

IC18 decodes the state of the monitor command latches to turn on the appropriate LED.

8.3.6. Record/Ready Selection

IC's 3, 5 and 6 form a set of 8 toggling latches operated by the record/ready switches.

IC4 scans the output of these latches according to the channel select clock, and feeds the multiplexed information to remote bus 23.

IC17 gates this information with the record on bus and the ready indicator to provide "off/flashing/on" illumination for the rec/ready LED's.

8.3.7. Disassembly

SWITCH OFF THE MACHINE

The remote control unit is simply removed from the machine or remote aux. case by undoing the two captive thumbscrews and unplugging the 25 way connector from the rear.

The unit is disassembled by removing the two screws securing the rear connector and undoing the four nuts fixing the front panel to the case. The P.C.B.'s can now be withdrawn from the case by the front panel. Unclipping the PCB guides allows the unit to be unfolded.

8.3.8. Adjustment

NOTE: HIGH VOLTAGES PRESENT INSIDE THIS UNIT

If required the control unit can be reconnected to the machine via the remote cable and power re-applied. The only adjustment in the control unit is the search mode speed detector. The procedure is as follows:

- a] Wind a tape to approximately 5 minutes away from zero.
- b] Turn preset PRL on SM8038 fully anti-clockwise.
- c] Select search mode.
- d] When the tape reaches its maximum speed turn PRL clockwise until the spool buttons just stop flickering.
- e] Observe the tape and counter as zero is approached. If overshooting occurs, the maximum speed can be reduced by turning PRL slightly anti-clockwise such that a small amount of flicker is observed at max speed.
- f] Repeat [a], [c] and [e] until satisfactory search operation is obtained.

8.3.9. Servicing hints

a] Insufficient brightness in counter display can be caused by low voltage on 24v rail. Should be 24 to 24.5 volts. Check in P.S.U. see section 8.5

b] Display segments incorrectly illuminated can be caused by too many volts on the cathode H.T. Should not exceed -190v. Adjust by increasing R6 and R7 on SM8039.

c] Machine will not count below zero: on early machines remove D3, C22 on SM8038.

d] IC1 (SM8039) overheating and/or display segments too bright: Segment current can be reduced by increasing the value of R2 to 47k.

e] Random, self-generated, changes in monitor status and inability to drop in or out of rec/ready has been known in early machines due to condensation or excessive humidity. Cure is to thoroughly dry and seal the SM8037 PCB with ignition sealer.

f] Changing monitor status on one channel when another channel is being altered. Cause: timing errors. Cure: change IC16 [SM8037].

g] Not all LEDS operating can be caused by failure of channel select clock: Examine IC1 and IC2 [SM8037]. On early machines break tracks between IC1 pins 2 and 5 and IC2 pins 2 and 5 and pins 9 and 12: reconnect with 33k series resistors.

8.3.10 Reassembly:

is the reverse procedure of disassembly. Care should be taken when clipping on the P.C. guides that they clear front panel fixings, that there is sufficient clearance between boards and that no cables are being pressed against sharp points.

MusicParts.Com

8.4. Transport Logic & Motor Drive System (refer to SM76032/CD)

8.4.1. General

The transport logic board (SM76032) accepts inputs from the transport switches, the motion sense assembly [SM76097] and the remote control unit and provides outputs to the reel motors and the deck solenoids appropriate to the current, and desired, status of the transport. Information is also provided to the remote control unit about the current transport status.

8.4.2. Command Latches

The four operating modes FF, Rew, Stop and Play are selected by the transport switches (on the deck plate or remote control unit) by momentarily applying +7v to the appropriate buses. The switches are wired in series, to assign priority and prevent two commands being entered at once.

IC4 contains the four feedback "command latches" which are set by the switches.

IC12 combines various inputs to reset the latches.

8.4.3. Spool function

a) Spool left: The output of the command latch is fed via a slight delay [D21, R92, C54] to the reset input of the spool left function latch. Thus IC7 pin 13 goes to logic 0. The inverted output (pin 12) is sent to the motor control circuit. The spool function latch is cancelled by a logic 1 from IC15,11.

b) Spool right: is identical in operation to spool left.

8.4.4. Motion sensing (See also 8.6)

The output from the motion sense assembly is examined by IC10 and the phase relationship between the two pulse trains provides a logic 1 on IC10 pin 1 for forward travel and a logic 0 for reverse travel.

IC17 pin 7 is a monostable output which goes to logic 1 when the tape is travelling slower than a predetermined speed. This is used by the play and stop functions to indicate that dynamic braking can be terminated (IC9 pin 3) and that mechanical braking can be applied or the play function latch set.

8.4.5. Dynamic braking

Whenever a stop or play command is detected by IC1,11, a pulse is generated by C38 and R102. This provides the equivalent of a spool command to the spool function latches via IC18a and b and IC15a and b, appropriate to the current direction of tape travel. When the motion sensing indicates that tape has come to rest, IC9,3 provides a logic 1 to deactivate the spool function latches.

8.4.6. Play Function

a) The output of the play command latch is fed to IC9,9 and when no motion is indicated by IC17,7 a clock signal is provided to set the play function latch, IC10b.

The output of the play function latch generates a "play start" command to the motor control system.

b) This output also enables the "play speed detector" [PSD] circuit, see section 8.4.10 below.

c) This condition results in:

- [i] operation of the pinch solenoid
- [ii] removal of "play start" tension
- [iii] application of play tension
- [iv] remote bus 4 [pinch] activated.

8.4.7. Play speed detector

a) Circuit Description

Motion sense pulses are sent to a monostable at IC17 pin 12 which provides constant width pulses to the integrating diode and capacitor (D22, C56).

The width of these pulses is reduced by TR21 which is switched by the speed change logic bus. Thus, for HI speed selection, a greater pulse repetition frequency is required for the same integrator output voltage.

The integrator output voltage is compared by IC16 to the capstan control voltage, as amplified at IC16 pin 1. Thus IC16 pin 7 switches from LO to HI when tape speed is approximately equal to the capstan rotation rate.

When 'play' mode is selected, this signal is used to operate the pinch wheel, thus if motion sense information is lost then the pinch wheel disengages. This feature can be overridden by connecting a 100k resistor between pins 8 and 10 of IC5. This has the effect of latching the pinch signal.

b) Model differences

The first machines fitted with this logic board had the variable PSD facility disabled since the appropriate logic signals were not provided by the early noise reduction interface boards (SM 16066). This has been achieved by connecting the capstan control input (pin 26) to 0v and the speed change input (pin 25) to +7v. Under these circumstances the PSD has a fixed setting and should be readjusted when changing speed.

SCM 381-8 eight track recorders do not have a speed change facility and this line is connected to +7v. However, the capstan control voltage can be hard wired to the logic board from the transport termination board. This has been done on a number of machines. (See drg. no. SM38030)

c) Adjustment

The variable PSD system should not require adjustment. However, if necessary, the system can be set up as below:

- 1) Connect oscilloscope to IC5 pin 10.
- 2) Set machine to "play".
- 3) Set PSD preset fully counter-clockwise (as viewed from component side).
- 4) Increase preset setting until negative going pulses can be seen on the oscilloscope. Back off the preset so that these pulses disappear.
- 5) Check that pinch operation is smooth for all settings of the speed change switch and the varispeed controls. If necessary repeat step 4.

N.B.

Failure to put all channels into "Record" can result from incorrect PSD setting since the record system is linked to the "Pinch" signal.

8.4.8. Stop Function

The stop command only activates the dynamic braking system. There is no stop function latch. The stop function is defined as the absence of any other function and when detected by IC9 pin4, provides a stop tension signal to the motor control system and applies the parking brakes.

8.4.9 Autostop [EOT or End of Tape]

A microswitch is attached to the tension control arm [see SM8088] which is operated when no tape is present on the machine. This is used to:

- a) Switch off motor power - TR1 & TR2 short out drive signal
- b) Force command latches to stop mode - TR18
- c) Apply mechanical braking - TR3 removes power from brake solenoids.
- d) Switch off Dump Edit facility - TR19

8.4.10. Edit

Edit mode is controlled by a toggling latch formed round IC3c & d. When set [logic 1 on IC3,10], fixed tension is applied via the motor control system and the brakes and tape lift pins are defeated [IC14,6 & IC9,12].

A logic 1 on IC3,12 enables the latch in stop function only.

8.4.11 Dump Edit

When the machine is selected to "Edit" and the play button is pressed, a logic 1 is generated on IC8 pin 10. This logic signal activates a number of effects:

- 1) Cancel edit tension (IC13 pin 9)
- 2) Operate pinch wheel (IC 6 pin 9)
- 3) Set play tension (IC 6 pin 10)
- 4) Cancel stop tension (IC13 pin 6)
- 5) Cancel take up motor play tension (TR15)

This signal is also taken via a time delay (R86, C45) to IC5 pin 6 which enables the "stop" command to reset the "edit" latch at IC3,12.

Auto stop also cancels the "edit" function via C24.

8.4.12 Motor Control System

a) Circuit Description

A block diagram of the motor control system is shown below:

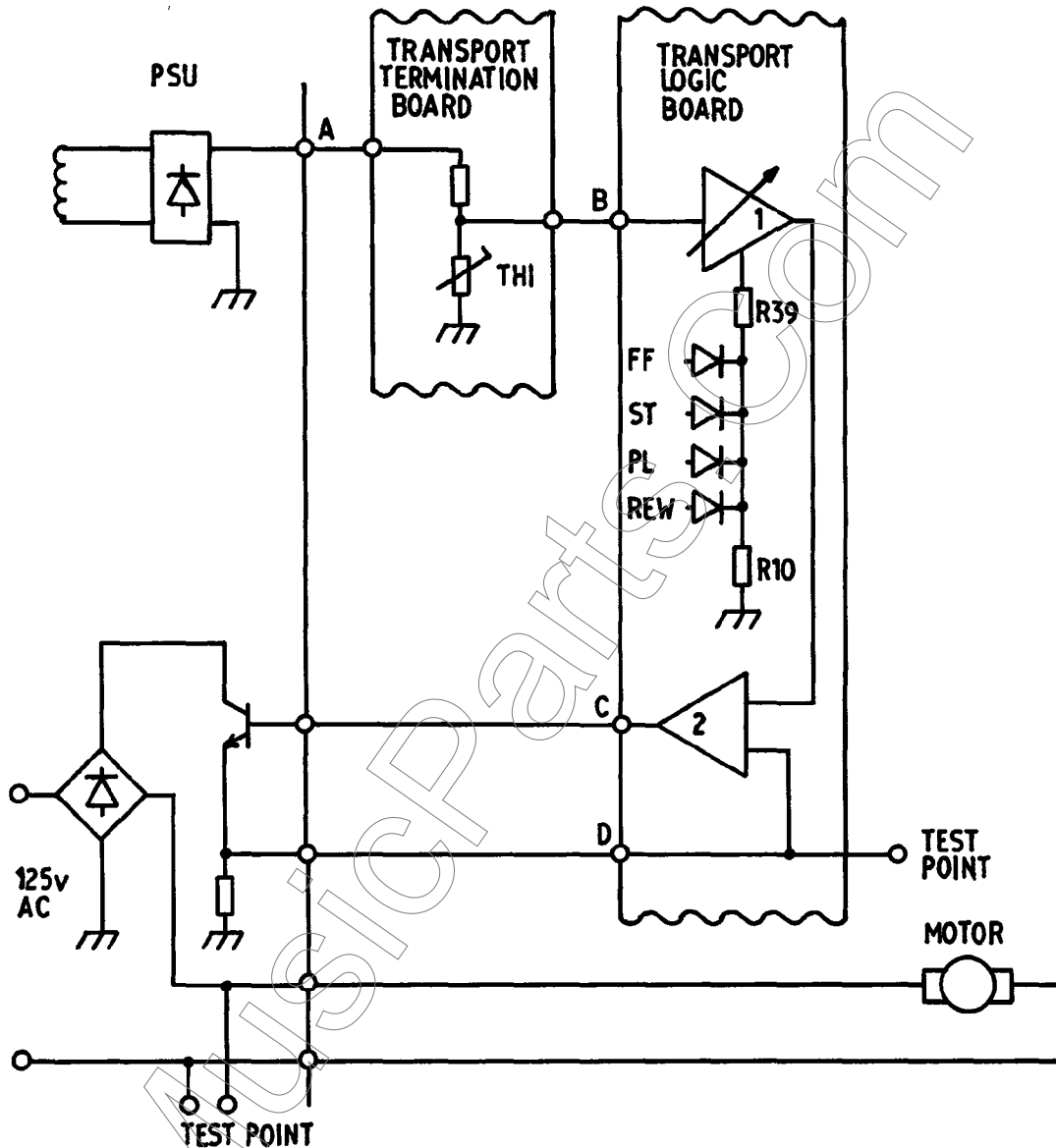

A full wave rectified signal is produced in the PSU assembly and is fed to the transport termination board where a thermistor circuit provides a constant output voltage (B) to the gain controlled amplifier on the logic board (IC1). The gain of this amplifier is set by the outputs of the logic system described above which generates a control voltage across R10. This is converted to a current by R39. R39 and the logic inputs are fitted with select on test resistors for setting motor tensions under the various operating modes.

The output of IC1 is buffered by IC2 and the resultant signal (C) is fed to the power transistors in the PSU assembly. These are connected across a bridge rectifier which is wired in series with the motor itself.

Current sensing feedback is taken from the emitter of the power device to the buffer amplifier IC2. An offset adjustment preset is provided on the input to IC1 to set the correct d.c. level on the logic board test point.

Test points are also provided on the rear of the PSU assembly for measurement of the voltage being supplied to the motor.

b) Adjustment procedure.

The only user adjustments provided are for play tension and amplifier offset. These should only be adjusted in the event of obvious changes in performance:

a) Check that machine responds to the transport control switches and that the tape counter is operational.

b) Check that all test equipment is NOT EARTHED at the mains. Select A.C. voltmeter to read 200V AC.

c) Connect AC voltmeter to Take Up motor test point on the PSU. Note that these test points are fitted with "divide by 10" networks.

d) Connect scope to Take Up motor test point on the logic board itself. (See SM76032).

e) Select 'Edit' and adjust the offset preset (PR1 on Logic Board SM76032) such that the points of the oscilloscope display are at 0V. (see sketch).

WRONG



RIGHT



WRONG



8.5. Power Supply/Trolley Unit (SM 76018)

8.5.1 General

The trolley/PSU assembly is a self contained assembly and provides all the regulators for the d.c. power in the recorder

Also included in the unit are all the a.c. reel motor power drive components.

Power is supplied to the recorder via two ten way cables.

8.5.2. Circuit Description

a) All the d.c. rails are fitted with integrated regulators and adjustment presets for setting output voltage.

Each rail is fitted with fuse protection on the input to the regulator.

b) +9v is sent to the recorder unregulated. This is used for providing locally regulated supplies at various points in the machine:

(i) +5v regulator on the transport termination board (see SM 76032/CD and SM 76081) this supplies +5v to the capstan motor and to the remote control bus.

(ii) +5v regulator in the remote control (with autolocator), on the computer board.

(iii) +6v regulator in both remote control units for supplying local HT to LED's and displays.

(iv) The unregulated supply is available on the remote control bus for limited use by external interface systems.

c) +32v. is used by the capstan motor only.

d) The motor control output is taken from the 32v. secondary winding on the power transformer. This is a full wave rectified signal.

e) An outline block diagram of the motor control system is shown in section 8.4.12. Taking the feed motor circuitry:

The drive signal from the logic board is received on pin 6 of the power cable and fed to the pre-driver TR1, which is connected in a darlington configuration with the two parallel power drivers. Emitter feedback is returned to the logic board from one of these devices. Thus the current through the power drivers is proportional to the drive signal voltage.

The power drivers are connected across the D.C. side of bridge rectifier BR1, and constitute a control element to the current flowing through it.

The bridge is connected in series with the transformer winding, protection fuse FS2, and the reel motor itself.

The phase lead capacitor for the motor windings is

also located in the power supply assembly.

8.5.3. 8 Track PSU Assembly (see SM38018)

a) Current 8 track recorders have the motor power drive system contained in the power supply assembly and use the same PCB as the 2 inch 762 recorders.

b) 32v d.c. is not required by the capstan motor and thus pins 1 and 3 of the d.c. cable are connected together.

c) The motor drive system is only fitted with one power transistor and a pre driver transistor is not required.

d) Otherwise the system is as described above.

8.5.4. Servicing

WARNING DO NOT REMOVE ANY PANELS WITHOUT FIRST DISCONNECTING THE MAINS INPUT

a) Access to the motor power transistors can be gained by removing the right hand wooden side cheek on the trolley assembly.

The transistors associated with the feed motor are towards the front panel of the unit and those for the take up motor are to the rear.

If any of these transistors require replacement ensure that adequate heat sink compound is applied.

b) Any further access to the unit requires that the recorder unit is detached from the trolley unit.

(i) Remove both wooden side panels from the trolley unit.

(ii) Undo the four screws securing the recorder to the trolley unit. A 5mm AF hex key is required.

(iii) Detach the two 10 way power cables from the recorder and lift the recorder away from the trolley unit.

(iv) To gain access to the PCB assembly, undo the self tapping screws securing the lid.

c) To gain access to the underside of the PCB, detach the two connectors from the front panel wiring. Undo the two screws securing the IC regulator sub heatsink to the main heatsink. Undo the three screws securing the PCB assembly to the base of the trolley unit.

The PCB assembly can then be lifted up at the front, complete with the IC regulator heatsink.

d) Some units are fitted with a.c. fans and if this should require disconnection from the PCB termination ensure that it is reconnected to the same pins.

8.6. Motion Sensing (see SM76097)

The motion sense board assembly is mounted directly under the roller and is fitted with two opto interruptors whose light beams are broken by the motion sense disc.

Taking one side of the circuit:

The output from interruptor A is amplified and squared by comparator IC1. The +7v logic signal on IC1, 14 is then sent to the motion sense inputs of the logic board.

R12 and C4 act as a low pass filter and the voltage fed to IC2, 10 is proportional to the mark space ratio of the output waveform.

This voltage is amplified and inverted at IC2 pin 7, and is then used by TR4 to control the amount of current in the emitter of opto switch A.

A logic signal ("spool gate") is received on pin 6 of the connector which goes to logic 1 (+7v) when neither spool mode is operating. TR3 is turned on which disables the automatic control of opto switch current, by grounding C4 via TR2. This prevents oscillation of the system when the tape is stopped, or moving at low speed.

8.7. Noise Reduction Interface (SM 76066)

Recorders supplied with the N option are fitted with a connector on the lower rear panel which provides outputs for switching non simultaneous noise reduction units (e.g. Dolby M16)

The decoding logic is located on the Noise Reduction Interface board.

8.7.1. Conditions

Each track of noise reduction is enabled in the following modes:

- a) Line in monitor
- or b) Sync monitor AND rec/ready AND not play
- or c) Record

Recorders without the N option still use condition (b) to select line input monitoring.

N.B. When used with an in-line console, this feature can cause feedback in the monitoring system. If necessary it can be defeated by disconnecting:

IC1,13 from IC2,3 and:
IC1,9 from IC2,4

and connecting:

IC1,9&13 to -7v (logic 0).

8.7.2. Command Generation

Remote control via PLL is distributed to the audio racks and the internal remote bus, the monitor status having been modified as described above.

Considering the 9-16 section:

IC2,10 detects SYNC
IC5,10 detects SYNC and READY
IC2,4 detects SYNC and READY and PINCH
IC1,10 inverts the REP MON bus if this condition is true, (see monitor codes, sect 8.3.4) thus generating "line in" monitor condition
IC1,4 detects "line in" monitor condition
IC5,4 detects record status

Thus IC4,10 sends multiplexed "noise reduction enable" information to the demux and latch system.

8.7.3. Demultiplex and Latch

The multiplexed command information is fed to the three demultiplexing chips IC7,8&9. Considering the 1 to 8 rack, IC7 routes the input signal to one of eight feedback latches according to the channel select clock. IC3 generates a strobe pulse (similar to that on the audio rack mother board-sect8.2.1) to prevent timing errors between adjacent time slots. The latch switches on the open collector output transistors, which can sink up to 20mA from the 24V rail (supplied to connector pin 25). Internal pull up resistors are provided on each output to enable high impedance, voltage sensitive inputs to be driven.

8.7.4. Speed Adjustment

A relay is provided, driven from the speed change command (where fitted), to select between two adjustment presets. Both speeds should be set using a frequency counter and a test tape.

N.B. Only capstan speed is affected by this command. No switching of equalisation is provided.

See also Capstan / Varispeed sect 8.8.

8.8. Capstan Control System

A block diagram showing the routing layout of the capstan servo control system of various types of machine is shown opposite. For detailed wiring information refer to the appropriate wiring diagram:

8 track	-	SM38030
early 762	-	SM76030/1
later 762	-	SM76030/2

Notes:

1. 8 Track machines

The capstan control system is wired on a separate cable using a 4 PIN DIN connector. Pin 3 on each of the din connectors in the system are connected together and left open circuit in the recorder (see 18.4 - External Control).

2. Early 762 Recorders

Speed switching is accomplished by switching the fixed speed control line between two preset resistors situated with the switching relay on the noise reduction interface board (SM38066). The capstan servo board is hard wired to a single selection, giving a varispeed range of 12 to 33 ips.

3. Later 762 Recorders

Facility is provided on the noise reduction interface board (SM76066) for selecting two speed ranges on the capstan servo board. Two settings of varispeed range are thus provided:

LO SPEED	-	6 to 17 ips
HI SPEED	-	12 to 33 ips

See 18.4 (External control) for volts vs. speed characteristics of these two ranges.

1. 8 TRACK

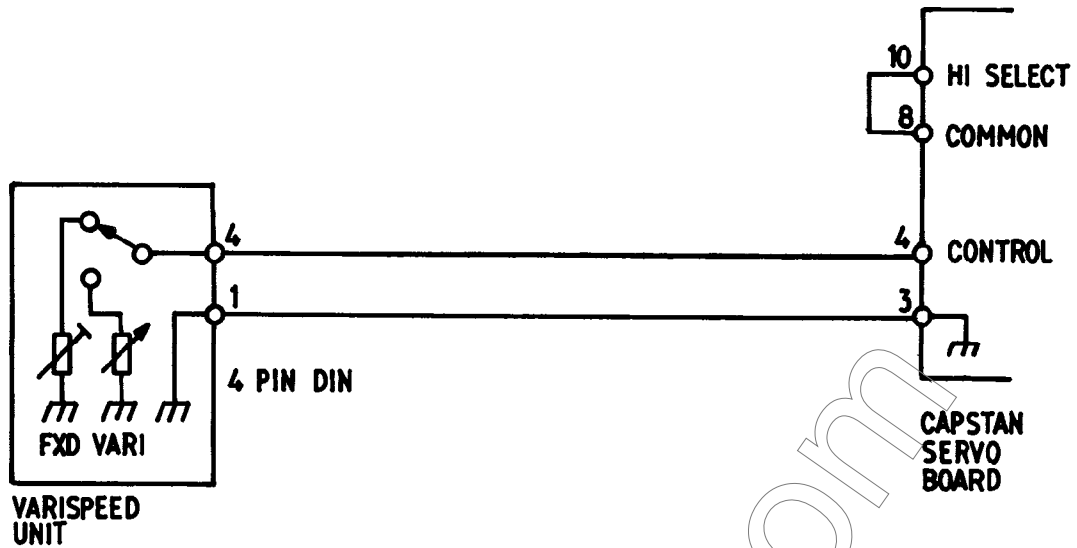

2. EARLY 762 RECORDERS

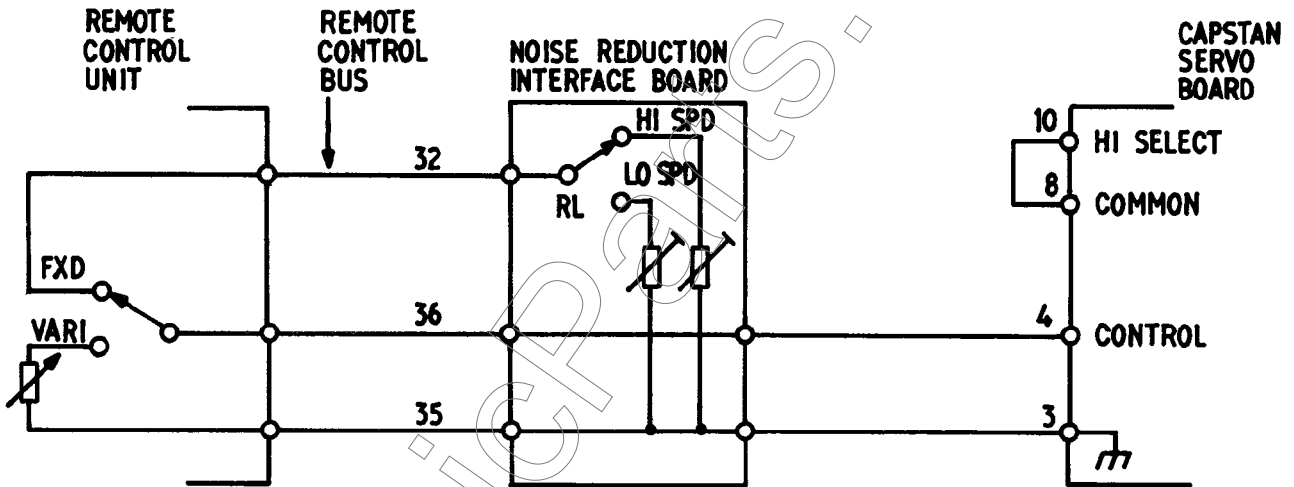

3. LATER 762 RECORDERS

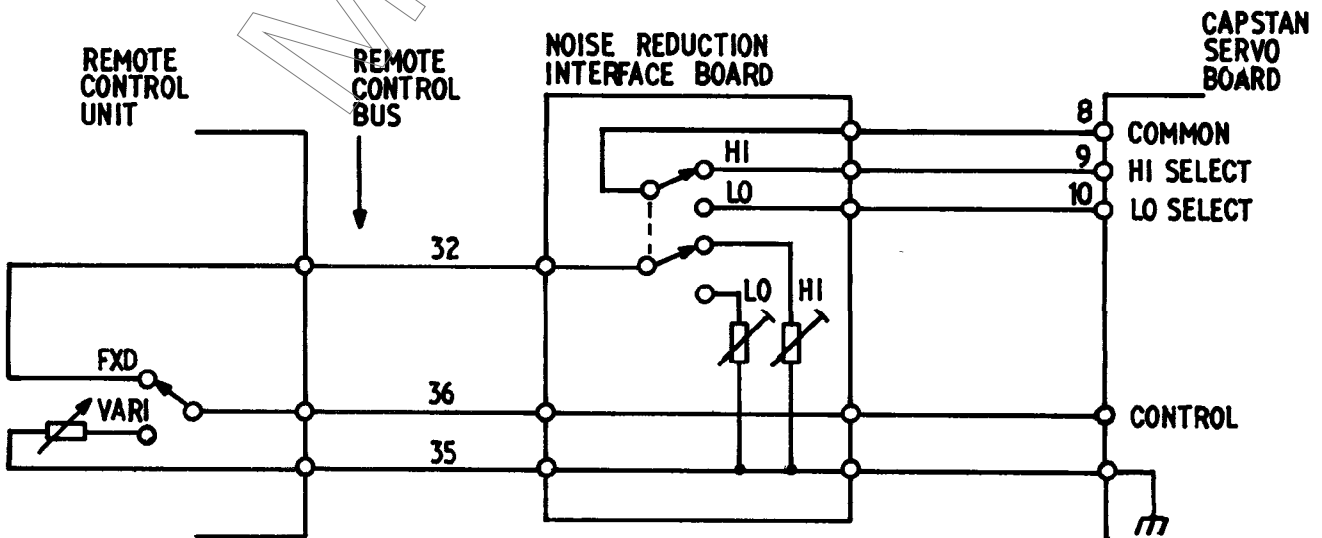

8.9 Remote Control Bus - Summary

8.9.1 General

The remote control bus is a standardised bus arrangement throughout the SCM 380 range of machines.

ALL REFERENCE TO REMOTE CONTROL BUS NUMBERS IS IN TERMS OF WIRE NUMBERS IN THE FLAT CABLE USED TO IMPLEMENT THE SYSTEM.

a) 8 Track machines only use the first 26 wires in the bus and it is WIRE NO.1 that is missing in the 25 way D-type external connector.

b) Brief designations and a pin list (including standard D-Type pin numbers) are shown on the Noise Reduction Interface board layout SM76066. Function descriptions are given below.

8.9.2 Transport Functions

<u>Bus No.</u>	<u>Designation</u>	<u>Remarks</u>
2	SPEED	+7v square wave output from transport logic board: Frequency proportional to speed of tape travel: 60Hz=38cm/s
4	PINCH	+7v: +7v. indicates pinch roller engaged with the tape: 'Record' mode cannot be entered without this flag. Can be used to indicate 'Play' mode engaged.
6	DIRECTION	+7v: +7v. indicates tape moving from left to right
5	SP. LEFT	+7v: Transport command inputs and flags:
7	STOP	High impedance bus: <u>Momentary</u>
8	SP. RIGHT	application of +7v. sets latches: +7v.
9	PLAY	on bus indicates "command" latch set
10	SEARCH	(not mode engaged). See section 8.4.2 and drg. SM76032.

Note that the search bus is only used in machines supplied with remotes containing a "Search" button. Otherwise this bus may be used to prevent the recorder responding to a play command until the bus is released to -7v.

8.9.3 Power rails (see also section 8.5)

3	+24v.	Solenoids, lamps, relays
11	-18v	Audio, Logic (-7v.)
12		
13	+18v.	Audio, Logic (+7v.)
14		
15	0 (18)	0v. for audio and logic rails

17	0 (24)	0v. for +24v, +5v, +9v
19		
22	+5v.	Capstan Motor, LED's
34	+9v.	Unregulated supply for remote control unit regulators.

8.9.4 Audio Functions

1	D	Channel Select Clock (see section 8.3.4): 8-4-2-1 code generated in remote control unit: Indicates which one of 16 channels is addressed: +7v. logic: D line not present on 8T machines
16	A	
18	B	
20	C	
23	READY BUS (1-8,17-24)	
25	REP BUS (1-8,17-24)	Multiplexed command information: +7v. logic:
26	LINE BUS (1-8,17-24)	Routed by channel select clock to indicated channel nos. (see sections 8.3.4- 8.3.6)
27	LINE BUS (9-16,25-32)	
28	REP BUS (9-16,25-32)	
30	READY BUS (9-16,25-32)	
29	REC BUS (9-16,25-32)	
31	REC BUS (1-8,17-24)	
21	REC ON	+7v logic flag. Logic 1 indicates "record" mode
24	READY INDICATOR	+7v square wave output from the mother board (approx 0.5 Hz)

8.9.5 Capstan Control (see sections 8.7.4 and 8.8)

32	V°SPD (Fxd)	Connected to V°SPD (ctrl) for 38cm/s
36	V°SPD (Ctrl)	Input port for speed control
33	SPEED CHANGE	+7v. logic: Switches V°Spd (Fxd) between two preset values: +7v.= LO SPEED (not fitted on early machines)
35	V°SPD (0v.)	Separate return wire for capstan control
37	V°SPD (Ext)	Port for the injection of external voltage control sources for capstan speed. Should be referred to bus 35. (See section 8.10. External control)

On 8T machines the DIN connector contains V°SPD (Ctrl), V°SPD (Ext) and V°SPD (0)v. only - see drg. SM8033/CD.

10. Users Fault Finding Guide

The following is a list of common complaints and their cures. It is by no means intended as a comprehensive list and if suggested cures fail to rectify the problem it should be referred to a competent service engineer, preferably the Soundcraft dealer from whom the equipment was purchased.

<u>Fault</u>	<u>Suggested cause</u>	<u>Cure</u>
Hum on the line outputs		
a) In all monitor states	Incorrect earthing	Check that machine is only earthed via mixing console OR its own PSU
b) In line in monitor only	Bad earthing of mixer or ancilliary equipment	
c) In sync and replay monitor only	Head shield not inserted	Insert head shield
	Undue proximity to magnetic fields	Relocate machine or nearby mains powered equipment or machine PSU
Insufficient H.F. Response	Dirt on heads	Clean recording heads with a non-abrasive applicator (such as a cotton bud) lubricated with a proprietary head cleaning fluid.
	Machine incorrectly biased or equalised for the tape in use	Realign machine according to section 5.5
	Incorrect head adjustment	Adjust heads according to section 5.4
Complete loss of audio signal	faulty connectors	Check insertion and wiring of audio leads and connectors
Complete failure of wind motors	faulty connectors	check insertion of AC power leads and connection to PSU
	auto stop (EOT) activated	tighten tape path manually
Intermittent or incorrect operation of remote control	faulty connectors	check insertion of remote cable connectors.

Total machine failure	fuse failure	replace fuse with one of correct type.
Tape path distortion	incorrect tape tension	adjust reel motors according to section 6.1.
Failure to enter play mode at end of reel	Incorrect tape path	Refer to section 3.3 or fig. 3
Excessive sluggishness in wind modes	incorrect tape tension	check PSU voltage tap settings adjust reel motors according to section 6.1.
Excessive wow and flutter	incorrect pinch pressure	refer to section 7.1
	incorrect tape tension	adjust reel motors to section 6.1.
Excessive speed drift	incorrect pinch pressure	Refer to section 7.1
	incorrect tape tension	adjust reel motors to section 6.1.
Excessive vibration in wind modes	Spool retainers not fully tightened	Tighten
	Reels not properly centralised	Use reels of correct I.D. OR re-locate centralising ring see section 3.2.
Tape scrapes against reel flanges	Incorrect spool carrier height adjustment	Adjust according to section 3.4.
Machine does not reliably enter 'record' mode	Incorrect operation of controls	Ensure that 'record' button is released before 'play' button -see section 4.6.

For more detailed servicing information refer to sections 7 and 8

11. Test Result Summary

The Soundcraft Magnetics SCM 381-8 undergoes a rigorous test schedule at the end of the assembly procedure, covering all aspects of machine performance. This is followed by an extensive soak test during which the machine is cycled through all its operating modes. After this a check is carried out on major machine functions.

The results of this pre delivery test are shown below.

Notes on the pre-delivery tests:

11.1. Noise

All measurements are conducted with the machine aligned as described in section 5.1

The measurements are direct readings of output level in a 100 kHz bandwidth, and thus 8dB should be added to the measurement figure to obtain the S/N ratio referred to 510 nWb/m.

The first row of measurements indicates the residual noise of the machine alone.

The second shows the noise output with new, unrecorded tape being passed across the heads.

The third indicates the output level after recording a length of tape with no input signal, rewinding and replaying the result

11.2. Signal Handling

11.2.1. Distortion

A length of tape is recorded with a 400 Hz tone at 320 nWb/m. The result is the distortion measured when the tape is rewound and replayed.

A channel is selected at random and the signal output level at which 3% distortion occurs is noted

11.2.2. Frequency response

Another channel is selected at random and a number of tones recorded at 20 dB below 320 nWb/m. The replayed output levels are noted with respect to the 1kHz level.

11.3. Tape Handling

11.3.1. Speed drift

A 3kHz tone is recorded at the beginning of a reel of tape. The tape is removed, turned over and replayed (i.e. now at the end of the reel). The percentage deviation in frequency is noted

11.3.2. Wow and Flutter

Total wow and flutter to DIN weighting is noted.

11.3.3. Position accuracy

The position of the tape with respect to some

fixed point (e.g. head block exit guide) is marked and the tape position indicator reset. The tape is wound forward 10 minutes and 'search' mode activated. The error in tape position when the tape comes to rest is noted.

11.3.4. Motor Voltages

The voltage on each reel motor in all operating modes is recorded for information only.

MusicParts.Com

Glossary

dBv :	dB's with respect to 775mV rms
PSU :	Power supply unit
HF :	high frequency (above 3kHz)
ID :	inside diameter
nWb/m :	nanoWebers per metre (Unit of magnetic flux)
EOT :	end of tape
drop in :	commence recording
drop out(1) :	cease recording
drop out (2) :	intermittent loss of HF response
bias :	high frequency signal superimposed on the recorded signal to obtain the best distortion and noise performance from magnetic tape
sync :	replaying the tape using the record head. Sometimes referred to as synchronous reproduce, sel sync or self synchronisation.

13. SOUND CRAFT RECOMMENDED WARRANTY

(This warranty applies to sales within the U.K. and should form the basis of the warranty offered by any vendor wherever situate of Soundcraft products).

13.1

- "Soundcraft" means Soundcraft Magnetics Ltd.
- "End User" means the person who first puts the equipment into regular use.
- "Dealer" means the person other than Soundcraft (if any) from whom the End User purchased the Equipment provided such person is authorised by Soundcraft or its accredited Distributor.
- "Equipment" means the product supplied with or referred to by this manual.

13.2 If within the twelve month period from the date of delivery of the Equipment to the End User (or 15 months from the date of despatch from Soundcraft - whichever is the sooner) it shall prove defective by reason only of faulty materials and/or workmanship (but not faulty design) to such an extent that the effectiveness and/or usability thereof is materially affected the Equipment or the defective component should be returned to the Dealer or to Soundcraft and subject to the following conditions the Dealer or Soundcraft will repair or at its option replace the defective components. Any components replaced will become the property of Soundcraft.

13.3 Any Equipment or component returned will be at the risk of the End User whilst in transit (both to and from the Dealer or Soundcraft) and carriage or postage must be prepaid.

- 13.4 This Warranty shall only be available if:-
- (i) the Equipment has been properly installed in accordance with instructions contained in this manual; and
 - (ii) the End User has notified Soundcraft or the Dealer within 14 days of the defect appearing; and
 - (iii) no persons other than the authorised representatives of Soundcraft or the Dealer have effected any replacement of parts maintenance adjustments or repairs to the Equipment; and
 - (iv) the End User has used the Equipment only for such purposes as Soundcraft recommends, with only such operating supplies as meet Soundcraft specifications and otherwise in all respects in accordance with Soundcraft's recommendations.
- 13.5 Defects arising as a result of the following are not covered by this Warranty: faulty or negligent handling, chemical or electro-chemical or electrical influences, accidental damage, Acts of God, neglect, deficiency in electrical power, air conditioning or humidity control.
- 13.6 The benefit of this Warranty may not be assigned by the End User.
- 13.7 End Users who are consumers should note that their rights under this Warranty are in addition to and do not affect any other rights to which they may be entitled against the seller of the Equipment.

14. SPECIFICATIONS

Model	SCM 381-8	SCM 761-16	SCM 762-16	SCM 762-24	
Format	8T 1"	16T 1"	16T 2"	24T 2"	
Reel size	10.5	10.5	10.5	10.5	inches
Speed	38.1	38/76	38/76	38/76	cm/sec
Varispeed	+15,-50	+10,-50	+10,-50	+10,-50	%
Speed stability	0.1	0.1	0.1	0.1	%
Wow + Flutter	0.03	0.03	0.04	0.04	%
Start time	0.5	0.5	0.5	0.5	sec
Wind time (700m)	100	100	100	100	sec
Power requirement	500	550	550	600	VA
Voltage req ^u ment	100/120/220/240 +10% All models				
Rec/rep freq resp	+1,-2	+1,-2	+1,-2	+1,-2	dB 40-20kHz 15 i.p.s
Rec/snc freq resp	+1,-2	+1,-2	+1,-2	+1,-2	dB 100-20kHz 15 i.p.s.
Rec/rep S/N	63	60	63	60	dB
Rec/rep Xtalk 1kHz	-55	-44	-55	-55	dB
Rec/snc Xtalk 1kHz	-24	-14	-24	-18	dB
Bias freq.	100	100	100	100	kHz
I/P sensitivity	-10 to +20 dBm, 10k input impedance				
Output level	-10 to +10 dBm @ 0VU, +22dBm max @ 600R				
Line o/p bandwidth (inc. sync mode)	22	22	22	22	kHz
Sync line o/p b/w	16	16	16	16	kHz
Audio connectors	1/4" Jack + D-type :: D-type/Varelco multiway				
Dimensions	55*52*102	55*52*102	55*52*102	55*52*102	cm
Weight	45	53	55	65	kg
Temperature	10°C to 30°C				
Humidity	less than 85%				

17. OPERATIONAL CONTROLS

SCM 760 Series Additional Information

17.1 General

There are some features which 16 and 24 Track Recorders have in common with the 8 track remote as described in Section 4.

(i) Standard Remote :

Counter and search to zero - section 4.3

(ii) Autolocator remote :

Mute defeat - section 4.4

Monitor selection - section 4.5

17.2 Monitor Status

There are two modes of operating the monitor system.

17.2.1 Mute defeat (indicator on)

In this condition, selecting one of the three monitor mode select buttons switches all tracks to the selected mode. The line output amplifiers are permanently connected to the appropriate signal in all operating modes.

An exception to this is incorporated in the "sync" mode where certain automatic switching takes place:

While monitoring sync:

a) When the machine is not in play, any track not selected to "ready" switches to line input monitoring. This allows an overdub track to be cued for level and eq. adjustment without having to switch the entire machine to "input" monitor.

b) Putting the recorder into "play" reverts all tracks to sync amplifier monitoring.

c) Any channel then selected to "Record" will automatically switch back to "input" monitoring.

17.2.2. Auto mute (mute defeat indicator off)

In this condition further automatic switching is provided in the monitor system.

a) Replay mode

When in replay monitor mode all tracks are muted except when the pinch wheel is engaged with the capstan. This prevents high frequency chatter being transmitted to the monitor speakers when winding tape at high speed, and provides a clean start to music signals when entering play mode, without the initial acceleration to play speed. This condition is signalled by a flashing "replay" indicator.

b) Sync mode

The sync amplifiers are disconnected from the output amplifiers in all the same conditions as for replay muting. The outputs are fed with "line input" signals rather than being muted. This condition is signalled by a steady sync indicator and a flashing line input indicator.

Automatic switching to "input" is still provided on individual tracks selected to "Record"

c) Line input mode

is unaffected by the auto muting system.

17.2.3. Time code track

A facility is provided internally to select one track to be unaffected by the muting system (see section 18.2.1. (b)). This enables the machine to be used in all modes with a time code synchroniser which requires the presence of time code during fast wind operations.

NB It is inadvisable to use sync monitoring while recording a track adjacent to a time code track. Use replay monitoring and set the appropriate time offsets into the synchroniser system.

17.3. Cycle Function

A cycle function is included to enable repeated plays of a particular section of tape. This is operated as follows:

- a) At the beginning of the passage of interest set the counter to zero (RESET)
- b) At the end of the passage of interest store the current tape position in the internal memory (MEM STORE)
- c) To play over this section of tape, select CYCLE. The recorder will immediately execute a search and play operation. When the tape has played up to the stored tape position a further search - play command will be executed. This sequence will continue until "Stop" is pressed.
- d) The MEM STORE LED indicates that the tape is at the position stored in the internal memory
- e) The RESET LED indicates that the tape is at counter zero.

N.B. The counter resolution is 1/60th. of a second.

17.4 Record Selection (See also section 4.6)

The important difference between the SCM 760 and other machines in the range is that under no circumstances can any channel be entered into "record" by the record/ready select buttons.

The procedure is as follows:

- a) Individual or groups of tracks can be selected to "safe" or "ready" by record/ready select buttons.
- b) Record is selected by simultaneous depression of the record and play illuminated switches. The record switch must be released before the play switch. The reliable way to enter record is to "hold" the play and "dab" record. Note that the channels do not enter record until the pinch wheel has engaged. The illuminated record switch flashes until this has been achieved.
- c) Individual or groups of tracks can be punched out of record by pressing the record/ready select buttons. When this is done the track reverts to "ready". If the select button is pressed again, the track goes to "safe" mode.
- d) When the machine is in "record", further tracks can be selected to "ready". These extra tracks can be punched into record by a further depressing of play and record illuminated switches.

e) All tracks currently in "record" mode can be punched out together by pressing the illuminated record button by itself.

f) To achieve a fast punch in/punch out sequence (e.g. to re-record a single note) select the track of interest to "ready" by the select buttons. Select play mode and as the "punch in" point approaches.

Hold down the "record" switch.

To punch in: press the play switch

To punch out: release the play switch.

17.5. Autolocator

The autolocator has been specially designed for Soundcraft by Audio Kinetics (UK) Ltd., and provides many facilities to greatly improve the flexibility of the SCM 760 Series.

The best way to become familiar with the locator is by using it. The following descriptions are arranged as a self demonstration of all the main functions. Follow the instructions as written.

17.5.1 Data Entry



Numbers can be entered left shift (calculator style) into the locator display by pressing the 0-9 keys.

Pressing "clear" sets the locator display to 0.

17.5.2. Master Zero

The tape position indicator should be set up such that zero count is at the beginning of the reel. Although accidental excursions below master zero are permitted and do not confuse the computer, the locator will not operate properly in this area.

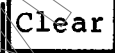
One way of setting this up is to wind the tape to the beginning of the reel and

Key:  

This clears the locator display to 0 and transfers that zero into the tape position display. Internally the computer refers all subsequent operations to this master zero.

17.5.3. Data Storage

Any number (except tape speed - see below) in the locator display can be stored in one of nine memory locations, by the use of the "store" key.

e.g. to store 10 mins 34 secs in memory 6, and 11 mins in memory 7

Key:

17.5.4. Locate function

The machine will search to any number (except tape speed) shown in the locator display. This can be done by manual entry e.g.

Key:

will cause the machine to fast wind to 30 seconds and stop. Alternatively, to a stored location which can be brought out of memory using the recall key e.g.

Key:

will cause the machine to fast wind to 10 mins 34 secs and stop.

17.5.5. Capturing tape positions

If, while the tape is in motion, a point of interest is noted, it's position on the tape can be simply stored using the position to keyboard key. This can be demonstrated by setting the machine into play mode. At some arbitrary time (say 11 mins 05 seconds).

Key:

The locator display will now hold 11 mins 05 seconds while the tape continues to play on. This can be stored for subsequent finding by:

Key:

17.5.6. Local Zero

Having finished one recording a second may be started at (for example) 15 mins. Tape positions can be displayed with respect to the start of the new recording by selecting local zero mode. Wind the tape manually to 15 minutes.

Key:

This causes the local zero LED to illuminate and the locator display to automatically clear. The transfer key sets this new zero into the tape position display. While in local zero mode all displays are referred to this new zero point.

When returning to master zero mode, the position display automatically converts the current tape position to read with respect to master zero and the locator display shows the position of the local zero with respect to the master zero. This enables the user to store the present local zero in a memory to come back to at a later time. The way this works can be demonstrated as follows:

Play up to (say) 1 minute (local) and stop.

Key:

this converts back to master zero mode. Tape position will now show 16 minutes (current position) and the locator display 15 minutes (local zero position).

Key:

Note: It is illegal to set local zero below the master zero. This would happen if a number larger than the master count was entered into tape position while in local mode.

Key: to go back to local zero mode.

Key: to try to enter 20 minutes as the local tape position.

Key: to return to master zero.

17.5.7. Cycle Function

It is often useful to go repeatedly over the same section of tape. This facility is provided by the cycle function. The cycle function always works between two stored memory locations. Assuming it is required to cycle between 11 minutes and 11 minutes 5 seconds (previously stored in memories 7 and 8 - see 17.5.3. and 17.5.5. above) the first action is to set up these positions as cycle limits.

Key:

Until these limits are changed, any pressing of the cycle key will cause the machine to search to the lower of the two tape positions and enter a play/wind/play sequence until some other command is received.

Key: to enter cycle mode.

Note that the cycle sequence always starts from the lower of the two stored tape positions keying 8 7 store cycle cycle has exactly the same effect.

17.5.8. Search to play

If it is required to do a search to a specific point and go into play without further action, a joint depression of the cycle and locate keys is required. If this position is not the lower cycle limit then locate must be selected first.

Key: to get 16 mins in display

Key: hold locate while dabbing cycle.

This causes the machine to search to 16 minutes and then play. To obtain a single pass over the section stored in the cycle limits it is not necessary to get the search point in display.

Key: hold cycle while dabbing locate.

This causes a search to 11 minutes and single play.

17.5.9. Recall key

This has a number of different functions.

a) To examine memory contents.

Key:

b) To examine the cycle limits currently set.

Key: to display cy 78 indicating that the cycle limits are memories 7 & 8.

Key: to examine what those limits are (11 minutes and 11 minutes 5 seconds)

c) To examine the last number in the locator display.

Key: brings back 11 minutes.

Key: brings back 11 minutes 5 seconds.

This function can be useful to catch two tape positions as described in 17.5.5. above.

To illustrate this function set the machine to play.

Key: to catch one tape position

Key: to catch another.

the second position could now be stored in a memory location as the tape continues on.

Key: to retrieve the first tape position which could now also be stored in another memory.

17.5.10. Speed Readout

The last function of the recall key is to display tape speed in inches per second.

Key: to achieve this.

Tape speed is displayed in all operating modes. Note that in wind modes the display is shifted two places to the right.

To remove tape speed from the display.

Key:

17.5.11. Further notes

a) Should the computer become confused or show signs of incorrect operation there is a reset button accessible by a matchstick or small screwdriver through the top (angled) panel of the remote unit. Actuating this switch causes:

All memory locations to clear to zero.

Learned deceleration patterns to be forgotten

Timed display of hurt feelings.

Complete restart of computer operation.

b) Some studios store multitrack tapes "tail out". The easy way of setting up for a new reel is to load the tape onto the machine and set current tape position for the length of tape.

Key: to set 30 minutes as current position.

Key: to find beginning of tape.

7.6 Speed Change

A speed change switch is provided on the lower rear panel of the machine. This has the effect of altering the speed of capstan rotation and the update rate of the tape position indicator. The audio channel is supplied (as standard) capable of being adjusted to either IEC standard (at 5 ips) or AES standard (at 30 ips). Other equalisations can be supplied on request. Note that L.F. eq. is not adjustable. No difficulty will be experienced in switching between 15 ips and NAB and 30 ips AES.

18. SCM760 SERIES ELECTRICAL SUBSYSTEMS

18.1 24 Track Remote Control - Wih Autolocator

Technical Description

18.1.1 General

The unit can be divided into three sections:

- a) Audio channel status control
- b) Transport control
- c) Computer

All three sections have access to the control surface (switch board) and so this shall not be treated as a separate item.

18.1.2 Audio channel control (See SM3222 and SM3221)

a) General

Audio control can be subdivided into two sections of interest:

- i) Monitor selection
- ii) Record/ready selection

Both sections rely on a 16 stage by 4 bit shift register as memory for the individual status of each channel (IC's 9&12, 40105). The output of each register is buffered by a 4 bit latch (IC's 2&5, 4042).

This provides 8, single bit, sixteen stage, shift register lines. These are allocated to cover sixteen channels of information each.

- | | | |
|--------|----------------|---------------------|
| (i) | Replay monitor | |
| (ii) | Line monitor | channels 1-8,17-24 |
| (iii) | Replay monitor | |
| (iv) | Line monitor | channels 9-16,25-32 |
| (v) | Safe/ready | channels 1-8,17-24 |
| (vi) | Safe/ready | channels 9-16,25-32 |
| (vii) | Record | channels 1-8,17-24 |
| (viii) | Record | channels 9-16,25-32 |

See monitor codes - section 8.3.4.

b) Shift register operation

The master clock is generated in IC29 and provides two signals to the shift registers, X and \bar{X} . \bar{X} is inverted and slightly delayed from X. X is used as the shift out command (SO) and \bar{X} provides a shift in command (SI). The time delay is provided since data input is inhibited when the shift register is full.

The X clock is also used to generate the channel select clock in IC30 and 31. The sequence of events is as follows:

- (i) latch output of 4042
- (ii) shift out next data block from register outputs
- (iii) shift in new data block into register inputs
- (iv) transfer next data block into 4042

The timing of these operations is shown below:

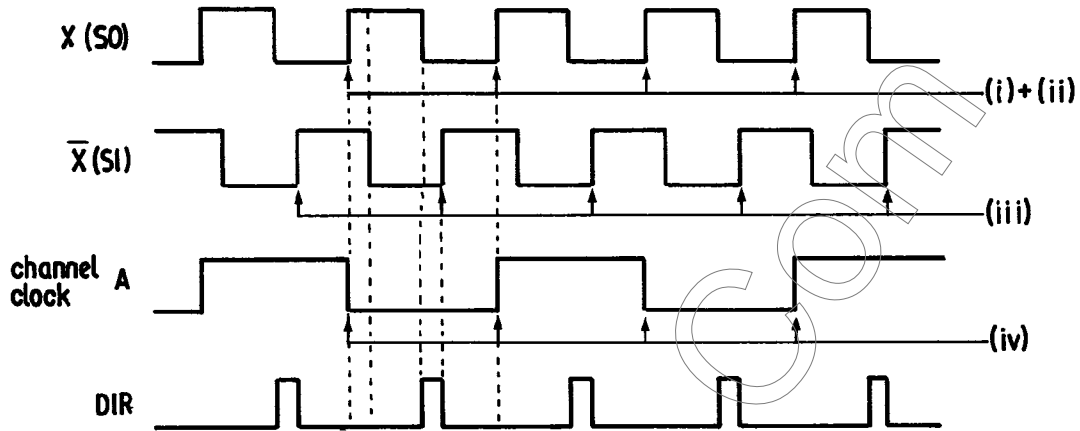

c) Channel allocation

While sixteen data words are contained in the recirculating shift register, only one of these is visible to the external circuitry at any one time and the channel number to which it relates is arbitrarily defined by the channel select clock code present at that time. This is achieved by only enabling the control switches in their appropriate time slot.

IC 28 and 32 perform this function as shown below:

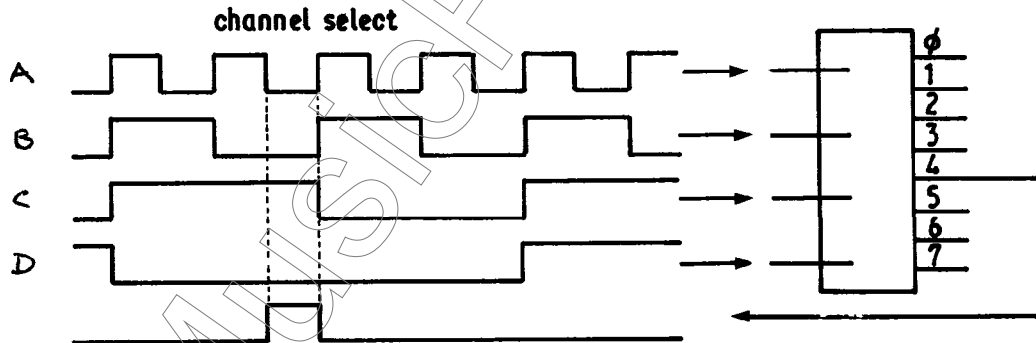

Thus only one of the sixteen update lines is active at any one time. Compatibility with 8 and 16 track machines is maintained by selecting channels 1-8 concurrently with channels 9-16 and using the D clock to select channels 17-24 (and for future use 25-32). Note that channels 17-24 arbitrarily share the 1-8 buses and 25-32 share the 9-16 buses.

d) Power up sequence

The shift registers will only operate correctly as described above if valid data is contained in all sixteen stages. To ensure that this condition is met, a power

on sequence first applies a master reset (MR) pulse from IC11 pin11. This clears all shift register stages during HT settling time. When this pulse is terminated, a monostable switches off the shift out (SO) clock thus enabling the register to fill up with valid data before the SO clock is re-enabled.

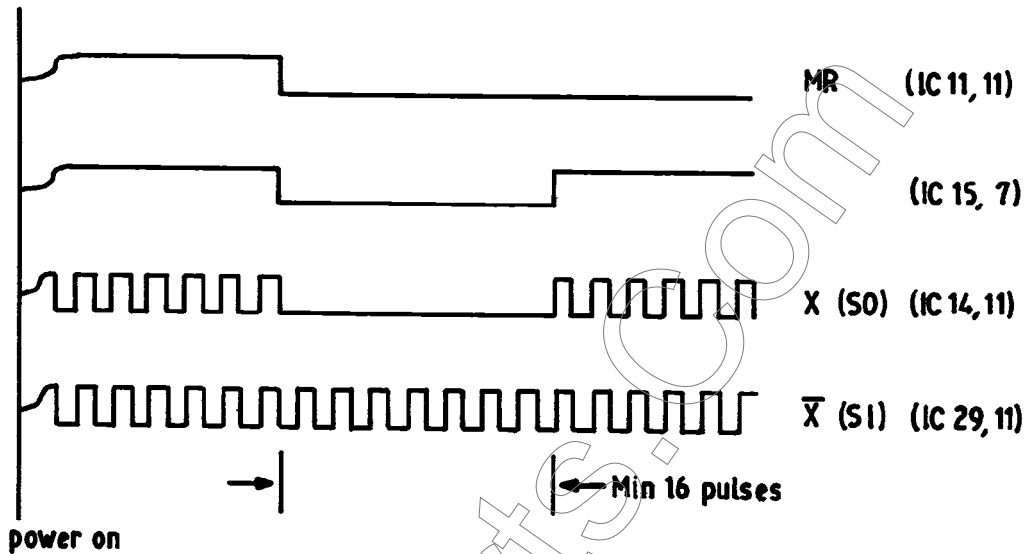

e) Monitor command latches

The system of generating the monitor command information is the same as described in section 8.3.4. The only difference is in the use of an analogue switch with positive feedback as the command latch, using two sections of IC25. (see below):

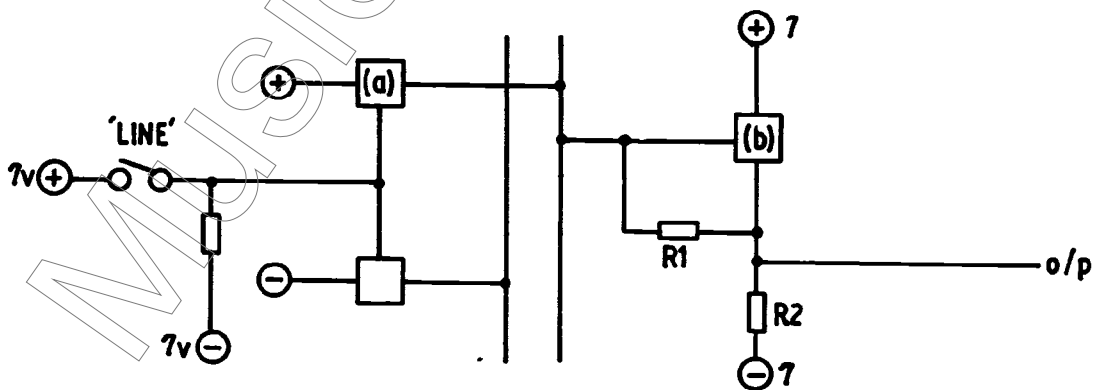

When 'line' is selected, switch (a) feeds logic 1 to switch (b), which is then closed and puts logic 1 to the o/p. R1 feeds back to the gate of switch (b) to maintain this level when 'line' switch is released.

f) Monitor Selection

One line of the monitor select register is shown below:

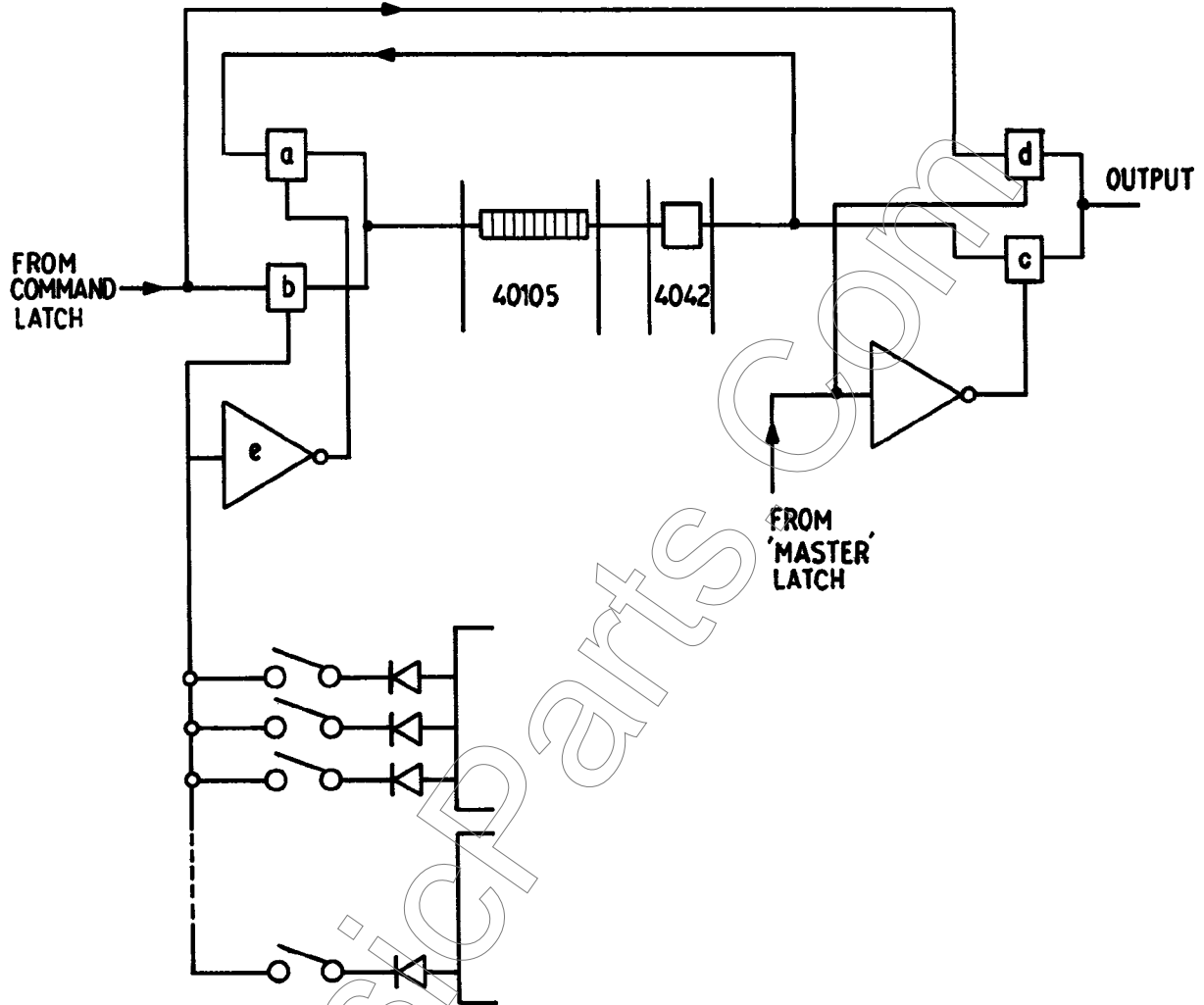

Under quiescent conditions the 16 bits of information recirculate via analogue switch (a). When any of the monitor update switches are closed a logic 1 pulse is applied to switch (b)'s control gate for the duration of the time slot allocated to the selected switch. At the same time the recirculating data is inhibited by inverter (e). New data is fed into the shift register by switch (b).

The output is normally connected via analogue switch (c) to the output of the shift register and thus contains multiplexed information for sixteen channels. When the master latch is set to logic 1, switch (c) is gated off and switch (d) routes the command latch status direct to all channels.

Decoding, muting and connection to the remote control bus is the same as in section 8.3.5

g) Safe/Ready Selection

One line of the safe/ready system is shown below:

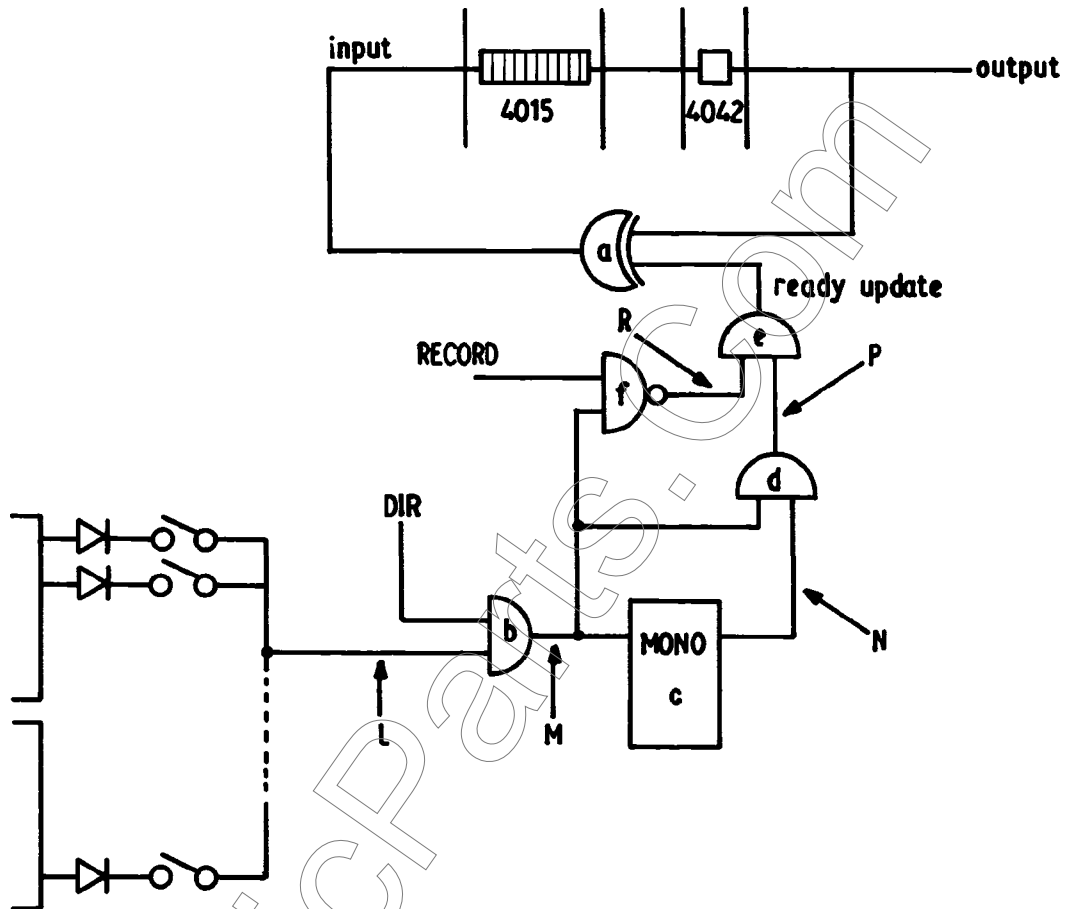

Under quiescent conditions, the 16 bits of information recirculate unmodified by the programmable inverter (a). A logic 1 on the 'ready update' line changes the state of one bit from 'safe' (logic 0) to 'ready' (logic 1) or vice versa.

When one of the ready switches is closed a logic 1 is supplied to gate (b) for the duration of the appropriate time slot. "Data In Ready" (DIR) from the shift register is used as a convenient strobe occurring in the middle of the time slot to trigger the re-triggerable monostable (c). The Q output is used, providing a logic 0 to gate (d) until the switch is released. Thus the output of gate (d) is a single pulse in the correct time window for the switch selected. Gate (e) inhibits this pulse if gate (f) detects that the track is currently in "record". Thus when a track is in "record" and the ready switch is selected the track remains in "ready".

The output of gate (e) is a "ready update" signal which inverts the recirculating shift register information. An example of timing relationships is shown below:

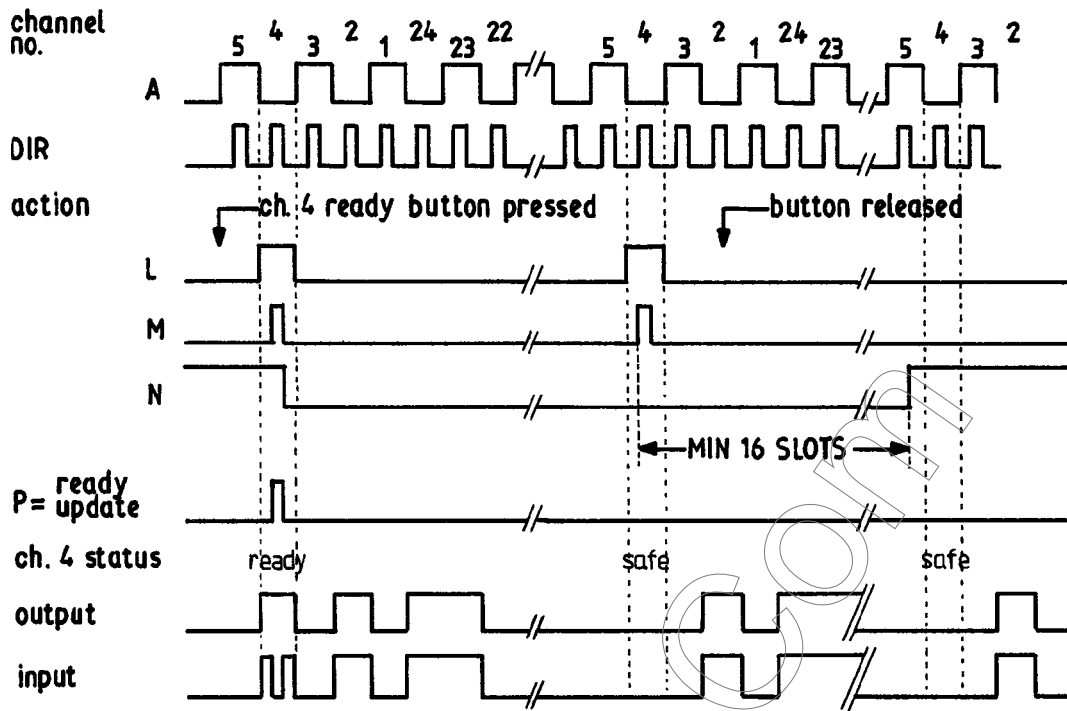

h) Record Selection

One line of the record register is shown below:

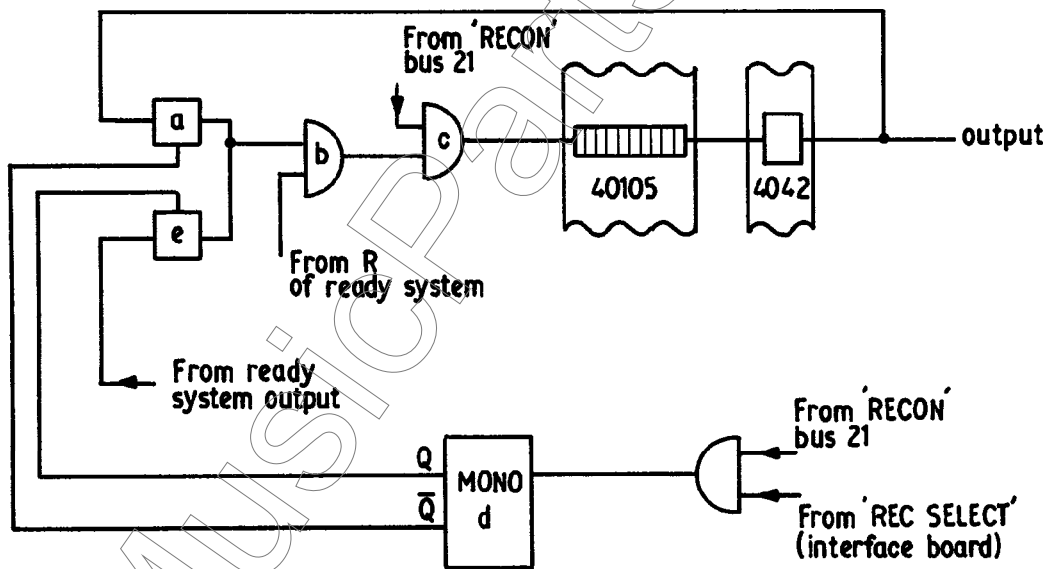

The 16 bit recirculating data is normally routed via analogue switch (a) and gates (b) and (c). Signal "R" from the safe/ready system is at logic 0 when a track is in "record" and that ready button is depressed. This sets the "record" data to logic 0 at the output of gate (b). Gate (c) acts as a master override and sets all channels to logic 0 when the "Record On" signal (remote control bus 21) is not present.

Whenever "Record On" goes from LO to HI or a "Record Select" pulse is received from the interface board (see below) monostable (d) is triggered for a period not less than 16 counts. This means that the contents of the ready register are copied into the record register, thus enabling "record" on those tracks already selected to ready.

18.1.3 Transport Control (see SM3223 and 3221)

a) General

The main function of the interface board SM3223 is to provide the necessary interfaces between the computer board and the machine.

Some additional functions are also provided:

b) Record Selection

The record selection system is the same as described in section 8.3.3. IC1,b forms the "record on" latch, and the reset signal is provided by IC2 pin10.

In addition to 'play' and 'record' buttons the record latch can be set by remote command from external equipment via TR3.

The monitor system (see above) requires a 'record select' signal in order to update the record register. This consists of a LO to HI transition on IC4,11 initiated whenever a new record command is received from TR3 or IC3,10 or when the "record on" (remote bus 21) goes HI. The last input is differentiated so that the first two still operate when the "Record On" bus is steady at logic '1'.

c) Transport commands and tallies

Commands received from the computer are in the form of active low (pull to ground) open collector drives. Pull up resistors are provided on the computer board.

Tallies provided to the computer are converted from +7v logic to 5v logic by IC's 5,6 and 7. IC's 6 and 7 are run from 5v H.T.

The play, fast forward, rewind and stop commands are differentiated in order that the computer (or external equipment) may examine the tally outputs for correct machine operation while command lines are being held low.

d) Varispeed

RL1 and RL2 provide means of transferring control of capstan speed between:

- (i) fixed speed presets located on the noise reduction interface in the machine
- (ii) the varispeed controls (physically mounted on the switch board SM3221) and
- (iii) an external source applied to the synchroniser interface connector

RL1 is operated by the varispeed switch and RL2 by an active low pull down from the external connector, via TR19.

Either command causes the varispeed switch to be illuminated via TR16 or TR17.

For further information see Synchroniser Interface (section 17.4).

e) Locator controls and display

The computer board provides a 4 bit output, designated A,B,C and D. These select between:

- (i) 1 of 8 display digits or
- (ii) 1 of 3 switch groups or
- (iii) the LED group

These are selected by IC8 and 9.

Note that IC9 is connected to +6v in order to provide LED current via TR14.

8 bits of information can be provided or requested by the computer for each of these outputs, which are designated by the digit segment they represent. Common connections are shown in the table below.

The segment lines have pull up resistors on the computer board. When a key group is selected the key group line is pulled to 0v by IC9. A closed switch in that group puts a logic '0' onto the segment line.

When the LED group is selected, a logic 0 on a segment line opens a current sink to ground through the high current buffer IC's.

When one of the eight display digits is selected, +24v is supplied to the digit anode by the driver IC on the display board. Any selected segments connect the PNP transistor bases to 0v through the current driver IC's. The transistors in turn apply +24v to the appropriate segment grids.

The flourescent displays have filaments driven from the +6v line.

The colon is treated as the eighth segment of the NMSD in each display.

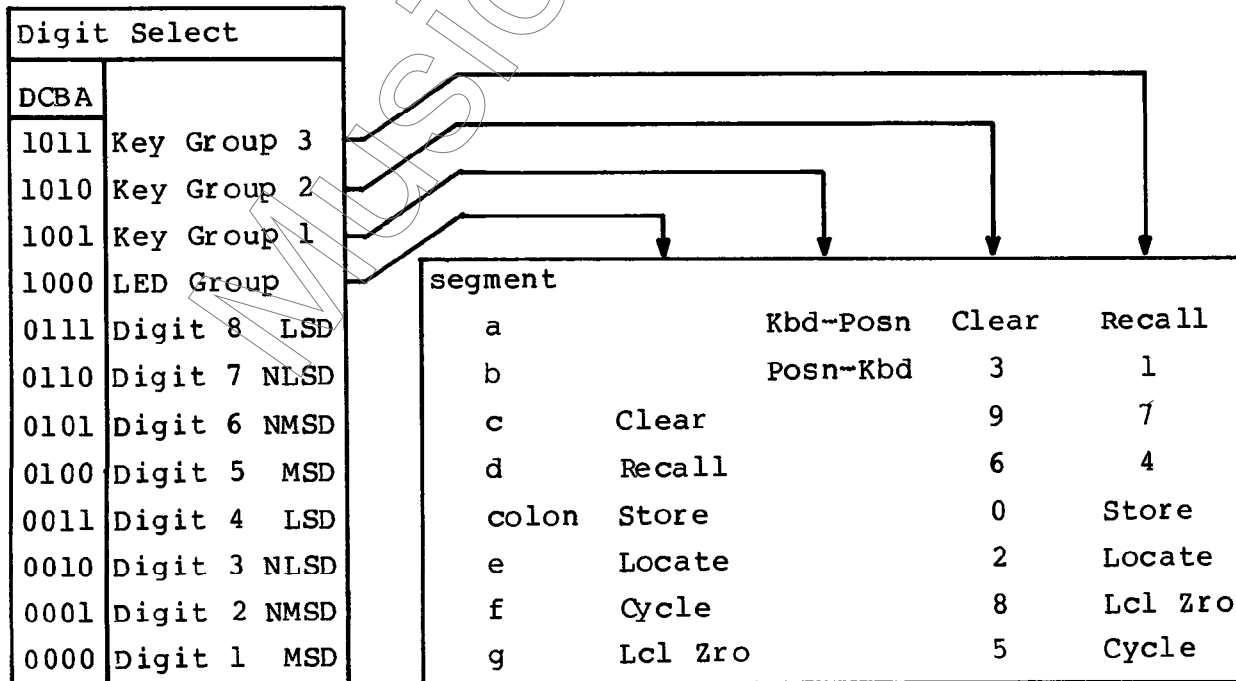

18.1.4 Computer Board

The computer board contains the microprocessor, PIA's, RAM, ROM and ancilliary components for the auto-locate system.

There is an on-board, 5v regulator, dedicated to the computer system. This is driven from the unregulated 9v line from the P.S.U.

Also included is a 6v regulator to drive the LED's and display filaments.

A reset switch is provided on the interface board. One side of this is grounded on the computer board. Actuating the reset button causes all RAM to clear and a complete restart of computer operation

The software is the property of Audio Kinetics Ltd, St.Albans, England.

MusicParts.com

18.2 16/24 Track Low Cost Remote Control

18.2.1 Audio Channel Control

a) Monitor command latches

These are formed round ICs 4 and 8. For a description of operation see section 18.1.2. (e).

b) Muting

The line monitor bus is fed directly to all channels, without muting, via IC2 and remote control bus 26 and 27. This ensures that:

- (i) Line monitoring mode is not muted.
- (ii) Sync monitoring mode mutes to line input.

The replay monitor bus is muted by a logic "0" on IC5 pin 10 indicating PINCH and MUTE DEFEAT. A logic "1" during a channel time slot can be provided by inserting a diode in the appropriate location on the outputs of IC6 or IC7 to override the muting of that particular channel.

c) Monitor status indication

Gating is provided from the Ready Indicator, line monitor bus and replay monitor bus such that the muting system causes the LEDs to flash the currently selected mode.

Note that in sync mode the muting switches the monitoring to input mode. This condition is indicated by a steady sync indicator and a flashing line indicator.

d) Safe/Ready/Record selection.

The operation of this system is identical to the remote control with autolocator.

See section 18.1.2

- a) General
- b) Shift register operation
- c) Channel allocation
- d) Power up sequence
- g) Safe/ready selection
- h) Record selection.

18.2.2 Transport Control

a) Counter and Display

See also section 8.3.1.

Count pulses from remote bus 2 are routed via a divide by two circuit in IC14. This is enabled by the speed change signal from remote bus 33, and provides correct minutes and seconds readout for 15 and 30 ips operation.

The seven segment outputs from the counter are fed to the fluorescent display via the display driver IC.

The digit outputs are fed to the display via transistor buffers, to raise the voltage drive. The "minus" sign is the asterisk symbol on the display unit, and is switched by the MINUS logic signal on IC6 pin 13 via a transistor switch in order to lower the source impedance to the display driver IC.

b) Cycle function

The counter IC (IC3) contains an internal register which can be loaded with the current counter information via IC15. The loading pulse is provided from IC8 pin 4, by depressing the "Store Mem" switch.

When the tape counter reads the same value as the stored register the "equal" output from IC3 pin 23 goes high to illuminate the "Store Mem" LED.

Operating the "cycle" switch initiates the following sequence:

- (i) Cycle latch set (IC8 pin 8)
- (ii) Cycle LED illuminated (IC8 pin 10)
- (iii) "Search" mode selected via IC7 pin 9 and D7 (see section 8.3.2)
- (iv) Play mode set via D11.
- (v) Search to play executed.
- (vi) When "equal" output detected, operations (iii)~(v) repeated via IC8 pin 13.

NB The resolution of the counter and the internal register is 1/60th second.

"Cycle" mode can only be cancelled by the "stop" button (via IC1, pin 11).

c) Search Function

Is as described in section 8.3.2.

e) Record Selection (see also section 8.3.3.)

The record latch (IC13 pin 3) is set via IC 19 pin 10 and reset via IC11 pin 4.

Note that the record select pulse (see 18.1.2 and 18.1.3 b) is generated either by selecting record and play switches or by a LO to HI transition on the remote control bus (21). The diode in series with IC 13 pin 10, allows an external device to select the system to "record".

f) Speed change

IC 14 contains a divide by two circuit which is enabled by the speed change (remote bus 33).

Thus the counter reads corrects minutes and seconds for both fixed speeds.

18.2.3 Disassembly

The entire assembly is removed through the front aperture of the casing, by undoing the six front panel retaining screws. The job is made easier by removing the upper (angled) panels of the casing in order to gain access to the back of the PCB assemblies.

If required the front panel can be simply lifted away from the top PCB after removing the push on varispeed knobs.

Illuminated transport control switches can be removed without disassembling the unit, by taking off the lens cap, removing the bulb and unscrewing the threaded sleeve inside the body of the switch.

When reassembling the unit ensure that the earthing strap is reconnected to the casing metalwork.

18.3 Interchangeable headblock

Recorders supplied with option I are fitted with a connector assembly immediately behind the headblock itself.

A full list of pin connections is shown on the drawing opposite

To change a headblock:

- a) Carefully separate each connector
- b) Undo the two bolts securing the headblock to the entry and exit guides.
- c) Install the new headblock and secure.

Providing the new headblock has been stored correctly there should be no need to alter any of the head adjustments.

MusicParts.com

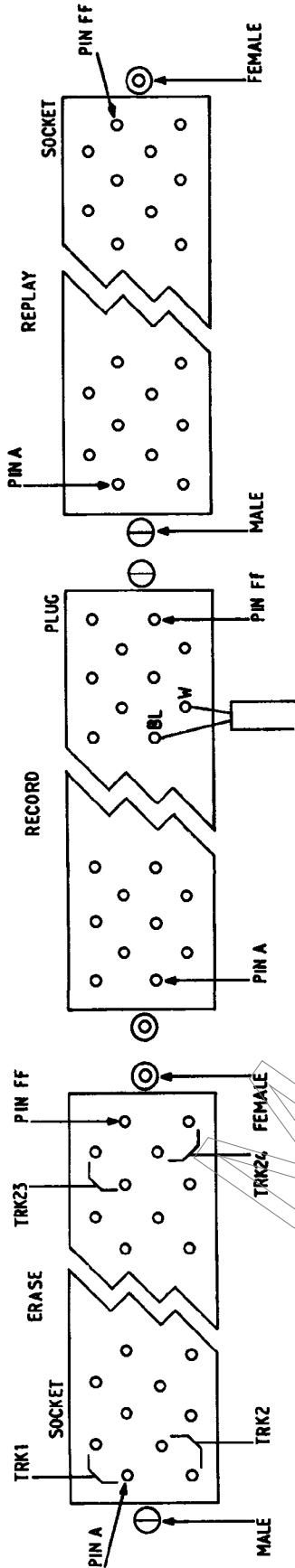

VIEW WIRING SIDE, DECK PLATE HALF

PIN TRACK	ERASE	RECORD	REPLAY	PIN TRACK	ERASE	RECORD	REPLAY
A	HOT	BL	RED	n	HOT	BL	R
B	SCREEN			p	COLD	W	W
C	1	W	WH	f	COLD	W	W
D	2	BL	RED	s	HOT	BL	R
E	3	BL	RED	t	HOT	BL	R
F	2	W	WH	u	COLD	W	W
H	3	W	WH	v	COLD	W	W
J	4	BL	RED	w	HOT	BL	R
K	5	BL	RED	x	HOT	BL	R
L	4	W	WH	y	COLD	W	W
M	5	W	WH	z	COLD	W	W
N	6	BL	RED	AA	HOT	BL	R
P	7	BL	RED	BB	HOT	BL	R
R	6	W	WH	CC	COLD	W	W
S	7	W	WH	DD	COLD	W	W
T	8	BL	RED	EE	HOT	BL	R
				FF	SCREEN		
				HH	24	COLD	W

18.4 External Control

There are two methods of connecting external equipment to control the operation of SCM 380 and SCM 760 series recorders.

NOTE ALL REFERENCE TO BUS NUMBERS IS TO WIRE NUMBERS IN THE FLAT CABLE USED TO IMPLEMENT THE SYSTEM

(see SM 76066 for conversion to standard D-type pin nos.)

18.4.1 Remote control bus

Full access to the control facilities of the recorder is available by fitting a Y cable adaptor to the remote control bus. See section 8.9 (Remote Control Bus - Summary) for a full list of the signals on the bus. A special cable assembly is available to convert an 8 track system to provide a 37 way connector.

a) Transport functions

Can be operated by a momentary connection of the appropriate bus to +7v.

Status tallies share the same bus as the command input. Examine the bus for +7v to indicate that a particular mode is in effect.

Note: The transport buses operate into high impedance latches and thus should not be loaded with TTL or discrete transistor devices. See sketch below for a typical command arrangement.

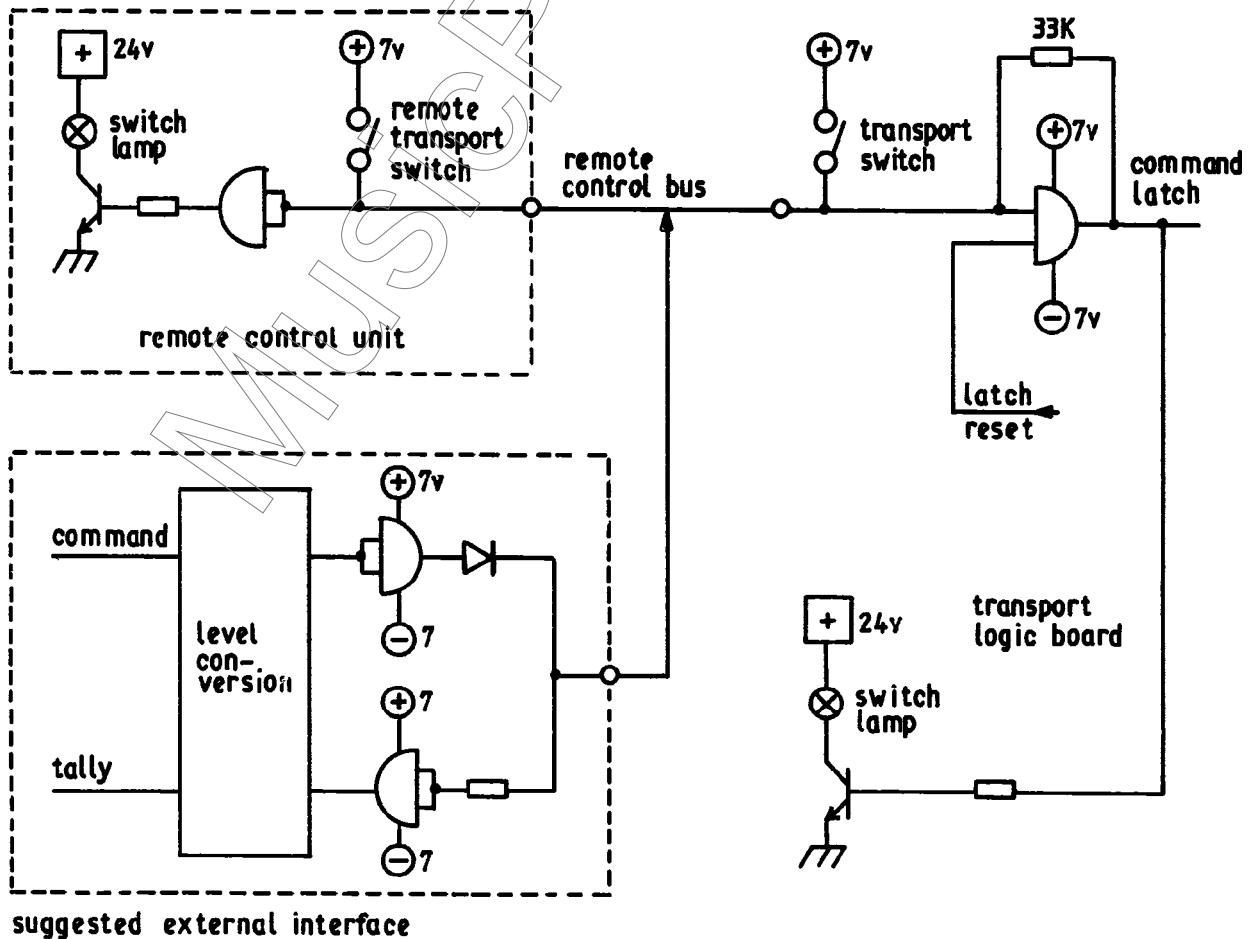

b) Search (bus 10)

The search command latch is located in 8 track and low cost remote control units. For system operation and circuit description - see the appropriate section.

The presence of this signal on the remote control bus can be used for external activation of a search to zero routine when either of these control units is in use. Momentary connection to +7v is required.

When used with the remote control with auto locator, which does not have a search latch, this bus can be used to enable the play command latch to be set without entering play mode. If the play command latch is set play mode will be entered as soon as the search bus is cleared to -7v. Steady connection to +7v is required.

c) Record On (bus 21)

See also audio channel section 8.1 and remote control section 8.3.3, 18.2.2 (e) or 18.1.3 (b)

Setting this bus high (+7v) enables the record system in the recorder. No audio channels will enter record until the "Pinch" signal (bus 4) is active. While waiting for this condition the record indicator flashes. Steady connection to +7v is required.

NB Later 8 track remotes have R1 on SM8038 replaced with a diode in order to avoid short circuiting the output of the record latch. If connecting external control equipment into an early machine check that this modification has been done.

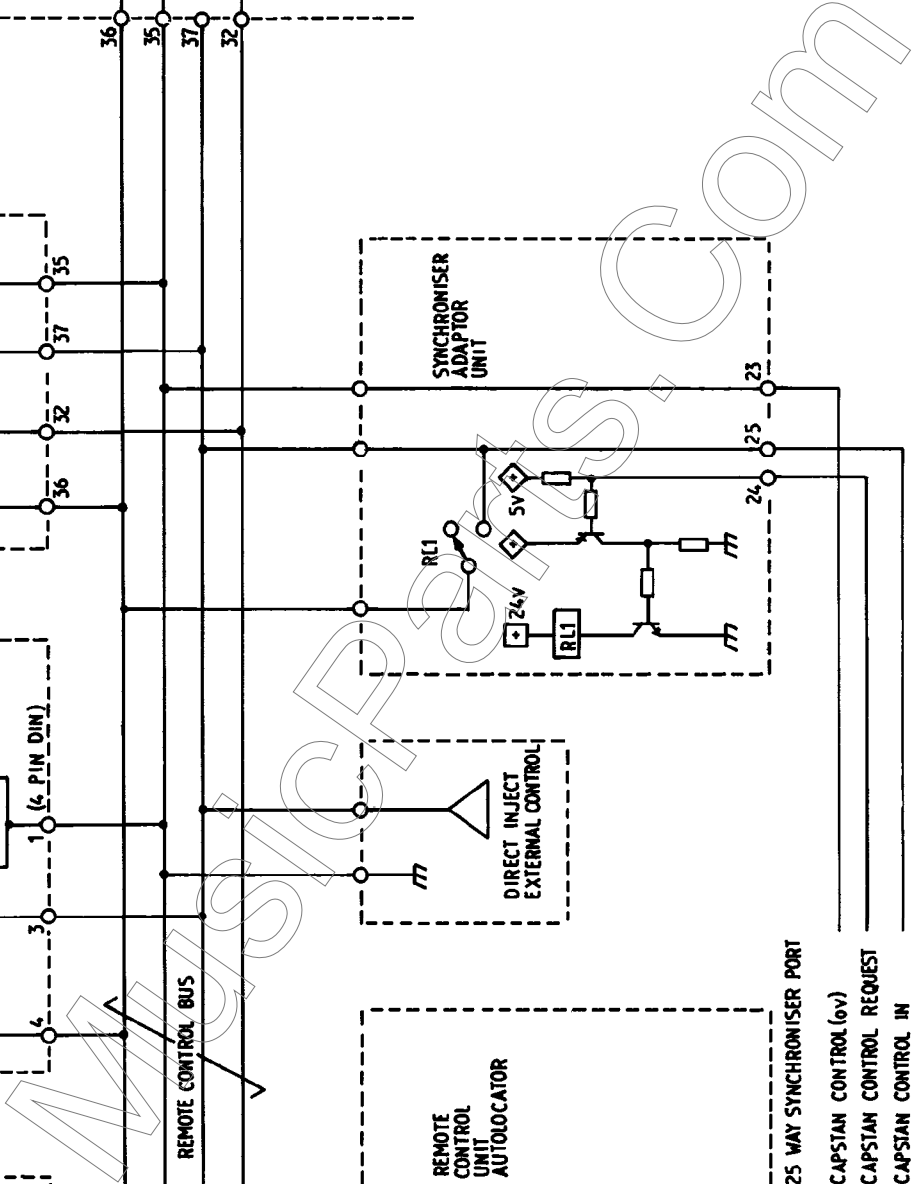
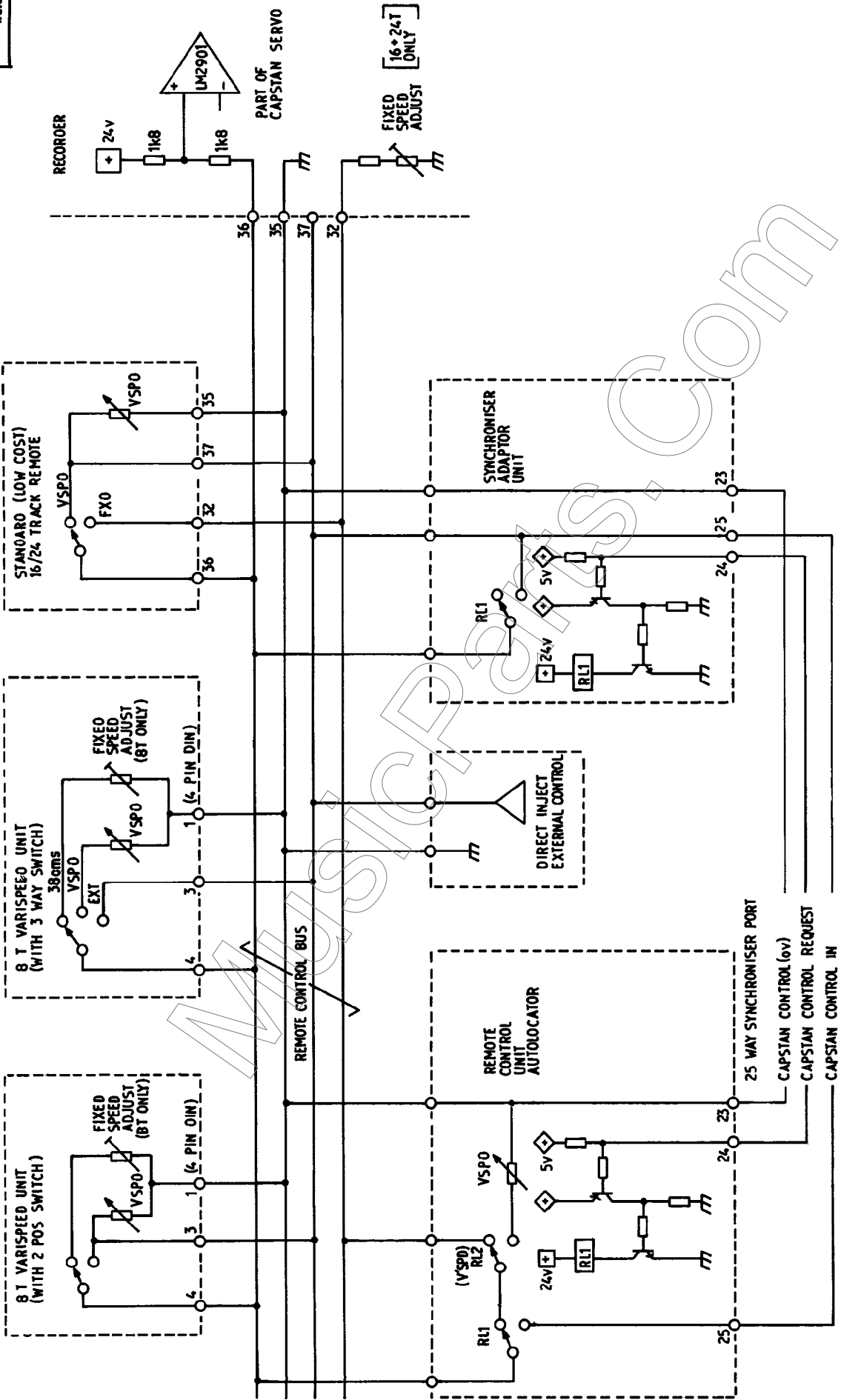

VOLTAGE CHARACTERISTIC OF CAPSTAN MOTOR - SCM 380 SERIES

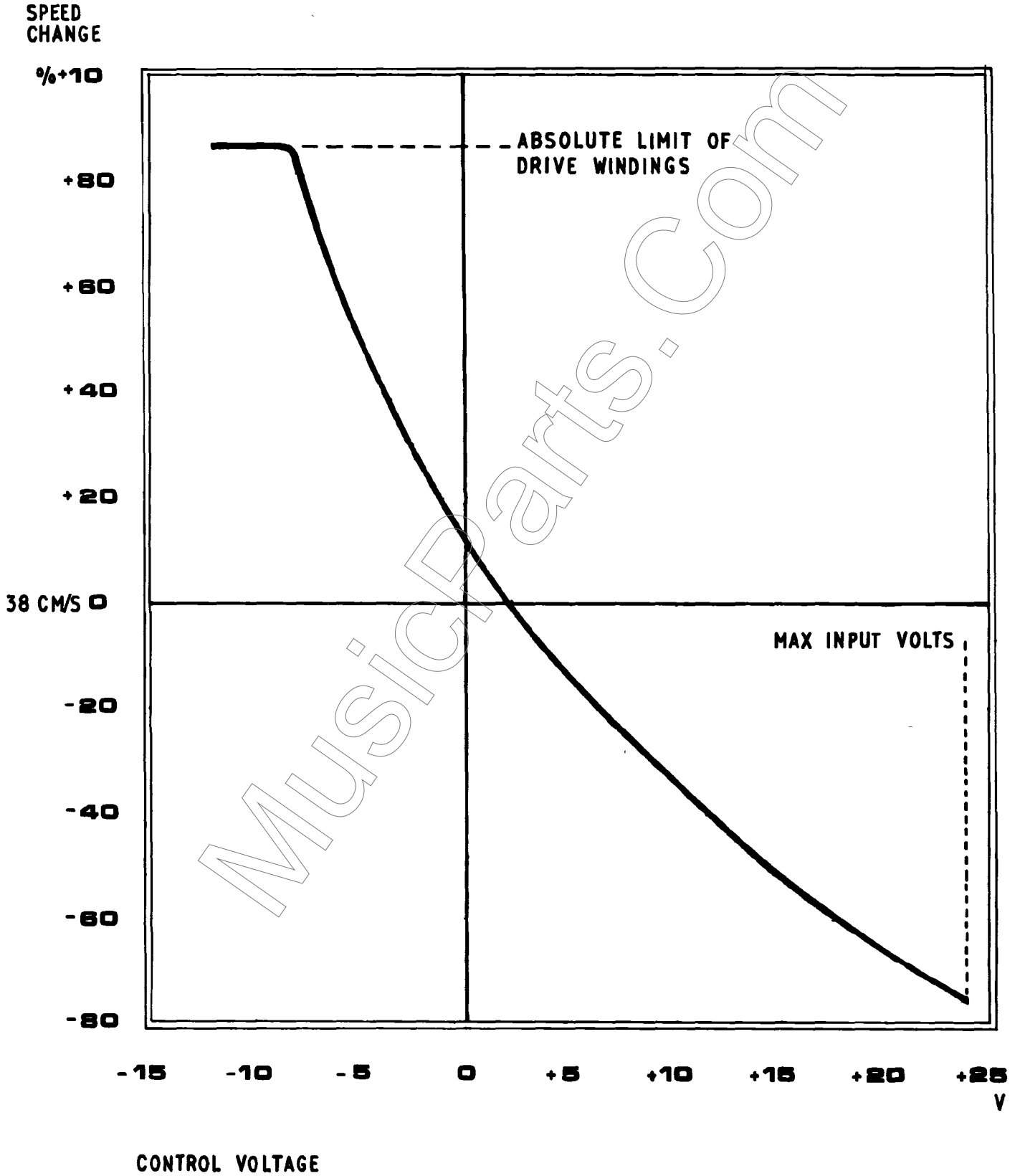

VOLTAGE CHARACTERISTICS OF CAPSTAN MOTOR SCM 760 SERIES - 30 ip.s VERSION

TAPE
SPEED
(i.p.s.)

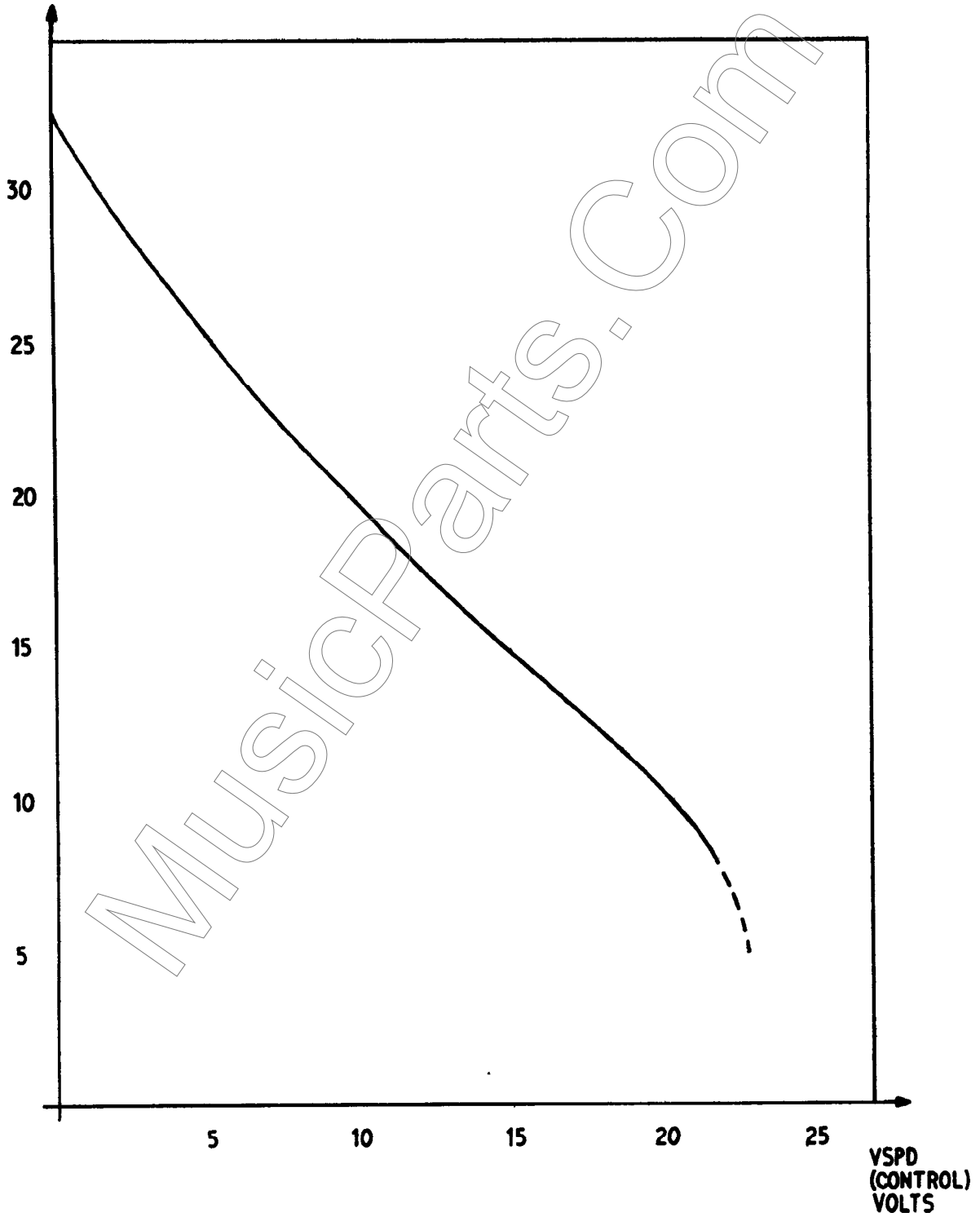

18.4.2 24 Track Remote Control - Synchroniser Interface

A 25 way D-type socket is provided on the rear of the remote control (with autolocator) providing all the necessary commands and status signals for an external synchroniser. The sketch below shows the orientation and pin designations as viewed towards the rear of the control unit.



1. General Notes

a) Audio Signals are not provided on this connector. Connections to the time code track must be made via the audio multicore.

b) When using a synchroniser it may be necessary to use the mute defeat facility to enable time code to be read in wind modes.

c) Command inputs and tally outputs are 5v logic, TTL and CMOS compatible. Inputs are active low (short to ground to actuate). Pull up resistors are provided internal to the remote control unit. Tally outputs are positive logic (+5v = logic 1 = condition present).

d) An adaptor unit can be constructed to plug into the 37 way remote control bus and which will provide a simulation of the 25 way socket. A suitable circuit diagram is shown below

2. Facilities

The following is a list of the wire numbers and the signals available. NOTE THESE ARE NOT STANDARD D-TYPE PIN NUMBERS.

1. Locate Command input: While held low enables the play command to be operated without being acted upon. Note: this command does not initiate a locate sequence.
2. SP.R. Command input : When pulled low initiates fast forward mode.

3. Play Command input : When pulled low puts machine into play mode (see LOCATE)
4. Stop Command input : When pulled low initiates stop sequence.
5. SP.L. Command Input : When pulled low initiates rewind mode.
6. Speed Logic Output : Square wave output, frequency proportional to speed of tape travel: 60Hz = 15 ips.
7. Pinch Logic Output : +5v indicates that pinch wheel has engaged with the capstan. Used to distinguish between a play command and play mode.
8. Speed change Logic Output : +5v indicates LO (lower of the two fixed tape speeds).
9. Direction Logic Output : +5v indicates forward tape motion.
10. SP.L. Logic Output : +5v indicates rewind command received.
11. SP.R. Logic Output : +5v indicates fast forward command received.
12. Play Logic Output : +5v indicates play command received.
13. Stop Logic Output : +5v indicates stop command received.
14. Not used
15. 0V Ground reference for machine
- 16.
17. +5v
18. +24v
19. Record Logic Output : +5v indicates record mode selected.
20. Record Command input : When pulled low activates record mode. Note: The machine will not enter record until the PINCH (see above) tally is present. Until this happens, the illuminated record switch on the remote control unit will flash.

21. Lift Defeat

Command Input : When pulled low will move tape into contact with the heads.
NOTE: this command does not operate on current machines, however, a reduced signal is available from the replay head without this facility.

22. Not used

23. VSPD (OV)

Separate ground reference for capstan control only.

24. Capstan control request

Command Input : When pulled low passes control of capstan speed to pin 25 (see below) and disconnects internal capstan control.

25. VSPD (Cntrl)

Control voltage input for capstan speed.

MusicParts.com

Motion Sense Assy: (8094)

Part No.	Description	Qty Per Assy
SM4001	'O' Ring	2
SM4005	Circlip	2
SM4014	Ballrace	2
SM3098	Tension Arm Post	1
SM3088	Disc - Co-Axial	1
SM4020	Thrust Washer	1
SM3077	Shaft - Motion Sense	1
SM3076	Housing - Bearing	1
SM4021	Pre-load Washer - Ballrace	1
SM3085	Disc - Motion Sense	1
SM4010	Spring - Disc Return	1

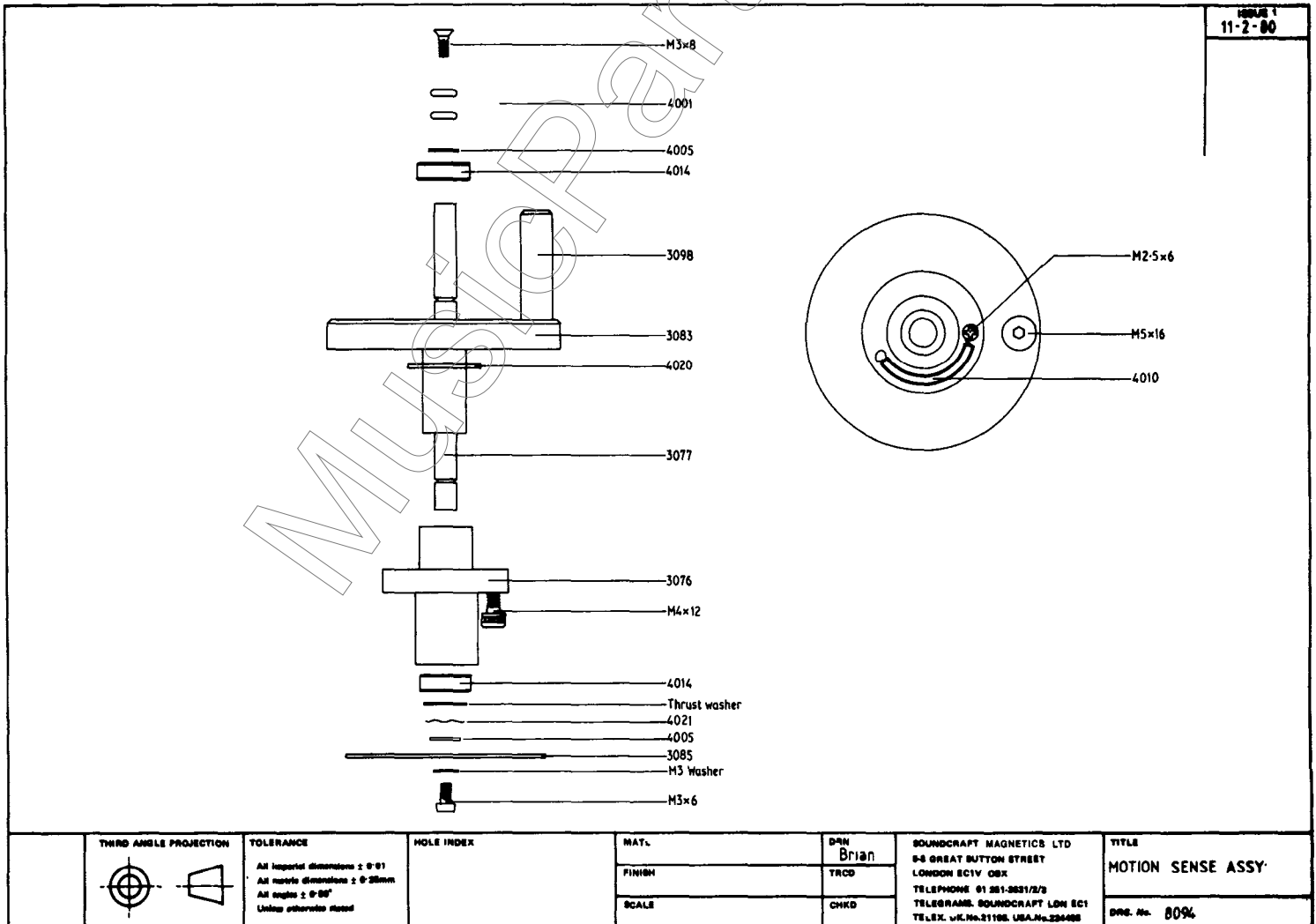

THIRD ANGLE PROJECTION

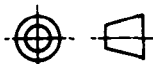

TOLERANCE

All important dimensions ± 0.01
 All metric dimensions $\pm 0.25mm$
 All angles $\pm 0.50^\circ$
 Unless otherwise stated

HOLE INDEX

MATL.

FINISH

SCALE

DRN

TRCD

CHKD

BOUNDCRAPT MAGNETICS LTD

8-8 GREAT BUTTON STREET
 LONDON EC1V 0BX
 TELEPHONE 01 261-2831/2/3
 TELEGRAMS BOUNDCRAPT LDN EC1
 TELEF. U.K. No. 21198. U.S.A. No. 226488

TITLE

MOTION SENSE ASSY

DRS. No. 8094

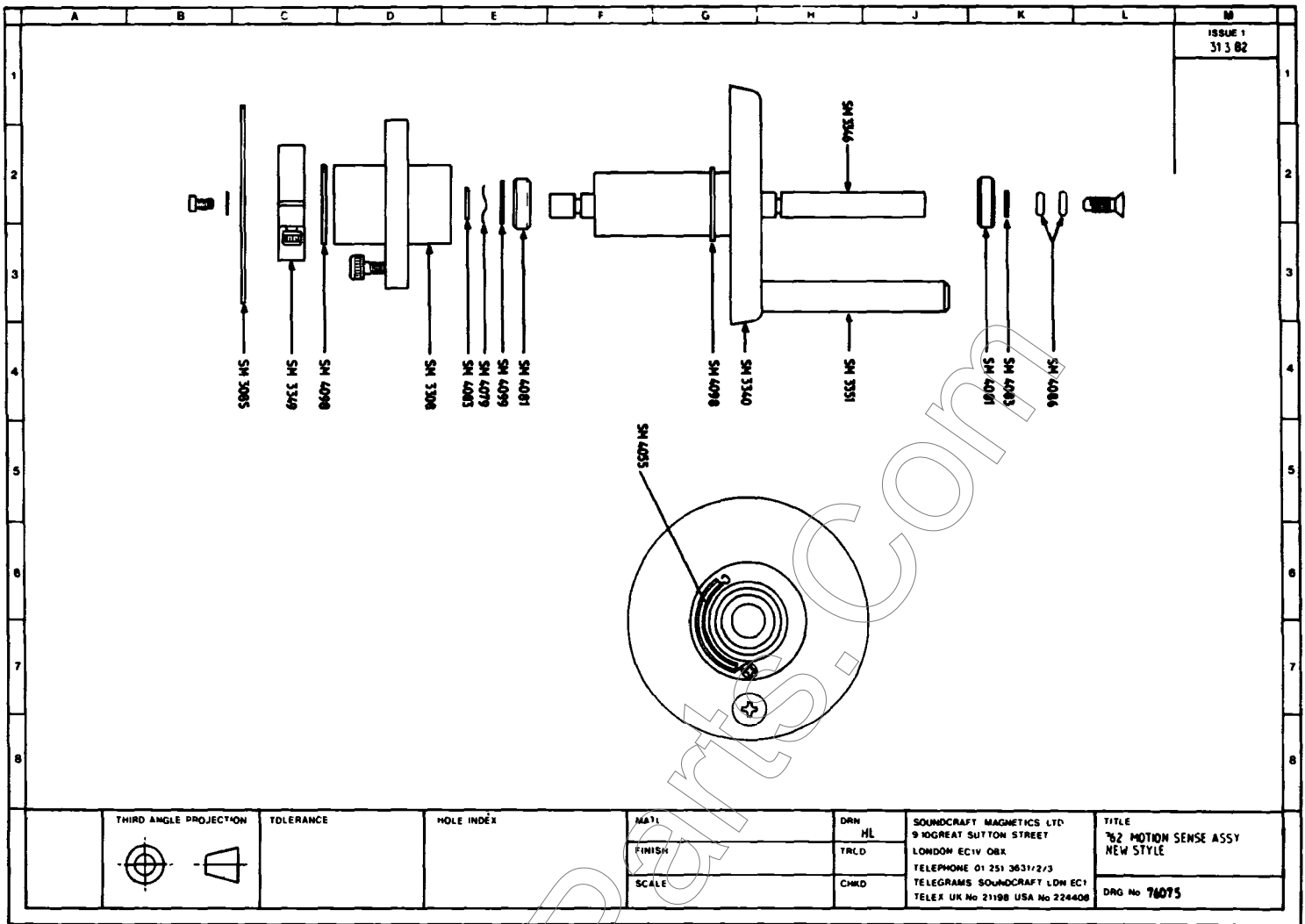

762 Motion Sense Assy: (76075) New Style

Ref. No.	Description	Qty. per Assy
SM 4086	'O' Ring	2
SM 4083	Circlip	2
SM 4081	Ballrace	2
SM 3346	Shaft - Motion Sense (8mm)	1
SM 3351	Post - Forward Tension	1
SM 3340	Disc - Co-Axial	1
SM 4098	Thrust Washer (Nylon)	2
SM 4055	Return Spring	1
SM 4099	Thrust Washer (Steel)	1
SM 4079	Washer - Bearing Pre-Load	1
SM 3308	Bearing Housing	1
SM 3349	Pinch Ring	1
SM 3085	Disc - Motion Sense	1

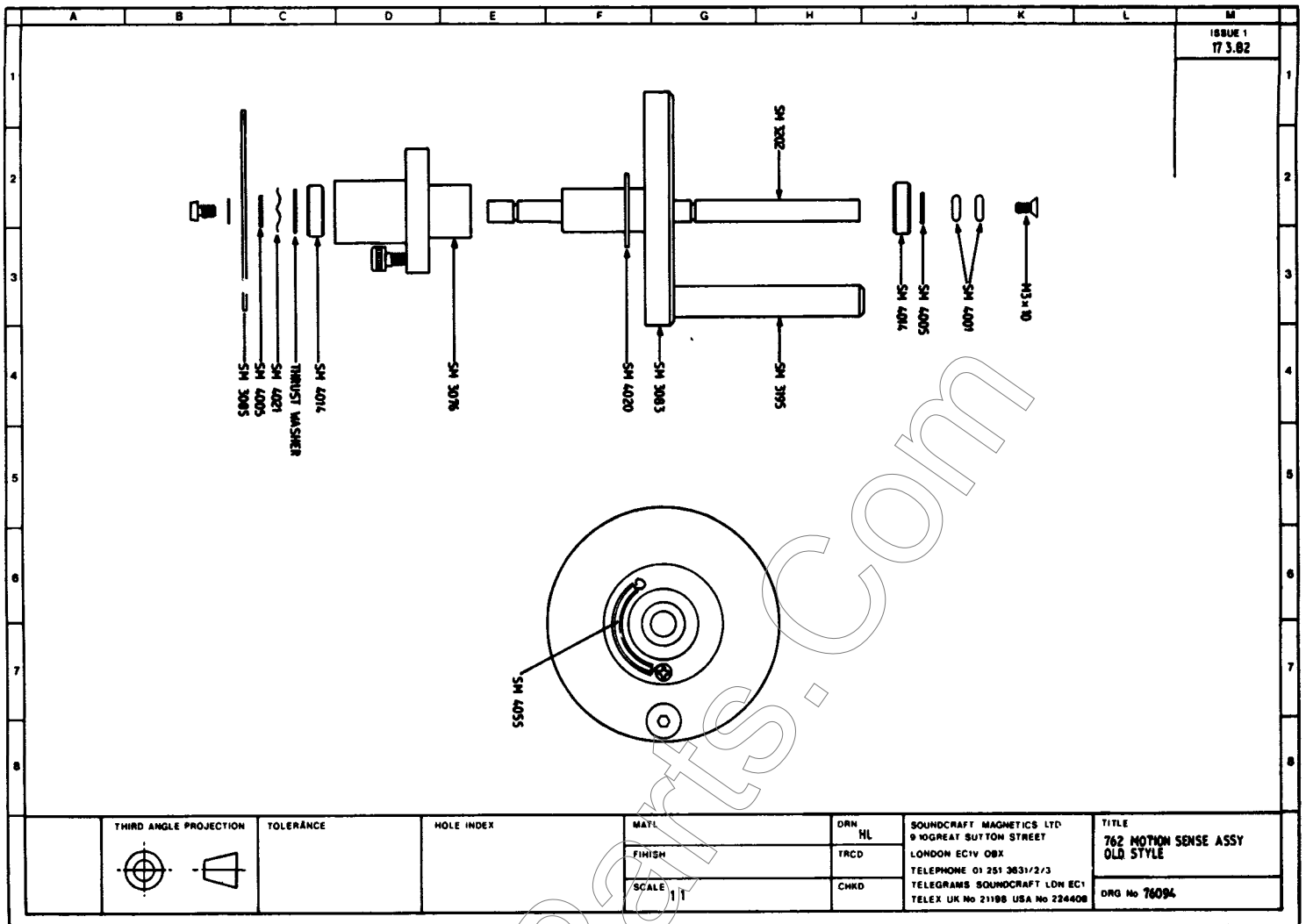

762 Motion Sense Assy: (76094) Old Style

Ref. No.	Description	Qty. Per Assy
SM 4001	'O' Ring	2
SM 4005	Circlip	2
SM 4014	Ballrace	2
SM 3202	Shaft-Motion Sense (1/4)	1
SM 3195	Post-Forward Tension	1
SM 3083	Disc-Co-Axial	1
SM 4020	Thrust Washer (Nylon)	1
SM 4055	Return Spring	1
SM 3076	Bearing Housing	1
SM 4021	Washer-Bearing Pre-Load	1
SM 3085	Disc-Motion Sense	1

Capstan Motor Assy: (8096)

Part No:	Description	Qty Per Assy
SM3103	Plate - Motor Mount	1
SM Type 1	Capstan Motor	1
SM3130	Bracket - Servo Mount	1
SM3118	Dress Cap - Capstan Motor	1

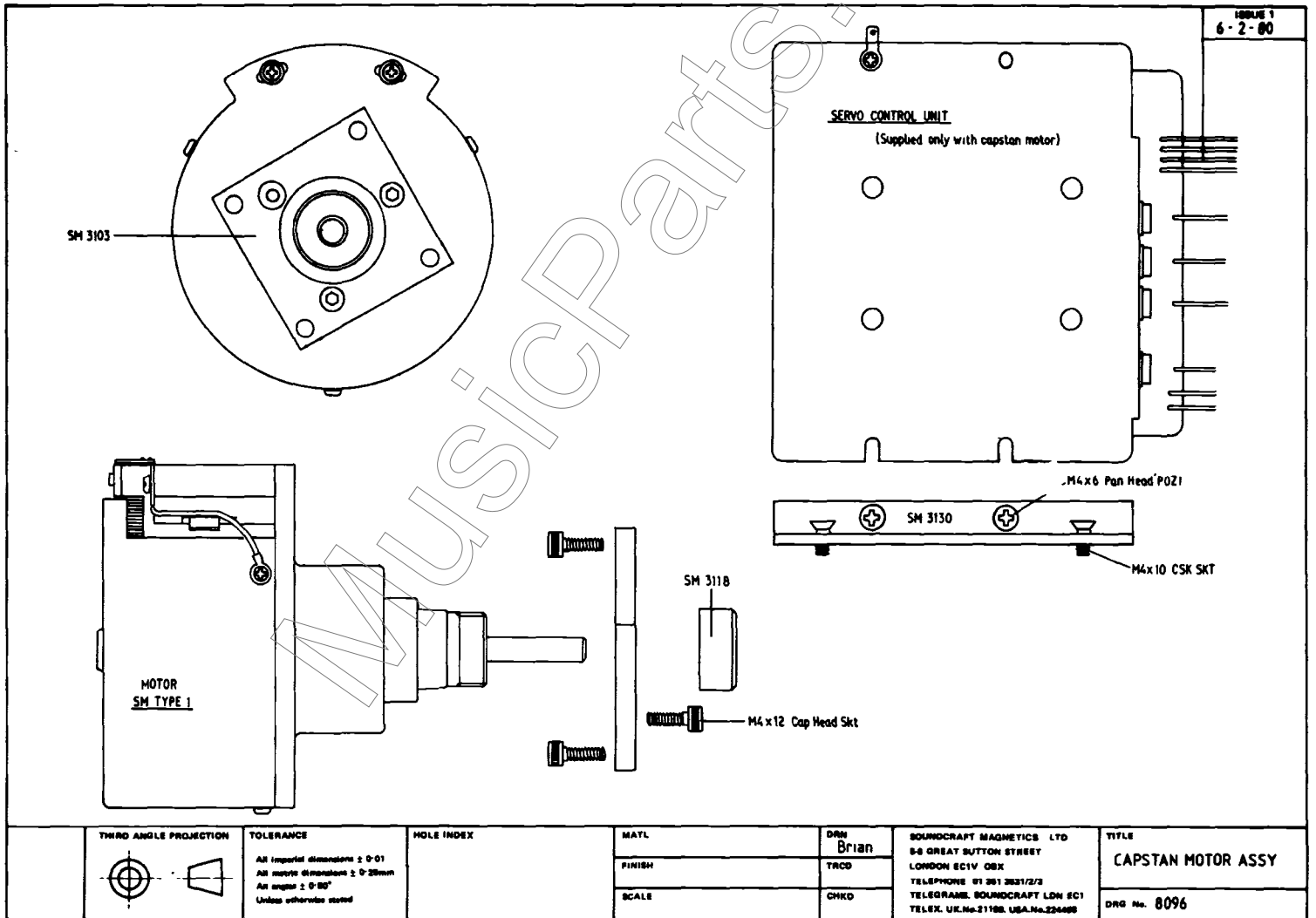

THIRD ANGLE PROJECTION 	TOLERANCE All imperial dimensions ± 0.01 All metric dimensions $\pm 0.25\text{mm}$ All angles $\pm 0.50^\circ$ Unless otherwise stated	HOLE INDEX	MATL	DRN Brian	BOUNDCRAFT MAGNETICS LTD 8-8 GREAT BUTTON STREET LONDON EC1V 0BX TELEPHONE 01 261 2631/2/3 TELEGRAMS: BOUNDCRAFT LDN EC1 TELEX: UK.No.21198, USA.No.224488	TITLE CAPSTAN MOTOR ASSY
			FINISH	TRCD		

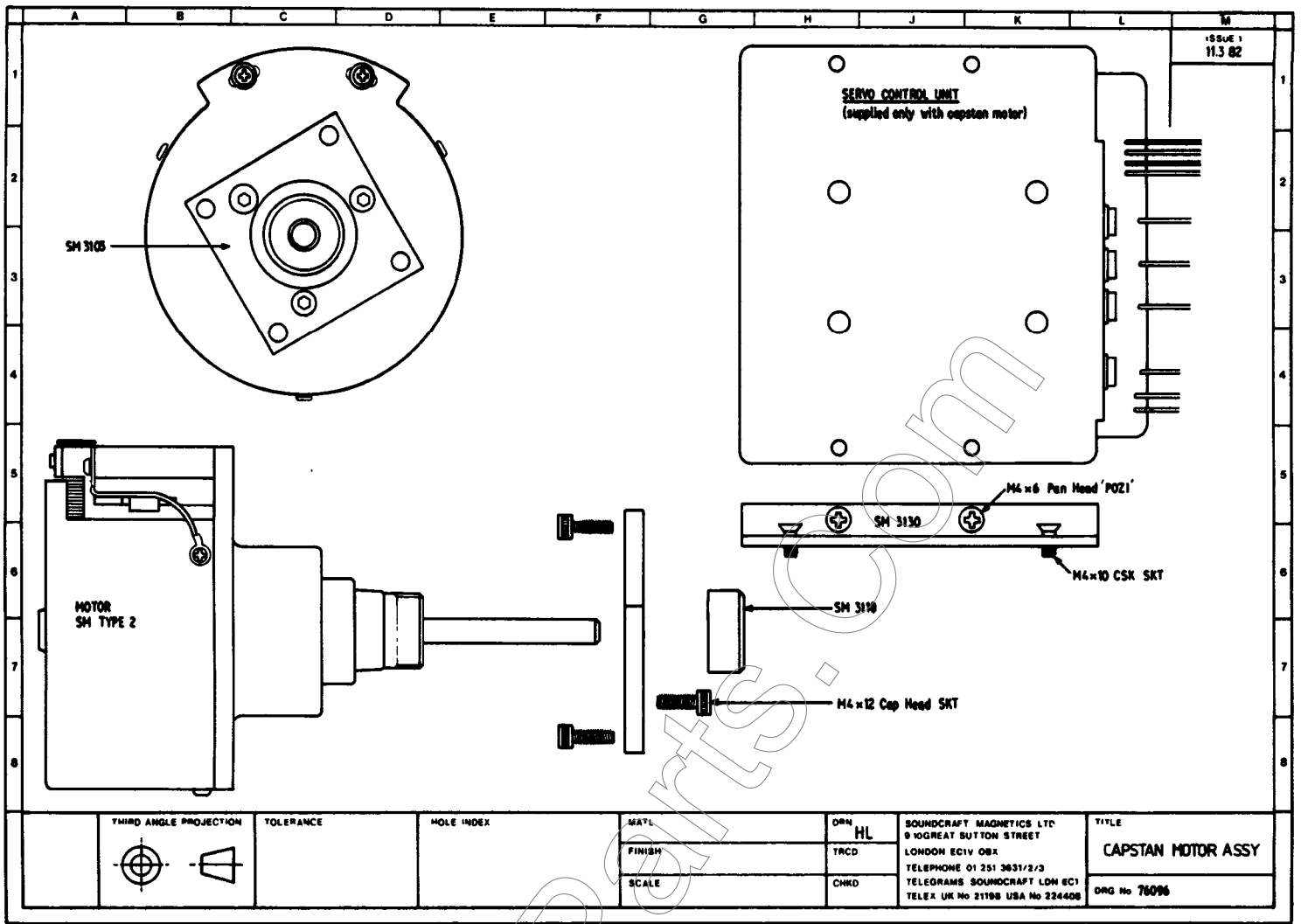

Capstan Motor Assy: (76096)

Ref. No.	Description	Qty. per Assy
SM 3103	Mount Plate	1
SM Type 2	Capstan Motor	1
SM 3130	Bracket - Capstan Servo	1
SM 3118	Dress Cap	1

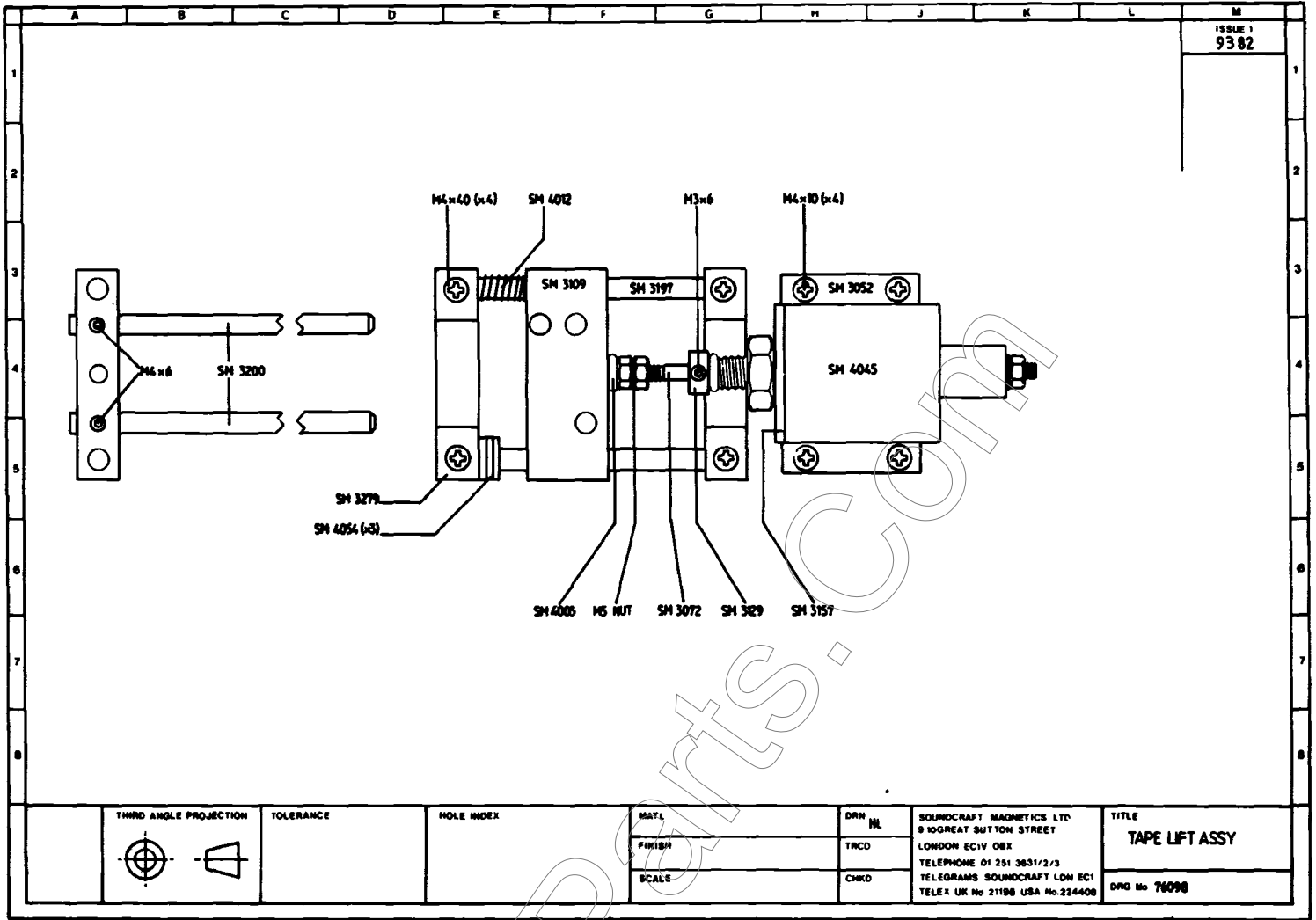

Tape Lift Assy: (76098)

Ref. No.	Description	Qty Per Assy:
SM 3200	Pin-Tape Lift (2")	2
SM 3075	Pin-Tape Lift (1") (Not Shown)	2
SM 3279	Rail Support Bracket	2
SM 4012	Spring-Slide Return	1
SM 4054	Felt Buffer	3
SM 3109	Slide-Tape Lift	1
SM 3197	Slide Rail	2
SM 4003	'O' Ring	2
SM 3072	Control Rod	1
SM 3129	Adjustment Collar	1
SM 3157	Head Wiring Bracket	1
SM 4045	Solenoid	1
SM 3052	Mount Plate	1

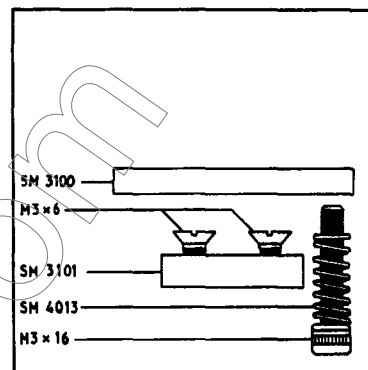
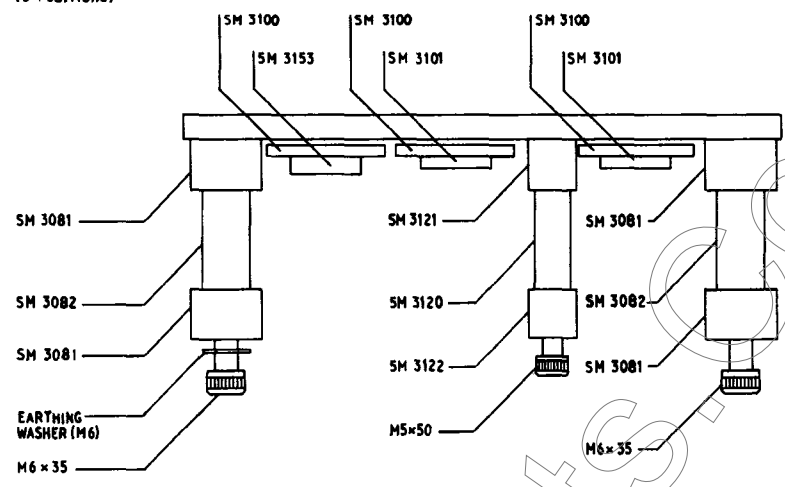
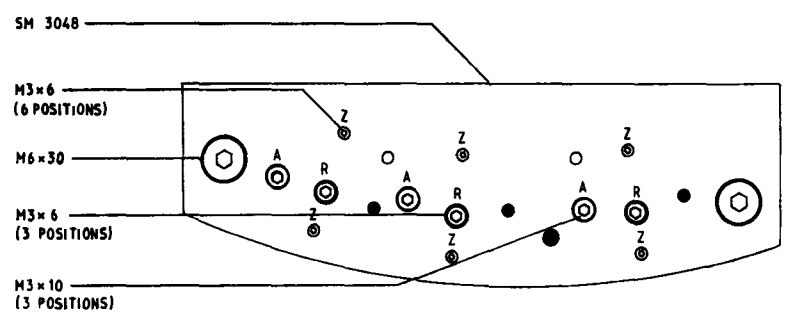

	TOLERANCE All imperial dimensions ± 0.01 All metric dimensions ± 0.25mm All angles ± 0.50° Unless otherwise stated	MOLE INDEX	MATL: Brian	DRN: Brian	SOUNDCRAFT MAGNETICS LTD 5 8 GREAT SUTTON STREET LONDON EC1V 0BK TELEPHONE 01 281 3831/2/3 TELEGRAMS: SOUNDCRAFT LON EC1 TELEX: UK No 21198, USA No. 224408	TITLE HEAD BLOCK ASSY:
			FINISH:	TRCD		DRG No 8100
			SCALE	CHKD		1179K

Head Block Assy: (8100)

Ref. No.	Description	Qty. per Assy
SM 3048	Headblock	1
SM 3081	Outer Tape Guide Upper/Lower	4
SM 3082	Outer Tape Guide Centre Section	2
SM 3121	Inter Head Guide Upper	1
SM 3120	Inter Head Guide Centre	1
SM 3122	Inter Head Guide Lower	1
SM 3100	Head Adjust Disc	3
SM 3153	Head Mount Disc	1
SM 3101	Head Mount Disc	2
SM 4013	Azimuth Pre-Load Spring	3

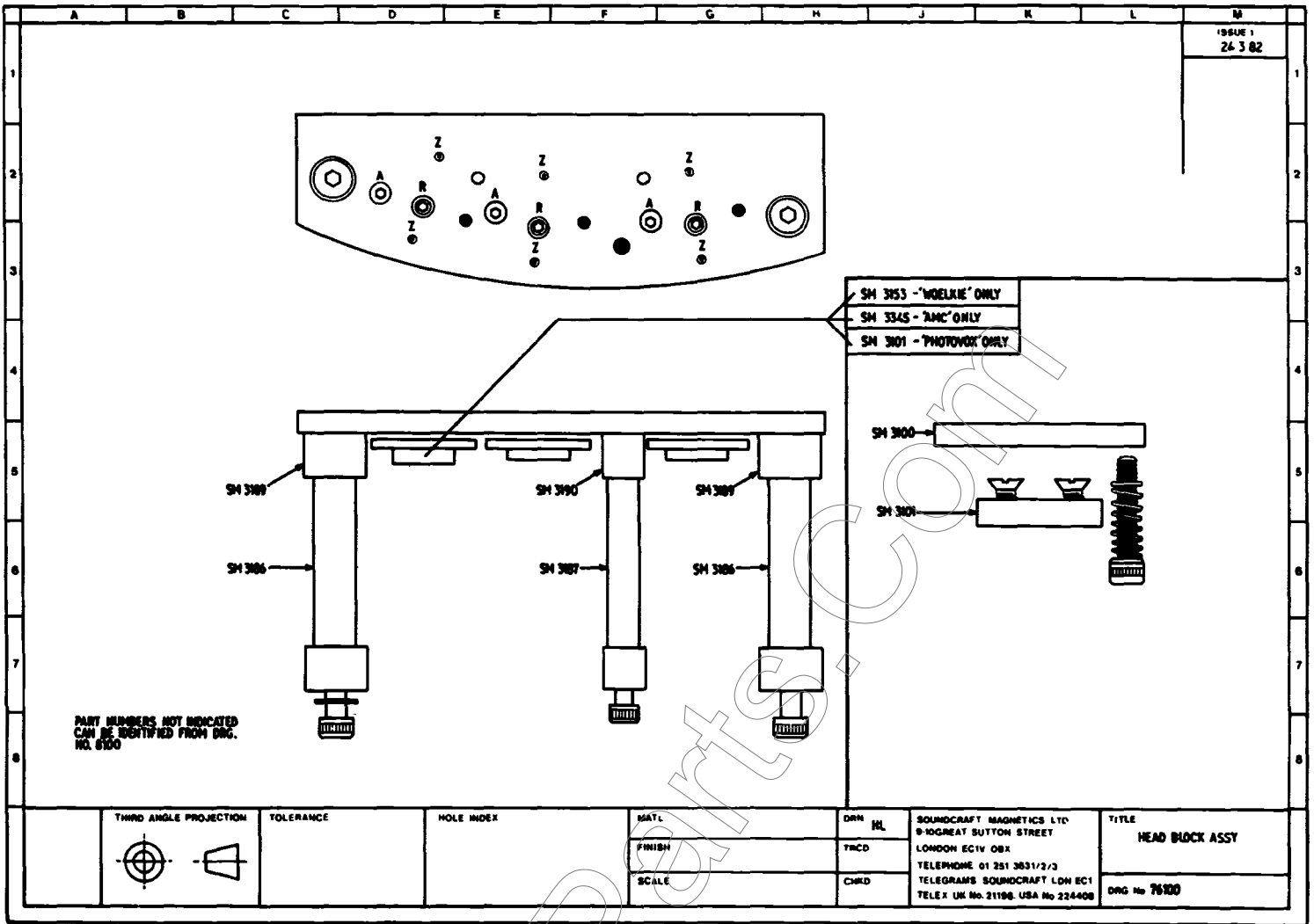

Head Block Assy: (76100)

Ref. No.	Description	Qty. per Assy
SM 3153	Head Mount Disc (See Diaq.)	1
SM 3345	Head Mount Disc (See Diaq.)	1
SM 3101	Head Mount Disc (See Diaq.)	1
SM 3100	Head Adj. Disc	3
SM 3189	Outer Guide Upper	2
SM 3186	Outer Guide Centre	2
SM 3190	Inter Head Guide Upper	1
SM 3187	Inter Head Guide Centre	1

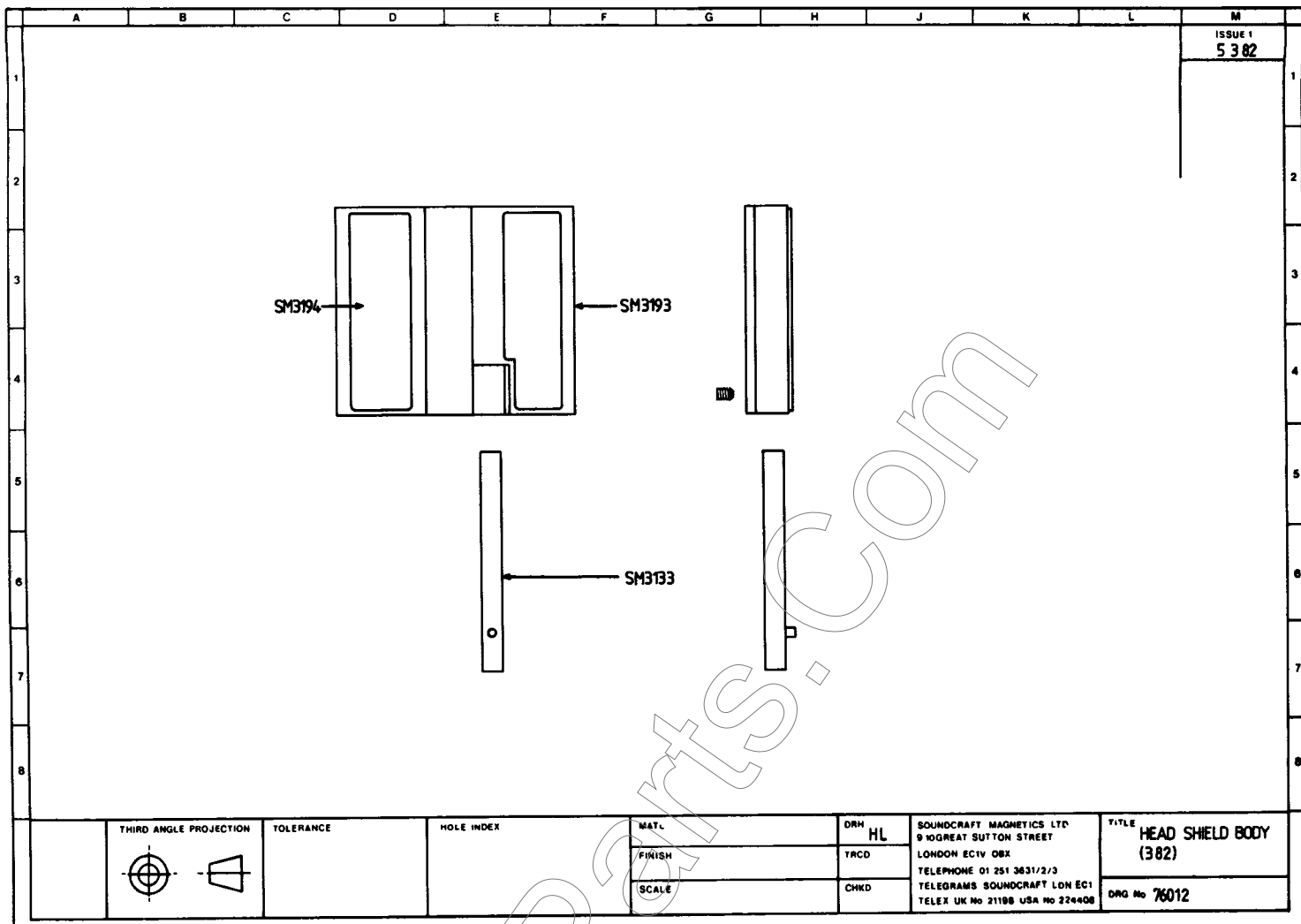

Head Shield Assy: (76012)

Ref. No.	Description	Qty per Assy
SM 3193	Head Shield Body	1
SM 3194	Head Shield Screen	2
SM 3133	Pin Assy:	1

Spool Motor & Spool Carrier Assy

8087

8043

Part No.	Description	Qty Per Assy
SM4024	Spool Motor	1
SM3111	Spool Retainer	1
SM4018	Washer - Split Thrust	1
SM4002	'O' Ring	1
SM3119	Drive Pin	1
SM3110	Spool Carrier	1

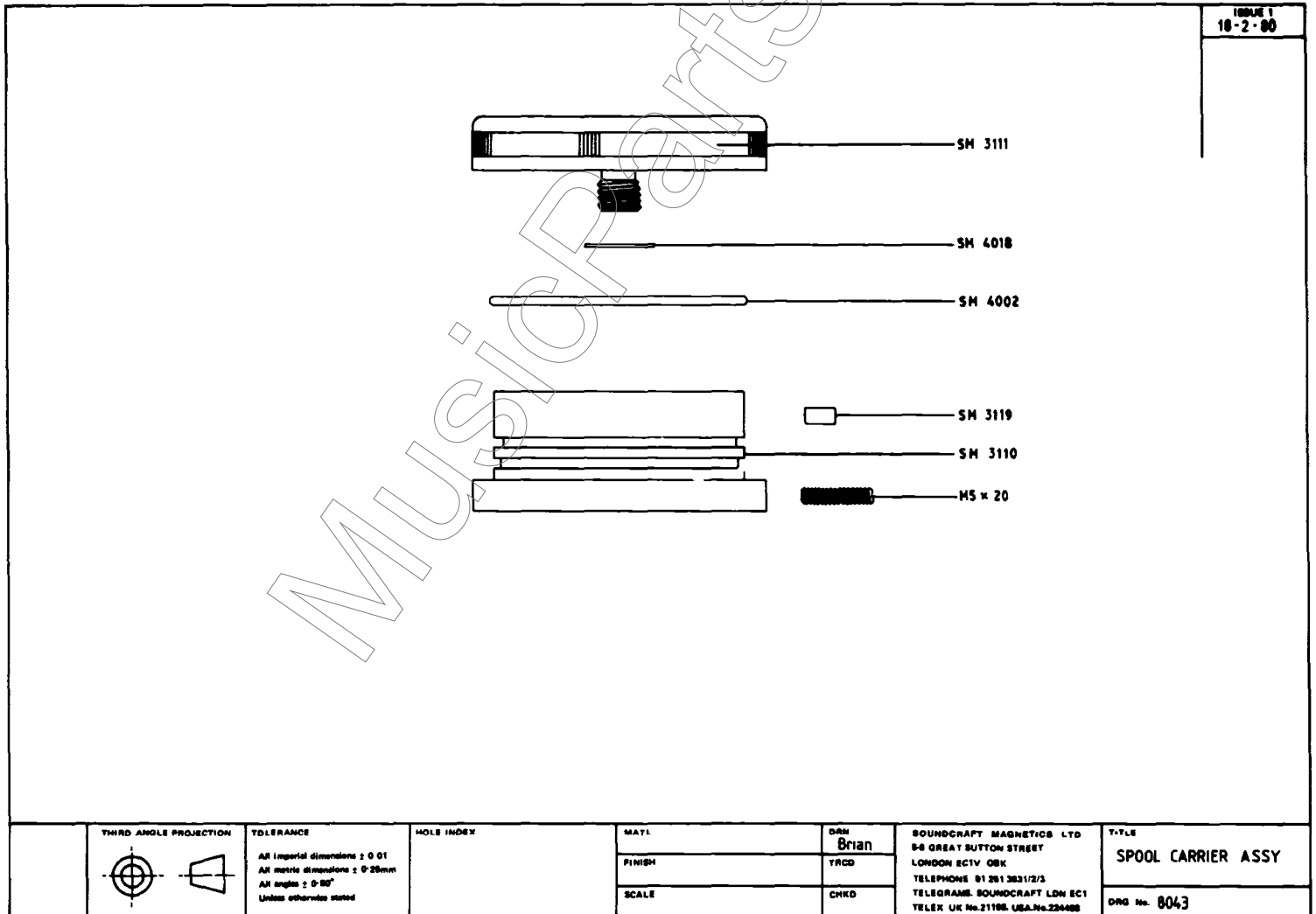

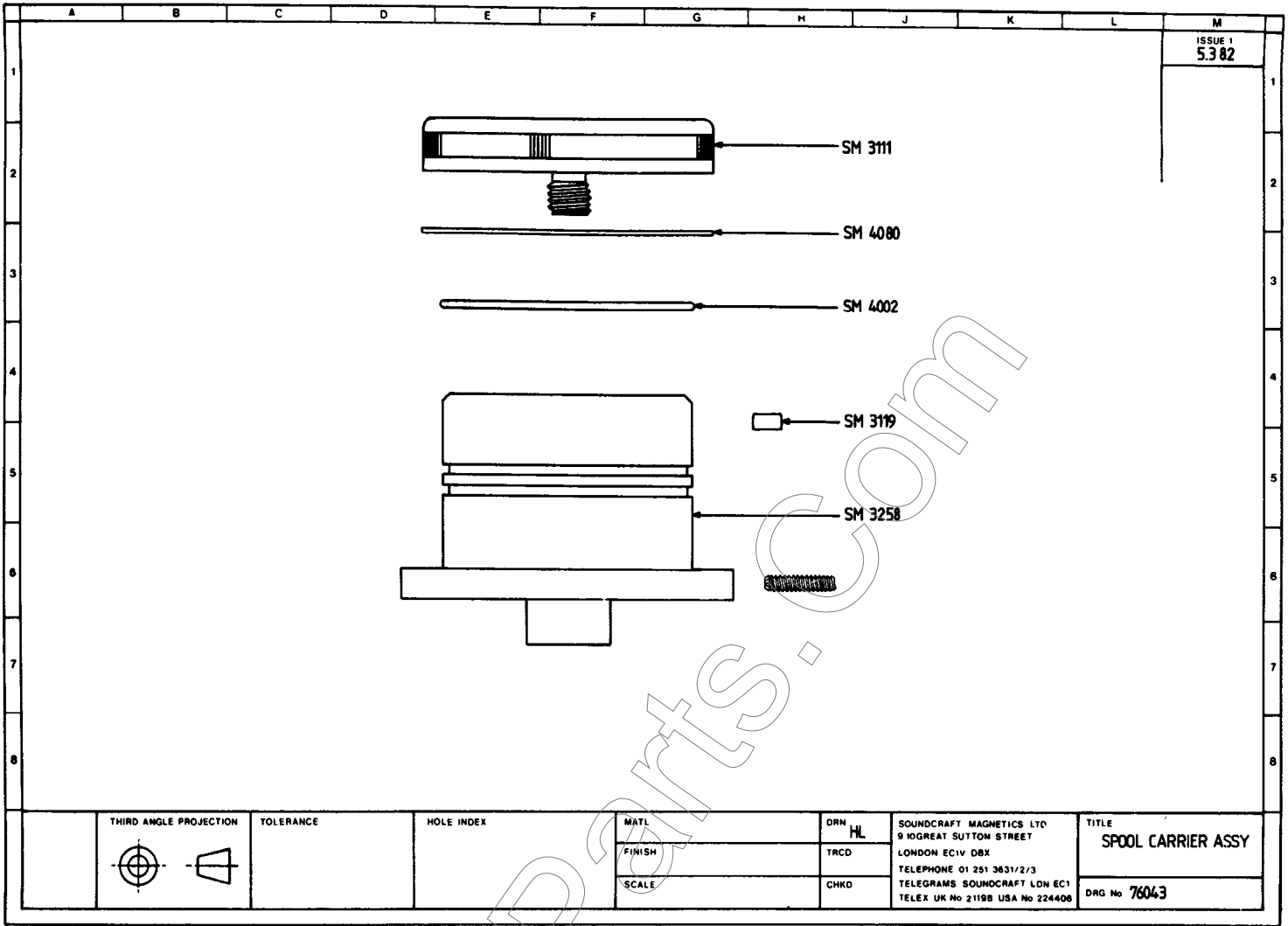

Spool Carrier Assy: (76043)

Ref. No.	Description	Qty. per Assy
SM 3111	Retainer - Tape Spool	1
SM 4080	Felt Washer	1
SM 4002	Rubber 'O' Ring	1
SM 3119	Drive Pin	1
SM 3258	Spool Carrier	1

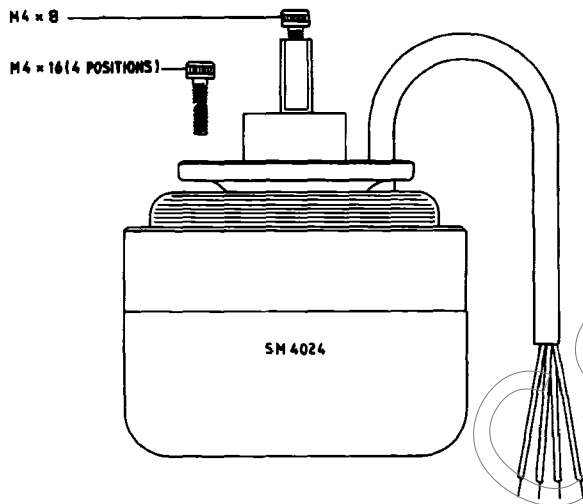

	TOLERANCE All imperial dimensions ± 0.01 All metric dimensions ± 0.25mm All angles ± 0.05° Unless otherwise stated	HOLE INDEX	MATL	DRN Brian	SOUNDCRAFT MAGNETICS LTD 6-8 GREAT BUTTON STREET LONDON EC1V 0BX TELEPHONE 01 251 3831/2/3 TELEGRAMS SOUNDCRAFT LDN EC1 TELEX UK No 21198 USA No 224408	TITLE SPOOL MOTOR ASSY
			FINISH	TRCD		
			SCALE	CHKD		DRG No 8087

SM
ISSUE 1
9.3.82

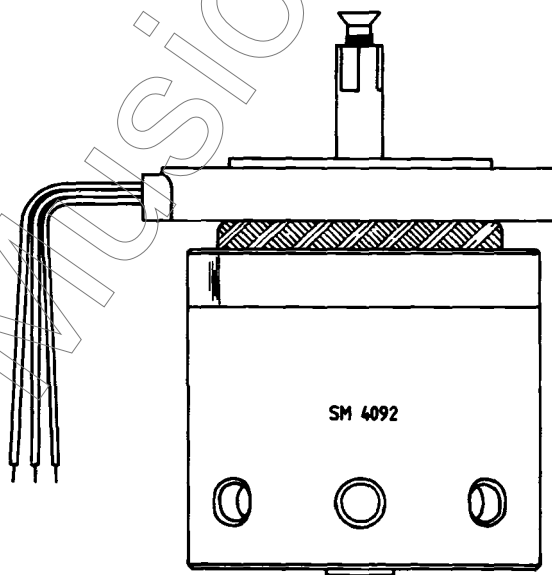

	TOLERANCE	HOLE INDEX	MATL	DRN HL	SOUNDCRAFT MAGNETICS LTD 9 10 GREAT BUTTON STREET LONDON EC1V 0BX TELEPHONE 01 251 3831/2/3 TELEGRAMS SOUNDCRAFT LDN EC1 TELEX UK No 21198 USA No 224408	TITLE 2" SPOOL MOTOR
			FINISH	TRCD		
			SCALE	CHKD		DRG No 76087

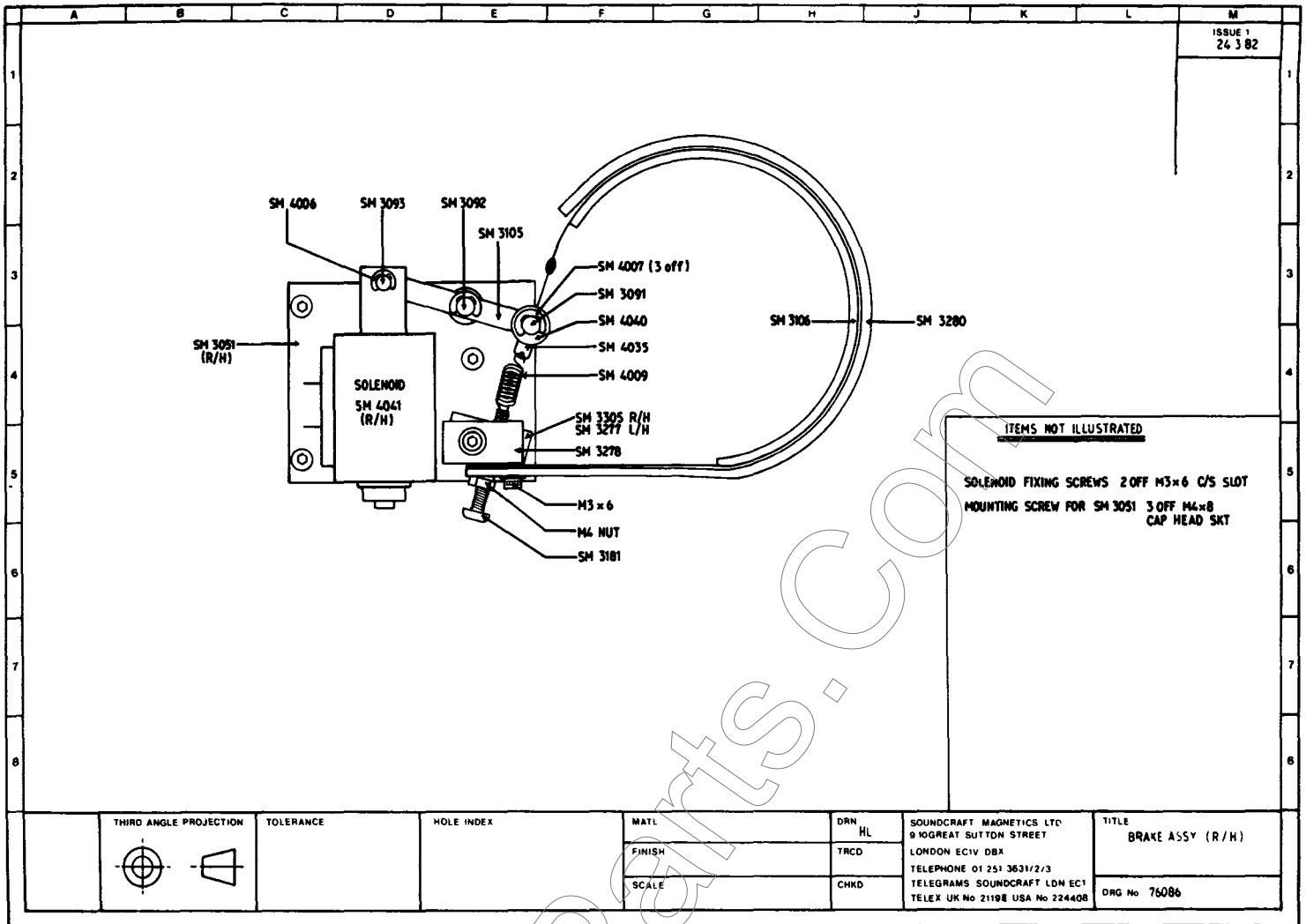

Brake Assy: R/H (76086)

Ref. No.	Description	Qty Per Assy:
SM 4006	'E' Clip	2
SM 3093	Plunger Pivot Pin	1
SM 3092	Brake Arm Pivot Post	1
SM 3105	Brake Actuating Arm)	1
SM 3091	Brake Band Pivot Post) Assembly	1
SM 4035	Spring Anchor	1
SM 4040	2 B A Washer	1
SM 4007	'E' Clip	2
SM 4009	Arm Return and Adjust Spring	1
SM 3106	Brake Band	1
SM 3280	Brake Band Guide	1
SM 3278	Brake Adjust Block Secondary	1
SM 3277	Brake Adjust Block Main L/H	1
SM 3305	Brake Adjust Block Main R/H	1
SM 4041	Solenoid R/H	1
SM 4042	Solenoid L/H	1

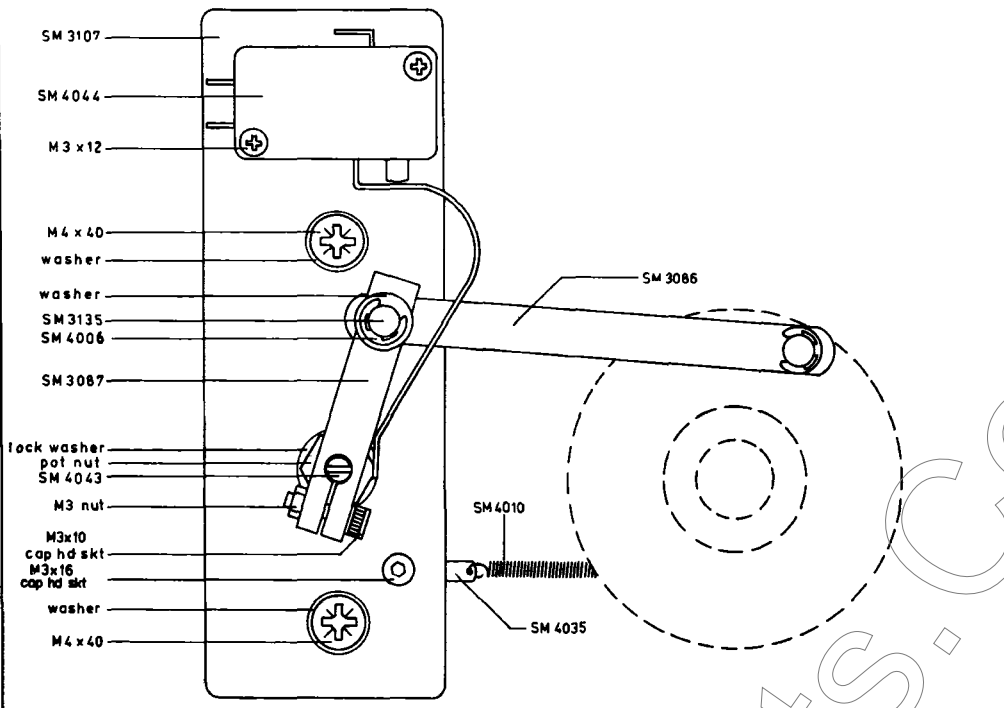

PARTS NOT ILLUSTRATED

SM4007 'E' Clip - upper retainer for pin SM3135
 SM4043 250K Servo pot
 SM4037 Hexagon spacer M3x10 2off (Micro switch mount)
 SM3125 Pot mount plate support pillars 2off
 M3 Nut Spring tag retain 3off
 M3x6 Pan head 'POZI' - Hex spacer retain upper 2off

	THIRD ANGLE PROJECTION	TOLERANCE All Imperial dimensions ± 0.01 All metric dimensions ± 0.25mm All angles ± 0.50° Unless otherwise stated	HOLE INDEX	MAT'L	DRN	SOUND-CRAFT MAGNETICS LTD 146 GREAT BUTTON STREET LONDON EC1V 0BX TELEPHONE 01 281-2631/2/3 TELEGRAMS: SOUND-CRAFT LON EC1 TELEX: UK No. 21188 USA No. 224488	TITLE TENSION CONTROL AND AUTO STOP MECH DRG No. 8088
				F-NISH	TRCD		
				SCALE	CHKD		

Tension Control & Auto Stop Mech: (8088)

Ref. No.	Description	Qty per Assy
SM 3107	Plate - Pot Mount	1
SM 4044	Micro-switch	1
SM 3135	Pin - link pivot	1
SM 4006	'E' Clip	2
SM 3087	Arm - Pot Link	1
SM 4043	Pot - Tension control 250K	1
SM 3086	Arm - Pulley Link	1
SM 4010	Spring - Linkage Return	1
SM 4035	Tag - Spring Retain	1
SM 4037	Spacer - Hexagon M3 x 10	2
SM 3125	Pillar - Pot Mount Plate Support	2

Back Tension Disc Assy: (8089)

Part No.	Description	Qty per Assy
SM3126	Cap - Flutter Roller	1
SM3112	Flutter Roller	1
SM3145	Guide - Tape Tension	1
SM4018	Washer - Thrust	1
SM3117	Shaft - Flutter Roller	1
SM3096	Disc - Back Tension	1
SM4018	Washer - Thrust	1
SM3116	Shaft - Back Tension Bearing	1
SM3115	Housing - Back Tension Bearing	1

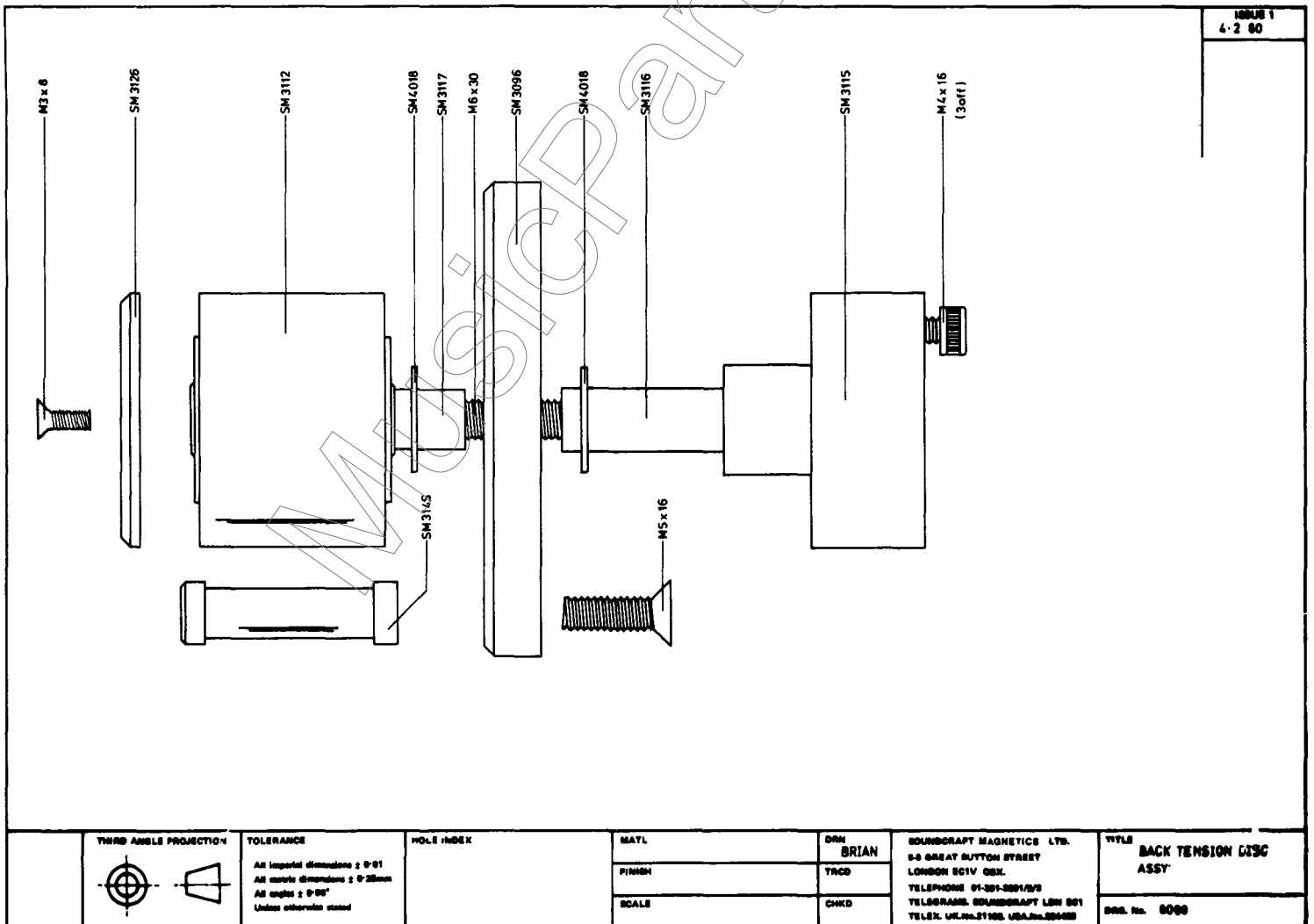

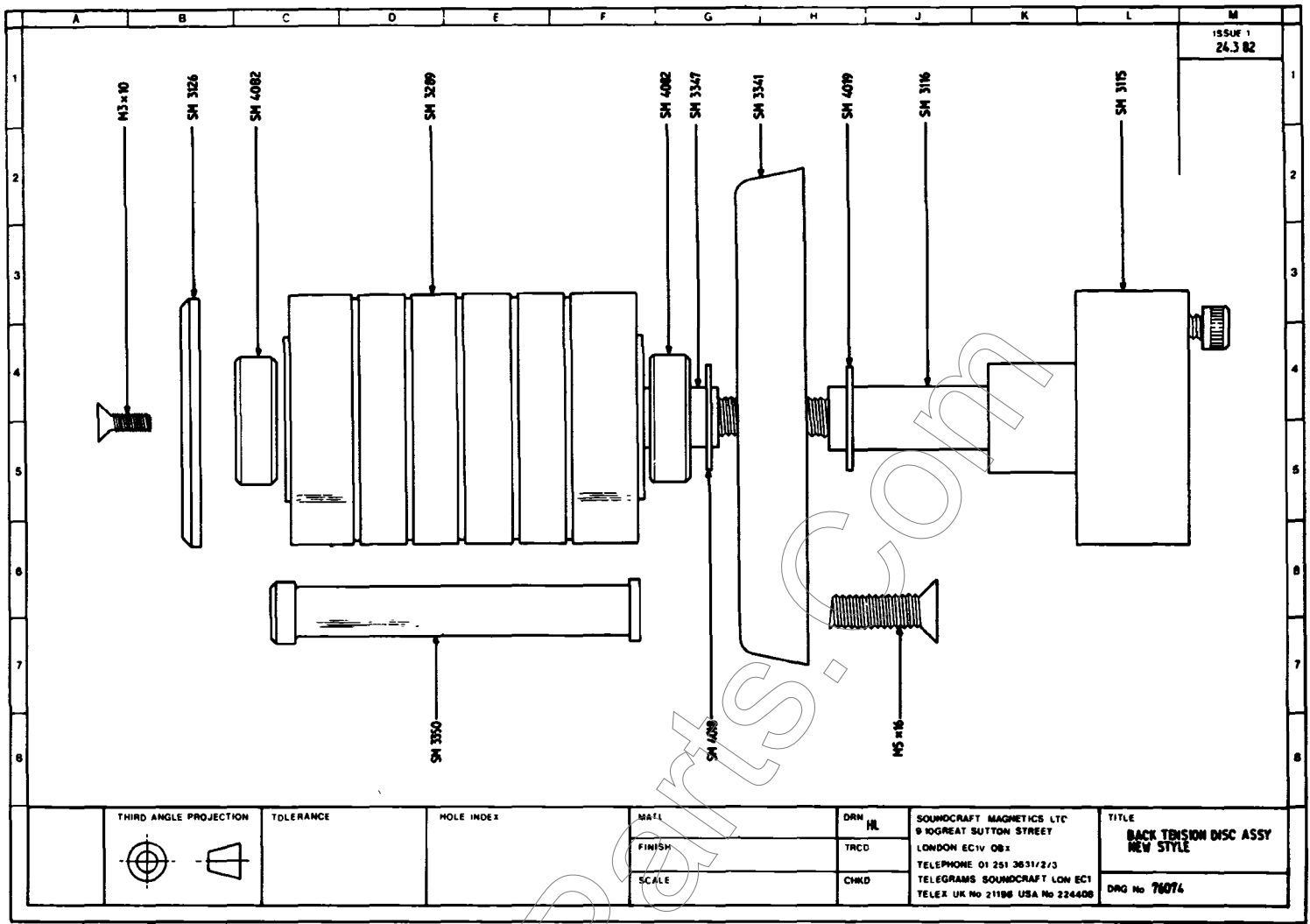

Back Tension Disc Assy: (New Style)
(76074)

Ref. No.	Description	Qty per Assy
SM 3126	Cap - Flutter Roller	1
SM 4082	Ballrace	2
SM 3350	Guide - Tension Arm	1
SM 3289	Flutter Roller (Ballrace Type)	1
SM 3347	Shaft - Flutter Roller Bearing	1
SM 4018	Thrust Washer - Upper	1
SM 4019	Thrust Washer - Lower	1
SM 3341	Disc - Back Tension	1
SM 3116	Shaft - Back Tension Bearing	1
SM 3115	Bearing - Back Tension	1

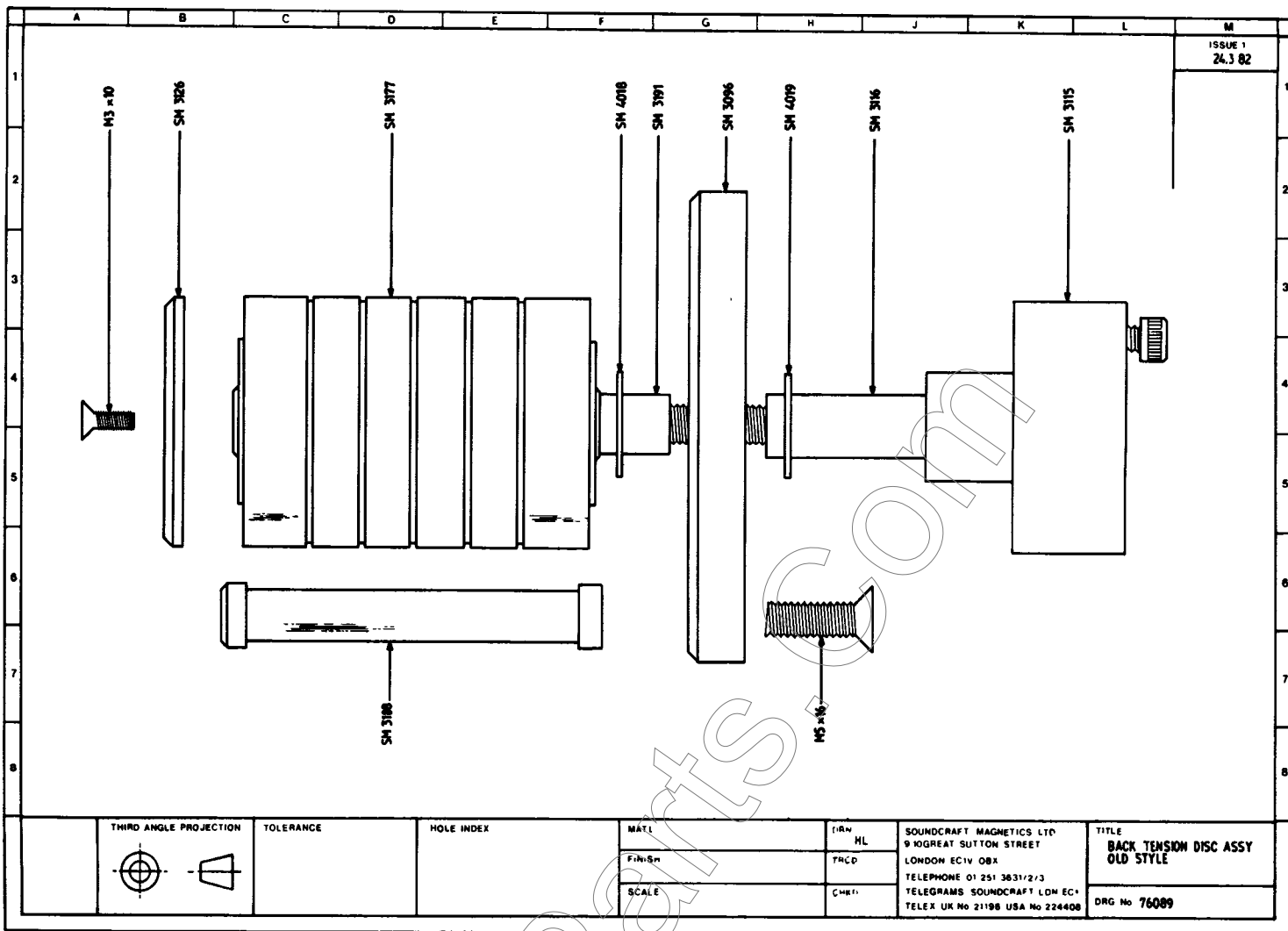

Back Tension Disc Assy: (Old Style)
(76089)

Ref. No.	Description	Qty. per Assy
SM 3126	Cap - Flutter Roller	1
SM 3188	Guide - Tension Arm	1
SM 3177	Flutter Roller (Inc. Bushes)	1
SM 4018	Thrust Washer - Upper	1
SM 4019	Thrust Washer - Lower	1
SM 3191	Shaft - Flutter Roller	1
SM 3096	Disc - Back Tension	1
SM 3116	Shaft - Back Tension Bearing	1
SM 3115	Bearing - Back Tension	1

Back Tension Pulley Assy: (8090)

Part No:	Description	Qty Per Assy
SM3093	Pin: Pulley Link Arm	1
SM4006	'E' Clip	1
SM3084	Pulley	1
SM4019	Washer - Thrust	1
SM4036	Pin - Spring Anchor	1

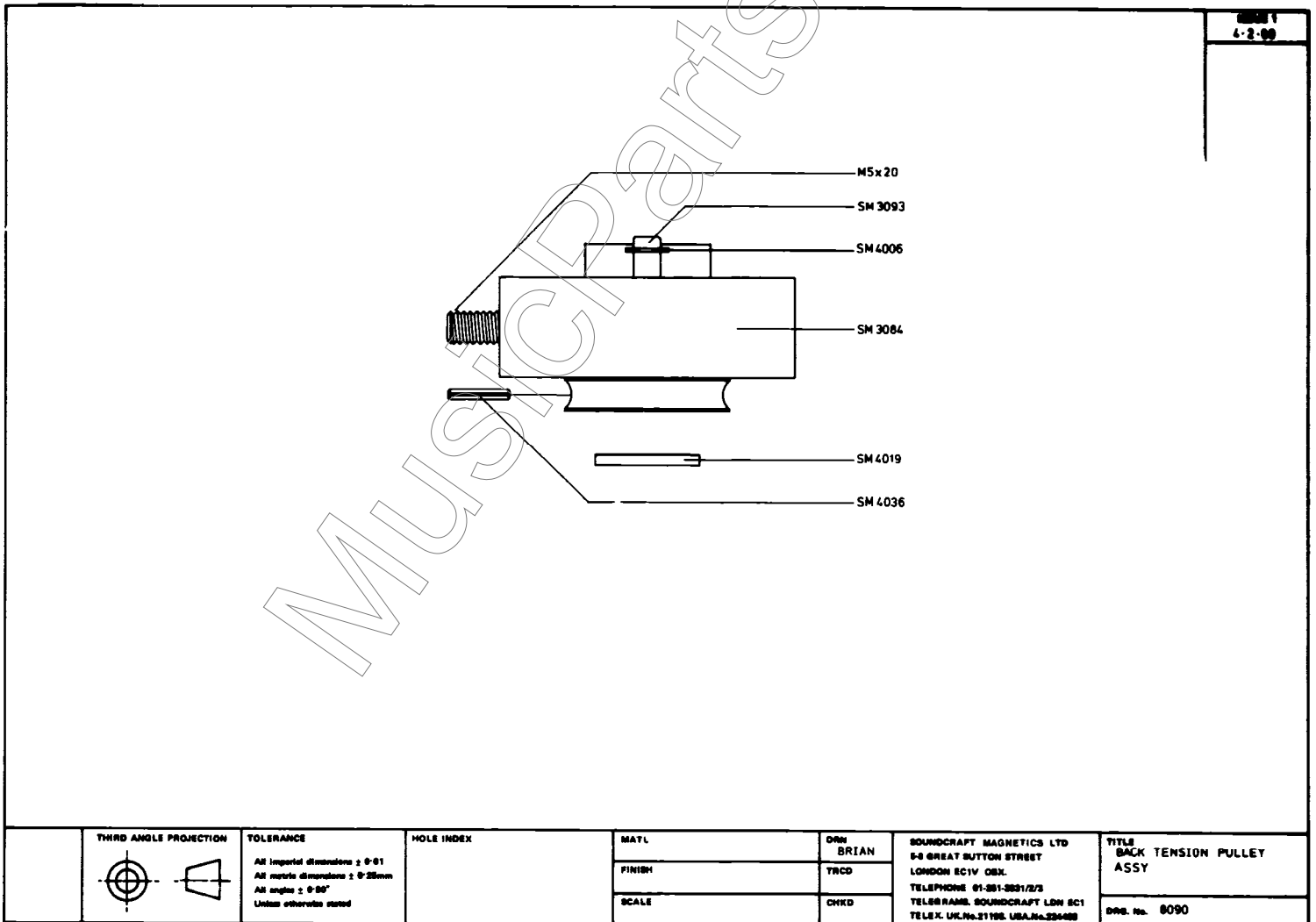

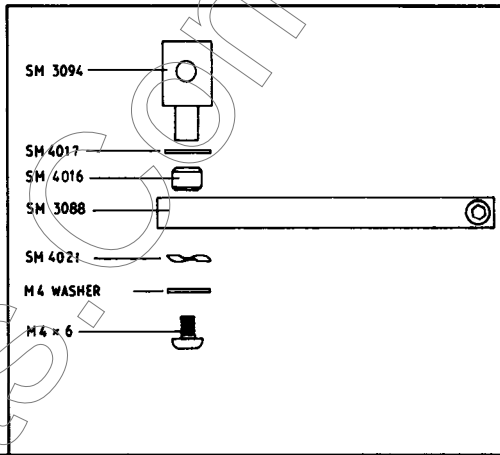
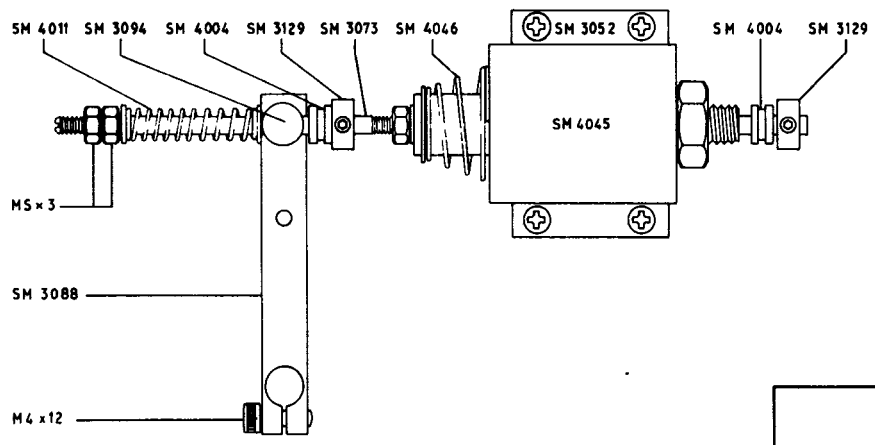

<p>THIRD ANGLE PROJECTION</p>	<p>TOLERANCE</p> <p>All imperial dimensions ± 0.01 All metric dimensions ± 0.25mm All angles ± 0.50° Unless otherwise stated</p>	<p>SOLE INDEX</p>	MATL	DRN	<p>SOUNDCRAFT MAGNETICS LTD 5-8 GREAT BUTTON STREET LONDON EC1V 0BX TELEPHONE 01 251 3831/2/3 TELEGRAMS: SOUNDCRAFT LON EC1 TELEX UK No.21108, USA No.234408</p>	<p>TITLE PINCH SOLENOID MECH ASSY</p> <p>ORG No 8091</p>	
			FINISH	Brian			TRCD
			SCALE				CHKD

1179K

Pinch Solenoid Mech: Assy: (8091)

Ref. No.	Description	Qty per Assy
SM 4011	Spring - Pinch Tension	1
SM 3094	Fulcrum Post	1
SM 4004	Control Arm Damper	2
SM 3129	Adjustment Collar	2
SM 3073	Control Rod	1
SM 4046	Spring - Plunger Return	1
SM 4045	Solenoid	1
SM 3052	Mount Plate	1
SM 3088	Control Arm	1
SM 4017	Thrust Washer	1
SM 4016	Thrust Bush	1
SM 4021	Pre-Load Washer	1

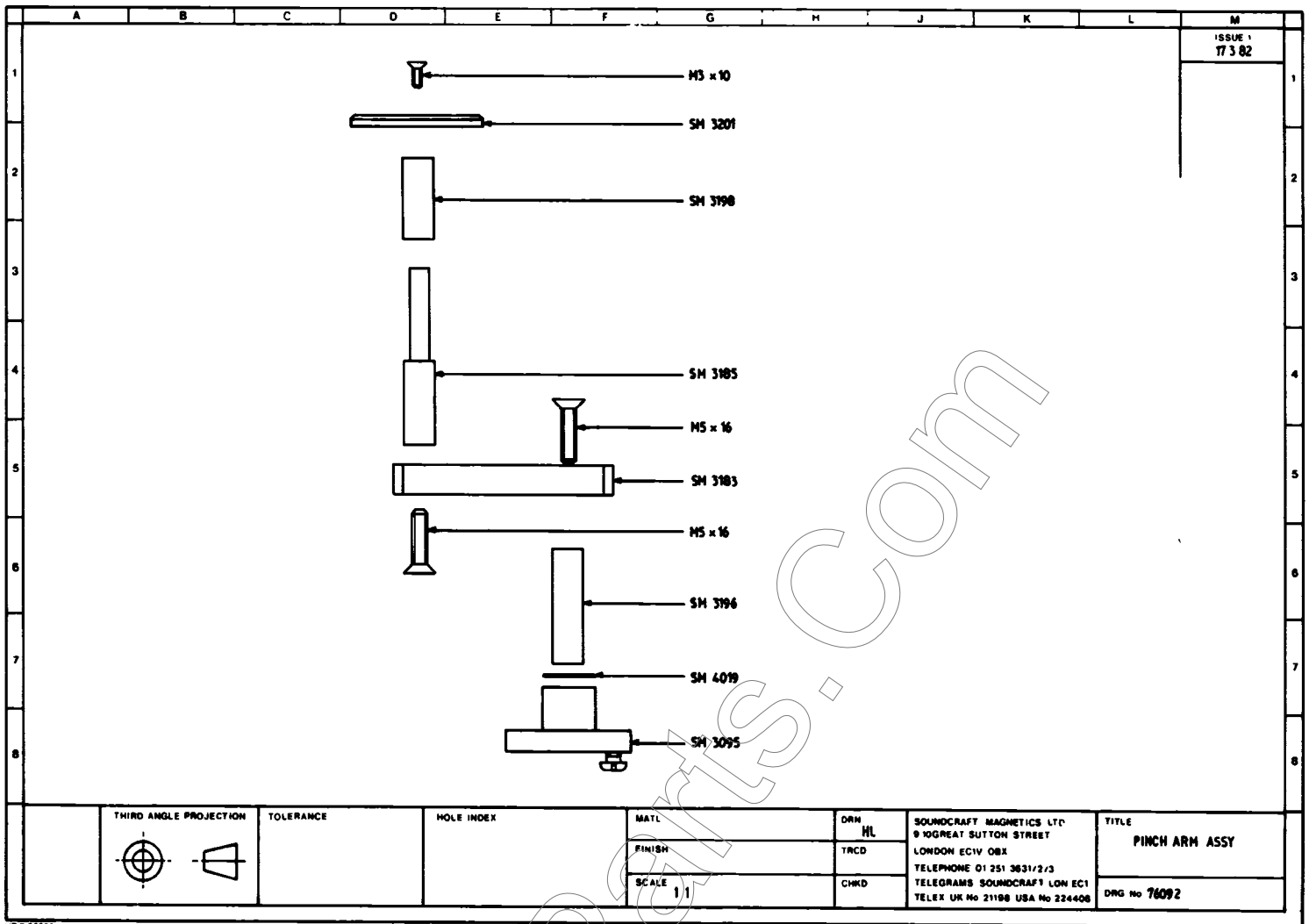

762 Pinch Arm Assy: (76092)

Ref. No.	Description	Qty. per Assy
SM 3201	Cap - Pinch Roller	1
SM 3198	Retaining Collar	1
SM 3185	Post - Pinch Bearing	1
SM 3183	Pinch Roller Carrier Arm	1
SM 3196	Pinch Arm Shaft	1
SM 4019	Thrust Washer	1
SM 3095	Bearing Housing	1

For 1" machines

SM 3198 Replaced by SM 3123
SM 3185 Replaced by SM 3102

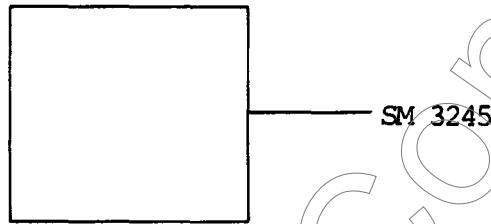
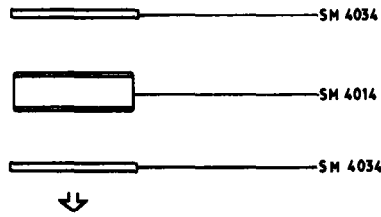

			WORLD WIDE	DATE	BY	SOUNDCRAFT MAGNETICS LTD 5-8 GREAT SUTTON STREET LONDON EC1 0RH TELEPHONE 01 251 3431/2/3 TELEGRAMS SOUNDCRAFT LON EC1 TELEX UK No. 21198, USA No. 01-2303	WFLS PINCH ROLLER ASSY: SER. No. 8093
				1980	Brian		

Pinch Roller Assy (8093)

Ref. No.	Description	Qty per Assy
SM 4034	Circlip - Ballrace Retainer	2
SM 4014	Ballrace	1
SM 3245	Pinch Roller	1

Head Shield Assy (8012)

Part No.	Description	Qty Per Assy
SM3134	Body - Head Shield	1
SM3133	Pin - Head Shield	1
SM3108	Screw - Head Shield	1
	Screw - M4 x 4 Skt Set Screw	1

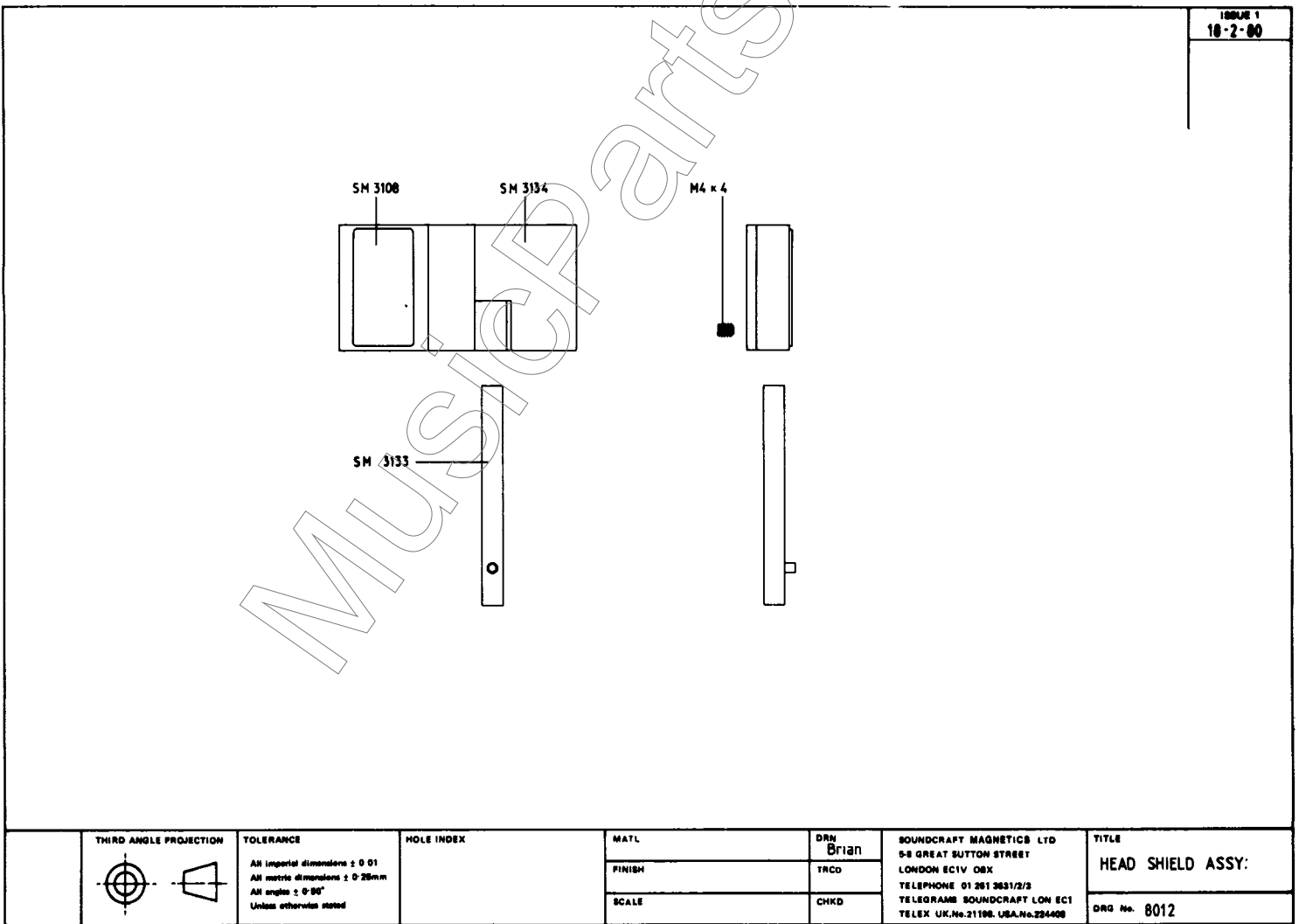

M
ISSUE 1
5-1-81
2-2-81

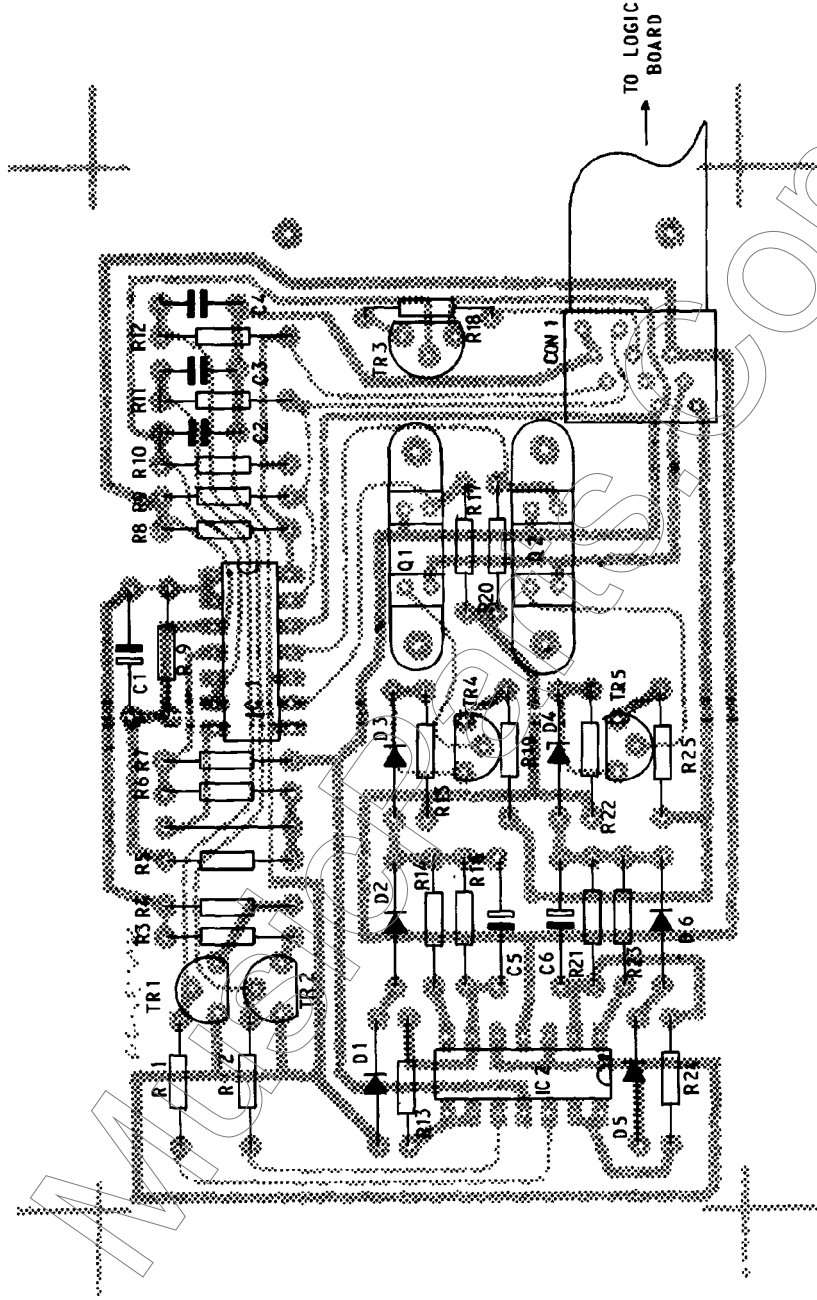

TITLE
MOTION SENSE BOARD
Mk II (AUTO)
DRG No SM 76097

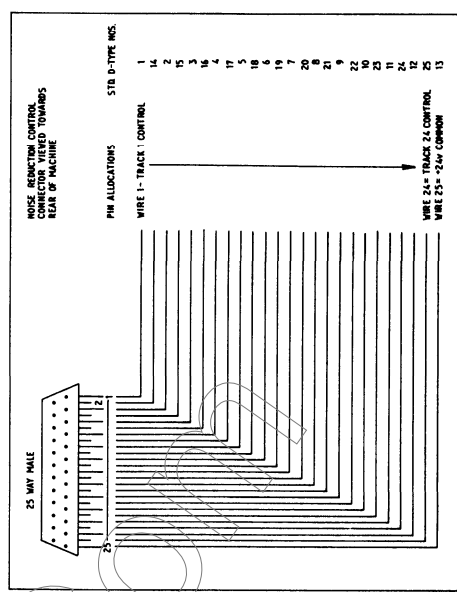
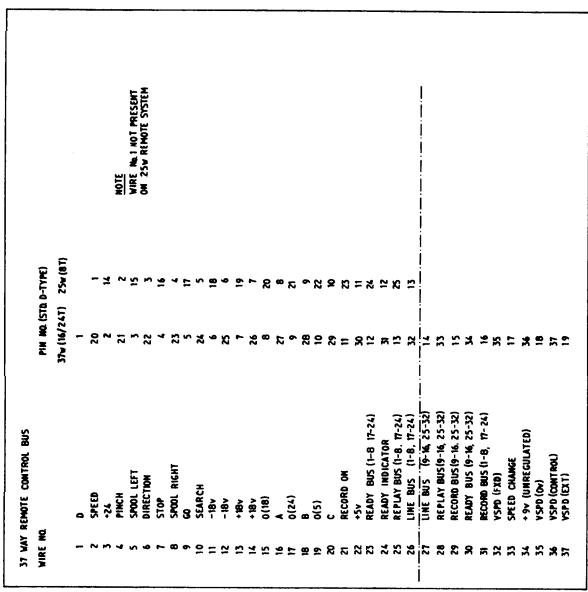

TITLE
MUSE REMOTION
INTERFACE BOARD
TYPE 2

SOUNDCRAFT ELECTRONICS LTD
5-8 GREAT SUTTON STREET
LONDON EC1V 0BB.
TELEPHONE: 01-251-3811/2/3
TELEGRAMS: SOUNDCRAFT LON EC1
TELEX: UK No. 21988. USA No. 2284608

DWG. No. SH 7004

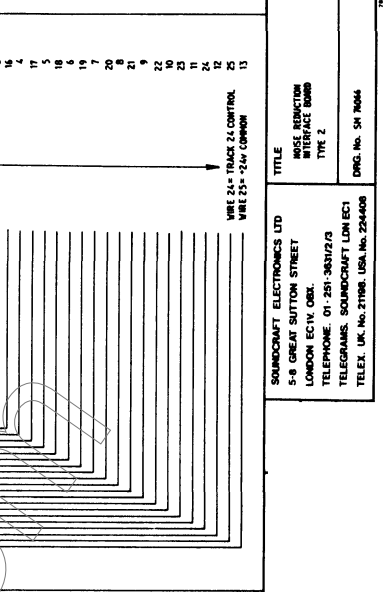
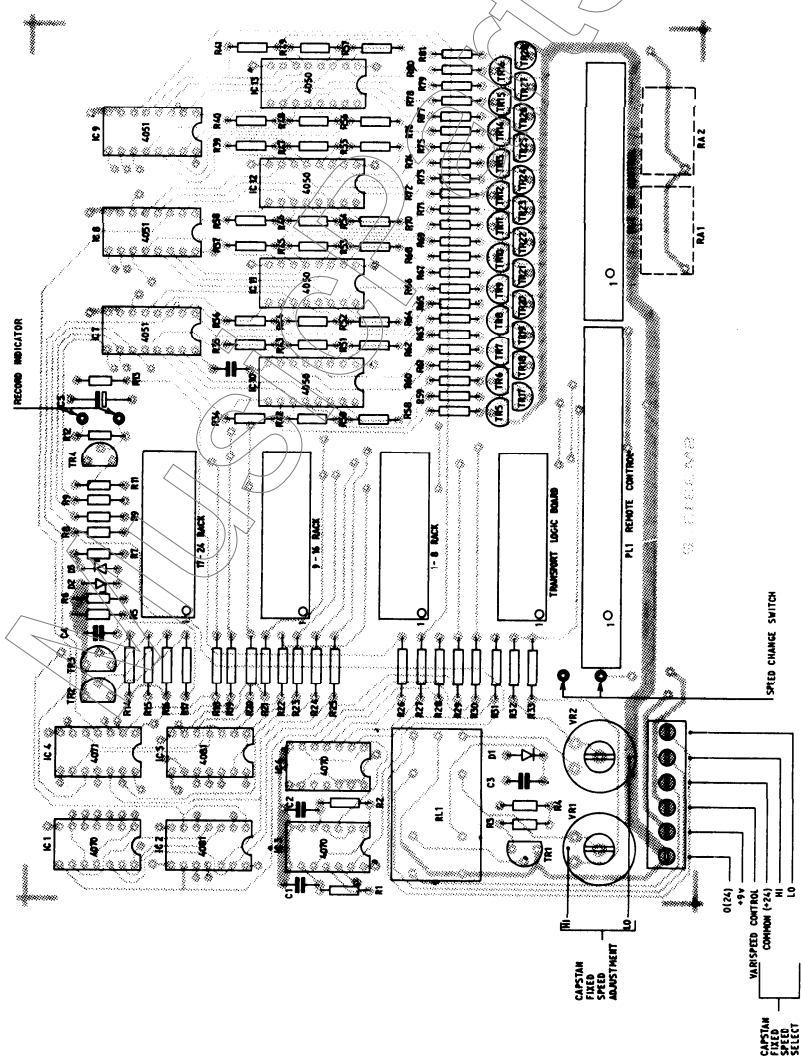

1

M
ISSUE 1
5-1-81

2-2-2-81

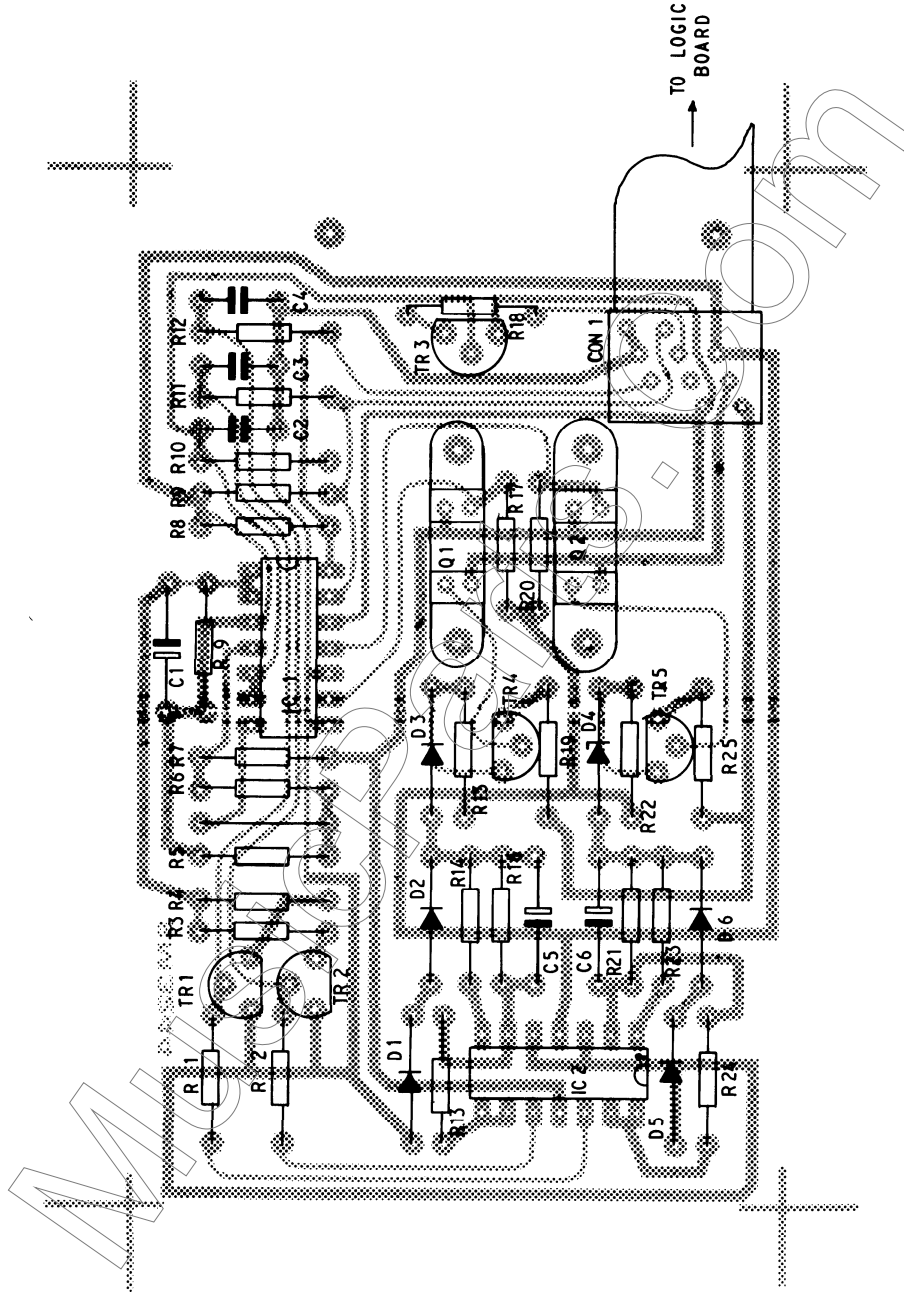

TITLE
MOTION SENSE BOARD
MK II (AUTO)
DRG No SM 76097

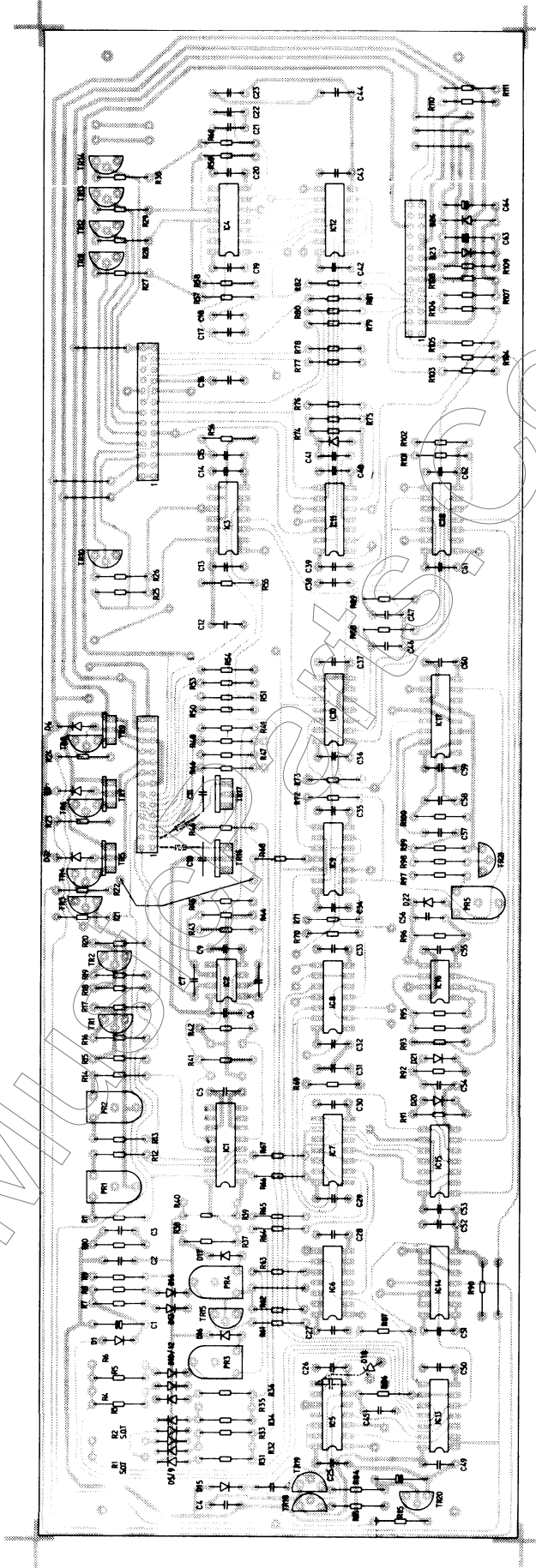

TITLE	TRANSPORT LOGIC BOARD COMPONENT LAYOUT
DRWG. No.	SH 76032

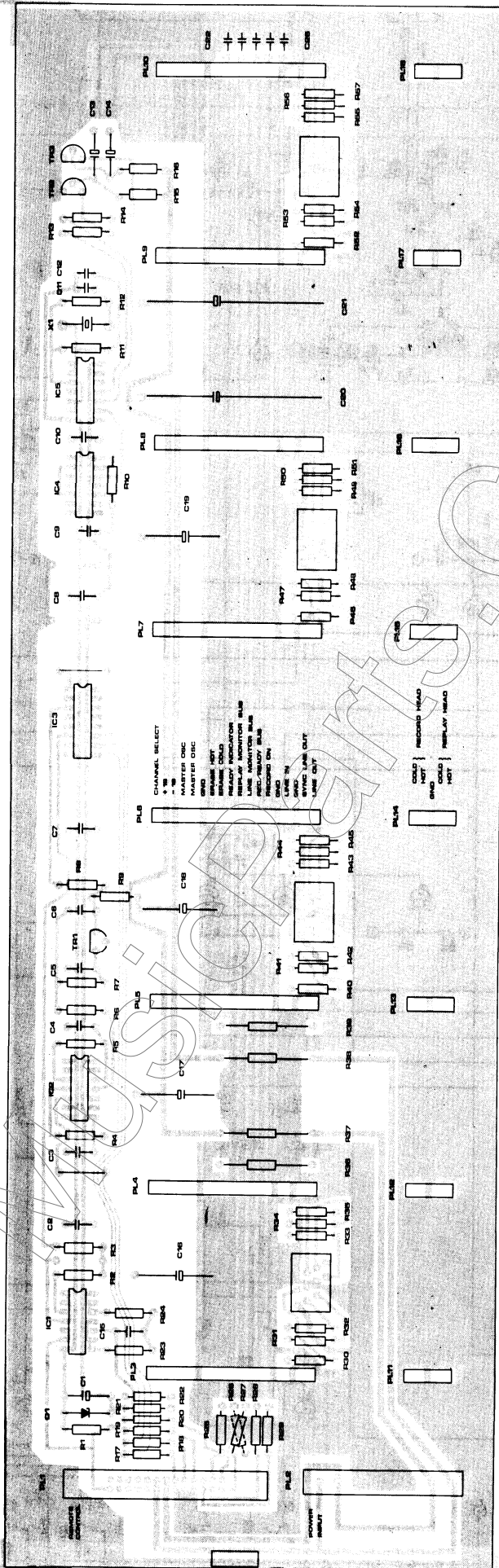

AUDIO RACK MOTHER BOARD SM 8063

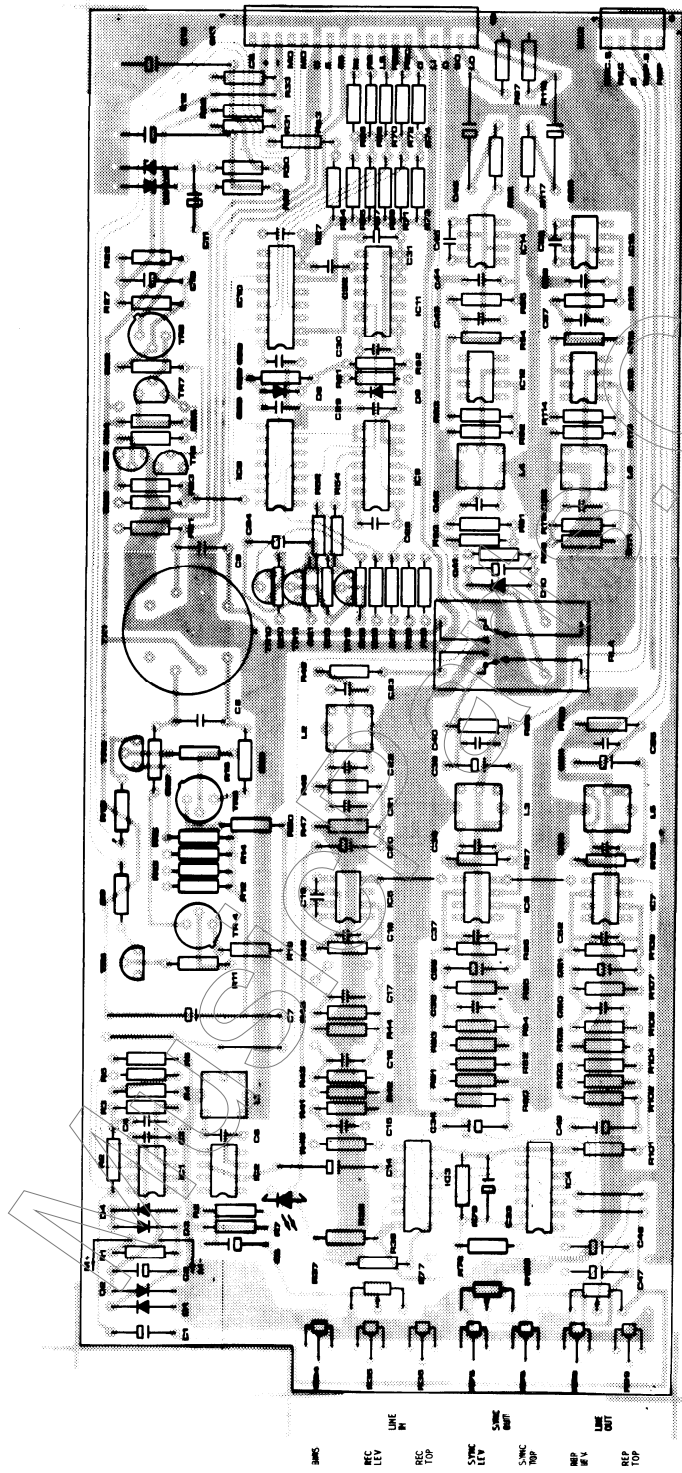

TITLE	AUDIO CHANNEL
COMPONENT LAYOUT	
DRG. No.	SM 8035

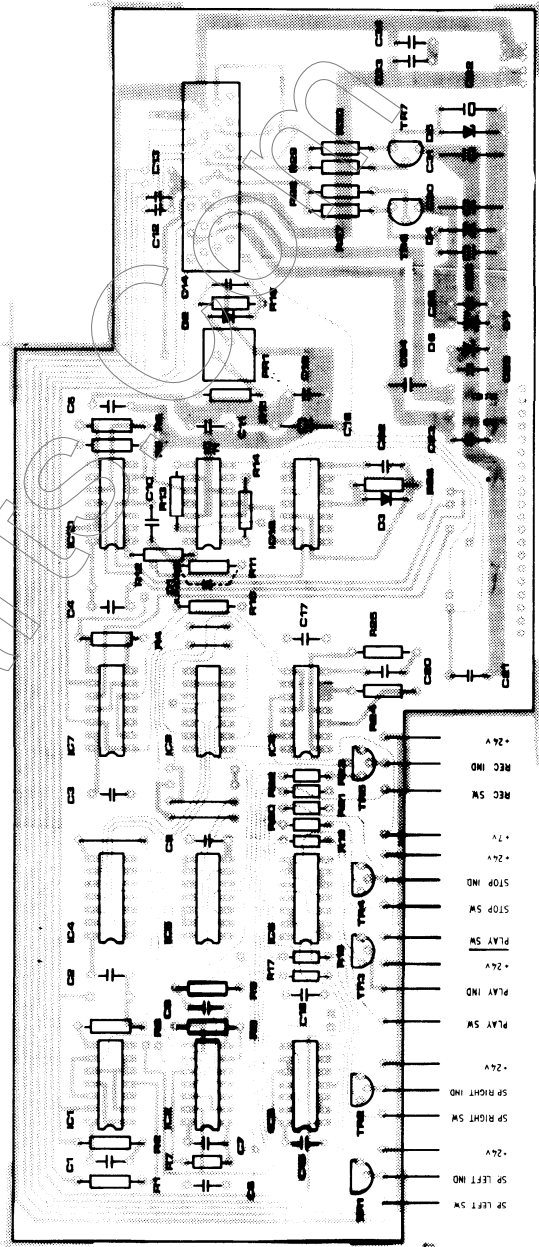
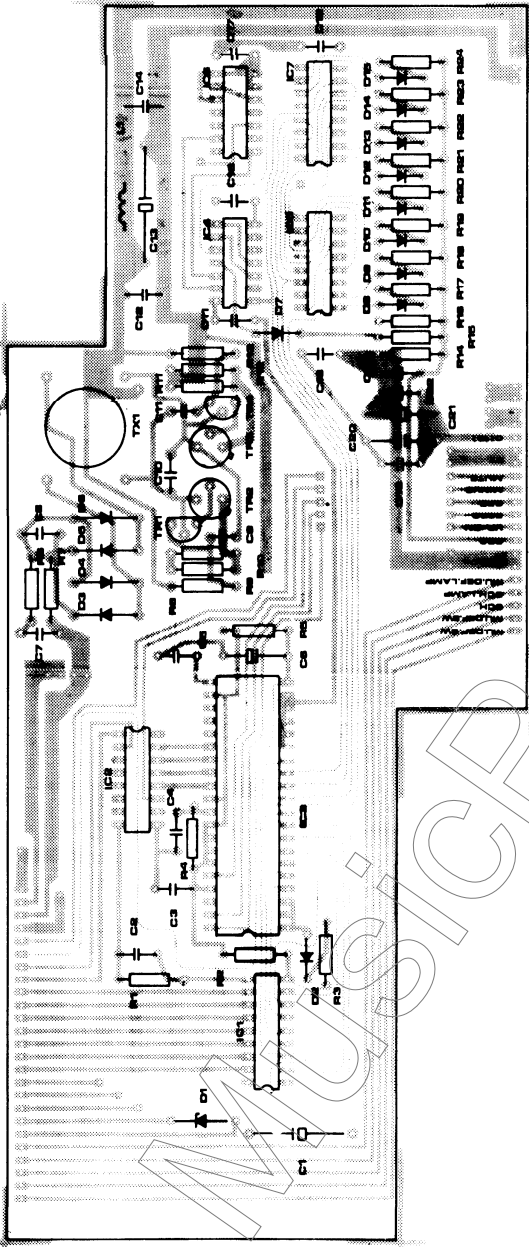

SOUND CRAFT LTD
 5-8 GREAT SMITH STREET
 LONDON EC1 0BA
 TELEPHONE: 01-251-3631/2/3
 TELEGRAMS: SOUND CRAFT LDM EC1
 TELEX: UK No. 21196 USA No. 01-2203

TITLE
 REMOTE CONTROL
 TRANSPORT SECTION
 Dwg. No. **SM 8038**
8039

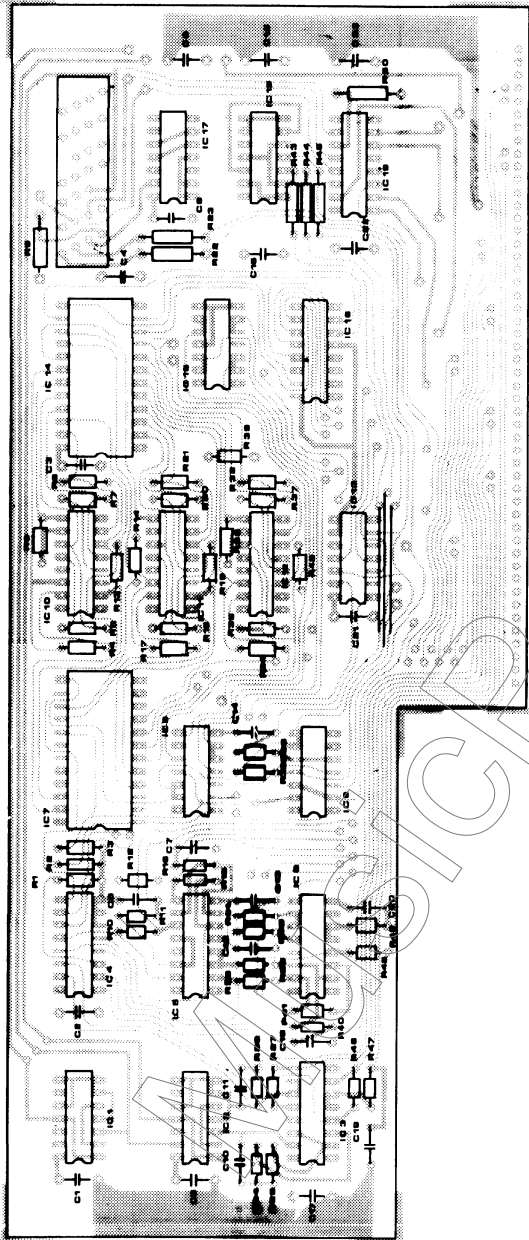

5.H 8037

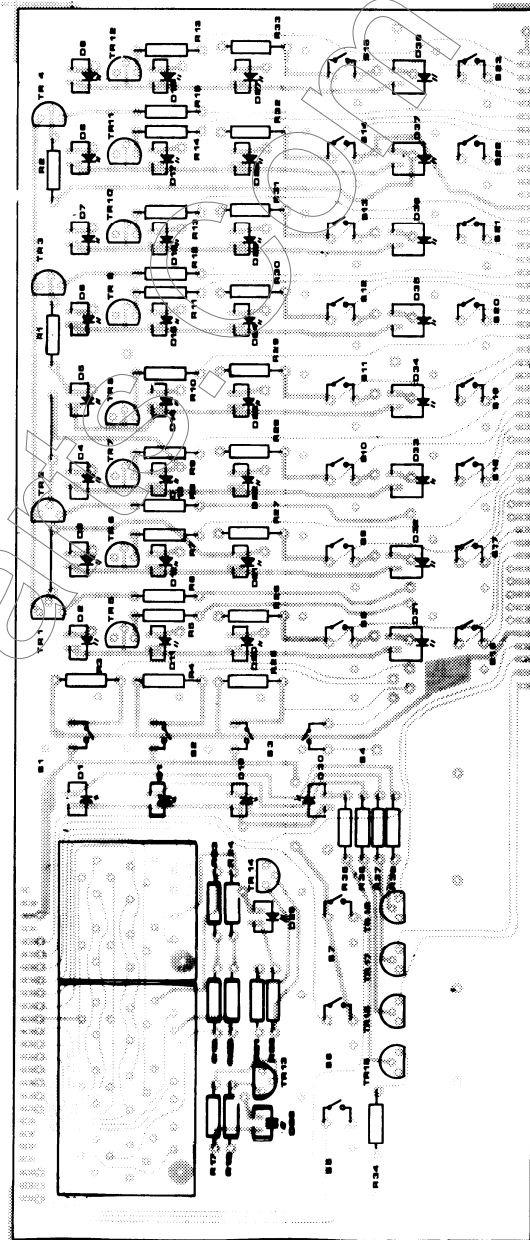

5.H 8036

SOUND CRAFT MAGNETICS LTD.
 5-6 GREAT SUTTON STREET
 LONDON EC 1V 0BX
 TELEPHONE 01-251-3631/2/3
 TELEGRAMS SOUND CRAFT LDN EC1
 TELEX UK No. 21198 USA No. 01-2203

TITLE REMOTE CONTROL
 SWITCH & AUDIO SECTION
 DRG. No. **SM 8036**
8037

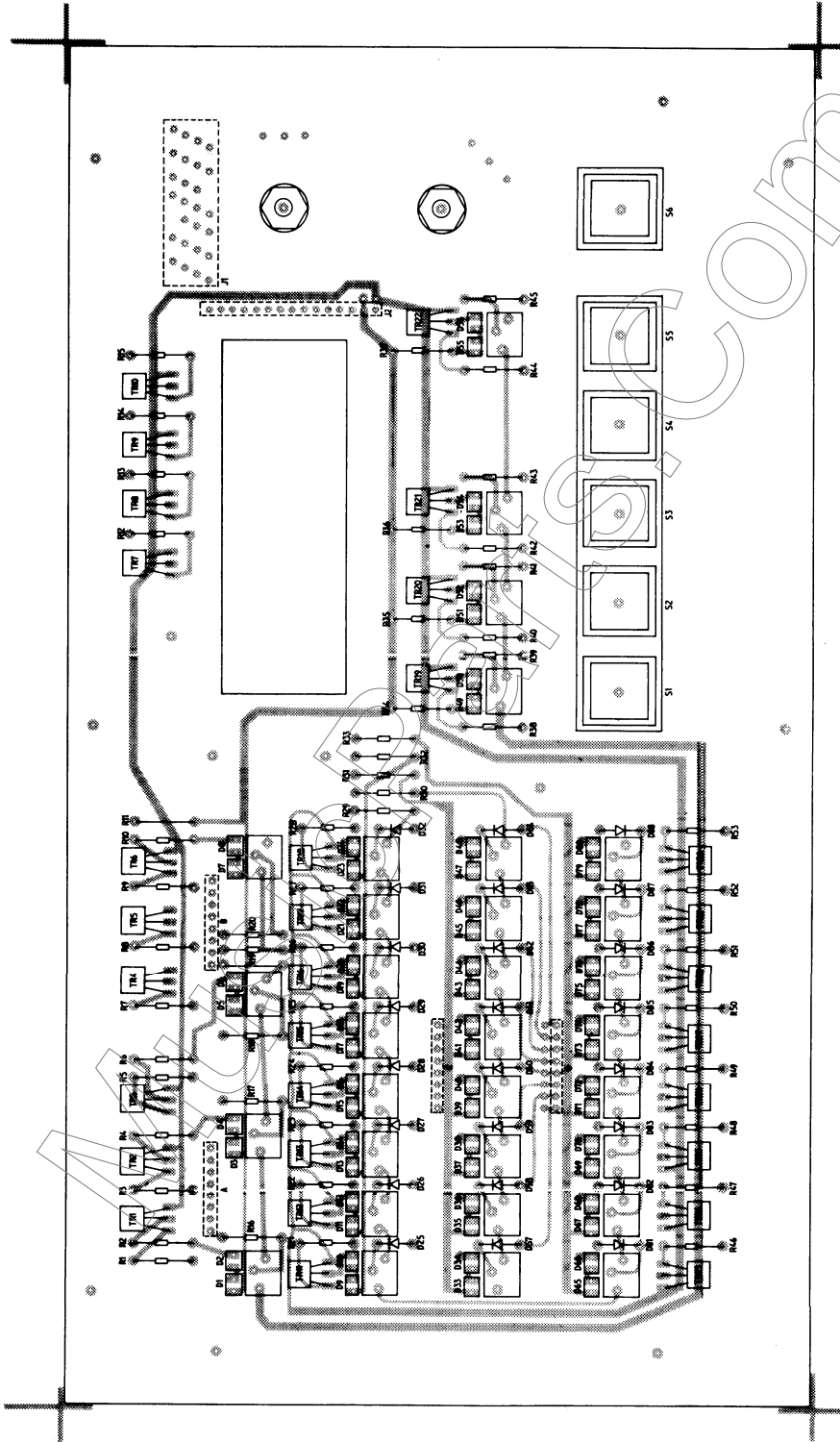

TITLE: STANDARD REMOTE CONTROL
 SWITCH BOARD
 COMPART LAYOUT
 DRWG. NO. SH 71034

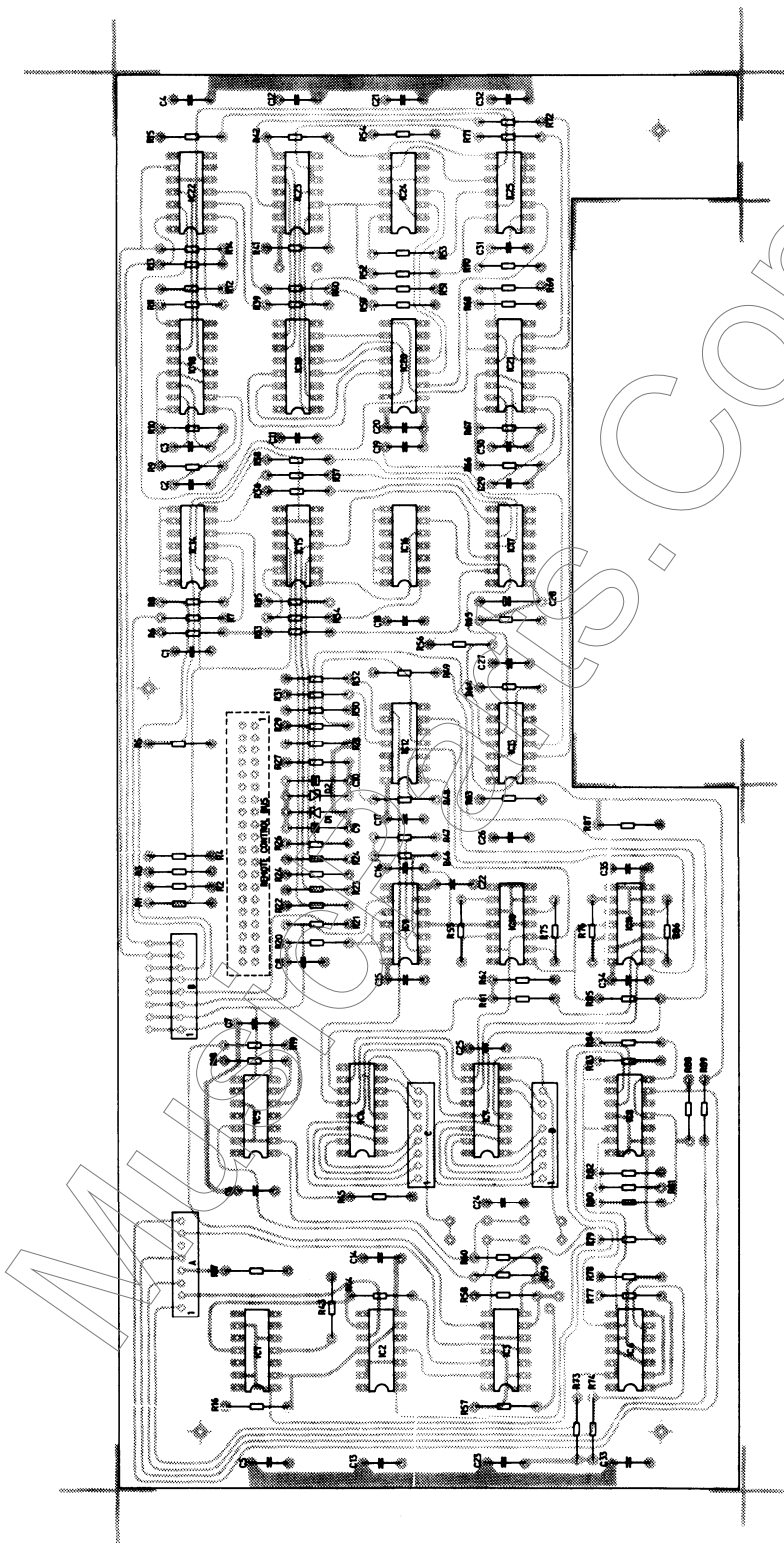

TITLE	STANDARD REMOTE CONTROL PCB 3 CHANNEL CONTROL BOARD COMPONENT LIST
ENCL. NO.	34 7039

1/22

M
ISSUE 1
23.2.82

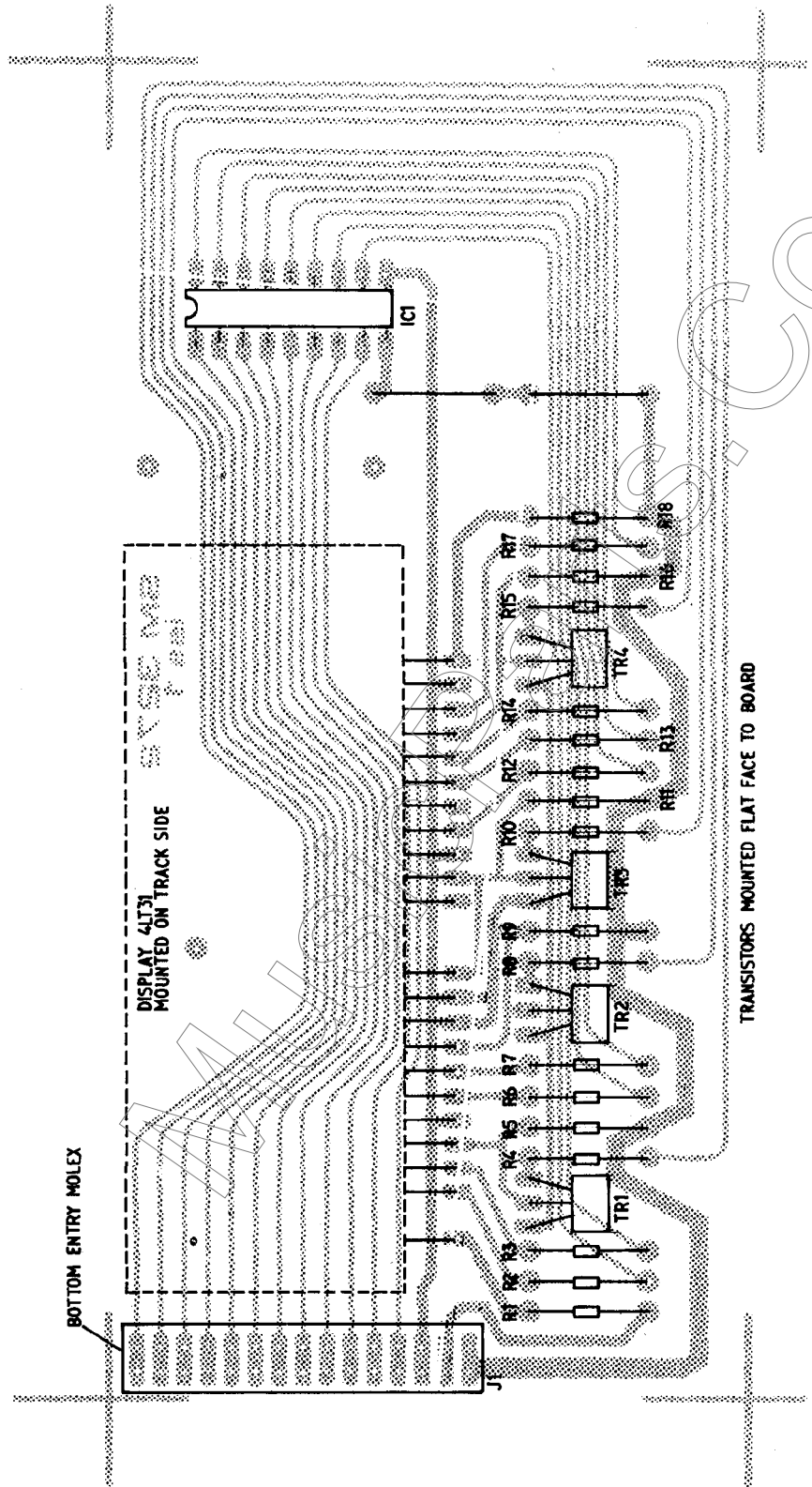

TITLE	STANDARD REMOTE CONTROL
PCB 2	DISPLAY BOARD COMPONENT
LAYOUT	
DRG. No.	SM 76037

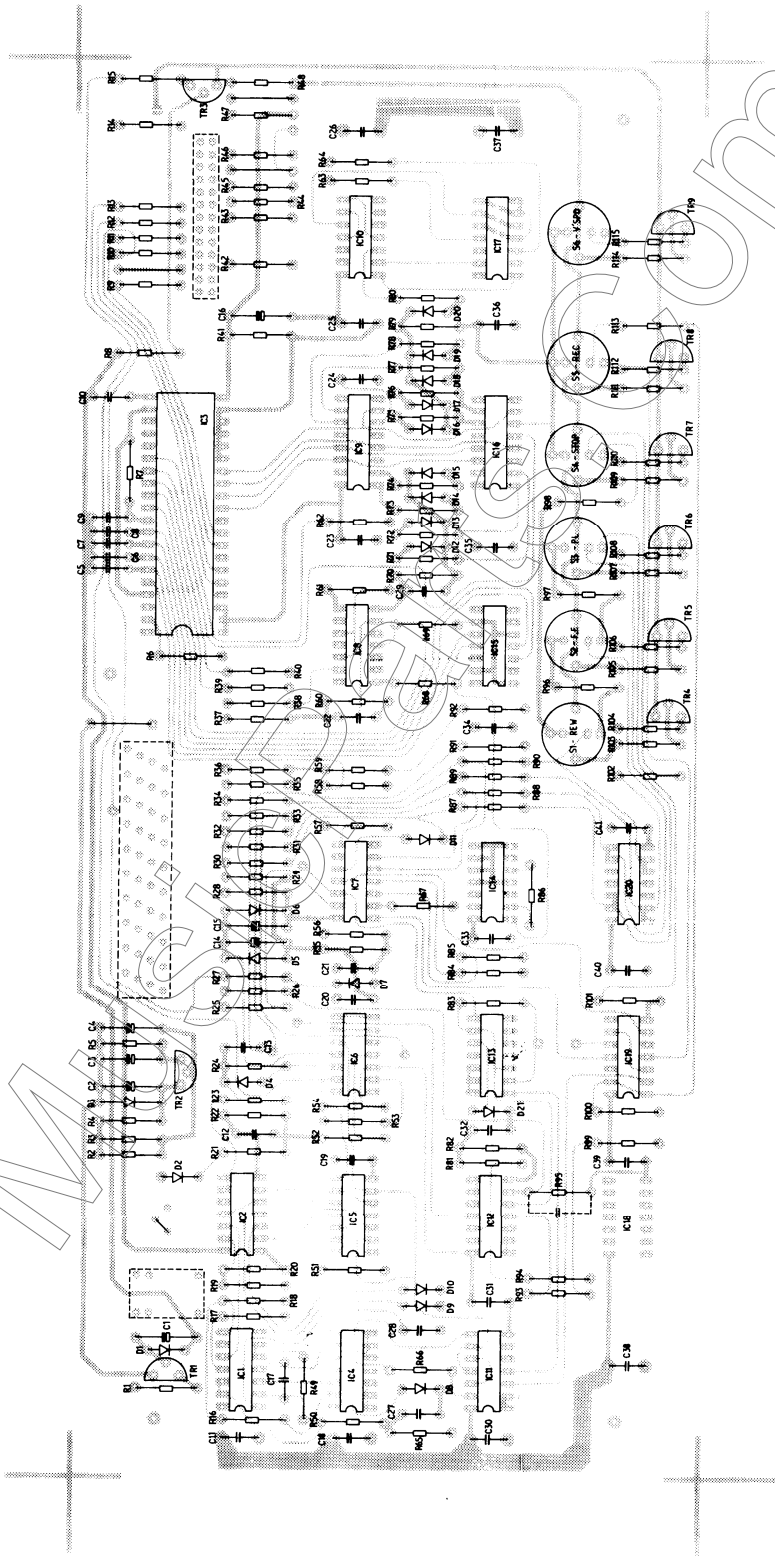

TITLE	REMOTE CONTROL
DESIGNED BY	...
DATE	...
DRG. No.	5M 76079

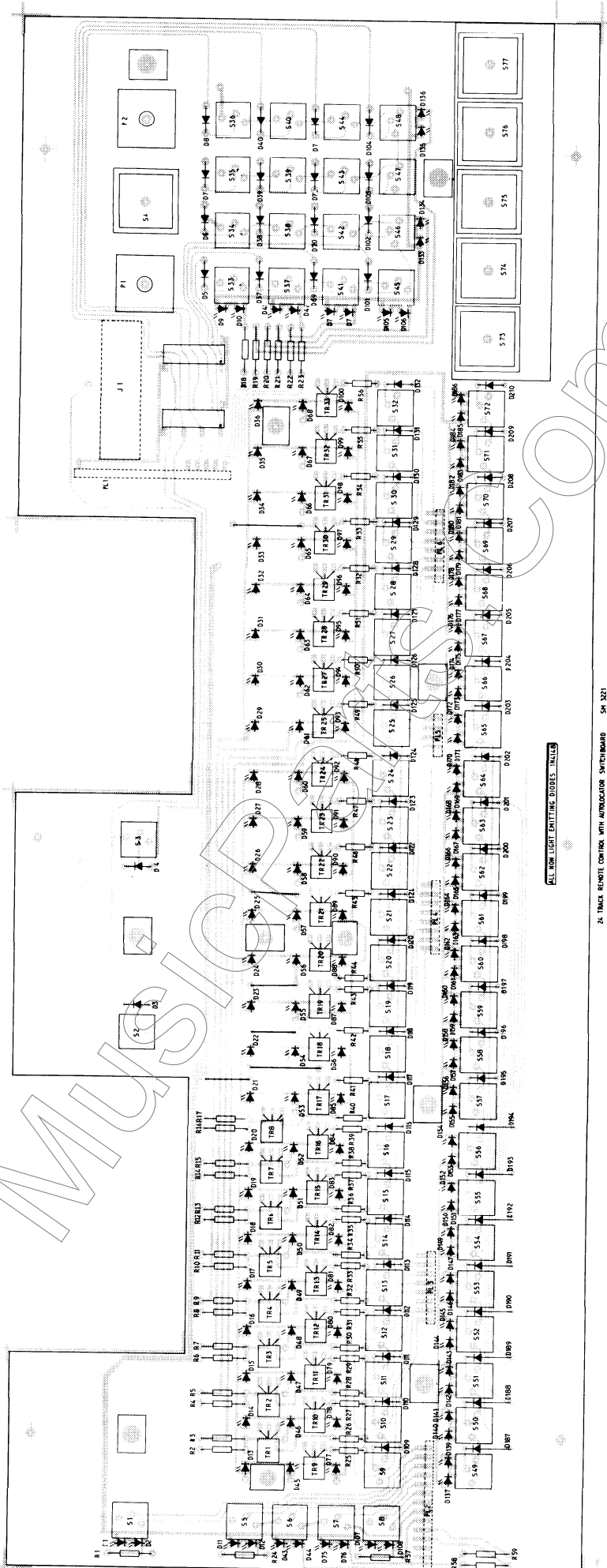

ALL NON LIGHT EMITTING DIODES: TR1-25

24 TRACK REMOTE CONTROL WITH AUTOMATIC SWITCHBOARD SH 321

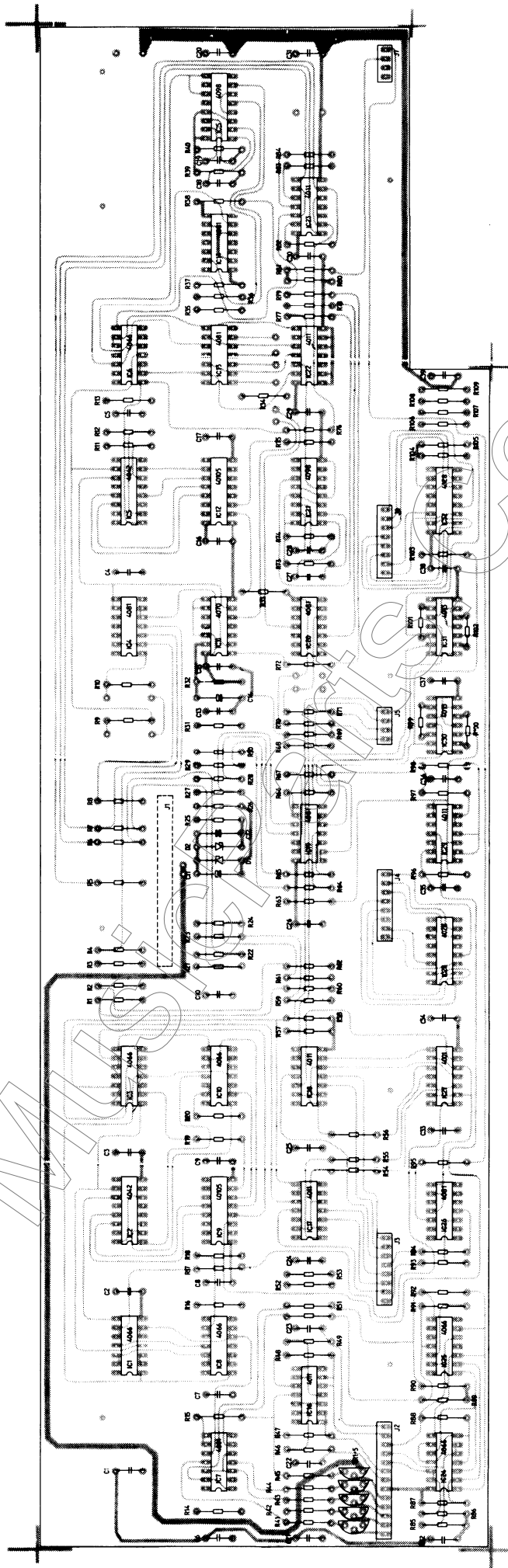

54 3222 MONITOR CONTROL WITH AI TUNING BOARD

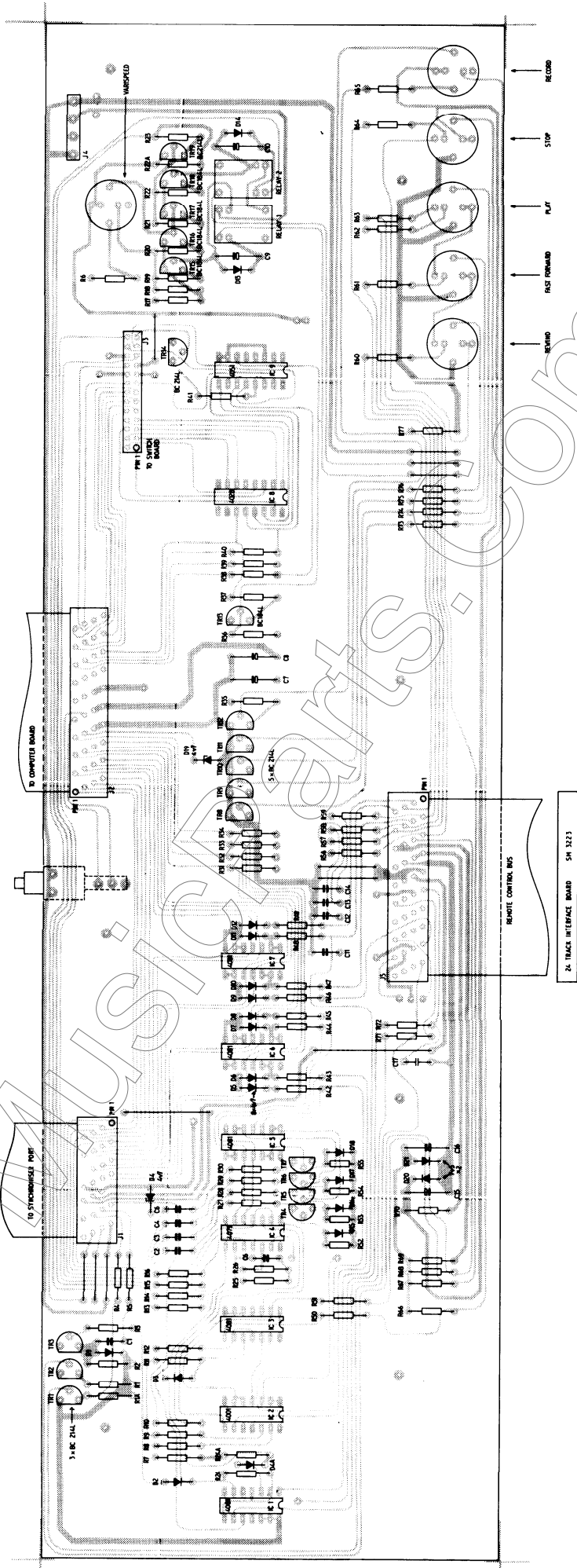

24-TRACK INTERFACE BOARD 54 3123

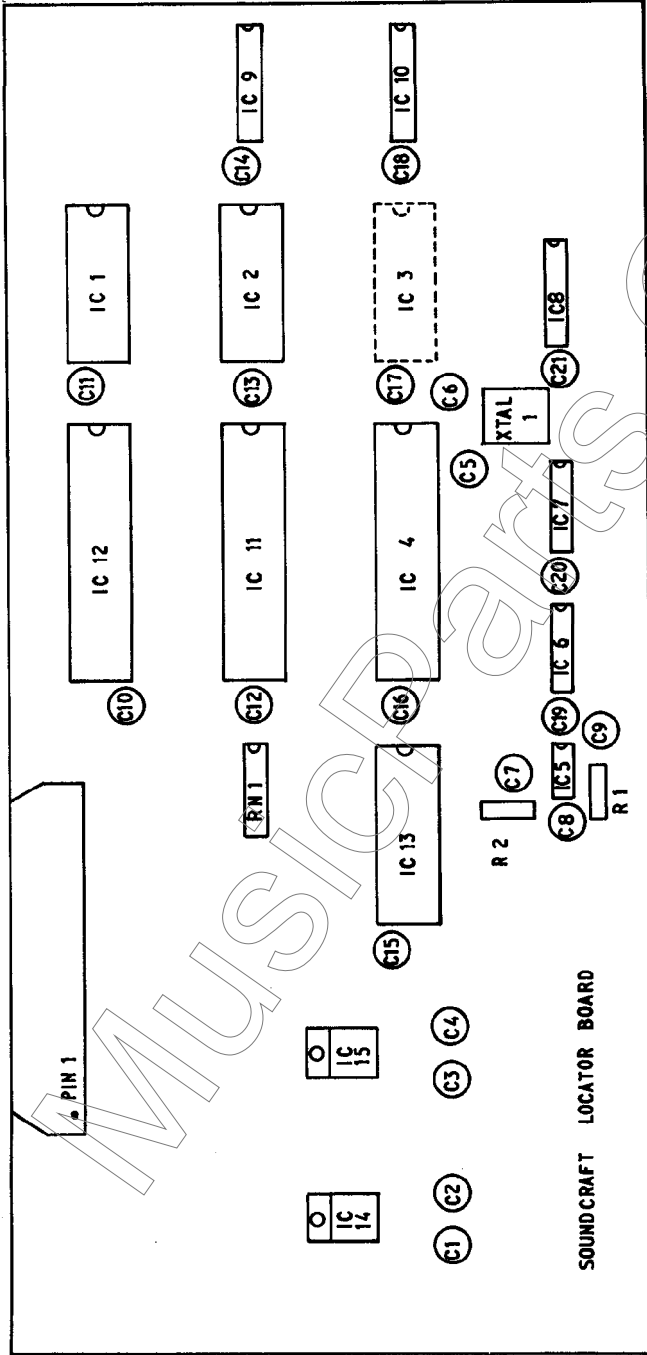

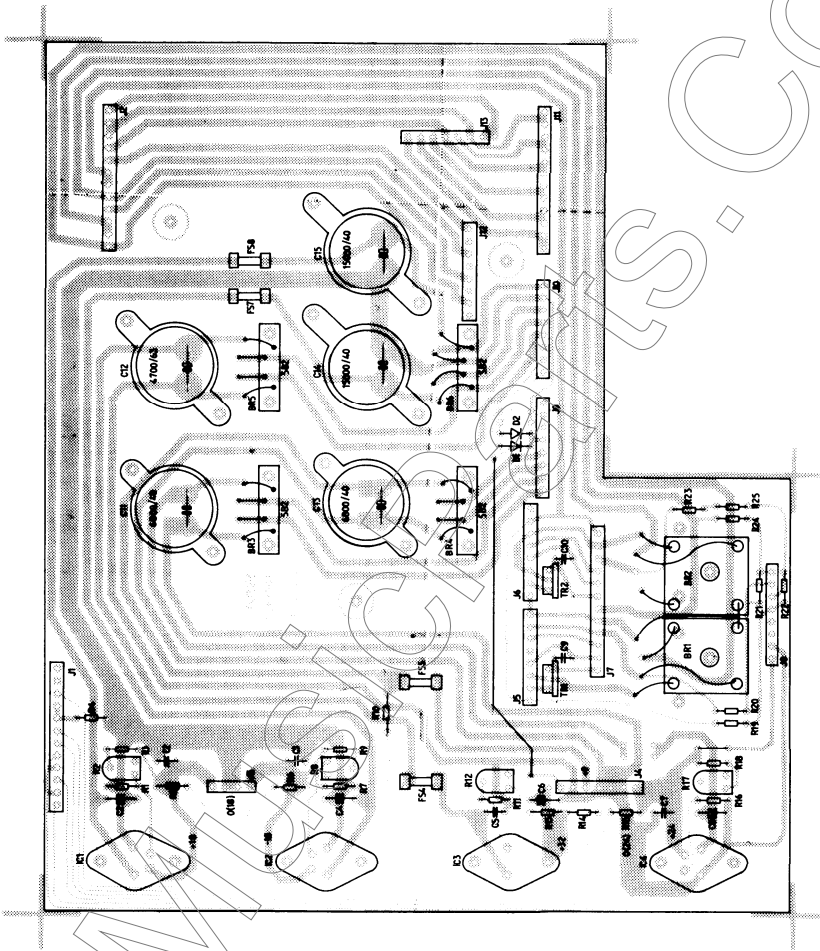

TITLE	PCB BOARD COMPONENT LAYOUT
DWG. No. 54 7008	

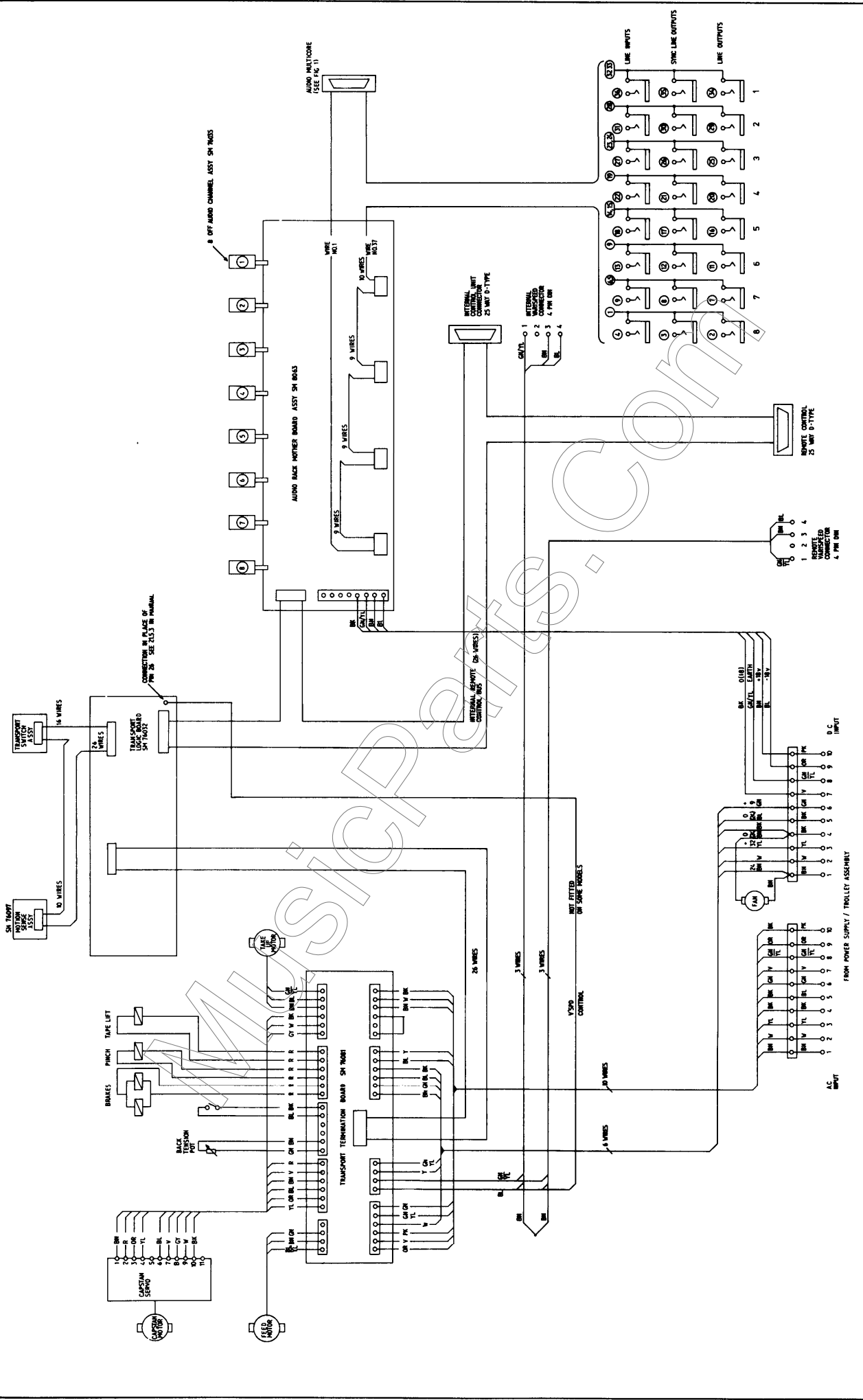

TITLE SCH 300 SH 300 TYPING (LATER TYPE)		DRN HL TRCD CHD T J		MATL FINISH SCALE		HOLE INDEX		TOLERANCE All imperial dimensions ± 0.01 All metric dimensions ± 0.25mm All angles ± 0.50° Unless otherwise stated		NOTES THIRD ANGLE PROJECTION	
SOUNDRAFT MARKETS LTD 5-8 GREAT SUTTON STREET LONDON EC1V 0BK TELEPHONE 01 251 3631/2/3 TELEGRAMS SOUNDRAFT LON EC1 TELELEX UK No 21108 USA No 224408		DRG No SH 3000									

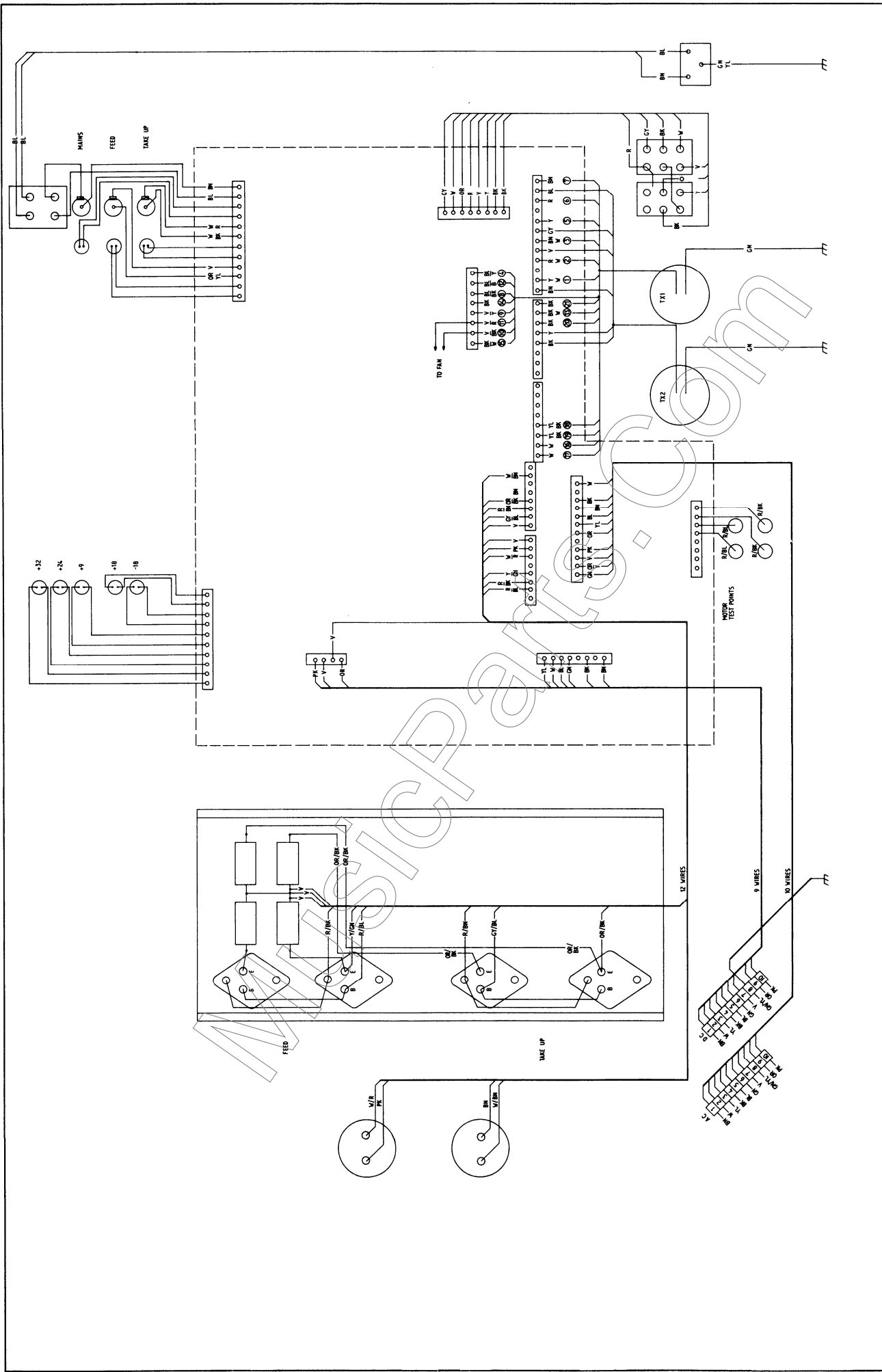

TITLE 72 SERIES LOUD TROLLEY	
SOUNDSCRAFT MAGNETICS LTD 5-8 GREAT SUTTON STREET LONDON EC1V 0BX TELEPHONE: 01-251-3631/2/3 TELEGRAMS: SOUNDSCRAFT LON EC1 TELEX: UK-NO.21158. USA-NO.224408	
DRN	HL
TRCD	
MATL	HOLE INDEX
FINISH	
SCALE	
TOLERANCE	NOTES
All imperial dimensions ± 0.01 All metric dimensions $\pm 0.25\text{mm}$ All angles $\pm 0.50^\circ$ Unless otherwise stated	
THIRD ANGLE PROJECTION	
1818	

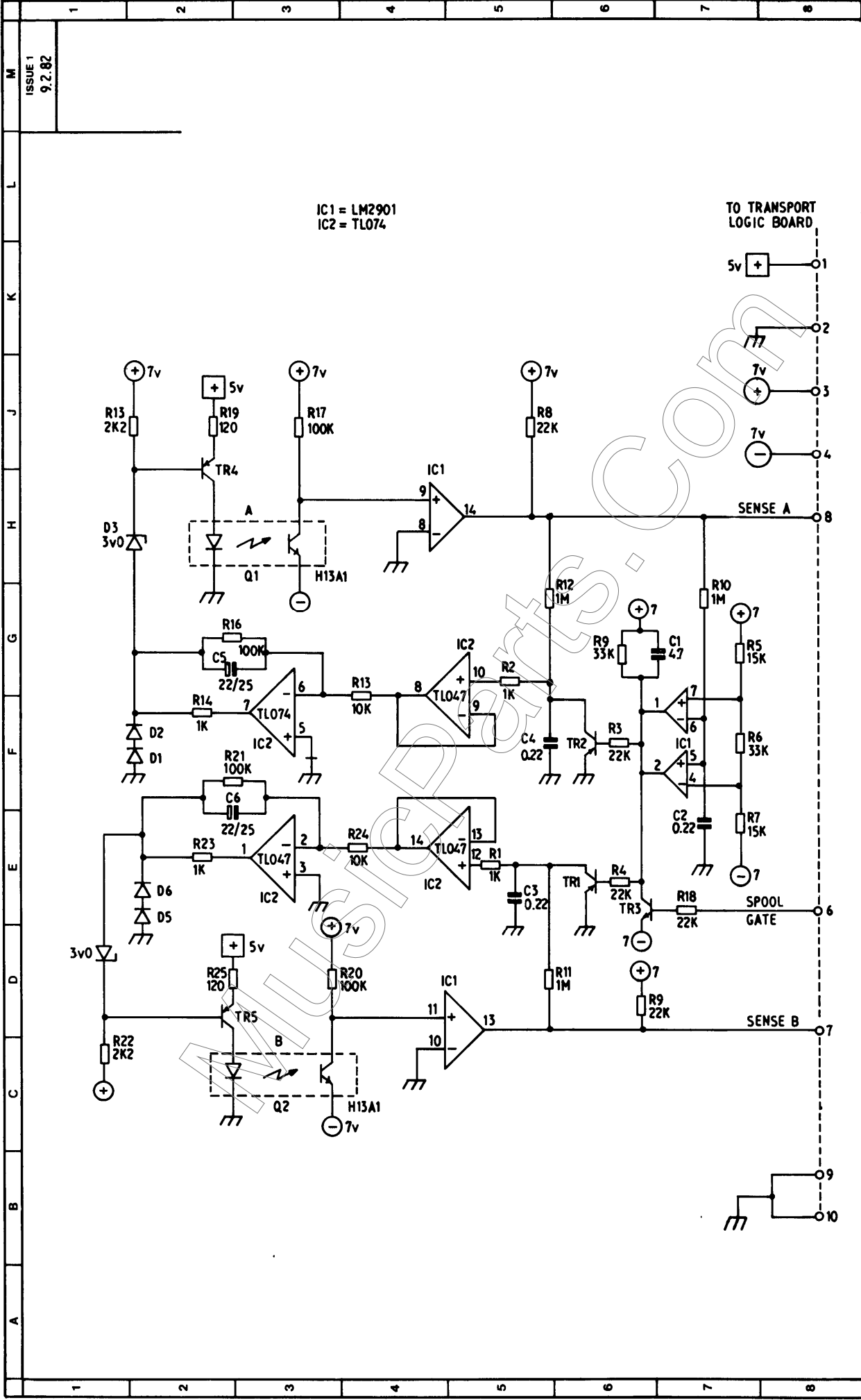

TITLE MOTION SENSE ASSY (SELF COMPENSATING) CIRCUIT DIAGRAM		DRG. No. SM 76097/CD	
SOUNDRAFT MAGNETICS LTD 9-10 GREAT SUTTON STREET LONDON EC1V 0BX. TELEPHONE: 01-251-3831/2/3 TELEGRAMS: SOUNDRAFT LDN EC1 TELEX: LUK. No. 21198. USA. No. 224408		DRN HL	CHKD T.J.
MATL	FINISH	HOLE INDEX	TOLERANCE
SCALE			
THIRD ANGLE PROJECTION			

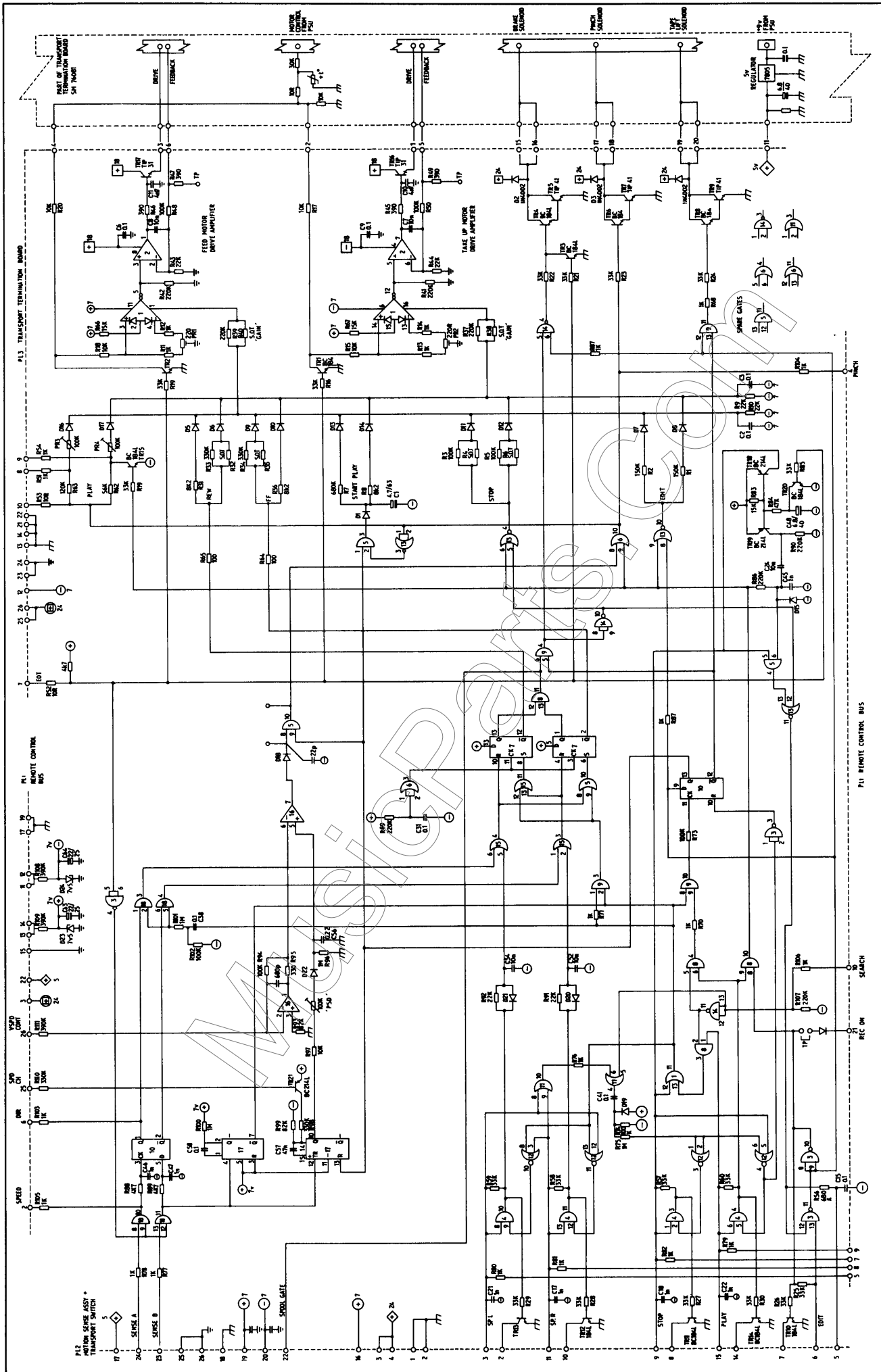

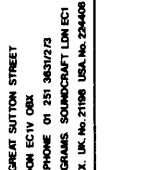
<p>201 82 Issue 1</p>	<p>THIRD ANGLE PROJECTION</p> 	<p>NOTES</p>	<p>HOLE INDEX</p>	<p>MATERIAL</p> <p>FINISH</p> <p>SCALE</p>	<p>DRAWN</p> <p>TRCD</p> <p>CHKD</p>	<p>TITLE</p> <p>TRANSPORT UDC BOARD</p> <p>SCF 762</p>	<p>SOUNDSCRAFT MAGNETICS LTD</p> <p>5-8 GREAT SUTTON STREET</p> <p>LONDON EC1V 0BK</p> <p>TELEPHONE 01 251 3631/2/3</p> <p>TELEGRAMS SOUNDSCRAFT LDM ECI</p> <p>TELEX UK. NO. 21198 USA. NO. 224408</p> <p>DRG. NO. SH 7603/CD</p>
-----------------------	---	--------------	-------------------	--	--------------------------------------	--	--

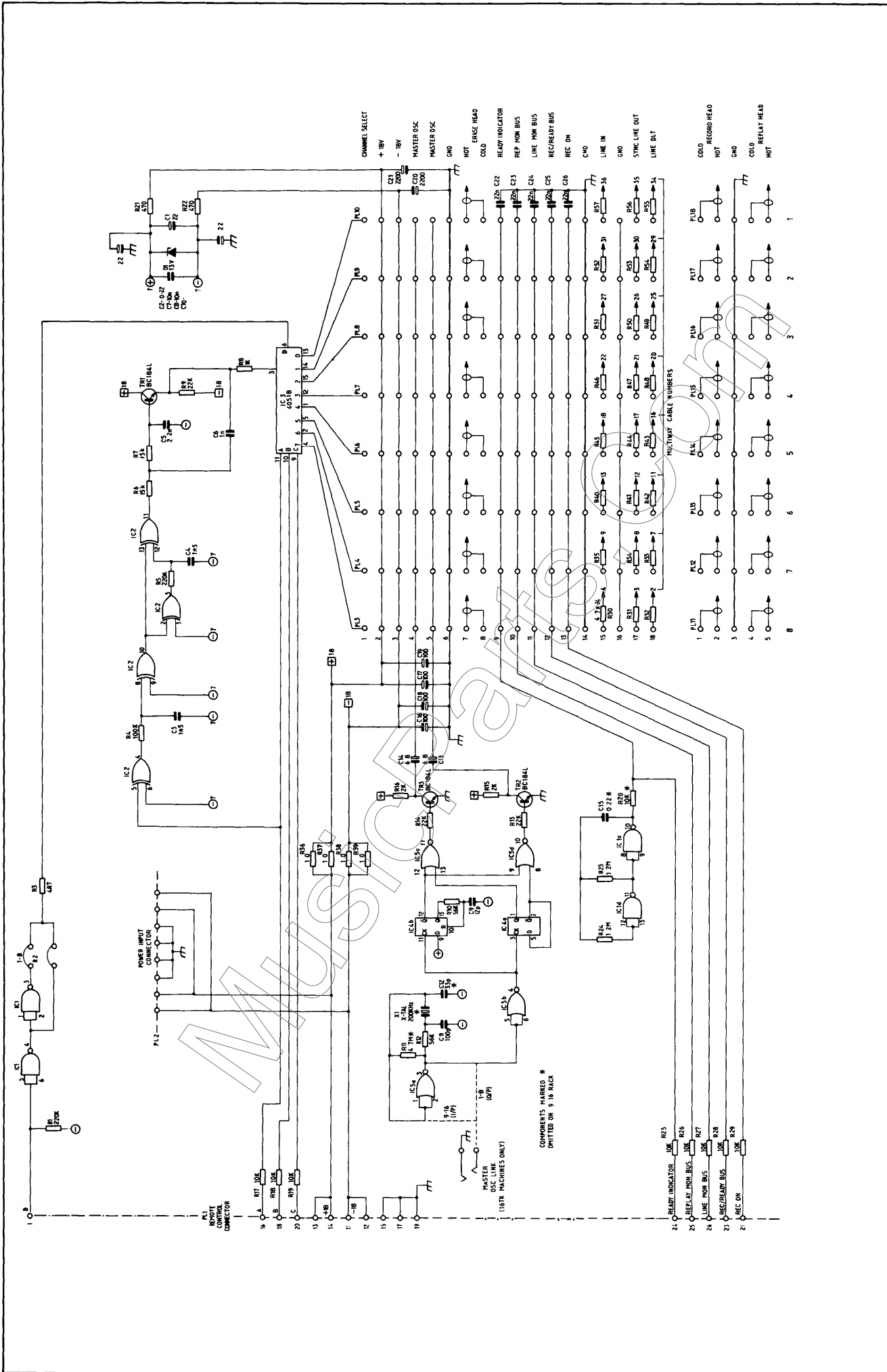

Issue	Issue 2	Issue 3	Issue 5	9 12 80
1	11 - 79	2	5 - 80	
2		3		
3		4		
4		5		
5		6		
6		7		
7		8		
8		9		
9		10		
10		11		
11		12		
12		13		
13		14		
14		15		
15		16		
16		17		
17		18		
18		19		
19		20		
20		21		
21		22		
22		23		
23		24		
24		25		
25		26		
26		27		
27		28		
28		29		
29		30		
30		31		
31		32		
32		33		
33		34		
34		35		
35		36		
36		37		
37		38		
38		39		
39		40		
40		41		
41		42		
42		43		
43		44		
44		45		
45		46		
46		47		
47		48		
48		49		
49		50		
50		51		
51		52		
52		53		
53		54		
54		55		
55		56		
56		57		
57		58		
58		59		
59		60		
60		61		
61		62		
62		63		
63		64		
64		65		
65		66		
66		67		
67		68		
68		69		
69		70		
70		71		
71		72		
72		73		
73		74		
74		75		
75		76		
76		77		
77		78		
78		79		
79		80		
80		81		
81		82		
82		83		
83		84		
84		85		
85		86		
86		87		
87		88		
88		89		
89		90		
90		91		
91		92		
92		93		
93		94		
94		95		
95		96		
96		97		
97		98		
98		99		
99		100		

TITLE: SCR '82 AUDIO RACK CIRCUIT DIAGRAM
 Dwg. No. SM 7603/2D
 SOUNDSCRAFT MAGNETICS LTD
 5-9 GREAT SUTTON STREET
 LONDON EC3V 0BB
 TELEPHONE 01 251 9631/2/3
 TELEGRAMS SOUNDSCRAFT LON EC1
 TELEFAX UK No 21198 USA No 224-608
 DRN: Bury, TRCD, CHMD, T. J.
 HOLE INDEX: All imperial dimensions ± 0.01, All metric dimensions ± 0.25mm, All angles ± 0.50° Unless otherwise stated.
 TOLERANCE: RESISTORS IN OHMS, CAPACITORS IN MICRO FARADS UNLESS OTHERWISE STATED.
 THUMB ANGLE PROJECTION: (Symbol)
 NOTES: (Symbol)

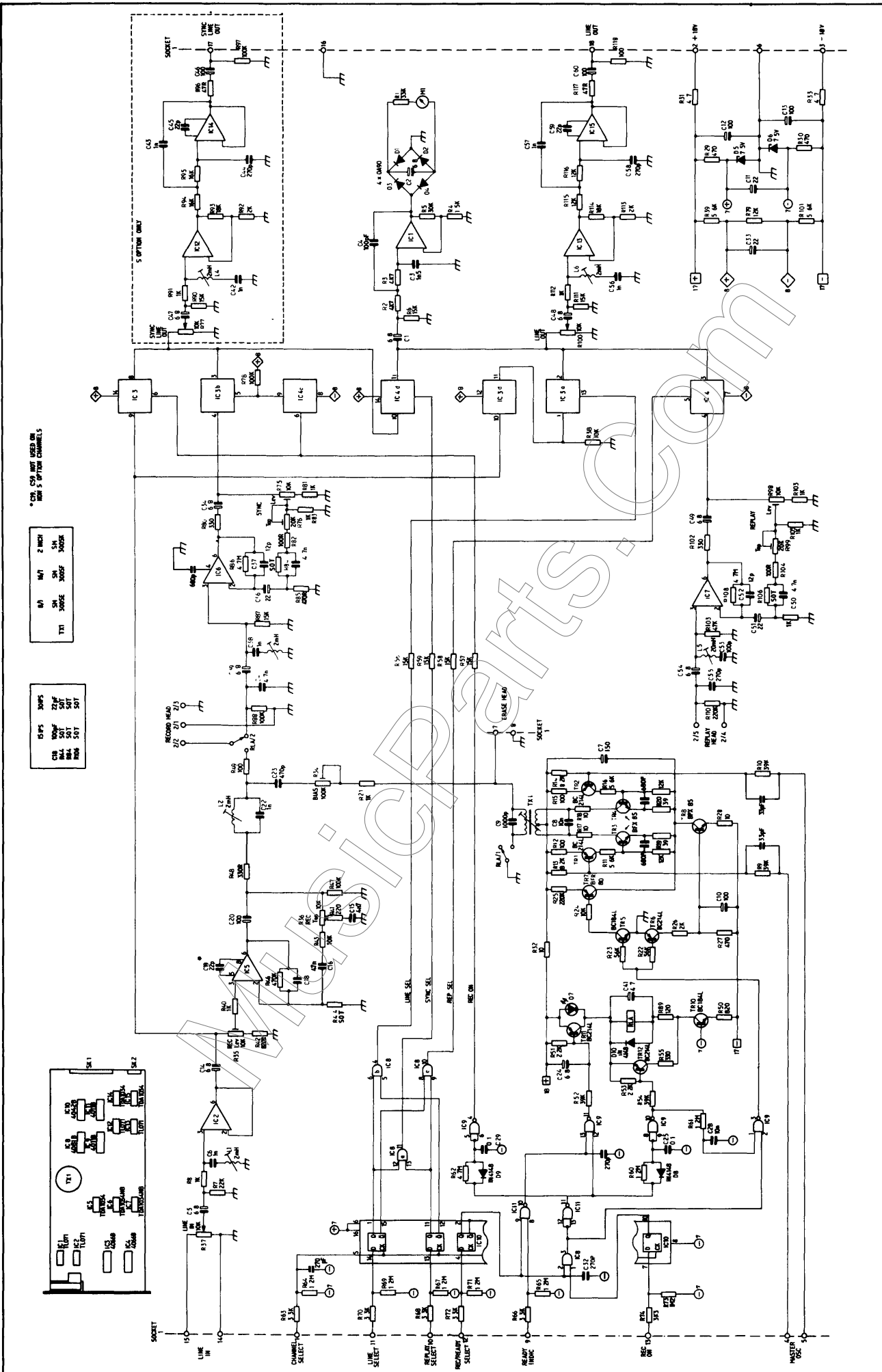

* C1, C5, C9 NOT USED ON
5 OPTION CHANNELS

W1	W4	2 INCH
W2	W5	5 IN
W3	W6	3000F 3000V

C18	500PF	25V
C19	100PF	50V
C20	100PF	50V
C21	100PF	50V
C22	100PF	50V

TOLERANCE		HOLE INDEX		TITLE	
All imperial dimensions ± 0.01		All metric dimensions ± 0.25mm		SOUNDSCRAFT MAGNETICS LTD	
All angles ± 0.50°		Unless otherwise stated		5-8 GREAT BUTTON STREET	
				LONDON EC1V 0BX	
				TELEPHONE 01 251 3631/2/3	
				TELEGRAMS SOUNDSCRAFT LHM EC1	
				TELEX UK. No. 21188 USA No. 224408	
				DRAWING No. 51 7015/CD	
				ALSO CHANNEL HE III	
				1/2 INCHES	
				FINISH	
				SCALE	
				CHKD T J	
				DWG No. 51 7015/CD	

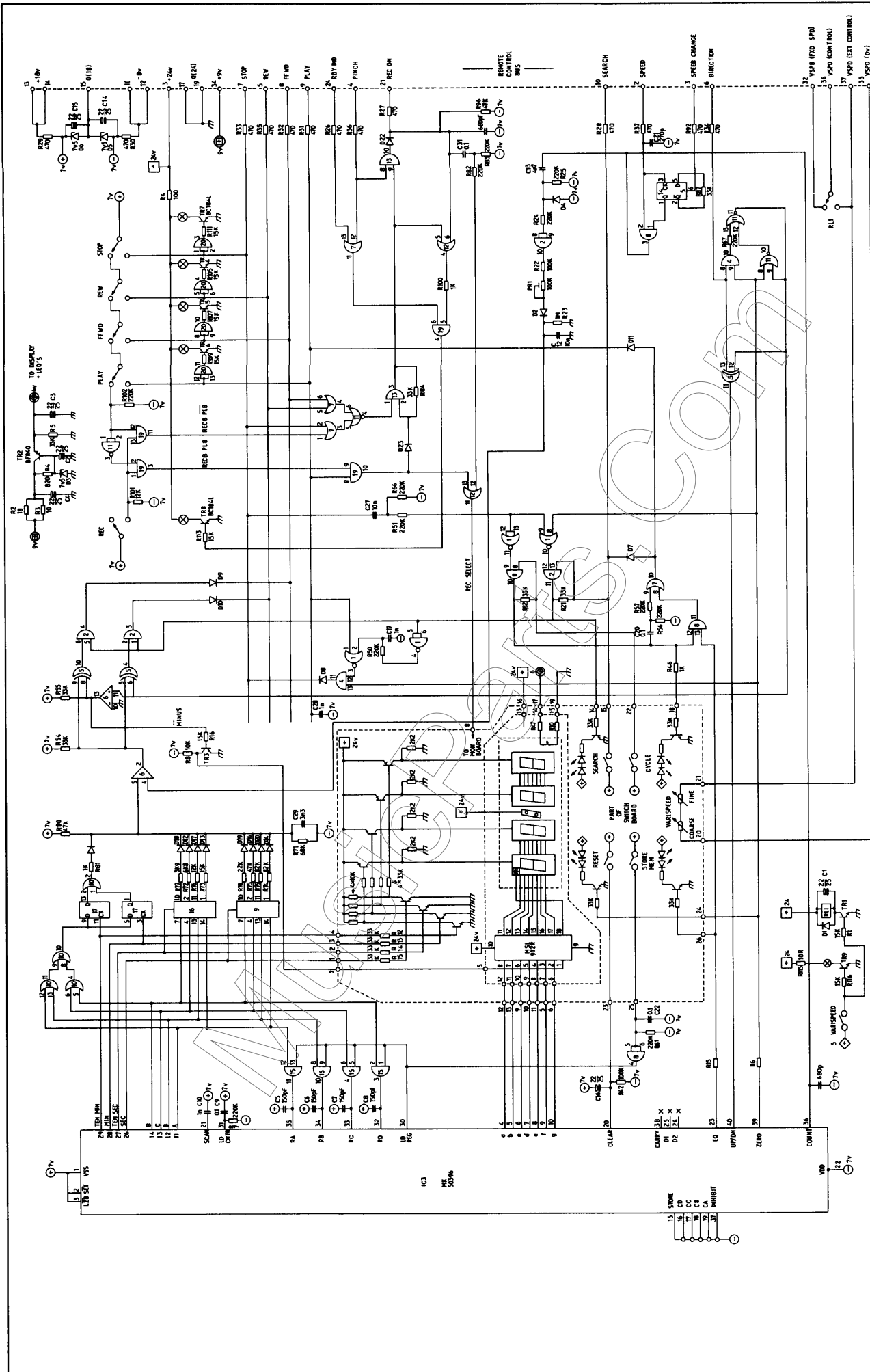

TITLE		DRAWN		MATERIAL		TOLERANCE		NOTES	
LOW COST REMOTE CONTROL TRANSPORT SECTION CIRCUIT DIAGRAM		HL	TRCD	FINISH	SCALE	All imperial dimensions ± 0.01 All metric dimensions ± 0.25mm All angles ± 0.50° Unless otherwise stated		THIRD ANGLE PROJECTION 	
SOUNDGRAFT ELECTRONICS LTD 5-8 GREAT BUTTON STREET LONDON EC1V 0BL TELEPHONE 01 251 3631/2/3 TELEGRAMS SOUNDGRAFT LOW EC1 TELEX UK. NO. 21188 USA. NO. 224408		1	1						
ORG. No. 5H 7608/03									

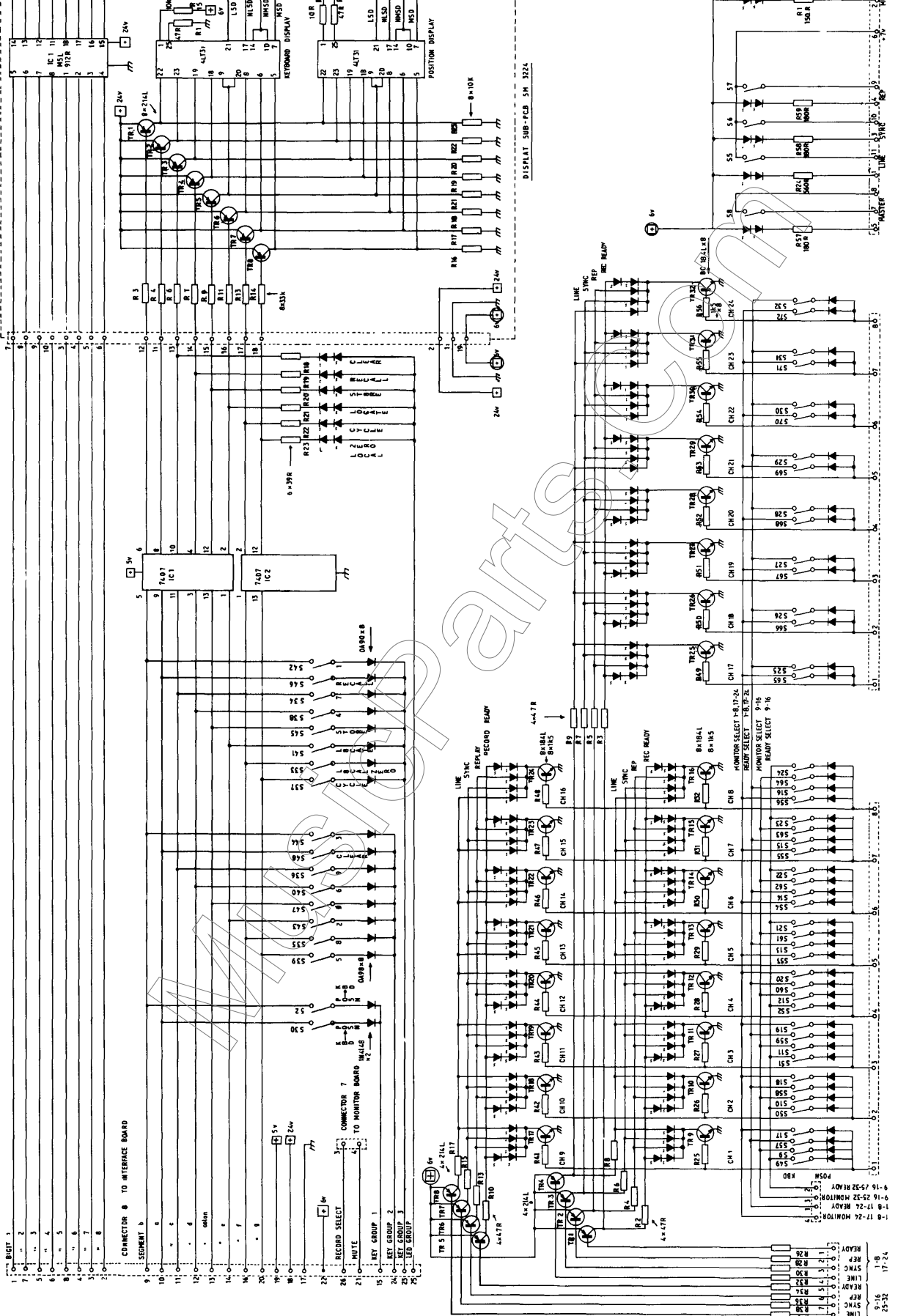

- 1 BIT 1
- 2 BIT 2
- 3 BIT 3
- 4 BIT 4
- 5 BIT 5
- 6 BIT 6
- 7 BIT 7
- 8 BIT 8
- 9 BIT 9
- 10 BIT 10
- 11 BIT 11
- 12 BIT 12
- 13 BIT 13
- 14 BIT 14
- 15 BIT 15
- 16 BIT 16
- 17 BIT 17
- 18 BIT 18
- 19 BIT 19
- 20 BIT 20
- 21 BIT 21
- 22 BIT 22
- 23 BIT 23
- 24 BIT 24
- 25 BIT 25
- 26 BIT 26
- 27 BIT 27
- 28 BIT 28
- 29 BIT 29
- 30 BIT 30
- 31 BIT 31
- 32 BIT 32
- 33 BIT 33
- 34 BIT 34
- 35 BIT 35
- 36 BIT 36
- 37 BIT 37
- 38 BIT 38
- 39 BIT 39
- 40 BIT 40
- 41 BIT 41
- 42 BIT 42
- 43 BIT 43
- 44 BIT 44
- 45 BIT 45
- 46 BIT 46
- 47 BIT 47
- 48 BIT 48
- 49 BIT 49
- 50 BIT 50
- 51 BIT 51
- 52 BIT 52
- 53 BIT 53
- 54 BIT 54
- 55 BIT 55
- 56 BIT 56
- 57 BIT 57
- 58 BIT 58
- 59 BIT 59
- 60 BIT 60
- 61 BIT 61
- 62 BIT 62
- 63 BIT 63
- 64 BIT 64
- 65 BIT 65
- 66 BIT 66
- 67 BIT 67
- 68 BIT 68
- 69 BIT 69
- 70 BIT 70
- 71 BIT 71
- 72 BIT 72
- 73 BIT 73
- 74 BIT 74
- 75 BIT 75
- 76 BIT 76
- 77 BIT 77
- 78 BIT 78
- 79 BIT 79
- 80 BIT 80
- 81 BIT 81
- 82 BIT 82
- 83 BIT 83
- 84 BIT 84
- 85 BIT 85
- 86 BIT 86
- 87 BIT 87
- 88 BIT 88
- 89 BIT 89
- 90 BIT 90
- 91 BIT 91
- 92 BIT 92
- 93 BIT 93
- 94 BIT 94
- 95 BIT 95
- 96 BIT 96
- 97 BIT 97
- 98 BIT 98
- 99 BIT 99
- 100 BIT 100

DRN	SR	TITL
TRCD		SOUNDRAFT MAGNETICS LTD
CHND	TJ	5 B GREAT SUTTON STREET
		LONDON EC IV 6DP
		TELEPHONE 01 251 36312/3
		TELEGRAMS SOUNDRAFT LDN EC1
		TELEX UK No.21989 USA No.01 2203
		DRG No 5M 3221

11-11-80
15.1
17-24

CONNECTOR 3
CONNECTOR 4
CONNECTOR 5
CONNECTOR 6
CONNECTOR 7
CONNECTOR 8

17-24
15.1
11-11-80

9-16-52-32 READY
9-16-52-32 MONITOR
9-16-52-32 MONITOR
9-16-52-32 MONITOR

9-16-52-32 MONITOR
9-16-52-32 MONITOR
9-16-52-32 MONITOR
9-16-52-32 MONITOR

9-16-52-32 MONITOR
9-16-52-32 MONITOR
9-16-52-32 MONITOR
9-16-52-32 MONITOR

9-16-52-32 MONITOR
9-16-52-32 MONITOR
9-16-52-32 MONITOR
9-16-52-32 MONITOR

9-16-52-32 MONITOR
9-16-52-32 MONITOR
9-16-52-32 MONITOR
9-16-52-32 MONITOR

9-16-52-32 MONITOR
9-16-52-32 MONITOR
9-16-52-32 MONITOR
9-16-52-32 MONITOR

9-16-52-32 MONITOR
9-16-52-32 MONITOR
9-16-52-32 MONITOR
9-16-52-32 MONITOR

9-16-52-32 MONITOR
9-16-52-32 MONITOR
9-16-52-32 MONITOR
9-16-52-32 MONITOR

9-16-52-32 MONITOR
9-16-52-32 MONITOR
9-16-52-32 MONITOR
9-16-52-32 MONITOR

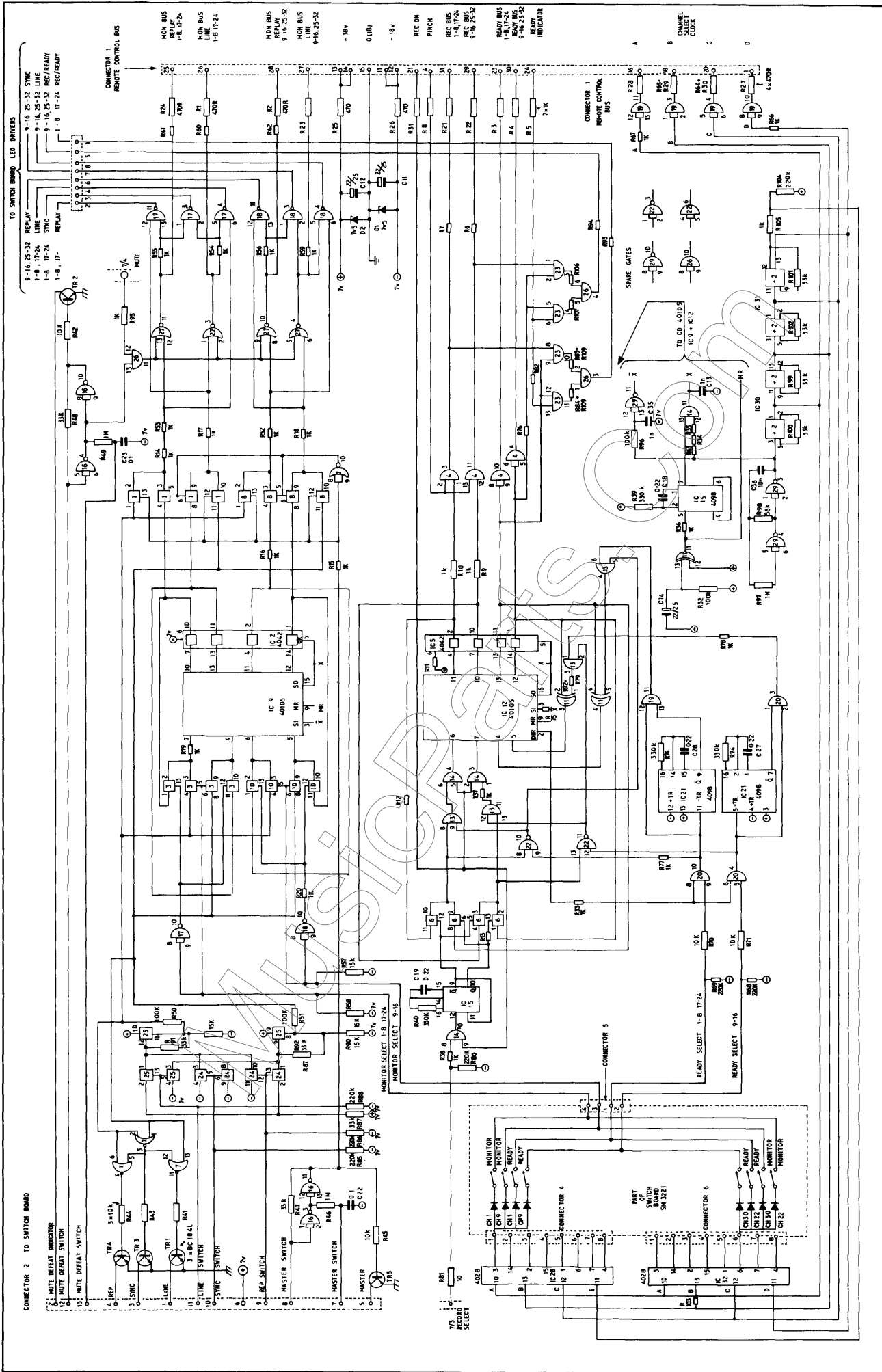

18	11	90	3	10	90	Issue 1
15	11	90	2	15	90	15
<p>NOTES</p> <p>TOLERANCE</p> <p>All imperial dimensions ±0.01 All metric dimensions ±0.25mm All angles ±0.50° Unless otherwise stated</p> <p>HOLE INDEX</p> <p>MATL</p> <p>FINISH</p> <p>SCALE</p>						
<p>TRCD</p> <p>CHWD</p>						
<p>SOUNDSCRAFT MAGNETICS LTD</p> <p>5-8 GREAT SUTTON STREET</p> <p>LONDON EC1</p> <p>TELEPHONE 01 251 3831/2/3</p> <p>TELEGRAMS: SOUNDSCRAFT LON ECT1</p> <p>TELEX: UK No 21198 USA No 01-2203</p>						
<p>TITLE</p> <p>TWENTYFOUR TRACK</p> <p>MONITOR BOARD</p>						
<p>DIRC No 5M 3222 CD</p>						

HEADER (TD INTERFACE BOARD)

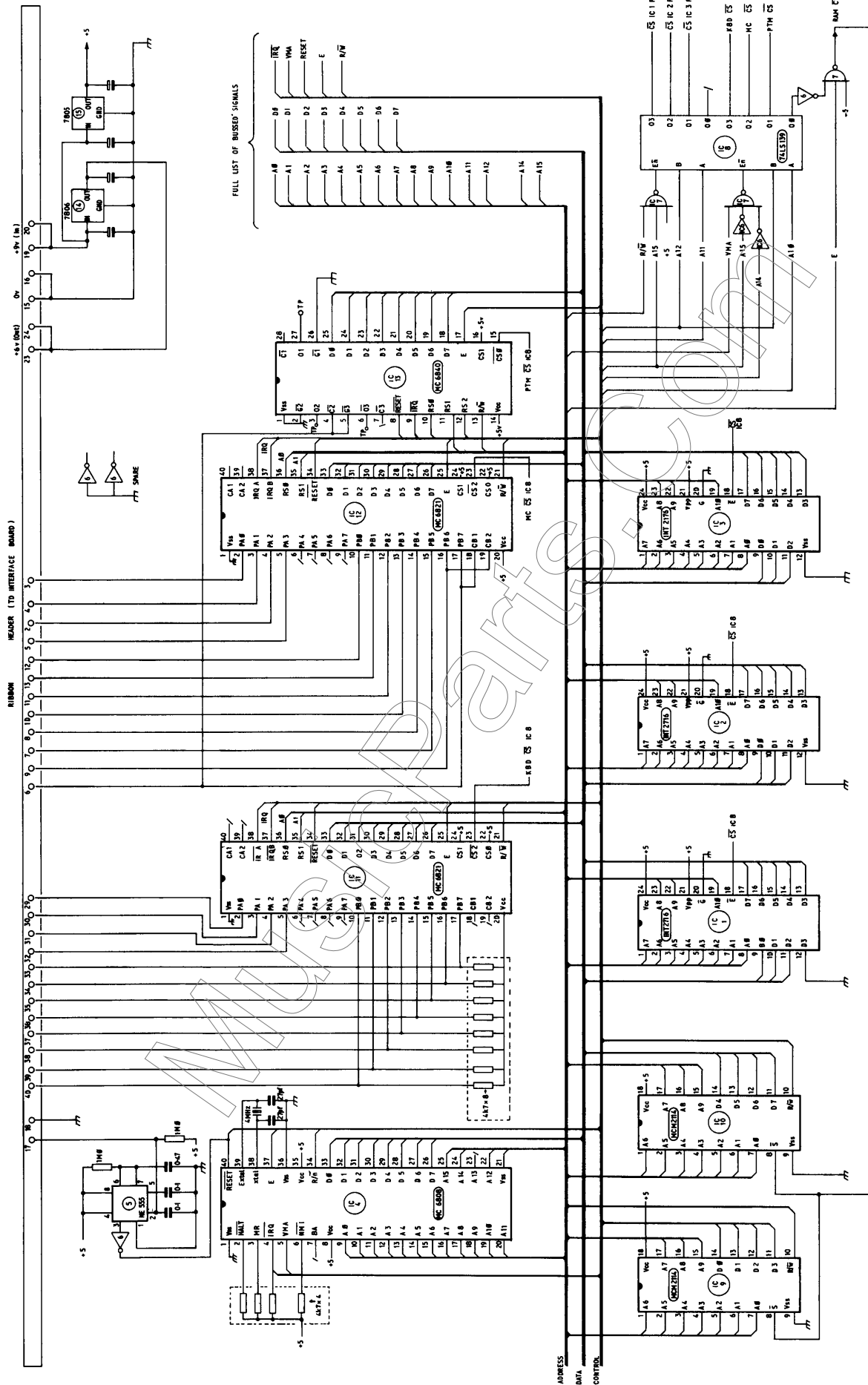

FULL LIST OF BUSSED SIGNALS

- IRG
- VMA
- RESET
- E
- R/W
- A0-A15
- D0-D7
- CS0-CS7
- CS8-CS15
- CS16-CS23
- CS24-CS31
- CS32-CS39
- CS40-CS47
- CS48-CS55
- CS56-CS63
- CS64-CS71
- CS72-CS79
- CS80-CS87
- CS88-CS95
- CS96-CS103
- CS104-CS111
- CS112-CS119
- CS120-CS127
- CS128-CS135
- CS136-CS143
- CS144-CS151
- CS152-CS159
- CS160-CS167
- CS168-CS175
- CS176-CS183
- CS184-CS191
- CS192-CS199
- CS200-CS207
- CS208-CS215
- CS216-CS223
- CS224-CS231
- CS232-CS239
- CS240-CS247
- CS248-CS255
- CS256-CS263
- CS264-CS271
- CS272-CS279
- CS280-CS287
- CS288-CS295
- CS296-CS303
- CS304-CS311
- CS312-CS319
- CS320-CS327
- CS328-CS335
- CS336-CS343
- CS344-CS351
- CS352-CS359
- CS360-CS367
- CS368-CS375
- CS376-CS383
- CS384-CS391
- CS392-CS399
- CS400-CS407
- CS408-CS415
- CS416-CS423
- CS424-CS431
- CS432-CS439
- CS440-CS447
- CS448-CS455
- CS456-CS463
- CS464-CS471
- CS472-CS479
- CS480-CS487
- CS488-CS495
- CS496-CS503
- CS504-CS511
- CS512-CS519
- CS520-CS527
- CS528-CS535
- CS536-CS543
- CS544-CS551
- CS552-CS559
- CS560-CS567
- CS568-CS575
- CS576-CS583
- CS584-CS591
- CS592-CS599
- CS600-CS607
- CS608-CS615
- CS616-CS623
- CS624-CS631
- CS632-CS639
- CS640-CS647
- CS648-CS655
- CS656-CS663
- CS664-CS671
- CS672-CS679
- CS680-CS687
- CS688-CS695
- CS696-CS703
- CS704-CS711
- CS712-CS719
- CS720-CS727
- CS728-CS735
- CS736-CS743
- CS744-CS751
- CS752-CS759
- CS760-CS767
- CS768-CS775
- CS776-CS783
- CS784-CS791
- CS792-CS799
- CS800-CS807
- CS808-CS815
- CS816-CS823
- CS824-CS831
- CS832-CS839
- CS840-CS847
- CS848-CS855
- CS856-CS863
- CS864-CS871
- CS872-CS879
- CS880-CS887
- CS888-CS895
- CS896-CS903
- CS904-CS911
- CS912-CS919
- CS920-CS927
- CS928-CS935
- CS936-CS943
- CS944-CS951
- CS952-CS959
- CS960-CS967
- CS968-CS975
- CS976-CS983
- CS984-CS991
- CS992-CS999
- CS1000-CS1007
- CS1008-CS1015
- CS1016-CS1023
- CS1024-CS1031
- CS1032-CS1039
- CS1040-CS1047
- CS1048-CS1055
- CS1056-CS1063
- CS1064-CS1071
- CS1072-CS1079
- CS1080-CS1087
- CS1088-CS1095
- CS1096-CS1103
- CS1104-CS1111
- CS1112-CS1119
- CS1120-CS1127
- CS1128-CS1135
- CS1136-CS1143
- CS1144-CS1151
- CS1152-CS1159
- CS1160-CS1167
- CS1168-CS1175
- CS1176-CS1183
- CS1184-CS1191
- CS1192-CS1199
- CS1200-CS1207
- CS1208-CS1215
- CS1216-CS1223
- CS1224-CS1231
- CS1232-CS1239
- CS1240-CS1247
- CS1248-CS1255
- CS1256-CS1263
- CS1264-CS1271
- CS1272-CS1279
- CS1280-CS1287
- CS1288-CS1295
- CS1296-CS1303
- CS1304-CS1311
- CS1312-CS1319
- CS1320-CS1327
- CS1328-CS1335
- CS1336-CS1343
- CS1344-CS1351
- CS1352-CS1359
- CS1360-CS1367
- CS1368-CS1375
- CS1376-CS1383
- CS1384-CS1391
- CS1392-CS1399
- CS1400-CS1407
- CS1408-CS1415
- CS1416-CS1423
- CS1424-CS1431
- CS1432-CS1439
- CS1440-CS1447
- CS1448-CS1455
- CS1456-CS1463
- CS1464-CS1471
- CS1472-CS1479
- CS1480-CS1487
- CS1488-CS1495
- CS1496-CS1503
- CS1504-CS1511
- CS1512-CS1519
- CS1520-CS1527
- CS1528-CS1535
- CS1536-CS1543
- CS1544-CS1551
- CS1552-CS1559
- CS1560-CS1567
- CS1568-CS1575
- CS1576-CS1583
- CS1584-CS1591
- CS1592-CS1599
- CS1600-CS1607
- CS1608-CS1615
- CS1616-CS1623
- CS1624-CS1631
- CS1632-CS1639
- CS1640-CS1647
- CS1648-CS1655
- CS1656-CS1663
- CS1664-CS1671
- CS1672-CS1679
- CS1680-CS1687
- CS1688-CS1695
- CS1696-CS1703
- CS1704-CS1711
- CS1712-CS1719
- CS1720-CS1727
- CS1728-CS1735
- CS1736-CS1743
- CS1744-CS1751
- CS1752-CS1759
- CS1760-CS1767
- CS1768-CS1775
- CS1776-CS1783
- CS1784-CS1791
- CS1792-CS1799
- CS1800-CS1807
- CS1808-CS1815
- CS1816-CS1823
- CS1824-CS1831
- CS1832-CS1839
- CS1840-CS1847
- CS1848-CS1855
- CS1856-CS1863
- CS1864-CS1871
- CS1872-CS1879
- CS1880-CS1887
- CS1888-CS1895
- CS1896-CS1903
- CS1904-CS1911
- CS1912-CS1919
- CS1920-CS1927
- CS1928-CS1935
- CS1936-CS1943
- CS1944-CS1951
- CS1952-CS1959
- CS1960-CS1967
- CS1968-CS1975
- CS1976-CS1983
- CS1984-CS1991
- CS1992-CS1999
- CS2000-CS2007
- CS2008-CS2015
- CS2016-CS2023
- CS2024-CS2031
- CS2032-CS2039
- CS2040-CS2047
- CS2048-CS2055
- CS2056-CS2063
- CS2064-CS2071
- CS2072-CS2079
- CS2080-CS2087
- CS2088-CS2095
- CS2096-CS2103
- CS2104-CS2111
- CS2112-CS2119
- CS2120-CS2127
- CS2128-CS2135
- CS2136-CS2143
- CS2144-CS2151
- CS2152-CS2159
- CS2160-CS2167
- CS2168-CS2175
- CS2176-CS2183
- CS2184-CS2191
- CS2192-CS2199
- CS2200-CS2207
- CS2208-CS2215
- CS2216-CS2223
- CS2224-CS2231
- CS2232-CS2239
- CS2240-CS2247
- CS2248-CS2255
- CS2256-CS2263
- CS2264-CS2271
- CS2272-CS2279
- CS2280-CS2287
- CS2288-CS2295
- CS2296-CS2303
- CS2304-CS2311
- CS2312-CS2319
- CS2320-CS2327
- CS2328-CS2335
- CS2336-CS2343
- CS2344-CS2351
- CS2352-CS2359
- CS2360-CS2367
- CS2368-CS2375
- CS2376-CS2383
- CS2384-CS2391
- CS2392-CS2399
- CS2400-CS2407
- CS2408-CS2415
- CS2416-CS2423
- CS2424-CS2431
- CS2432-CS2439
- CS2440-CS2447
- CS2448-CS2455
- CS2456-CS2463
- CS2464-CS2471
- CS2472-CS2479
- CS2480-CS2487
- CS2488-CS2495
- CS2496-CS2503
- CS2504-CS2511
- CS2512-CS2519
- CS2520-CS2527
- CS2528-CS2535
- CS2536-CS2543
- CS2544-CS2551
- CS2552-CS2559
- CS2560-CS2567
- CS2568-CS2575
- CS2576-CS2583
- CS2584-CS2591
- CS2592-CS2599
- CS2600-CS2607
- CS2608-CS2615
- CS2616-CS2623
- CS2624-CS2631
- CS2632-CS2639
- CS2640-CS2647
- CS2648-CS2655
- CS2656-CS2663
- CS2664-CS2671
- CS2672-CS2679
- CS2680-CS2687
- CS2688-CS2695
- CS2696-CS2703
- CS2704-CS2711
- CS2712-CS2719
- CS2720-CS2727
- CS2728-CS2735
- CS2736-CS2743
- CS2744-CS2751
- CS2752-CS2759
- CS2760-CS2767
- CS2768-CS2775
- CS2776-CS2783
- CS2784-CS2791
- CS2792-CS2799
- CS2800-CS2807
- CS2808-CS2815
- CS2816-CS2823
- CS2824-CS2831
- CS2832-CS2839
- CS2840-CS2847
- CS2848-CS2855
- CS2856-CS2863
- CS2864-CS2871
- CS2872-CS2879
- CS2880-CS2887
- CS2888-CS2895
- CS2896-CS2903
- CS2904-CS2911
- CS2912-CS2919
- CS2920-CS2927
- CS2928-CS2935
- CS2936-CS2943
- CS2944-CS2951
- CS2952-CS2959
- CS2960-CS2967
- CS2968-CS2975
- CS2976-CS2983
- CS2984-CS2991
- CS2992-CS2999
- CS3000-CS3007
- CS3008-CS3015
- CS3016-CS3023
- CS3024-CS3031
- CS3032-CS3039
- CS3040-CS3047
- CS3048-CS3055
- CS3056-CS3063
- CS3064-CS3071
- CS3072-CS3079
- CS3080-CS3087
- CS3088-CS3095
- CS3096-CS3103
- CS3104-CS3111
- CS3112-CS3119
- CS3120-CS3127
- CS3128-CS3135
- CS3136-CS3143
- CS3144-CS3151
- CS3152-CS3159
- CS3160-CS3167
- CS3168-CS3175
- CS3176-CS3183
- CS3184-CS3191
- CS3192-CS3199
- CS3200-CS3207
- CS3208-CS3215
- CS3216-CS3223
- CS3224-CS3231
- CS3232-CS3239
- CS3240-CS3247
- CS3248-CS3255
- CS3256-CS3263
- CS3264-CS3271
- CS3272-CS3279
- CS3280-CS3287
- CS3288-CS3295
- CS3296-CS3303
- CS3304-CS3311
- CS3312-CS3319
- CS3320-CS3327
- CS3328-CS3335
- CS3336-CS3343
- CS3344-CS3351
- CS3352-CS3359
- CS3360-CS3367
- CS3368-CS3375
- CS3376-CS3383
- CS3384-CS3391
- CS3392-CS3399
- CS3400-CS3407
- CS3408-CS3415
- CS3416-CS3423
- CS3424-CS3431
- CS3432-CS3439
- CS3440-CS3447
- CS3448-CS3455
- CS3456-CS3463
- CS3464-CS3471
- CS3472-CS3479
- CS3480-CS3487
- CS3488-CS3495
- CS3496-CS3503
- CS3504-CS3511
- CS3512-CS3519
- CS3520-CS3527
- CS3528-CS3535
- CS3536-CS3543
- CS3544-CS3551
- CS3552-CS3559
- CS3560-CS3567
- CS3568-CS3575
- CS3576-CS3583
- CS3584-CS3591
- CS3592-CS3599
- CS3600-CS3607
- CS3608-CS3615
- CS3616-CS3623
- CS3624-CS3631
- CS3632-CS3639
- CS3640-CS3647
- CS3648-CS3655
- CS3656-CS3663
- CS3664-CS3671
- CS3672-CS3679
- CS3680-CS3687
- CS3688-CS3695
- CS3696-CS3703
- CS3704-CS3711
- CS3712-CS3719
- CS3720-CS3727
- CS3728-CS3735
- CS3736-CS3743
- CS3744-CS3751
- CS3752-CS3759
- CS3760-CS3767
- CS3768-CS3775
- CS3776-CS3783
- CS3784-CS3791
- CS3792-CS3799
- CS3800-CS3807
- CS3808-CS3815
- CS3816-CS3823
- CS3824-CS3831
- CS3832-CS3839
- CS3840-CS3847
- CS3848-CS3855
- CS3856-CS3863
- CS3864-CS3871
- CS3872-CS3879
- CS3880-CS3887
- CS3888-CS3895
- CS3896-CS3903
- CS3904-CS3911
- CS3912-CS3919
- CS3920-CS3927
- CS3928-CS3935
- CS3936-CS3943
- CS3944-CS3951
- CS3952-CS3959
- CS3960-CS3967
- CS3968-CS3975
- CS3976-CS3983
- CS3984-CS3991
- CS3992-CS3999
- CS4000-CS4007
- CS4008-CS4015
- CS4016-CS4023
- CS4024-CS4031
- CS4032-CS4039
- CS4040-CS4047
- CS4048-CS4055
- CS4056-CS4063
- CS4064-CS4071
- CS4072-CS4079
- CS4080-CS4087
- CS4088-CS4095
- CS4096-CS4103
- CS4104-CS4111
- CS4112-CS4119
- CS4120-CS4127
- CS4128-CS4135
- CS4136-CS4143
- CS4144-CS4151
- CS4152-CS4159
- CS4160-CS4167
- CS4168-CS4175
- CS4176-CS4183
- CS4184-CS4191
- CS4192-CS4199
- CS4200-CS4207
- CS4208-CS4215
- CS4216-CS4223
- CS4224-CS4231
- CS4232-CS4239
- CS4240-CS4247
- CS4248-CS4255
- CS4256-CS4263
- CS4264-CS4271
- CS4272-CS4279
- CS4280-CS4287
- CS4288-CS4295
- CS4296-CS4303
- CS4304-CS4311
- CS4312-CS4319
- CS4320-CS4327
- CS4328-CS4335
- CS4336-CS4343
- CS4344-CS4351
- CS4352-CS4359
- CS4360-CS4367
- CS4368-CS4375
- CS4376-CS4383
- CS4384-CS4391
- CS4392-CS4399
- CS4400-CS4407
- CS4408-CS4415
- CS4416-CS4423
- CS4424-CS4431
- CS4432-CS4439
- CS4440-CS4447
- CS4448-CS4455
- CS4456-CS4463
- CS4464-CS4471
- CS4472-CS4479
- CS4480-CS4487
- CS4488-CS4495
- CS4496-CS4503
- CS4504-CS4511
- CS4512-CS4519
- CS4520-CS4527
- CS4528-CS4535
- CS4536-CS4543
- CS4544-CS4551
- CS4552-CS4559
- CS4560-CS4567
- CS4568-CS4575
- CS4576-CS4583
- CS4584-CS4591
- CS4592-CS4599
- CS4600-CS4607
- CS4608-CS4615
- CS4616-CS4623
- CS4624-CS4631
- CS4632-CS4639
- CS4640-CS4647
- CS4648-CS4655
- CS4656-CS4663
- CS4664-CS4671
- CS4672-CS4679
- CS4680-CS4687
- CS4688-CS4695
- CS4696-CS4703
- CS4704-CS4711
- CS4712-CS4719
- CS4720-CS4727
- CS4728-CS4735
- CS4736-CS4743
- CS4744-CS4751
- CS4752-CS4759
- CS4760-CS4767
- CS4768-CS4775
- CS4776-CS4783
- CS4784-CS4791
- CS4792-CS4799
- CS4800-CS4807
- CS4808-CS4815
- CS4816-CS4823
- CS4824-CS4831
- CS4832-CS4839
- CS4840-CS4847
- CS4848-CS4855
- CS4856-CS4863
- CS4864-CS4871
- CS4872-CS4879
- CS4880-CS4887
- CS4888-CS4895
- CS4896-CS4903
- CS4904-CS4911
- CS4912-CS4919
- CS4920-CS4927
- CS4928-CS4935
- CS4936-CS4943
- CS4944-CS4951
- CS4952-CS4959
- CS4960-CS4967
- CS4968-CS4975
- CS4976-CS4983
- CS4984-CS4991
- CS4992-CS4999
- CS5000-CS5007
- CS5008-CS5015
- CS5016-CS5023
- CS5024-CS5031
- CS5032-CS5039
- CS5040-CS5047
- CS5048-CS5055
- CS5056-CS5063
- CS5064-CS5071
- CS5072-CS5079
- CS5080-CS5087
- CS5088-CS5095
- CS5096-CS5103
- CS5104-CS5111
- CS5112-CS5119
- CS5120-CS5127
- CS5128-CS5135
- CS5136-CS5143
- CS5144-CS5151
- CS5152-CS5159
- CS5160-CS5167
- CS5168-CS5175
- CS5176-CS5183
- CS5184-CS5191
- CS5192-CS5199
- CS5200-CS5207
- CS5208-CS5215
- CS5216-CS5223
- CS5224-CS5231
- CS5232-CS5239
- CS5240-CS5247
- CS5248-CS5255
- CS5256-CS5263
- CS5264-CS5271
- CS5272-CS5279
- CS5280-CS5287
- CS5288-CS5295
- CS5296-CS5303
- CS5304-CS5311
- CS5312-CS5319

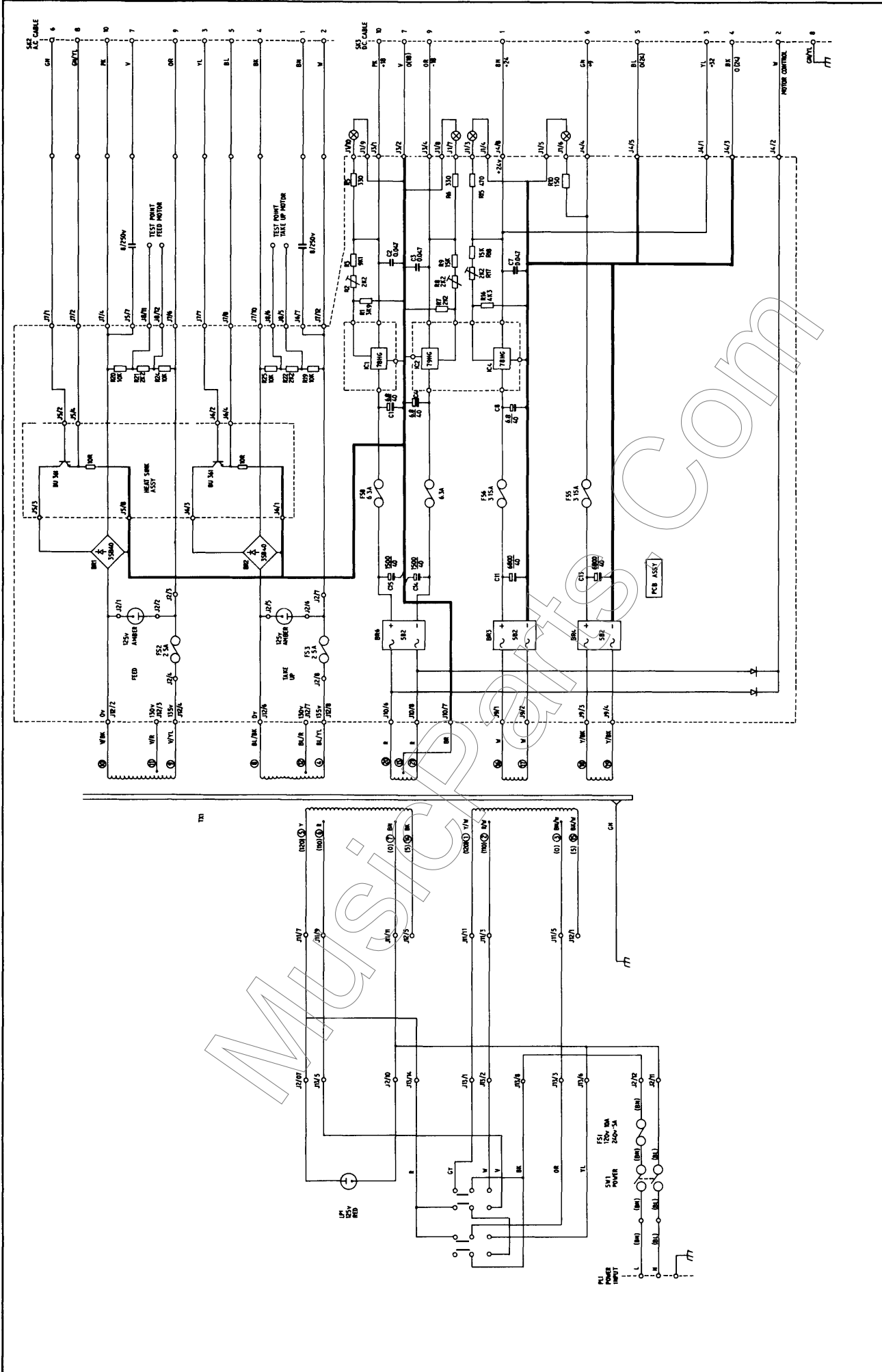

11282 Rev. 1	THIRD ANGLE PROJECTION 	NOTES	TOLERANCE All Imperial dimensions ± 0.01 All metric dimensions ± 0.25mm All angles ± 0.50° Unless otherwise stated	HOLE INDEX	MATERIAL FINISH SCALE	DRW. NO. REV. THROD CHRD T.J.	SOURCECRAFT MAGNETICS LTD 5-8 GREAT SUTTON STREET LONDON EC3N 3JN TELEPHONE 01-251 3639/2/3 TELEGRAMS SOURCECRAFT LON EC3 TELEX UK-NO-27982 USAL-NO-294408	TITLE PSU ASSY SCH 81 CIRCUIT BOARD (LAYER TYPE)	DRWG. NO. 54 3016/2/3
-----------------	---	-------	--	------------	-----------------------------	---	---	---	-----------------------

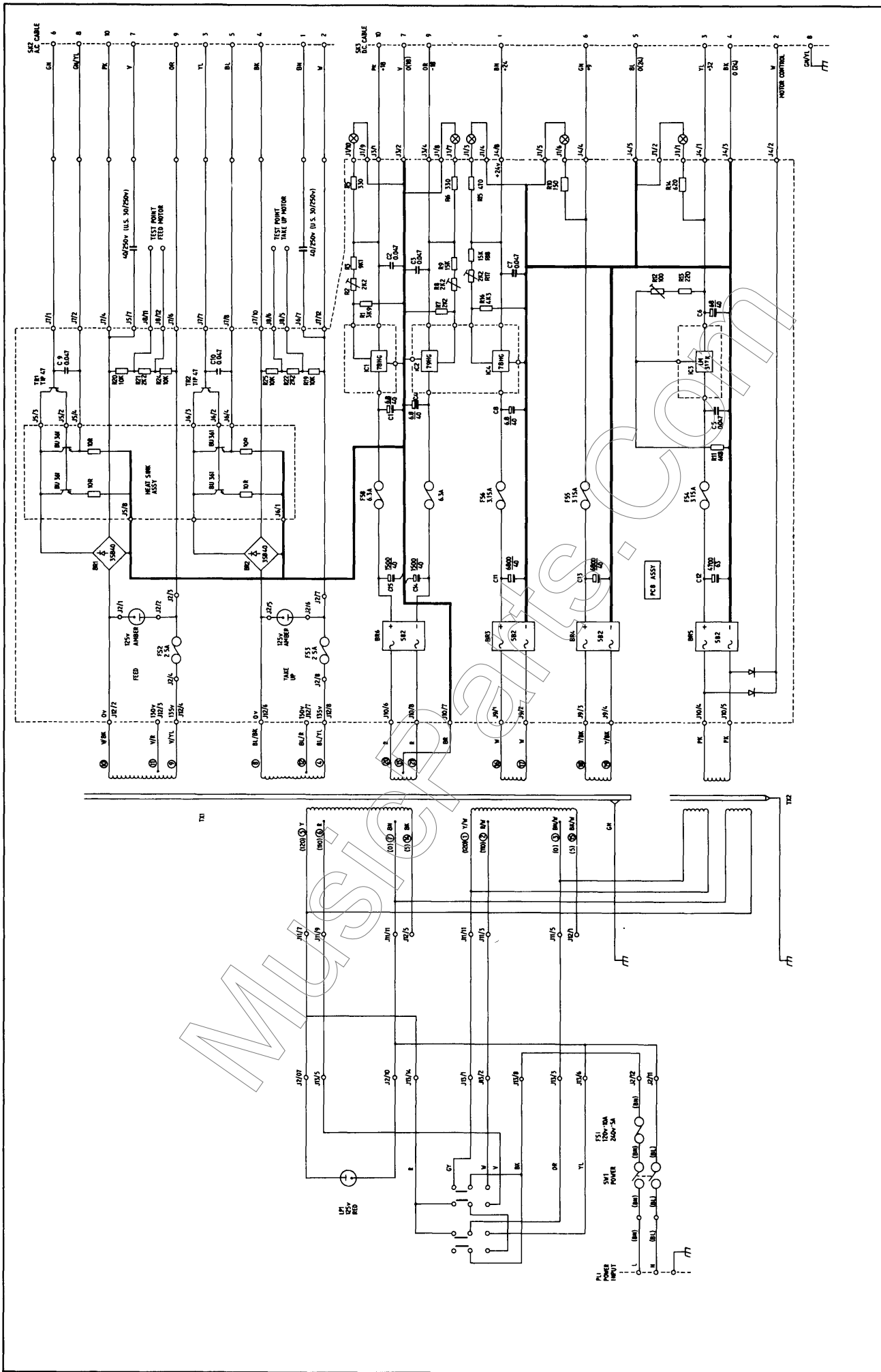

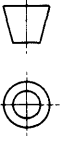
<p>15182 Rev. 1</p>	<p>THIRD ANGLE PROJECTION</p> 	<p>NOTES</p>	<p>TOLERANCE All imperial dimensions: ±0.01 All metric dimensions: ±0.25mm All angles: ±0.50° Unless otherwise stated</p>	<p>HOLE INDEX</p>	<p>MATL FINISH SCALE</p>	<p>DRW R/L TRCD CHKD T J</p>	<p>SOUNDSCRAFT MARINETS LTD 5-8 GREAT SUTTON STREET LONDON EC1V 0BL TELEPHONE 01 251 3631/2/3 TELEGRAMS SOUNDSCRAFT LON EC TELEX UK No 21198 USA No 224408</p>	<p>TITLE SOUNDSCRAFT MARINETS LTD CIRCUIT DIAGRAM SCH 782 DWG No 34 7608</p>
-------------------------	---	--------------	---	-------------------	----------------------------------	--	--	--