

# **Studer D424**

*2-Channel Magneto-Optical Disk Recorder,  
SW Version 1.6*

1. General
2. Operating Elements
3. Quick Start Guide
4. Operation
5. Troubleshooting
6. Circuit Description/Jumper Setting – D424
7. Circuit Description/Jumper Setting – Desktop Controller
8. Diagrams
9. Appendix

Prepared and edited by  
Studer Professional Audio AG  
Technical Documentation  
Althardstrasse 30  
CH-8105 Regensdorf – Switzerland  
<http://www.studer.ch>

Copyright by Studer Professional Audio AG  
Printed in Switzerland  
Order no. 10.27.3811 (Ed. 0202)

Subject to change



To reduce the risk of electric shock, do not remove covers (or back). No user-serviceable parts inside. Refer servicing to qualified service personnel.

Afin de prévenir un choc électrique, ne pas enlever les couvercles (où l'arrière) de l'appareil. Il ne se trouve à l'intérieur aucune pièce pouvant être réparée par l'utilisateur.

Um die Gefahr eines elektrischen Schlags zu vermeiden, entfernen Sie weder Geräteabdeckungen noch Rückwand. Überlassen Sie Wartung und Reparatur qualifiziertem Fachpersonal.

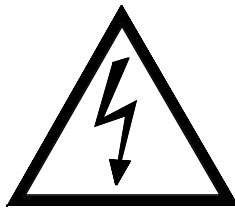

This symbol is intended to alert the user to presence of uninsulated “**dangerous voltage**” within the apparatus that may be of sufficient magnitude to constitute a risk of electric shock to a person.

Ce symbole indique à l'utilisateur qu'il existe à l'intérieur de l'appareil des “**tensions dangereuses**”. Ces tensions élevées ont pour conséquence un risque de choc électrique en cas de contact.

Dieses Symbol deutet dem Anwender an, dass im Geräteinnern die Gefahr der Berührung von “**gefährlicher Spannung**” besteht. Die Höhe der Spannung kann zu einem elektrischen Schlag führen.



This symbol is intended to alert the user to the presence of **important instructions** for operating and maintenance in the enclosed documentation.

Ce symbole indique à l'utilisateur que la documentation jointe contient **d'importantes instructions** concernant le fonctionnement et la maintenance.

Dieses Symbol deutet dem Anwender an, dass die beigelegte Dokumentation **wichtige Hinweise** für Betrieb und Wartung enthält.

- CAUTION:
- ATTENTION:
- ACHTUNG:
- ADVARSEL:

Lithium battery. Danger of explosion by incorrect handling. Replace by battery of the same make and type only.

Pile au lithium. Danger d'explosion en cas de manipulation incorrecte. Ne remplacer que par un modèle de même type.

Explosionsgefahr bei unsachgemäßem Auswechseln der Lithium-batterie. Nur durch den selben Typ ersetzen.

Lithiumbatteri. Eksplosionsfare. Udskiftning må kun foretages af en sagkyndig og som beskrevet i servicemanualen (DK).

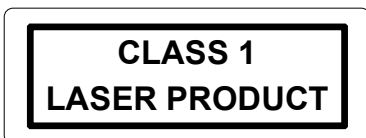

Assemblies or sub-assemblies of this product can contain optoelectronic devices. As long as these devices comply with Class 1 of laser or LED product according to EN 60825-1:1994, they will not be expressly marked on the product. If a special design should be covered by a higher class of this standard, the device concerned will be marked directly on the assembly or sub-assembly in accordance with the above standard.

Baugruppen oder Unterbaugruppen dieses Produktes können optoelektronische Komponenten enthalten. Solange diese der Klasse 1 für Laser- oder LED-Produkte nach der Norm EN 60825-1:1994 entsprechen, sind sie nicht direkt am Gerät bezeichnet. Sollte eine Sonderausführung in eine höhere Klasse fallen, so ist die betreffende Baugruppe oder Unterbaugruppe gemäß dieser Norm mit entsprechender Aufschrift versehen.

**FIRST AID**

(in case of electric shock)

1. Separate the person as quickly as possible from the electric power source:
  - by switching off the equipment
  - or by unplugging or disconnecting the mains cable
  - pushing the person away from the power source by using dry insulating material (such as wood or plastic).
  - *After having sustained an electric shock, always consult a doctor.*

**WARNING!**

DO NOT TOUCH THE PERSON OR HIS CLOTHING BEFORE THE POWER IS TURNED OFF, OTHERWISE YOU STAND THE RISK OF SUSTAINING AN ELECTRIC SHOCK AS WELL!

2. If the person is unconscious:
  - check the pulse,
  - reanimate the person if respiration is poor,
  - lay the body down, turn it to one side, call for a doctor immediately.

**PREMIERS SECOURS**

(en cas d'électrocution)

1. Si la personne est dans l'impossibilité de se libérer:
  - Couper l'interrupteur principal
  - Couper le courant
  - Repousser la personne de l'appareil à l'aide d'un objet en matière non conductrice (matière plastique ou bois)
  - *Après une électrocution, toujours consulter un médecin.*

**ATTENTION!**

NE JAMAIS TOUCHER UNE PERSONNE QUI EST SOUS TENSION, SOUS PEINE DE SUBIR EGLEMENT UNE ELECTROCUTION.

2. En cas de perte de connaissance de la personne électrocutée:
  - Contrôler le pouls
  - Si nécessaire, pratiquer la respiration artificielle
  - Placer l'accidenté sur le flanc et consulter un médecin.

**ERSTE HILFE**

(bei Stromunfällen)

1. Bei einem Stromunfall die betroffene Person so rasch wie möglich vom Strom trennen:
  - Ausschalten des Gerätes
  - Ziehen oder Unterbrechen der Netzzuleitung
  - Betroffene Person mit isoliertem Material (Holz, Kunststoff) von der Gefahrenquelle wegstossen
  - *Nach einem Stromunfall sollte immer ein Arzt aufgesucht werden.*

**ACHTUNG!**

EINE UNTER SPANNUNG STEHENDE PERSON DARF NICHT BERÜHRT WERDEN. SIE KÖNNEN DABEI SELBST ELEKTRISIERT WERDEN!

2. Bei Bewusstlosigkeit des Verunfallten:
  - Puls kontrollieren,
  - bei ausgesetzter Atmung künstlich beatmen,
  - Seitenlagerung des Verunfallten vornehmen und Arzt verständigen.

**Installation**

Vor der Installation des Gerätes müssen die hier aufgeführten und auch die weiter in dieser Anleitung mit ⚠ bezeichneten Hinweise gelesen und während der Installation und des Betriebes beachtet werden.

Untersuchen Sie das Gerät und sein Zubehör auf allfällige Transportschäden.

Ein Gerät, das mechanische Beschädigung aufweist oder in welches Flüssigkeit oder Gegenstände eingedrungen sind, darf nicht ans Netz angeschlossen oder muss sofort durch Ziehen des Netzsteckers vom Netz getrennt werden. Das Öffnen und Instandsetzen des Gerätes darf nur von Fachpersonal unter Einhaltung der geltenden Vorschriften durchgeführt werden.

Liegt dem Gerät kein konfektioniertes Netzkabel bei, so muss dieses durch eine Fachperson unter Verwendung der mitgelieferten Kabel-Gerätedose IEC320/C13 oder IEC320/C19 und unter Berücksichtigung der einschlägigen, im jeweiligen Lande geltenden Bestimmungen angefertigt werden; siehe unten.

Vor Anschluss des Netzkabels an die Netzsteckdose muss überprüft werden, ob die Stromversorgungs- und Anschlusswerte des Gerätes (Netzspannung, Netzfrequenz) innerhalb der erlaubten Toleranzen liegen. Die im Gerät eingesetzten Sicherungen müssen den am Gerät angebrachten Angaben entsprechen.

Ein Gerät mit einem dreipoligen Gerätestecker (Gerät der Schutzklasse I) muss an eine dreipolige Netzsteckdose angeschlossen und somit das Gerätegehäuse mit dem Schutzleiter der Netzinstallation verbunden werden (Für Dänemark gelten Starkstrombestimmungen, Abschnitt 107).

**Installation**

Before you install the equipment, please read and adhere to the following recommendations and all sections of these instructions marked with ⚠.

Check the equipment for any transport damage.

A unit that is mechanically damaged or which has been penetrated by liquids or foreign objects must not be connected to the AC power outlet or must be immediately disconnected by unplugging the power cable. Repairs must only be performed by trained personnel in accordance with the applicable regulations.

Should the equipment be delivered without a matching mains cable, the latter has to be prepared by a trained person using the attached female plug (IEC320/C13 or IEC320/C19) with respect to the applicable regulations in your country - see diagram below.

Before connecting the equipment to the AC power outlet, check that the local line voltage matches the equipment rating (voltage, frequency) within the admissible tolerance. The equipment fuses must be rated in accordance with the specifications on the equipment.

Equipment supplied with a 3-pole appliance inlet (equipment conforming to protection class I) must be connected to a 3-pole AC power outlet so that the equipment cabinet is connected to the protective earth conductor of the AC supply (for Denmark the Heavy Current Regulations, Section 107, are applicable).

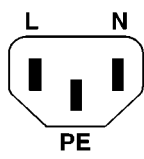
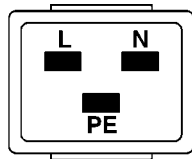
 <p><b>IEC 320 / C13</b></p>	 <p><b>IEC 320 / C19</b></p>
Female plug (IEC320), view from contact side: L live; brown N neutral; blue PE protective earth; green and yellow	National American Standard: Black White green
Connecteur femelle (IEC320), vue de la face aux contacts: L phase; brun N neutre; bleu PE terre protectrice; vert et jaune	Standard national américain: Noir Blanc Vert
Ansicht auf Steckkontakte der Kabel-Gerätesteckdose (IEC320): L Phase; braun N Nulleiter; blau PE Schutzleiter; gelb/grün	USA-Standard: Schwarz Weiss grün

### Zugentlastung für den Netzanschluss

Zum Verankern von Steckverbindungen ohne mechanische Verriegelung (z.B. IEC-Kaltgerätedosen) empfehlen wir die folgende Anordnung:

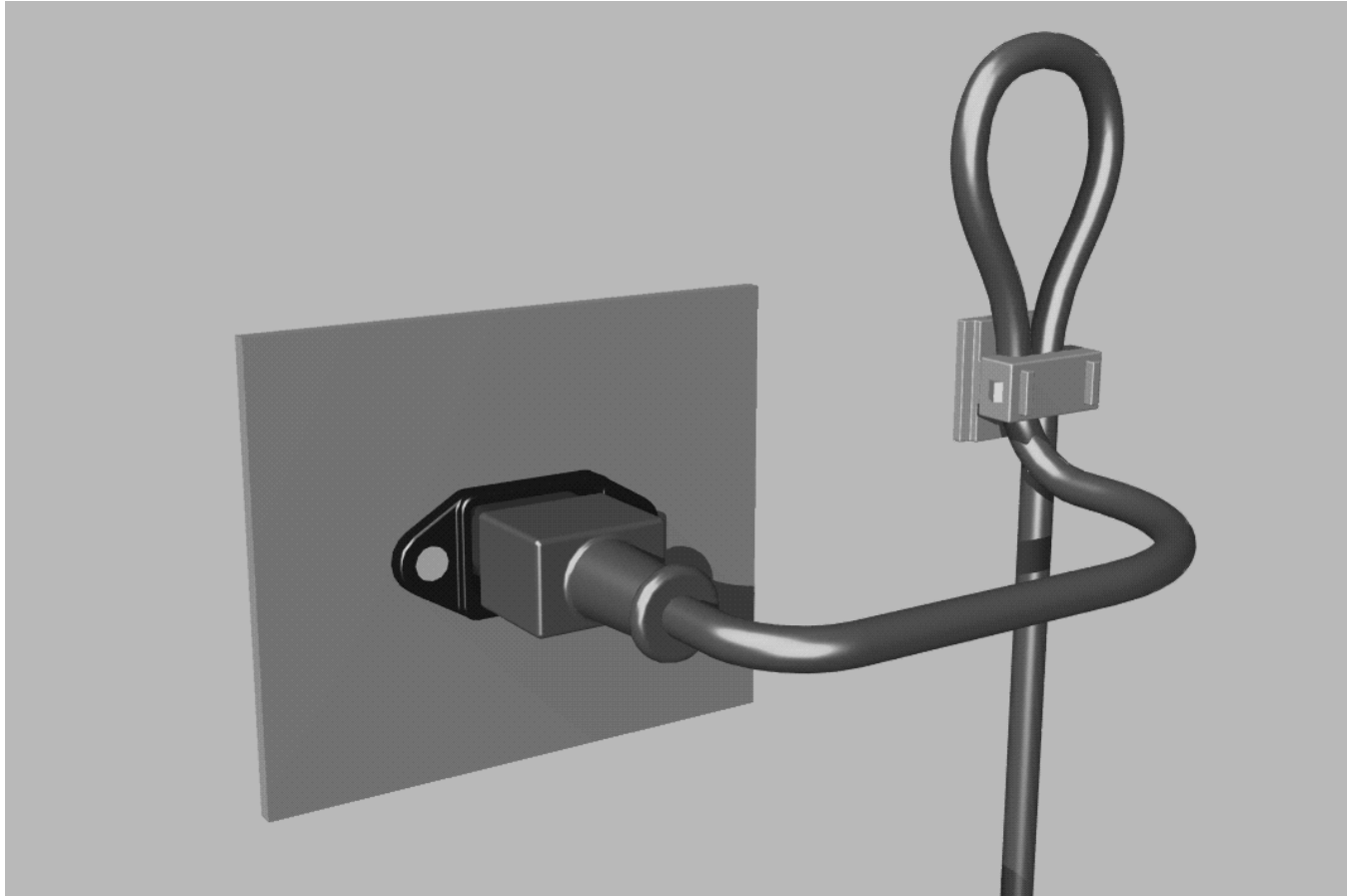

### Mains connector strain relief

For anchoring connectors without a mechanical lock (e.g. IEC mains connectors), we recommend the following arrangement:

Vorgehen: Der mitgelieferte Kabelhalter ist selbstklebend. Bitte beachten Sie bei der Montage die folgenden Regeln:

1. Der Untergrund muss sauber, trocken und frei von Fett, Öl und anderen Verunreinigungen sein. Temperaturbereich für optimale Verklebung: 20...40° C.
2. Entfernen Sie die Schutzfolie auf der Rückseite des Kabelhalters und bringen sie ihn mit kräftigem Druck an der gewünschten Stelle an. Lassen sie ihn unbelastet so lange wie möglich ruhen – die maximale Klebekraft ist erst nach rund 24 Stunden erreicht.
3. Die Stabilität des Kabelhalters wird erhöht, wenn Sie ihn zusätzlich verschrauben. Zu diesem Zweck liegen ihm eine selbstschneidende Schraube sowie eine M4-Schraube mit Mutter bei.
4. Legen Sie das Kabel gemäss Figur in den Halter ein und pressen Sie die Klemme kräftig auf, bis das Kabel fixiert ist.

Procedure: The cable clamp shipped with your unit is auto-adhesive. If mounting, please follow the rules below:

1. The surface to be adhered to must be clean, dry, and free from grease, oil or other contaminants. Best application temperature range is 20...40° C.
2. Remove the plastic protective backing from the rear side of the clamp and apply it firmly to the surface at the desired position. Allow as much time as possible for curing. The bond continues to develop for as long as 24 hours.
3. For improved stability, the clamp can be fixed with a screw. For this purpose, a self-tapping screw and an M4 bolt and nut are included.
4. Place the cable into the clamp as shown in the illustration above and firmly press down the internal top cover until the cable is fixed.

## Lufttemperatur und Feuchtigkeit

### Allgemein

Die Betriebstauglichkeit des Gerätes oder Systems ist unter folgenden Umgebungsbedingungen gewährleistet:

*EN 60721-3-3, Set IE32, Wert 3K3.*

Diese Norm besteht aus einem umfassenden Katalog von Parametern; die wichtigsten davon sind: Umgebungstemperatur +5...+40 °C; rel. Luftfeuchtigkeit 5...85% – d.h. weder Kondensation noch Eisbildung; abs. Luftfeuchtigkeit 1...25 g/m<sup>3</sup>; Temperatur-Änderungsrate < 0,5 °C/min. In den folgenden Abschnitten wird darauf näher eingegangen.

Unter den genannten Bedingungen startet und arbeitet das Gerät oder System problemlos. Ausserhalb dieser Spezifikationen möglicherweise auftretende Probleme sind in den folgenden Abschnitten beschrieben.

### Umgebungstemperatur

Geräte und Systeme von Studer sind allgemein für einen Umgebungs-Temperaturbereich (d.h. Temperatur der eintretenden Kühlluft) von +5...+40 °C ausgelegt. Bei Installation in einem Schrank muss der vorgesehene Luftdurchsatz und dadurch die Konvektionskühlung gewährleistet sein. Folgende Tatsachen sind dabei zu berücksichtigen:

1. Die zulässige Umgebungstemperatur für den Betrieb der Halbleiter-Bauelemente beträgt 0 °C bis +70 °C (commercial temperature range for operation).
2. Der Luftdurchsatz der Anlage muss gewährleisten, dass die austretende Kühlluft ständig kühler ist als 70 °C.
3. Die mittlere Erwärmung der Kühlluft soll 20 K betragen, die maximale Erwärmung an den heissen Komponenten darf somit um weitere 10 K höher liegen.
4. Zum Abführen einer Verlustleistung von 1 kW bei dieser zulässigen mittleren Erwärmung ist eine Luftmenge von 2,65 m<sup>3</sup>/min notwendig.

**Beispiel:** Für ein Rack mit einer Leistungsaufnahme  $P = 800 \text{ W}$  ist eine Kühlluftmenge von  $0,8 * 2,65 \text{ m}^3/\text{min}$  nötig, entsprechend  $2,12 \text{ m}^3/\text{min}$ .

5. Soll die Kühlfunktion der Anlage (z.B. auch bei Lüfter-Ausfall oder Bestrahlung durch Spotlampen) überwacht werden, so ist die Temperatur der Abluft unmittelbar oberhalb der Einschübe an mehreren Stellen im Rack zu messen; die Ansprechtemperatur der Sensoren soll 65 bis 70 °C betragen.

### Reif und Tau

Das unversiegelte System (Steckerpartien, Halbleiteranschlüsse) verträgt zwar leichte Eisbildung (Reif). Mit blossen Auge sichtbare Betauung führt jedoch bereits zu Funktionsstörungen. In der Praxis kann mit einem zuverlässigen Betrieb der Geräte bereits im Temperaturbereich ab -15 °C gerechnet werden, wenn für die Inbetriebnahme des kalten Systems die folgende allgemeine Regel beachtet wird:

Wird die Luft im System abgekühlt, so steigt ihre relative Feuchtigkeit an. Erreicht diese 100%, kommt es zu Niederschlag, meist in der Grenzschicht zwischen der Luft und einer kühleren Oberfläche, und somit zur Bildung von Eis oder Tau an empfindlichen Systemstellen (Kontakte, IC-Anschlüsse etc.). Ein störungsfreier Betrieb mit interner Betauung, unabhängig von der Temperatur, ist nicht gewährleistet.

## Air temperature and humidity

### General

Normal operation of the unit or system is warranted under the following ambient conditions defined by:

*EN 60721-3-3, set IE32, value 3K3.*

This standard consists of an extensive catalogue of parameters, the most important of which are: ambient temperature +5...+40° C, relative humidity 5...85% – i.e. no formation of condensation or ice; absolute humidity 1...25 g/m<sup>3</sup>; rate of temperature change < 0,5 °C/min. These parameters are dealt with in the following paragraphs.

Under these conditions the unit or system starts and works without any problem. Beyond these specifications, possible problems are described in the following sections.

### Ambient temperature

Units and systems by Studer are generally designed for an ambient temperature range (i.e. temperature of the incoming air) of +5...+40 °C. When rack mounting the units, the intended air flow and herewith adequate cooling must be provided. The following facts must be considered:

1. The admissible ambient temperature range for operation of the semiconductor components is 0 °C to +70 °C (commercial temperature range for operation).
2. The air flow through the installation must provide that the outgoing air is always cooler than 70 °C.
3. Average heat increase of the cooling air shall be 20 K, allowing for an additional maximum 10 K increase at the hot components.
4. In order to dissipate 1 kW with this admissible average heat increase, an air flow of 2,65 m<sup>3</sup>/min is required.

**Example:** A rack dissipating  $P = 800 \text{ W}$  requires an air flow of  $0,8 * 2,65 \text{ m}^3/\text{min}$  which corresponds to  $2,12 \text{ m}^3/\text{min}$ .

5. If the cooling function of the installation must be monitored (e.g. for fan failure or illumination with spot lamps), the outgoing air temperature must be measured directly above the modules at several places within the rack. The trigger temperature of the sensors should be 65 to 70 °C.

### Frost and dew

The unsealed system parts (connector areas and semiconductor pins) allow for a minute formation of ice or frost. However, formation of dew visible with the naked eye will already lead to malfunctions. In practice, reliable operation can be expected in a temperature range above -15 °C, if the following general rule is considered for putting the cold system into operation:

If the air within the system is cooled down, the relative humidity rises. If it reaches 100%, condensation will arise, usually in the boundary layer between the air and a cooler surface, together with formation of ice or dew at sensitive areas of the system (contacts, IC pins, etc.). Once internal condensation occurs, trouble-free operation cannot be guaranteed, independent of temperature.

Vor der Inbetriebnahme muss das System auf allfällige interne Btauung oder Eisbildung überprüft werden. Nur bei sehr leichter Eisbildung kann mit direkter Verdunstung (Sublimation) gerechnet werden; andernfalls muss das System im abgeschalteten Zustand gewärmt und getrocknet werden.

Das System ohne feststellbare interne Eisbildung oder Btauung soll möglichst homogen (und somit langsam) mit eigener Wärmeleistung aufgewärmt werden; die Lufttemperatur der Umgebung soll ständig etwas tiefer als diejenige der Systemluft sein.

Ist es unumgänglich, das abgekühlte System sofort in warmer Umgebungsluft zu betreiben, so muss diese entfeuchtet sein. Die absolute Luftfeuchtigkeit muss dabei so tief sein, dass die relative Feuchtigkeit, bezogen auf die kälteste Oberfläche im System, immer unterhalb 100% bleibt.

Es ist dafür zu sorgen, dass beim Abschalten des Systems die eingeschlossene Luft möglichst trocken ist (d.h. vor dem Abschalten im Winter den Raum mit kalter, trockener Luft belüften und feuchte Gegenstände, z.B. Kleider, entfernen).

Die Zusammenhänge sind im folgenden Klimatogramm ersichtlich. Zum kontrollierten Verfahren gehören Thermometer und Hygrometer sowie ein Thermometer im System.

**Beispiel 1:** Ein Ü-Wagen mit einer Innentemperatur von 20 °C und 40% relativer Luftfeuchtigkeit wird am Abend abgeschaltet. Sinkt die Temperatur unter +5 °C, bildet sich Tau oder Eis.

**Beispiel 2:** Ein Ü-Wagen wird morgens mit 20 °C warmer Luft von 40% relativer Luftfeuchtigkeit aufgewärmt. Auf Teilen, die kälter als +5 °C sind, bildet sich Tau oder Eis.

Before putting into operation, the system must be checked for internal formation of condensation or ice. Only with a minute formation of ice, direct evaporation (sublimation) may be expected; otherwise the system must be heated and dried while switched off.

A system without visible internal formation of ice or condensation should be heated up with its own heat dissipation, as homogeneously (and subsequently as slow) as possible; the ambient temperature should then always be lower than the outgoing air.

If it is absolutely necessary to operate the system immediately within warm ambient air, this air must be dehydrated. In such a case, the absolute humidity must be so low that the relative humidity, related to the coldest system surface, always remains below 100%.

Ensure that the enclosed air is as dry as possible when powering off (i.e. before switching off in winter, aerate the room with cold, dry air, and remove humid objects as clothes from the room).

These relationships are visible from the following climatogram. For a controlled procedure, thermometer and hygrometer as well as a thermometer within the system will be required.

**Example 1:** An OB-van having an internal temperature of 20 °C and rel. humidity of 40% is switched off in the evening. If temperature falls below +5 °C, dew or ice will be forming.

**Example 2:** An OB-van is heated up in the morning with air of 20 °C and a rel. humidity of 40%. On all parts being cooler than +5 °C, dew or ice will be forming.

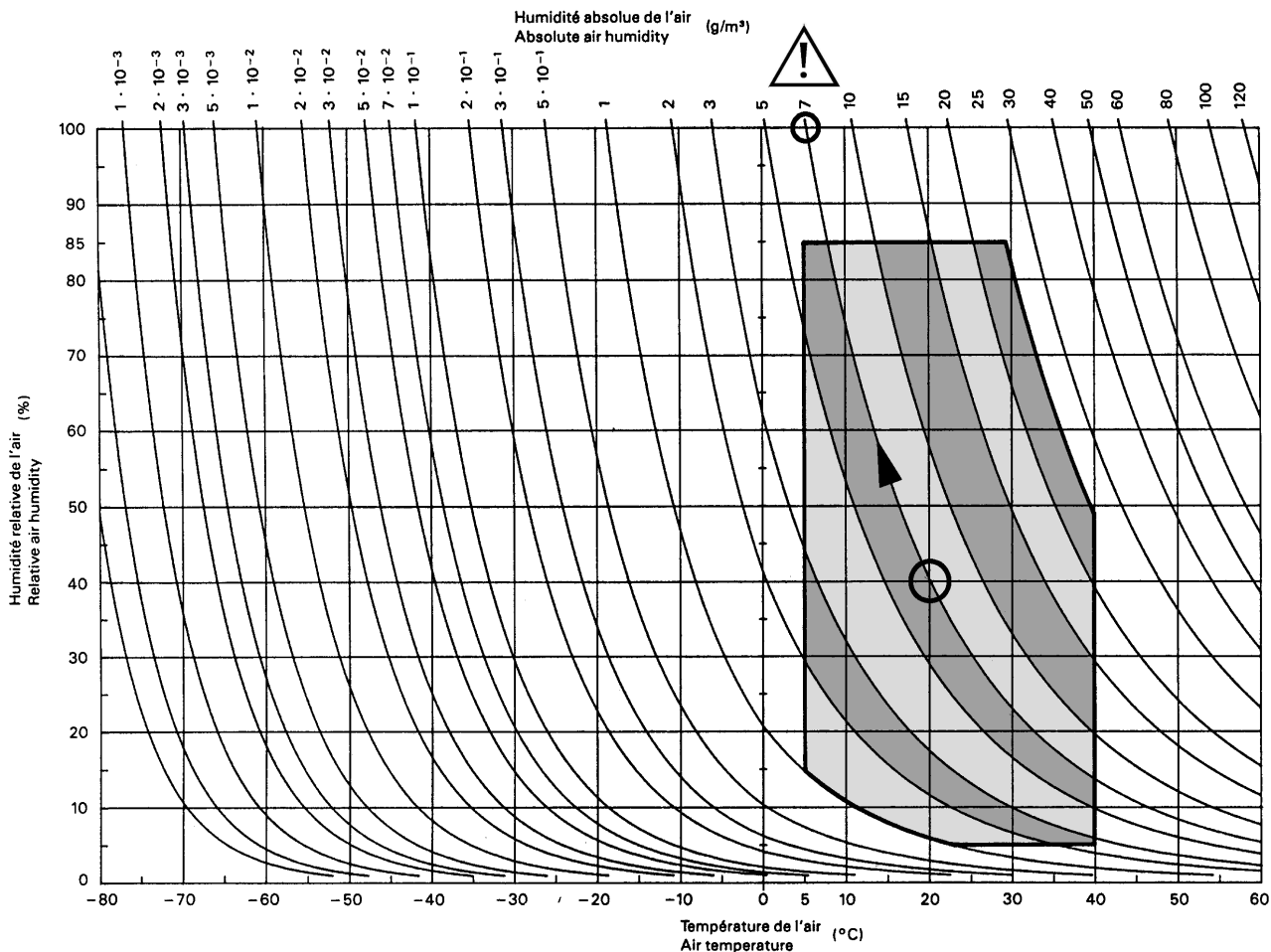

Figure B.3 – Climatogramme pour catégorie 3K3  
Climatogram for class 3K3



## Wartung und Reparatur

Durch Entfernen von Gehäuseteilen, Abschirmungen etc. werden stromführende Teile freigelegt. Deshalb müssen u.a. die folgenden Grundsätze beachtet werden:

Eingriffe in das Gerät dürfen nur von Fachpersonal unter Einhaltung der geltenden Vorschriften vorgenommen werden.

Vor Entfernen von Gehäuseteilen muss das Gerät ausgeschaltet und vom Netz getrennt werden.

Bei geöffnetem, vom Netz getrenntem Gerät dürfen Teile mit gefährlichen Ladungen (z. B. Kondensatoren, Bildröhren) erst nach kontrollierter Entladung, heiße Bauteile (Leistungshalbleiter, Kühlkörper etc.) erst nach deren Abkühlen berührt werden.

Bei Wartungsarbeiten am geöffneten, unter Netzspannung stehenden Gerät dürfen blanke Schaltungsteile und metallene Halbleitergehäuse weder direkt noch mit nichtisoliertem Werkzeug berührt werden.

Zusätzliche Gefahren bestehen bei unsachgemäßer Handhabung besonderer Komponenten:

- *Explosionsgefahr* bei Lithiumzellen, Elektrolyt-Kondensatoren und Leistungshalbleitern
- *Implosionsgefahr* bei evakuierten Anzeigeeinheiten
- *Strahlungsgefahr* bei Lasereinheiten (nichtionisierend), Bildröhren (ionisierend)
- *Verätzungsgefahr* bei Anzeigeeinheiten (LCD) und Komponenten mit flüssigem Elektrolyt.

*Solche Komponenten dürfen nur von ausgebildetem Fachpersonal mit den vorgeschriebenen Schutzmitteln (u.a. Schutzbrille, Handschuhe) gehandhabt werden.*

## Maintenance and Repair

The removal of housing parts, shields, etc. exposes energized parts. For this reason the following precautions should be observed:

Maintenance should only be performed by trained personnel in accordance with the applicable regulations.

The equipment should be switched off and disconnected from the AC power outlet before any housing parts are removed.

Even if the equipment is disconnected from the power, parts with hazardous charges (e.g. capacitors, picture tubes) must not be touched until they have been properly discharged. Touch hot components (power semiconductors, heat sinks, etc.) only when cooled off.

If maintenance is performed on a unit that is opened and switched on, no uninsulated circuit components and metallic semiconductor housings must be touched neither with your bare hands nor with uninsulated tools.

Certain components pose additional hazards:

- *Explosion hazard* from lithium batteries, electrolytic capacitors and power semiconductors
- *Implosion hazard* from evacuated display units
- *Radiation hazard* from laser units (non-ionizing), picture tubes (ionizing)
- *Caustic effect* of display units (LCD) and such components containing liquid electrolyte.

*Such components should only be handled by trained personnel who are properly protected (e.g. safety goggles, gloves).*

## Elektrostatische Entladung (ESD) bei Wartung und Reparatur

## Electrostatic Discharge (ESD) during Maintenance and Repair



<b>ATTENTION:</b>	Observe precautions for handling devices sensitive to electrostatic discharge!
<b>ATTENTION:</b>	Respecter les précautions d'usage concernant la manipulation de composants sensibles à l'électricité statique!
<b>ACHTUNG:</b>	Vorsichtsmassnahmen bei der Handhabung von ESD-empfindlichen Bauelementen beachten!

Viele ICs und andere Halbleiter sind empfindlich gegen elektrostatische Entladung (ESD). Unsachgemässe Behandlung von Baugruppen mit solchen Komponenten bei Wartung und Reparatur kann deren Lebensdauer drastisch vermindern.

Bei der Handhabung der ESD-empfindlichen Komponenten sind u.a. folgende Regeln zu beachten:

- ESD-empfindliche Komponenten dürfen ausschliesslich in dafür bestimmten und bezeichneten Verpackungen gelagert und transportiert werden.
- Unverpackte, ESD-empfindliche Komponenten dürfen nur in dafür eingerichteten Schutzzonen (EPA, z.B. Gebiet für Feldservice, Reparatur- oder Serviceplatz) gehandhabt und nur von Personen berührt werden, die durch ein Handgelenkband mit Serienwiderstand mit dem Massepotential des Reparatur- oder Serviceplatzes verbunden sind. Das gewartete Gerät wie auch Werkzeug, Hilfsmittel, EPA-taugliche (elektrisch halbleitende) Arbeits-, Ablage- und Bodenmatten müssen ebenfalls mit diesem Potential verbunden sein.
- Die Anschlüsse der ESD-empfindlichen Komponenten dürfen unkontrolliert weder mit elektrostatisch aufladbaren (Gefahr von Spannungsdurchschlag), noch mit metallischen Oberflächen (Schockentladungsgefahr) in Berührung kommen.
- Um undefinierte transiente Beanspruchung der Komponenten und deren eventuelle Beschädigung durch unerlaubte Spannung oder Ausgleichsströme zu vermeiden, dürfen elektrische Verbindungen nur am abgeschalteten Gerät und nach dem Abbau allfälliger Kondensatorladungen hergestellt oder getrennt werden.

Many ICs and semiconductors are sensitive to electrostatic discharge (ESD). The life of components containing such elements can be drastically reduced by improper handling during maintenance and repair work.

Please observe the following rules when handling ESD sensitive components:

- ESD sensitive components should only be stored and transported in the packing material specifically provided for this purpose.
- Unpacked ESD sensitive components should only be handled in ESD protected areas (EPA, e.g. area for field service, repair or service bench) and only be touched by persons who wear a wristlet that is connected to the ground potential of the repair or service bench by a series resistor. The equipment to be repaired or serviced and all tools, aids, as well as electrically semi-conducting work, storage and floor mats should also be connected to this ground potential.
- The terminals of ESD sensitive components must not come in uncontrolled contact with electrostatically chargeable (voltage puncture) or metallic surfaces (discharge shock hazard).
- To prevent undefined transient stress of the components and possible damage due to inadmissible voltages or compensation currents, electrical connections should only be established or separated when the equipment is switched off and after any capacitor charges have decayed.

**SMD-Bauelemente**

Der Austausch von SMD-Bauelementen ist ausschliesslich geübten Fachleuten vorbehalten. Für verwüstete Platinen können keine Ersatzansprüche geltend gemacht werden. Beispiele für korrekte und falsche SMD-Lötverbindungen in der Abbildung weiter unten.

Bei Studer werden keine handelsüblichen SMD-Bauteile bewirtschaftet. Für Reparaturen sind die notwendigen Bauteile lokal zu beschaffen. Die Spezifikationen von Spezialbauteilen finden Sie in der Serviceanleitung.

**SMD Components**

SMD components should only be replaced by skilled specialists. No warranty claims will be accepted for circuit boards that have been ruined. Proper and improper SMD soldering joints are depicted below.

Studer does not keep any commercially available SMD components in stock. For repair the corresponding devices should be purchased locally. The specifications of special components can be found in the service manual.

		<p>LötKolben/Soldering iron</p>	
<p><b>Demontage/Dismounting</b></p>			
<p><b>Montage/Mounting</b></p>		<p><b>Beispiele/Examples</b></p>	

## Störstrahlung und Störfestigkeit

Das Gerät entspricht den Schutzanforderungen auf dem Gebiet elektromagnetischer Phänomene, wie u.a. in den Richtlinien 89/336/EWG und FCC, Part 15, aufgeführt:

1. Vom Gerät erzeugte elektromagnetische Strahlung ist soweit begrenzt, dass bestimmungsgemässer Betrieb anderer Geräte und Systeme möglich ist.
2. Das Gerät weist eine angemessene Festigkeit gegen elektromagnetische Störungen auf, so dass sein bestimmungsgemässer Betrieb möglich ist.

Das Gerät wurde getestet und erfüllt die Bedingungen der im Kapitel „Technische Daten“ aufgeführten EMV-Normen. Die Limiten dieser Standards gewährleisten mit angemessener Wahrscheinlichkeit sowohl den Schutz der Umgebung wie auch entsprechende Störfestigkeit des Gerätes. Absolute Garantie, dass keine unerlaubte elektromagnetische Beeinträchtigung während des Betriebes entsteht, ist jedoch nicht gegeben.

Um die Wahrscheinlichkeit solcher Beeinträchtigung weitgehend auszuschliessen, sind u.a. folgende Massnahmen zu beachten:

- Installieren Sie das Gerät gemäss den Angaben in der Betriebsanleitung, und verwenden Sie das mitgelieferte Zubehör.
- Verwenden Sie im System und in der Umgebung, in denen das Gerät eingesetzt ist, nur Komponenten (Anlagen, Geräte), die ihrerseits die Anforderungen der obenerwähnten Standards erfüllen.
- Sehen Sie ein Erdungskonzept des Systems vor, das sowohl die Sicherheitsanforderungen (die Erdung der Geräte gemäss Schutzklasse I mit einem Schutzleiter muss gewährleistet sein), wie auch die EMV-Belange berücksichtigt. Bei der Entscheidung zwischen stern- oder flächenförmiger bzw. kombinierter Erdung sind Vor- und Nachteile gegeneinander abzuwägen.
- Benutzen Sie abgeschirmte Kabel, wo vorgesehen. Achten Sie auf einwandfreie, grossflächige, korrosionsbeständige Verbindung der Abschirmung zum entsprechenden Steckeranschluss und dessen Gehäuse. Beachten Sie, dass eine nur an einem Ende angeschlossene Kabelabschirmung als Sende- bzw. Empfangsantenne wirken kann (z.B. bei wirksamer Kabellänge von 5 m oberhalb von 10 MHz), und dass die Flanken digitaler Kommunikationssignale hochfrequente Aussendungen verursachen (z.B. LS- oder HC-Logik bis 30 MHz).
- Vermeiden Sie Bildung von Masseschleifen oder vermindern Sie deren unerwünschte Auswirkung, indem Sie deren Fläche möglichst klein halten und den darin fließenden Strom durch Einfügen einer Impedanz (z.B. Gleichtaktdrossel) reduzieren.

## Electromagnetic Compatibility

The equipment conforms to the protection requirements relevant to electromagnetic phenomena that are listed in the guidelines 89/336/EC and FCC, part 15.

1. The electromagnetic interference generated by the equipment is limited in such a way that other equipment and systems can be operated normally.
2. The equipment is adequately protected against electromagnetic interference so that it can operate correctly.

The unit has been tested and conforms to the EMC standards applicable to residential, commercial and light industry, as listed in the section „Technical Data“. The limits of these standards reasonably ensure protection of the environment and corresponding noise immunity of the equipment. However, it is not absolutely warranted that the equipment will not be adversely affected by electromagnetic interference during operation.

To minimize the probability of electromagnetic interference as far as possible, the following recommendations should be followed:

- Install the equipment in accordance with the operating instructions. Use the supplied accessories.
- In the system and in the vicinity where the equipment is installed, use only components (systems, equipment) that also fulfill the above EMC standards.
- Use a system grounding concept that satisfies the safety requirements (protection class I equipment must be connected with a protective ground conductor) that also takes into consideration the EMC requirements. When deciding between radial, surface or combined grounding, the advantages and disadvantages should be carefully evaluated in each case.
- Use shielded cables where shielding is specified. The connection of the shield to the corresponding connector terminal or housing should have a large surface and be corrosion-proof. Please note that a cable shield connected only single-ended can act as a transmitting or receiving antenna (e.g. with an effective cable length of 5 m, the frequency is above 10 MHz) and that the edges of the digital communication signals cause high-frequency radiation (e.g. LS or HC logic up to 30 MHz).
- Avoid ground loops or reduce their adverse effects by keeping the loop surface as small as possible, and reduce the noise current flowing through the loop by inserting an additional impedance (e.g. common-mode rejection choke).

## Class A Equipment - FCC Notice

This equipment has been tested and found to comply with the limits for a Class A digital device, pursuant to Part 15 of the FCC Rules. These limits are designed to provide a reasonable protection against harmful interference when the equipment is operated in a commercial environment. This equipment generates, uses, and can radiate radio frequency energy and, if not installed and used in accordance with the instruction manual, may cause harmful interference to radio communications. Operation of this equipment in a residential

area is likely to cause harmful interference in which case the user will be required to correct the interference at his own expense.

*Caution:*

*Any changes or modifications not expressly approved by the manufacturer could void the user's authority to operate the equipment. Also refer to relevant information in this manual.*

## CE-Konformitätserklärung

Der Hersteller,

Studer Professional Audio AG,  
CH-8105 Regensdorf,

erklärt in eigener Verantwortung, dass das Produkt

**Studer D424, 2-Channel Professional MO-Disk Recorder,  
(ab Serie-Nr. 101),**

auf das sich diese Erklärung bezieht, entsprechend den Bestimmungen der EU-Richtlinien und Ergänzungen

- Elektromagnetische Verträglichkeit (EMV):  
89/336/EWG + 92/31/EWG + 93/68/EWG
- Niederspannung:  
73/23/EWG + 93/68/EWG

mit den folgenden Normen und normativen Dokumenten übereinstimmt:

- Sicherheit:  
Schutzklasse 1, EN 60950:1992 + A1/A2:1993
- EMV:  
EN 50081-1:1992, EN 50082-1:1992

Regensdorf, 18. Juli 1996



B. Hochstrasser, President, International Sales



P. Fiala, Leiter QS

## CE Declaration of Conformity

The manufacturer,

Studer Professional Audio AG,  
CH-8105 Regensdorf,

declares under his sole responsibility that the product

**Studer D424, 2-Channel Professional MO-Disk Recorder,  
(on from serial No. 101),**

to which this declaration relates, according to following regulations of EU directives and amendments

- Electromagnetic Compatibility (EMC):  
89/336/EEC + 92/31/EEC + 93/68/EEC
- Low Voltage (LVD):  
73/23/EEC + 93/68/EEC

is in conformity with the following standards or other normative documents:

- Safety:  
Class 1, EN 60950:1992 + A1/A2:1993
- EMC:  
EN 50081-1:1992, EN 50082-1:1992

Regensdorf, July 18, 1996



B. Hochstrasser, President, International Sales



P. Fiala, Manager QA

# CONTENTS

---

<b>1</b>	<b>General.....</b>	<b>E1/1</b>
1.1	MO Recording .....	E1/1
1.2	The Medium – Magneto-Optical Disks.....	E1/2
1.2.1	Disk Standards .....	E1/2
1.2.2	Disk Formatting .....	E1/3
1.2.3	Disk Capacities .....	E1/3
1.2.4	Disk Handling.....	E1/4
1.3	File Systems, File Formats, Audio Files .....	E1/5
1.3.1	Takes, Indices, and Sequences.....	E1/5
1.3.2	Non-Destructive Editing .....	E1/7
1.4	Utilization for the Purpose Intended .....	E1/8
1.5	Copyright .....	E1/8
1.6	First Steps .....	E1/8
1.6.1	Unpacking and Inspection .....	E1/8
1.6.2	Installation .....	E1/8
1.6.3	Adjustments, Repair.....	E1/9
1.6.4	Accessories, Options.....	E1/9
1.6.5	Connector Field .....	E1/10
1.6.6	Connector Pin Assignments .....	E1/11
1.7	Technical Specifications .....	E1/13
1.7.1	Drive System .....	E1/13
1.7.2	Recording Formats.....	E1/13
1.7.3	Audio Processing.....	E1/13
1.7.4	Audio Input/ Output.....	E1/13
1.7.5	Synchronization .....	E1/14
1.7.6	Timecode .....	E1/14
1.7.7	Control Interfaces .....	E1/14
1.7.8	Power Supply.....	E1/15
1.7.9	Operating Conditions.....	E1/15
1.7.10	Standards .....	E1/15
1.7.11	Physical Dimensions.....	E1/15
1.8	Syntax Used in this Manual .....	E1/16
<b>2</b>	<b>Operating elements .....</b>	<b>E2/1</b>
2.1	General.....	E2/2
2.2	Transport Section.....	E2/2
2.3	Editing Section.....	E2/3
2.4	Keyboard and Register Section.....	E2/3
2.5	Display and Menu Section .....	E2/4
2.6	Additional Functions (Desktop Controller only).....	E2/4

<b>3</b>	<b>Getting Started Quickly .....</b>	<b>E3/1</b>
3.1	Recording New Takes From an Analog Source .....	E3/1
3.1.1	Installation and Settings .....	E3/1
3.1.2	Start Recording.....	E3/1
3.2	Recording New Takes From a Digital Source .....	E3/2
3.2.1	Installation and Settings .....	E3/2
3.2.2	Start Recording.....	E3/2
3.3	Playing Pre-Recorded Disks.....	E3/3
3.3.1	Installation and Settings .....	E3/3
3.3.2	Position .....	E3/3
3.3.3	PLAY and STOP.....	E3/3
3.3.4	Skip to Take and Index Markers .....	E3/3
3.3.5	CUE and SHUTTLE .....	E3/3
3.3.6	LOCATE.....	E3/4
3.3.7	Setting Markers .....	E3/4
3.4	Editing.....	E3/5
3.4.1	Before You Start Editing.....	E3/5
3.4.2	Cut Out or Erase an Element – Cut/ Erase Editing.....	E3/5
3.4.3	Move or Duplicate an Element – Insert Editing .....	E3/6
3.5	Insert Recording .....	E3/7
3.5.1	Before You Start Recording.....	E3/7
3.5.2	Manual Insert Recording .....	E3/7
3.5.3	Auto Insert Recording .....	E3/7
3.6	Working with Sequences.....	E3/8
3.6.1	Change the Current Sequence .....	E3/8
3.6.2	Create a New Sequence.....	E3/8
3.6.3	Modify a Sequence.....	E3/8
3.6.4	Copy a Sequence .....	E3/9
3.6.5	Delete a Sequence .....	E3/9
3.7	CD Transfer and Disk Copies.....	E3/10
3.7.1	Before you Start the Transfer .....	E3/10
3.7.2	Creating a CD with an External SCSI CD Writer (e.g. Studer D741).....	E3/10
3.7.3	Copying a CD to the D424.....	E3/11
3.7.4	Copying to/ from Other MO Disks.....	E3/11
3.8	Working with Timecode.....	E3/12
3.8.1	Recording Timecode .....	E3/12
3.8.2	Playing Back Timecode .....	E3/12
3.8.3	Chasing to Timecode.....	E3/12
3.9	The Desktop Controller.....	E3/13
3.9.1	Installation and Settings .....	E3/13
3.9.2	Operation Enhancements.....	E3/13
3.10	The Parallel Port with Fader Start Operation .....	E3/14
3.10.1	Signal List .....	E3/14
3.10.2	Fader Start.....	E3/14
3.11	The Setup Menu .....	E3/15

<b>4</b>	<b>Operation.....</b>	<b>E4/1</b>
4.1	System Configuration .....	E4/1
4.1.1	Recording Formats.....	E4/1
4.1.2	Audio Input.....	E4/2
4.1.3	Reference Clock Source.....	E4/2
4.1.4	Other Parameters .....	E4/3
4.2	Display and Register Functions .....	E4/4
4.2.1	Display Information and Formats .....	E4/4
4.2.2	Using General Purpose Registers.....	E4/6
4.3	Basic Transport Operation.....	E4/7
4.3.1	The Current Position.....	E4/7
4.3.2	Playback and Stop .....	E4/9
4.3.3	Skipping to Take and Index Markers.....	E4/9
4.3.4	The CUE and SHUTTLE Modes.....	E4/9
4.3.5	Locating to a Random Position.....	E4/10
4.4	Recording.....	E4/11
4.4.1	The D424 Recording Modes.....	E4/11
4.4.2	Channel Assignments.....	E4/12
4.4.3	Rehearse Mode .....	E4/12
4.4.4	Meters .....	E4/13
4.4.5	Adjusting the Analog Input Level.....	E4/13
4.4.6	Before You Start Recording... ..	E4/13
4.4.7	Assemble Recording .....	E4/14
4.4.8	Insert Recording .....	E4/14
4.4.9	Auto Insert Recording.....	E4/15
4.5	Editing .....	E4/16
4.5.1	Setting IN and OUT Points.....	E4/16
4.5.2	The CUT Function.....	E4/17
4.5.3	The ERASE Function .....	E4/18
4.5.4	The INSERT Function.....	E4/18
4.5.5	Combined Editing Processes .....	E4/19
4.5.6	The PREVIEW Function .....	E4/19
4.6	Sequence Editing .....	E4/21
4.6.1	Selecting a Sequence .....	E4/21
4.6.2	Creating a New Sequence .....	E4/21
4.6.3	Deleting a Sequence .....	E4/21
4.6.4	Editing a Sequence .....	E4/22
4.7	CD Transfer and Disk Copies.....	E4/24
4.7.1	Configuration.....	E4/24
4.7.2	Transfer to a CD Writer.....	E4/24
4.7.3	Copying a CD to the D424 .....	E4/26
4.7.4	Copying to/from Other Disks.....	E4/27
4.7.5	Transfer Parameters .....	E4/28
4.7.6	SCSI Addresses .....	E4/29
4.8	Backup Copies .....	E4/30
4.8.1	Sequence Backup.....	E4/30
4.8.2	Disk Backup .....	E4/31
4.9	Data Exchange with SADiE® Workstations.....	E4/32
4.9.1	DAW Configuration .....	E4/32
4.9.2	Importing D424 Disks to the DAW .....	E4/32
4.9.3	Importing SADiE® Disks to the D424 .....	E4/33



4.10	Setup Menu .....	E4/34
4.10.1	Accessing and Modifying Menu Items .....	E4/34
4.10.2	Overview .....	E4/35
4.10.3	Menu 1, CONFIG (System Configuration) .....	E4/36
4.10.4	Menu 2, REF & INP (Reference & Input Parameters) .....	E4/37
4.10.5	Menu 3, AUDIO (Audio Parameters) .....	E4/38
4.10.6	Menu 4, TRANSPORT (Transport & Display Parameters) .....	E4/39
4.10.7	Menu 5, DISK (Disk & Sequence Utilities) .....	E4/40
4.10.8	Menu 6, COPY (Copy Utilities) .....	E4/42
4.10.9	Menu 7, SERVICE (Service Utilities) .....	E4/44
4.11	Desktop Controller .....	E4/45
4.11.1	Configuration .....	E4/45
4.11.2	Operation .....	E4/45
4.12	Parallel Port and Fader Start Operation .....	E4/46
4.12.1	Specifications .....	E4/46
4.12.2	Signal Description .....	E4/46
4.12.3	Fader Start .....	E4/47
4.13	Serial Remote Operation .....	E4/48
4.13.1	Command List .....	E4/48
<b>5</b>	<b>Troubleshooting .....</b>	<b>E5/1</b>
5.1	Error Messages .....	E5/1
5.2	Modifying the D424 SCSI Address .....	E5/3
<b>6</b>	<b>D424 - Circuits, Jumper Setting .....</b>	<b>E6/1</b>
6.1	Motherboard .....	E6/1
6.1.1	Clock Regeneration .....	E6/1
6.1.2	Time Code .....	E6/2
6.1.3	Audio .....	E6/2
6.1.4	Desktop Controller .....	E6/3
6.1.5	Power Supply .....	E6/3
6.1.6	Jumper and DIP Switch Settings .....	E6/3
6.2	Core .....	E6/4
6.2.1	Jumper and DIP Switch Settings .....	E6/4
6.3	A/D-D/A Board .....	E6/5
6.3.1	Level Setting .....	E6/5
6.4	Keyboard .....	E6/5
6.5	Display Board .....	E6/5
6.6	Connector Pin Assignments .....	E6/6
<b>7</b>	<b>Desktop Controller - Circuits, Jumper Setting .....</b>	<b>E7/1</b>
7.1	Remote Keyboard .....	E7/1
7.2	Remote Control PCB .....	E7/1
7.3	Display PCB .....	E7/1

**8 Diagrams.....**

**9 Appendix..... E9/1**

- 9.1 Serial Remote Protocol ..... E9/1
  - 9.1.1 RS422 9-pin Protocol (Sony-Compatible)..... E9/1
  - 9.1.2 Communication Format ..... E9/1
  - 9.1.3 Hardware Layer ..... E9/2
  - 9.1.4 Messages..... E9/2
  - 9.1.5 Command List..... E9/4
  - 9.1.6 Command Messages ..... E9/5
- 9.2 Drive Installation Instructions..... E9/7
  - 9.2.1 MO Drive Kit 2.6 GB (ISO)..... E9/7
  - 9.2.2 MO Drive Kit 5.2 GB (ISO)..... E9/8
- 9.3 Hardware Configuration (Jumper and DIP Switch Settings) ..... E9/9
  - 9.3.1 Motherboard ..... E9/9
  - 9.3.2 Core ..... E9/9

# 1 GENERAL

---

## 1.1 MO Recording

---

For a long time, analog tape recording has been the standard recording technology in the professional audio industry. The step into the digital audio era has been done a few years ago with the introduction of digital tape recorders, such as DASH and R-DAT machines. Another important evolution was pushed by the computer industry: Hard disk-based workstations record on fast, direct-access media that are also capable for later editing without destroying the original information.

Beginning with the consumer format CD, a removable medium with excellent price and archiving characteristics, the optical disk became in the meantime a reliable recording media standard, in audio and computer industry.

Taking the advantages of the above approaches:

- Well accepted and easy-to-understand surface of a dedicated audio recorder,
- Versatile and future-proof technology, based on standard data storage devices (SCSI-2),
- Removable medium with very good archiving characteristics and the capability for direct access editing,

the Studer D424-2 MO recorder has been designed to be integrated into today's and future environments, combined with analog and digital audio processing and automation. It is ready to follow the rapid evolution of recording technology, without neglecting the needs of the professional user.

## 1.2 The Medium – Magneto-Optical Disks

---

### 1.2.1 Disk Standards

---

The D424 MO recorder with ISO drive is equipped with a 5.25" MO drive capable of reading and writing to the standard double-sided 5.25" disk types listed below. Only high-quality disks should be used for the D424 application. Please contact your Studer representative for information on the recommended suppliers.

1.2 GB (512 bytes/sector)	available on request
2.3 GB (512 bytes/sector)	available on request
1.3 GB (1024 bytes/sector)	available on request
2.6 GB (1024 bytes/sector)	Order No. 15.622.260.13
4.8 GB (1024 bytes/sector)	available on request
5.2 GB (2048 bytes/sector)	available on request

The D424 will automatically recognize the type of the disk being inserted. Direct-overwrite (LIM-DOW) type disks are only supported when the D424 is equipped with a F-541-DW drive.

### 1.2.2 Disk Formatting

---

New disks are preformatted from the manufacturer. This process is called "low-level formatting". It is only useful after having cleaned a disk that had numerous defective blocks. Low-level formatting will then re-check every bit on the disk for validity, which can take up to 40 minutes.

In order to start recording, the D424 only has to add the basic system files. Building up a DOS system and installing the basic D424 files is called "high-level formatting", or simply "formatting". This process takes only a few seconds.

After inserting a new, empty disk for the first time, the D424 will automatically ask for formatting. Any prerecorded disk may be re-formatted at any time. This is a fast and direct way to delete the whole contents of a disk.

### 1.2.3 Disk Capacities

Depending on disk type, sampling rate, and recording format, the recording capacity will vary. The following table shows some examples of the recording capacities (stereo, per side):

Disk type	44.1 kHz / 16 bit	48 kHz / 16 bit	48 kHz / 24 bit
1.2 GB ISO	55 min	50 min	34 min
1.3 GB ISO	60 min	55 min	37 min
2.3 GB ISO	1 h 45 min	1 h 37 min	1 h 5 min
2.6 GB ISO	2 h	1 h 50 min	1 h 15 min
4.8 / 5.2 GB ISO	3 h 15 min	3 h	2 h

**Notes:** All 5.25" disks are double-sided. Each side provides the stereo capacity listed above.

Because of the DOS operating system, a maximum of 2 GB can be used; 4.8 and 5.2 GB disks are automatically formatted with a maximum partition.

With 1.2 and 1.3 GB disks, the insert recording modes are limited to 16 and 20 bit resolution. For assemble recording and editing there is no such limitation.

## 1.2.4 Disk Handling

Disks can be write-protected by sliding the appropriate tab to the “data protect” position (see manufacturer's information).

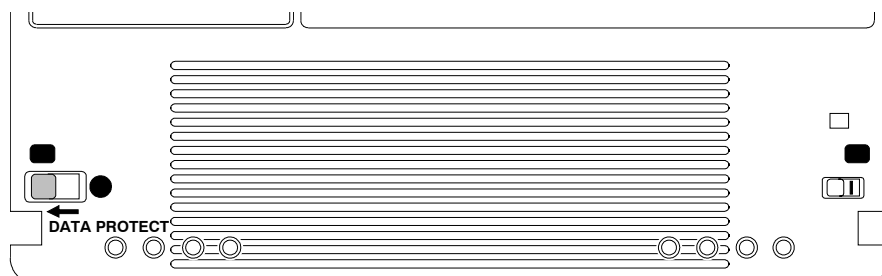

The magneto-optical medium is very reliable. Nevertheless, there are some recommendations for disk storage and handling:

- Always store a disk in its case.
- Keep the disk cartridges away from sources of heat, excessive dust, or moisture.

Please, follow also the information of the disk manufacturer.

After being exposed to a dusty environment, some blocks may be marked as defective during recording. The MO drive will automatically assign spare blocks for storing the affected audio information.

The D424 will check a disk when set to RECORD READY. A warning message will be displayed if more than 60 grown defective sectors were found.

When starting with a new production, empty disks should not report any defective blocks. It is therefore recommended to clean empty disks with appropriate tools when encountering such warning messages. After a subsequent low-level formatting process, the disk will again be in perfect shape for further recordings.

If the number of reported defective blocks is increasing notably, any further recording and editing should be avoided. Backup your data before resuming your session.

Please contact your disk supplier or Studer for detailed information on accessories as disk cleaning kits.

---

## 1.3 File Systems, File Formats, Audio Files

---

The D424 MO-recorder is based on a SCSI-controlled magneto-optical drive, and standard ISO disks as storage medium. The same drives and disks are used in computer applications for storing and archiving.

By using the same file system and formats as MS-DOS based computer platforms, disks that were recorded with a D424 can be played by all DOS based systems – from simple multimedia computers to fully professional audio workstations.

The D424 is storing all audio information to sound files in standard Microsoft Wave format (\*.WAV), including all relevant recording parameters, as sampling rate, word length, and number of channels.

All further information on the structure of a session as well as all editing information are kept in separate sequence files (\*.seq), also known under the name Edit Decision List (EDL).

---

### 1.3.1 Takes, Indices, and Sequences

---

When working with the D424, you don't have to care for sound files, directories, or disk structures and the like; the following definitions, however, are important for your recording, editing, and playback work.

The recorded material is subdivided into takes and indices.

- Every time you start recording, a new take is created.
- Place additional take markers during a long recording session. In a concert you may mark the begin of a new song. This will save time for creating the definitive markers when editing later.
- Store additional index markers at positions to be edited. Later, you will be able to address them directly, without the need for searching.
- During the subsequent editing session, all markers having been previously set can be deleted or moved. New ones can be set in order to prepare your project for transferring to a CD, with all desired take and index markers.

When you start working with a new project, all settings and editing information will be stored to the currently selected sequence. Only one sequence can be active at a time, this is called the “Current Sequence”.

- When you start recording on a new disk, a first sequence will be created. You will stay with this first sequence until you switch to a new one.
- Create a new, empty sequence for a different project. Start recording and do your editing session in a separate environment. It is very easy to switch between different sequences.
- You can have several sequences for a single project – do your basic editing first, copy the current sequence to a new one, and continue with your session. You will have access to the basic version at any time.
- Make different versions of an original recording. You can decide at the end of your projects, which one you would like to keep – or keep all of them. Sequences do not require much storage capacity.

**Takes, Indices:** Insert a new, empty disk, set the channels ready, and press REC+PLAY. The first take in the initial sequence 1 will be recorded. Each time you start recording, a new take is created, which is given a numbered take marker at its beginning automatically.

After having recorded three audio takes, the contents of the disk will look like this:

1	2	3
take 1	take 2	take 3

The current sequence now consists of three takes. Simply record one more take, and you will end up with:

1	2	3	4
take 1	take 2	take 3	take 4

Whenever there is a need for marking certain points within a take, or to subdivide a single take into smaller parts, you can create indices by freely placing index or take markers anywhere within your sequence, either on-line during recording, or later when editing.

Take 2 can be divided into two separate takes by placing an additional marker. The new take marker gets number 5, which is the next free number in the current sequence. In addition, a certain position in take 4 is marked with an index.

1	2	5	3	4.1	4.2
take 1	take 2	take 5	take 3	take 4	

After having placed these markers, you can not only skip from one original take to the next one, like with a CD player, but also skip to the new markers.

In the example above, the skip sequence is: 1 – 2 – 5 – 3 – 4.1 – 4.2

All the markers can simply be deleted if they are not required anymore. In case of deleting the take markers 3 and 5 in the above example, the takes 2, 5, and 3 would be joined to a new take. The result would be like this:

1	2	4.1	4.2
take 1	take 2	take 4	

Finally, markers can be moved, to adjust the take structure of the existing source material, e.g. to define the position of the tracks and indices of a CD, or to prepare precise start positions for on-air broadcasting.

After moving the begin of take 2, the above sequence will look like this:

1	2	4.1	4.2
take 1	take 2	take 4	



**Sequences:** If it is necessary to make another production with the same recorded material, a new sequence is defined. In the following example, only the takes 2, 3, and 4 should be edited, but in reverse order.

1	2	3	4
take 1	take 2	take 3	take 4

For this purpose, create a new sequence with the Sequence Editing feature, insert the required takes in their new order (takes 4, 3, and 2), and the new sequence will be:

4	3	2
take 4	take 3	take 2

You can now start with further editing, like changing markers, renumbering, cutting or re-arranging audio information, or adjusting levels.

With a few keystrokes you can switch to another available sequence on the disk, and start playing, recording, or editing.

**Note:** Creating new sequences does not need additional audio file capacity on a disk. There is only a new small EDL file, describing how to play the same audio data in a different way.

### 1.3.2 Non-Destructive Editing

The D424 is providing non-destructive editing. Because all editing processes are simply instructions on how to play the original sound files, the original audio data remain untouched during the whole editing process.

The following processes therefore only modify the sequence data, not the original audio data:

- Creating, deleting or moving markers.
- Deleting, erasing and inserting audio elements.
- Changing the order of takes.
- Adjusting output levels.

It is possible to have several sequences on the same disk representing different variations of the same basic audio material. Each sequence stores the editing data into its own sequence file, but will make use of the same audio files.

Without explicitly deleting sound files, which has to be done with a separate menu utility, the original data can be re-used at any time. It is hardly possible to delete audio data by accident.

## 1.4 Utilization for the Purpose Intended

---



The Studer D424 is a Disk recorder intended for professional use. It is designed for recording on MO disks.

*It is presumed that the unit is operated only by trained personnel. Servicing is reserved to skilled technicians.*

*The electrical connections may be connected only to the voltages and signals designed in this manual.*

## 1.5 Copyright

---



*Copies of pre-recorded Material:*

*Please consider that copying pre-recorded information is only allowed with the approval of the authorized copyright holders of the original material.*

## 1.6 First Steps

---

### 1.6.1 Unpacking and Inspection

---

Your new MO recorder is shipped in a special packing which protects the unit against mechanical shock during transit. Care should be exercised when unpacking so that its surfaces do not get marred.

Verify that the content of the packing agrees with the items listed on the enclosed shipping list.

Check the condition of the equipment for signs of shipping damage. If there should be any complaints you should immediately notify the forwarding agent and your nearest Studer distributor.

Please retain the original packing material because it offers the best protection in case your equipment ever needs to be transported.

### 1.6.2 Installation

---



**Power Connection:** The attached female IEC 320/C 13 mains cable socket has to be connected to an appropriate mains cable by a trained technician with respect to your local regulations. Refer to the “Installation, Operation, and Waste Disposal” section at the beginning of this manual.

*Maintenance work inside the unit must be performed by a trained technician.*

**Humidity:** Do not use the unit near any source of moisture or in excessively humid environments.

**Cooling:** To allow for reliable operation, the maximum temperature of the disk cartridge must never exceed 55° C (131° F), no matter in which operating mode. When installing the unit in a rack or any other location, be sure that there is sufficient ventilation. The maximum ambient temperature for operating the unit is 35° C.

A unit operated outside a rack must be placed on a rigid, flat surface. The air vents must never be covered completely or partially.

When operating the unit inside a rack, sufficient cross-sections must be provided above and below the unit for air convection. The air inlet below the unit must have a minimum cross-section of  $8 \times 420$  mm. Above the unit, a free area of minimum 43 mm (1U) with an air outlet of  $40 \times 420$  mm must be provided.

During operation, the temperature of the incoming air (from the front of and from below the unit) must never exceed  $35^{\circ}$  C.

### 1.6.3 Adjustments, Repair

---



**Danger:** *All internal adjustments as well as repair work on this product are to be performed by skilled technicians!  
During service work dangerous laser radiation can occur, so the appropriate precautions must be taken.*



**Primary Fuse:** The primary fuse (F 4 A H 250 V,  $5 \times 20$  mm) is located inside the unit. Therefore only skilled technicians are authorized to replace the fuse.

### 1.6.4 Accessories, Options

---

<b>Accessories Shipped with the D424:</b>	1 Operating manual (English)	Order No. 10.27.3803
	1 Female mains connector (IEC 320/C 13)	Order No. 54.42.1050
	1 MO Disk	
	1 Hexagon pin spanner 2.5 mm	Order No. 98.00.2023
	2 Fuses F 4 A, 250 V	Order No. 51.01.0156
<b>D424 Options:</b>	Desktop Controller	Order No. 20.866.500.00
<b>Recording Media:</b>	MO Disk 2.6 GB ISO (Other capacities available on request)	Order No. 15.622.260.13

### 1.6.5 Connector Field

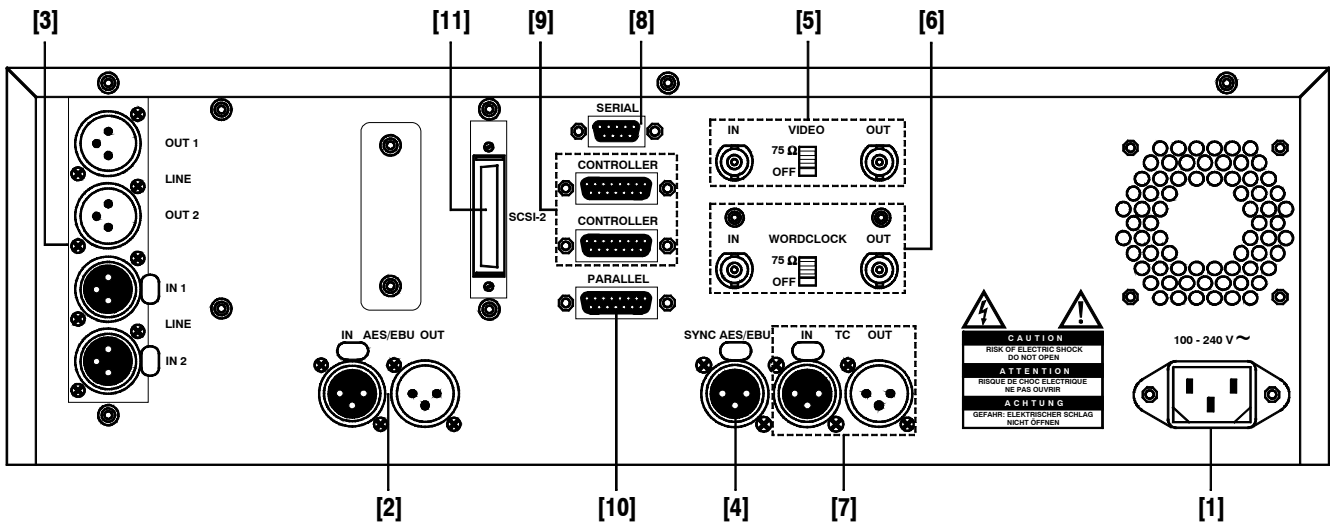

- |      |                                    |  |
|------|------------------------------------|--|
| [1]  | <b>AC PLUG</b>                     | AC power connector IEC 320/C 14 for mains supply 100...240 V, 50...60 Hz   |
| [2]  | <b>AES/EBU IN/OUT</b>              | AES/EBU digital audio I/O<br>Input (XLR-3, female) and output (XLR-3, male)  |
| [3]  | <b>ANALOG IN/OUT</b><br>(optional) | Analog audio I/O<br>Input CH1/CH2 (XLR-3 female) and output CH1/CH2 (XLR-3 male)   |
| [4]  | <b>SYNC AES/EBU</b>                | AES-11 digital audio reference<br>Input (XLR-3, female)  |
| [5]  | <b>VIDEO REFERENCE</b>             | Composite Video Reference, 75 $\Omega$ termination selectable<br>Input and output (loop through), BNC connectors         |
| [6]  | <b>WORD CLOCK</b>                  | Digital word clock, 75 $\Omega$ termination selectable<br>Input and output, BNC connectors                               |
| [7]  | <b>TIME CODE</b>                   | SMPTE/EBU longitudinal timecode<br>Input (XLR-3 female), and output (XLR-3 male)   |
| [8]  | <b>SERIAL</b>                      | Serial remote RS-422, Input<br>(SONY 9-pin compatible)   |
| [9]  | <b>CONTROLLER</b>                  | Desktop Controller, input and output (loop through)<br>For Desktop Controller operation and multi-machine configurations |
| [10] | <b>PARALLEL</b>                    | Parallel GPI port, input/output  |
| [11] | <b>SCSI-2</b>                      | SCSI-2 port<br>For external drive configurations and SCSI data transfer  |

**1.6.6 Connector Pin Assignments**

**INPUT/OUTPUT LEFT/RIGHT**

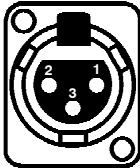
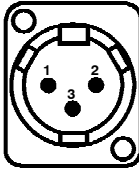
IN		OUT		Pin	Signal
				1	Ground
				2	Line A ("hot")
				3	Line B ("cold")
XLR-3f		XLR-3m			

**AES/EBU DIGITAL IN/OUT**

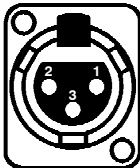
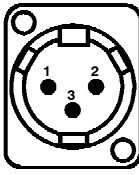
IN		OUT		Pin	Signal
				1	Ground
				2	Line A ("hot")
				3	Line B ("cold")
XLR-3f		XLR-3m			

**SERIAL 9 pin D-type, female**

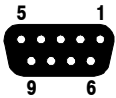
	Pin	Signal	Function
	1	FGND	Frame ground
	2	TXA	Transmit A (inverted)
	3	RXB	Receive B
	4	RXC	Receive common
	5	VCC	Supply voltage +24 V, switchable
	6	TXC	Transmit common
	7	TXB	Transmit B
	8	RXA	Receive A (inverted)
	9	FGND	Frame ground

**CONTROLLER 15 pin D-type, female**

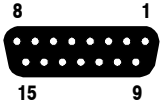
	Pin	Signal	Function
	1	PHL-	Phones left, inverted
	2	PHR-	Phones right, inverted
	3	AGND	Analog ground
	4	REMT	Rem bus transmit
	5	REMR	Rem bus receive
	6	STSTR	Start signal
	7	SYNCBUS	Sync bus
	8	DGND	Digital ground
	9	PHL+	Phones left
	10	PHR+	Phones right
	11	+24 V	Supply voltage
	12	IREMT	Rem bus transmit, inverted
	13	IREMR	Rem bus receive, inverted
	14	ISTSTR	Start signal, inverted
	15	ISYNCBUS	Sync bus, inverted

**PARALLEL 15 pin D-type, female**

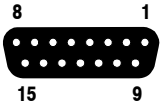
	Pin	Signal	Function
	1	B_TAKE	Take pulse
	2	B_INDEX	Index pulse
	3	B_PLAY	Play tally
	4	S_STOP	Stop command
	5	S_PLAY	Play command
	6	S_PLOC	Ploc command
	7	FADER1	Fader start input 1
	8	GND	Ground
	9	B_STOP	Stop tally
	10	B_READY	D424 ready
	11	VCC	Supply voltage, switchable 5/24 V
	12	S_PREV	Previous command
	13	S_NEXT	Next command
	14	FADER2	Fader start input 2
	15	KEY	Key

## 1.7 Technical Specifications (Subject to change as technological progress may warrant)

### 1.7.1 Drive System

The D424 is equipped with an ISO standard 2.6 or 5.2 GB drive supporting the following 5¼" disk standards:

2 × WO	1.2 / 1.3 GB	512/1024 bytes/sector
4 × WO/DW	2.3 / 2.6 GB	512/1024 bytes/sector
8 × WO	4.1 / 4.8 / 5.2 GB	512/1024/2048 bytes/sector

(WO = Write Once; DW = Direct Overwrite)

The D424 also supports SCSI CD writers.

### 1.7.2 Recording Formats

- Linear recording mode with 16, 20 or 24 bit resolution
- Standard file system and audio files (MS-DOS and WAVE)
- Session data supports major manufacturer standard

### 1.7.3 Audio Processing

Switchable Word Length	16/20/24 bits
Sampling Rates	44.056, 44.1, 47.952, 48 kHz
Varispeed Operation	±12.5%
Digital Scrub Range	0...±2 V <sub>nom</sub>
Real-time Output Gain Control	(-∞...12 dB)

### 1.7.4 Audio Input/Output

Digital I/O	AES-3, balanced, transformer coupled, XLR connector
Monitor Output	(headphone connector) <ul style="list-style-type: none"> <li>• Unbalanced, 6.3 mm Jack connector</li> <li>• 16 bit D/A converter</li> </ul>
Impedance	100 Ω
Level	Max. 7 V, with potentiometer volume control
Analog In	(measured with line level of +15 dBu for 0 dB <sub>FS</sub> ) <ul style="list-style-type: none"> <li>• Balanced, transformer coupled, XLR connector</li> <li>• 20 bit delta-sigma converter (64 times oversampling)</li> </ul>
Impedance	>10 kΩ
Level	10...24 dBu (for 0 dB <sub>FS</sub> ), electronically adjustable in steps of 0.5 dB
Frequency Response	20 Hz...20 kHz ±0.1 dB
THD + N	< -87 dB <sub>FS</sub> (20 Hz...20 kHz, 0 dB <sub>FS</sub> ) < -103 dB <sub>FS</sub> (1 kHz, -20 dB <sub>FS</sub> )
Channel Crosstalk	> 110 dB (1 kHz)

<b>Analog Out</b>	(measured with line level of +15 dBu for 0 dB <sub>FS</sub> )
	<ul style="list-style-type: none"> <li>• Electronically balanced, XLR connector</li> <li>• 20 bit delta-sigma converter (128 times oversampling)</li> </ul>
<b>Impedance</b>	< 30 Ω
<b>Level</b>	4 digitally selectable levels between 10...24 dBu (for 0 dB <sub>FS</sub> ), adjustable with trimmer potentiometer (default +10, 15, 20, 24 dBu)
<b>Frequency Response</b>	20 Hz...20 kHz ±0.1 dB
<b>THD + N</b>	< -90 dB <sub>FS</sub> (20 Hz...20 kHz, -1 dB <sub>FS</sub> ) < -98 dB <sub>FS</sub> (1 kHz, -20 dB <sub>FS</sub> )
<b>Channel Crosstalk</b>	> 110 dB (1 kHz)
<b>De-Emphasis</b>	50 ms/15 ms

### 1.7.5 Synchronization

---

<b>AES-11 Input</b>	XLR connector
<b>Word Clock Input</b>	BNC connector, with termination selector. Minimum level: 1 V <sub>pp</sub>
<b>Composite Video Input</b>	2 BNC connectors, with termination selector
<b>Word Clock Output</b>	BNC connector, TTL Level

### 1.7.6 Timecode

---

Accepts and generates all available formats:  
24, 25, 29.97D and 30, 29.97 and 30D  
(D = drop frame mode for NTSC compensation)

<b>Reader</b>	For timecode recording and chase mode, balanced, transformer coupled, XLR connector
<b>Input Level</b>	0.5...5 V
<b>Speed Range</b>	0.1...2 times nominal speed
<b>Generator</b>	For providing LTC of current position, balanced, transformer coupled, XLR connector
<b>Nom. Output Level</b>	2 V (peak to peak)

### 1.7.7 Control Interfaces

---

- Desktop Controller interface  
For multi-machine configurations, providing sample-accurate synchronization between up to three D424 units (RS422, 15 pin D-type)
- System remote interface  
With proprietary or SONY 9 pin protocol (RS422, 9 pin D-type)
- Parallel port  
With basic commands, fader start and tallies (15 pin D-Type)
- SCSI-2 for external drives and data transfer



**1.7.8 Power Supply**

---

Power Requirements 100...240 VAC  $\pm$ 10%, 50...60 Hz, 1.4...0.6 A

**1.7.9 Operating Conditions**

---

Ambient Temperature: +5...+35 °C  
Rel. Humidity: 10...80%, non-condensing  
Operating Position: horizontal  $\pm$ 10°

**1.7.10 Standards**

---

Safety Standard: Protection class 1, EN 60950; 1992 + A1/A2; 1993  
Class 1 laser product, EN 60825-1; 1994  
EMC Standard: EN 50081-1; 1992, EN 50082-1; 1992

**1.7.11 Physical Dimensions**

---

Size 438 × 142 × 392 mm (W × H × D); 19" rack-mount size, 3 HU  
Weight 9.5 kg

## 1.8 Syntax Used in this Manual

---

[COMMAND] Keyboard entries are indicated in **bold** printing and within [ ] brackets.

[PLAY] “PLAY” key.

[REC+PLAY] Double key combination: [REC] is pressed first and, as long as [REC] is pressed, [PLAY] is pressed additionally.

[1...9] One of the keys [1] to [9].

[ENT or PLAY] *Either* the [ENT] *or* the [PLAY] key.

[SETUP] [3] [1] [6] [0] [ENT] [▶] [6] [0] [ENT] [SETUP]  
Sequence of keys pressed one after the other.

## 2 OPERATING ELEMENTS

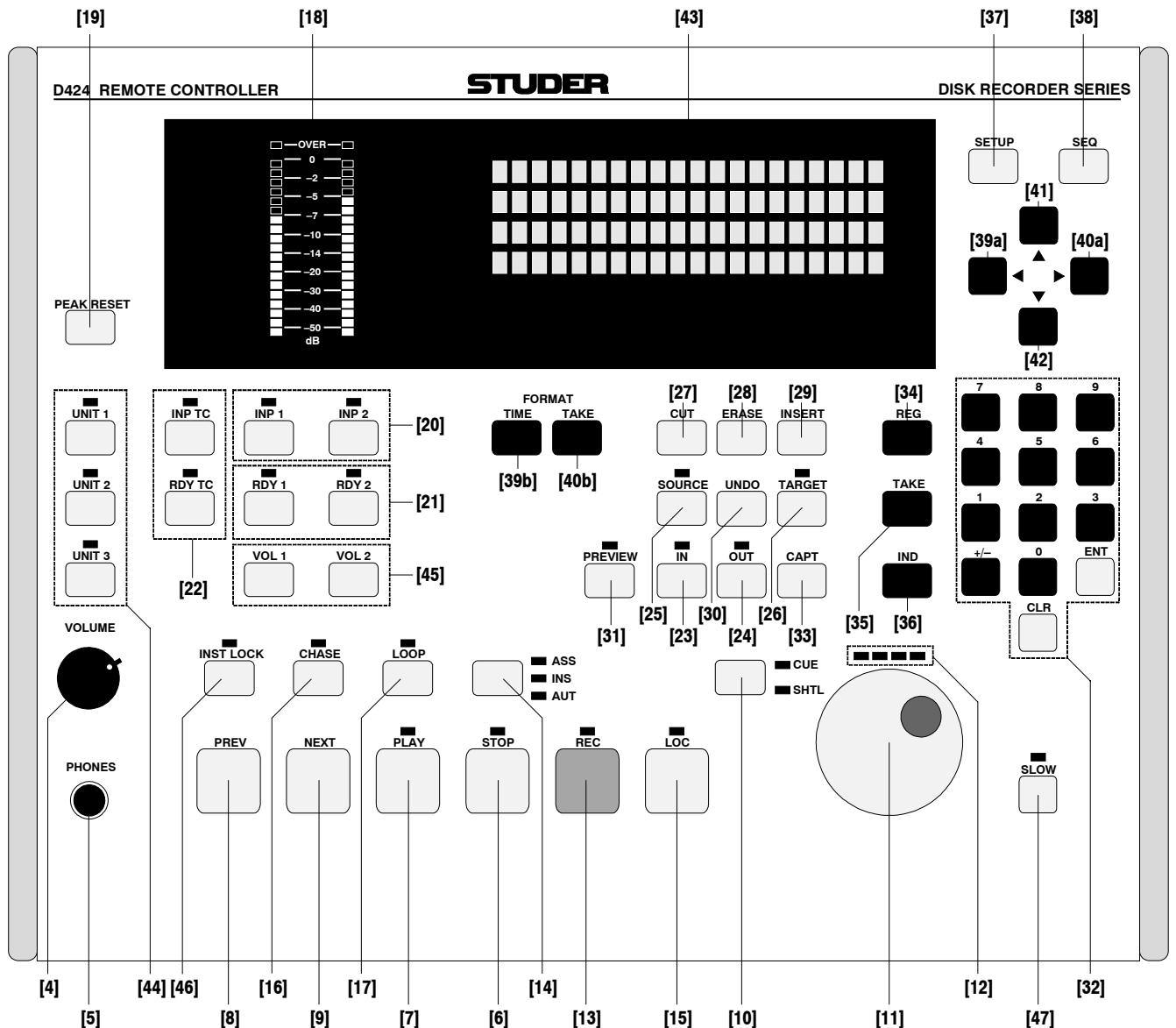
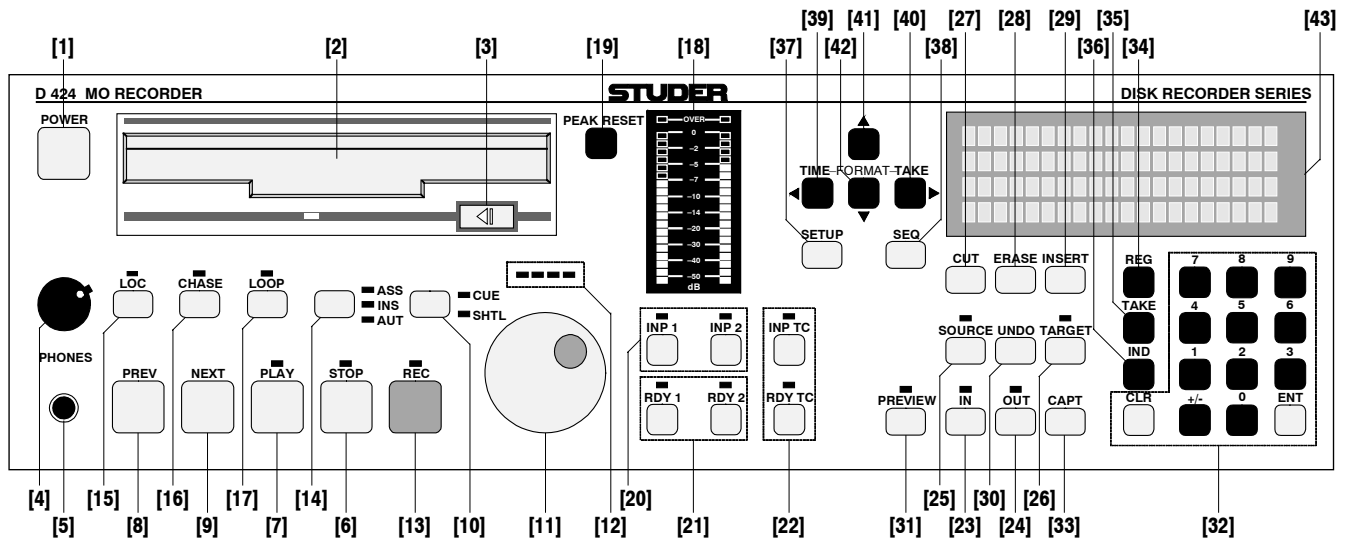

## 2.1 General (\* = not available on Desktop Controller)

---

*[1]	<b>POWER</b>	Switches the D424 on or off.
*[2]	<b>Disk</b>	A disk is inserted by gently pushing it in until the loading mechanism engages.
*[3]	<b>◀ (Eject)</b>	A disk is ejected by pressing this button in stop mode.
[4]	<b>VOLUME</b>	A stereo headphone may be connected to the 6.3 mm jack socket [5], the volume is adjusted with potentiometer [4].
[5]	<b>PHONES</b>	

## 2.2 Transport Section

---

[6]	<b>STOP</b>	Stops the recorder at the current position. During recording, a stop command terminates the session.
[7]	<b>PLAY</b>	Starts playing from the current position. During insert recording, a play command performs a punch-out.
[8]	<b>PREV</b>	Skips to the previous take or index marker.
[9]	<b>NEXT</b>	Skips to the next take or index marker.
[10]	<b>CUE/SHTL</b>	The control wheel key [10] switches to CUE or SHTL (shuttle mode), starting with the one that was used last. Each subsequent keystroke toggles between speed control (SHTL) and position control (CUE). The currently selected mode is indicated with the LEDs next to the CUE/SHTL key. The control wheel allows to modify speed or position, the current speed is indicated with the speed indication LEDs.
[11]	<b>Control Wheel</b>	
[12]	<b>Speed Indication LEDs</b>	
[13]	<b>REC</b>	Recording is started by pressing <b>[REC+PLAY]</b> simultaneously; a record-pause status is entered with the key combination <b>[REC+STOP]</b> .
[14]	<b>ASS/INS/AUT (Rec. Mode)</b>	One of the available recording modes (ASSEMBle/INSert/AUTo) is pre-selected by pressing the key [14] until the desired mode is indicated.
[15]	<b>LOC</b>	With this key and a subsequent destination (register, take/index number, or a shortcut) the D424 can be set to a new position.
[16]	<b>CHASE</b>	In chase mode, the D424 is following the external timecode.
[17]	<b>LOOP</b>	In loop mode the D424 plays the element between the IN and OUT point repeatedly.
[18]	<b>LED Level Meter</b>	Displays input or disk level, either in peak or in peak hold mode.
[19]	<b>PEAK RESET</b>	For resetting the meter display when in peak hold mode.
[20]	<b>INP 1, INP 2</b>	Output source selection. Either the input signal (LED is on) or the information from the disk (LED is off) is provided at the output channels.

- [21] **RDY 1, RDY 2** Record ready switch. The LED is flashing when the channel is set ready for recording; it is on during recording.
- [22] **RDY TC, INP TC** Timecode channel selectors.

## 2.3 Editing Section

---

- [23] **IN,**  
[24] **OUT** IN and OUT are the edit registers. A source element is defined with the IN and OUT registers, and the target point with the IN register (when in target mode).  
A register is selected with the corresponding keys **[IN]** or **[OUT]**, modifications are possible either with **[CAPT]**, the control wheel, or the numeric keypad.
- [25] **SOURCE** After selecting **[SOURCE]**, all edit operations related to a source element are enabled (cut, erase).
- [26] **TARGET** After selecting **[TARGET]**, the source element may be inserted at the target point with **[INSERT]**.
- [27] **CUT** Cuts out the source element.
- [28] **ERASE** Erases the contents of the source element.
- [29] **INSERT** Inserts the source element at the position defined with the target IN point.
- [30] **UNDO** The D424 reverts to the status before the last editing process.
- [31] **PREVIEW** In editing modes (source or target LED on), **[PREVIEW]** followed by a second key allows to preview either the edit points (with **[IN]** or **[OUT]**), the selected element (with **[SOURCE]**), or an edit process (with **[CUT]**, **[ERASE]**, or **[INSERT]**).  
When not in edit mode, the **[PREVIEW]** key is used as rehearse mode selector and indication for insert recording.

## 2.4 Keyboard and Register Section

---

- [32] **0...9, CLR, +/-, ENT** Register and menu parameters can be set with the numeric keypad. Values that were entered in the display buffer are stored to the register with the **[ENT]** key. With **[CLR]** the display buffer is cleared.
- [33] **CAPT** Copies the current position to the register selected with the numeric keypad.
- [34] **REG** With this key and a subsequent register number (0...9), one of the available registers is selected. It can be set and used for locating or editing.
- [35] **TAKE** This key is used for directly addressing takes for locating, or for setting and clearing take markers (in combination with **[INSERT]** and **[ERASE]**).

- [36] **IND** This key is used for directly addressing index positions within takes when locating, or for setting and clearing index markers (in combination with [INSERT] and [ERASE]).

## 2.5 Display and Menu Section

---

- [37] **SETUP** Pressing [SETUP] toggles between standard and SETUP mode, which is a menu-structured display mode for setting the D424's configuration and parameters, and performing system utilities. Submenus and items are selected with the cursor keys [39]...[42], the control wheel with [ENT], or directly with the numeric keys [1]...[8].
- [38] **SEQ** With [SEQ] the sequence editing mode is entered. It allows defining and editing sequences and deleting sound files (also refer to the Sequence editing section).
- [39] **TIME FORMAT / ◀** In standard mode, the current position may be switched between absolute, relative, or timecode formats.  
In setup and sequence editing modes the key is used as cursor key.  
**Note:** On the Desktop Controller, these two functions have dedicated keys.
- [40] **TAKE FORMAT / ▶** In standard mode, the current take number can be shown with or without index markers. If index markers are indicated as well, all skip functions are referring to both markers instead of take markers only.  
In setup and sequence editing modes the key is used as cursor key.  
**Note:** On the Desktop Controller, these two functions have dedicated keys.
- [41] **▲, [42] ▼** Cursor keys, used in setup and sequence editing modes.
- [43] **Display** The display section consists of 4 lines with 20 digits each. Depending on the selected mode, there are different configurations. The standard configuration is:  
**Line 1:** Graphical indication of the current position within the sequence  
**Line 2:** Current take (and index) number, current position  
**Line 3:** Sequence number, remaining time, or register entry field  
**Line 4:** D424 configuration (sampling frequency, word length, input, clock source, recording mode, emphasis).

## 2.6 Additional Functions (Desktop Controller only)

---

- [44] **UNIT 1...3** For assigning one of up to three D424 units to the Desktop Controller.
- [45] **VOL1, VOL2** For modifying the analog input attenuation for the two channels together with the control wheel.
- [46] **INST LOCK** Locks the unit immediately to a master timecode at the current position; the current offset is stored to the nominal offset register. Chase mode is selected automatically.
- [47] **SLOW** Reduces the cue speed to one third of the standard cue speed.

---

## 3 GETTING STARTED QUICKLY

---

### 3.1 Recording New Takes From an Analog Source

---

#### 3.1.1 Installation and Settings

---

1. Connect the analog outputs of the source unit to the analog input connectors of the D424 (LINE IN 1/2) with XLR cables.
2. Insert a write-enabled disk with sufficient free recording space (see step 7).
3. Check the status of the D424 in the fourth display line. There, sampling rate, recording format, clock reference, audio input, and recording mode are indicated.

The standard setting is: 441, 16, INT, ANA, ST.

If necessary, change the settings for sampling rate, recording format, and recording mode. The clock reference may also be external.

**Note:** There is only one sampling rate allowed per disk side. Changing the frequency is only possible with an empty disk.

4. Recording mode should be set to ASS (LED above the REC button), which is the default setting after switching on the D424.
5. Check the input levels by switching the D424 to input with [INP1] and [INP2].

Apply the input signals and check that there is no overload (red LED) at the loudest position. The input signal attenuation may be adjusted in the setup menu 31.

**Example:** Set the input attenuation of both channels to -6 dB:  
[SETUP] [3] [1] [6] [0] [ENT] [▶] [6] [0] [ENT] [SETUP]

#### 3.1.2 Start Recording

---

6. Set the recording channels to READY by pressing [RDY1] and [RDY2] (both corresponding LEDs will be on).
7. Check the remaining recording time with [REC+STOP]. The remaining time is indicated in the display.
8. Start recording with [REC+PLAY].
9. It is possible to set the take and the index markers on-the-fly with [TAKE+INSERT] or [IND+INSERT].
10. Stop the recording session with [STOP].

## 3.2 Recording New Takes From a Digital Source

---

### 3.2.1 Installation and Settings

---

1. Connect the AES/EBU output of the source unit to the AES/EBU input connector of the D424 (AES/EBU IN) with an XLR cable.
2. Insert a write-enabled disk with sufficient free recording space (see step 6).
3. Check the status of the D424 in the forth line of the display. It indicates sampling rate, recording format, clock reference, audio input and recording mode.

The standard setting is: 441, 16, INT, ANA, ST.

If necessary, change the settings for sampling rate, recording format, and recording mode.

Switch the input to AES/EBU with:

[SETUP] [2] [1],

select “dig” with: [▶] [ENT] [▲] [▶] [▼],

select “audio” with: [▶] [ENT] [SETUP].

**Notes:** There is only one sampling rate allowed per disk side. Changing the frequency is only possible with an empty disk.

An error message will appear when the D424 settings do not match with the source signals.

4. The recording mode should be set to ASS (LED above the REC button), which is the default setting after switching on the D424.

### 3.2.2 Start Recording

---

5. Set the recording channels to READY by pressing [RDY1] and [RDY2] (both corresponding LEDs will be on).
6. It is now possible to check the remaining time with [REC+STOP]. The remaining recording time is indicated in the display.
7. Start recording with [REC+PLAY].
8. It is possible to set the take and the index markers on-the-fly with [TAKE+INSERT] or [IND+INSERT].
9. Stop the recording session with [STOP].



### 3.3 Playing Pre-Recorded Disks

---

#### 3.3.1 Installation and Settings

---

- Check that the D424 is either set to internal reference, or the corresponding external reference clock has to be provided. With an external clock, the DIG indication in the bottom line of the display must not flash: 441, 16, INT, DIG, ST.
- Be sure that the INP switches are not activated.
- Insert a disk and wait until the sequence data have been loaded from disk.

#### 3.3.2 Position

---

Take and index numbers as well as the current position are shown in the display. The position indication may be adapted with the following keys:

[TIME] switches between absolute time (a: sequence time, starting with 0), relative time (r: take time, time within take) or timecode position (t). If no timecode was recorded, the timecode display is identical with the absolute time indication, the “t” mark is flashing.

[TAKE] switches between take display, or take *and* index display.

#### 3.3.3 PLAY and STOP

---

Start playing with [PLAY], stop at the current position with [STOP].

#### 3.3.4 Skip to Take and Index Markers

---

With [PREV] and [NEXT], the D424 will locate or continue playing at the next or previous marker. Depending on the selected TAKE mode, only take markers or take and index markers are considered.

**Example:** When playing take 5 and pressing [NEXT] twice, the D424 will continue playing at the beginning of take 7.

Use the LOCATE function to access markers directly.

#### 3.3.5 CUE and SHUTTLE

---

With [CUE], either the CUE or SHUTTLE mode is selected. Subsequent keystrokes toggle between the two modes.

In CUE mode, the D424 follows the control wheel position with a speed up to 2 times nominal speed. In SHUTTLE mode, the D424 moves with a constant speed set with the control wheel.

### 3.3.6 LOCATE

---

Find a particular position in a sequence with the locate function. Locating is available to sequence, take, and index positions as well as to register locations having been set in advance.

**Examples:**

[LOC] [PREV] – locate to begin of sequence  
[LOC] [NEXT] – locate to end of sequence  
[LOC] [2] [STOP] – stop at take 2  
[LOC] [2] [PLAY] – play from take 2  
[LOC] [2] [ENT] – locate to take 2  
[LOC] [2] [IND] [3] [PLAY] – play from take 2 index 3  
[LOC] [IN] – locate to IN register  
[LOC] [REG] [3] – locate to register 3.

When not terminated with [STOP] or [PLAY], the recorder will continue in the same status as it was before (stop or play).

### 3.3.7 Setting Markers

---

Set and remove markers with the following keystrokes:

[TAKE+INSERT] – inserts a new take marker  
[INDEX+INSERT] – inserts a new index marker  
[TAKE+ERASE] – removes the take marker that is currently displayed  
[INDEX+ERASE] – removes the index marker that is currently displayed.  
Moving a marker is achieved by removing it at the old position and inserting it at the new place.

**Notes:** Newly inserted take markers will get the first available free number, and will keep it during further editing.  
When moving a take marker with [ERASE] followed by [INSERT], it will keep its number.  
Index numbers are always contiguous within a take. After inserting or removing index markers, they will be renumbered automatically.

## 3.4 Editing

### 3.4.1 Before You Start Editing

- Verify that there is a write-enabled disk inserted.
- The sequence currently selected will be modified. If you have already edited a part of the sequence and you would like to keep the current version, start editing with a copy of the sequence.
- The current setting of the cross-fade time (setup menu item 34) will be used by all editing processes. Change them if necessary.

### 3.4.2 Cut Out or Erase an Element – Cut/Erase Editing

For cutting out or erasing an element of the current sequence:

- Define a source element by setting the edit registers **[IN]** and **[OUT]**, and perform an **[INSERT]** command.

With larger productions, it is helpful to mark the points to be edited in advance. For this purpose, set index markers either during the recording or when pre-listening the material.

1. Switch on the source editing mode with **[SOURCE]**.
2. Find the element to be removed and copy the start point of the element to the IN register, the end point to the OUT register. There are different ways:
  - Listen to the sequence and mark begin and end of the element with **[IN] [CAPT] [OUT] [CAPT]**, *or*
  - locate to the points when there are already markers and change to CUE for precise positioning. Transfer the current address to the register with **[IN] [CAPT]**, *or* **[OUT] [CAPT]**, *or*
  - search the point with the control wheel in SHTL mode (adjust the maximum wind speed in the setup menu 41, if necessary), slow down and change to CUE for precise positioning. Transfer the current address to the register with **[IN] [CAPT]** *or* **[OUT] [CAPT]**.
3. Check the settings with the REHEARSE feature. De-select the edit registers and choose one of the following rehearse commands:
  - [PREVIEW] [IN]** – listen to the section before the IN point
  - [PREVIEW] [OUT]** – listen to the section after the OUT point
  - [PREVIEW] [SOURCE]** – listen to the selected element between IN and OUT
  - [PREVIEW] [CUT]** – rehearse the cut command
  - [PREVIEW] [ERASE]** – rehearse the erase command.
4. Modify the edit points if necessary and check again (item 3). You can either locate to the edit point and adjust it:
  - [LOC] [IN] [CUE]...[IN] [CAPT]**, *or*
  - Trim the edit register directly with the cursor keys: **[IN] [▼] [▲]**.
  - Use the **[SOURCE]** and **[TARGET]** keys for accessing either the source registers IN and OUT, or the target register IN.
5. If the settings are correct, the final cut or erase command is **[CUT]** *or* **[ERASE]**.

If the result of the command is not what you expected it to be, or if a wrong edit command was executed by accident, it can be made undone with **[UNDO]**.

### 3.4.3 Move or Duplicate an Element – Insert Editing

For moving or duplicating an element of the current sequence:

- define a source element to be moved or duplicated, by setting the edit registers SOURCE IN and OUT,
- set the target location (i.e., where the source element should be inserted) by setting the edit register TARGET IN,
- and perform an INSERT command.

With larger productions, it is helpful to mark the points to be edited in advance. For this purpose, set index markers either during the recording or when pre-listening the material.

1. Activate the source editing mode with **[SOURCE]**.
2. Find the element to be removed, copy the start point of the element to the source IN register, and the end point to the source OUT register. There are different ways:
  - Listen to the sequence and mark begin and end of the element with **[IN] [CAPT] [OUT] [CAPT]**, *or*
  - locate to the points if there are already markers, and change to CUE for precise positioning. Transfer the current address to the register with **[IN] [CAPT]** or **[OUT] [CAPT]**, *or*
  - search the point with SHUTTLE (adjust the maximum wind speed in the setup menu 41, if necessary), slow down, and change to CUE for precise positioning. Transfer the current address to the register with **[IN] [CAPT]** or **[OUT] [CAPT]**.
3. Activate the target editing mode with **[TARGET]**.
4. Find the location to insert the source element defined above. Use one of the methods described in item 2, and copy the position to the TARGET IN point with **[IN] [CAPT]**.
5. Check the settings with the REHEARSE feature. De-select the edit registers and choose one of the following rehearse commands:
  - [PREVIEW] [IN]** – listen to the section before the insert point,
  - [PREVIEW] [OUT]** – listen to the section after the insert point,
  - [PREVIEW] [INSERT]** – rehearse the insert command.

For adjusting the source element, simply switch to source editing mode with **[SOURCE]** and use the corresponding preview commands (**[IN] [OUT] [SOURCE]**).
6. Modify the edit points if necessary and check again (item 3).  
You can either locate to the edit point and adjust it:  
**[LOC] [IN] [CUE]...[IN] [CAPT]**,  
*or*  
trim the edit register directly with the cursor keys: **[IN] [▼] [▲]**.  
Use the **[SOURCE]** and **[TARGET]** keys for accessing either the source registers IN and OUT, or the target register IN.
7. If the settings are correct, the final insert command is **[INSERT]**.

Repeat from step 3 if you like to insert the source element to different locations.

Moving an element is achieved by copying it to the destination first and then cutting out the original source element. Simply press **[CUT]** after the last **[INSERT]** command.

If the result of the command is not what you expected it to be, or if a wrong edit command was executed by accident, the *last command* can be made undone with **[UNDO]** (single level undo).

## 3.5 Insert Recording

---

Use insert recording for directly replacing a part of the current sequence in a “destructive way”. A typical example is dialog replacement.

### 3.5.1 Before You Start Recording

---

- Check your system configuration (refer to the analog or digital recording sections).
- With a correct setup, no LEDs should be flashing. After switching to input with the INP keys, you can monitor your source signal.
- You can check the free space available for recording with [RDY] [REC+STOP]. Press [STOP] again to revert to standby.

### 3.5.2 Manual Insert Recording

---

1. Select the INSERT recording mode with the recording mode key (above the STOP key). The “INS” LED will be on.
2. Set the recording channels to READY by pressing [RDY1] [RDY2] (the corresponding LEDs will be on).
3. Start playing ahead of the section to be replaced, wait until the correct position is reached, and then make record punch-in with a [REC+PLAY] command, *or* park the D424 at the punch-in location and start recording with [REC+PLAY].
4. Perform a punch-out with [PLAY] or [STOP].

**Note:** After having tried replacing a section for several times, all these attempts will be stored on the disk. They can be made accessible when creating a new sequence from the complete table of contents.

### 3.5.3 Auto Insert Recording

---

1. Select the AUTO recording mode with the recording mode key (above the STOP key). The “AUT” LED will be on.
2. Store the beginning and the end of the section to be replaced to the edit registers; IN: punch-in point, OUT: punch-out point.
3. Set the recording channels to READY by pressing [RDY1] and [RDY2] (the corresponding LEDs will be on).
4. Use the [PREVIEW] key to either perform a rehearsal (PREVIEW LED is on) or a recording (PREVIEW LED is off).
5. Start with [REC+PLAY].  
The D424 will start at IN-PREROLL, automatically perform a punch-in at the IN point and a punch-out at the OUT point. It will stop at OUT+POSTROLL.  
During the process, the current mode as well as a countdown to the following event are indicated.

## 3.6 Working with Sequences

---

There may be several sequences on a disk. Only one of them can be selected as the current sequence.

All modifications resulting from editing or sequence processing only change the sequence data that are kept with each sequence. They do not modify or delete the audio information.

The **[SEQ]** key gives access to a number of features, which allow to:

- switch between the available sequences on a disk,
- create new, empty sequences,
- modify sequences by inserting or deleting single takes,
- delete complete sequences, or
- copy existing sequences.

### 3.6.1 Change the Current Sequence

---

If there is a sequence no. 2 available on the disk, it is selected with **[SEQ] [2] [ENT]**.

### 3.6.2 Create a New Sequence

---

A new, empty sequence is created with **[SEQ] [ENT]**.

If it is necessary to assign a specific number to the new sequence, the new number is added to the command. If there are 3 sequences on a disk, and the following numbers should be reserved for additional revisions, a new sequence no. 10 is created with **[SEQ] [10] [ENT]**.

### 3.6.3 Modify a Sequence

---

#### Entering sequence editing mode:

When modifying a sequence, single takes can be added or deleted.

For entering the sequence editing mode, the following parameters are necessary:

- a source sequence number (i.e. the number of the sequence where the takes are to be copied from).
- a target sequence number (i.e. the sequence to be modified), and  
**[SEQ] [n] [SOURCE]** – modify sequence “n”; the default source sequence is the table of contents of the disk.  
**[SEQ] [n] [▶] [s] [SOURCE]** – modify sequence “n”, with source sequence “s”.

In editing mode, both source and target sequences are displayed. After having selected one of them with the **[SOURCE]** or the **[TARGET]** key, the take positions can be entered for executing the functions “add additional takes”, and “delete takes” described below.

**Adding additional takes:** Select the take to be copied from the source sequence, and the insert position in the target sequence:

[3] [TARGET] [5] [INSERT] – Insert take 3 from the source sequence, after take 5;

[INSERT] [INSERT], ... – further INSERT commands will copy takes 4, 5, and so on.

**Deleting takes:** Specify the target take to be deleted:

[TARGET] [4] [CUT] – delete take 4 from the target sequence;

[CUT] [CUT], ... – further CUT commands will delete take 3, 2, and so on.

### 3.6.4 Copy a Sequence

---

For copying an existing sequence, enter editing mode and perform a TARGET+INSERT command:

[SEQ] [▶] [2] [SOURCE] [TARGET+INSERT] – create a new sequence as a copy of sequence 2.

**Note:** If the [TARGET+INSERT] command is applied to a non-empty sequence, the current data are overwritten by the copied sequence data.

### 3.6.5 Delete a Sequence

---

For deleting a sequence, enter the editing mode and perform a [TARGET+CUT] command:

[SEQ] [2] [SOURCE] [TARGET+CUT] – delete sequence 2.

## 3.7 CD Transfer and Disk Copies

For making transfers and backup copies between the D424 and external drives such as further MO disk drives or CD writers, establish a SCSI connection between the two devices.

### 3.7.1 Before You Start the Transfer

- Switch the two units *off* and connect the SCSI cable.
- Make sure that the two units have not the same SCSI address. The default address of a D424 is “1”, the one of the Studer D741 is “2”. Refer to the corresponding section in the operating manual of the device for changing SCSI addresses.
- Switch on the peripheral device first, and switch it to SCSI mode (Studer D741: SCSI ON, D424: SCSI offline mode).
- Switch on the D424.

### 3.7.2 Creating a CD with an External SCSI CD Writer (e.g. Studer D741)

When making a master copy of the current D424 sequence to an external CD writer, the audio information including all track and index markers will be transferred to the CD. Furthermore, PQ information like ISRC and UPC codes can be added.

- Note:** Only sequences recorded with 44.1 kHz sampling rate can be directly transferred to the CD recorder.
- Insert a CD-R. Use an empty disc if you intend to burn a CD in a disc-at-once operation.

**Entering UPC and ISRC Codes** Select the UPC menu 642, enter the UPC code, and confirm with [ENT]. An UPC code will be accepted only if no UPC code has been programmed yet.

Select the ISRC menu 643 and enter a code for each track. Set the sequence to the first track and enter the code for track 1. For skipping the track number, use the [NEXT] key, and update the display with [▲] [▼].

- Note:** The first group of the ISRC code requires alphanumeric entries. Start with the [▼] key, select the digit with the control wheel and go on to the next digit with the [▶] key.

**Set the CD Transfer Parameters** Use the standard setting for transferring a 16 bit sequence to a new, empty CD. No additional processing is done (no noise shaping, no additional pauses will be inserted). Refer to “Operation”, section 4, for details.

**Start the Transfer** Select the master copy menu 62. If the “CD mounted” message is not visible, the CD writer has to be selected as target drive first:

- Select the “target” submenu and select the CD drive as target drive (use the [◀] or [▶] keys to locate one of the items, the [▼] key to select items or to enter submenus, or the [▲] key to return to the previous menu).
- Start the transfer process by moving to the “start” item and confirming with [ENT].

During the whole process, a progress bar is revealed. After a successful transfer, the disc will be finalized. Usually, the CD writer (e.g. Studer D741) will open its disc tray.



### 3.7.3 Copying a CD to the D424

The contents of a CD can be copied to a new sequence on the D424 disk, including all track and index markers.

- Check the inserted disk: it should not be write protected, have sufficient free capacity for adding the CD information, and the format must be CD compatible (44.1 kHz sampling rate).
- Select the CD writer as the current source drive. Use the setup menu 51 for this purpose; the CD drive usually has the SCSI address 2.
- If the copy mode in menu 644 is set to “toc”, the complete CD will be transferred; if it is set to “add”, only the currently selected track will be copied.

Use the D424 transport keys for pre-listening and selecting CD tracks.

- Select the master copy menu 62 and enter the “target” submenu to select the MO disk as target drive, the internal SCSI address is usually 1 (use the [◀] or [▶] keys to locate one of the items, the [▼] key to select items or to enter submenus, or the [▲] key to return to the previous menu).
- Start the transfer process by moving to the “start” item and confirming with [ENT].

During the whole process, a progress bar is revealed. After a successful transfer, the display reverts to standard mode.

### 3.7.4 Copying to/from Other MO Disks

Sequences and complete disks can be copied from the internal drive to additional external drives. There are 3 possible choices:

<b>DISK COPY</b>	will copy the complete disk. The target disk has to be empty. Reformat it before, if necessary (setup utility 53).
<b>MASTER COPY</b>	will create a new sequence on the target disk as an exact copy of the source sequence, including track and index information. The audio information will be merged into a new single sound file.
<b>WORK COPY</b>	will create a new sequence on the target disk. It is identical with the source, and includes all sequence information. All sound files used by the sequence will be transferred as well.

- Check the target disk. It must not be write protected, have enough free capacity for adding the source information, and the sampling rate of both disks must be identical.
- Use the setup menu 51 to check if:  
the internal drive is currently selected as the active one, and  
the external drive appears on the drive list.
- Go to one of the copy menus (Work Copy 61, Master Copy 62, Disk Copy 63) and check the indicated transfer information “copying sequence/track i to drive m”)
- Modify the target address if necessary (submenu target).
- Start the transfer process by moving to the “start” item and confirming with [ENT].

During the whole process, a progress bar is revealed. After a successful transfer, the display reverts to standard mode.

## 3.8 Working with Timecode

---

The D424 provides an LTC timecode input that allows to record LTC timecode. When playing back a sequence consisting of takes with different timecode positions, the D424 will provide a contiguous timecode defined by the first take.

### 3.8.1 Recording Timecode

---

- Check for correct timecode wiring by selecting [**INP TC**]. The incoming code should be displayed.
- When recording timecode, be sure that the timecode source and the D424 are running synchronously. The usual way is to provide a common video reference signal.
- Enable timecode recording with [**TC RDY**]. When the corresponding LED is on, the timecode position will be added to the audio information of all subsequent recording sessions.

**Notes:** The timecode information will be recorded as a single TC stamp at the beginning of an audio file. Timecode jumps during recording will not be considered.

*Timecode can be recorded only together with audio channel(s) set to ready.*

### 3.8.2 Playing Back Timecode

---

The D424 always provides the current position at the TC output connector. If no timecode was recorded, the absolute position is present. During STOP or CUE, a stationary code is generated.

### 3.8.3 Chasing to Timecode

---

In chase mode, the recorder is following an external timecode.

- When chasing to a master timecode, make sure that the master and the D424 are running with the same reference clock. Both master and D424 must be configured to the same timecode format.
  - Start/stop the chase mode with [**CHASE**].
- Chase LED is On:** Chase mode is on, D424 runs synchronously in PLAY mode.  
**Chase LED is Flashing:** Chase mode is on, but D424 waits because the master is not in PLAY mode (STOP or fast forward/rewind).
- An offset can be applied by storing a value ( $\pm 12$  hours) into the nominal offset register. It is accessed with [**REG**] [**0**].
  - An “instant lock” command will lock the D424 at the current position by storing the current offset to the nominal offset register and launching the chase mode. The command is performed with [**LOC+CHASE**] or with the [**INST LOCK**] key of the desktop controller.

## 3.9 The Desktop Controller

The Desktop Controller may be used to control up to 3 recorders with an ergonomic user interface.

### 3.9.1 Installation and Settings

1. Use the controller cable to connect the desktop controller to one of the two controller ports at the rear side of the D424. Connect further units with separate sync cables. The second connector of the last recorder must be terminated (termination plug).

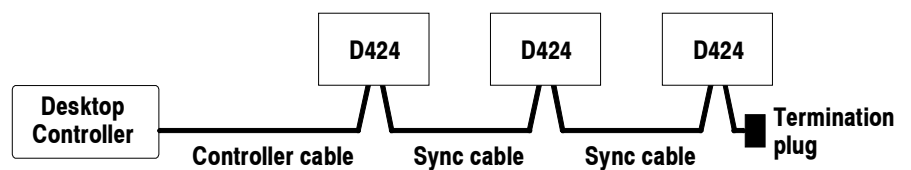

2. Check the addresses of the connected units in setup menu 15. *Each D424 should have a unique address.*

### 3.9.2 Operation Enhancements

Desktop controller operation of a D424 is the same as front panel operation, except for the following enhancements:

1. The controller is activated by selecting one of the connected units, using the keys [UNIT1], [UNIT2], or [UNIT 3]. The D424 will indicate remote operation by a message in its local display. Press an other [UNIT ...] key (or the active one again) for de-selecting the recorder being active.
2. Setting the input attenuation of the analog input signal is easier. Instead of selecting the menu item 31, simply hold down the [VOL1] or [VOL2] key and modify the level with the control wheel.
3. There are two different resolutions for the CUE mode. With the [SLOW] key, the CUE speed is one third of the standard speed for more precise locating.
4. The mode keys for switching the take/index format and the time format are now separated ([◀] and [▶] at the front panel).
5. The [LOC] key is closer to the destination keys ([IN] [OUT] [0...9]) and it has the same size as the other main transport keys.
6. To the left of the [CHASE] key, there is a separate key for the [INSTANT LOCK] function.

## 3.10 The Parallel Port with Fader Start Operation

A parallel remote port is provided for basic transport control and status indication, a fader start circuit, and supply voltages for external circuits.

### 3.10.1 Signal List

Inputs		
4	S_STOP	Generates a Stop command
5	S_PLAY	Generates a Play command
6	S_PLOC	Generates a Locate command to the last Play position (PlayLoc)
12	S_PREV	Generates a Previous command, skip to the previous take/index
13	S_NEXT	Generates a Next command, skip to the next take/index
7	FADER1	Fader start contacts
14	FADER2	
Outputs		
1	B_TAKE	Take pulse, when passing a take marker in Play
2	B_INDEX	Index pulse, when passing an index marker in Play
9	B_STOP	Stop tally
3	B_PLAY	Play tally
10	B-READY	Ready for fader start operation
Others		
8	GND	Signal ground
11	VCC	Supply voltage (5 or 24 V <sub>DC</sub> )
15	KEY	

### 3.10.2 Fader Start

The D424 provides an opto-coupler input (with internal bridge rectifier and 20 mA current sink) for fader start operation. Use either an external voltage source of 5...24 VDC, or use the internal supply voltage. The polarity of the external supply voltage is of no importance.

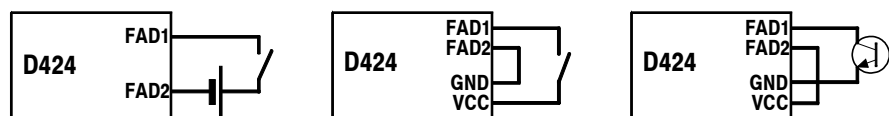

- Enable fader start operation with setup menu 45.
- When applying a control voltage at the fader input pins, the D424 will start, releasing the control signal will result in a STOP.

**Note:** During fader play operation, the local keyboard is disabled.

### 3.11 The Setup Menu

The [SETUP] command is used for entering the setup mode, in order to change parameters and to perform a number of utilities.

Navigation within a menu is done numerically or with the cursor keys:

[SETUP] [3] [1] – opens setup menu 31;

[◀] and [▶] – move to an item within a setup level (or control wheel);

[▲] and [▼] – go to the previous/next level or activate an item. [ENT] is an alternative to [▼].

For more detailed information on the setup menu see chapter 4.10 .

Menu Item	Display	Meaning	Parameters
<b>1</b>	<b>CONFIG</b>	<b>System configuration</b>	
11	S.FREQ	Sampling frequency	44.056, 44.1, 47.952, 48 kHz
12	S.WORD	Sample resolution	16, 20, 24, 24L bits
13	TC	Timecode format	24, 25, 29.97DF, 30, NONSTD
14	RECMODE	Record mode	stereo, mono
15	UNIT	Unit selection	unit1, unit2, unit3
16	DEFAULT	Configuration	
161	RECALL	Recall	User, PowerOn, Factory
162	STORE	Save curr. config to user setting	cancel, yes
17	REMOTE	Remote	local, remote
<b>2</b>	<b>REF &amp; INP</b>	<b>Reference &amp; input parameters</b>	
21	CLK SRC	Ref. clock source	int, dig, video
22	DIG REF	Digital reference	sync, wclock, audio
23	INPUT	Audio input	dig, analog, option
<b>3</b>	<b>AUDIO</b>	<b>Audio parameters</b>	
31	INP LEV	Analog input attenuator	inp1, inp2 (0...-14 dB)
32	OUT LEV	Analog output level	level (0...3)
33	DIG LEV	Digital playback level	channel1, channel2, (-12...+6 dB)
34	XFADE	Crossfade time	(0...2000) ms
35	METER	Meter mode	peak, peak hold
<b>4</b>	<b>TRANSPORT</b>	<b>Transport &amp; display parameters</b>	
41	MAXSPD	Maximum wind speed	(2...30) × nominal speed
42	VARISPD	Play varispeed	off, on (±12.5%)
43	AUTO	Auto stop	off, on
44	PRE/POST	Preroll/postroll	(2...40) s
45	FADER	Fader start1	disabled, enabled
46	REMAIN	Remaining time mode	auto, ind, take, seq
47	DISP RES	Display resolution	frames, ms
<b>5</b>	<b>DISK</b>	<b>Disk &amp; sequence utilities</b>	
51	SELECT	Select disk drive	(1...6)
52	SCSI	SCSI offline	yes, no
53	FORMAT	Format disk # ?	cancel, yes
54	CLEANUP	Cleanup disk # ?	cancel, yes
55	REN-SEQ	Renumber sequence ## )	cancel, yes
56	CLR-IND	Clear all indices of sequence	cancel, yes
57	DEL-FILE	Delete sound file DESTRUCTIVE	Seq #, take #, cancel, yes
<b>6</b>	<b>COPY</b>	<b>Copy utilities</b>	
61	WORK	Work copy seq ## to drv #	target, start
62	MASTER	Master copy seq ## to drv #	target, start
63	DISK	Copy disk # to drv #	target, start
64	XFER PAR	Transfer parameters	
641	SHAPING	Noise shaping	off, on
642	UPC/EAN	UPC/EAN code	1234 1234 12345
643	ISRC	ISRC code, track ##	abcde 1234567
644	CD MODE	CD copy mode	toc, multi, add, fix
645	DELAY	CD track delay	off, on
646	INDEX 0	Index 0 duration	off, on (2...5) s
65	FIXUP	Fixup disk # ? (for SADIe exchg.)	cancel, yes
<b>7</b>	<b>SERVICE</b>	<b>Service utilities</b>	
71	FORMAT	Format disk # ? (up to 40 min!)	cancel, yes
72	DATE	Date & time	day.month year hours:min

## 4 OPERATION

### 4.1 System Configuration

There is a number of configuration parameters in the D424 that are stored either in a battery-buffered RAM or on the disk. The default values of the D424 have been chosen for easy and safe operation.

After switching on the D424 for the first time, or after restoring the factory default values, the D424 is ready to be operated and to record from analog sources.

#### 4.1.1 Recording Formats

Before starting a new recording session, check the current status in the display.

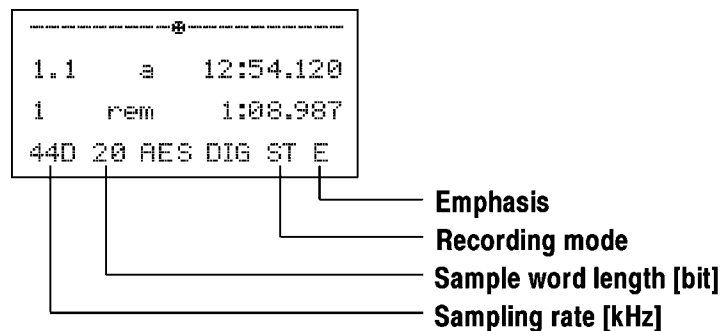

The parameters can be modified in the following setup menus:

- Menu 11: Sampling rate
- Menu 12: Sample word length
- Menu 14: Recording mode

**Notes:** It is possible to have different recording modes and sample word lengths in a single sequence. There are no restrictions in editing and transferring. However, only one sampling frequency is allowed per disk side. An error message will appear if the sampling frequency does not match with the format already existing on the disk.

The emphasis status a digital recording is stored to the disk together with the audio information. The status of the first take determines the status of a sequence. A warning will be displayed if subsequent recordings do not match with the emphasis status of the current sequence.

### 4.1.2 Audio Input

```

-----*-----
1.1   a   12:54.120
1     rem  1:08.987
44D 20 AES DIG ST E

```

Audio input

The input source is selected with the setup menu 23. Select “dig” for recording digital signals connected to the AES/EBU input, or “analog” for recording analog line signals at the LINE IN connectors.

**Notes:** The D424 has to be equipped with the analog I/O option for analog recording and playback.

Check the correct synchronization of digital sources and the D424 if recording digital audio. Both the source machine and the D424 have to be locked to the same reference (see the following section).

### 4.1.3 Reference Clock Source

The currently selected clock source is also shown in the display status line. In case of an external reference, the presence of a correct signal is indicated by a non-flashing clock source indication (INT, VID or DIG).

```

-----*-----
1.1   a   12:54.120
1     rem  1:08.987
44D 20 AES INT ST E

```

Clock source

#### Selecting the Correct Reference

There are the following settings for the D424 clock synchronization:

Mode	Setup menu 21	Setup menu 22	Reference input
Internal	int	-	-
Video	video	-	VIDEO
Digital, AES-11 ref.	dig	sync	AES/EBU SYNC
Digital, AES-3 audio input	dig	audio	AES/EBU IN
Digital, word clock	dig	wclock	WORDCKLOCK IN

- If the D424 is used in a analog environment, select the Internal Mode.
- If one or few digital machines are connected for playback or recording, and the peripherals can be locked to one of the D424's sync signals (Word Clock or Digital Audio) select the Internal Mode.
- If the other machines do not accept the D424's sync signals, connect one of the peripheral's sync signal to the D424, and select the corresponding Digital Mode.

**Note:** Be sure that the master machine is always switched on when operating the D424, and that it provides the reference signal in all conditions.

- If the D424 is integrated into a system with video and digital audio equipment, use a stable composite video reference as master for all machines. Switch the D424 to Video Mode.
- If a common high quality reference is available in a digital environment, use the corresponding Digital Mode. AES-11 and Word Clock are preferred.

#### 4.1.4 Other Parameters

---

There is a number of general parameters for

- remote operation
- storing user defaults
- timecode and display formats
- audio levels and editing parameters
- transport parameters.

They are accessible in the setup menu. Refer to the corresponding manual section for more details, or find a complete list of parameters and utilities in the setup menu section.



## 4.2 Display and Register Functions

### 4.2.1 Display Information and Formats

The standard display shows various information on 4 lines.

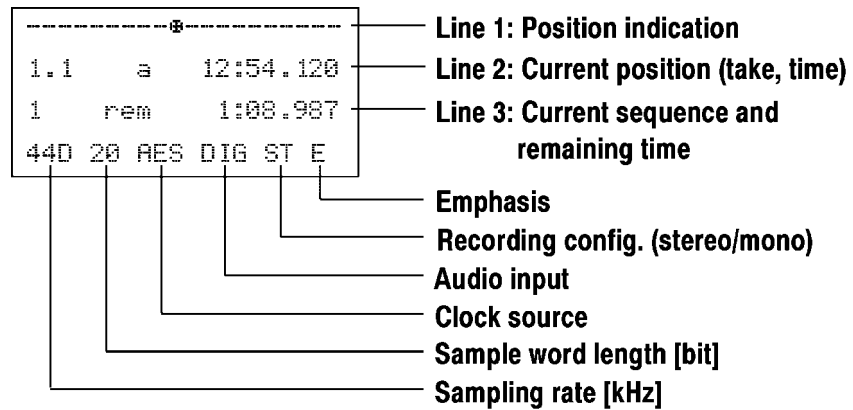

**Line 1**

- The position indicator at the top of the display is indicating the current position, relative to the selected sequence. It allows to see roughly where the recorder is, when controlling it with the transport commands.

**Line 2**

- The current take and index.
- Use the **[TAKE]** key to display either the take only, or take and indices.
- The selected time mode.
- Use the **[TIME]** key to display the current time in one of the following formats:

“a” Absolute time

“r” Relative time to take begin or last index marker

“t” Timecode.

- The current time.

The time field is showing the current position in hours, minutes, seconds and frames or milliseconds. Select either frames or milliseconds as display resolution with setup menu 47.

**Line 3**

- The currently selected sequence
- Following the “rem” indication, the field at the right shows the remaining time to one of the following points. Use setup item 46 to select:
  - the next take or index marker, depending on the take format
  - the next index marker
  - the next take marker
  - the end of the sequence.

The third line is also used for displaying alternative information. Depending on the current mode, the following information may appear instead of the remaining time:

“free” free recording time (during recording modes)

“to in”, “to out” countdown to IN or OUT point (during preview, auto record)

“var” current play varispeed (during varispeed operation)

“reg0”...“reg9” entry field for general purpose register (register editing)

“in”, “out” entry field for edit registers IN, OUT (register editing)

<b>Line 4</b>		The bottom line indicates the status of the main configuration and the current take parameters:
	<b>Sampling Rate</b>	44D 441 48D 48 Sampling frequencies include 44.1 kHz (441), 48 kHz (48) as well as the drop-frame formats 44.056 kHz (44D) and 47.952 kHz (48D).
	<b>Word Length</b>	16 20 24 Word length allows 16, 20, and 24 bit recording.
	<b>Audio Input</b>	AES ANA (OPT) Audio inputs are AES/EBU (AES), Analog (ANA) or further optional I/Os (OPT). With an appropriate adapter, the AES input will also accept SPDIF signals.
	<b>Clock Source</b>	INT VID DIG The following clock sources may be selected: Internal (INT), video (VID), and digital input (DIG). For detailed information see the System Configuration section.
	<b>Channel Configuration</b>	ST MON Files are either recorded in stereo (ST) or mono (MON) mode.
	<b>Emphasis</b>	E Digital signals with emphasis will result in a E status indication.
	<b>Time Format</b>	There are several sources for the current position within the sequence. With <b>[TIME FORMAT]</b> one of the following choices can be selected by toggling through the menu.
	<b>TC</b>	Timecode mode: The position is displayed referring to the recorded timecode. When a sequence consists of several takes with different timecode positions, the sequence timecode is derived from the first take's address. If no timecode was recorded at all, the absolute position is displayed instead, and the TC sign flashes.
	<b>ABS</b>	Absolute time mode: The absolute time position is displayed. It starts with 0 at the first recorded take and increases contiguously within the current sequence.
	<b>REL</b>	Relative time mode: The relative position to the beginning of the current take or the last index mark is displayed.
	<b>Take Format</b>	For displaying and accessing takes and indices, there are two different modes, selected with <b>[TAKE FORMAT]</b> :
	<b>TAKE</b>	Only takes are displayed; all operations are performed in units of complete takes or relative to take markers.
	<b>TAKE/INDEX</b>	Takes and indices are displayed, all operations are referring to take and index markers (e.g. skip to next index marker with <b>[NEXT]</b> ).

## 4.2.2 Using General Purpose Registers

There are several memory and editing registers that can be selected and modified. After being selected, a register may be modified or cleared with the numeric keypad, any changes are confirmed with the [ENT] key.

### Selecting/Modifying a Register:

The contents of any register appear in the display entry field if it has been selected.

```

-----#-----
2      a  1:12:54:10
1  reg1 23:59:59:24
441 16 AES VID ST

```

The edit registers (IN, OUT) may be addressed directly by pressing the respective key; all others (0...9) are selected with the key sequence [REG] [n], where n is one of the following registers:

<b>reg0</b>	Nominal offset register in chase mode,
<b>reg1...9</b>	General purpose registers, for use with the locator,
<b>IN</b>	Edit IN register,
<b>OUT</b>	Edit OUT register.

There are several ways to change the displayed value in the entry field (or the register contents):

1. Typing in a new value with the numeric keys [0...9]. With the first key-stroke, the display is automatically cleared.
2. Resetting the field to 0 with [CLR].
3. Modifying the displayed value with the control wheel.

All these modifications do not directly affect the register contents. The modified value is flashing, indicating that the entry field is different from the register contents, until it is stored with [ENT].

4. The current position is transferred to the selected register with [CAPT].
5. A register value can be incremented or decremented with the [▶] or [◀] keys by one display unit (ms or frame)

These two actions directly modify the register contents. Therefore, the field will not be flashing, and no termination with [ENT] is necessary.

The register programming mode can be cancelled anytime by pressing the initial select key [REG] [IN] or [OUT] once more. When terminating an entry with the [ENT] key, the display also reverts to standard mode.

### Transferring Registers and Locations

The contents of any other register may be transferred to a destination register by placing the machine to the desired position, and then transferring the location to any other register:

[LOC] [REG] [2] [REG] [0] [CAPT] – stores the value in register 2 to the nominal offset register.

### 4.3 Basic Transport Operation

The following basic transport commands allow to navigate the D424 to any point within the current sequence, and to playback audio files:

- [PLAY]** starts playback at the current position
- [STOP]** stops recorder at the current position
- [PREV]** moves to the previous take begin (or index marker)
- [NEXT]** moves to the next take begin (or index marker)
- [LOC]** moves to a predefined position
- [SHTL]** moves recorder forward or backward with a variable speed
- [CUE]** moves recorder forward or backward according to the control wheel position.

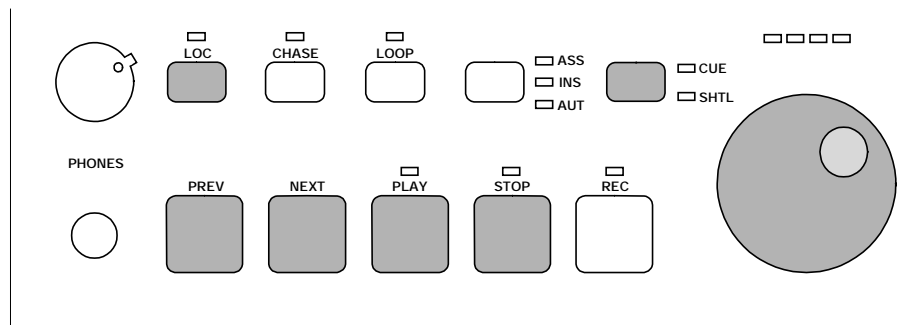

For easy access to random positions, index and take markers can be placed, moved, and erased. Two edit registers as well as nine general-purpose registers support efficient processing of editing and playback tasks.

#### 4.3.1 The Current Position

When playing back pre-recorded material, the operation is similar to a CD player or an R-DAT recorder. There is a current position within the sequence, defined in absolute time or timecode, from which the recorder can immediately reproduce audio.

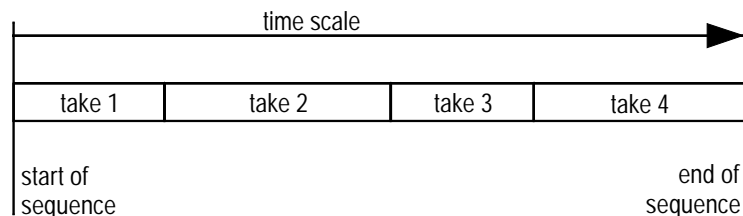

The current position within the sequence is indicated by a running indicator sign in the first line of the display. The far left position corresponds to the sequence start, the far right to the sequence end.

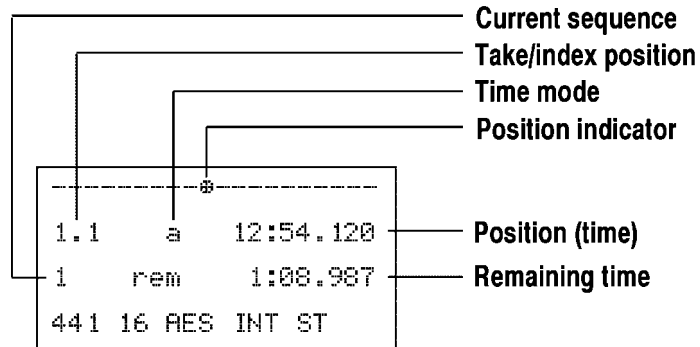

The second line displays the current take (and index) with the position in hours, minutes, seconds, and subdivisions.

The third line includes the current sequence number and the remaining time.

There are various display formats that can be adapted to the user's needs with a mode key or in the setup menu.

- Take/Index Format:** [TAKE]
- Time Mode:** [TIME]
- Remaining Time Mode:** Menu 46

Selects between displaying only take numbers, or take and index numbers.

Either the absolute, relative, or timecode position is displayed in line 2.

The remaining time is showing the time until the next “take” or “index” marker, until the end of the current “sequence” (in “auto” position, either the next take or index marker is referenced, depending on the take/index mode).

- Display Resolution:** Menu 47
- Timecode Format:** Menu 13
- Time Display Modes:** “a”

ms (milliseconds) or frames.

24, 25, 29.97 and 30 frames/second.

“a” is the absolute time. The contiguous time scale starts at the beginning of the sequence.

“r” means relative time. It indicates the position within a take.

“t” is the timecode position. If no timecode was recorded, the absolute position will be displayed with a flashing “t”.

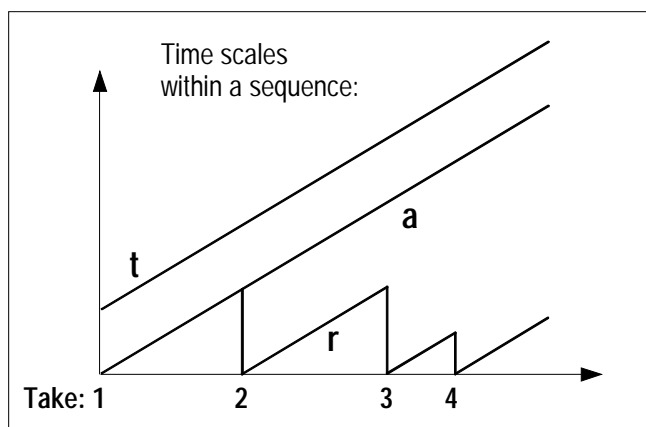

### 4.3.2 Playback and Stop

With **[PLAY]** the recorder starts to reproduce audio from the current position. At the end of the last take, the D424 stops automatically. **[STOP]** causes the D424 to stop at the current position.

### 4.3.3 Skipping to Take and Index Markers

Similar to CD players, locating to the previous or to the next take beginning (take marker) is possible with **[PREV]** and **[NEXT]**. At the new destination, the D424 starts playing if it was in playback before the skip command. Multiple commands are cumulated. If track/index mode is selected, skipping refers to index markers instead of take markers.

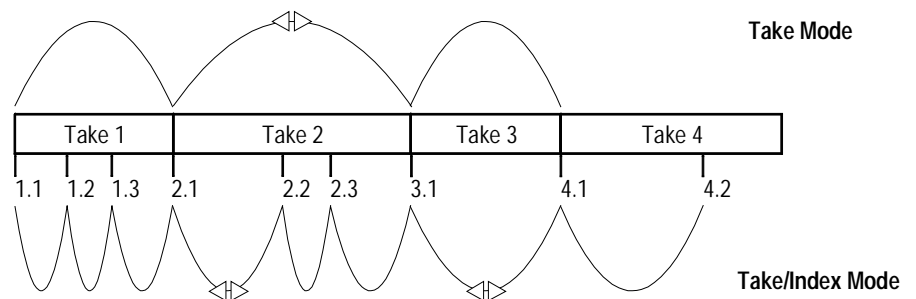

### 4.3.4 The CUE and SHUTTLE Modes

With the **[CUE/SHTL]** key, the mode that was used last is entered. Each subsequent keystroke toggles between CUE and SHTL mode.

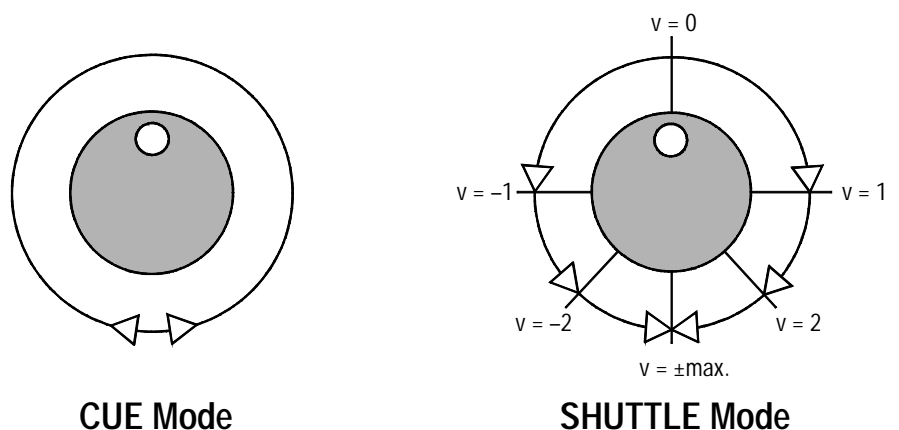

In the CUE mode, the position of the D424 is directly coupled with the control wheel. As with the reel of a tape recorder, a direct and precise tool for audible positioning is provided. It allows to search for a particular position by moving the D424 with the control wheel.

The SHTL mode allows to search for a particular position audibly by moving the D424's position at a speed in the range of 0...±2 times nominal speed. The speed is defined by the control wheel, the initial speed after selecting the mode is 0.

**LED Speed Indication:**

□ □ □ ■	fast wind forward
□ □ ■ ■	1...2 × $v_{nom}$
□ □ ■ □	0...1 × $v_{nom}$
□ ■ ■ □	still
□ ■ □ □	0...1 × $v_{nom}$
■ ■ □ □	1...2 × $v_{nom}$
■ □ □ □	fast wind reverse

At the upper and lower limits of the control wheel range, a maximum speed is applied (without audio output). This allows to “wind” the recorder to a target position, slowing down at the end, and positioning with low speed SHTL or CUE.

The present speed is shown in the display area, the LEDs above the control wheel indicate a rough speed overview.

As an alternative, full-speed shuttle mode is achieved with the following wind key combinations:

<b>[PLAY+NEXT]</b>	Fast forward mode,
<b>[PLAY+PREV]</b>	Fast rewind mode.
	Use <b>[STOP]</b> or <b>[PLAY]</b> key to leave the CUE/SHTL mode.

### 4.3.5 Locating to a Random Position

#### Locating to Take/Index Markers

Any take or index position in the sequence can be addressed in a simple way with the **[LOC]** key. The following keyboard entry is terminated either with **[ENT]**, with **[STOP]**, or with **[PLAY]**.

**[LOC] [2] [PLAY]** – will start playing at take no. 2

**[LOC] [5] [ENT]** – will park the D424 at the beginning of take no. 5

For accessing indices, simply add the index number:

**[LOC] [7] [IND] [2] [PLAY]** – will start playing at index no. 2 in take no. 7

**[LOC] [IND] [3] [PLAY]** – will start playing at index no. 3 in the current take.

#### Locating to Memory Positions

The D424 can be located to any position of the current sequence, if it has previously been stored in one of the memory registers.

To perform a memory locate, the **[LOC]** key is pressed, followed by one of the destinations indicated below:

<b>[IN]</b>	Edit IN register
<b>[OUT]</b>	Edit OUT register
<b>[PREV]</b>	Start of sequence
<b>[NEXT]</b>	End of sequence
<b>[REG] [1..9]</b>	General-purpose register 1...9

#### Examples:

<b>[LOC] [IN]</b>	Locate to edit IN point
<b>[LOC] [PREV]</b>	Locate to start of sequence
<b>[LOC] [REG] [3] [ENT]</b>	Locate to REG 3

## 4.4 Recording

The D424 has been designed to offer the well-known recording techniques from a tape recorder. But with a non-linear recording medium, new features in recording and editing become available. The D424 offers different recording modes, each offering certain advantages and flexibility.

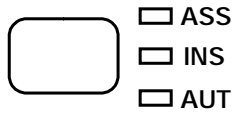

With the [ASS/INS/AUT] recording mode key, one of three recording modes is selected (see below). The corresponding LED will indicate the currently selected mode.

### 4.4.1 The D424 Recording Modes

**Assemble Mode** The assemble mode is similar to recording with a CD recorder. Every new recorded take is simply added at the end of the sequence. The identification number is increased by one, the absolute time continues at the end of the last take.

In the following example, there is a sequence with 3 takes, with the current position in take 2.

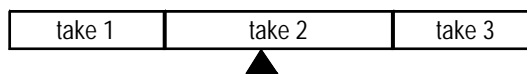

No matter where the current position is, recording one more take is simply done with [REC+PLAY]. The sequence will then look as follows:

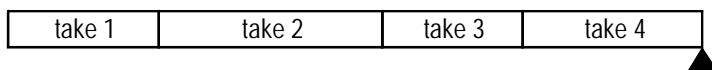

**Insert Mode** In insert mode, a destructive punch-in/-out is performed. The current data will be overwritten. The insert mode is therefore similar to the recording mode of a tape recorder.

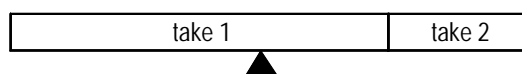

When performing a recording in the example above at the indicated position, take 1 would be overwritten until the punch-out command. Index markers are automatically placed at the punch-in and punch-out positions:

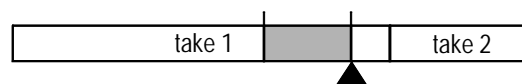

Take and index markers will be overwritten by new recorded elements.

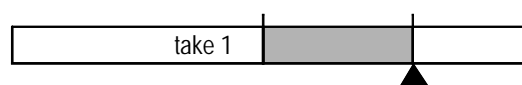

The sequence length is automatically adjusted, if necessary:

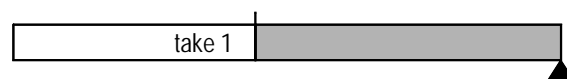



**Auto Insert Mode** The auto insert mode is similar to the insert mode. But instead of manually performing punch-in and punch-out commands, the record commands will be precisely executed when passing the IN our OUT points. Both edit registers are preset in advance.

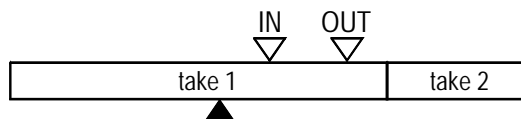

If at least one channel is set to READY, and a **[REC]** command is given, the D424 will start ahead of the IN point. It will show a countdown to the IN point, and a precise insert up to the OUT point is then performed automatically.

#### 4.4.2 Channel Assignments

**[RDY1]** and **[RDY2]** are the record enable keys. The ready condition is indicated by a flashing LED; during the recording process, this LED is continuously on.

If recording in STEREO mode, the **[RDY1]** and **[RDY2]** keys are linked, i.e. selecting one of them automatically activates both channels. In MONO mode, either **[RDY1]** or **[RDY2]** is selectable.

	RDY 1	RDY 2	
STEREO	ON	ON	Stereo recording (both channels linked)
MONO	ON	OFF	Mono recording from input channel 1
MONO	OFF	ON	Mono recording from input channel 2

**Note:** When playing mono recordings, the mono disk channel will be routed to both output channels.

**[INP1]** and **[INP2]** are assigning the source of the two audio outputs, which can be the disk (INPUT LED off) or the selected input source (INPUT LED on). During a recording process, the enabled channels are automatically switched to INP for monitoring purposes, the INP LEDs are then also switched on.

#### 4.4.3 Rehearse Mode

In both INSERT and AUTO INSERT modes, a rehearsal mode is available. It is activated with the **[PREVIEW]** key.

With the rehearse mode switched on, an insert recording process behaves exactly the same as a real recording, i.e. the monitor switches from disk to input during the recording period, but no data will be stored to disk.

#### 4.4.4 Meters

The meters either display in standard peak mode or in peak hold mode. In the latter case, the peak value can be reset with [**PEAK RESET**] or [**STOP**].

If the red overflow LED is on, a full scale digital value has been detected. The highest green LED indicates a level between  $-1$  and  $0$  dB.

#### 4.4.5 Adjusting the Analog Input Level

For recording from an analog source, the input sensitivity can be adjusted. For this purpose, the meters are switched to input either manually with the [**INP1**] and [**INP2**] keys, or by pressing [**REC+STOP**] (record pause mode).

The levels may then be modified in the setup menu 31.

With the Desktop Controller, there are separate keys for direct access to the level setting menu. Simply keep [**VOL1**] or [**VOL2**] pressed, and set the level with the control wheel.

Attenuation in setup menu [dB]	0.0	-0.5	-1.0	...	-13.0	-13.5	-14.0
Input sensitivity [dBu full scale]	10.0	10.5	11.0	...	23.0	23.5	24.0

#### 4.4.6 Before You Start Recording...

- Make sure that your system configuration is correct. All relevant data are shown in the status line of the display.

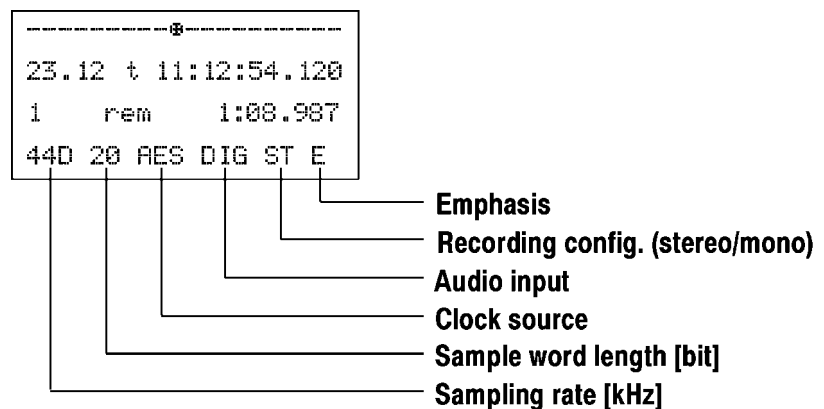

- Once set, it should not be necessary to modify the general parameters, because the remain stored when the D424 is switched off. In case of configuration errors indicated with a flashing status or an error message, please refer to the system configuration or the troubleshooting sections.
- Insert a disk with the write-protect tab in “write” position.
- Set the D424 to Record Ready. The disk will then be asked for the number of defective blocks, and a warning will appear if it is not in a safe range.

```

■■■■■■■■❖
2      a  1:23:54:10
1  free   25:46:23
44.1 16 AES VID ST

```

- You can see the available space for recording with a **[REC+STOP]** command. The top bar is an indication of the total recorded space, and the third line shows the time available for recording.
- Please note that the free recording time depends on the selected format: There is more recording time available with 16 bit resolution or with 44.1 kHz sampling rate, than with 24 bit resolution and/or 48 kHz sampling rate.
- Check the input level. The sensitivity of the analog input can be aligned to match your standard studio levels.

#### 4.4.7 Assemble Recording

Recording is simply started with **[REC+PLAY]** and stopped again with **[STOP]**.

```

■■■■■■■■❖
3      a  1:25:12:24
1  free   23:12:01
44.1 16 AES VID ST

```

During the recording process, the available recording space is displayed. If no disk space is available anymore, the D424 automatically stops.

The new take number appears in the position line (i.e. the 2nd display line).

Every new recording session is pasted to the end of the current session, regardless of the position before starting. A new take number is automatically assigned.

#### 4.4.8 Insert Recording

Insert recording allows to overdub existing recordings. It corresponds to the destructive recording mode of a tape recorder.

- Place the D424 to the beginning of the section to be replaced, and start with **[REC+PLAY]**,
- or*
- listen to the previously recorded material and punch-in on-the-fly with a **[REC+PLAY]** command.
- For a record punch-out, press either **[PLAY]** or **[STOP]**.

After performing an insert record, index markers are placed at the punch-in and punch-out positions, and the two points are automatically transferred to the IN and OUT edit registers for later editing.

#### 4.4.9 Auto Insert Recording

In the auto insert mode, an auto-triggered destructive record punch-in/-out is performed at the current IN and OUT positions.

The mode is started like a normal recording by pressing [REC+PLAY]. The D424 then automatically starts at (IN minus PRE-ROLL). As soon as it is passing the edit points at nominal speed with at least one channel set to READY, a precise punch-in at the IN point and a punch-out at the OUT point are performed. The auto record process is stopped at (OUT plus POST-ROLL).

The auto insert can be previewed by activating the rehearse mode with the [PREVIEW] key before starting the process.

```

#-----
2.1  a      4:10
      to IN  3:12
auto RECORD
  
```

```

■■■■■■■■■#
2.1  a      5:15
      to OUT  0:12
auto RECORD
  
```

```

#-----
2.1  a      7:22
      from OUT 1:07
auto RECORD
  
```

The auto insert process is indicated in the display, a countdown to the next edit event replaces the remaining time display.

**Note:** When using several attempts to replace a part of the session with Auto Insert, all versions are stored on disk. As a result of the non-destructive editing, they are not deleted automatically and can be accessed in Sequence Editing later. Use the CLEAN-UP tool in the Setup menu to delete all unused files, when the production is fixed.

## 4.5 Editing

In addition to the standard recording modes, non-destructive editing is provided. It is possible to cut out or delete a part of a sequence, and to move or copy a source element to any destination.

For all editing processes there is a source element that has to be specified. It is identified with a register pair IN and OUT. For some of the editing features, an additional insert position is required, marked by a target point.

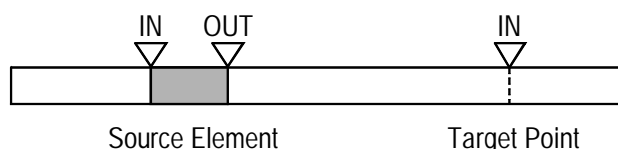

All source operations are performed in the source editing mode selected with **[SOURCE]**. For target-related functions, the target mode is switched on with **[TARGET]**.

There are three main editing functions that can be combined for more complex processes:

**CUT** A source audio element is cut out of a sequence. It has the same effect as cutting out a piece of tape and splicing the two ends.

**ERASE** A source element is erased, i.e. the audio element is filled with silence.

**INSERT** A marked source element is inserted at the target position.

Editing usually consists of the following steps:

- The source element is defined by setting the IN and OUT points
- The settings for the source element can be audibly checked with PREVIEW functions. If necessary, the edit points are adjusted.
- In case of an INSERT the target point is set in the same way.
- The process is executed with **[CUT]**, **[ERASE]**, or **[INSERT]**.
- If an edit process has been executed by mistake, it may be cancelled afterwards with **[UNDO]**.

### 4.5.1 Setting IN and OUT Points

The SOURCE IN, SOURCE OUT, and TARGET IN edit points can be edited in different ways. In general, the positions can be searched for with the transport commands, or they can be set and trimmed off-line with the numeric keypad and the control wheel.

The source points are selected with the **[IN]** and **[OUT]** keys, either in source mode, or with source and target mode switched off.

The target point is selected with the **[IN]** key when in target mode.

**Setting a Point “On-the-Fly”** An edit point can be set by listening to the material and simply storing the current position with a keystroke. For this reason, the **[CAPT]** key copies the sequence time to the selected edit register.

**Example:** *Defining the source element:*

**[PLAY]** – Start listening to the source

**[IN]** – Select SOURCE IN point

... **[CAPT]** – Copy the current position to the IN point

**[OUT]** – Select SOURCE OUT point

... **[CAPT]** – Copy the current position to the OUT point.

**Searching for a Point Audibly**

By means of the transport commands – especially with the control wheel – the correct edit position is first searched for. If it has been found, the position is transferred to the edit register again with the [CAPT] key.  
 When working with the control wheel, the sequence may look like this:  
 [TARGET] [IN] – select TARGET IN point  
 [CUE/SHTL] + **control wheel** – search for insert point with CUE/SHTL  
 [CAPT] – copy the position to the edit register

**Trimming a Register Setting**

For minor modifications of a setting, points can easily be trimmed with the cursor keys or the control wheel.  
 [OUT] – select source OUT point  
 [▼] and [▲] – trim OUT register  
 [IN] – select source IN point  
**Control wheel** – modify the current value  
 [ENT] – and save it to IN

**Entering New Values**

If the correct position is known by position from an existing list, or if points should be roughly defined before accurate tuning, the position can be entered like any other register.  
 [IN] – select source IN point  
 [0...9] or [CLR] – enter a new value with the numerical keyboard  
 [ENT] – and store the entry to IN

**Note:** Trimming with the cursor keys automatically stores the modified values to the register. Keyboard entries and modifications by the control wheel are stored with a subsequent [ENT] command.

4.5.2 The CUT Function

For cutting out an element within the sequence, first the source element is defined by setting the IN and OUT registers. When the source editing mode is selected with [SOURCE], the currently selected element is indicated in the display.

```

-----*-----
2      a  1:12:54:100
src IN   1:12:05:000
      OUT 1:12:09:500
    
```

A [CUT] command then removes the source element; the audio information before and after the element is joined directly.

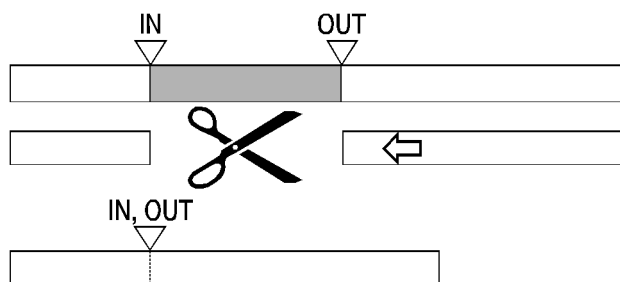

All markers located within the source element will also be removed. A new index marker is placed at the removed source element's position.

4.5.3 The ERASE Function

For erasing an element, first the source element is defined by setting the IN and OUT registers. An **[ERASE]** command then deletes all audio information between the IN and OUT points.

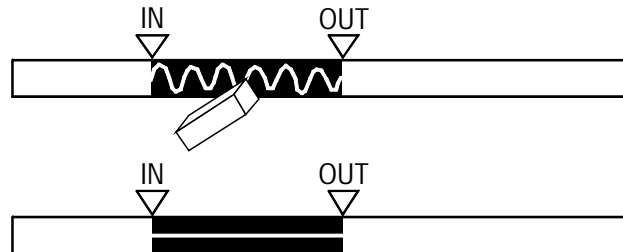

Neither the length of the sequence nor the take and index markers between the IN and OUT points are affected.

4.5.4 The INSERT Function

For the INSERT function, an additional point is required: the TARGET IN point. When selecting the target edit mode with **[TARGET]**, the SOURCE IN point and the insert position (TARGET IN) are displayed.

```

-----*-----
2      a  1:12:54:100
src IN  1:12:05:000
tar IN  1:12:55:500
    
```

The **[INSERT]** command simply copies the source element to the target position.

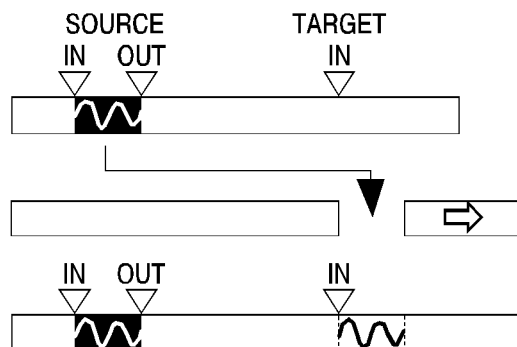

4.5.5 Combined Editing Processes

Taking the above basic functions, various combinations allow moving and copying elements in a sequence. The source and target modes are mutually exclusive; switching between them is possible at any time with the [SOURCE] and [TARGET] keys. Leaving the editing mode is possible by pressing the active edit key again.

All insert functions refer to the currently selected source element.

**Copying an Element**

1. A source element is selected in source editing mode.
2. After changing to the target mode, the selected element may be inserted once or at several addresses.

**Moving an Element**

1. A source element is selected in source editing mode.
2. After changing to the target mode, the selected element is inserted at the new position.
3. The source element is then removed in source mode with [SOURCE] [CUT].

4.5.6 The PREVIEW Function

During adjusting the edit points, or as a final check before performing a CUT, ERASE, or INSERT, all settings can be previewed in advance. Rehearsing is started with the [PREVIEW] key while being in the edit mode.

```

-----*-----
2.1   a  1:12:54:10
      to IN   3:12
preview CUT
    
```

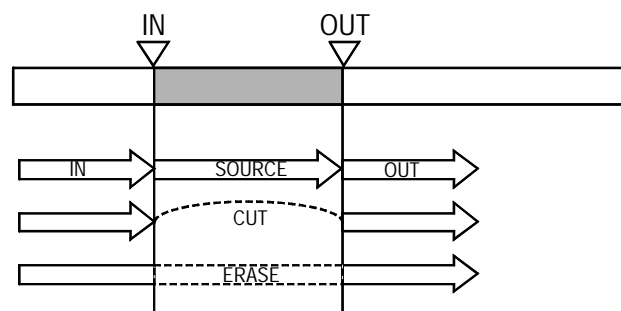

The following functions are provided for CUT and ERASE in the source mode:

[PREVIEW] [IN] – The pre-roll element before the IN point is played.

[PREVIEW] [OUT] – The post-roll element following the OUT point is played.

[PREVIEW] [SOURCE] – The complete source element (between IN and OUT) is played

[PREVIEW] [CUT] – The cut process is rehearsed by playing the preview IN and OUT elements in sequence.

[PREVIEW] [ERASE] – The erase process is rehearsed by playing the preview IN element, the muted source element, and the preview OUT element in sequence.



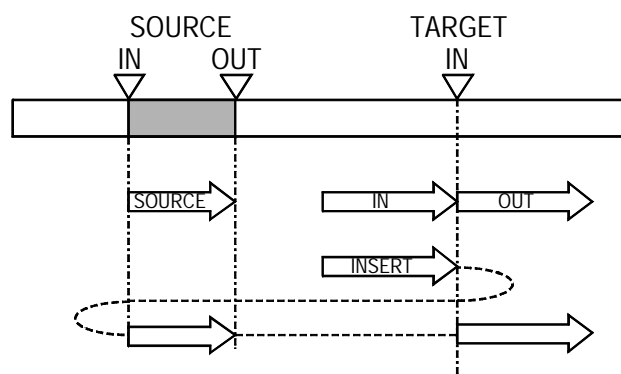

The following functions are provided for INSERT in the target mode:

**[PREVIEW] [IN]** – The pre-roll element before the TARGET IN point is played in target mode.

**[PREVIEW] [OUT]** – The post-roll element following the TARGET IN point is played in target mode.

**[PREVIEW] [SOURCE]** – The complete source element that will be inserted is played

**[PREVIEW] [INSERT]** – The insert process is rehearsed by playing the preview IN element, the insert element, and the preview OUT element in sequence.

The preview process can be stopped at any time by pressing **[PREVIEW]** again, or with a **[STOP]** command.

## 4.6 Sequence Editing

The sequence editing mode allows to select, create, and edit user sequences. It is selected with the **[SEQ]** key.

The display changes to the sequence select mode, first waiting for a sequence number. The ones available on the inserted disk are listed at the top. If there are too many takes, they will be displayed as a running sequence.

```
available sequences:
1 2 3

seq _
```

### 4.6.1 Selecting a Sequence

An already existing sequence number can be typed in. After confirmation with **[ENT]**, the selection is made, and the display reverts to the standard mode.

```
⊕-----
1      a      0.000
3      rem    53:08.987
441 16 ANA INT ST
```

Quitting the selection mode without changing the current sequence is achieved with a further **[SEQ]** command.

### 4.6.2 Creating a New Sequence

If a new number is entered that is not listed in the available sequence list yet, a new sequence will be created with the corresponding number: **[SEQ] [4] [ENT]**

If no number is entered at all, a new sequence with the lowest available number will be created: **[SEQ] [ENT]**.

When confirmed with **[ENT]**, the new empty sequence is selected as the current one, and the display reverts to standard mode.

```
⊕-----
1      a      0.000
3      rem    0.000
441 16 ANA INT ST
```

### 4.6.3 Deleting a Sequence

A sequence may be deleted by selecting it, and by performing a “Cut All” command with the key combination **[TARGET+CUT]**.

#### 4.6.4 Editing a Sequence

The sequence to be edited – either an existing one, or a new, empty one – is selected by typing in the corresponding number (or nothing) followed by **[SOURCE]** or **[TARGET]**.

As default, the source sequence from where takes can be copied will be the table of contents of the current disk (sequence 0). Each source take corresponds to a sound file.

When takes from any other sequence should be copied, they have to be assigned before entering the editing mode. With the **[▶]** key the source sequence field (from...) is selected, and any sequence number may be entered.

```
available sequences:
1 2 3 4 5

seq 6          from 2
```

The sequence editing mode is entered with a **[SOURCE]** or **[TARGET]** command: **[SEQ] [3] [▶] [2] [SOURCE]**.

The following display will appear:

```
1-2-3-4-5-6
source 02 take 01
target 03 take 03
1-2-3
```

The source sequence (from where takes are copied) and the target sequence (the sequence that is edited) are listed in the first or last line, respectively.

Lines 2 and 3 show the currently selected sequences with a source take and a target take position.

Now, the take in the source sequence that should be copied can be entered. The destination insert point is defined by switching to the target line with **[TARGET]**, and typing in the corresponding take number before the insert point.

If there is not enough space in the line to display all takes, a page with the currently entered take in the center of the line is automatically shown. Arrow signs indicate that there are more takes at the left or at the right of the current page.

It is possible to switch between source and target definition with the keys **[SOURCE]** and **[TARGET]** before performing an edit process. The active half of the display is indicated with brighter digits, the entry field with flashing digits.

With **[INSERT]** the source take is inserted after the target take.

With **[CUT]** the target take is deleted from the selected sequence.

**Examples:** *Insert take 3 from sequence 2 after take 4 in sequence 3:*  
 [SEQ] [3] [▶] [2] [SOURCE] – define sequences and enter editing mode  
 [3] [TARGET] [4] [INSERT] – define takes and insert.

*Delete take 5 from sequence 1:*  
 [SEQ] [1] [TARGET] [5] [CUT] – define sequence and enter editing mode, select target take and delete it.

With [TARGET+CUT] the current sequence file with all takes will be deleted.

With [TARGET+INSERT] the complete source sequence will be copied to the target sequence. Existing takes in the target sequence will be overwritten.

Leaving the sequence editing mode is possible in any state with a [SEQ] command.

**Notes:** When entering the sequence editing mode, the source take is set to the first take of the source sequence, the target take to the last take of the edited sequence.

After an INSERT command, the source take is incremented to the next take of the source sequence, the target position is after the take just inserted. This will allow to copy a sequence by simply pressing [INSERT] several times.

After a [CUT] command, the indicated take will be the take before the removed one. Performing several [CUT] commands in sequence will result in deleting a sequence take by take (in reverse direction).

All take selections can also be done with the [▶] and [◀] cursor keys or with the CUE/SHUTTLE wheel.

**Examples:** *Switch to sequence 2:*  
 [SEQ] [2] [ENT]

*Create a new sequence with all files from toc*  
 [SEQ] [▶]  
 [SOURCE] [TARGET+INSERT]  
 [SEQ]

*Insert take 3 and 4 (sequence 2) after take 4 in sequence 3:*  
 [SEQ] [3] [▶] [2]  
 [SOURCE] [3] [TARGET] [4] [INSERT] [INSERT]  
 [SEQ]

*Delete takes 5, 6 and 7 from sequence 1:*  
 [SEQ] [1]  
 [TARGET] [7] [CUT] [CUT] [CUT]  
 [SEQ]

*Create a new sequence 3 as a copy of sequence 1:*  
 [SEQ] [3] [▶] [1]  
 [SOURCE] [TARGET+INSERT]  
 [SEQ]

*Delete sequence 3:*  
 [SEQ] [3]  
 [TARGET+CUT]

## 4.7 CD Transfer and Disk Copies

The D424 MO recorder is equipped with a SCSI port. Additional external MO drives and/or CD writers may be connected to perform fast data transfers.

### 4.7.1 Configuration

For making copies between the D424 and external drives, a SCSI connection between the two devices has to be established.

Please follow the instructions below for correct operation:

- Switch off the two units and connect the SCSI cable.
- Make sure that the two units do not have the same SCSI address. The default address of a D424 is “1”, the one of the Studer D741 is “2”. See the corresponding manual section of the device for changing SCSI addresses.
- Switch on the peripheral device first. If it is not a single peripheral drive (disk drive only), switch it to SCSI slave mode (Studer D741: SCSI ON, D424: SCSI offline mode).
- Switch on the D424.

### 4.7.2 Transfer to a CD Writer

The CD transfer option is the solution for small CD mastering applications. It allows to copy sessions having been edited in a D424 sequence to a CD writer.

The copy utility not only transfers audio data, but also additional PQ information. The transfer is performed with double speed.

#### What will be Transferred?

The audio data are transferred in one of the following modes:

- |              |  |
|--------------|--|
| <b>TOC</b>   | A complete sequence is transferred to a new, empty disc, including all defined PQ information (disc-at-once mode). The CD is finalized and ready for use on any CD player. |
| <b>MULTI</b> | Same as TOC, but the CD is multi-session expandable (for use on PC systems).   |
| <b>ADD</b>   | The current sequence is added to the CD-R contents. The table of contents of the disc will not be finalized, it will be therefore ready for further subsequent transfers.  |
| <b>FIX</b>   | No data are transferred. A CD-R that has been recorded in “add” mode will be finalized.  |

The D424 supports editing of the PQ data listed below, that are copied to the CD in addition to the audio data of the currently selected sequence. They can be set in the TRANSFER PARAMETER menu 64.

#### Take and Index Markers

The take and index markers that were set in the D424's current sequence will appear in the CD-R at the same position.

The take markers of the D424 correspond to CD tracks.

#### ISRC and UPC/EAN Codes

There is a separate menu item in the COPY menu for defining the CD's catalog number – the UPC/EAN code – and the ISRC code of each track.

#### Control Data

The emphasis flag of the current sequence is copied to the CD writer as well, all other control data are set to 0.

<b>Noise Shaping</b>	<i>Further parameters are considered for a data transfer to a CD recorder:</i> For improved audio quality when transferring 20 bit or 24 bit data to a 16 bit CD.
<b>Track Delay</b>	For inserting a delay of 100 ms between track begin and audio, to improve readability of CDs on consumer players.
<b>Index 0 Pause</b>	When transferring in “toc” mode, an additional pause (index 0) of 2...5 s can automatically be inserted between tracks. In “add” transfer mode, the Studer D741 always generates pauses of 2 seconds.

### Starting the Transfer

- The transfer process is initiated in the SETUP menu. After having edited the current sequence and checked the parameters, select MASTER COPY menu 62: [SETUP] [6] [2]

```

Master Copy
seq 01 to Drv 2
cd mounted
target start

```

- The indication “cd mounted” will confirm that the communication between D424 and the CD writer is working properly.
- Start the process by moving to the “start” item with the cursor keys, and confirm with [ENT].
- During the entire transfer process, the indication “processing” and a progress bar with “#” signs will inform you on the transfer status.
- As soon as the transfer is finished, the display will revert to standard mode. If a “toc” transfer has been made, the CD writer will open its disc tray.

**Notes:** Do not interrupt a SCSI transfer by disconnecting or switching off one of the two units. The current session on the CD-R might be damaged. The D424 will check if the CD-R has sufficient capacity for doing a disk-at-once transfer of the current disk. An ERROR message will appear if the sequence is too long. In ADD mode, the capacity check is made “take by take”. The transfer process is stopped automatically when the CD-R is full. The D424 does not accept more than 99 indices for a single disk-at-once transfer. If the required number is higher, multiple ADD transfers have to be used. Finalizing a CD will take 2...3 minutes. Do not interrupt the process. The display will revert to standard mode as soon as the process is finished.

### 4.7.3 Copying a CD to the D424

The contents of a CD can be copied to a new sequence on the D424 disk, including the track information.

#### What will be Transferred?

The following transfer modes are available:

**TOC** The complete CD will be copied into a new sequence on the target disk. Every track is stored as a separate sound file. The take markers in the new sequence correspond to the CD tracks.

**ADD** The CD track currently selected is transferred. A new sequence is created on the target disk with the single CD track.

*No further transfer parameters are considered.*

#### Starting the Transfer

- Check that the inserted MO disk is ready for recording the CD tracks – it should not be write-protected, have enough free capacity for adding the information, and the format should be CD compatible (44.1 kHz).
- Select the CD drive as active drive (setup menu 51). Select the desired transfer mode in menu 644. If transferring a single track, locate the CD to the corresponding track by using the D424 transport keys.
- The transfer process is then initiated in the SETUP menu. Select the MASTER COPY menu 62: [SETUP] [6] [2]

```

Master Copy
seq 01 to Drv 2
cd mounted
target start

```

- The indication “cd mounted” will confirm that the communication between the D424 and the CD writer is working properly.
- Start the process by moving to the “start” item with the cursor key and confirming with [ENT].
- During the entire transfer process, the indication “processing” and a progress bar with “#” signs will inform you on the transfer status. After a successful transfer, the display reverts to standard mode.
- Reselect the internal MO drive as current drive (setup menu 51); you will find a new sequence with the audio information just transferred from the CD.

#### 4.7.4 Copying to/from Other Disks

Sequences and complete disks can be copied from the internal drive to additional, external drives.

**What will be Transferred?**

The following transfer modes are available:

- DISK COPY** Will copy the complete disk. The target disk has to be empty; reformat it first, if necessary (setup utility 53).
- MASTER COPY** Will create a new sequence on the target disk. The audio information will be merged into a new, single sound file.
- WORK COPY** will create a new sequence on the target disk that is identical with the source and includes all sequence information. All sound files that are used by the sequence will be transferred as well.

*The following additional parameters will be considered for the MASTER COPY mode:*

- Noise Shaping** (in TRANSFER PARAMETER menu 641); for improving data quality when transferring 20 bit or 24 bit data to a 16 bit sequence.
- Recording Parameters** With MASTER COPY a new audio file is generated. Some of the basic recording parameters are considered.
- Digital Playback Level** The transfer process considers the digital playback level setting in setup menu 33.

**Starting the Transfer**

- Check that the target MO disk is ready for recording – it should not be write-protected and should have sufficient free capacity for adding the prepared audio.
- The transfer process is initiated in the SETUP menu. After having edited the current sequence and checked the parameters, select one of the COPY menus 61...63, e.g. [SETUP] [6] [3]

```

Copy Disk 1
      to Drv 4
target      start
    
```

- The current source and target information is displayed. The target disk can be changed by selecting the “target” item.
- Start the process by moving to the “start” item with the cursor key and confirm with [ENT].
- During the entire transfer process, the indication “processing” and a progress bar with “#” signs will inform you on the transfer status. After a successful transfer, the display reverts to standard mode.



4.7.5 Transfer Parameters

There is a number of transfer parameters that can be modified to meet the requirements of different applications. All settings can be accessed in the TRANSFER PARAMETER menu 64.

**Noise Shaping (Menu 641)** For making best use of high quality recordings in 20 or even 24 bit resolution, it is possible to apply the noise shaping algorithm to audio information for transfer to 16 bit media.

*If set to OFF, audio data will be truncated to 16 bits.*

**UPC/EAN (Menu 642)** The UPC/EAN code is a catalogue number for CDs (13 digits). The indicated number is read from the inserted CD, modifications are possible only as long as no code was programmed yet (code is 0).

**ISRC (Menu 643)** International Standard Recording Code (5 alphanumeric and 7 numeric digits), including country and owner identification, recording year, and serial number.

There is one ISRC code for each take. If cleared, no UPC/EAN is recorded.

**CD MODE (Menu 644)** One of the following modes can be selected:

- TOC Disc-at-once transfer, including table of contents
- MULTI Same as TOC, but multi-session expandable
- ADD Add the current sequence without table of contents
- FIX The CD is finalized (table of contents, no data transfer)

**CD TRACK DELAY (Menu 645)** When starting a consumer CD player, it usually takes some time before the circuit is stable and the output is unmuted. For being sure that the complete audio information is played when starting from a cue position, the waiting position has to be a certain time before the audio start position.

For that purpose, the CD track delay feature can be used. When it is enabled, the begin of index 1 of each track is placed 100 ms ahead of the previous position (audio start position).

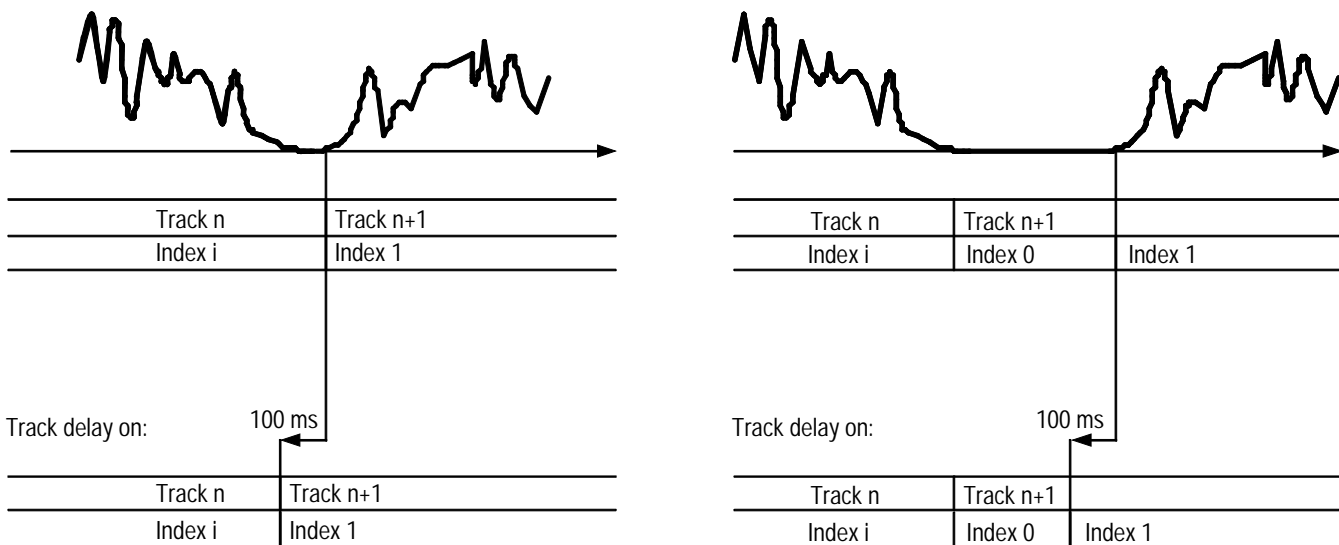

If there is no pause (index 0), moving index 1 is identical to moving the track begin.

**INDEX 0 DURATION (Menu 646)** Commercial CDs often have an invisible “index 0” part between two tracks. It allows to have a pause when playing the 2 tracks in sequence, but also to indicate the end of a track with the track signal and to start immediately when paused at the begin of the following one.

When transferring sequences from the D424 to the CD writer, a pause of 2...5 seconds may be inserted between the tracks. This is useful when constant pause periods with index 0 are required.

If individual pause times are required, they have to be inserted when editing the sequence. Transferring is then performed with no additional “index 0 pause” (parameter = 0). The CD will then be recorded without index 0.

When inserting a pause between two tracks, cross-fades are usually applied similar to insert recording. No additional cross-fades will be added, when there already is a cross-fade section at the take begin (e.g. take has been defined by a new record start, or a pause has been inserted manually).

**Note:** In ADD mode, the Studer D741 will generate pauses of 2 seconds regardless of the D424 settings. Use the “toc” mode for transferring sequences with continuous transitions from one take to the other (e.g. live concerts).

#### 4.7.6 SCSI Addresses

---

The addresses of SCSI peripherals have to be unique. The SCSI host of the D424 core board is on address “7”, the default address of the internal MO drive is “1”. The default address of the Studer D741 CD recorder is “2”.

The address of an additional external drive may be set to any address between 1 and 6, except the address of the D424's internal drive.

If connecting several D424 MO recorders with a SCSI cable, the address of the additional recorders has to be adapted. See the troubleshooting section for the modification of the D424's internal drive.

The address of the Studer D741 may be changed at the DIP switch near the SCSI connectors on its rear panel (for details see Studer D741 Operating Instructions).

For changing the SCSI address of other CD writers, please consult the corresponding manual.

## 4.8 Backup Copies

---

When working on projects for several days, backup copies of the current projects may be made either on the same disk or on a separate, external disk. We recommend, as with any other computer-based data processing program, to perform backups on a regular basis. There are two backup methods with the D424.

### 4.8.1 Sequence Backup

---

With a sequence backup, the sequence file with all the editing information is simply copied onto the same disk.

**Example:** Copy the current sequence 1 into a new sequence 2  
 [SEQ] [2] [▶] [1] – Create a new sequence from sequence 1  
 [TARGET+INSERT] – Copy all takes.

It is very easy to switch between different versions of the same production by selecting one of the available sequences as the active one.

**Example:** Select sequence 4 as the active sequence  
 [SEQ] [4] [ENT] – Select sequence 4 and return to main mode.

The disk contents may look like this:

<i>Sequence 1</i>	Original recording session, without any modifications
<i>Sequence 2</i>	Final pre-edited version after the first day
<i>Sequence 3</i>	1st version based on sequence 2
<i>Sequence 4</i>	2nd version based on sequence 2
<i>Sequence 5</i>	Special mix for customer A.

**Notes:** With a sequence backup, the sequence file with all the editing information is simply copied onto the same disk. The audio data remain unchanged and are referred to by all the different sequences

For more information on sequence editing, see the corresponding section above.

---

## 4.8.2 Disk Backup

---

When there is additional disk drive available (or a second D424 recorder), the contents of the current sequence with audio and editing data may be copied onto a separate backup disk.

For setting up the system, the following steps are required:

- Switch off both units and install the SCSI cable between both units. The termination of the destination drive must be on. In case of the D424, termination is provided automatically.
- Switch on the destination drive. In case of the D424, switch it to SCSI offline mode in menu item 52.
- Switch on the D424. It will automatically recognize the connected SCSI destination.

After having started your system, the following steps are necessary for transferring the current sequence onto the destination disk:

- Be sure to be in the sequence you would like to copy.
- Select the “work copy” mode with **[SETUP] [6] [1]**.
- The target drive is listed in the menu page. If it is not yet correct, select the “target” item, select the desired target drive and confirm with **[ENT]**.
- Start the transfer by selecting the “start” item.

During the transfer, the display indicates “processing”. When the transfer is completed, the display reverts to the standard mode again.

**Note:** The information on the destination drive is not overwritten. The new sequence is simply added to the contents of the disk. A warning will appear if there is not enough space on the destination drive.

## 4.9 Data Exchange with SADiE® Workstations

---

The audio data files (\*.WAV) recorded on a D424 can be read by almost every DOS-based workstation. With SADiE® digital audio workstations, a further compatibility level is provided. The EDL files with all the editing and disk structure information can be shared between the two products.

It is therefore possible to record and edit on a D424, do some more sophisticated editing on the DAW, and play the final product again on a D424 without losing the editing information.

### 4.9.1 DAW Configuration

---

	SADiE® software version 1.3, equipped with ISO MO drive 2.6 GB.
<b>SETUP</b>	Sampling rate according to recording session on disk, 16 bit resolution
<b>MIXER1</b>	Stereo stream
<b>PLAYLIST</b>	Two streams

### 4.9.2 Importing D424 Disks to the DAW

---

The D424 sequence files including all information for playing sequences are converted into the common SADiE® interchange format. Because the large audio files do not have to be translated, the conversion process only takes a short time.

Use the FIXUP utility in setup menu 65 to start the translation. If the process is finished, remove the disk from the D424.

Insert the disk into SADiE's MO drive and import the D424 data in the following way:

- Select the Disk Manager in the file menu, press the right mouse button and select "Log Disk"
- Select "SCSI DOS transfer" in the file menu.  
The D424 MO disk will be listed.
- Copy the EDL file (filex.EDL) to your project directory on the PC's hard-disk.
- Select the menu item "File – Convert".
- Select input file "filex.EDL" (the D424 EDL file), select output file "to playlist".
- Continue working with the DAW, and save your session as usual.

#### What You Will See (and What You Won't):

You will see all takes and editing effects made on the D424 with 16 bit files; the DAW does *not* consider any 20 bit and 24 bit files.

### 4.9.3 Importing SADiE® Disks to the D424

---

Create the EDL file with SADiE® interchange format, and copy the file to the MO disk.

- Convert from “Playlist” into the EDL file (filex.EDL)
- Select “Copy DOS to SCSI” in the file menu – select filex.EDL to MO disk; always copy the EDL file to the main level, do not use any subdirectories.

Close the SADiE® project and remove the disk.

- Select the Disk Manager in the file menu, press the right mouse button and select “unlog disk”.
- The disk can now be inserted to the D424. It will automatically detect the interchange file and reconvert it to a standard sequence file. You can switch to the new sequence by typing [SEQ] and selecting the new sequence file.
- Continue working with the D424as usual.

#### **What You Will See (and What You Won't):**

You will see all markers and edits done by the SADiE® workstation; you will not have access to files located on the DAW's harddisk.

## 4.10 Setup Menu

### 4.10.1 Accessing and Modifying Menu Items

With **[SETUP]** the display changes to the setup mode, where different types of parameters and functions are available. The same key is used to leave the setup mode again.

All parameters and utilities are identified with a unique number. The setup menu has a hierarchical structure. It allows to directly access an item with its number, or to be guided through the necessary menu levels.

**Direct Access** The fastest way to access menu items is by specifying their number directly after the setup command.

**[SETUP] [3] [1]** – opens menu 31 (analog input attenuation).

**Cursor Access** A menu structure allows to find particular items by navigating through the multiple levels with the cursor keys. After the **SETUP** command, the main menu is opened. Any item of the menu structure can be accessed with a number of cursor commands.

**[◀]** and **[▶]** move to an item within a setup level. The control wheel can be used as an alternative to the cursor keys.

The currently selected item is highlighted, its number is flashing.

**[▲]** and **[▼]** go to the previous or the next menu level.

When several parameters have to be modified, it is usually faster to use the cursor keys to change from one item to the next one.

#### Modifying and Executing Items

Each menu page lists up to 8 items. There are several types:

- Submenu items lead to the next menu level when selected with the **[▼]** cursor or the **[ENT]** key.
- Utilities will be executed when selecting the corresponding “yes” or “start” item with the **[▼]** cursor or the **[ENT]** key.
- Numerical parameters items are selected with the **[▼]** cursor or the **[ENT]** key.
- After the selection, the current value starts flashing. A new entry can now be made by means of the numeric keypad and CLR, or by trimming the current setting with the control wheel or the **[◀]** and **[▶]** cursor keys. The entry is terminated with **[ENT]**.

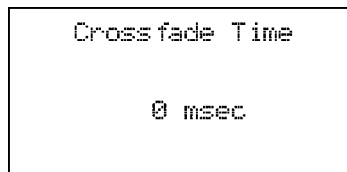

- If a parameter page contains a list of presets to select from, each position has a position sign (◻).

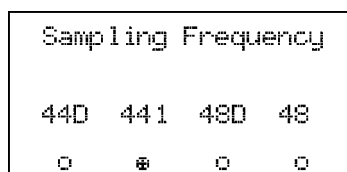

- Move the cursor to the corresponding item with the **[◀]** and **[▶]** keys or the control wheel, and confirm with **[ENT]** or **[▼]**. The cursor position is indicated with a flashing position sign (◻), the one currently selected with a cross-marked sign (⊠).

## 4.10.2 Overview

Menu Item	Display	Meaning	Parameters
<b>1</b>	<b>CONFIG</b>	<b>System configuration</b>	
11	S.FREQ	Sampling frequency	44.056, 44.1, 47.952, 48 kHz
12	S.WORD	Sample resolution	16, 20, 24, 24L bits
13	TC	Timecode format	24, 25, 29.97DF, 30, NONSTD
14	RECMODE	Record mode	stereo, mono
15	UNIT	Unit selection	unit1, unit2, unit3
16	DEFAULT	Configuration	
161	RECALL	Recall	User, Power on, Factory
162	STORE	Store current config to user setting	cancel, yes
17	REMOTE	Remote	local, remote
<b>2</b>	<b>REF &amp; INP</b>	<b>Reference &amp; input parameters</b>	
21	CLK SRC	Ref. clock source	int, dig, video
22	DIG REF	Digital reference	sync, wclock, audio
23	INPUT	Audio input	dig, analog, option
<b>3</b>	<b>AUDIO</b>	<b>Audio parameters</b>	
31	INP LEV	Analog input attenuator	inp1, inp2 (0...-14 dB)
32	OUT LEV	Analog output level	level (0...3)
33	DIG LEV	Digital playback level	channel1, channel2, (-12...+6 dB)
34	XFADE	Cross-fade time	(0...2000) ms
35	METER	Meter mode	peak, peak hold
<b>4</b>	<b>TRANSPORT</b>	<b>Transport &amp; display parameters</b>	
41	MAXSPD	Maximum wind speed	(2...30) × nominal speed
42	VARISPD	Play varispeed	off, on (±12.5%)
43	AUTO	Auto stop	off, on
44	PRE/POST	Pre-roll/post-roll	(2...40) s
45	FADER	Fader start1	disabled, enabled
46	REMAIN	Remaining time mode	auto, ind, take, seq
47	DISP RES	Display resolution	frames, ms
<b>5</b>	<b>DISK</b>	<b>Disk &amp; sequence utilities</b>	
51	SELECT	Select disk drive	(1...6)
52	SCSI	SCSI offline	yes, no
53	FORMAT	Format disk # ?	cancel, yes
54	CLEANUP	Cleanup disk # ?	cancel, yes
55	REN-SEQ	Renumber sequence ## )	cancel, yes
56	CLR-IND	Clear all indices of sequence	cancel, yes
57	DEL-FILE	Delete sound file --DESTRUCTIVE--	Seq #, take #, cancel, yes
<b>6</b>	<b>COPY</b>	<b>Copy utilities</b>	
61	WORK	Work copy seq ## to drv #	target, start
62	MASTER	Master copy seq ## to drv #	target, start
63	DISK	Copy disk # to drv #	target, start
64	XFER PAR	Transfer parameters	
641	SHAPING	Noise shaping	off, on
642	UPC/EAN	UPC/EAN code	1234 1234 12345
643	ISRC	ISRC code, track ##	abcde 1234567
644	CD MODE	CD copy mode	toc, multi, add, fix
645	DELAY	CD track delay	off, on
646	INDEX 0	Index 0 duration	off, on (2...5) s
65	FIXUP	Fixup disk # ? (for SADiE® exchange)	cancel, yes
<b>7</b>	<b>SERVICE</b>	<b>Service utilities</b>	
71	FORMAT	Format disk # ? (takes up to 40 min!)	cancel, yes
72	DATE	Date & time	day.month year hours:min



### 4.10.3 Menu 1, CONFIG (System Configuration)

#### 11 S. FREQ

##### Sampling Frequency

The sampling rates listed below may be selected for recording and playback. Please note that only one format is accepted per disk side. If another format is applied, an error message will appear.

- 44d 44.056 kHz
- 441 44.1 kHz
- 48d 47.952 kHz
- 48 48 kHz.

The 44d and 48d formats are provided for video drop-frame applications.

#### 12 S. WORD

##### Sample Resolution

Any of the following resolutions for an audio sample can be selected. It is valid for all subsequent recording sessions. Multiple formats within a sequence are allowed.

- 16 16 bit
- 20 20 bit
- 24 24 bit
- 24L 24 bit long.

For compatibility reasons, there are two different settings for 24 bit recording. Samples in standard 16, 20 and 24 bit format are packed (2, 2.5 and 3 bytes/sample) for maximum capacity. The 24L format stores a sample in 2 words (4 bytes/sample) for compatibility with third-party applications.

#### 13 TC

##### Timecode Format

The D424 provides SMPTE/EBU timecode at its TC OUT connector. The provided format can be changed at any time, it does not depend on the recorded information.

Once selected, the TC format is used for providing timecode and as display format.

- 24 24 fps
- 25 25 fps
- 29d 29.97 fps, drop-frame format
- 30 30 fps.

In addition to these standard formats, a special submenu provides two additional formats that can be used for non-standard configurations.

- 29 29.97 fps, non-drop format
- 30d 30 fps, drop-frame format.

#### 14 RECMODE

##### Channel configuration (“Record Mode”)

The following configurations are available:

- stereo New takes will be recorded in interleaved stereo mode. Both channels are stored in a single file. A single **[RDY]** command will enable both channels.
- mono New takes will be recorded in mono mode. The channel selected with the corresponding **[RDY]** key will be stored into a mono file.

When played back, a mono file will be routed to both output channels. Stereo and mono recordings can be combined in a sequence. Full editing functionality is provided.

- 15 UNIT** Unit Selection  
 The D424 Desktop Controller can drive up to 3 recorders. Each recorder must have its own unique address defined in this menu.  
 Select the address among unit1...unit3 (front panel only).
- 16 DEFAULT** Configuration settings  
 The D424 configuration settings can be stored into a user memory. If the settings were changed, they can be restored with a few keystrokes.  
**[SETUP] [1] [6] [2]** – Store the current settings (confirm with “yes”).  
**[SETUP] [1] [6] [1]** – Recall one of the following settings:

  - User Restore user settings
  - Power On Restore settings that were present when switching on the D424
  - Factory Restore factory defaults.
- 17 REMOTE** Remote Mode  
 The remote mode menu allows switching between:

  - local Local operation enabled (front panel or Desktop Controller)
  - remote Remote operation (serial remote port).  
 During remote operation, all local functions except SETUP are disabled.

4.10.4 Menu 2, REF & INP (Reference & Input Parameters)

- 21 CLK SRC** Ref Clock Source  
 Menu 21 provides the main clock references for the D424:

  - int Internal reference (quartz)
  - dig External digital reference (see menu 22)
  - video Composite video reference
- 22 DIG REF** Digital Reference  
 Menu 22 specifies the external digital reference signal:

  - sync AES-11 input
  - wclock Word clock input
  - audio Digital audio input

Mode	Status line indication	Setup menu 21	Setup menu 22	Reference input
Internal	INT	int	-	-
Video	VID	video	-	VIDEO
Digital, AES-11 ref.	DIG	dig	sync	AES/EBU SYNC
Digital, AES-3 audio input	DIG	dig	audio	AES/EBU IN
Digital, word clock	DIG	dig	wclock	WORDCKLOCK IN

If the currently selected reference is not available, the status line indication will flash.

- 23 INPUT** Audio Input  
 The D424 either records digital signals at the AES/EBU input, or analog signals at the line input (optional). With an appropriate adapter, the AES input will also accept SPDIF signals.

  - dig AES/EBU (or SPDIF) at AES IN
  - analog Analog at LINE IN (optional)
  - option Reserved for further I/O options

## 4.10.5 Menu 3, AUDIO (Audio Parameters)

**31 INP LEV**

## Analog Input Attenuation

The level of the analog inputs can be adjusted separately in 0.5 dB steps. The attenuation range is 0...–14 dB; with the standard I/O board configuration, the following sensitivities are achieved:

Attenuation in setup menu [dB]	0.0	–0.5	–1.0	...	–13.0	–13.5	–14.0
Input sensitivity [dBu full scale]	10.0	10.5	11.0	...	23.0	23.5	24.0

**32 OUT LEV**

## Analog Output Level

The level of the analog outputs can be set to one of 4 preset values. There is a common setting for both channels, the following levels are provided with the standard I/O board configuration.

Output level in setup menu	level 0	level 1	level 2	level 3
Output level [dBu full scale]	10	15	20	24

**33 DIG LEV**

## Digital Playback Level

When transferring digital audio signals to external devices, it might be necessary to adjust the overall playback level. The D424 provides a function to modify the playback level in the digital domain. There is a separate setting for each channel.

Range: –12...+6 dB, in 0.1 dB steps

**34 XFADE**

## Cross-fade Time

A cross-fade time can be specified. It will be applied to all subsequent recording and editing processes. Cross-fades are used in insert and auto recording modes as well as in cut, erase, and insert editing.

The cross-fade time is also applied to fade-in and fade-out processes in assemble recording and sequence editing.

It is possible to change the cross-fade parameter during the editing process. Please note that no further editing is allowed in fade or cross-fade areas.

When the cross-fade time is set to 0 ms, all corresponding processes will be performed without fade or cross-fade times.

Range: 0...2000 ms, in 1 ms steps

**35 METER**

## Meter Mode

The meters either display in standard peak or in peak hold mode.

peak  
peak hold

standard peak mode

peak hold mode; the peak value is reset with the **[PEAK RESET]** key, or with **[STOP]**.

#### 4.10.6 Menu 4, TRANSPORT (Transport & Display Parameters)

- 41 MAXSPD** Maximum Wind Speed  
 In SHTL mode, the end position of the control wheel refers to a variable maximum speed. The same speed is applied to the shortcut wind command **[PLAY+NEXT]** or **[PLAY+PREV]**.  
 Range: 2...30 × nominal speed, in multiples of the nominal speed.
- 42 VARISPD** Play Varispeed  
 If varispeed mode is switched on, playback with internal reference is performed with the corresponding varispeed. An indication with the currently selected speed will appear in the third line of the standard display.  
 off Varispeed mode is switched off  
 on Playback is performed with varispeed  
 Range: ±12.5 %, in 0.5 % steps.
- 43 AUTO** Auto Stop  
 When activated, the D424 will automatically stop at each new take begin.
- 44 PRE/POST** Pre-roll/Post-roll  
 When previewing edit processes or performing auto records, pre-roll and post-roll times are used. The D424 allows to specify these editing parameters separately.  
 Range: 2...40 s, in 1 s steps.
- 45 FADER** Fader Start  
 When the fader start operation is enabled, external fader start signals will generate the specified PLAY and STOP commands.  
 off Fader start mode is switched off  
 on Fader start mode is switched on.
- 46 REMAIN** Remaining Time Mode  
 The remaining time displayed in the 3rd line of the standard display refers to one of the following points:  
 auto depends on the take format, see **[TAKE FORMAT]** key:  
     TAKE – remaining time to end of take  
     TAKE/INDEX – remaining time to next index or take  
 ind remaining time to next index or to end of current take  
 take remaining time to end of current take  
 seq remaining time to end of sequence.
- 47 DISP RES** Display Resolution  
 All time information in the standard mode can be displayed either with ms or frame resolution. The frame format corresponds with the selected time-code format.  
 msec time information in hours, minutes, seconds and milliseconds  
 frames time information in hours, minutes, seconds and frames.

## 4.10.7 Menu 5, DISK (Disk &amp; Sequence Utilities)

**51 SELECT**

## Select Disk Drive

In the standard configuration, the D424 is working with its internal MO drive. Because the drive runs on a SCSI bus, the system can be expanded by connecting further devices. The D424 currently supports the 2.6 GB MO drive and the CD writers.

In multiple drive configurations, a “current device” is selected. All system operations are performed with this current device.



All available disk drives will be listed with the type (MO or CD) in the order of the SCSI address (1...6). The one currently selected is cross-marked.

Default addresses: 1 for internal drive, and 2 for D741 CD recorder.

For changing the current disk, move to the new drive with the cursor keys, and confirm the new selection.

**52 SCSI**

## SCSI Offline

In SCSI offline mode, a D424 is configured as a single MO drive; all internal functions are disabled. As a slave, it can be connected to any SCSI-based controller that supports the 2.6 GB ISO drive, like a master D424 or a suitable digital audio workstation.

- yes Select SCSI offline mode. D424 is operated from an external controller.
- no Select standard online operation.

**53 FORMAT**

## Format Disk

The inserted disk will be high-level formatted. All data will be lost, the necessary DOS file structure is stored onto the disk. The process takes a few seconds.

The FORMAT DISK utility is used for initializing a disk and to make it ready for recording. After inserting a new, unformatted disk, the D424 automatically switches to this menu.

High-level formatting is also the fastest way to “clean” a recorded disk and create a new, empty disk.

- cancel return to the previous menu page
- yes starts the formatting process. A “processing” message will be shown during the formatting process, which takes only a few seconds.

**54 CLEANUP**

## Cleanup Disk

The CLEANUP process removes all sound files that are not used by any of the sequences. It is performed to remove all temporary sound files that were created during a session. All sequences and the required audio files remain unchanged.

- cancel Return to the previous menu page
  - yes Start the CLEANUP process. A “processing” message will be shown during the process.
- The CLEANUP process can reassign space for recording. If a sequence has been recorded with a single recording session, a CLEANUP cannot have any effect – only complete sound files will be deleted.

**55 REN-SEQ**

## Renumber Sequence

During editing, take numbers stay with the corresponding audio information, whereas indices always are renumbered to have an ascending order. At the end of a production, it might be helpful to reassign take numbers to the current sequence.

The utility renumbers the takes in ascending and contiguous order, beginning with "1" and according to the current sequence list.

cancel Return to the previous menu page

yes Start the RENUMBER process. A "processing" message will be shown during the process.

The take and index markers as well as the absolute time and timecode marks remain unchanged with respect to their audio position.

**56 CLR-IND**

## Clear All Indices of sequence

If indices were used for editing purposes only, they can be removed at the end of a production. CLEAR INDICES removes all index markers of the current sequence.

cancel Return to the previous menu page

yes Start the CLEAR INDICES process. A "processing" message will be shown during the process.

**57 DEL-FILE**

## Delete Sound file

Instead of CLEANUP (which removes all sound files no more in use), the DELETE SOUND FILE utility allows to delete single sound files.

Because of the non-destructive editing technique, it is the only way to delete single sound files; all other operations only affect the edit decision lists, i.e. sequence files.

Sound files are addressed by means of their take number in the sequence 0, which is a "table of contents" of the currently inserted disk.

seq-0; take ## Enter the take number to be deleted from the "table of contents"

cancel Return to the previous menu page

yes Delete the selected sound file.

For a correct identification, create a new temporary sequence, insert all takes from sequence 0 with [SEQ] [▶] [TARGET+INSERT] [SEQ], and look for the take to be deleted. Then select the DEL-FILE utility and delete the corresponding take of sequence 0.

## 4.10.8 Menu 6, COPY (Copy Utilities)

All COPY utilities will transfer information from the currently inserted disk to a destination drive connected to the SCSI bus.

target Select the target drive to which the data will be copied.

start Start the copy process.

```

Work Copy
seq 04 to Drv 1

target start

```

**The copy menu page lists the currently selected source data and the target drive**

```

#####
processing /

```

**During the copy process, a bar in the top line reports on the progress**

**61 WORK****Work Copy**

will make a copy of the current sequence onto the target MO disk. A new, identical sequence will be created, including all sequence information like take and index markers. All sound files used by the sequence will be transferred as well.

Work copy is helpful for making backup copies. The new sequence not only contains the currently used audio information, but also the complete audio sound files.

**62 MASTER****Master Copy**

will make a copy of the current sequence to the target MO disk, as an exact copy of the source sequence, including track and index information. The audio information will be merged into a new single sound file.

With MASTER COPY a new file is recorded. Some of the general recording parameters are considered. Please check for the correct format (e.g. word length)

When performing a MASTER COPY to or from a CD writer, some special rules apply:

**Writing CDs**

In addition to the audio files, the essential PQ data will be transferred as well. This includes take and index markers, UPC/EAN and ISRC codes. See menu 64 for more details.

**Copying CDs to the D424**

When selecting the CD writer as source drive and the D424 as target, single tracks (add mode) or complete CDs (toc mode) can be transferred in a new sequence on the MO disk. Each track is copied to a separate sound file, the sequence also includes the track numbers.

**63 DISK****Disk Copy**

will copy the complete disk. The target disk has to be empty. Reformat it if necessary (with setup utility 53).

**64 XFER PAR**

Transfer Parameters

The following parameters (641...646) apply to MASTER COPY transfers.

**641 SHAPING**

Noise Shaping

```

Noise Shaping

off      on
*        o
    
```

For making best use of high quality recordings in 20 or 24 bit resolution, it is possible to apply the noise shaping algorithm on audio information transferred to 16 bit media.

If set to OFF, audio data will be truncated to 16 bits.

**642 UPC/EAN**

UPC/EAN Code (CD transfer only)

```

UPC/EAN Code

-----
    
```

Catalogue number for CDs (13 digits).

The indicated number is read from the inserted CD, modifications are only possible as long as no code was programmed yet (code is 0).

**643 ISRC**

ISR Code (CD transfer only)

```

ISR Code

track
03 -----
    
```

International Standard Recording Code (5 alphanumeric and 7 numeric digits) including country and owner identification, recording year, and serial number.

There is one ISRC code for each take. If cleared, no ISRC code is recorded.

**644 CD MODE**

CD Copy Mode (CD transfer only)

```

CD Copy Mode

toc  multi  add  fix
o    o     *   o
    
```

- TOC disc-at-once transfer
- MULTI like TOC, multi-session expandable
- ADD adding current sequence without table of contents
- FIX CD finalizing process only (no data)



**645 DELAY**

CD Track Delay (CD transfer only)

CD Track Delay	
off	on
o	*

If the CD track delay is switched on, the audio information of a new track is delayed 100 ms after the start of a new index 1. This allows consumer CD players to start up and de-mute in time.

**646 INDEX 0**

Index 0 Duration (CD transfer only)

Index 0 Duration		
off	on	
*	o	2 sec

At the beginning of a new track, a pause with index 0 may be inserted, by defining a duration between 2...5 seconds.

When the duration is set to OFF, no pause is inserted.

**65 FIXUP**

Fixup Disk

The FIXUP utility creates the necessary files required for SADiE® compatibility. The D424 sequence file is replaced by an interchange file that can be interpreted by SADiE®. Remove the disk after the fix-up process.

If a SADiE® compatible disk is reinserted to the D424, all found interchange files will again be replaced by new, corresponding D424 sequence files.

## 4.10.9 Menu 7, SERVICE (Service Utilities)

**71 FORMAT**

Format Disk

New disks are preformatted from the manufacturer. This process is called “low-level formatting” and is usually not necessary anymore. It is only useful after having cleaned a disk that had numerous defective blocks. Low-level formatting will then recheck every bit on the disk on validity, which takes up to 40 minutes.

**72 DATE**

Date &amp; Time

The entered date and time will be stored to a battery-buffered clock circuit. All recorded files will be marked with their origin or modification dates.

## 4.11 Desktop Controller

The Desktop Controller is an ergonomic alternative to the D424's standard front panel. It can be placed on a desk or a mixing console, and has a standard size to be built into a console. See fold-out page, section 2. In addition to the new design and the full front panel functionality, it provides some operation enhancements and is capable of controlling up to three recorders.

### 4.11.1 Configuration

The controller is connected to the master unit with a single controller cable including the power supply as well as an audio monitoring signal for the headphones output (both hard-wired to the master unit) as well as the communication lines.

**Note:** The headphones output can monitor the audio signal of the first unit only. Two additional units can be connected in a daisy-chain configuration with two additional sync cables; the last one must be equipped with a termination connector.

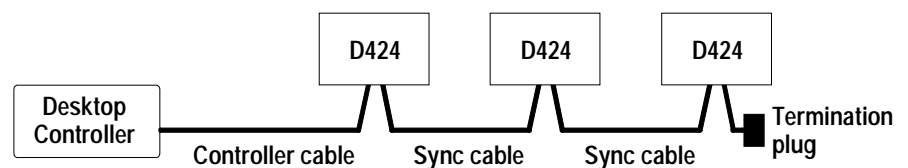

Each recorder connected to the Desktop Controller has its own unique address that can be assigned with setup menu 15.

### 4.11.2 Operation

#### Selecting a Recorder:

As long as no recorder is selected, the controller is in idle mode, showing a “not assigned” message. All connected recorders run locally.

The Controller can address one recorder at a time by selecting the corresponding key [UNIT1], [UNIT2], or [UNIT3]. The selected recorder will switch to remote mode and show “\*\* serial remote \*\*”, the Controller will load the current device data and be ready for operation

A remote connection is cancelled by deselecting the active unit (pressing the same [UNITx] key again) or by selecting another one.

#### Operation Enhancements:

##### Direct Access to Input Level

The setup menu for the calibration of the analog input attenuation can be accessed directly. Simply press and hold one of the new volume keys [VOL1] or [VOL2] and modify the parameters with the control wheel or with the numerical keyboard.

##### Set Cue Mode Sensitivity

With the [SLOW] key near the control wheel, the sensitivity of the cue operation can be adapted. In SLOW mode, the same wheel movement causes only a third of the standard distance.

##### Improved Key Assignment

The INSTANT LOCK function is assigned to a separate key.

The [LOC] key is part of the main transport section with large push-buttons. It is closer to the main destination keys ([IN], [OUT], [0...9]).

The [TAKE FORMAT] and [TIME FORMAT] keys are now separate and no longer shared with the cursor functions.

## 4.12 Parallel Port and Fader Start Operation

A parallel remote port is provided for basic transport control and status indication, a fader start circuit, and power supply voltages for external circuits.

The port is always active. Therefore, a parallel controller may be operated simultaneously with the front panel or a serial controller.

### 4.12.1 Specifications

**Connector:** D-type, 15 pin female

**Pin Assignment:**

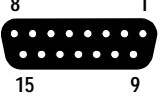
	Pin	Signal	Function
	1	B_TAKE	Take pulse
	2	B_INDEX	Index pulse
	3	B_PLAY	Play tally
	4	S_STOP	Stop command
	5	S_PLAY	Play command
	6	S_PLOC	Ploc command
	7	FADER1	Fader start input 1
	8	GND	Ground
	9	B_STOP	Stop tally
	10	B_READY	D424 ready
	11	VCC	Supply voltage, switchable 5/24 V
	12	S_PREV	Previous command
	13	S_NEXT	Next command
	14	FADER2	Fader start input 2
	15	KEY	Key

### 4.12.2 Signal Description

Signal	Description
VCC	Supply voltage (5 V <sub>DC</sub> , may be switched to 24 V <sub>DC</sub> )
GND	Signal ground
S_STOP	Stop command
S_PLAY	Play command
S_PLOC	PlayLoc command (locate to the last play position)
S_PREV	Previous command (skip to the previous take or index marker)
S_NEXT	Next command (skip to the next take or index marker)
B_INDEX	Indicates new index marker. A pulse signal is generated when an index marker is passed in play mode.
B_TAKE	Indicates new take marker. A pulse signal is generated when a take marker is passed in play mode.
B_STOP	Stop tally, active when D424 is in Stop mode
B_PLAY	Play tally, active when D424 is in Play mode
B_READY	Fader Ready status, D424 is ready for fader start
FADER1, FADER2	Fader start contact, see following paragraph
<i>All inputs are opto-coupler inputs, negative-edge triggered. Use a switch or an open collector to signal ground as a driver.</i>	
<i>All outputs are open-collector outputs. A static signal is active low, a pulse signal is a negative pulse with active leading edge.</i>	

### 4.12.3 Fader Start

The D424 provides an opto-coupler input (with internal bridge rectifier and 20 mA current sink) for fader start operation.

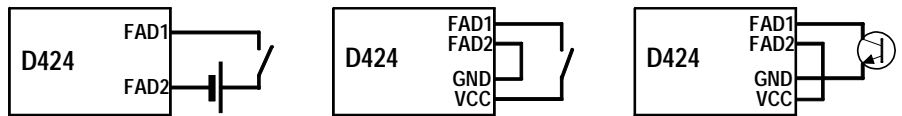

**Fader Start Contact** The fader start input is activated by applying a voltage of 5...24 VDC. Connect either an external voltage source (left), use the internal supply voltage (center), or pull to ground with a switch or an open collector (right).

**Fader Operation** The following conditions are necessary to trigger a fader start:

- Fader start operation is enabled with setup menu 45.
- The D424 is ready for playback, i.e. a disk with a playable sequence is inserted.

If the above conditions are met, the fader ready signal (GPI pin10) is active, indicating that fader start signals will be accepted.

Every transition of the fader start signal from inactive to active (applying a voltage or closing the contact) will generate a PLAY command; each transition from active to inactive (release the contact or removing the voltage) will cause a STOP.

During fader play operation, the local keyboard is disabled. The D424 will stop at the end of a sequence, or at the end of a take with activated AutoStop function.

## 4.13 Serial Remote Operation

---

The serial remote control specification for the D424 is intended for applications where the D424 is controlled by equipment using the SONY RS-422 standard. The D424 provides a basic subset of the complete functionality.

In addition to the standard commands, an extension was made to allow addressing of takes and indices instead of timecode and tape counter parameters only.

### 4.13.1 Command List

---

Please refer to the appendix (chapter 9) for more details.

## 5 TROUBLESHOOTING

### 5.1 Error Messages

Operation and configuration errors:	Problem:	Solution:
"CD not suitable"	Inserted disc cannot be used for selected transfer	Insert empty CD-R for TOC transfer, or not yet finalized CD-R for ADD transfer
"Check take distance"	CD transfer tried with at least 1 take below 4 s audio	Modify corresponding take to more than 4 s
"Clk.RefDk DiskH" "Clk.RefDk DiskHD" "Clk.RefHk DiskD" "Clk.RefHk DiskDD"	Format of external reference signal (Clk.Ref) does not correspond to sampling rate (Disk) H = 48, HD = 48drop, D = 44.1, DD = 44.056	Select correct configuration
"Cmd not allowed"	Command could not be accepted temporarily	Some system utilities and configuration settings disabled in play and recording modes, stop D424 first
"Disk not empty"	When trying to do DISK COPY, target disk was found not empty	Reformat target disk before doing a DISK COPY
"Disk performance"	1.2/1.3 GB disk not capable of performing insert recording with 29/24 bit resolution	Select 16 bit resolution or use 2.3/2.6 GB Disk
"Disk write protected"	Disk protected with "write protect" tab	Move tab to "rec enable" position
"Drive is busy"	SCSI operation failed because corresponding device is in use	Stop D424 before switching SCSI devices
"Drive not mounted"	D741 CD drive not ready for transfer	<ul style="list-style-type: none"> <li>• Insert appropriate CD-R</li> <li>• Check for correct SCSI wiring</li> </ul>
"Drive not supported"	SCSI drive has been connected to a D424 currently not supported	Remove SCSI device
"Editing in fade area"	Editing in fade area not allowed	Move edit points, or modify previously made edit that generates particular fade area
"Emphasis mismatch"	Attempt to add a take with an emphasis status different from the previously recorded sequence	All takes of a sequence should be recorded with the same emphasis status.
"Invalid edit points"	Edit points IN and OUT beyond the sequence limits, or IN > OUT	Set correct edit points
"Invalid rec points"	Edit points IN and OUT for AutoRecord mode beyond the sequence limits, or IN > OUT	Set correct edit points
"ISRC error"	ISRC entry not complete, or corresponding take information corrupted	Check data
"Last rec nr reached"	Attempt to record more than 99 sound files	Try to remove unused audio files with a Cleanup
"Low diskcopy space"	Current sequence (TOC mode) or take (ADD) longer than available space on CD-R	Adjust sequence length to disc, or use new disc
"Max tk/lx nr reached"	Attempt to create take or index number greater than maximum (99)	Remove old unnecessary markers and renumber sequence
"Mismatch TC format"	Timecode format at TC input not corresponding to internal TC format	Select correct TC format
"No record space left"	No space left for new recording session	Try to remove unused audio files with CLEANUP
"Nothing to UNDO"	Last edit process cannot be undone, because of: <ul style="list-style-type: none"> <li>• Sequence processes since the last edit</li> <li>• Not in edit mode</li> </ul>	<ul style="list-style-type: none"> <li>• -</li> <li>• Switch to edit mode with SOURCE/TARGET</li> </ul>
"One Smprate on disk"	Attempt to switch sampling rate within recorded disk	Only one sampling rate allowed per disk side – reformat disk to change sampling rate
"Reg val out of range"	Locate was tried with corresponding register contents beyond current sequence range	Modify register
"Smprate not 44.1kHz"	CD transfer was tried, but source sequence has not 44.1 kHz sampling rate	CD transfers only possible with 44.1 kHz sampling rate
"UPC error"	UPC entry invalid, or inserted CD-R already has valid UPC code	Check data or replace disc
"Wrong copy params"	Copy parameter is not valid for current copy configuration	Check copy target and parameters
"Wrong SCSI id select"	Copy process cannot be performed with currently selected target drive (e.g. work copy to CD-R)	Check copy target and parameters

Operation and configuration errors (cont.):	Problem:	Solution:
"XFadetime too long"	Two fade areas overlapping	Reduce cross-fade time
"Sample slip"	Digital audio input not synchronous with system clock	Check synchronization of external source with D424

Hardware errors:	Problem:	Solution:
"0A: Restart device" "0D: Restart device" "6E: Restart device" "7F: Restart device"	Fatal internal errors	Switch off system and retry Contact dealer
"BD: Restart system"	Currently selected drive reporting fatal HW error	Switch off system and retry Replace drive if necessary
"C5: Restart device"	General SCSI error encountered	Switch off system Check SCSI cabling and retry
"D0: Restart device"	CD transfer failed due to D741 initialization error	Switch off system and retry
"D1: Restart device"	D741 timeout occurred after data transfer or after CD finalizing process	Switch off system and restart; D741 should then be able to read CD
"RTC battery is low"	Battery voltage of parameter RAM low, default parameters loaded	Check parameters; if error occurs again, contact dealer for battery replacement

Medium errors:	Problem:	Solution:
"78: Restart device"	CD transfer failed (write error or manual interrupt)	Restart system, try with new CD-R
"8A: Restart device" "Out of realtime"	Disk-related SCSI error encountered during transfer	<ul style="list-style-type: none"> <li>• Check disk for defective blocks</li> <li>• Save data to external device as soon as possible, clean and low-level format the disk</li> </ul>
"BC: Low format disk"	MO drive reports medium error	Switch off system, retry; save data to external device ASAP, clean and low-level format the disk; if errors remain after formatting, replace disk
"BE: Critical medium"	Information on current disk incorrect, had to be repaired, or SCSI bus is not connected or not correctly terminated	see above
"Corrupt record pool"	Incorrect system files found	Switch off system, retry; save data to external device ASAP, clean and low-level format the disk
"Disk corrupted"	Incorrect application files found	see above
"Last record failed"	Temporary record file found to be incorrect when trying to create corresponding system entries	Contact dealer for trying to repair the disk on system level
Warning: Defect blocks"	Inserted disk already has a considerable number of defective blocks	Do not start new, important sessions with such disks; if the number is increasing rapidly, clean the disk and try to save the data as soon as possible; refer to chapter 1.2.4 for more details

## 5.2 Modifying the D424 SCSI Address

If connecting several D424 MO recorders with a SCSI cable, the address of additional units has to be adapted.

SCSI address	Pin 1	Pin 2	Pin 3
0	n.a.	n.a.	n.a.
1			•
2		•	
3		•	•
4	•		
5	•		•
6	•	•	
SCSI address setting for 2.6 GB ISO drive; • = jumper inserted			

For connecting two units, change the address of the second unit from the default value 1 to 4. For that purpose, simply move the address jumper at the rear of the drive from position 3 to position 1, as shown below.

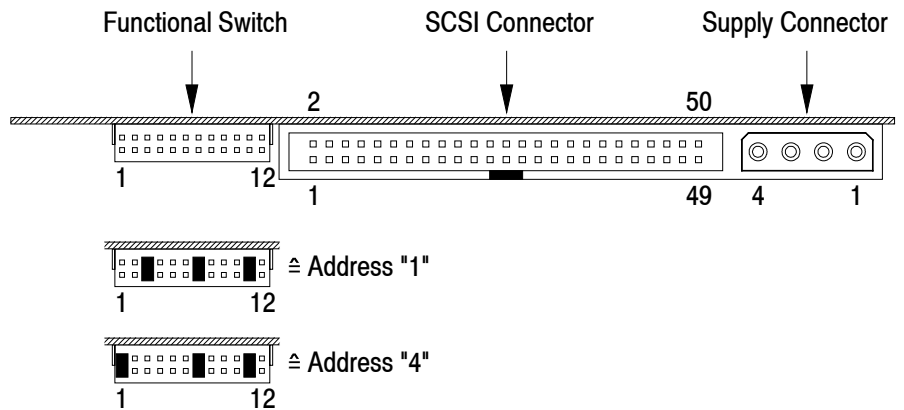

*This modification may be performed by qualified personnel only. Please consider the safety and EMC section at the beginning of the operation manual.*

1. Disconnect the unit from the mains supply, remove the top cover.
2. Set the address with the jumper(s) on the “functional switch” at the rear side of the drive.
3. Re-install the cover and reconnect the unit to the mains supply.



---

## 6 D424 – CIRCUITS, JUMPER SETTING

---

### 6.1 Motherboard

1.866.120

The Motherboard is designed to carry assemblies, as the Core and A/D-D/A converters. For audio interfaces, two slots are available.

It contains the following modules:

- Clock generation (internal/external reference) with input and output drivers (word clock with selectable termination)
- Time code reader and generator with input and output drivers and connectors
- Digital AES/EBU inputs and outputs with drivers and connectors
- Simple D/A converter for monitoring purposes for the internal phones jack and the one on the Desktop Controller
- Power supply
- General Purpose parallel interface.

These modules are controlled via the 68360 processor's data bus.

---

#### 6.1.1 Clock Regeneration

---

The clock regeneration consists of three parts:

- The Video PLL (ICs 34, 36, 39, 42) has a VCXO (voltage-controlled quartz oscillator) with a narrow capture range because the reference frequency on IC39/Pin3 is very low. By selecting the control frequency of the VCXO (IC36/Pin1) also the internal reference frequency is derived from the VCXO. It can be adjusted with trimmer potentiometer RA2 (19.2 MHz on IC36 or sampling rate on the word clock output). If the signal ILOCK (IC42/Pin19) is low, the Video PLL is locked.
- The main PLL (ICs 59, 62, 66) receives the VCXO signal, divided by 1000 or 1001, as a reference on IC62/Pin3, or a word clock signal directly from the WCLK input, from the AES Sync input (IC1), or from the AES audio input (IC5). If the signal MLOCK (IC59/Pin20) is low, the main PLL is locked.
- The TC PLL (ICs 40, 44) generates the bit clock frequency of the TC generator (adjusted frame rate  $\times$  80) from a reference frequency derived from the sampling rate (1600 Hz, IC40/Pin3). The VCO (IC40/Pin4) is always clocking with 4.8 MHz. If the main PLL is not locked or the Power Down signal (IC59/Pin37) is low, the audio signal is muted.

*(Please refer to the two tables on the following page.)*

Synchronization Setting						
FS	INTE	DRP	WCL	AES	VAREG	Sampling Rate
0	1	0	0	x	768	48 kHz internal
0	1	1	0	x	768	48 kHz drop-frame internal
1	1	0	0	x	872	44.1 kHz internal
1	1	1	0	x	872	44.1 kHz drop-frame internal
0	1	0	0	x	2048-1280 (1+A)	48 kHz internal w. Varispeed A*
1	1	0	0	x	2048-1176 (1+A)	44.1 kHz int. w. Varispeed A*
0	0	x	1	0	x	48 kHz external (WCLK)
1	0	x	1	0	x	44.1 kHz external (WCLK)
0	0	x	1	1	x	48 kHz external (AES)
1	0	x	1	1	x	44.1 kHz external (AES)
0	0	0	0	x	768	48 kHz external (Video)
0	0	1	0	x	768	48 kHz drop-frame ext. (Video)
1	0	0	0	x	872	44.1 kHz external (Video)
1	0	1	0	x	872	44.1 kHz drop-frame ext. (Video)

\* A range: -0.125...+

Video Composite Sync/TC Generator		
<b>VAUT</b>		
0	PLL divider defined by VR1, VR0	
1	PLL divider automatically selected	
<b>VR1</b>	<b>VR0</b>	Frame Rate on Sync Input/TC Generator Frame Rate
0	0	30 Hz
0	1	30 Hz drop-frame
1	0	25 Hz
<b>FR1</b>	<b>FR0</b>	Computed Frame Rate/TC Generator Frame Rate
0	0	30 Hz
0	1	30 Hz drop-frame
1	0	25 Hz
1	1	24 Hz
Frequency Measurement for Word Clock or AES/EBU Inputs		
<b>R1</b>	<b>R0</b>	
0	0	out of range
0	1	48 kHz ( $46 \text{ kHz} < f_s < (48 \text{ kHz} + 13\%)$ )
1	0	44.1 kHz ( $(44.1 \text{ kHz} + 13\%) < f_s < 46 \text{ kHz}$ )
1	1	not used

### 6.1.2 Time Code

For the handling of the SMPTE time code the TC reader (IC30) and the TC generator (IC29), and for exact synchronization with the audio signal the controller (IC20) are responsible.

### 6.1.3 Audio

The audio TDM bus is linked to the core via the bi-directional register (IC28). With the controller (IC2) and the Dual Ported RAM (IC11) the audio data are buffered and converted to the appropriate format for the monitor D/A converter (IC17), for the AES/EBU receiver (IC5) and the AES/EBU transmitters (IC4).

#### 6.1.4 Desktop Controller

The Desktop Controller 68HC11 (IC61) communicates via the serial SCI interface with the main processor. It is responsible for the keyboard scanning and the different displays. It boots with an internal boot routine and subsequently – if required – loads the main program from the 68368 via the SCSI interface to the RAM which is buffered by a high-capacity electrolytic.

#### 6.1.5 Power Supply

In order to bridge comparatively long power interruptions two large capacitors (C119, 141) are connected in parallel to the 24 VDC. From this voltage the +5 V for the logic, the +12 V for the MO drive and  $\pm 14$  V for the analog circuits are derived. The  $\pm 14$  V are electrically separated from the digital supply. These switched-mode regulators are clocked with twice the sampling rate. The switching thresholds at the 24 V input for the power-down signal and the power-on threshold are detected by IC18. RA1 is used to adjust the  $\pm 14$  V supply.

For the fluorescent display, 4 V<sub>AC</sub> and 50 V<sub>DC</sub> are generated by T10. The different auxiliary voltages for A/D and D/A converters etc. are regulated on-board on the corresponding assemblies.

#### 6.1.6 Jumper and DIP Switch Settings

<b>1. Supply Voltage on the Parallel Remote Connector (Pin11):</b>		
24 V/max. 300 mA if JP1 and JP2 are linked		
5 V/max. 700 mA if JP2 and JP3 are linked		
<b>2. Supply Voltage on the Serial Remote Connector (Pin9):</b>		
24 V if JP4 and JP5 are linked		
n.c. if JP5 and JP6 are linked		
<b>3. DIP Switch (DS1)</b>		
1	off	Spare
2	off	Spare
3	on	Spare
4	on	Baud rate (off position used for factory tests only)

## 6.2 Core

1.866.130

The Core fulfills the following tasks:

- Handling of the MO drive
- Data transfer between the different audio data interfaces, as Ethernet, SCSI (MO drive), TDM bus
- Processing the control interfaces (Desktop Controller, Front Panel, Sony 9-pin)

The digital signal processor (DSP) on the Core is responsible for cross fades, computation of output levels, etc.

The main processor 68360 is the CPU of the MO recorder. It has several serial interfaces for the communication with the front processor, the remotes, the monitoring interface (with IC107), the Ethernet interface etc. The software is stored in the two Flash memories (IC104, 105). Communication with the MO drive is done via the SCSI controller (IC504). The audio data are subdivided by the "Word builder" (IC601), depending on the audio word length and buffered in the SIMM-DRAM (IC402) supported by the Controllers (IC701). The link to the Motherboard is effected by the bi-directional register (IC404) and the Dual Ported RAM (IC403) with the Controller (IC401). The SCSI bus is actively terminated by IC503.

### 6.2.1 Jumper and DIP Switch Settings

The address for the Desktop Controller is normally set in the Setup menu. On units without a front panel operating surface this has to be done with DS1 (on from SW version 1.2).

The controller interface can be selected for operation with the Studer Desktop Controller or with a customer-specific remote control; for this purpose DIP switch No. 1 of DS1 is provided.

DS1:				
4	3	2	1	
<b>Controller Port Operation Mode:</b>				
off	x	x	x	Operation with Studer Controller/31.25 kBd
on	x	x	x	Operation with Special Controller/38.4 kBd
<b>Controller Address:</b>				
x	x	off	off	selectable on front panel
x	x	off	on	Address 1
x	x	on	off	Address 2
x	x	on	on	Address 3

J401 and J403 are always inserted.

All remaining jumpers remain open. They are used for matching to the DP RAM size (J405 and J407), as programming connectors for IC 601/701 (P601...P610 and P701...P710), as a Debug connector for the DSP (IC302) (P301...310) and the processor (IC102) (P111...120), or as monitoring interface (P101...P103).

## 6.3 A/D-D/A Board

1.866.140

The A/D-D/A Board contains two A/D and D/A channels each. The converters are connected to the TDM bus via the Controller (IC29) and the bi-directional Register (IC25). IC33 is a temporary audio data buffer.

The input sensitivity can be adjusted individually per channel in steps of 0.5 dB in the Setup menu; the setting range is +10...+24 dBu for full modulation. The output level can be set in four steps in the Setup menu as well (+10, +15, +20, and +24 dBu for full modulation).

The A/D-D/A Board is controlled via the SPI bus (ICs 28, 30, 31).

### 6.3.1 Level Setting

Adjust in the Setup menu the input attenuator to 0 dB, the output level to "0". Feed an input signal of 1 kHz/+10 dBu to the analog inputs. Adjust trimmer potentiometers RA1 (CH1) and RA2 (CH2) so that the Clip LEDs of the Peak Meter just are off. Adjust the output level with RA3 (CH1) and RA4 (CH2) to +10 dBu. Then enter the desired input sensitivity and output level in the Setup menu.

Should an output level differing from the four given values be desired, it can be adjusted as follows:

7 to 12 dBu:	Level "0"
12 to 17 dBu:	Level "1"
17 to 22 dBu:	Level "2"
22 to 26 dBu:	Level "3"

Afterwards, the exact value can be set with the trimmer potentiometers RA3 and RA4.

## 6.4 Keyboard

1.866.160

Keyboard and display is controlled by the front processor (68HC11) on the Motherboard. Keyboard and LED matrix are multiplexed by IC1.

## 6.5 Display Board

1.866.150

The vacuum fluorescence display (VFD, 4 × 20 digits) is driven from a mask-programmed 80C52 (IC11) via high-voltage drivers (IC 1...10). It is connected to the front processor on the Motherboard via a parallel interface.

## 6.6 Connector Pin Assignments

Sony 9-pin (D-type, female):		
1	CHASSIS	
6	TCOMMON	GND
2	IRS422T	TX-
7	RS422T	TX+
3	RS422R	RX+
8	IRS422R	RX-
4	RCOMMON	GND
9	CHASSIS	
5	+24 V	Supply (only if JP4 and JP5 connected on mother board)

Parallel Remote (D-type, 15-pin, female):		
1	PHR-	Phones right -
9	PHR+	Phones right +
2	PHL-	Phones left -
10	PHL+	Phones left +
3	AGND	Analog GND
11	+24 V	Supply Desktop Controller
4	REMT	Rem bus TX +
12	IREMT	Rem bus TX -
5	REMR	Rem bus RX +
13	IREMR	Rem bus RX -
6	STSTR	Start signal +
14	ISTSTR	Start signal -
7	SYNCBUS	Sync bus +
15	ISYNCBUS	Sync bus -
8	DGND	Digital GND

General Purpose Parallel Interface (D-type, 15-pin, female):		
1	B_TAKE	Pulse indicates take marker
9	B_STOP	Stop acknowledgement
2	B_INDEX	Pulse indicates index marker
10	B_READY	D424 ready acknowledgement
3	B_PLAY	Play acknowledgement
11	VCC	Supply (24 V if JP1 and JP2 connected; 5 V if JP2 and JP3 connected)
4	S_STOP	Stop command
12	S_PREV	Previous command
5	S_PLAY	Play command
13	S_NEXT	Next command
6	S_PLOC	Locate command (to last play start position)
14	FADER2	Fader start input
7	FADER1	Fader start input
15	KEY	Key
8	GND	0 V

## 7 DESKTOP CONTROLLER – CIRCUITS, JUMPER SETTING

### 7.1 Remote Keyboard

1.866.510

The Remote Keyboard is connected to the Remote Control PCB via a flat cable; it houses all the keys, the LED indicators, and the peak meter. IC3 is controlled via the 68HC11's data bus on the Remote Control PCB, and it drives the  $15 \times 8$  LED matrix by time multiplex. The key scanning is performed by IC3, too. If a key is pressed or released, a "KEYIR" interrupt is sent to the Controller.

The rotary encoder S1 delivers two square-wave signals with a  $90^\circ$  phase shift (de-bounced by IC1) from which the pulse count as well as the direction of rotation can be recognized.

### 7.2 Remote Control PCB

1.866.520

The 68HC11 Controller (IC13) communicates via an RS232 interface with the MO Recorder's main processor. It performs the keyboard scanning and the data transmission to the Display PCB, and drives the LED indicators and the peak meter display.

It boots with its internal boot routine and loads afterwards, if required, the 68360's main software into the RAM. This RAM is buffered with a High-Cap capacitor, so the software is retained for several days.

IC14 is used for generating a defined reset.

The logic circuits are supplied by a switching regulator (IC5). IC1 generates 20 VDC for the analog circuits, while the free-running oscillator (with T1, Q2, and Q4) produces the anode voltage VGG and the heating voltages FIL1/2 for the VF display.

The monitor amplifier receives its input signal from two balanced inputs, its level can be adjusted with IC6.

The DIP switches (S1) are set as follows:

DS1:		
1	off	Spare
2	off	Spare
3	off	Spare
4	on	Baud rate (off position used for factory tests only)

### 7.3 Display PCB

1.866.150

The Display PCB is plugged directly to the Remote Control PCB. The display data are sent by the 68HC11 controller on the Remote Control PCB via the data bus into an octal latch. From this latch the data are read out by a mask-programmed 80C52 which converts them for the  $5 \times 7$  dot matrix VF display with four lines and 20 characters each. The VFD is controlled by high-voltage drivers in time multiplex.

## 8 CIRCUIT DIAGRAMS

---

### Board Locations and Interconnections

#### Block Diagram Mother Board

Mother Board ..... 1.866.120

#### Block Diagram SCSI Core

SCSI Core ..... 1.866.130

SCSI Core ..... 1.866.131

#### Block Diagram Analog Input/Output

Analog Input/Output ..... 1.866.140

#### Block Diagram Display Board

Display Board ..... 1.866.150

#### Block Diagram Keyboard

Keyboard ..... 1.866.160

Clock Input/Output ..... 1.866.170

Phones Board ..... 1.865.160

### Optional Desktop Controller

Display Board (*see 1.866.150 above*)

Remote Keyboard ..... 1.866.510

Remote Control ..... 1.866.520



Board locations and Interconnections

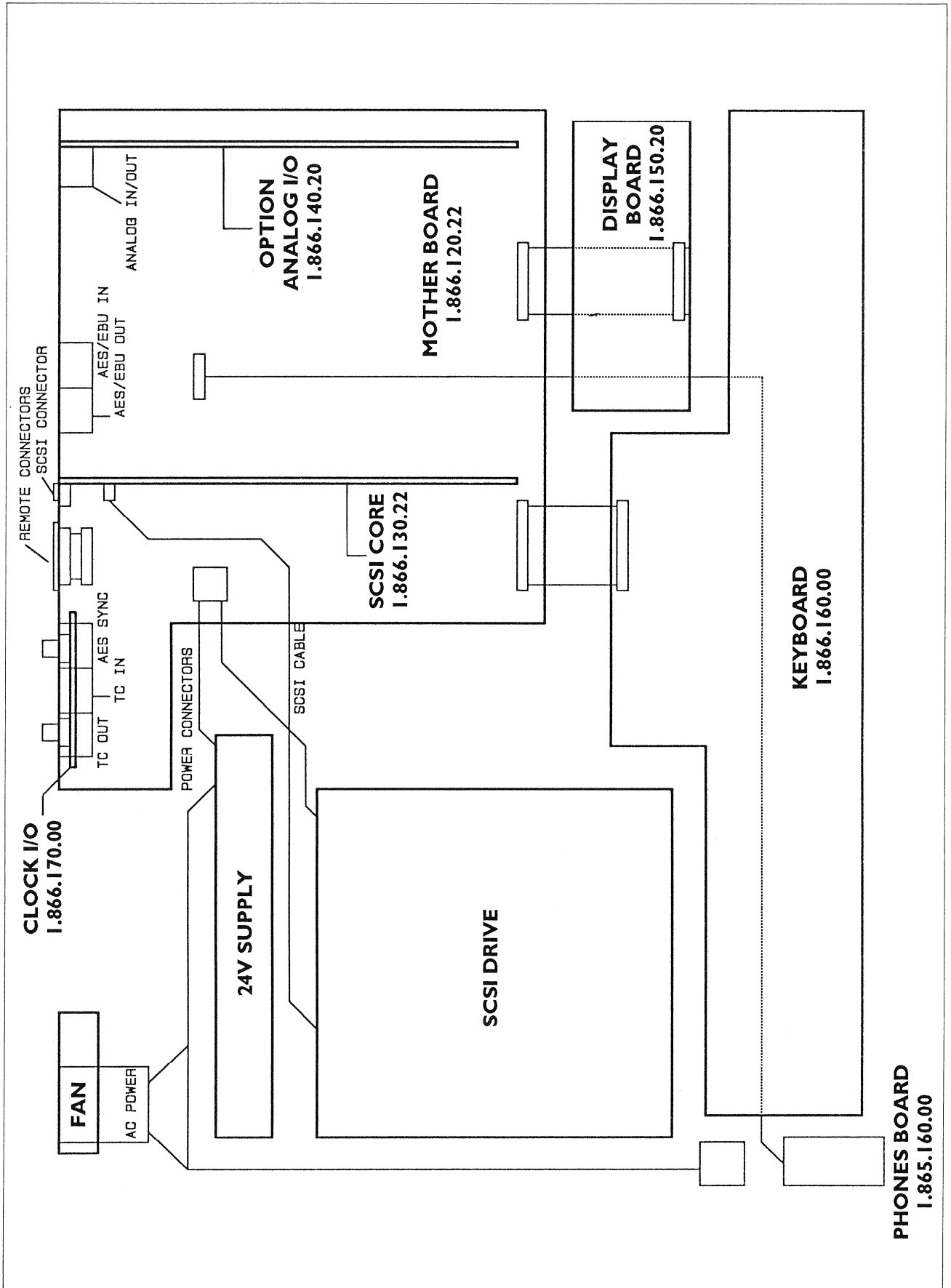

Block Diagram  
Mother Board 1.866.120

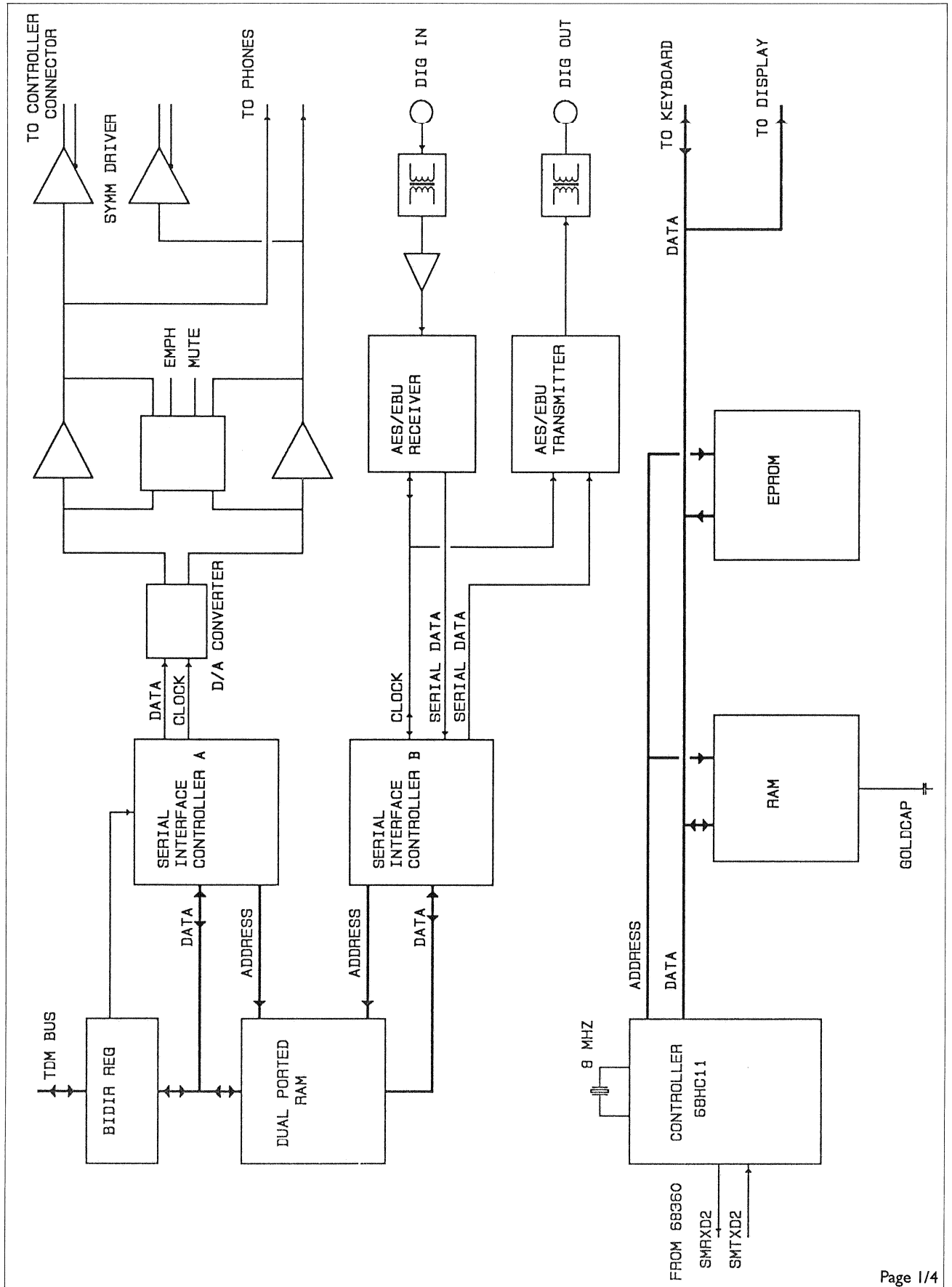

**Block Diagram**  
**Mother Board 1.866.120**

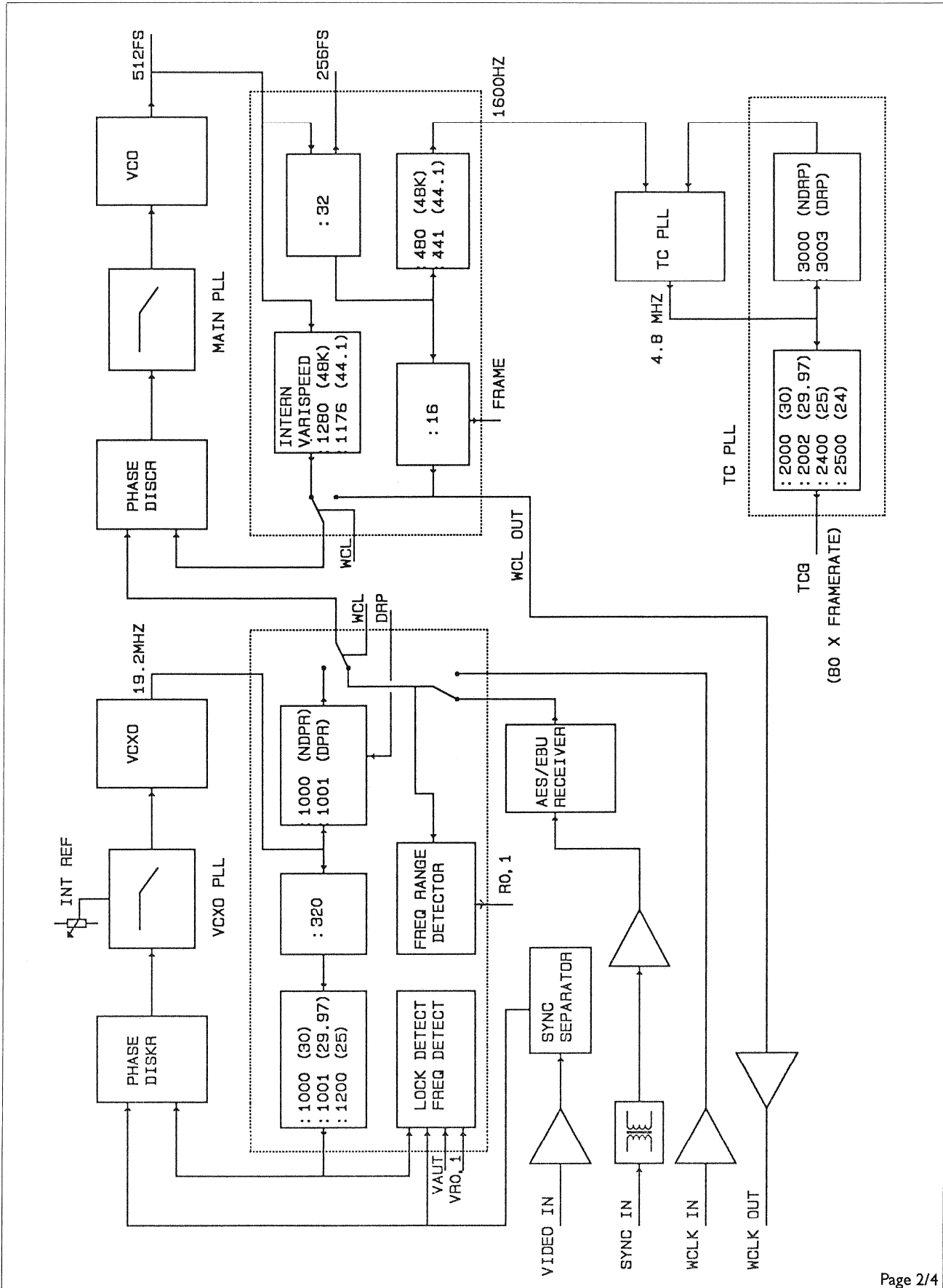

Block Diagram  
Mother Board 1.866.120

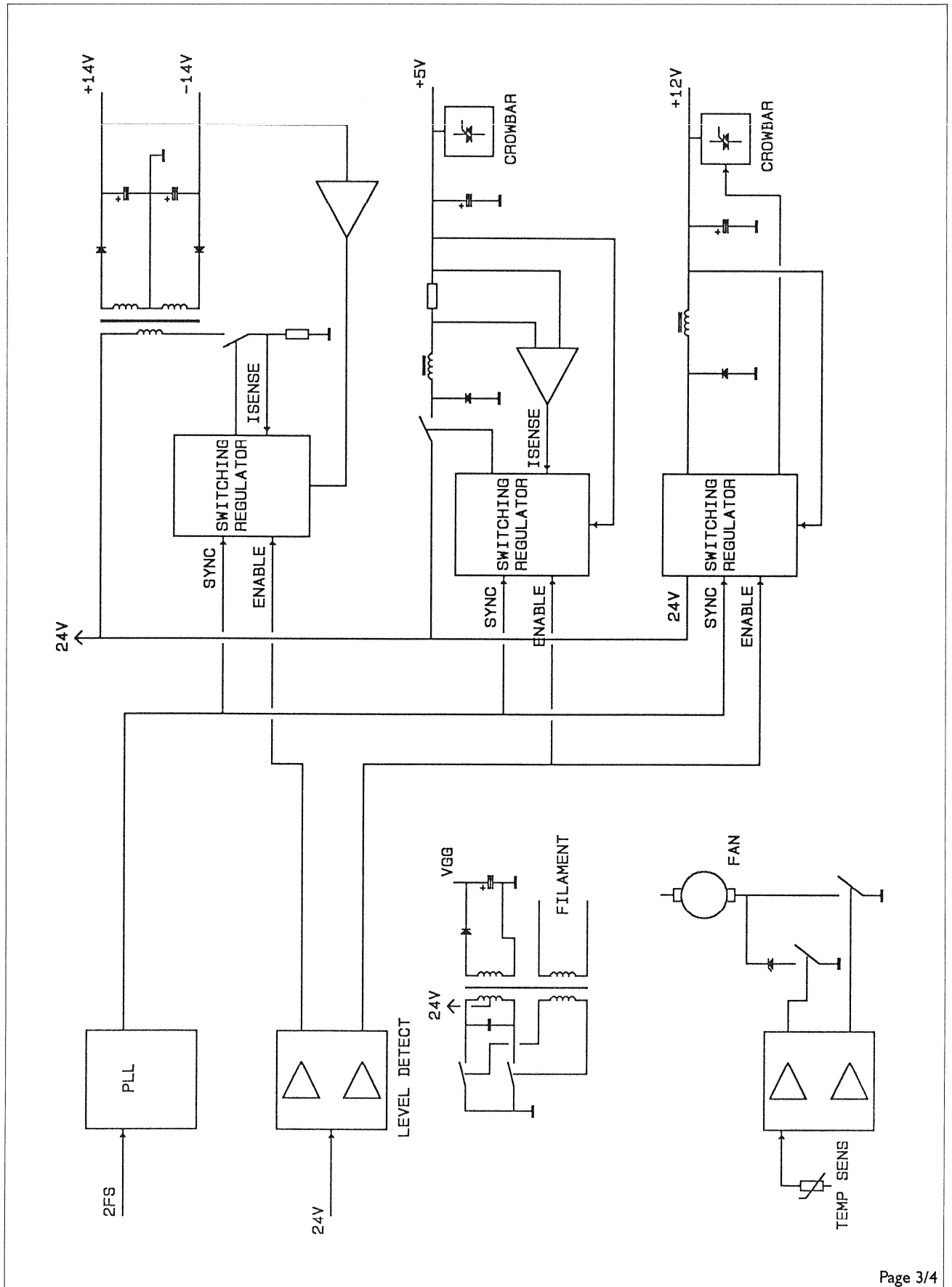

**Block Diagram**  
**Mother Board 1.866.120**

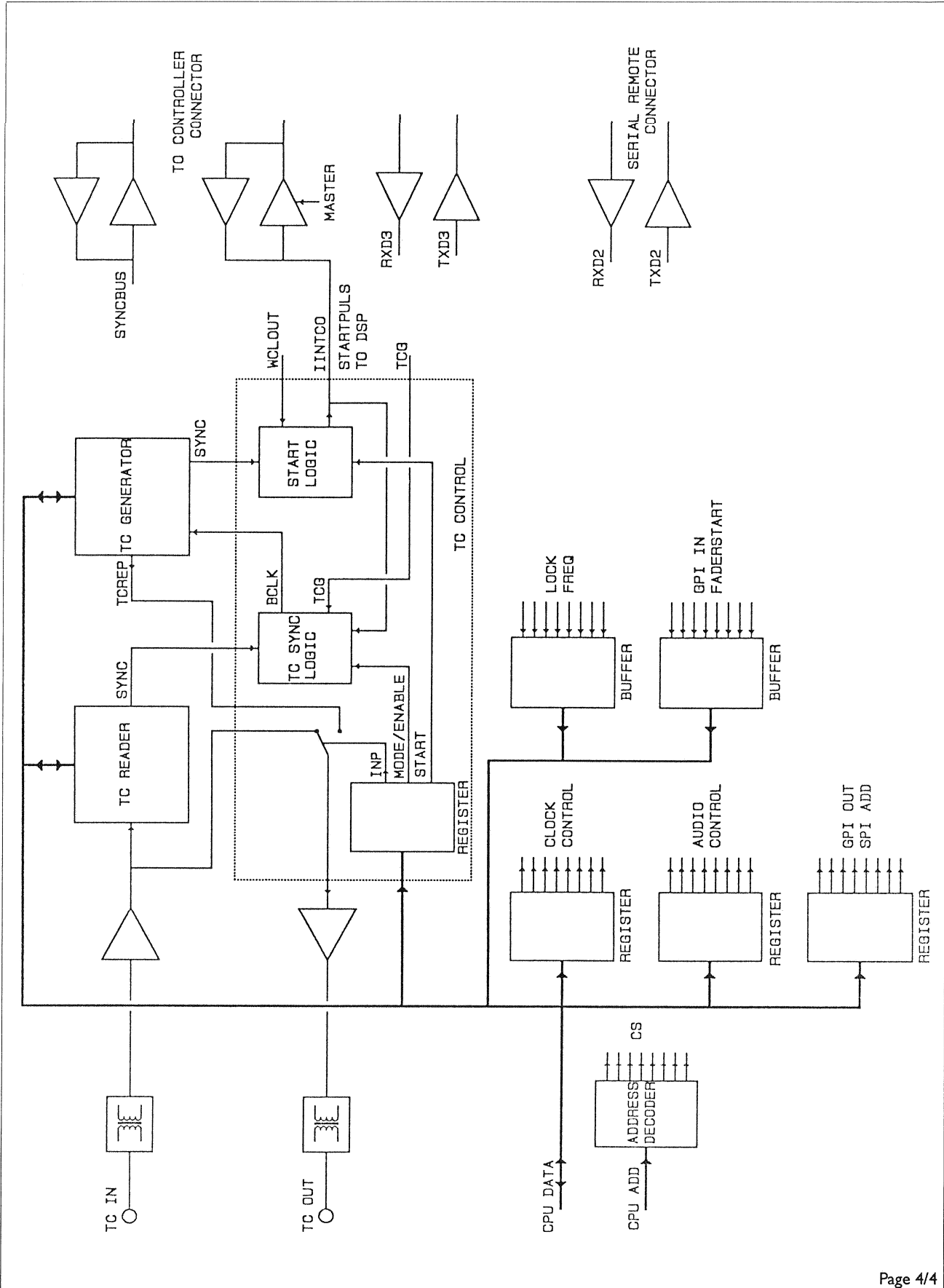



Mother Board 1.866.120.25

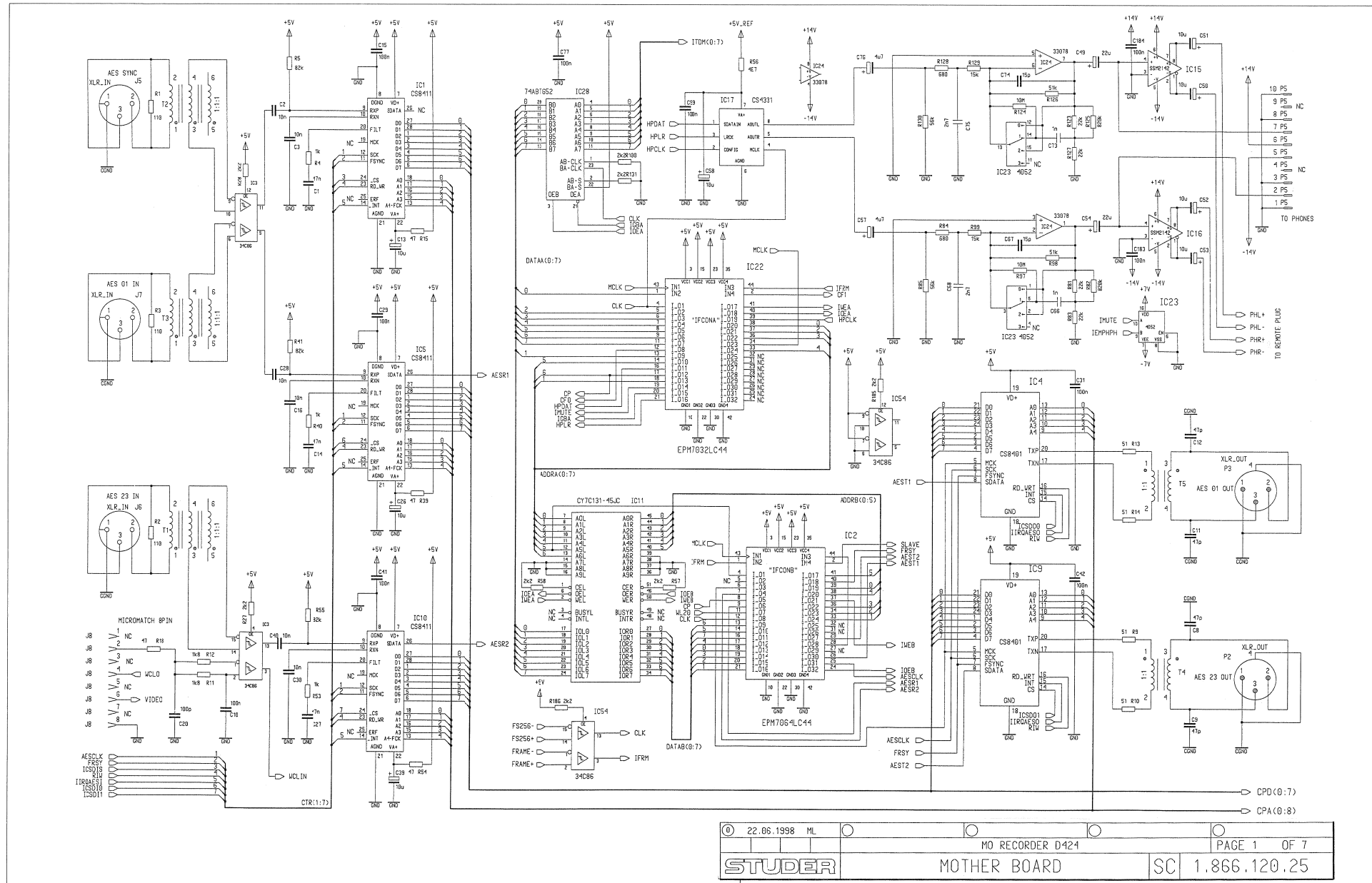

© 22.06.1998 ML	MOTHER BOARD	MO RECORDER D424	PAGE 1 OF 7
STUDER		MOTHER BOARD	SC 1.866.120.25



Mother Board 1.866.120.25

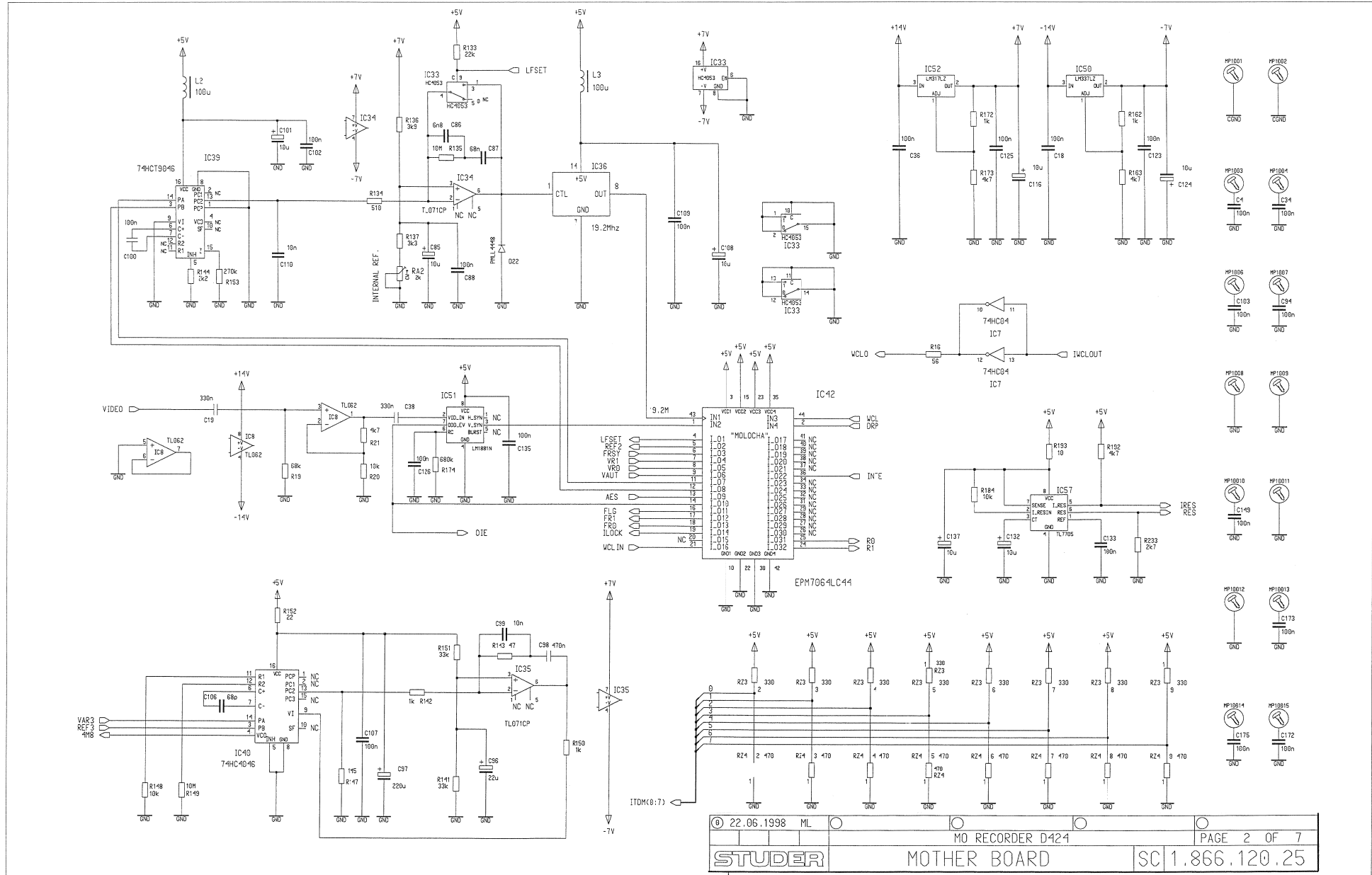

Mother Board 1.866.120.25

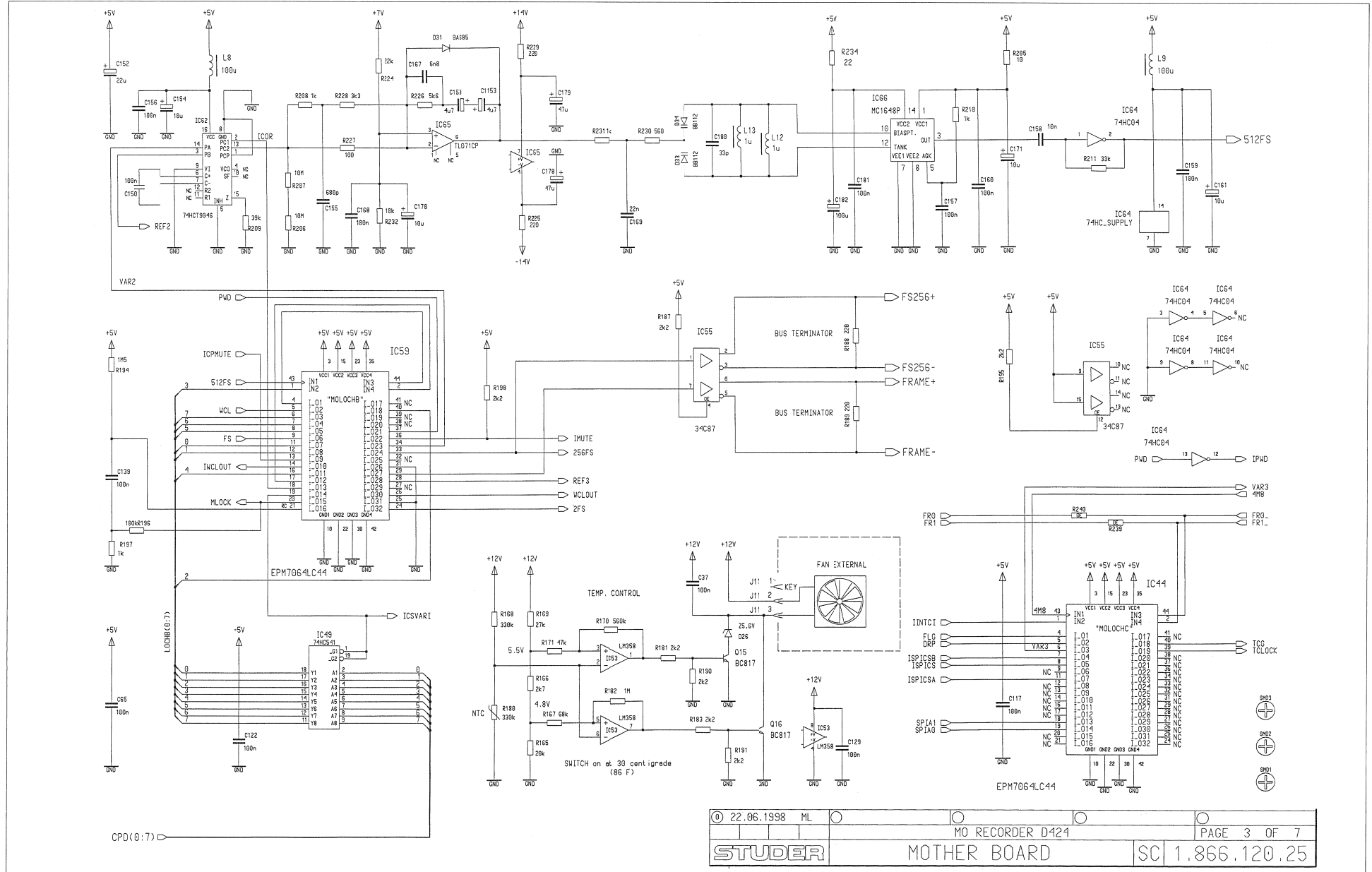









Mother Board 1.866.120.25

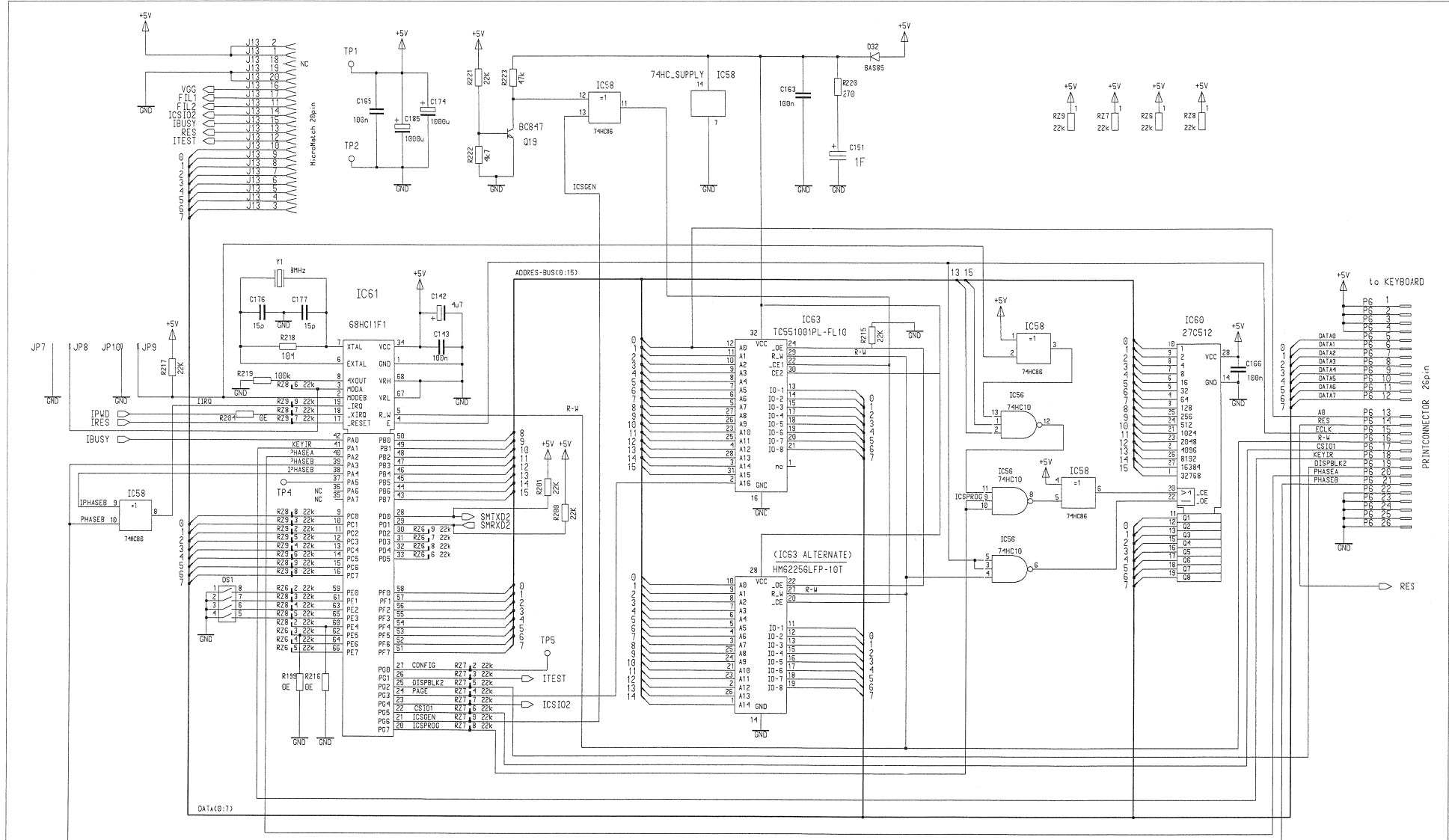







Mother Board 1.866.120.25

Idx	Pos.	Part No.	Qty.	Type/Val.	Description	Idx	Pos.	Part No.	Qty.	Type/Val.	Description
0	C 1	59.60.3333	47n		CER 50V, 10%, X7R, 0805	0	C 92	59.22.5471	470u		EL 25V, 20%, RM5
0	C 2	59.60.3325	10n		CER 50V, 10%, X7R, 0805	0	C 93	59.22.5101	100u		EL 25V, 20%, RM5
0	C 3	59.60.3325	10n		CER 50V, 10%, X7R, 0805	0	C 94	59.60.3337	100n		CER 50V, 10%, X7R, 0805
0	C 4	59.60.3337	100n		CER 50V, 10%, X7R, 0805	0	C 95	59.60.3337	100n		CER 50V, 10%, X7R, 0805
0	C 5	59.60.3337	100n		CER 50V, 10%, X7R, 0805	0	C 96	59.68.0067	22u		C-EL 16V, 5.0*5.7
0	C 6	59.68.0071	100u		C-EL 16V, 8.0*10.7	0	C 97	59.68.0073	220u		C-EL 16V, 8.0*10.7
U	C 7	59.60.2257	220p		CER 50V, 5%, COG, 0603	0	C 98	59.06.0474	470n		PETP, 63V, 10%, RM5
0	C 8	not used	47p		CER 50V, 5%, COG, 0603	0	C 99	59.60.3325	10n		CER 50V, 10%, X7R, 0805
0	C 9	not used	47p		CER 50V, 5%, COG, 0603	0	C 100	59.06.0104	100n		PETP, 63V, 10%, RM5
0	C 10	59.60.3337	100n		CER 50V, 10%, X7R, 0805	0	C 101	59.68.0065	10u		C-EL 16V, 4.0*5.7
0	C 11	59.60.2241	47p		CER 50V, 5%, COG, 0603	0	C 102	59.60.3337	100n		CER 50V, 10%, X7R, 0805
0	C 12	59.60.2241	47p		CER 50V, 5%, COG, 0603	0	C 103	59.60.3337	100n		CER 50V, 10%, X7R, 0805
0	C 13	59.68.0065	10u		C-EL 16V, 4.0*5.7	0	C 104	59.60.2473	1n		CER 50V, 5%, COG, 1206
0	C 14	59.60.3333	47n		CER 50V, 10%, X7R, 0805	0	C 105	59.22.5471	470u		EL 25V, 20%, RM5
0	C 15	59.60.3337	100n		CER 50V, 10%, X7R, 0805	0	C 106	59.60.2245	68p		CER 50V, 5%, COG, 0603
0	C 16	59.60.3325	10n		CER 50V, 10%, X7R, 0805	0	C 107	59.60.3337	100n		CER 50V, 10%, X7R, 0805
0	C 17	59.60.3337	100n		CER 50V, 10%, X7R, 0805	0	C 108	59.68.0065	10u		C-EL 16V, 4.0*5.7
0	C 18	59.60.3337	100n		CER 50V, 10%, X7R, 0805	0	C 109	59.60.3337	100n		CER 50V, 10%, X7R, 0805
0	C 19	59.06.0334	330n		PETP, 63V, 10%, RM5	0	C 110	59.60.3325	10n		CER 50V, 10%, X7R, 0805
0	C 20	59.60.2249	100p		CER 50V, 5%, COG, 0603	0	C 111	59.22.5471	470u		EL 25V, 20%, RM5
0	C 21	59.60.2373	1n0		CER 50V, 5%, COG, 0805	0	C 112	59.60.3329	22n		CER 50V, 10%, X7R, 0805
0	C 22	59.60.2373	1n0		CER 50V, 5%, COG, 0805	0	C 113	59.68.0127	1u0		C-EL 50V, 4.0*5.7
0	C 23	59.60.2373	1n0		CER 50V, 5%, COG, 0805	0	C 114	59.22.5471	470u		EL 25V, 20%, RM5
0	C 24	59.60.2373	1n0		CER 50V, 5%, COG, 0805	0	C 115	59.60.3317	2n2		CER 50V, 10%, X7R, 0805
0	C 25	59.60.2373	1n0		CER 50V, 5%, COG, 0805	0	C 116	59.68.0065	10u		C-EL 16V, 4.0*5.7
0	C 26	59.68.0065	10u		C-EL 16V, 4.0*5.7	0	C 117	59.60.3337	100n		CER 50V, 10%, X7R, 0805
0	C 27	not used	47n		CER 50V, 10%, X7R, 0805	0	C 118	59.60.3337	100n		CER 50V, 10%, X7R, 0805
0	C 28	59.60.3325	10n		CER 50V, 10%, X7R, 0805	0	C 119	59.29.0322	22m		EL 25V RM10 radial
0	C 29	59.60.3337	100n		CER 50V, 10%, X7R, 0805	0	C 120	59.60.2363	390p		CER 50V, 5%, COG, 0805
0	C 30	not used	10n		CER 50V, 10%, X7R, 0805	0	C 121	59.22.8229	2u2		EL 50V, 20%, RM5
0	C 31	59.60.3337	100n		CER 50V, 10%, X7R, 0805	0	C 122	59.60.3337	100n		CER 50V, 10%, X7R, 0805
0	C 32	59.60.3337	100n		CER 50V, 10%, X7R, 0805	0	C 123	59.60.3337	100n		CER 50V, 10%, X7R, 0805
0	C 33	59.68.0065	10u		C-EL 16V, 4.0*5.7	0	C 124	59.68.0065	10u		C-EL 16V, 4.0*5.7
0	C 34	59.60.3337	100n		CER 50V, 10%, X7R, 0805	0	C 125	59.60.3337	100n		CER 50V, 10%, X7R, 0805
0	C 35	59.60.3337	100n		CER 50V, 10%, X7R, 0805	0	C 126	59.60.3337	100n		CER 50V, 10%, X7R, 0805
0	C 36	59.60.3337	100n		CER 50V, 10%, X7R, 0805	0	C 127	59.60.3331	33n		CER 50V, 10%, X7R, 0805
0	C 37	59.60.3337	100n		CER 50V, 10%, X7R, 0805	0	C 128	59.60.2257	220p		CER 50V, 5%, COG, 0603
0	C 38	59.06.0334	330n		PETP, 63V, 10%, RM5	0	C 129	59.60.3337	100n		CER 50V, 10%, X7R, 0805
0	C 39	not used	10u		C-EL 16V, 4.0*5.7	0	C 130	59.22.5471	470u		EL 25V, 20%, RM5
0	C 40	not used	10n		CER 50V, 10%, X7R, 0805	0	C 131	59.22.5471	470u		EL 25V, 20%, RM5
0	C 41	not used	100n		CER 50V, 10%, X7R, 0805	0	C 132	59.68.0065	10u		C-EL 16V, 4.0*5.7
0	C 42	59.60.3337	100n		CER 50V, 10%, X7R, 0805	0	C 133	59.60.3337	100n		CER 50V, 10%, X7R, 0805
0	C 43	59.02.0685	6u8		MPC, 5%, 63V	0	C 134	59.60.3337	100n		CER 50V, 10%, X7R, 0805
0	C 44	59.60.3337	100n		CER 50V, 10%, X7R, 0805	0	C 135	59.60.3337	100n		CER 50V, 10%, X7R, 0805
0	C 45	59.60.3325	10n		CER 50V, 10%, X7R, 0805	0	C 136	59.22.6471	470u		EL 40V, 20%, RM5
0	C 46	59.60.3325	10n		CER 50V, 10%, X7R, 0805	0	C 137	59.68.0065	10u		C-EL 16V, 4.0*5.7
0	C 47	59.60.3337	100n		CER 50V, 10%, X7R, 0805	0	C 138	59.60.3337	100n		CER 50V, 10%, X7R, 0805
0	C 48	59.60.2373	1n0		CER 50V, 5%, COG, 0805	0	C 139	59.60.3337	100n		CER 50V, 10%, X7R, 0805
0	C 49	59.68.0067	22u		C-EL 16V, 5.0*5.7	0	C 140	59.60.3337	100n		CER 50V, 10%, X7R, 0805
0	C 50	59.68.0065	10u		C-EL 16V, 4.0*5.7	0	C 141	59.29.0322	22m		EL 25V RM10 radial
0	C 51	59.68.0065	10u		C-EL 16V, 4.0*5.7	0	C 142	59.68.0107	4u7		C-EL 35V, 4.0*5.7
0	C 52	59.68.0065	10u		C-EL 16V, 4.0*5.7	0	C 143	59.60.3337	100n		CER 50V, 10%, X7R, 0805
0	C 53	59.68.0065	10u		C-EL 16V, 4.0*5.7	0	C 144	59.60.3337	100n		CER 50V, 10%, X7R, 0805
0	C 54	59.68.0067	22u		C-EL 16V, 5.0*5.7	0	C 145	59.22.5471	470u		EL 25V, 20%, RM5
0	C 55	59.68.0065	10u		C-EL 16V, 4.0*5.7	0	C 146	59.22.5471	470u		EL 25V, 20%, RM5
0	C 56	59.06.0332	3n3		PETP, 63V, 10%, RM5	0	C 147	59.22.8100	10u		EL 63V, 20%, RM5
0	C 57	59.68.0107	4u7		C-EL 35V, 4.0*5.7	0	C 148	59.60.3337	100n		CER 50V, 10%, X7R, 0805
0	C 58	59.68.0065	10u		C-EL 16V, 4.0*5.7	0	C 149	59.60.3337	100n		CER 50V, 10%, X7R, 0805
0	C 59	59.60.3337	100n		CER 50V, 10%, X7R, 0805	0	C 150	59.06.0104	100n		PETP, 63V, 10%, RM5
0	C 60	59.60.3337	100n		CER 50V, 10%, X7R, 0805	0	C 151	59.22.1105	1F		EL 5.5V, 20%, rad
0	C 61	59.68.0065	10u		C-EL 16V, 4.0*5.7	0	C 152	59.68.0067	22u		C-EL 16V, 5.0*5.7
0	C 62	59.60.3325	10n		CER 50V, 10%, X7R, 0805	0	C 153	59.68.0107	4u7		C-EL 35V, 4.0*5.7
0	C 63	59.60.3337	100n		CER 50V, 10%, X7R, 0805	0	C 154	59.68.0065	10u		C-EL 16V, 4.0*5.7
0	C 64	59.22.6470	47u		EL 40V, 20%, RM5	0	C 155	59.60.2309	680p		CER 50V, 5%, COG, 0605
0	C 65	59.60.3337	100n		CER 50V, 10%, X7R, 0805	0	C 156	59.60.3337	100n		CER 50V, 10%, X7R, 0805
0	C 66	59.05.1102	1n		PP, 1%, 630V	0	C 157	59.60.3337	100n		CER 50V, 10%, X7R, 0805
0	C 67	59.60.2229	15p		CER 50V, 5%, COG, 0603	0	C 158	59.60.3325	10n		CER 50V, 10%, X7R, 0805
0	C 68	59.05.1272	2n7		PP, 1%, 160V	0	C 159	59.60.3337	100n		CER 50V, 10%, X7R, 0805
0	C 69	59.60.2373	1n0		CER 50V, 5%, COG, 0805	0	C 160	59.60.3337	100n		CER 50V, 10%, X7R, 0805
0	C 70	59.60.2257	220p		CER 50V, 5%, COG, 0603	0	C 161	59.68.0065	10u		C-EL 16V, 4.0*5.7
0	C 71	59.60.3325	10n		CER 50V, 10%, X7R, 0805	0	C 162	59.05.2103	10n		PP, 2.5%, 63V
0	C 72	59.60.3325	10n		CER 50V, 10%, X7R, 0805	0	C 163	59.60.3337	100n		CER 50V, 10%, X7R, 0805
0	C 73	59.05.1102	1n		PP, 1%, 630V	0	C 164	59.60.3337	100n		CER 50V, 10%, X7R, 0805
0	C 74	59.60.2229	15p		CER 50V, 5%, COG, 0603	0	C 165	59.60.3337	100n		CER 50V, 10%, X7R, 0805
0	C 75	59.05.1272	2n7		PP, 1%, 160V	0	C 166	59.60.3337	100n		CER 50V, 10%, X7R, 0805
0	C 76	59.68.0107	4u7		C-EL 35V, 4.0*5.7	0	C 167	59.63.1123	6n8		PPS 50V, 2%, 1206
0	C 77	59.60.3337	100n		CER 50V, 10%, X7R, 0805	0	C 168	59.60.3337	100n		CER 50V, 10%, X7R, 0805
0	C 78	59.60.3337	100n		CER 50V, 10%, X7R, 0805	0	C 169	59.60.3329	22n		CER 50V, 10%, X7R, 0805
0	C 79	59.60.3337	100n		CER 50V, 10%, X7R, 0805	0	C 170	59.68.0065	10u		C-EL 16V, 4.0*5.7
0	C 80	59.22.6470	47u		EL 40V, 20%, RM5	0	C 171	59.68.0065	10u		C-EL 16V, 4.0*5.7
0	C 81	59.06.0104	100n		PETP, 63V, 10%, RM5	0	C 172	59.60.3337	100n		CER 50V, 10%, X7R, 0805
0	C 82	59.06.0104	100n		PETP, 63V, 10%, RM5	0	C 173	59.60.3337	100n		CER 50V, 10%, X7R, 0805
0	C 83	59.22.5101	100u		EL 25V, 20%, RM5	0	C 174	59.68.0035	1000u		C-EL 6V, 10*10.7
0	C 84	59.60.2473	1n		CER 50V, 5%, COG, 1206	0	C 175	59.60.3337	100n		CER 50V, 10%, X7R, 0805
0	C 85	59.68.0065	10u		C-EL 16V, 4.0*5.7	0	C 176	59.60.2229	15p		CER 50V, 5%, COG, 0603
0	C 86	59.60.3323	6n8		CER 50V, 10%, X7R, 0805	0	C 177	59.60.2229	15p		CER 50V, 5%, COG, 0603
0	C 87	59.60.3335	68n		CER 50V, 10%, X7R, 0805	0	C 178	59.68.0113	47u		C-EL 35V, 8.0*6.3
0	C 88	59.60.3337	100n		CER 50V, 10%, X7R, 0805	0	C 179	59.68.0113	47u		C-EL 35V, 8.0*6.3
0	C 89	59.22.3471	470u		EL 10V, 20%, RM5	0	C 180	59.60.2237	33p		CER 50V, 5%, COG, 0603
0	C 90	59.22.3471	470u		EL 10V, 20%, RM5	0	C 181	59.60.3337	100n		CER 50V, 10%, X7R, 0805
0	C 91	59.02.0685	6u8		MPC, 5%, 63V	0	C 182	59.68.0071	100u		C-EL 16V, 8.0*6.3



Mother Board 1.866.120.25

Idx	Pos.	Part No.	Qty.	Type/Val.	Description	Idx	Pos.	Part No.	Qty.	Type/Val.	Description
0	C 183	59.60.3337	100n		CER 50V, 10%, X7R, 0805	0	IC 49	50.62.1541		74HC541	74 HC 541
0	C 184	59.60.3337	100n		CER 50V, 10%, X7R, 0805	0	IC 50	50.10.0109		LM337L	IC LM 337 LZ,
0	C 185	59.68.0035	1000u		C-EL 6V, 10 *10.7	0	IC 51	50.11.0145		LM1881	IC LM 1881 N,
0	C 1011	59.60.3325	10n		CER 50V, 10%, X7R, 0805	0	IC 52	50.10.0108		LM317L	IC LM 317 LZ,
0	C 1153	59.68.0107	4u7		C-EL 35V, 4.0*5.7	0	IC 53	50.61.0202		LM358	IC LM 358 D ,A
0	D 1	50.60.8901		RAV99	D RAV 99, SOT 23	0	IC 54	50.15.0128		34C86	IC DS 34 C 86 TN, MC34C86P ,A
0	D 2	not used		4448	D LL 4448 SOD 80	0	IC 55	50.15.0127		34C87	IC DS 34 C 87 TN, MC34C87P ,A
0	D 3	50.04.1125		30V	Zener, 5%, 0.5W, DO-35	0	IC 56	50.62.1010		74HC 10	74 HC 10
0	D 4	50.04.1125		30V	Zener, 5%, 0.5W, DO-35	0	IC 57	50.63.2001		7705B	Reset Generator
0	D 5	50.04.1125		30V	Zener, 5%, 0.5W, DO-35	0	IC 58	50.62.1086		74HC 86	74 HC 86
0	D 6	50.04.1125		30V	Zener, 5%, 0.5W, DO-35	0	IC 59	1.866.911.20			SW120 MOLOCHB (50.63.4202)
0	D 7	50.04.1125		30V	Zener, 5%, 0.5W, DO-35	0	IC 60	1.866.905.22			SW120 KEYB (50.14.2002)
0	D 8	not used		4448	D LL 4448 SOD 80	0	IC 61	50.63.0007		68HC11F1	IC MC 68 HC 11 F1 FN ,A
0	D 9	50.60.8901		BAV99	D BAV 99, SOT 23	0	IC 62	50.62.4946		74HCT9046	IC .. 74 HCT 9046 , A
0	D 10	50.60.8901		BAV99	D BAV 99, SOT 23	0	IC 63	50.63.1504		128K*8	SRAM, 100ns
0	D 11	50.60.8901		BAV99	D BAV 99, SOT 23	0	IC 64	50.62.1004		74HC 04	74 HC 04
0	D 12	50.60.8101		BAS85	D BAS 85 SOD 80	0	IC 65	50.09.0103		TL071	IC TL 071 CP, ,A
0	D 13	50.60.8001		4448	D LL 4448 SOD 80	0	IC 66	50.11.0112		MC1648	IC MC 1648 P,
0	D 14	50.60.8001		4448	D LL 4448 SOD 80						
0	D 15	50.60.8101		BAS85	D BAS 85 SOD 80	0	J 1	54.11.2024		96p	EU-C 3*32p
0	D 16	50.04.0519		1N5822	3A, Schottky	0	J 2	54.11.2024		96p	EU-C 3*32p
0	D 17	50.04.0519		1N5822	3A, Schottky	0	J 3	54.11.2024		96p	EU-C 3*32p
0	D 18	50.04.1117		12V	Zener, 5%, 0.5W, DO-35	0	J 4	54.21.2205		3p	XLR PCB Winkel lock
0	D 19	50.04.1117		12V	Zener, 5%, 0.5W, DO-35	0	J 5	54.21.2205		3p	XLR PCB Winkel lock
0	D 20	50.04.1108		5V6	Zener, 5%, 0.5W, DO-35	0	J 6	not used		3p	XLR PCB Winkel lock
0	D 21	50.04.0516		USD945	D USD 945,	0	J 7	54.21.2205		3p	XLR PCB Winkel lock
0	D 22	50.60.8001		4448	D LL 4448 SOD 80	0	J 8	54.14.5508		8p	PCB-Buchse gerade
0	D 23	50.60.8901		BAV99	D BAV 99, SOT 23	0	J 9	54.14.5516		16p	PCB-Buchse gerade
0	D 24	50.04.0519		1N5822	3A, Schottky	0	J 10	54.14.5516		16p	PCB-Buchse gerade
0	D 25	50.04.0519		1N5822	3A, Schottky	0	J 11	54.01.0287		3-P	J LEISTE 3 POL CIS AUFST.
0	D 26	50.04.1108		5V6	Zener, 5%, 0.5W, DO-35	0	J 12	54.14.5510		10p	PCB-Buchse gerade
0	D 27	50.60.8001		4448	D LL 4448 SOD 80	0	J 13	54.14.5520		20p	PCB-Buchse gerade
0	D 28	50.60.8001		4448	D LL 4448 SOD 80						
0	D 29	50.60.8001		4448	D LL 4448 SOD 80	0	JP 1	54.01.0020		1p	Pin 0.63*0.63
0	D 30	50.60.8001		4448	D LL 4448 SOD 80	0	JP 2	54.01.0020		1p	Pin 0.63*0.63
0	D 31	50.60.8101		BAS85	D BAS 85 SOD 80	0	JP 3	54.01.0020		1p	Pin 0.63*0.63
0	D 32	50.60.8101		BAS85	D BAS 85 SOD 80	0	JP 4	54.01.0020		1p	Pin 0.63*0.63
0	D 33	50.04.0139		BB112	D BB 112,	0	JP 5	54.01.0020		1p	Pin 0.63*0.63
0	D 34	50.04.0139		BB112	D BB 112,	0	JP 6	54.01.0020		1p	Pin 0.63*0.63
0	DS 1	55.01.0164		4*a	SZ , 4*A, DIL	0	JP 7	54.01.0020		1p	Pin 0.63*0.63
0	IC 1	50.62.0912		CS8411A	IC CS 8411 A	0	JP 8	54.01.0020		1p	Pin 0.63*0.63
0	IC 2	1.866.914.20			SW120 IFCONB (50.63.4202)	0	JP 9	54.01.0020		1p	Pin 0.63*0.63
0	IC 3	50.15.0128		34C86	IC DS 34 C 86 TN, MC34C86P ,A	0	JP 10	54.01.0020		1p	Pin 0.63*0.63
0	IC 4	50.62.0911		CS8401A	IC CS 8401 A	0	L 1	62.03.0040		100uH	5A Toroid Choche
0	IC 5	50.62.0912		CS8411A	IC CS 8411 A	0	L 2	62.60.0125		100uH	10%, SMD 1210
0	IC 6	50.09.0101		TL072	IC TL 072 CN ,A	0	L 3	62.60.0125		100uH	10%, SMD 1210
0	IC 7	50.62.1004		74HC 04	74 HC 04	0	L 4	62.03.0035		180uH	3A Toroid Choche
0	IC 8	50.61.0201		TL062	Dual FET Op-Amp ,A	0	L 5	62.03.0015		72uH	2A Toroid Choche
0	IC 9	not used		CS8401A	IC CS 8401 A	0	L 6	62.03.0040		100uH	5A Toroid Choche
0	IC 10	not used		CS8411A	IC CS 8411 A	0	L 7	62.03.0015		72uH	2A Toroid Choche
0	IC 11	50.63.1702		CY7C130	Dualport SRAM, 1K*8	0	L 8	62.60.0125		100uH	10%, SMD 1210
0	IC 12	50.62.1273		74HC273	74 HC 273	0	L 9	62.60.0125		100uH	10%, SMD 1210
0	IC 13	50.15.0128		34C86	IC DS 34 C 86 TN, MC34C86P ,A	0	L 10	62.02.3102		1mH	10%, radial RM 5
0	IC 14	50.10.0113		UC3843	IC IP 3843 N	0	L 12	62.60.0101		1.0uH	10%, SMD 1210
0	IC 15	50.09.0124		2142	IC SSM 2142 P	0	L 13	62.60.0101		1.0uH	10%, SMD 1210
0	IC 16	50.09.0124		2142	IC SSM 2142 P	0	MP 1	1.865.110.02			KUEHLBLECH
0	IC 17	50.61.8003		CS4331	D/A Converter 18bit Ste SO 8	0	MP 2	21.38.0354		M3*6	Z - Schraube KS A2 blank
0	IC 18	50.61.9001		LM393	Dual voltage comp. SO 8 ,A	0	MP 3	21.38.0354		M3*6	Z - Schraube KS A2 blank
0	IC 19	50.15.0127		34C87	IC DS 34 C 87 TN, MC34C87P ,A	0	MP 4	1.727.350.02			THERMOPLASTIK
0	IC 20	1.866.915.21			SW120 MOTCC (50.63.4201)	0	MP 5	50.20.0316			SOT 93 Glimmerscheibe, zu Clip
0	IC 21	50.10.0104		LM317SP	IC LM 317 SP, .T.	0	MP 6	50.20.2003			Montageclip zu TO 220, N/ISOL.
0	IC 22	1.866.913.21			SW120 IFCONA (50.63.4201)	0	MP 7	50.20.2003			Montageclip zu TO 220, N/ISOL.
0	IC 23	50.07.0024		4052	Dual 4ch analog mux/demux	0	MP 8	50.20.2003			Montageclip zu TO 220, N/ISOL.
0	IC 24	50.61.0204		MC33078	IC MC 33078 P ,A	0	MP 9	50.20.2005			Montageclip zu TO 220, N/ISOL.
0	IC 25	50.15.0115		75176	IC SN 75176 BP, DS 3695 N,	0	MP 10	1.010.001.61			UNTERLAGE ZU 61.01.0270
0	IC 26	50.61.0202		LM358	IC LM 358 D ,A	0	MP 11	1.010.002.61			UNTERLAGE ZU 61.01.0281
0	IC 27	50.62.8046		HC4046	Phase locked loop with vco	0	MP 12	89.01.1499			QUARZ - ISOLIERPLATTE
0	IC 28	50.62.6652		74ABT652	Octal transceiver register	0	MP 13	54.01.0021		Jumper	0.63 * 0.63mm
0	IC 29	50.50.0030		TCGA	SMPTE Time-Code Generator	0	MP 14	54.01.0021		Jumper	0.63 * 0.63mm
0	IC 30	50.50.0020		TCR	SMPTE Time-Code Reader	0	MP 15	1.866.120.12			MOTHER BOARD PCB
0	IC 31	50.10.0113		UC3843	IC IP 3843 N	0	MP 16	1.866.120.10			NR. LABEL
0	IC 32	50.15.0115		75176	IC SN 75176 BP, DS 3695 N,	0	MP 17	43.01.0108		Label	ERE-WARNschild
0	IC 33	50.62.8053		HC4053	Tripple 2ch analog mux/demux	0	MP 18	1.010.001.24			TEXT-ETIK. 5*20 HARDWARE -24
0	IC 34	50.09.0103		TL071	IC TL 071 CP, ,A	0	P 1	54.21.2202		3p	XLR PCB Winkel
0	IC 35	50.09.0103		TL071	IC TL 071 CP, ,A	0	P 2	not used		3p	XLR PCB Winkel
0	IC 36	89.01.1510		19.200MHz	HC 19.200 000 MHZ, VCXO	0	P 3	54.21.2202		3p	XLR PCB Winkel
0	IC 37	50.62.1154		74HC154	74 HC 154	0	P 4	54.02.0409			J GEHAUSE 12 POL MOLEX
0	IC 38	50.62.1273		74HC273	74 HC 273	0	P 5	54.14.2101		10p	P STECKER 10 P, AU, VR, GRADE
0	IC 39	50.62.4946		74HCT9046	IC .. 74 HCT 9046 , A	0	P 6	54.14.2104		26p	P STECKER 26 P, AU, VR, GRADE
0	IC 40	50.62.8046		HC4046	Phase locked loop with vco	0	P 7	54.02.0407		12 pcs	J KONTAKT 1 POL MOLEX
0	IC 41	50.62.1273		74HC273	74 HC 273						
0	IC 42	1.866.910.20			SW120 MOLOCHA (50.63.4202)	0	Q 1	50.03.0340			800mA, 45V, NPN
0	IC 43	50.62.1541		74HC541	74 HC 541	0	Q 2	50.03.0340			800mA, 45V, NPN
0	IC 44	1.866.912.20			SW120 MOLOCHC (50.63.4202)	0	Q 3	50.03.0340			800mA, 45V, NPN
0	IC 45	50.10.0108		LM317L	IC LM 317 LZ,	0	Q 4	50.03.0340			800mA, 45V, NPN
0	IC 46	50.10.0110		L296	IC L 296,	0	Q 5	50.03.0340			800mA, 45V, NPN
0	IC 47	50.99.0126		4N26	Optocoupler	0	Q 6	50.60.1001			Q BC 857 B, SOT 23
0	IC 48	50.62.1541		74HC541	74 HC 541	0	Q 7	50.03.1509			IRF 540, IRF 540 N



Mother Board I.866.120.25

Idx	Pos.	Part No.	Qty.	Type/Val.	Description	Idx	Pos.	Part No.	Qty.	Type/Val.	Description
0	Q 8	50.60.1001		BC857B	Q BC 857 B, SOT 23	0	R 79	57.60.1332	3K3	MF, 1%, 0204, E24	
0	Q 9	50.60.1001		BC857B	Q BC 857 B, SOT 23	0	R 80	57.60.1222	2K2	MF, 1%, 0204, E24	
0	Q 10	50.60.1001		BC857B	Q BC 857 B, SOT 23	0	R 81	57.60.1223	22K	MF, 1%, 0204, E24	
0	Q 11	50.03.1509		IRF540	IRF 540, IRF 540 N	0	R 82	57.60.1824	820K	MF, 1%, 0204, E24	
0	Q 12	50.99.0106		BT138	Q BT 138 - 500 TRIAC	0	R 83	57.60.1223	22K	MF, 1%, 0204, E24	
0	Q 13	50.99.0106		BT138	Q BT 138 - 500 TRIAC	0	R 84	57.60.1681	680R	MF, 1%, 0204, E24	
0	Q 14	50.60.0001		BC847B	Q BC 847 B, SOT 23	0	R 85	57.60.1563	56K	MF, 1%, 0204, E24	
0	Q 15	50.60.0050		BC817-25	Q BC 817-25, NPN SOT 23	0	R 86	57.60.1103	10K	MF, 1%, 0204, E24	
0	Q 16	50.60.0050		BC817-25	Q BC 817-25, NPN SOT 23	0	R 87	57.60.1103	10K	MF, 1%, 0204, E24	
0	Q 17	50.03.0551		BC639	BC 639	0	R 88	57.60.1103	10K	MF, 1%, 0204, E24	
0	Q 18	50.03.0551		BC639	BC 639	0	R 89	57.60.1184	180K	MF, 1%, 0204, E24	
0	Q 19	50.60.0001		BC847B	Q BC 847 B, SOT 23	0	R 90	57.60.1103	10K	MF, 1%, 0204, E24	
0	R 1	57.11.3111		110R	MF, 1%, 0207	0	R 91	57.60.1271	270R	MF, 1%, 0204, E24	
0	R 2	not used		110R	MF, 1%, 0207	0	R 92	57.60.1103	10K	MF, 1%, 0204, E24	
0	R 3	57.11.3111		110R	MF, 1%, 0207	0	R 93	57.60.1153	15K	MF, 1%, 0204, E24	
0	R 4	57.60.1102		1K	MF, 1%, 0204, E24	0	R 94	57.60.1153	15K	MF, 1%, 0204, E24	
0	R 5	57.60.1823		82K	MF, 1%, 0204, E24	0	R 95	57.60.1222	2K2	MF, 1%, 0204, E24	
0	R 6	57.60.1101		100R	MF, 1%, 0204, E24	0	R 96	57.60.1222	2K2	MF, 1%, 0204, E24	
0	R 7	57.60.1472		4K7	MF, 1%, 0204, E24	0	R 97	57.60.1105	10M	MF, 2%, 0204, E24	
0	R 8	57.60.1472		4K7	MF, 1%, 0204, E24	0	R 98	57.60.1513	51K	MF, 1%, 0204, E24	
0	R 9	not used		51R	MF, 1%, 0207	0	R 99	57.60.1153	15K	MF, 1%, 0204, E24	
0	R 10	not used		51R	MF, 1%, 0207	0	R 100	57.60.1222	2K2	MF, 1%, 0204, E24	
0	R 11	57.60.1182		1K8	MF, 1%, 0204, E24	0	R 101	57.60.1103	10K	MF, 1%, 0204, E24	
0	R 12	57.60.1182		1K8	MF, 1%, 0204, E24	0	R 102	57.60.1104	100K	MF, 1%, 0204, E24	
0	R 13	57.11.3510		51R	MF, 1%, 0207	0	R 103	57.56.2010	R010	VWV, 5%, 3 W	
0	R 14	57.11.3510		51R	MF, 1%, 0207	0	R 104	57.60.1103	10K	MF, 1%, 0204, E24	
0	R 15	57.60.1470		47R	MF, 1%, 0204, E24	0	R 105	57.60.1104	100K	MF, 1%, 0204, E24	
0	R 16	57.60.1560		56R	MF, 1%, 0204, E24	0	R 106	57.60.1103	10K	MF, 1%, 0204, E24	
0	R 17	57.60.1272		2K7	MF, 1%, 0204, E24	0	R 107	57.60.1332	3K3	MF, 1%, 0204, E24	
0	R 18	57.60.1470		47R	MF, 1%, 0204, E24	0	R 108	57.60.1102	1K	MF, 1%, 0204, E24	
0	R 19	57.60.1683		68K	MF, 1%, 0204, E24	0	R 109	57.60.1332	3K3	MF, 1%, 0204, E24	
0	R 20	57.60.1103		10K	MF, 1%, 0204, E24	0	R 110	57.60.1154	150K	MF, 1%, 0204, E24	
0	R 21	57.60.1472		4K7	MF, 1%, 0204, E24	0	R 111	57.60.1332	3K3	MF, 1%, 0204, E24	
0	R 22	57.60.1102		1K	MF, 1%, 0204, E24	0	R 112	57.60.1332	3K3	MF, 1%, 0204, E24	
0	R 23	57.60.1102		1K	MF, 1%, 0204, E24	0	R 113	57.60.1562	5K6	MF, 1%, 0204, E24	
0	R 24	57.60.1102		1K	MF, 1%, 0204, E24	0	R 114	57.60.1102	1K	MF, 1%, 0204, E24	
0	R 25	57.60.1102		1K	MF, 1%, 0204, E24	0	R 115	57.60.1562	5K6	MF, 1%, 0204, E24	
0	R 26	57.60.1102		1K	MF, 1%, 0204, E24	0	R 116	57.60.1273	27K	MF, 1%, 0204, E24	
0	R 27	57.60.1222		2K2	MF, 1%, 0204, E24	0	R 117	57.60.1473	47K	MF, 1%, 0204, E24	
0	R 28	57.60.1222		2K2	MF, 1%, 0204, E24	0	R 118	57.60.1683	68K	MF, 1%, 0204, E24	
0	R 29	57.11.3220		22R	MF, 1%, 0207	0	R 119	57.60.1102	1K	MF, 1%, 0204, E24	
0	R 30	57.60.1222		2K2	MF, 1%, 0204, E24	0	R 120	57.11.3220	22R	MF, 1%, 0207	
0	R 31	57.11.3220		22R	MF, 1%, 0207	0	R 121	57.60.1103	10K	MF, 1%, 0204, E24	
0	R 32	57.60.1222		2K2	MF, 1%, 0204, E24	0	R 122	57.60.1103	10K	MF, 1%, 0204, E24	
0	R 33	57.11.3220		22R	MF, 1%, 0207	0	R 123	57.60.1223	22K	MF, 1%, 0204, E24	
0	R 34	57.60.1222		2K2	MF, 1%, 0204, E24	0	R 124	57.60.1106	10M	MF, 2%, 0204, E24	
0	R 35	57.11.3220		22R	MF, 1%, 0207	0	R 125	57.60.1824	820K	MF, 1%, 0204, E24	
0	R 36	57.60.1222		2K2	MF, 1%, 0204, E24	0	R 126	57.60.1513	51K	MF, 1%, 0204, E24	
0	R 37	57.11.3220		22R	MF, 1%, 0207	0	R 127	57.60.1223	22K	MF, 1%, 0204, E24	
0	R 38	57.60.1222		2K2	MF, 1%, 0204, E24	0	R 128	57.60.1681	680R	MF, 1%, 0204, E24	
0	R 39	57.60.1470		47R	MF, 1%, 0204, E24	0	R 129	57.60.1153	15K	MF, 1%, 0204, E24	
0	R 40	57.60.1102		1K	MF, 1%, 0204, E24	0	R 130	57.60.1563	56K	MF, 1%, 0204, E24	
0	R 41	57.60.1823		82K	MF, 1%, 0204, E24	0	R 131	57.60.1222	2K2	MF, 1%, 0204, E24	
0	R 42	57.11.3220		22R	MF, 1%, 0207	0	R 132	57.60.1103	10K	MF, 1%, 0204, E24	
0	R 43	57.60.1271		270R	MF, 1%, 0204, E24	0	R 133	57.60.1223	22K	MF, 1%, 0204, E24	
0	R 44	57.60.1104		100K	MF, 1%, 0204, E24	0	R 134	57.60.1511	510R	MF, 1%, 0204, E24	
0	R 45	57.60.1562		5K6	MF, 1%, 0204, E24	0	R 135	57.60.1106	10M	MF, 2%, 0204, E24	
0	R 46	57.60.1222		2K2	MF, 1%, 0204, E24	0	R 136	57.60.1392	3K9	MF, 1%, 0204, E24	
0	R 47	57.60.1332		3K3	MF, 1%, 0204, E24	0	R 137	57.60.1152	1K5	MF, 1%, 0204, E24	
0	R 48	57.92.7020		0.75A	POLY- PTC, 60V	0	R 138	57.60.1103	10K	MF, 1%, 0204, E24	
0	R 49	57.92.7020		0.75A	POLY- PTC, 60V	0	R 139	57.60.1103	10K	MF, 1%, 0204, E24	
0	R 50	57.60.1472		4K7	MF, 1%, 0204, E24	0	R 140	57.60.1103	10K	MF, 1%, 0204, E24	
0	R 51	57.60.1151		150R	MF, 1%, 0204, E24	0	R 141	57.60.1333	33K	MF, 1%, 0204, E24	
0	R 52	57.60.1472		4K7	MF, 1%, 0204, E24	0	R 142	57.60.1102	1K	MF, 1%, 0204, E24	
0	R 53	not used		1K	MF, 1%, 0204, E24	0	R 143	57.60.1470	47R	MF, 1%, 0204, E24	
0	R 54	not used		47R	MF, 1%, 0204, E24	0	R 144	57.60.1222	2K2	MF, 1%, 0204, E24	
0	R 55	not used		82K	MF, 1%, 0204, E24	0	R 145	57.60.1569	5R6	MF, 2%, 0204, E24	
0	R 56	57.60.1479		4R7	MF, 2%, 0204, E24	0	R 146	57.60.1222	2K2	MF, 1%, 0204, E24	
0	R 57	57.60.1222		2K2	MF, 1%, 0204, E24	0	R 147	57.60.1155	1M5	MF, 1%, 0204, E24	
0	R 58	57.60.1222		2K2	MF, 1%, 0204, E24	0	R 148	57.60.1103	10K	MF, 1%, 0204, E24	
0	R 59	57.11.3109		1R0	MF, 1%, 0207	0	R 149	57.60.1106	10M	MF, 2%, 0204, E24	
0	R 60	57.11.3109		1R0	MF, 1%, 0207	0	R 150	57.60.1102	1K	MF, 1%, 0204, E24	
0	R 61	57.11.3109		1R0	MF, 1%, 0207	0	R 151	57.60.1333	33K	MF, 1%, 0204, E24	
0	R 62	57.60.1102		1K	MF, 1%, 0204, E24	0	R 152	57.11.3220	22R	MF, 1%, 0207	
0	R 63	57.60.1473		47K	MF, 1%, 0204, E24	0	R 153	57.60.1274	270K	MF, 1%, 0204, E24	
0	R 64	57.60.1222		2K2	MF, 1%, 0204, E24	0	R 154	57.60.1102	1K	MF, 1%, 0204, E24	
0	R 65	57.60.1154		150K	MF, 1%, 0204, E24	0	R 155	57.60.1472	4K7	MF, 1%, 0204, E24	
0	R 66	57.60.1222		2K2	MF, 1%, 0204, E24	0	R 156	57.60.1103	10K	MF, 1%, 0204, E24	
0	R 67	57.60.1103		10K	MF, 1%, 0204, E24	0	R 157	57.60.1103	10K	MF, 1%, 0204, E24	
0	R 68	57.60.1103		10K	MF, 1%, 0204, E24	0	R 158	57.60.1103	10K	MF, 1%, 0204, E24	
0	R 69	57.60.1103		10K	MF, 1%, 0204, E24	0	R 159	57.60.1103	10K	MF, 1%, 0204, E24	
0	R 70	57.60.1623		62K	MF, 1%, 0204, E24	0	R 160	57.60.1103	10K	MF, 1%, 0204, E24	
0	R 71	57.60.1273		27K	MF, 1%, 0204, E24	0	R 161	57.60.1580	56R	MF, 1%, 0204, E24	
0	R 72	57.60.1821		820R	MF, 1%, 0204, E24	0	R 162	57.60.1102	1K	MF, 1%, 0204, E24	
0	R 73	57.11.3220		22R	MF, 1%, 0207	0	R 163	57.60.1472	4K7	MF, 1%, 0204, E24	
0	R 74	57.60.1220		22R	MF, 1%, 0204, E24	0	R 164	57.60.1332	3K3	MF, 1%, 0204, E24	
0	R 75	57.60.1103		10K	MF, 1%, 0204, E24	0	R 165	57.60.1203	20K	MF, 1%, 0204, E24	
0	R 76	57.60.1562		5K6	MF, 1%, 0204, E24	0	R 166	57.60.1272	2K7	MF, 1%, 0204, E24	
0	R 77	57.60.1562		5K6	MF, 1%, 0204, E24	0	R 167	57.60.1683	68K	MF, 1%, 0204, E24	
0	R 78	57.60.1103		10K	MF, 1%, 0204, E24	0	R 168	57.60.1334	330K	MF, 1%, 0204, E24	





Mother Board I.866.120.25

Idx	Pos.	Part No.	Qty.	Type/Val.	Description	Idx	Pos.	Part No.	Qty.	Type/Val.	Description
0	R 169	57.60.1273	27K	MF, 1%, 0204, E24		0	T 6	1.022.215.00	4:1:1		TIME CODE OUTPUT TRANSFORMER
0	R 170	57.60.1564	560K	MF, 1%, 0204, E24		0	T 7	1.022.409.00	1:3		SUMMEN-TRAFO 1:3
0	R 171	57.60.1473	47K	MF, 1%, 0204, E24		0	T 8	1.022.654.00			TRAFO +/-14V
0	R 172	57.60.1102	1K	MF, 1%, 0204, E24		0	T 9	1.022.220.00			IMPULSEBERTRAGER
0	R 173	57.60.1472	4K7	MF, 1%, 0204, E24		0	T 10	1.022.653.00			TRAFO VF-DISPLAY
0	R 174	57.60.1684	680K	MF, 1%, 0204, E24							
0	R 175	57.60.1103	10K	MF, 1%, 0204, E24		0	TP 1	54.02.0320	1p		Flatpin, 2.8*0.8mm
0	R 176	57.60.1101	100R	MF, 1%, 0204, E24		0	TP 2	54.02.0320	1p		Flatpin, 2.8*0.8mm
0	R 177	57.60.1472	4K7	MF, 1%, 0204, E24		0	TP 3	54.02.0320	1p		Flatpin, 2.8*0.8mm
0	R 178	57.60.1332	3K3	MF, 1%, 0204, E24		0	TP 4	54.02.0320	1p		Flatpin, 2.8*0.8mm
0	R 179	57.60.1472	4K7	MF, 1%, 0204, E24		0	TP 5	54.02.0320	1p		Flatpin, 2.8*0.8mm
0	R 180	57.99.0801	330k	5% NTC		0	TP 6	54.02.0320	1p		Flatpin, 2.8*0.8mm
0	R 181	57.60.1222	2K2	MF, 1%, 0204, E24		0	TP 7	54.02.0320	1p		Flatpin, 2.8*0.8mm
0	R 182	57.60.1105	1M	MF, 1%, 0204, E24							
0	R 183	57.60.1222	2K2	MF, 1%, 0204, E24		0	XIC 2	53.03.2244	PLCC44p		PLCC-Socket 44p
0	R 184	57.60.1103	10K	MF, 1%, 0204, E24		0	XIC 3	53.03.0168	16p		DIL 0.3", lötl, gerade
0	R 185	57.60.1222	2K2	MF, 1%, 0204, E24		0	XIC 11	53.03.2252	PLCC52p		PLCC-Socket 52p
0	R 186	57.60.1222	2K2	MF, 1%, 0204, E24		0	XIC 13	53.03.0168	16p		DIL 0.3", lötl, gerade
0	R 187	57.60.1222	2K2	MF, 1%, 0204, E24		0	XIC 15	53.03.0166	8p		DIL 0.3", lötl, gerade
0	R 188	57.60.1221	220R	MF, 1%, 0204, E24		0	XIC 16	53.03.0166	8p		DIL 0.3", lötl, gerade
0	R 189	57.60.1221	220R	MF, 1%, 0204, E24		0	XIC 19	53.03.0168	16p		DIL 0.3", lötl, gerade
0	R 190	57.60.1222	2K2	MF, 1%, 0204, E24		0	XIC 20	53.03.2244	PLCC44p		PLCC-Socket 44p
0	R 191	57.60.1222	2K2	MF, 1%, 0204, E24		0	XIC 22	53.03.2244	PLCC44p		PLCC-Socket 44p
0	R 192	57.60.1472	4K7	MF, 1%, 0204, E24		0	XIC 25	53.03.0166	8p		DIL 0.3", lötl, gerade
0	R 193	57.60.1100	10R	MF, 1%, 0204, E24		0	XIC 29	53.03.2244	PLCC44p		PLCC-Socket 44p
0	R 194	57.60.1155	1M5	MF, 1%, 0204, E24		0	XIC 30	53.03.2244	PLCC44p		PLCC-Socket 44p
0	R 195	57.60.1222	2K2	MF, 1%, 0204, E24		0	XIC 32	53.03.0166	8p		DIL 0.3", lötl, gerade
0	R 196	57.60.1104	100K	MF, 1%, 0204, E24		0	XIC 42	53.03.2244	PLCC44p		PLCC-Socket 44p
0	R 197	57.60.1102	1K	MF, 1%, 0204, E24		0	XIC 44	53.03.2244	PLCC44p		PLCC-Socket 44p
0	R 198	57.60.1222	2K2	MF, 1%, 0204, E24		0	XIC 59	53.03.2244	PLCC44p		PLCC-Socket 44p
0	R 199	57.60.1000	0R0	MF, 0204		0	XIC 60	53.03.0173	28p		DIL 0.6", lötl, gerade
0	R 200	57.60.1223	22K	MF, 1%, 0204, E24		0	XIC 61	53.03.2268	PLCC68p		PLCC-Socket 68p
0	R 201	57.60.1223	22K	MF, 1%, 0204, E24							
0	R 202	57.60.1562	5K6	MF, 1%, 0204, E24		0	Y 1	89.01.1008	8.0000MHz	8.000 000 MHz, HC 18/U	
0	R 203	57.56.5100	10R	VVV, 10%, 4 W							
0	R 204	not used	0R0	MF, 0204							
0	R 205	57.60.1100	10R	MF, 1%, 0204, E24							
0	R 206	57.60.1106	10M	MF, 1%, 0204, E24							
0	R 207	57.60.1106	10M	MF, 1%, 0204, E24							
0	R 208	57.60.1102	1K	MF, 1%, 0204, E24							
0	R 209	57.60.1393	39K	MF, 1%, 0204, E24							
0	R 210	57.60.1102	1K	MF, 1%, 0204, E24							
0	R 211	57.60.1333	33K	MF, 1%, 0204, E24							
0	R 212	57.60.1471	470R	MF, 1%, 0204, E24							
0	R 213	57.60.1471	470R	MF, 1%, 0204, E24							
0	R 214	57.60.1103	10K	MF, 1%, 0204, E24							
0	R 215	57.60.1223	22K	MF, 1%, 0204, E24							
0	R 216	57.60.1000	0R0	MF, 0204							
0	R 217	57.60.1223	22K	MF, 1%, 0204, E24							
0	R 218	57.60.1106	10M	MF, 1%, 0204, E24							
0	R 219	57.60.1104	100K	MF, 1%, 0204, E24							
0	R 220	57.11.3271	270R	MF, 1%, 0207							
0	R 221	57.60.1223	22K	MF, 1%, 0204, E24							
0	R 222	57.60.1472	4K7	MF, 1%, 0204, E24							
0	R 223	57.60.1473	47K	MF, 1%, 0204, E24							
0	R 224	57.60.1223	22K	MF, 1%, 0204, E24							
0	R 225	57.60.1221	220R	MF, 1%, 0204, E24							
0	R 226	57.60.1562	5K6	MF, 1%, 0204, E24							
0	R 227	57.60.1101	100R	MF, 1%, 0204, E24							
0	R 228	57.60.1332	3K3	MF, 1%, 0204, E24							
0	R 229	57.60.1221	220R	MF, 1%, 0204, E24							
0	R 230	57.60.1471	470R	MF, 1%, 0204, E24							
0	R 231	57.60.1102	1K	MF, 1%, 0204, E24							
0	R 232	57.60.1103	10K	MF, 1%, 0204, E24							
0	R 233	57.60.1272	2K7	MF, 1%, 0204, E24							
0	R 234	57.60.1220	22R	MF, 1%, 0204, E24							
0	R 235	57.60.1334	330K	MF, 1%, 0204, E24							
0	R 236	57.60.1562	5K6	MF, 1%, 0204, E24							
0	R 237	not used	0R0	MF, 0204							
0	R 238	not used	0R0	MF, 0204							
0	R 239	57.60.1000	0R0	MF, 0204							
0	R 240	57.60.1000	0R0	MF, 0204							
0	RA 1	58.01.8501	500R	Cermet, 10%, 0.5W, horizontal							
0	RA 2	58.05.1232	2k	10%, 0.5W, Cermet							
0	RZ 1	57.88.4103	8*10k	2%, SIP 9							
0	RZ 2	57.88.4103	8*10k	2%, SIP 9							
0	RZ 3	57.88.4331	8*330R	2%, SIP 9							
0	RZ 4	57.88.4471	8*470R	2%, SIP 9							
0	RZ 5	57.88.4103	8*10k	2%, SIP 9							
0	RZ 6	57.88.4223	8*22k	2%, SIP 9							
0	RZ 7	57.88.4223	8*22k	2%, SIP 9							
0	RZ 8	57.88.4223	8*22k	2%, SIP 9							
0	RZ 9	57.88.4223	8*22k	2%, SIP 9							
0	T 1	not used		IMPULSTRANSFORMATOR							
0	T 2	63.15.0001		IMPULSTRANSFORMATOR							
0	T 3	63.15.0001		IMPULSTRANSFORMATOR							
0	T 4	not used	1:1	DI/DO TRANSFORMER							
0	T 5	1.022.632.00	1:1	DI/DO TRANSFORMER							

End of List

Comments

Block Diagram  
SCSI Core 1.866.130

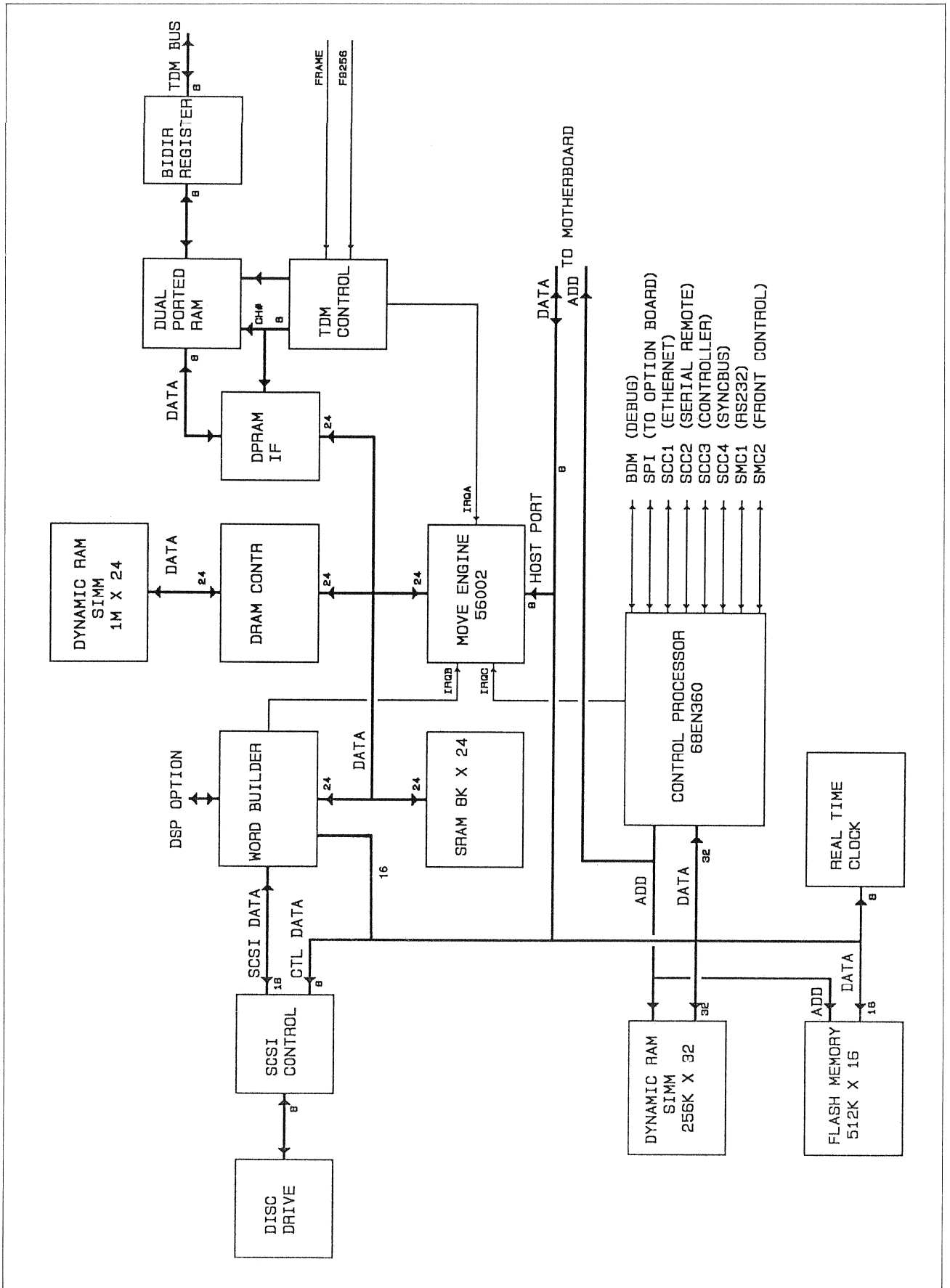

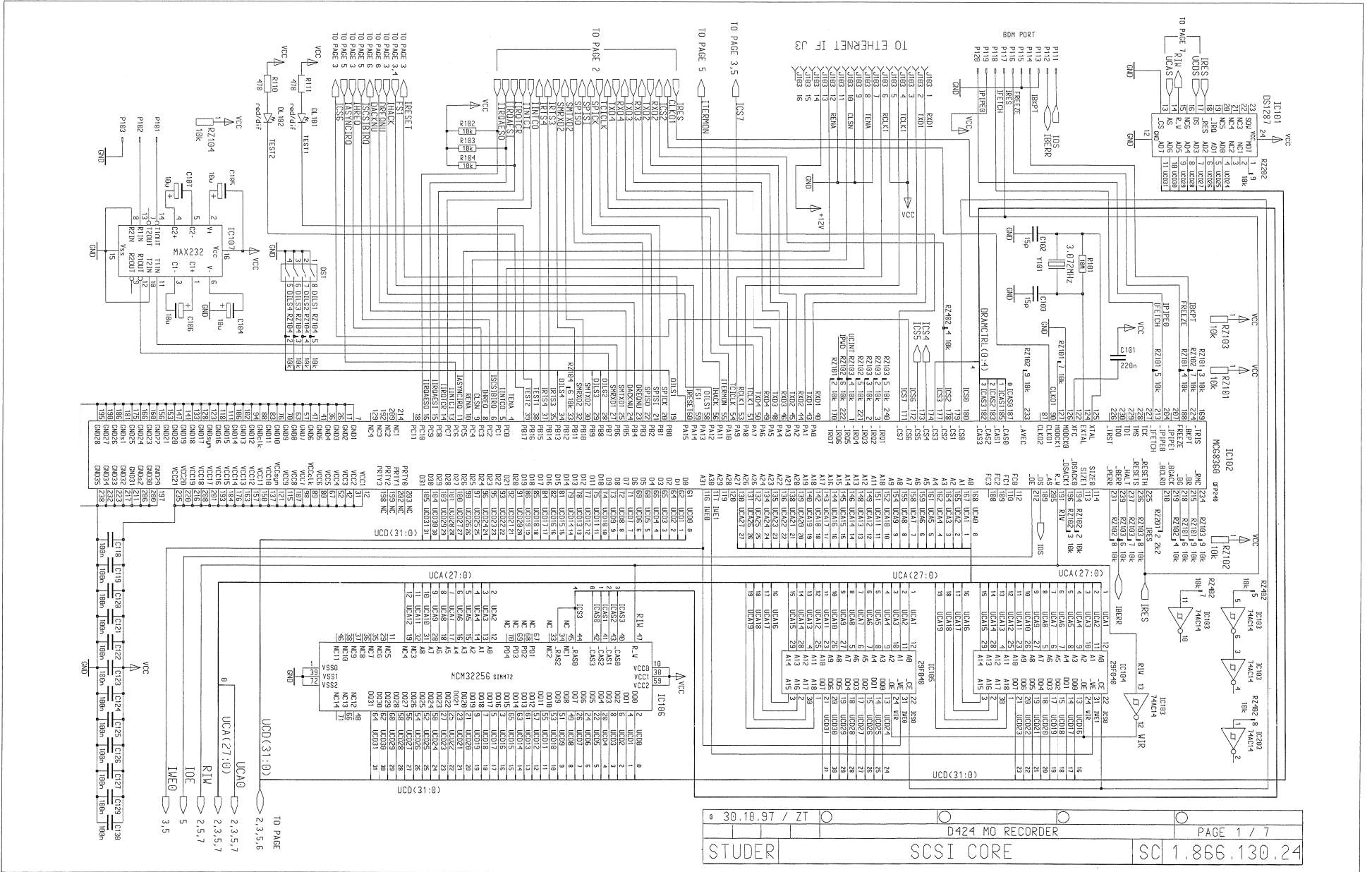



SCSI Core 1.866.130.25

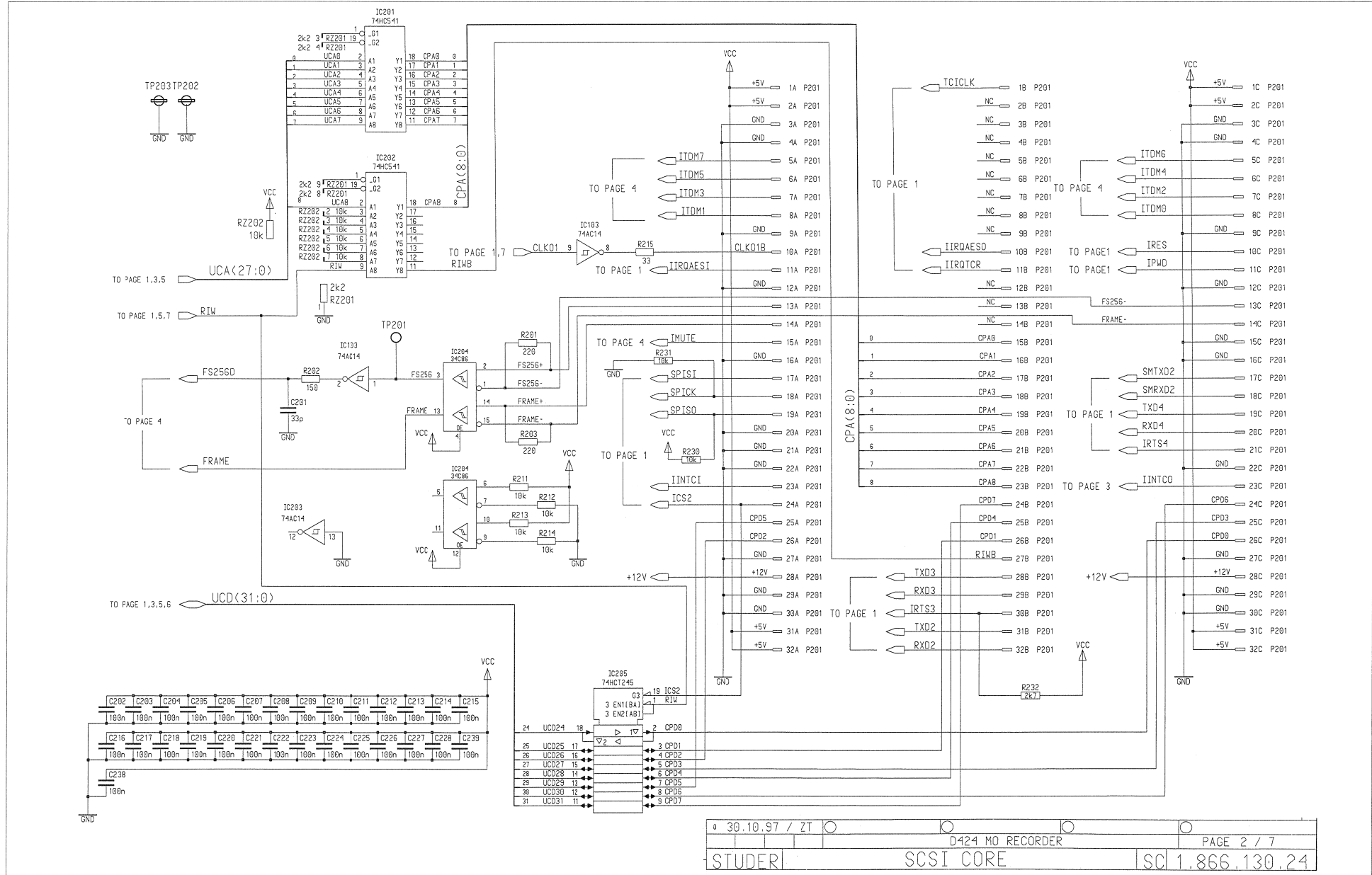

SCSI Core 1.866.130.25

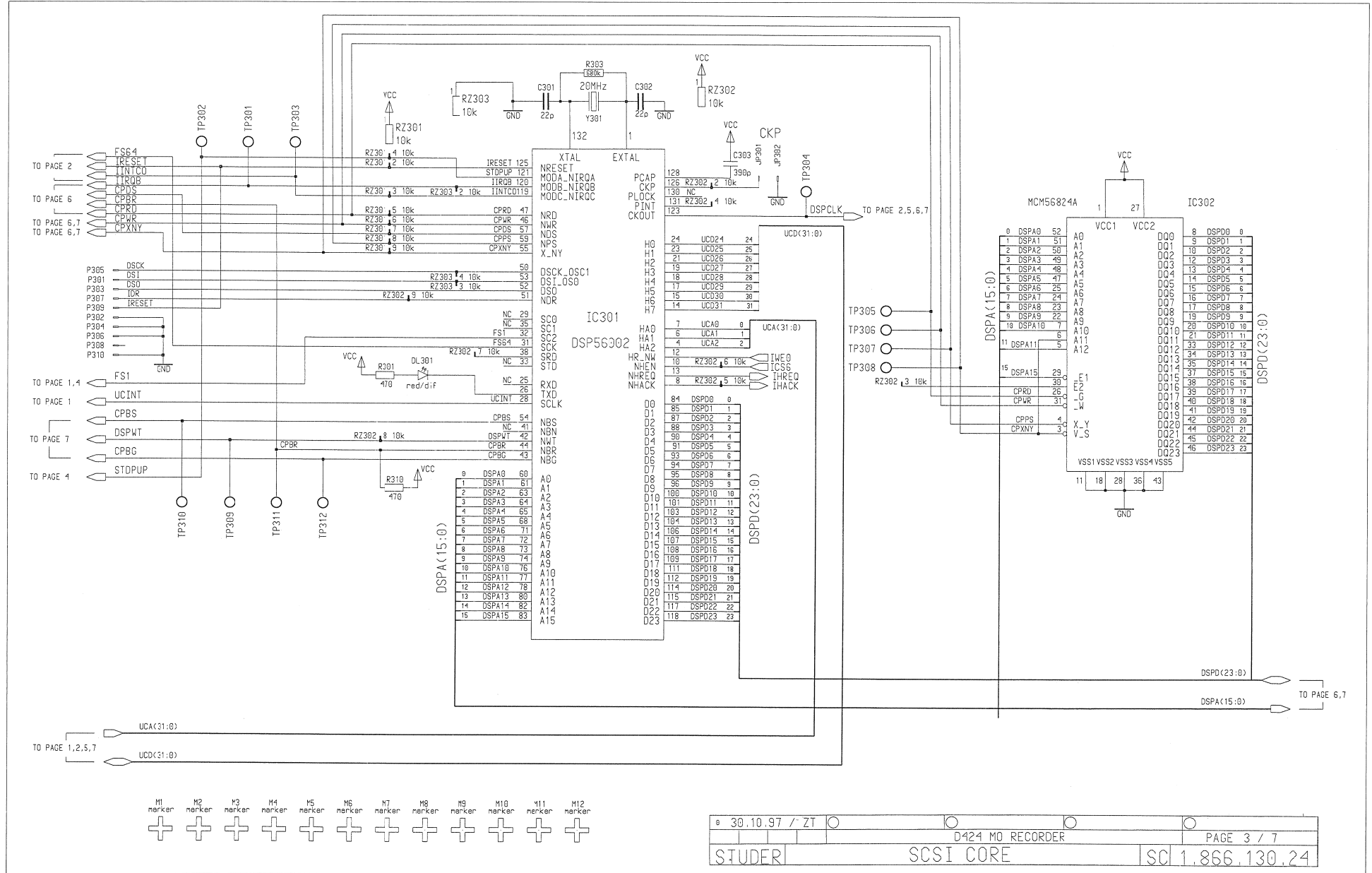



SCSI Core 1.866.130.25

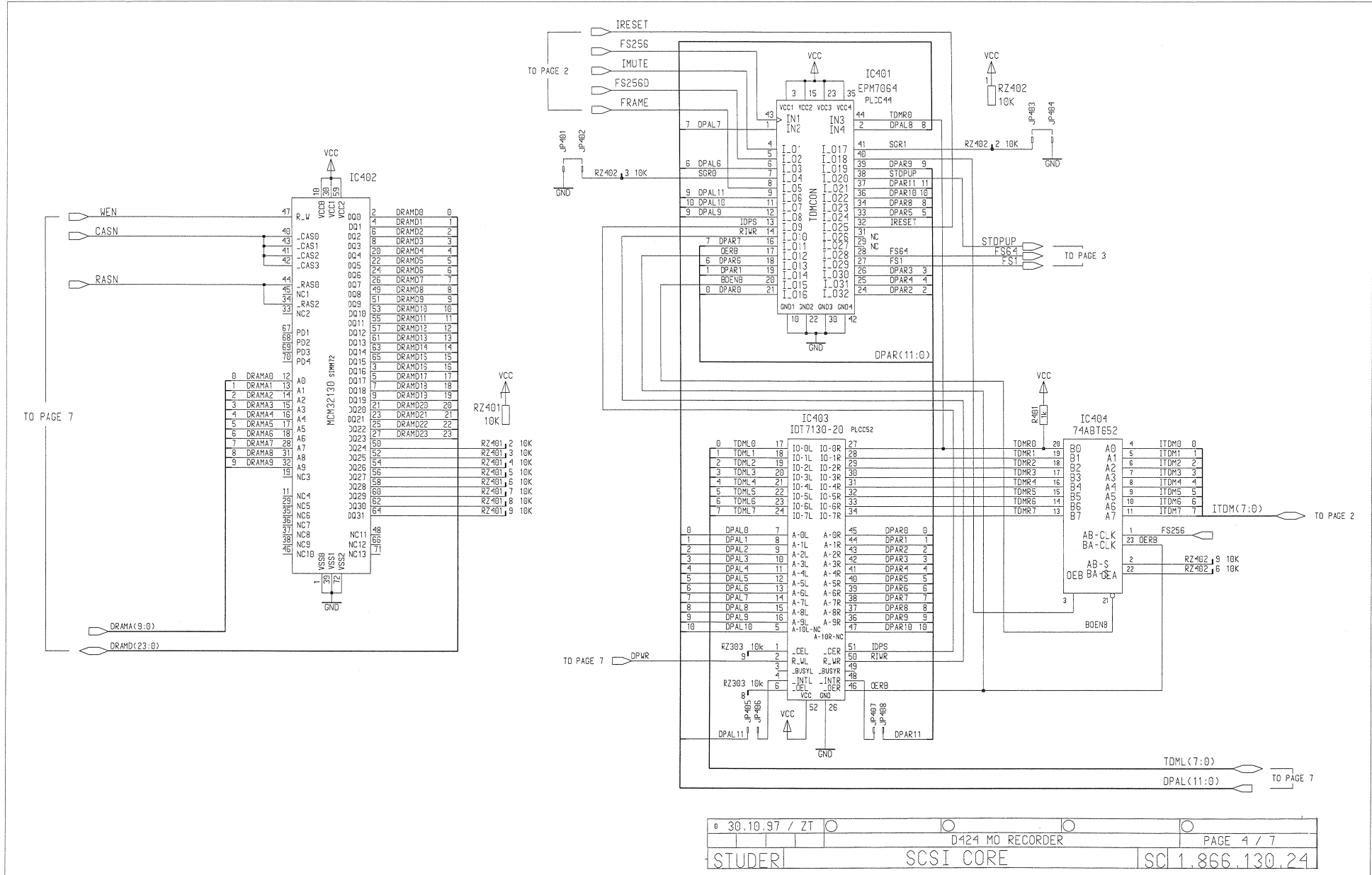



SCSI Core 1.866.130.25

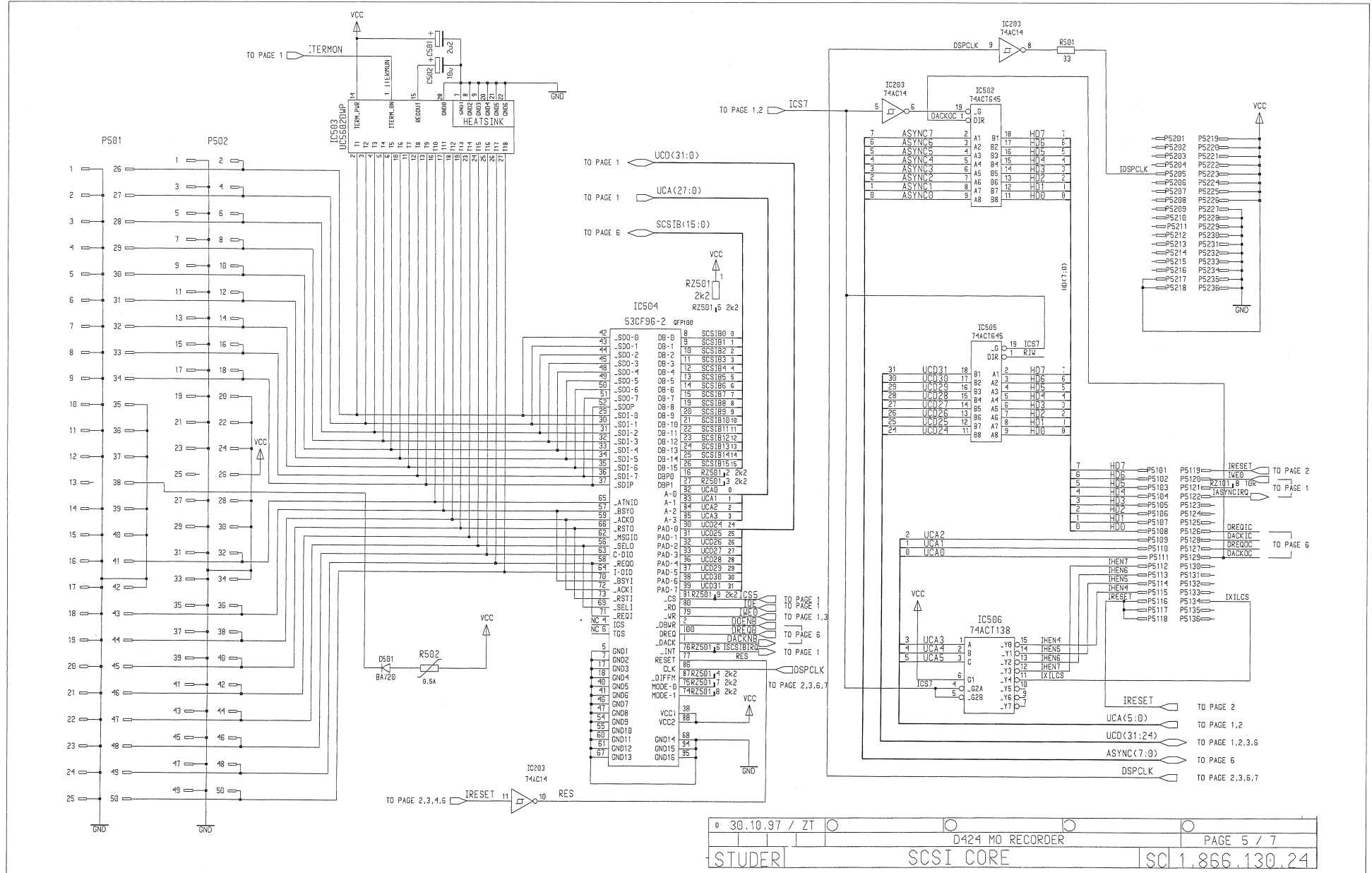





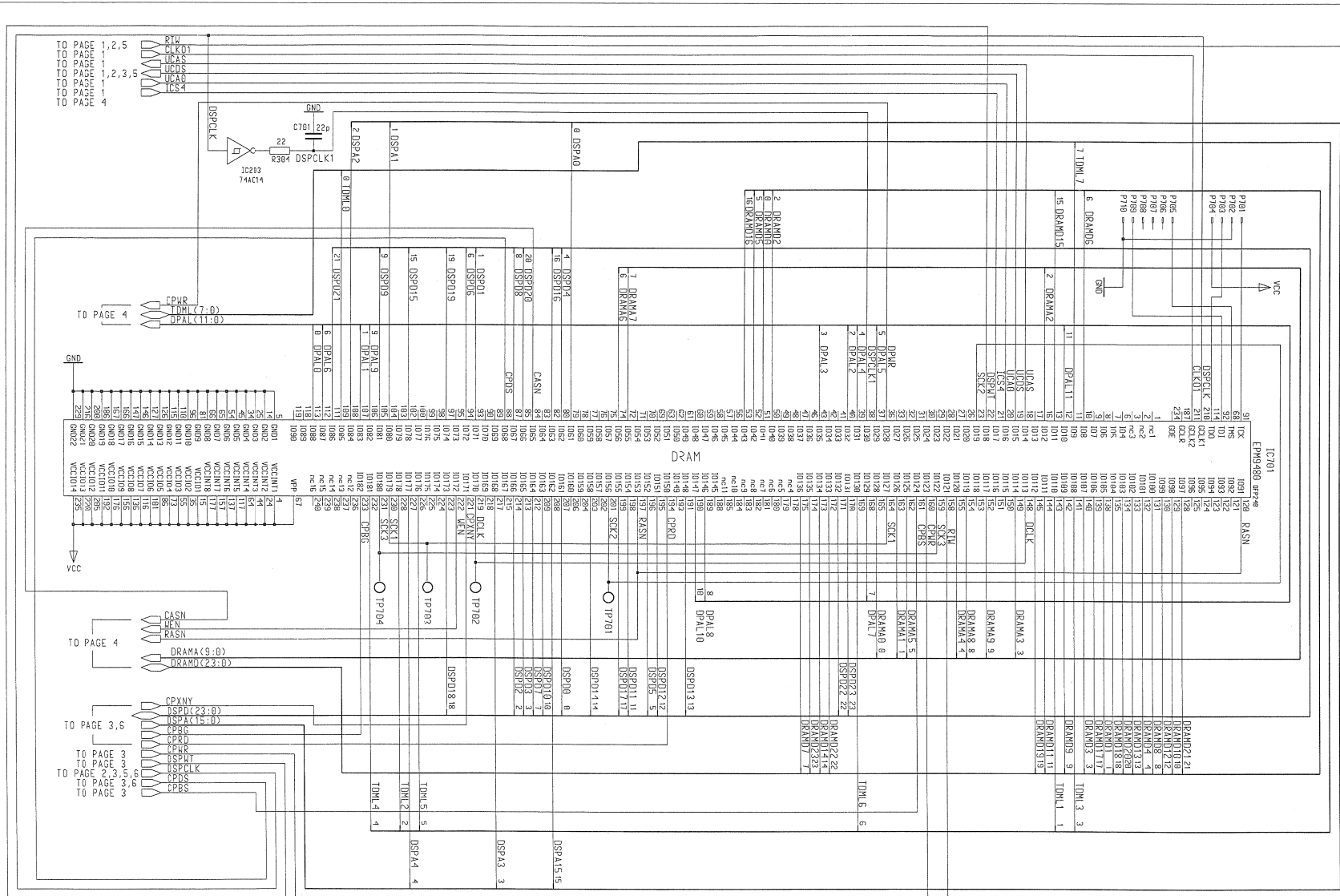



SCSI Core 1.866.130.26

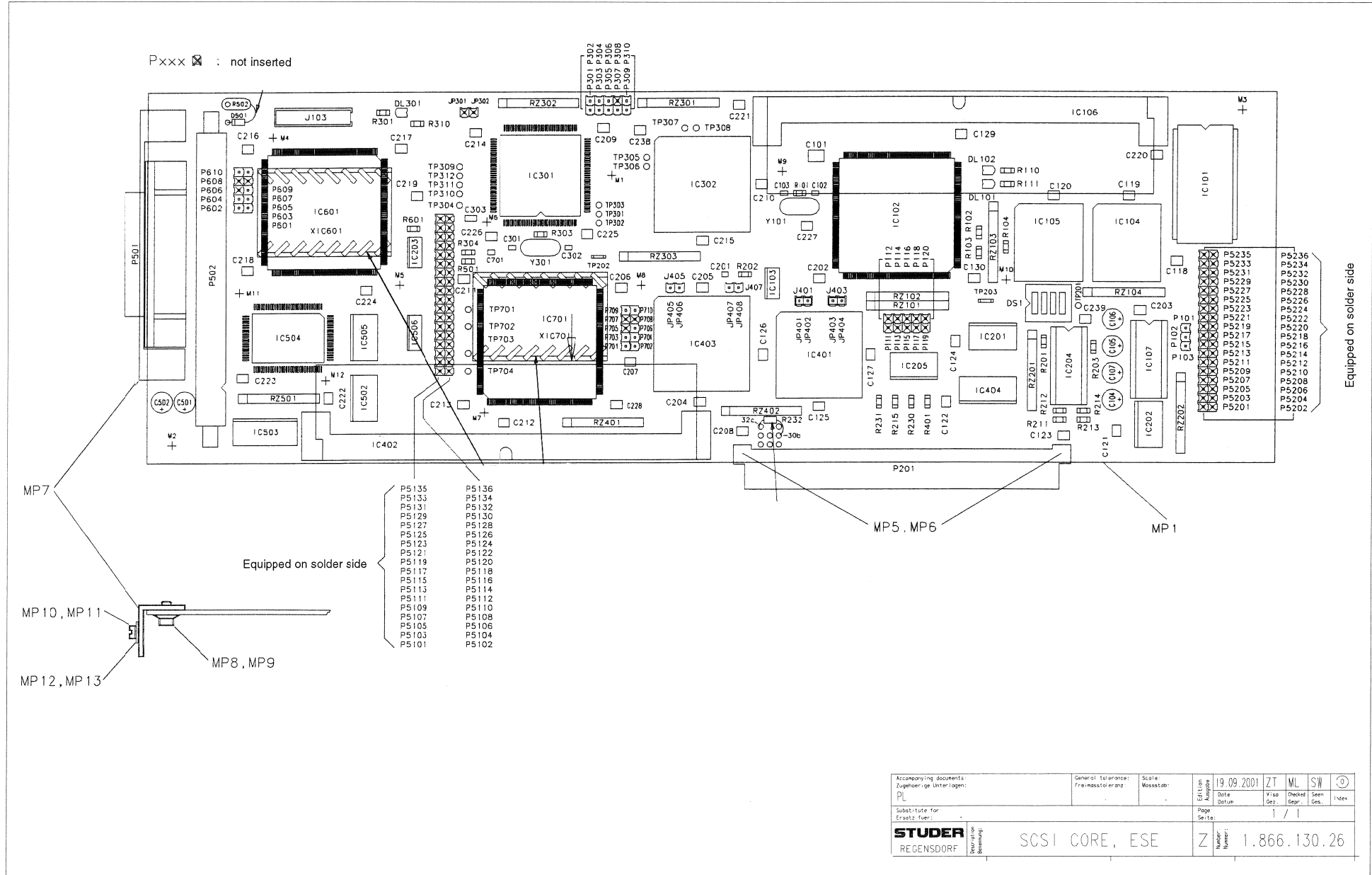



SCSI Core 1.866.130.26

Idx	Pos.	Part No.	Qty.	Type/Val.	Description	Idx	Pos.	Part No.	Qty.	Type/Val.	Description
0	C 101	59.60.1224	220n		CER 63V, 10%, X7R, 1012	0	IC 601	50.63.4204		EPM9480	IC EPM 9480 RC 240-15
0	C 102	59.60.0150	15p		CER 63V, 5%, COG, 0805	0	IC 701	50.63.4204		EPM9480	IC EPM 9480 RC 240-15
0	C 103	59.60.0150	15p		CER 63V, 5%, COG, 0805	0	J 103	54.14.5516		16p	PCB-Buchse gerade
0	C 104	59.22.6100	10u		EL 35V, 20%, RM5	0	J 401	54.01.0021			Jumper 0.63 * 0.63mm
0	C 105	59.22.6100	10u		EL 35V, 20%, RM5	0	J 403	54.01.0021			Jumper 0.63 * 0.63mm
0	C 106	59.22.6100	10u		EL 35V, 20%, RM5	0	J 405	not used			Jumper 0.63 * 0.63mm
0	C 107	59.22.6100	10u		EL 35V, 20%, RM5	0	J 407	not used			Jumper 0.63 * 0.63mm
0	C 118	59.60.1104	100n		CER 63V, 10%, X7R, 1210	0	JP 301	not used		1p	Pin 0.63*0.63
0	C 119	59.60.1104	100n		CER 63V, 10%, X7R, 1210	0	JP 302	not used		1p	Pin 0.63*0.63
0	C 120	59.60.1104	100n		CER 63V, 10%, X7R, 1210	0	JP 401	54.01.0020		1p	Pin 0.63*0.63
0	C 121	59.60.1104	100n		CER 63V, 10%, X7R, 1210	0	JP 402	54.01.0020		1p	Pin 0.63*0.63
0	C 122	59.60.1104	100n		CER 63V, 10%, X7R, 1210	0	JP 403	54.01.0020		1p	Pin 0.63*0.63
0	C 123	59.60.1104	100n		CER 63V, 10%, X7R, 1210	0	JP 404	54.01.0020		1p	Pin 0.63*0.63
0	C 124	59.60.1104	100n		CER 63V, 10%, X7R, 1210	0	JP 405	54.01.0020		1p	Pin 0.63*0.63
0	C 125	59.60.1104	100n		CER 63V, 10%, X7R, 1210	0	JP 406	54.01.0020		1p	Pin 0.63*0.63
0	C 126	59.60.1104	100n		CER 63V, 10%, X7R, 1210	0	JP 407	54.01.0020		1p	Pin 0.63*0.63
0	C 127	59.60.1104	100n		CER 63V, 10%, X7R, 1210	0	MP 1	1.866.130.12	1 pce		SCSI CORE PCB
0	C 129	59.60.1104	100n		CER 63V, 10%, X7R, 1210	0	MP 2	43.01.0108	1 pce	Label	ESE-WARNschild
0	C 130	59.60.1104	100n		CER 63V, 10%, X7R, 1210	0	MP 3	1.101.001.26			TEXT-ETIK. 5*20 HARDWARE -26
0	C 201	59.60.0330	33p		CER 63V, 5%, COG, 0805	0	MP 4	1.866.130.10	1 pce		NR. LABEL
0	C 202	59.60.1104	100n		CER 63V, 10%, X7R, 1210	0	MP 5	28.99.0119	1 pce		ROHRNIETE D 2.5*0.15* 9
0	C 203	59.60.1104	100n		CER 63V, 10%, X7R, 1210	0	MP 6	28.99.0119	1 pce		ROHRNIETE D 2.5*0.15* 9
0	C 204	59.60.1104	100n		CER 63V, 10%, X7R, 1210	0	MP 7	1.866.130.01			SCSI PANELBLECH
0	C 205	59.60.1104	100n		CER 63V, 10%, X7R, 1210	0	MP 8	21.53.9354		M3*6	Z-Schraube Inbus-Ripp Zn gb ch
0	C 206	59.60.1104	100n		CER 63V, 10%, X7R, 1210	0	MP 9	21.53.9354		M3*6	Z-Schraube Inbus-Ripp Zn gb ch
0	C 207	59.60.1104	100n		CER 63V, 10%, X7R, 1210	0	MP 10	21.01.0203		M2*5	Z - Schraube Zn gb chr
0	C 208	59.60.1104	100n		CER 63V, 10%, X7R, 1210	0	MP 11	21.01.0203		M2*5	Z - Schraube Zn gb chr
0	C 209	59.60.1104	100n		CER 63V, 10%, X7R, 1210	0	MP 12	24.16.1020		2.2/4.0	Rippenscheibe
0	C 210	59.60.1104	100n		CER 63V, 10%, X7R, 1210	0	MP 13	24.16.1020		2.2/4.0	Rippenscheibe
0	C 211	59.60.1104	100n		CER 63V, 10%, X7R, 1210	0	MP 601	1.866.903.01			NR. LABEL
0	C 212	59.60.1104	100n		CER 63V, 10%, X7R, 1210	0	MP 701	1.866.902.01			NR. LABEL
0	C 216	59.60.1104	100n		CER 63V, 10%, X7R, 1210	0	P 101	54.01.0020		1p	Pin 0.63*0.63
0	C 217	59.60.1104	100n		CER 63V, 10%, X7R, 1210	0	P 102	54.01.0020		1p	Pin 0.63*0.63
0	C 218	59.60.1104	100n		CER 63V, 10%, X7R, 1210	0	P 103	54.01.0020		1p	Pin 0.63*0.63
0	C 219	59.60.1104	100n		CER 63V, 10%, X7R, 1210	0	P 111	not used		1p	Pin 0.63*0.63
0	C 220	59.60.1104	100n		CER 63V, 10%, X7R, 1210	0	P 112	not used		1p	Pin 0.63*0.63
0	C 221	59.60.1104	100n		CER 63V, 10%, X7R, 1210	0	P 113	not used		1p	Pin 0.63*0.63
0	C 222	59.60.1104	100n		CER 63V, 10%, X7R, 1210	0	P 114	not used		1p	Pin 0.63*0.63
0	C 223	59.60.1104	100n		CER 63V, 10%, X7R, 1210	0	P 115	not used		1p	Pin 0.63*0.63
0	C 224	59.60.1104	100n		CER 63V, 10%, X7R, 1210	0	P 116	not used		1p	Pin 0.63*0.63
0	C 225	59.60.1104	100n		CER 63V, 10%, X7R, 1210	0	P 117	not used		1p	Pin 0.63*0.63
0	C 226	59.60.1104	100n		CER 63V, 10%, X7R, 1210	0	P 118	not used		1p	Pin 0.63*0.63
0	C 227	59.60.1104	100n		CER 63V, 10%, X7R, 1210	0	P 119	not used		1p	Pin 0.63*0.63
0	C 228	59.60.1104	100n		CER 63V, 10%, X7R, 1210	0	P 120	not used		1p	Pin 0.63*0.63
0	C 238	59.60.1104	100n		CER 63V, 10%, X7R, 1210	0	P 201	54.01.0358		96p	EU-C 3 * 32
0	C 239	59.60.1104	100n		CER 63V, 10%, X7R, 1210	0	P 301	54.01.0020		1p	Pin 0.63*0.63
0	C 301	59.60.0220	22p		CER 63V, 5%, COG, 0805	0	P 302	54.01.0020		1p	Pin 0.63*0.63
0	C 302	59.60.0220	22p		CER 63V, 5%, COG, 0805	0	P 303	54.01.0020		1p	Pin 0.63*0.63
0	C 303	59.60.0391	390p		CER 63V, 5%, COG, 1206	0	P 304	54.01.0020		1p	Pin 0.63*0.63
0	C 501	59.22.8229	2u2		EL 50V, 20%, RM5	0	P 305	54.01.0020		1p	Pin 0.63*0.63
0	C 502	59.22.6100	10u		EL 35V, 20%, RM5	0	P 306	54.01.0020		1p	Pin 0.63*0.63
0	C 701	59.60.0220	22p		CER 63V, 5%, COG, 0805	0	P 307	not used		1p	Pin 0.63*0.63
0	D 501	50.04.0133	BAV20		D BAV 20 SI	0	P 308	54.01.0020		1p	Pin 0.63*0.63
0	DL 101	50.04.2121	TLUR 2401		DL TLUR 2401 RT MATT	0	P 309	54.01.0020		1p	Pin 0.63*0.63
0	DL 102	50.04.2121	TLUR 2401		DL TLUR 2401 RT MATT	0	P 310	54.01.0020		1p	Pin 0.63*0.63
0	DL 301	50.04.2121	TLUR 2401		DL TLUR 2401 RT MATT	0	P 501	54.13.8105		50p	Connector female for SCSI-2
0	DS 1	55.01.0164	4*a		SZ 4*A, DIL	0	P 502	54.14.2055		50p	P STECKER 50 P , AU, GRADE
0	IC 101	50.16.0801	DS12887		Real Time Clock	0	P 601	54.01.0020		1p	Pin 0.63*0.63
0	IC 102	50.63.0201	68EN360		Communication Controller	0	P 602	54.01.0020		1p	Pin 0.63*0.63
0	IC 103	50.62.5014	74AC 14		Hex inverting Schmitt trigger	0	P 603	54.01.0020		1p	Pin 0.63*0.63
0	IC 104	1.866.901.25	SW130		SW130 MAIN HIGH (50.63.1301)	0	P 604	54.01.0020		1p	Pin 0.63*0.63
0	IC 105	1.866.900.25	SW130		SW130 MAIN LOW (50.63.1301)	0	P 605	54.01.0020		1p	Pin 0.63*0.63
0	IC 106	50.63.1651	256K*32		DRAM 256K*32, SIMM 72	0	P 606	not used		1p	Pin 0.63*0.63
0	IC 107	50.15.0120	MAX232		IC MAX 232 CPE	0	P 607	not used		1p	Pin 0.63*0.63
0	IC 201	50.62.1541	74HC541		Octal buffer line driver/recei	0	P 608	not used		1p	Pin 0.63*0.63
0	IC 202	50.62.1541	74HC541		Octal buffer line driver/recei	0	P 609	54.01.0020		1p	Pin 0.63*0.63
0	IC 203	50.62.5014	74AC 14		Hex inverting Schmitt trigger	0	P 610	54.01.0020		1p	Pin 0.63*0.63
0	IC 204	50.15.0128	34C86		IC DS 34 C 86 TN, MC34C86P ,A	0	P 701	54.01.0020		1p	Pin 0.63*0.63
0	IC 205	50.62.3245	74HCT245		Octal bus transceiver	0	P 702	54.01.0020		1p	Pin 0.63*0.63
0	IC 301	50.63.0406	DSP56002		DSP 56 002 40MHz	0	P 703	54.01.0020		1p	Pin 0.63*0.63
0	IC 302	50.63.1524	56824		SRAM 8K* 24	0	P 704	54.01.0020		1p	Pin 0.63*0.63
0	IC 401	1.866.907.20	SW130		SW130 TDMCON (50.63.4202)	0	P 705	54.01.0020		1p	Pin 0.63*0.63
0	IC 402	50.63.1652	1M*32		DRAM 1M*32, SIMM 72	0	P 706	not used		1p	Pin 0.63*0.63
0	IC 403	50.63.1703	7130		Dualport SRAM, 1K*8	0	P 707	not used		1p	Pin 0.63*0.63
0	IC 404	50.62.6652	74ABT652		Octal transceiver register	0	P 708	not used		1p	Pin 0.63*0.63
0	IC 502	50.62.6645	74ACT645		Octal bus transceiver	0	P 709	54.01.0020		1p	Pin 0.63*0.63
0	IC 503	50.62.0401	UC5602		SCSI active terminator	0	P 710	54.01.0020		1p	Pin 0.63*0.63
0	IC 504	50.63.0202	53CF96-2		SCSI Controller	0	P 5101	not used		1p	P STIFT, 12,7 MM 1 PIN=1 STK.
0	IC 505	50.62.6645	74ACT645		Octal bus transceiver	0	P 5102	not used		1p	P STIFT, 12,7 MM 1 PIN=1 STK.
0	IC 506	50.62.6138	74ACT138		3 to 8 line decoder	0	P 5103	not used		1p	P STIFT, 12,7 MM 1 PIN=1 STK.
						0	P 5104	not used		1p	P STIFT, 12,7 MM 1 PIN=1 STK.
						0	P 5105	not used		1p	P STIFT, 12,7 MM 1 PIN=1 STK.



SCSI Core 1.866.130.26

Idx	Pos.	Part No.	Qty.	Type/Val.	Description	Idx	Pos.	Part No.	Qty.	Type/Val.	Description
0	P 5106	not used	1p	P	STIFT,12,7 MM 1 PIN=1 STK.	0	R 304	57.60.1220	22R	MF, 1%, 0204, E24	
0	P 5107	not used	1p	P	STIFT,12,7 MM 1 PIN=1 STK.	0	R 310	57.60.1471	470R	MF, 1%, 0204, E24	
0	P 5108	not used	1p	P	STIFT,12,7 MM 1 PIN=1 STK.	0	R 401	57.60.1102	1K	MF, 1%, 0204, E24	
0	P 5109	not used	1p	P	STIFT,12,7 MM 1 PIN=1 STK.	0	R 501	57.60.1330	33R	MF, 1%, 0204, E24	
0	P 5110	not used	1p	P	STIFT,12,7 MM 1 PIN=1 STK.	0	R 502	57.92.7013	0.5A	POLY- PTC, 60V	
0	P 5111	not used	1p	P	STIFT,12,7 MM 1 PIN=1 STK.	0	R 601	57.60.1103	10K	MF, 1%, 0204, E24	
0	P 5112	not used	1p	P	STIFT,12,7 MM 1 PIN=1 STK.	0	RZ 101	57.88.4103	8*10k	2%, SIP 9	
0	P 5113	not used	1p	P	STIFT,12,7 MM 1 PIN=1 STK.	0	RZ 102	57.88.4103	8*10k	2%, SIP 9	
0	P 5114	not used	1p	P	STIFT,12,7 MM 1 PIN=1 STK.	0	RZ 103	57.88.4103	8*10k	2%, SIP 9	
0	P 5115	not used	1p	P	STIFT,12,7 MM 1 PIN=1 STK.	0	RZ 104	57.88.4103	8*10k	2%, SIP 9	
0	P 5116	not used	1p	P	STIFT,12,7 MM 1 PIN=1 STK.	0	RZ 201	57.88.4222	8*2k2	2%, SIP 9	
0	P 5117	not used	1p	P	STIFT,12,7 MM 1 PIN=1 STK.	0	RZ 202	57.88.4103	8*10k	2%, SIP 9	
0	P 5118	not used	1p	P	STIFT,12,7 MM 1 PIN=1 STK.	0	RZ 301	57.88.4103	8*10k	2%, SIP 9	
0	P 5119	not used	1p	P	STIFT,12,7 MM 1 PIN=1 STK.	0	RZ 302	57.88.4103	8*10k	2%, SIP 9	
0	P 5120	not used	1p	P	STIFT,12,7 MM 1 PIN=1 STK.	0	RZ 303	57.88.4103	8*10k	2%, SIP 9	
0	P 5121	not used	1p	P	STIFT,12,7 MM 1 PIN=1 STK.	0	RZ 401	57.88.4103	8*10k	2%, SIP 9	
0	P 5122	not used	1p	P	STIFT,12,7 MM 1 PIN=1 STK.	0	RZ 402	57.88.4103	8*10k	2%, SIP 9	
0	P 5123	not used	1p	P	STIFT,12,7 MM 1 PIN=1 STK.	0	RZ 501	57.88.4222	8*2k2	2%, SIP 9	
0	P 5124	not used	1p	P	STIFT,12,7 MM 1 PIN=1 STK.	0	TP 202	54.02.0320	1p	Flatpin, 2,8*0.8mm	
0	P 5125	not used	1p	P	STIFT,12,7 MM 1 PIN=1 STK.	0	TP 203	54.02.0320	1p	Flatpin, 2,8*0.8mm	
0	P 5126	not used	1p	P	STIFT,12,7 MM 1 PIN=1 STK.	0	XIC 101	53.03.0182	24p	DIL 0.3", lötl, gerade	
0	P 5127	not used	1p	P	STIFT,12,7 MM 1 PIN=1 STK.	0	XIC 104	53.03.2232	PLCC32p	PLCC-Socket 32p	
0	P 5128	not used	1p	P	STIFT,12,7 MM 1 PIN=1 STK.	0	XIC 105	53.03.2232	PLCC32p	PLCC-Socket 32p	
0	P 5129	not used	1p	P	STIFT,12,7 MM 1 PIN=1 STK.	0	XIC 106	54.10.3772	72p	SIMM-Socket 72p	
0	P 5130	not used	1p	P	STIFT,12,7 MM 1 PIN=1 STK.	0	XIC 107	53.03.0166	16p	DIL 0.3", lötl, gerade	
0	P 5131	not used	1p	P	STIFT,12,7 MM 1 PIN=1 STK.	0	XIC 204	53.03.0168	16p	DIL 0.3", lötl, gerade	
0	P 5132	not used	1p	P	STIFT,12,7 MM 1 PIN=1 STK.	0	XIC 302	53.03.2252	52p	PLCC-Socket	
0	P 5133	not used	1p	P	STIFT,12,7 MM 1 PIN=1 STK.	0	XIC 401	53.03.2244	44p	PLCC-Socket	
0	P 5134	not used	1p	P	STIFT,12,7 MM 1 PIN=1 STK.	0	XIC 402	54.10.3772	72p	SIMM-Socket 72p	
0	P 5135	not used	1p	P	STIFT,12,7 MM 1 PIN=1 STK.	0	XIC 403	53.03.2252	52p	PLCC-Socket	
0	P 5136	not used	1p	P	STIFT,12,7 MM 1 PIN=1 STK.	0	XIC 601	50.20.3013		Kühlkörper, TO 220	
0	P 5201	not used	1p	P	STIFT,12,7 MM 1 PIN=1 STK.	0	XIC 701	50.20.3013		Kühlkörper, TO 220	
0	P 5202	not used	1p	P	STIFT,12,7 MM 1 PIN=1 STK.	0	Y 101	89.01.0552	3.0720MHz	XTAL HC 18 U	
0	P 5203	not used	1p	P	STIFT,12,7 MM 1 PIN=1 STK.	0	Y 301	89.01.1007	20.000MHz	XTAL HC 49/U	
0	P 5204	not used	1p	P	STIFT,12,7 MM 1 PIN=1 STK.						
0	P 5205	not used	1p	P	STIFT,12,7 MM 1 PIN=1 STK.						
0	P 5206	not used	1p	P	STIFT,12,7 MM 1 PIN=1 STK.						
0	P 5207	not used	1p	P	STIFT,12,7 MM 1 PIN=1 STK.						
0	P 5208	not used	1p	P	STIFT,12,7 MM 1 PIN=1 STK.						
0	P 5209	not used	1p	P	STIFT,12,7 MM 1 PIN=1 STK.						
0	P 5210	not used	1p	P	STIFT,12,7 MM 1 PIN=1 STK.						
0	P 5211	not used	1p	P	STIFT,12,7 MM 1 PIN=1 STK.						
0	P 5212	not used	1p	P	STIFT,12,7 MM 1 PIN=1 STK.						
0	P 5213	not used	1p	P	STIFT,12,7 MM 1 PIN=1 STK.						
0	P 5214	not used	1p	P	STIFT,12,7 MM 1 PIN=1 STK.						
0	P 5215	not used	1p	P	STIFT,12,7 MM 1 PIN=1 STK.						
0	P 5216	not used	1p	P	STIFT,12,7 MM 1 PIN=1 STK.						
0	P 5217	not used	1p	P	STIFT,12,7 MM 1 PIN=1 STK.						
0	P 5218	not used	1p	P	STIFT,12,7 MM 1 PIN=1 STK.						
0	P 5219	not used	1p	P	STIFT,12,7 MM 1 PIN=1 STK.						
0	P 5220	not used	1p	P	STIFT,12,7 MM 1 PIN=1 STK.						
0	P 5221	not used	1p	P	STIFT,12,7 MM 1 PIN=1 STK.						
0	P 5222	not used	1p	P	STIFT,12,7 MM 1 PIN=1 STK.						
0	P 5223	not used	1p	P	STIFT,12,7 MM 1 PIN=1 STK.						
0	P 5224	not used	1p	P	STIFT,12,7 MM 1 PIN=1 STK.						
0	P 5225	not used	1p	P	STIFT,12,7 MM 1 PIN=1 STK.						
0	P 5226	not used	1p	P	STIFT,12,7 MM 1 PIN=1 STK.						
0	P 5227	not used	1p	P	STIFT,12,7 MM 1 PIN=1 STK.						
0	P 5228	not used	1p	P	STIFT,12,7 MM 1 PIN=1 STK.						
0	P 5229	not used	1p	P	STIFT,12,7 MM 1 PIN=1 STK.						
0	P 5230	not used	1p	P	STIFT,12,7 MM 1 PIN=1 STK.						
0	P 5231	not used	1p	P	STIFT,12,7 MM 1 PIN=1 STK.						
0	P 5232	not used	1p	P	STIFT,12,7 MM 1 PIN=1 STK.						
0	P 5233	not used	1p	P	STIFT,12,7 MM 1 PIN=1 STK.						
0	P 5234	not used	1p	P	STIFT,12,7 MM 1 PIN=1 STK.						
0	P 5235	not used	1p	P	STIFT,12,7 MM 1 PIN=1 STK.						
0	P 5236	not used	1p	P	STIFT,12,7 MM 1 PIN=1 STK.						
0	R 101	57.60.1106	10M	MF, 2%, 0204, E24							
0	R 102	57.60.1103	10K	MF, 1%, 0204, E24							
0	R 103	57.60.1103	10K	MF, 1%, 0204, E24							
0	R 104	57.60.1103	10K	MF, 1%, 0204, E24							
0	R 110	57.60.1471	470R	MF, 1%, 0204, E24							
0	R 111	57.60.1471	470R	MF, 1%, 0204, E24							
0	R 201	57.60.1221	220R	MF, 1%, 0204, E24							
0	R 202	57.60.1151	150R	MF, 1%, 0204, E24							
0	R 203	57.60.1221	220R	MF, 1%, 0204, E24							
0	R 211	57.60.1103	10K	MF, 1%, 0204, E24							
0	R 212	57.60.1103	10K	MF, 1%, 0204, E24							
0	R 213	57.60.1103	10K	MF, 1%, 0204, E24							
0	R 214	57.60.1103	10K	MF, 1%, 0204, E24							
0	R 215	57.60.1330	33R	MF, 1%, 0204, E24							
0	R 230	57.60.1103	10K	MF, 1%, 0204, E24							
0	R 231	57.60.1103	10K	MF, 1%, 0204, E24							
0	R 232	57.10.1272	2k7	MF, 1%, 0204							
0	R 301	57.60.1471	470R	MF, 1%, 0204, E24							
0	R 303	57.60.1684	680K	MF, 1%, 0204, E24							

End of List

Comments:

- (25) Software Update
- (26) Software Update
- Zusätzlich XIC601, XIC701

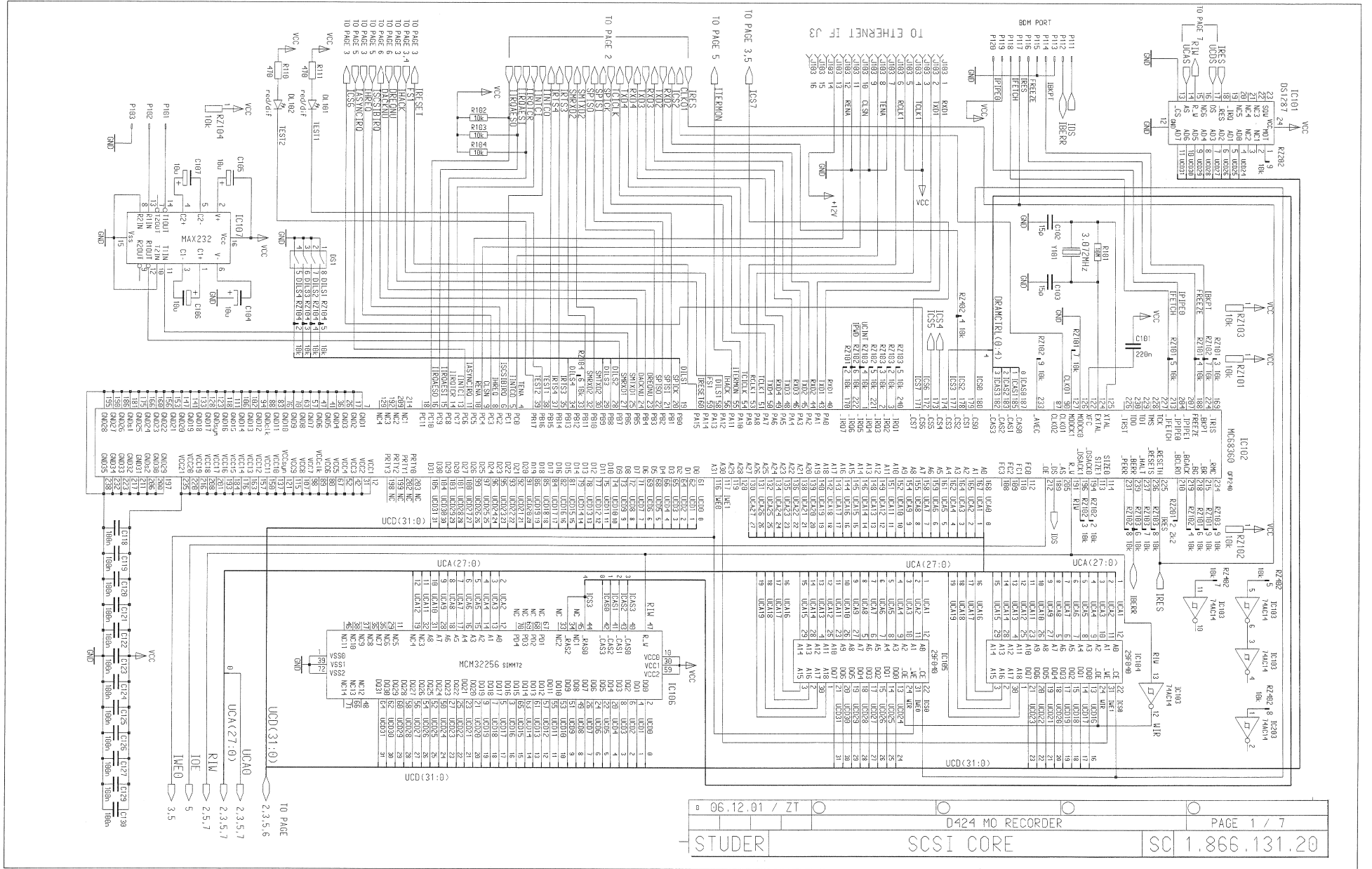

SCSI Core 1.866.131.20

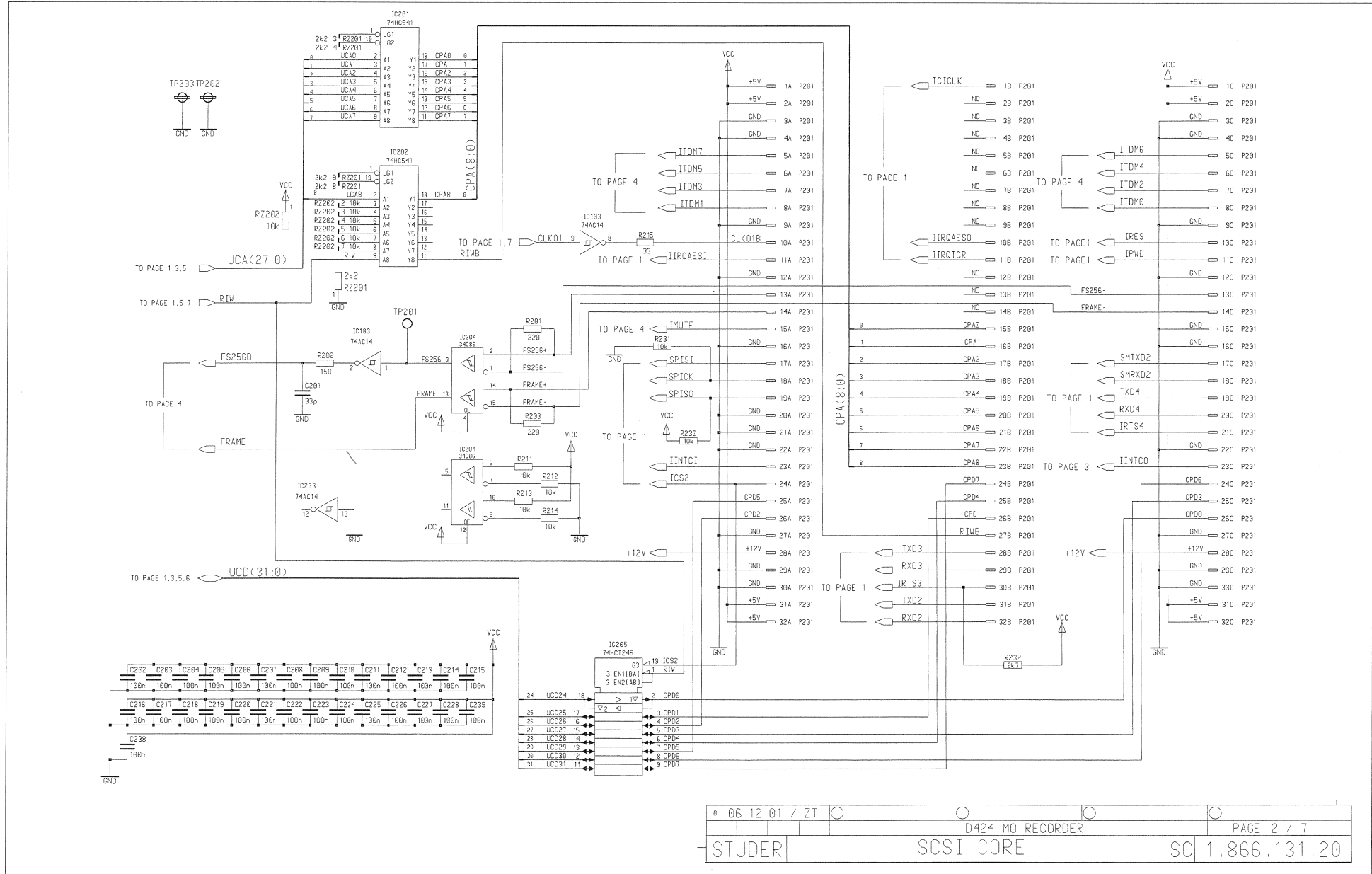







SCSI Core 1.866.131.20

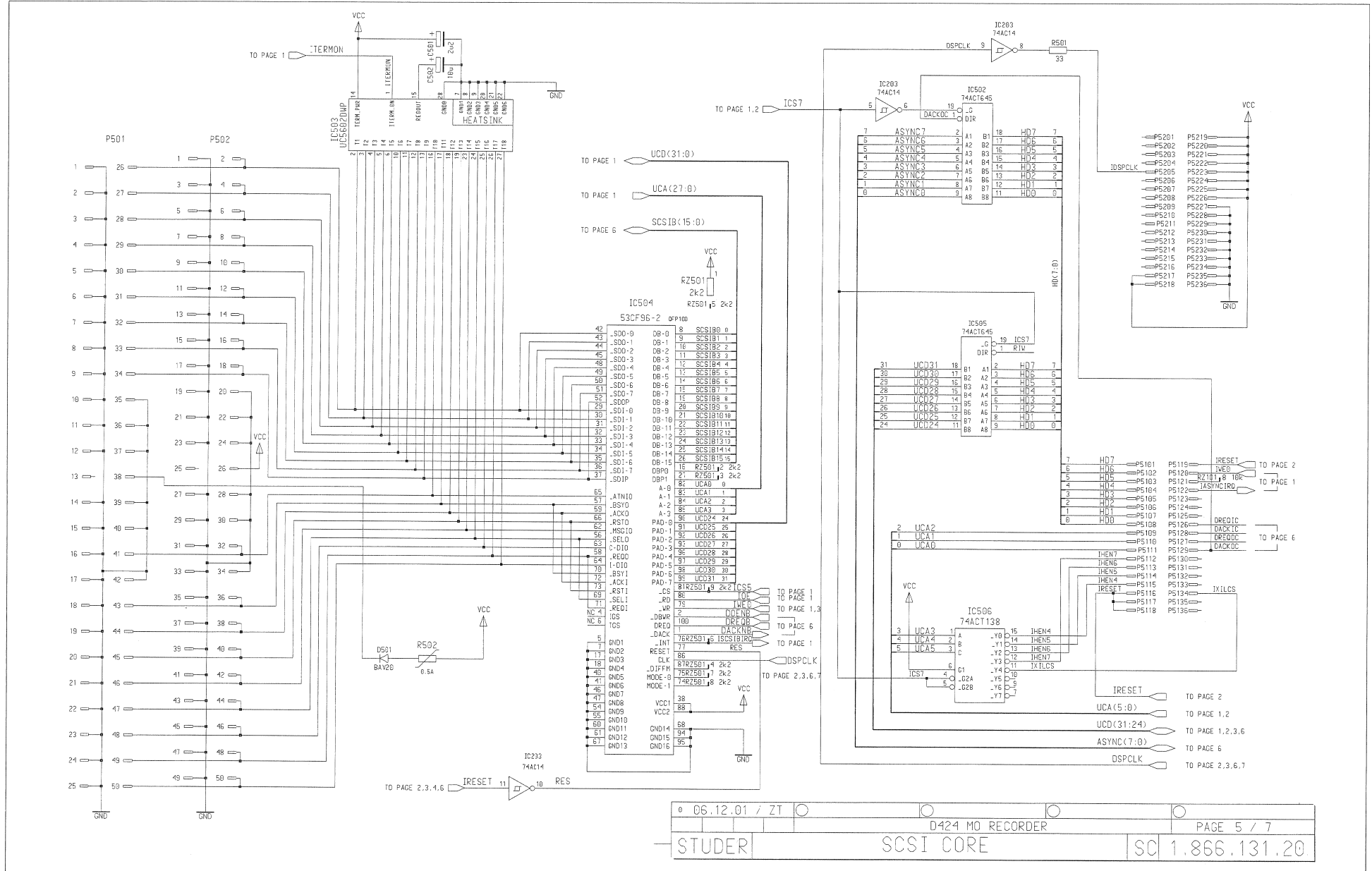





SCSI Core 1.866.131.20

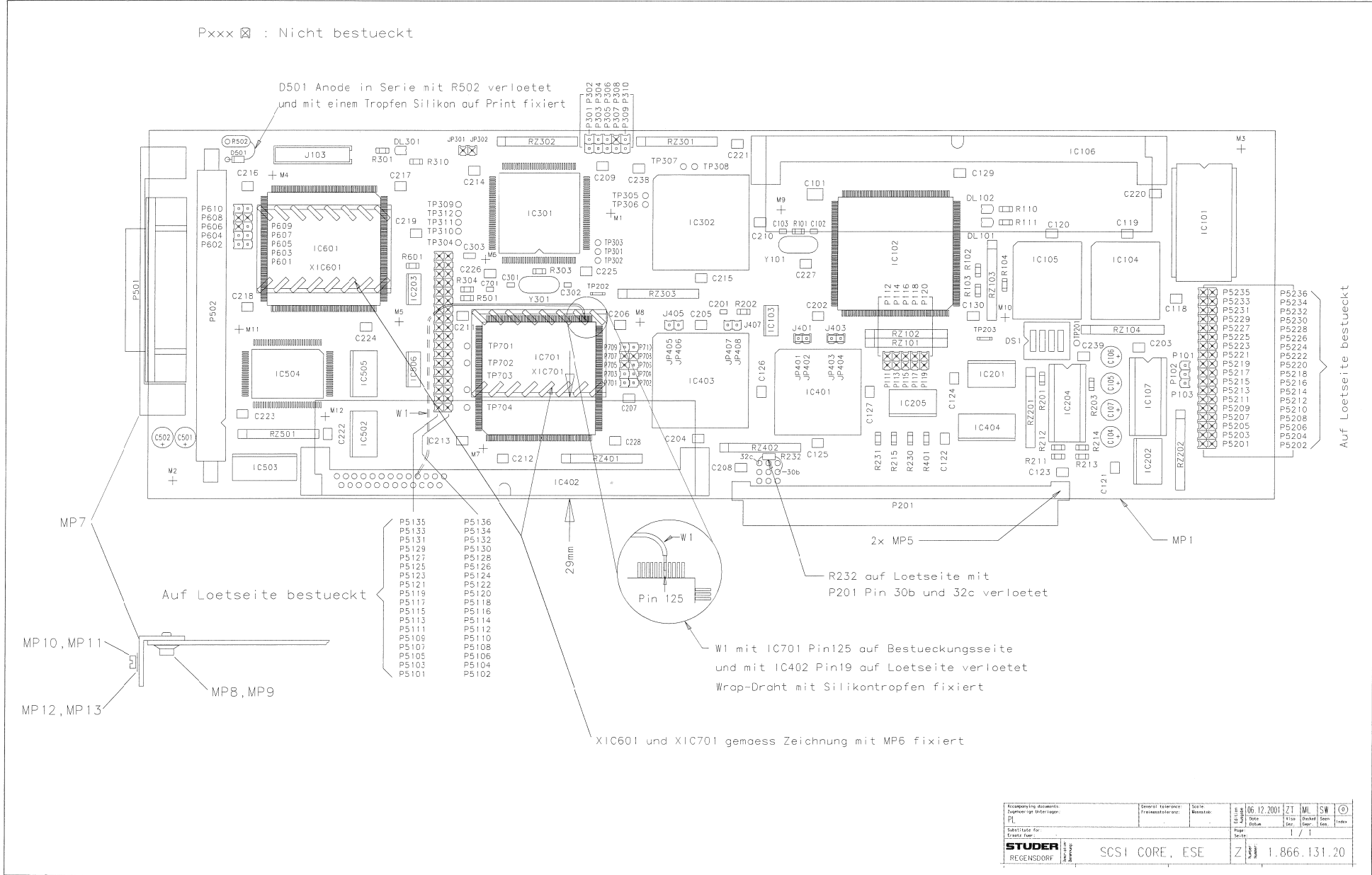

## SCSI Core 1.866.131.20

Idx	Pos.	Part No.	Qty.	Type/Val.	Description	Idx	Pos.	Part No.	Qty.	Type/Val.	Description
0	C 101	59.60.3741		220n	CER 50V, 10%, X7R, 1812	0	IC 503	50.62.0401		UC5602	SCSI active terminator
0	C 102	59.60.2329		15p	CER 50V, 5%, C0G, 0805	0	IC 504	50.63.0202		53CF98-2	SCSI Controller
0	C 103	59.60.2329		15p	CER 50V, 5%, C0G, 0805	0	IC 505	50.62.6645		74ACT645	Octal bus transceiver
0	C 104	59.22.6100		10u	EL 35V 20% RM5	0	IC 506	50.62.6138		74ACT138	3 to 8 line decoder
0	C 105	59.22.6100		10u	EL 35V 20% RM5	0	IC 601	60.63.4204		EPM0480	EPLD 10000 QFP240
0	C 106	59.22.6100		10u	EL 35V 20% RM5	0	IC 701	50.63.4204		EPM9480	EPLD 10000 QFP240
0	C 107	59.22.6100		10u	EL 35V 20% RM5						
0	C 118	59.60.3537		100n	CER 50V, 10%, X7R, 1210	0	J 103	54.14.5516		16p	PCB-Buchse gerade
0	C 119	59.60.3537		100n	CER 50V, 10%, X7R, 1210	0	J 401	54.01.0021		Jumper	0.63*0.63mm, Au
0	C 120	59.60.3537		100n	CER 50V, 10%, X7R, 1210	0	J 403	54.01.0021		Jumper	0.63*0.63mm, Au
0	C 121	59.60.3537		100n	CER 50V, 10%, X7R, 1210	0	J 405	not used		Jumper	0.63*0.63mm, Au
0	C 122	59.60.3537		100n	CER 50V, 10%, X7R, 1210	0	J 407	not used		Jumper	0.63*0.63mm, Au
0	C 123	59.60.3537		100n	CER 50V, 10%, X7R, 1210	0	JP 301	not used		1p	Pin, 1reihtig, gerade
0	C 124	59.60.3537		100n	CER 50V, 10%, X7R, 1210	0	JP 302	not used		1p	Pin, 1reihtig, gerade
0	C 125	59.60.3537		100n	CER 50V, 10%, X7R, 1210	0	JP 401	54.01.0020		1p	Pin, 1reihtig, gerade
0	C 126	59.60.3537		100n	CER 50V, 10%, X7R, 1210	0	JP 402	54.01.0020		1p	Pin, 1reihtig, gerade
0	C 127	59.60.3537		100n	CER 50V, 10%, X7R, 1210	0	JP 403	54.01.0020		1p	Pin, 1reihtig, gerade
0	C 129	59.60.3537		100n	CER 50V, 10%, X7R, 1210	0	JP 404	54.01.0020		1p	Pin, 1reihtig, gerade
0	C 130	59.60.3537		100n	CER 50V, 10%, X7R, 1210	0	JP 405	54.01.0020		1p	Pin, 1reihtig, gerade
0	C 201	59.60.2337		33p	CER 50V, 5%, C0G, 0805	0	JP 406	54.01.0020		1p	Pin, 1reihtig, gerade
0	C 202	59.60.3537		100n	CER 50V, 10%, X7R, 1210	0	JP 407	54.01.0020		1p	Pin, 1reihtig, gerade
0	C 203	59.60.3537		100n	CER 50V, 10%, X7R, 1210	0	JP 408	54.01.0020		1p	Pin, 1reihtig, gerade
0	C 204	59.60.3537		100n	CER 50V, 10%, X7R, 1210						
0	C 205	59.60.3537		100n	CER 50V, 10%, X7R, 1210	0	MP 1	1.866.130.12	1 pce		SCSI CORE PCB
0	C 206	59.60.3537		100n	CER 50V, 10%, X7R, 1210	0	MP 2	43.01.0108	1 pce	Label	ESE-WARNschild
0	C 207	59.60.3537		100n	CER 50V, 10%, X7R, 1210	0	MP 3	1.101.001.20	1 pce	Label	TEXT-ETIK. 5*20 HARDWARE -20
0	C 208	59.60.3537		100n	CER 50V, 10%, X7R, 1210	0	MP 4	1.866.131.10	1 pce		NR. LABEL
0	C 209	59.60.3537		100n	CER 50V, 10%, X7R, 1210	0	MP 5	28.99.0119	2 pce		ROHRIETE D 2.5*0.15* 9
0	C 210	59.60.3537		100n	CER 50V, 10%, X7R, 1210	0	MP 6	99.01.3251			Wärmeleit-Kleber
0	C 211	59.60.3537		100n	CER 50V, 10%, X7R, 1210	0	MP 7	1.866.130.01			SCSI PANELBLECH
0	C 212	59.60.3537		100n	CER 50V, 10%, X7R, 1210	0	MP 8	21.53.9354		M3*6	Z-Schraube Inbus-Ripp Zn gb ch
0	C 213	59.60.3537		100n	CER 50V, 10%, X7R, 1210	0	MP 9	21.53.9354		M3*6	Z-Schraube Inbus-Ripp Zn gb ch
0	C 214	59.60.3537		100n	CER 50V, 10%, X7R, 1210	0	MP 10	21.01.0203		M2*5	Z - Schraube Zn gb chr
0	C 215	59.60.3537		100n	CER 50V, 10%, X7R, 1210	0	MP 11	21.01.0203		M2*5	Z - Schraube Zn gb chr
0	C 216	59.60.3537		100n	CER 50V, 10%, X7R, 1210	0	MP 12	24.16.1020		2.2/4.0	Rippenscheibe
0	C 217	59.60.3537		100n	CER 50V, 10%, X7R, 1210	0	MP 13	24.16.1020		2.2/4.0	Rippenscheibe
0	C 218	59.60.3537		100n	CER 50V, 10%, X7R, 1210	0	MP 601	1.866.903.01			NR. LABEL
0	C 219	59.60.3537		100n	CER 50V, 10%, X7R, 1210	0	MP 701	1.866.902.01			NR. LABEL
0	C 220	59.60.3537		100n	CER 50V, 10%, X7R, 1210	0	P 101	54.01.0020		1p	Pin, 1reihtig, gerade
0	C 221	59.60.3537		100n	CER 50V, 10%, X7R, 1210	0	P 102	54.01.0020		1p	Pin, 1reihtig, gerade
0	C 222	59.60.3537		100n	CER 50V, 10%, X7R, 1210	0	P 103	54.01.0020		1p	Pin, 1reihtig, gerade
0	C 223	59.60.3537		100n	CER 50V, 10%, X7R, 1210	0	P 111	not used		1p	Pin, 1reihtig, gerade
0	C 224	59.60.3537		100n	CER 50V, 10%, X7R, 1210	0	P 112	not used		1p	Pin, 1reihtig, gerade
0	C 225	59.60.3537		100n	CER 50V, 10%, X7R, 1210	0	P 113	not used		1p	Pin, 1reihtig, gerade
0	C 226	59.60.3537		100n	CER 50V, 10%, X7R, 1210	0	P 114	not used		1p	Pin, 1reihtig, gerade
0	C 227	59.60.3537		100n	CER 50V, 10%, X7R, 1210	0	P 115	not used		1p	Pin, 1reihtig, gerade
0	C 228	59.60.3537		100n	CER 50V, 10%, X7R, 1210	0	P 116	not used		1p	Pin, 1reihtig, gerade
0	C 238	59.60.3537		100n	CER 50V, 10%, X7R, 1210	0	P 117	not used		1p	Pin, 1reihtig, gerade
0	C 239	59.60.3537		100n	CER 50V, 10%, X7R, 1210	0	P 118	not used		1p	Pin, 1reihtig, gerade
0	C 301	59.60.2333		22p	CER 50V, 5%, C0G, 0805	0	P 119	not used		1p	Pin, 1reihtig, gerade
0	C 302	59.60.2333		22p	CER 50V, 5%, C0G, 0805	0	P 120	not used		1p	Pin, 1reihtig, gerade
0	C 303	59.60.2463		390p	CER 50V, 10%, C0G, 1206	0	P 201	54.01.0358		96p	EU-C 3 * 32
0	C 501	59.22.8229		2u2	EL 50V 20% RM5	0	P 301	54.01.0020		1p	Pin, 1reihtig, gerade
0	C 502	59.22.6100		10u	EL 35V 20% RM5	0	P 302	54.01.0020		1p	Pin, 1reihtig, gerade
0	C 701	59.60.2333		22p	CER 50V, 5%, C0G, 0805	0	P 303	54.01.0020		1p	Pin, 1reihtig, gerade
0	D 501	50.04.0133		BAV20	D BAV 20 , SI	0	P 304	54.01.0020		1p	Pin, 1reihtig, gerade
0	DL 101	50.04.2121		TLUR 2401	DL TLUR 2401 RT MATT	0	P 305	54.01.0020		1p	Pin, 1reihtig, gerade
0	DL 102	50.04.2121		TLUR 2401	DL TLUR 2401 RT MATT	0	P 306	54.01.0020		1p	Pin, 1reihtig, gerade
0	DL 301	50.04.2121		TLUR 2401	DL TLUR 2401 RT MATT	0	P 307	not used		1p	Pin, 1reihtig, gerade
0	DS 1	55.01.0164		4*a	SZ , 4*A, DIL	0	P 308	54.01.0020		1p	Pin, 1reihtig, gerade
0	IC 101	50.16.0801		DS12887	Real Time Clock	0	P 309	54.01.0020		1p	Pin, 1reihtig, gerade
0	IC 102	50.63.0201		68EN360	Communication Controller	0	P 310	54.01.0020		1p	Pin, 1reihtig, gerade
0	IC 103	50.62.5014		74AC 14	Hex inverting Schmitt trigger	0	P 501	54.13.8105		50p	Connector female for SCSI-2
0	IC 104	1.866.901.26			SW130 MAIN HIGH (50.63.1301)	0	P 602	54.14.2055		50p	Stecker gerade Au
0	IC 105	1.866.900.26			SW130n MAIN LOW (50.63.1301)	0	P 601	54.01.0020		1p	Pin, 1reihtig, gerade
0	IC 106	50.63.1651		256K*32	DRAM 256K*32, SIMM 72	0	P 602	54.01.0020		1p	Pin, 1reihtig, gerade
0	IC 107	50.15.0120		MAX232	IC MAX 232 CPE	0	P 603	54.01.0020		1p	Pin, 1reihtig, gerade
0	IC 201	50.62.1541		74HC541	Octal buffer line driver/recei	0	P 604	54.01.0020		1p	Pin, 1reihtig, gerade
0	IC 202	50.62.1541		74HC541	Octal buffer line driver/recei	0	P 605	54.01.0020		1p	Pin, 1reihtig, gerade
0	IC 203	50.62.5014		74AC 14	Hex inverting Schmitt trigger	0	P 606	not used		1p	Pin, 1reihtig, gerade
0	IC 204	50.15.0128		34C86	IC DS 34 C 86 TN, MC34C86P_A	0	P 607	not used		1p	Pin, 1reihtig, gerade
0	IC 205	50.62.3245		74HCT245	Octal bus transceiver	0	P 608	not used		1p	Pin, 1reihtig, gerade
0	IC 301	50.63.0406		DSP56002	DSP 56 002 40MHz	0	P 609	54.01.0020		1p	Pin, 1reihtig, gerade
0	IC 302	50.63.1524		56824	SRAM 8K* 24	0	P 610	54.01.0020		1p	Pin, 1reihtig, gerade
0	IC 401	1.866.907.20			SW130 TDMCON (50.63.4202)	0	P 701	54.01.0020		1p	Pin, 1reihtig, gerade
0	IC 402	50.63.1653		4M*32	DRAM 4M*32, SIMM 72	0	P 702	54.01.0020		1p	Pin, 1reihtig, gerade
0	IC 403	50.63.1703		7130	Dualport SRAM, 1K*8	0	P 703	54.01.0020		1p	Pin, 1reihtig, gerade
0	IC 404	50.62.6652		74ABT652	Octal transceiver register	0	P 705	not used		1p	Pin, 1reihtig, gerade
0	IC 502	50.62.6645		74ACT645	Octal bus transceiver	0	P 706	54.01.0020		1p	Pin, 1reihtig, gerade
						0	P 707	not used		1p	Pin, 1reihtig, gerade

## SCSI Core 1.866.131.20

Idx	Pos.	Part No.	Qty.	Type/Val.	Description	Idx	Pos.	Part No.	Qty.	Type/Val.	Description
0	P 708	not used	1p		Pin, 1reihiig, gerade	0	P 5234	not used	1p		Pin, 1reihiig, gerade
0	P 709	54.01.0020	1p		Pin, 1reihiig, gerade	0	P 5235	not used	1p		Pin, 1reihiig, gerade
0	P 710	54.01.0020	1p		Pin, 1reihiig, gerade	0	P 5236	not used	1p		Pin, 1reihiig, gerade
0	P 5101	not used	1p		Pin, 1reihiig, gerade	0	R 101	57.60.1106	10M		MF, 1%, 0204, E24
0	P 5102	not used	1p		Pin, 1reihiig, gerade	0	R 102	57.60.1103	10k		MF, 1%, 0204, E24
0	P 5103	not used	1p		Pin, 1reihiig, gerade	0	R 103	57.60.1103	10k		MF, 1%, 0204, E24
0	P 5104	not used	1p		Pin, 1reihiig, gerade	0	R 104	57.60.1103	10k		MF, 1%, 0204, E24
0	P 5105	not used	1p		Pin, 1reihiig, gerade	0	R 110	57.60.1471	470R		MF, 1%, 0204, E24
0	P 5106	not used	1p		Pin, 1reihiig, gerade	0	R 111	57.60.1471	470R		MF, 1%, 0204, E24
0	P 5107	not used	1p		Pin, 1reihiig, gerade	0	R 201	57.60.1221	220R		MF, 1%, 0204, E24
0	P 5108	not used	1p		Pin, 1reihiig, gerade	0	R 202	57.60.1151	150R		MF, 1%, 0204, E24
0	P 5109	not used	1p		Pin, 1reihiig, gerade	0	R 203	57.60.1221	220R		MF, 1%, 0204, E24
0	P 5110	not used	1p		Pin, 1reihiig, gerade	0	R 211	57.60.1103	10k		MF, 1%, 0204, E24
0	P 5111	not used	1p		Pin, 1reihiig, gerade	0	R 212	57.60.1103	10k		MF, 1%, 0204, E24
0	P 5112	not used	1p		Pin, 1reihiig, gerade	0	R 213	57.60.1103	10k		MF, 1%, 0204, E24
0	P 5113	not used	1p		Pin, 1reihiig, gerade	0	R 214	57.60.1103	10k		MF, 1%, 0204, E24
0	P 5114	not used	1p		Pin, 1reihiig, gerade	0	R 215	57.60.1330	33R		MF, 1%, 0204, E24
0	P 5115	not used	1p		Pin, 1reihiig, gerade	0	R 230	57.60.1103	10k		MF, 1%, 0204, E24
0	P 5116	not used	1p		Pin, 1reihiig, gerade	0	R 231	57.60.1103	10k		MF, 1%, 0204, E24
0	P 5117	not used	1p		Pin, 1reihiig, gerade	0	R 232	57.10.1272	2k7		MF, 1%, 0204
0	P 5118	not used	1p		Pin, 1reihiig, gerade	0	R 301	57.60.1471	470R		MF, 1%, 0204, E24
0	P 5119	not used	1p		Pin, 1reihiig, gerade	0	R 303	57.60.1684	680k		MF, 1%, 0204, E24
0	P 5120	not used	1p		Pin, 1reihiig, gerade	0	R 304	57.60.1220	22R		MF, 1%, 0204, E24
0	P 5121	not used	1p		Pin, 1reihiig, gerade	0	R 310	57.60.1471	470R		MF, 1%, 0204, E24
0	P 5122	not used	1p		Pin, 1reihiig, gerade	0	R 401	57.60.1102	1k0		MF, 1%, 0204, E24
0	P 5123	not used	1p		Pin, 1reihiig, gerade	0	R 501	57.60.1330	33R		MF, 1%, 0204, E24
0	P 5124	not used	1p		Pin, 1reihiig, gerade	0	R 602	57.92.7013	0.5A		PTC 60V
0	P 5125	not used	1p		Pin, 1reihiig, gerade	0	R 601	57.60.1103	10k		MF, 1%, 0204, E24
0	P 5126	not used	1p		Pin, 1reihiig, gerade	0	RZ 101	57.88.4103	10k		8*R Resistor-Netw 2% SIP9
0	P 5127	not used	1p		Pin, 1reihiig, gerade	0	RZ 102	57.88.4103	10k		8*R Resistor-Netw 2% SIP9
0	P 5128	not used	1p		Pin, 1reihiig, gerade	0	RZ 103	57.88.4103	10k		8*R Resistor-Netw 2% SIP9
0	P 5129	not used	1p		Pin, 1reihiig, gerade	0	RZ 104	57.88.4103	10k		8*R Resistor-Netw 2% SIP9
0	P 5130	not used	1p		Pin, 1reihiig, gerade	0	RZ 201	57.88.4222	2k2		8*R Resistor-Netw 2% SIP9
0	P 5131	not used	1p		Pin, 1reihiig, gerade	0	RZ 202	57.88.4103	10k		8*R Resistor-Netw 2% SIP9
0	P 5132	not used	1p		Pin, 1reihiig, gerade	0	RZ 301	57.88.4103	10k		8*R Resistor-Netw 2% SIP9
0	P 5133	not used	1p		Pin, 1reihiig, gerade	0	RZ 302	57.88.4103	10k		8*R Resistor-Netw 2% SIP9
0	P 5134	not used	1p		Pin, 1reihiig, gerade	0	RZ 303	57.88.4103	10k		8*R Resistor-Netw 2% SIP9
0	P 5135	not used	1p		Pin, 1reihiig, gerade	0	RZ 401	57.88.4103	10k		8*R Resistor-Netw 2% SIP9
0	P 5136	not used	1p		Pin, 1reihiig, gerade	0	RZ 402	57.88.4103	10k		8*R Resistor-Netw 2% SIP9
0	P 5201	not used	1p		Pin, 1reihiig, gerade	0	RZ 501	57.88.4222	2k2		8*R Resistor-Netw 2% SIP9
0	P 5202	not used	1p		Pin, 1reihiig, gerade	0	TP 202	54.02.0320	1p		PCB-Flachst 2.8*0.8, gerade
0	P 5203	not used	1p		Pin, 1reihiig, gerade	0	TP 203	54.02.0320	1p		PCB-Flachst 2.8*0.8, gerade
0	P 5204	not used	1p		Pin, 1reihiig, gerade	0	W 1	1.010.115.64			WIRE WRAP DRAHT D .255 L=150
0	P 5205	not used	1p		Pin, 1reihiig, gerade	0	XIC 101	53.03.0182	24p		DIL 0.3", lötl, gerade
0	P 5206	not used	1p		Pin, 1reihiig, gerade	0	XIC 104	53.03.2232	32p		PLCC-Socket
0	P 5207	not used	1p		Pin, 1reihiig, gerade	0	XIC 105	53.03.2232	32p		PLCC-Socket
0	P 5208	not used	1p		Pin, 1reihiig, gerade	0	XIC 106	54.10.3772	72p		SIMM-Socket 72p
0	P 5209	not used	1p		Pin, 1reihiig, gerade	0	XIC 107	53.03.0168	16p		DIL 0.3", lötl, gerade
0	P 5210	not used	1p		Pin, 1reihiig, gerade	0	XIC 204	53.03.0168	16p		DIL 0.3", lötl, gerade
0	P 5211	not used	1p		Pin, 1reihiig, gerade	0	XIC 302	53.03.2252	52p		PLCC-Socket
0	P 5212	not used	1p		Pin, 1reihiig, gerade	0	XIC 401	53.03.2244	44p		PLCC-Socket
0	P 5213	not used	1p		Pin, 1reihiig, gerade	0	XIC 402	54.10.3772	72p		SIMM-Socket 72p
0	P 5214	not used	1p		Pin, 1reihiig, gerade	0	XIC 403	53.03.2252	52p		PLCC-Socket
0	P 5215	not used	1p		Pin, 1reihiig, gerade	0	XIC 601	50.20.3013			Kühlkörper, TO 220
0	P 5216	not used	1p		Pin, 1reihiig, gerade	0	XIC 701	50.20.3013			Kühlkörper, TO 220
0	P 5217	not used	1p		Pin, 1reihiig, gerade	0	Y 101	89.01.0552	3.0720MHz		XTAL HC 18 U
0	P 5218	not used	1p		Pin, 1reihiig, gerade	0	Y 301	89.01.1007	20.000MHz		XTAL HC 49/U
0	P 5219	not used	1p		Pin, 1reihiig, gerade						
0	P 5220	not used	1p		Pin, 1reihiig, gerade						
0	P 5221	not used	1p		Pin, 1reihiig, gerade						
0	P 5222	not used	1p		Pin, 1reihiig, gerade						
0	P 5223	not used	1p		Pin, 1reihiig, gerade						
0	P 5224	not used	1p		Pin, 1reihiig, gerade						
0	P 5225	not used	1p		Pin, 1reihiig, gerade						
0	P 5226	not used	1p		Pin, 1reihiig, gerade						
0	P 5227	not used	1p		Pin, 1reihiig, gerade						
0	P 5228	not used	1p		Pin, 1reihiig, gerade						
0	P 5229	not used	1p		Pin, 1reihiig, gerade						
0	P 5230	not used	1p		Pin, 1reihiig, gerade						
0	P 5231	not used	1p		Pin, 1reihiig, gerade						
0	P 5232	not used	1p		Pin, 1reihiig, gerade						
0	P 5233	not used	1p		Pin, 1reihiig, gerade						

End of List

## Comments:

**Block Diagram**  
**Analog Input / Output 1.866.140**

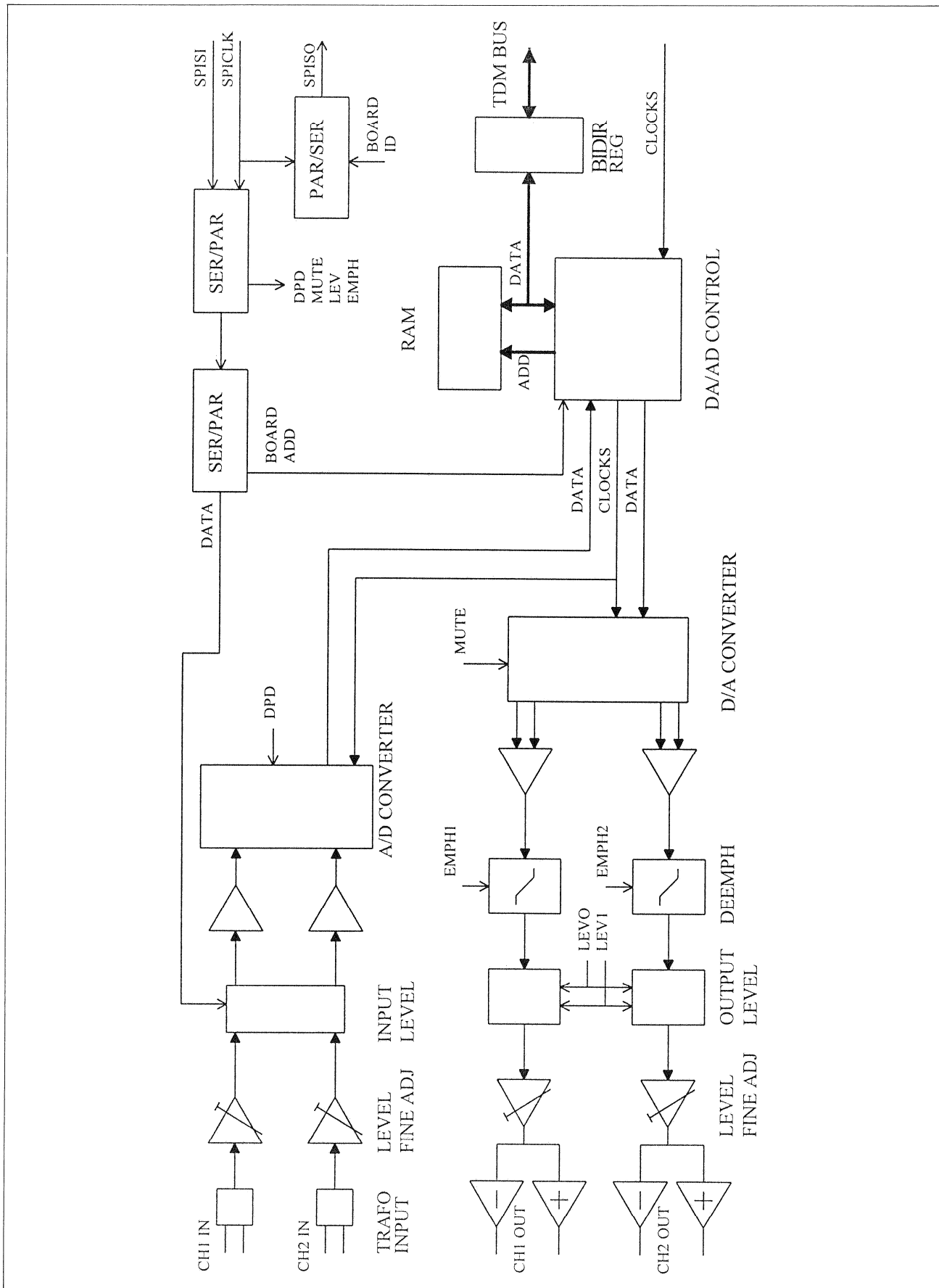

Analog Input / Output 1.866.140.20

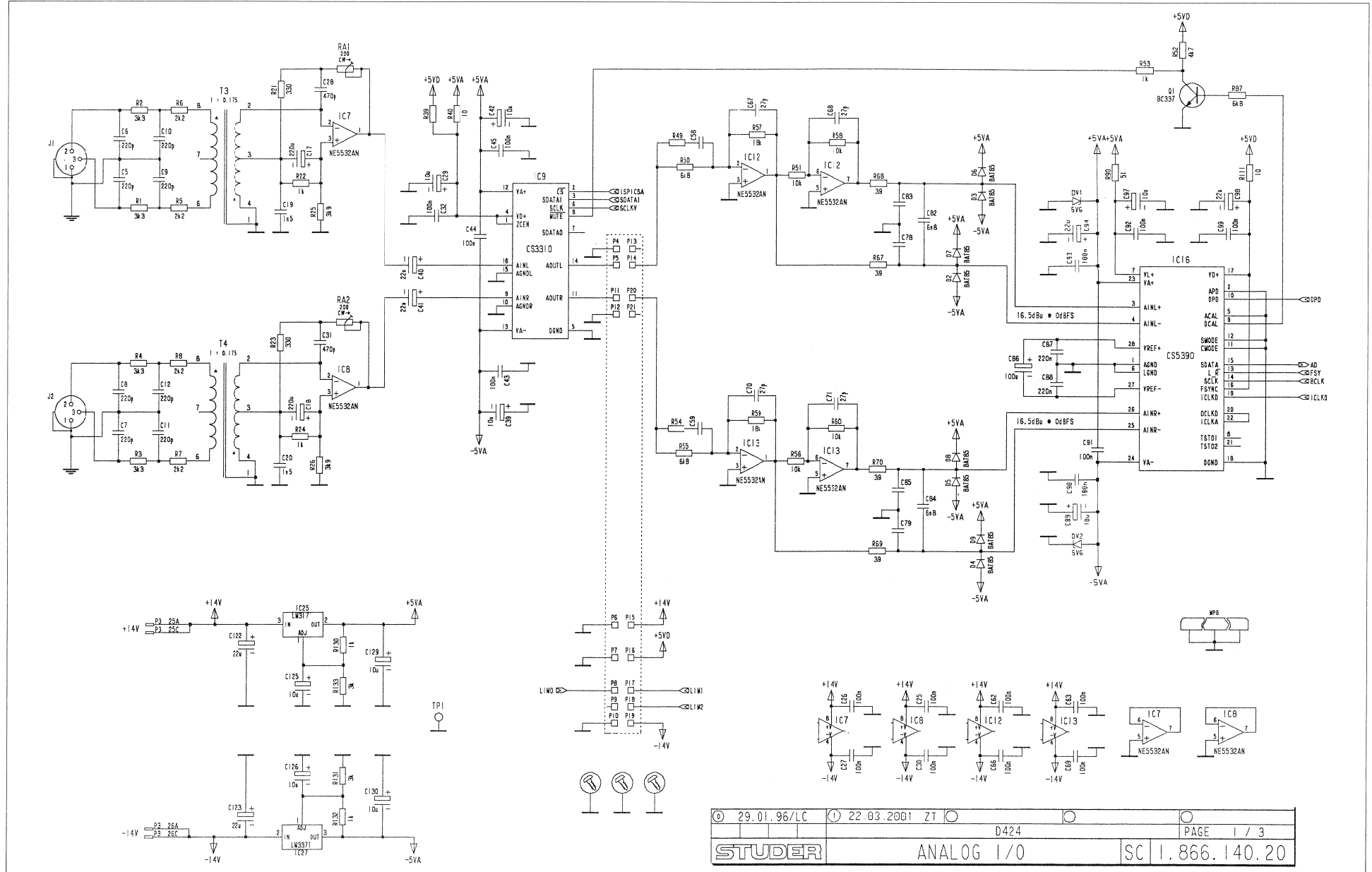





Analog Input / Output I.866.140.20

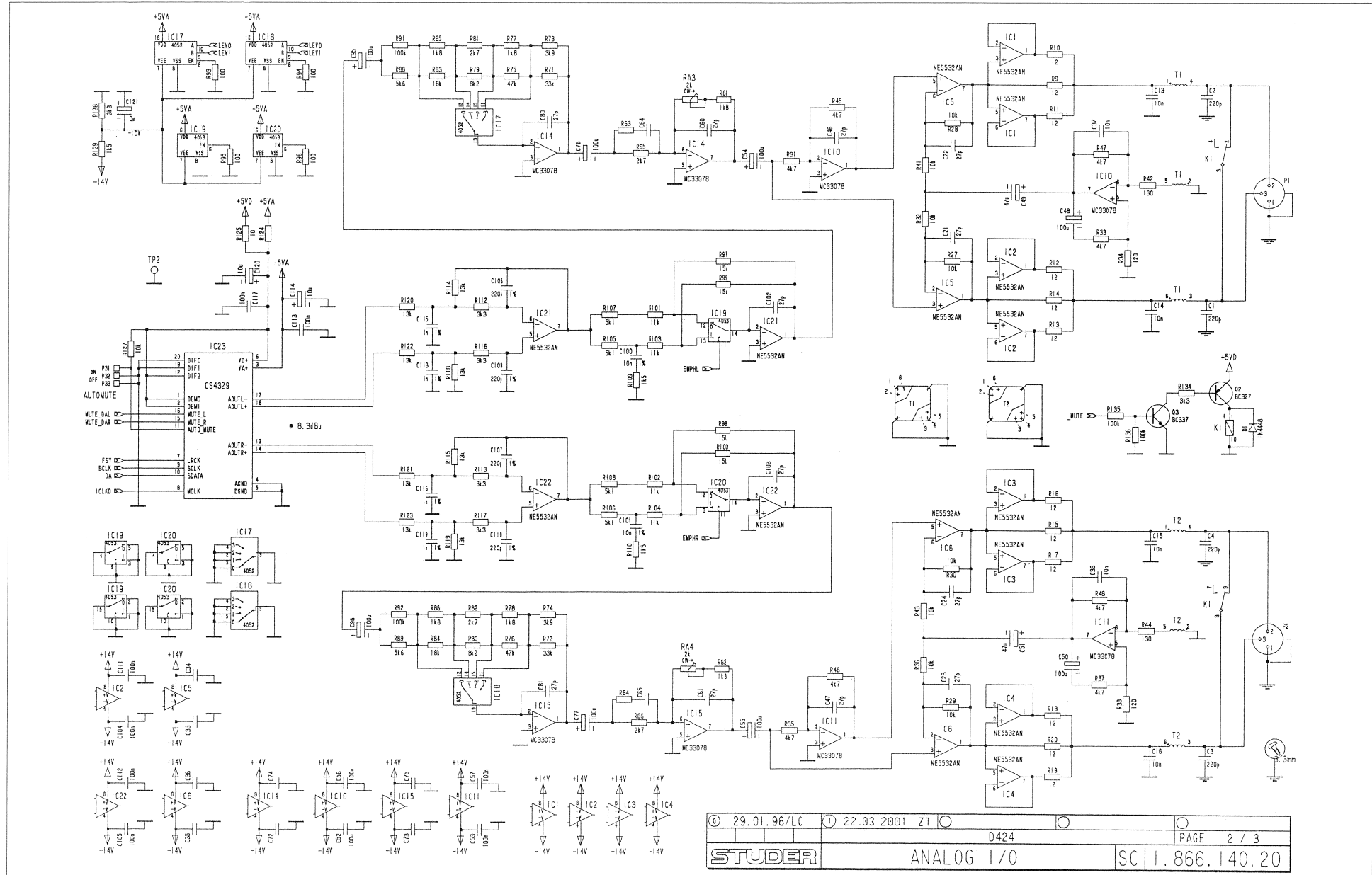

Analog Input / Output 1.866.140.20

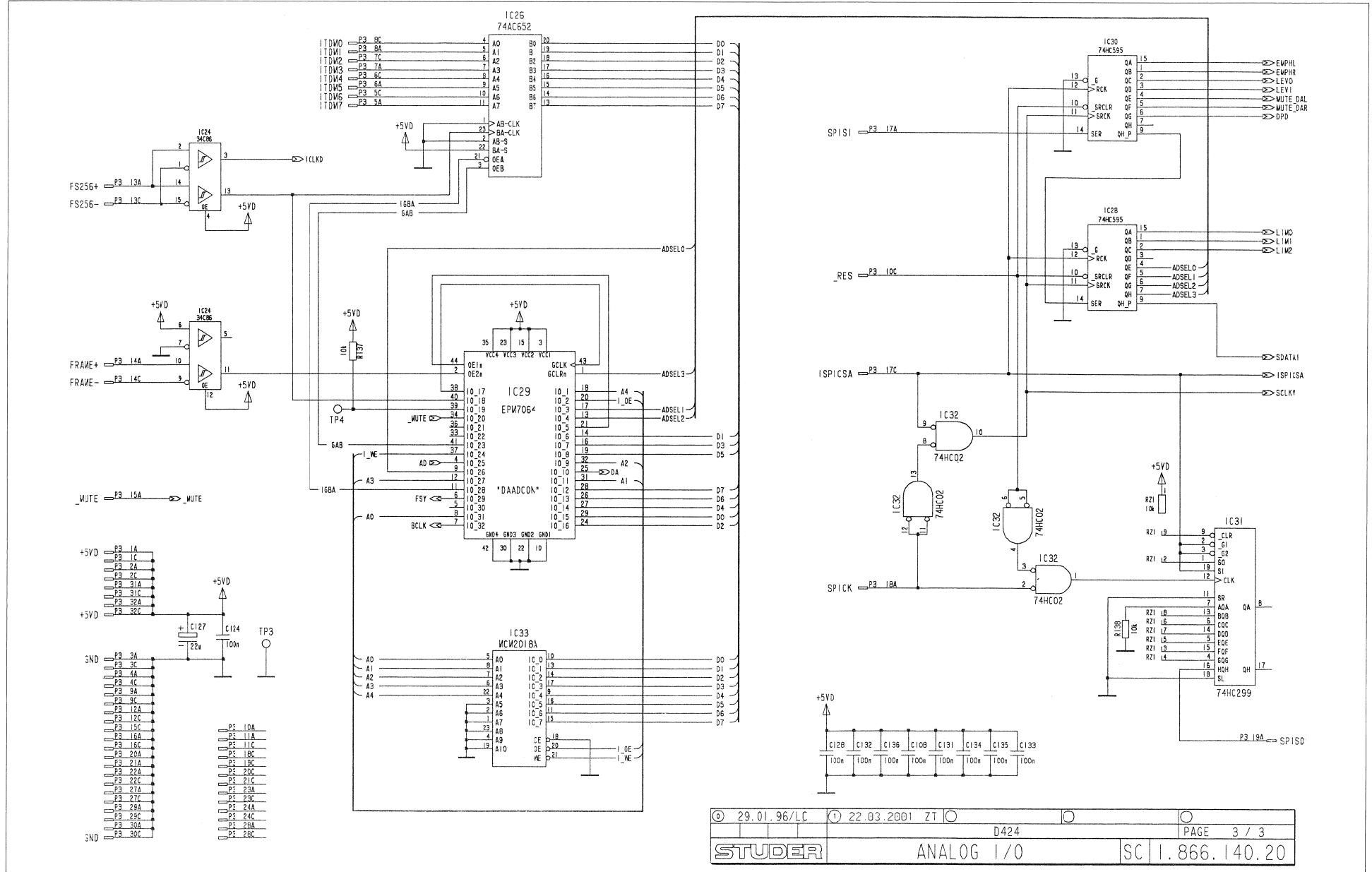



Analog Input / Output 1.866.140.20

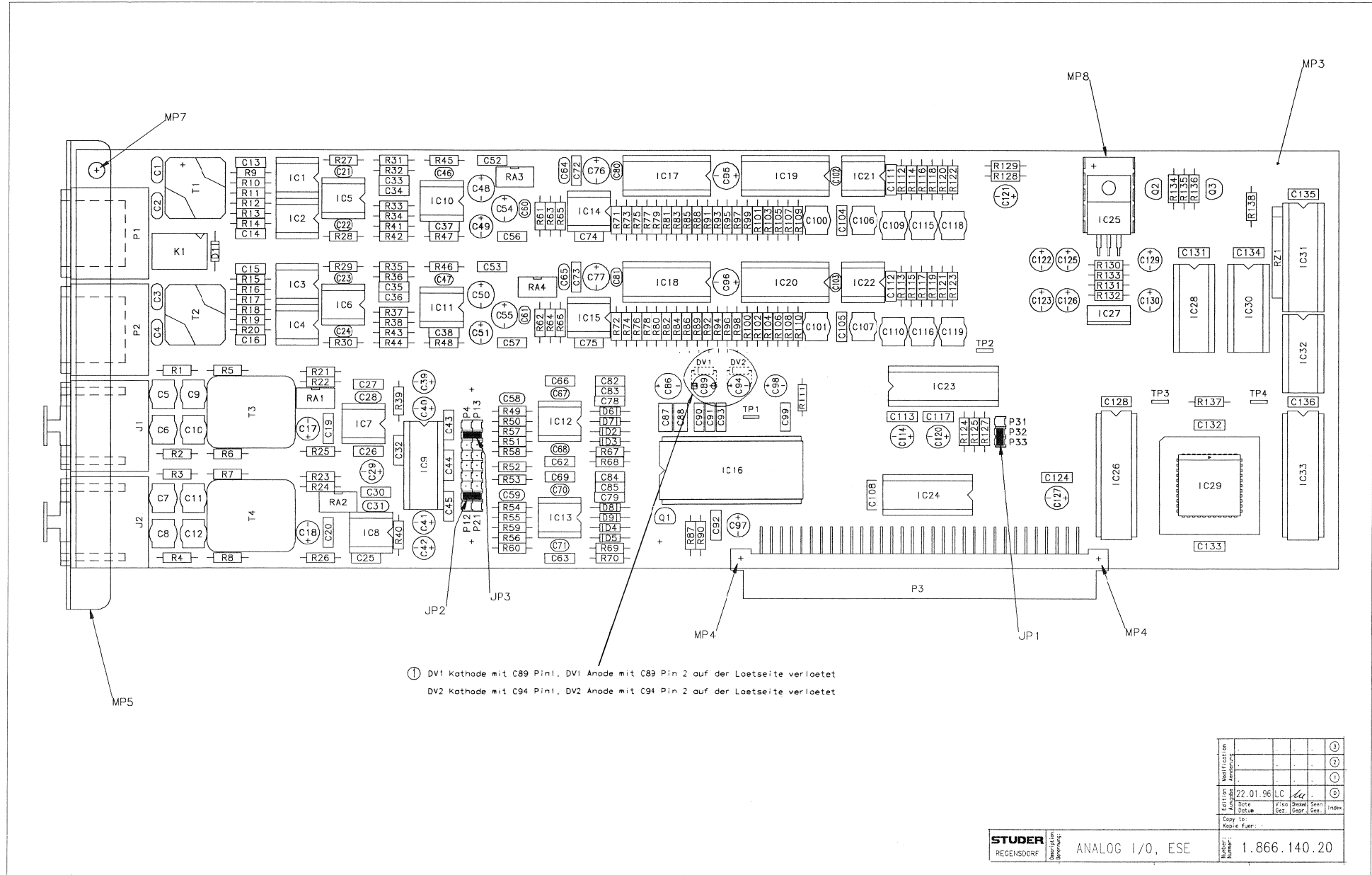

Revision	22.01.96	LC	✓	✓	✓	✓	✓
Gezeichnet	Gez.	Gez.	Gez.	Gez.	Gez.	Gez.	Gez.
Geprüft	Gepr.	Gepr.	Gepr.	Gepr.	Gepr.	Gepr.	Gepr.
Freigegeben	Freigegeben	Freigegeben	Freigegeben	Freigegeben	Freigegeben	Freigegeben	Freigegeben



## Analog Input / Output I.866.140.20

Id	Pos.	Part No.	Qty.	Type/Val.	Description	Id	Pos.	Part No.	Qty.	Type/Val.	Description
0	C 1	59.34.4221		220p	CER 63V, 5%, N750	0	C 84	59.06.0682		6n8	PETP, 63V, 10%, RM5
0	C 2	59.34.4221		220p	CER 63V, 5%, N750	0	C 85	not used		3n3	PETP, 63V, 10%, RM5
0	C 3	59.34.4221		220p	CER 63V, 5%, N750	0	C 86	59.22.4002		100u	EL 16V 20% RM5
0	C 4	59.34.4221		220p	CER 63V, 5%, N750	0	C 87	59.06.0224		220n	PETP, 63V, 10%, RM5
0	C 5	59.05.1221		220p	PP, 1%, 630V	0	C 88	59.06.0224		220n	PETP, 63V, 10%, RM5
0	C 6	59.05.1221		220p	PP, 1%, 630V	0	C 89	59.22.6100		10u	EL 35V 20% RM5
0	C 7	59.05.1221		220p	PP, 1%, 630V	0	C 90	59.06.0104		100n	PETP, 63V, 10%, RM5
0	C 8	59.05.1221		220p	PP, 1%, 630V	0	C 91	59.06.0104		100n	PETP, 63V, 10%, RM5
0	C 9	59.05.1221		220p	PP, 1%, 630V	0	C 92	59.06.0104		100n	PETP, 63V, 10%, RM5
0	C 10	59.05.1221		220p	PP, 1%, 630V	0	C 93	59.06.0104		100n	PETP, 63V, 10%, RM5
0	C 11	59.05.1221		220p	PP, 1%, 630V	0	C 94	59.22.5220		22u	EL 25V 20% RM5
0	C 12	59.05.1221		220p	PP, 1%, 630V	0	C 95	59.22.4002		100u	EL 16V 20% RM5
0	C 13	59.06.0103		10n	PETP, 63V, 10%, RM5	0	C 96	59.22.4002		100u	EL 16V 20% RM5
0	C 14	59.06.0103		10n	PETP, 63V, 10%, RM5	0	C 97	59.22.6100		10u	EL 35V 20% RM5
0	C 15	59.06.0103		10n	PETP, 63V, 10%, RM5	0	C 98	59.22.5220		22u	EL 25V 20% RM5
0	C 16	59.06.0103		10n	PETP, 63V, 10%, RM5	0	C 99	59.06.0104		100n	PETP, 63V, 10%, RM5
0	C 17	59.22.3003		220u	EL 10V 20% RM5	0	C 100	59.05.1103		10n	PP, 1%, 63V
0	C 18	59.22.3003		220u	EL 10V 20% RM5	0	C 101	59.05.1103		10n	PP, 1%, 63V
0	C 19	59.06.0152		1n5	PETP, 63V, 10%, RM5	0	C 102	59.34.2270		27p	CER 63V, 5%, N150
0	C 20	59.06.0152		1n5	PETP, 63V, 10%, RM5	0	C 103	59.34.2270		27p	CER 63V, 5%, N150
0	C 21	59.34.2270		27p	CER 63V, 5%, N150	0	C 104	59.06.0104		100n	PETP, 63V, 10%, RM5
0	C 22	59.34.2270		27p	CER 63V, 5%, N150	0	C 105	59.06.0104		100n	PETP, 63V, 10%, RM5
0	C 23	59.34.2270		27p	CER 63V, 5%, N150	0	C 106	59.05.1221		220p	PP, 1%, 630V
0	C 24	59.34.2270		27p	CER 63V, 5%, N150	0	C 107	59.05.1221		220p	PP, 1%, 630V
0	C 25	59.06.0104		100n	PETP, 63V, 10%, RM5	0	C 108	59.06.0104		100n	PETP, 63V, 10%, RM5
0	C 26	59.06.0104		100n	PETP, 63V, 10%, RM5	0	C 109	59.05.1221		220p	PP, 1%, 630V
0	C 27	59.06.0104		100n	PETP, 63V, 10%, RM5	0	C 110	59.05.1221		220p	PP, 1%, 630V
0	C 28	59.34.5471		470p	CER 63V, 5%, N1500	0	C 111	59.06.0104		100n	PETP, 63V, 10%, RM5
0	C 29	59.22.6100		10u	EL 35V 20% RM5	0	C 112	59.06.0104		100n	PETP, 63V, 10%, RM5
0	C 30	59.06.0104		100n	PETP, 63V, 10%, RM5	0	C 113	59.06.0104		100n	PETP, 63V, 10%, RM5
0	C 31	59.34.5471		470p	CER 63V, 5%, N1500	0	C 114	59.22.6100		10u	EL 35V 20% RM5
0	C 32	59.06.0104		100n	PETP, 63V, 10%, RM5	0	C 115	59.05.1102		1n0	PP, 1%, 630V
0	C 33	not used		100n	PETP, 63V, 10%, RM5	0	C 116	59.05.1102		1n0	PP, 1%, 630V
0	C 34	not used		100n	PETP, 63V, 10%, RM5	0	C 117	59.06.0104		100n	PETP, 63V, 10%, RM5
0	C 35	not used		100n	PETP, 63V, 10%, RM5	0	C 118	59.05.1102		1n0	PP, 1%, 630V
0	C 36	not used		100n	PETP, 63V, 10%, RM5	0	C 119	59.05.1102		1n0	PP, 1%, 630V
0	C 37	59.06.0103		10n	PETP, 63V, 10%, RM5	0	C 120	59.22.6100		10u	CL 35V 20% RM5
0	C 38	59.06.0103		10n	PETP, 63V, 10%, RM5	0	C 121	59.22.6100		10u	EL 35V 20% RM5
0	C 39	59.22.6100		10u	EL 35V 20% RM5	0	C 122	59.22.5220		22u	EL 25V 20% RM5
0	C 40	59.22.5220		22u	EL 25V 20% RM5	0	C 123	59.22.5220		22u	EL 25V 20% RM5
0	C 41	59.22.5220		22u	EL 25V 20% RM5	0	C 124	59.06.0104		100n	PETP, 63V, 10%, RM5
0	C 42	59.22.6100		10u	EL 35V 20% RM5	0	C 125	59.22.6100		10u	EL 35V 20% RM5
0	C 43	59.06.0104		100n	PETP, 63V, 10%, RM5	0	C 126	59.22.6100		10u	EL 35V 20% RM5
0	C 44	59.06.0104		100n	PETP, 63V, 10%, RM5	0	C 127	59.22.5220		22u	EL 25V 20% RM5
0	C 45	59.06.0104		100n	PETP, 63V, 10%, RM5	0	C 128	59.06.0104		100n	PETP, 63V, 10%, RM5
0	C 46	59.34.2270		27p	CER 63V, 5%, N150	0	C 129	59.22.6100		10u	EL 35V 20% RM5
0	C 47	59.34.2270		27p	CER 63V, 5%, N150	0	C 130	59.22.6100		10u	EL 35V 20% RM5
0	C 48	59.22.4002		100u	EL 16V 20% RM5	0	C 131	59.06.0104		100n	PETP, 63V, 10%, RM5
0	C 49	59.22.3470		47u	EL 10V 20% RM5	0	C 132	59.06.0104		100n	PETP, 63V, 10%, RM5
0	C 50	59.22.4002		100u	EL 16V 20% RM5	0	C 133	59.06.0104		100n	PETP, 63V, 10%, RM5
0	C 51	59.22.3470		47u	EL 10V 20% RM5	0	C 134	59.06.0104		100n	PETP, 63V, 10%, RM5
0	C 52	59.06.0104		100n	PETP, 63V, 10%, RM5	0	C 135	59.06.0104		100n	PETP, 63V, 10%, RM5
0	C 53	59.06.0104		100n	PETP, 63V, 10%, RM5	0	C 136	59.06.0104		100n	PETP, 63V, 10%, RM5
0	C 54	59.22.4002		100u	EL 16V 20% RM5	0	D 1	50.04.0125		1N4448	75V, 150mA, 4ns, DO-35
0	C 55	59.22.4002		100u	EL 16V 20% RM5	0	D 2	50.04.0127		BAT85	200mA, Schottky
0	C 56	59.06.0104		100n	PETP, 63V, 10%, RM5	0	D 3	50.04.0127		BAT85	200mA, Schottky
0	C 57	59.06.0104		100n	PETP, 63V, 10%, RM5	0	D 4	50.04.0127		BAT85	200mA, Schottky
0	C 58	not used		470p	CER 63V, 5%, N1500	0	D 5	50.04.0127		BAT85	200mA, Schottky
0	C 59	not used		470p	CER 63V, 5%, N1500	0	D 6	50.04.0127		BAT85	200mA, Schottky
0	C 60	59.34.2270		27p	CER 63V, 5%, N150	0	D 7	50.04.0127		BAT85	200mA, Schottky
0	C 61	59.34.2270		27p	CER 63V, 5%, N150	0	D 8	50.04.0127		BAT85	200mA, Schottky
0	C 62	59.06.0104		100n	PETP, 63V, 10%, RM5	0	D 9	50.04.0127		BAT85	200mA, Schottky
0	C 63	59.06.0104		100n	PETP, 63V, 10%, RM5	2	DV 1	50.04.1108		5V6	Zener, 5%, 0.5W, DO-35
0	C 64	not used		470p	CER 63V, 5%, N1500	2	DV 2	50.04.1108		5V6	Zener, 5%, 0.5W, DO-35
0	C 65	not used		470p	CER 63V, 5%, N1500	0	IC 1	50.09.0106		5532AN	Dual Op-Amp, low noise
0	C 66	59.06.0104		100n	PETP, 63V, 10%, RM5	0	IC 2	50.09.0106		5532AN	Dual Op-Amp, low noise
0	C 67	59.34.2270		27p	CER 63V, 5%, N150	0	IC 3	50.09.0106		5532AN	Dual Op-Amp, low noise
0	C 68	59.34.2270		27p	CER 63V, 5%, N150	0	IC 4	50.09.0106		5532AN	Dual Op-Amp, low noise
0	C 69	59.06.0104		100n	PETP, 63V, 10%, RM5	0	IC 5	50.09.0106		5532AN	Dual Op-Amp, low noise
0	C 70	59.34.2270		27p	CER 63V, 5%, N150	0	IC 6	50.09.0106		5532AN	Dual Op-Amp, low noise
0	C 71	59.34.2270		27p	CER 63V, 5%, N150	0	IC 7	50.09.0106		5532AN	Dual Op-Amp, low noise
0	C 72	not used		100n	PETP, 63V, 10%, RM5	0	IC 8	50.09.0106		5532AN	Dual Op-Amp, low noise
0	C 73	not used		100n	PETP, 63V, 10%, RM5	0	IC 9	50.19.0401		CS3310	2*Volume control digital
0	C 74	not used		100n	PETP, 63V, 10%, RM5	0	IC 10	50.09.0117		MC33078	IC MC 33078 P
0	C 75	not used		100n	PETP, 63V, 10%, RM5	0	IC 11	50.09.0117		MC33078	IC MC 33078 P
0	C 76	59.22.4002		100u	EL 16V 20% RM5	0	IC 12	50.09.0106		5532AN	Dual Op-Amp, low noise
0	C 77	59.22.4002		100u	EL 16V 20% RM5	0	IC 13	50.09.0106		5532AN	Dual Op-Amp, low noise
0	C 78	not used		3n3	PETP, 63V, 10%, RM5	0	IC 14	50.09.0117		MC33078	IC MC 33078 P
0	C 79	not used		3n3	PETP, 63V, 10%, RM5	0	IC 15	50.09.0117		MC33078	IC MC 33078 P
0	C 80	59.34.2270		27p	CER 63V, 5%, N150	0	IC 16	50.19.0205		CS5390	A/D Converter 20bit delta sigma
0	C 81	59.34.2270		27p	CER 63V, 5%, N150	0	IC 17	50.07.0024		4052	Dual 4ch analog mux/demux
0	C 82	59.06.0682		6n8	PETP, 63V, 10%, RM5						
0	C 83	not used		3n3	PETP, 63V, 10%, RM5						



Analog Input / Output I.866.140.20

Id	Pos.	Part No.	Qty.	Type/Val.	Description	Id	Pos.	Part No.	Qty.	Type/Val.	Description
0	IC 18	50.07.0024		4052	Dual 4ch analog mux/demux	0	R 22	57.11.3102	1k0	MF, 1%, 0207	
0	IC 19	50.07.0015		4053	Tripple 2ch analog mux/demux	0	R 23	57.11.3331	330R	MF, 1%, 0207	
0	IC 20	50.07.0015		4053	Tripple 2ch analog mux/demux	0	R 24	57.11.3102	1k0	MF, 1%, 0207	
0	IC 21	50.09.0106		5532AN	Dual Op-Amp,low noise	0	R 25	57.11.3392	3k9	MF, 1%, 0207	
0	IC 22	50.09.0106		5532AN	Dual Op-Amp,low noise	0	R 26	57.11.3392	3k9	MF, 1%, 0207	
0	IC 23	50.19.0114		CS4320/4300	D/A Converter 20/24bit stereo	0	R 27	57.11.3103	10k	MF, 1%, 0207	
0	IC 24	50.15.0128		34C86	IC DS 34 C 86 TN, MC34C86P ,A	0	R 28	57.11.3103	10k	MF, 1%, 0207	
0	IC 25	50.10.0104		LM317SP	Series regulator 1.5A ...+37V	0	R 29	57.11.3103	10k	MF, 1%, 0207	
0	IC 26	50.17.8652		74ABT652	... 74 ABT 652 .	0	R 30	57.11.3103	10k	MF, 1%, 0207	
0	IC 27	50.10.0105		LM337KC	Series regulator 1.5A ...-37V	0	R 31	57.11.3472	4k7	MF, 1%, 0207	
0	IC 28	50.17.1595		74HC595	IC ... 74 HC 595 .. ,A	0	R 32	57.11.3103	10k	MF, 1%, 0207	
0	IC 29	1.866.920.20			SW140 DAADCON (50.63.4202)	0	R 33	57.11.3472	4k7	MF, 1%, 0207	
0	IC 30	50.17.1595		74HC595	IC ... 74 HC 595 .. ,A	0	R 34	57.11.3121	120R	MF, 1%, 0207	
0	IC 31	50.17.1299		74HC299	IC ... 74 HC 299 .. ,A	0	R 35	57.11.3472	4k7	MF, 1%, 0207	
0	IC 32	50.17.1002		74HC 02	IC ... 74 HC 02 .. ,A	0	R 36	57.11.3103	10k	MF, 1%, 0207	
0	IC 33	50.14.1009		7C128A	SRAM 2K*8 35ns	0	R 37	57.11.3472	4k7	MF, 1%, 0207	
0	J 1	54.21.2205		3p	XLR PCB Winkel lock	0	R 38	57.11.3121	120R	MF, 1%, 0207	
0	J 2	54.21.2205		3p	XLR PCB Winkel lock	0	R 39	not used	10R	MF, 1%, 0207	
0	JP 1	54.01.0021		Jumper	0.63*0.63mm, Au	0	R 40	57.11.3100	10R	MF, 1%, 0207	
0	JP 2	54.01.0021		Jumper	0.63*0.63mm, Au	0	R 41	57.11.3103	10k	MF, 1%, 0207	
0	JP 3	54.01.0021		Jumper	0.63*0.63mm, Au	0	R 42	57.11.3131	130R	MF, 1%, 0207	
0	K 1	56.04.0198		2*u	5V 125V 2A Ag/Au	0	R 43	57.11.3103	10k	MF, 1%, 0207	
0	MP 1	1.866.140.10			NR. LABEL	0	R 44	57.11.3131	130R	MF, 1%, 0207	
0	MP 2	43.01.0108		Label	ESE-WARNschild	0	R 45	57.11.3472	4k7	MF, 1%, 0207	
0	MP 3	1.866.140.11			ANALOG I/O PCB	0	R 46	57.11.3472	4k7	MF, 1%, 0207	
0	MP 4	28.99.0119	2 pcs		ROHRNIETE D 2.5*0.15* 9	0	R 47	57.11.3472	4k7	MF, 1%, 0207	
0	MP 5	1.866.140.01			XLR PANELBLECH	0	R 48	not used	100k	MF, 1%, 0207	
1	MP 6	20.24.8754	8 pcs	2.9*6	L -Formschr,K-Torx, Zn bl	0	R 49	57.11.3682	6k8	MF, 1%, 0207	
0	MP 7	21.53.9354		M3*6	Z-Schraube Inbus-Ripp Zn gb ch	0	R 50	57.11.3103	10k	MF, 1%, 0207	
0	MP 8	50.20.3004			Kühlkörper, TO 220, horizontal	0	R 51	57.11.3472	4k7	MF, 1%, 0207	
2	MP 9	43.10.0110		A	Revisions-Etikette 5mm h/blau	0	R 52	57.11.3102	1k0	MF, 1%, 0207	
0	P 1	54.21.2202		3p	XLR PCB Winkel	0	R 53	not used	100k	MF, 1%, 0207	
0	P 2	54.21.2202		3p	XLR PCB Winkel	0	R 54	57.11.3682	6k8	MF, 1%, 0207	
0	P 3	54.01.0365		64p	P EU-C 2 * 32 A,C	0	R 55	57.11.3103	10k	MF, 1%, 0207	
0	P 4	54.01.0020		1p	Pin, 1reihig, gerade	0	R 56	57.11.3183	18k	MF, 1%, 0207	
0	P 5	54.01.0020		1p	Pin, 1reihig, gerade	0	R 57	57.11.3103	10k	MF, 1%, 0207	
0	P 6	54.01.0020		1p	Pin, 1reihig, gerade	0	R 58	57.11.3183	18k	MF, 1%, 0207	
0	P 7	54.01.0020		1p	Pin, 1reihig, gerade	0	R 59	57.11.3103	10k	MF, 1%, 0207	
0	P 8	54.01.0020		1p	Pin, 1reihig, gerade	0	R 60	57.11.3182	1k8	MF, 1%, 0207	
0	P 9	54.01.0020		1p	Pin, 1reihig, gerade	0	R 61	57.11.3182	1k8	MF, 1%, 0207	
0	P 10	54.01.0020		1p	Pin, 1reihig, gerade	0	R 62	not used	100k	MF, 1%, 0207	
0	P 11	54.01.0020		1p	Pin, 1reihig, gerade	0	R 63	not used	100k	MF, 1%, 0207	
0	P 12	54.01.0020		1p	Pin, 1reihig, gerade	0	R 64	57.11.3272	2k7	MF, 1%, 0207	
0	P 13	54.01.0020		1p	Pin, 1reihig, gerade	0	R 65	57.11.3272	2k7	MF, 1%, 0207	
0	P 14	54.01.0020		1p	Pin, 1reihig, gerade	0	R 66	57.11.3390	39R	MF, 1%, 0207	
0	P 15	54.01.0020		1p	Pin, 1reihig, gerade	0	R 67	57.11.3390	39R	MF, 1%, 0207	
0	P 16	54.01.0020		1p	Pin, 1reihig, gerade	0	R 68	57.11.3390	39R	MF, 1%, 0207	
0	P 17	54.01.0020		1p	Pin, 1reihig, gerade	0	R 69	57.11.3333	33k	MF, 1%, 0207	
0	P 18	54.01.0020		1p	Pin, 1reihig, gerade	0	R 70	57.11.3333	33k	MF, 1%, 0207	
0	P 19	54.01.0020		1p	Pin, 1reihig, gerade	0	R 71	57.11.3392	3k9	MF, 1%, 0207	
0	P 20	54.01.0020		1p	Pin, 1reihig, gerade	0	R 72	57.11.3392	3k9	MF, 1%, 0207	
0	P 21	54.01.0020		1p	Pin, 1reihig, gerade	0	R 73	57.11.3473	47k	MF, 1%, 0207	
0	P 31	54.01.0020		1p	Pin, 1reihig, gerade	0	R 74	57.11.3473	47k	MF, 1%, 0207	
0	P 32	54.01.0020		1p	Pin, 1reihig, gerade	0	R 75	57.11.3182	1k8	MF, 1%, 0207	
0	P 33	54.01.0020		1p	Pin, 1reihig, gerade	0	R 76	57.11.3182	1k8	MF, 1%, 0207	
0	Q 1	50.03.0340		BC337-25	800mA, 45V, NPN	0	R 77	57.11.3022	8k2	MF, 1%, 0207	
0	Q 2	50.03.0351		BC327-25	PNP, 800mA	0	R 78	57.11.3822	8k2	MF, 1%, 0207	
0	Q 3	50.03.0340		BC337-25	800mA, 45V, NPN	0	R 79	57.11.3272	2k7	MF, 1%, 0207	
0	R 1	57.11.3332		3k3	MF, 1%, 0207	0	R 80	57.11.3272	2k7	MF, 1%, 0207	
0	R 2	57.11.3332		3k3	MF, 1%, 0207	0	R 81	57.11.3272	2k7	MF, 1%, 0207	
0	R 3	57.11.3332		3k3	MF, 1%, 0207	0	R 82	57.11.3183	18k	MF, 1%, 0207	
0	R 4	57.11.3332		3k3	MF, 1%, 0207	0	R 83	57.11.3183	18k	MF, 1%, 0207	
0	R 5	57.11.3222		2k2	MF, 1%, 0207	0	R 84	57.11.3182	1k8	MF, 1%, 0207	
0	R 6	57.11.3222		2k2	MF, 1%, 0207	0	R 85	57.11.3182	1k8	MF, 1%, 0207	
0	R 7	57.11.3222		2k2	MF, 1%, 0207	0	R 86	57.11.3182	1k8	MF, 1%, 0207	
0	R 8	57.11.3222		2k2	MF, 1%, 0207	0	R 87	57.11.3682	6k8	MF, 1%, 0207	
0	R 9	57.11.3120		12R	MF, 1%, 0207	0	R 88	57.11.3562	5k6	MF, 1%, 0207	
0	R 10	57.11.3120		12R	MF, 1%, 0207	0	R 89	57.11.3562	5k6	MF, 1%, 0207	
0	R 11	57.11.3120		12R	MF, 1%, 0207	0	R 90	57.11.3510	51R	MF, 1%, 0207	
0	R 12	57.11.3120		12R	MF, 1%, 0207	0	R 91	not used	100k	MF, 1%, 0207	
0	R 13	57.11.3120		12R	MF, 1%, 0207	0	R 92	not used	100k	MF, 1%, 0207	
0	R 14	57.11.3120		12R	MF, 1%, 0207	0	R 93	57.11.3101	100R	MF, 1%, 0207	
0	R 15	57.11.3120		12R	MF, 1%, 0207	0	R 94	57.11.3101	100R	MF, 1%, 0207	
0	R 16	57.11.3120		12R	MF, 1%, 0207	0	R 95	57.11.3101	100R	MF, 1%, 0207	
0	R 17	57.11.3120		12R	MF, 1%, 0207	0	R 96	57.11.3101	100R	MF, 1%, 0207	
0	R 18	57.11.3120		12R	MF, 1%, 0207	0	R 97	57.11.3153	15k	MF, 1%, 0207	
0	R 19	57.11.3120		12R	MF, 1%, 0207	0	R 98	57.11.3153	15k	MF, 1%, 0207	
0	R 20	57.11.3120		12R	MF, 1%, 0207	0	R 99	57.11.3153	15k	MF, 1%, 0207	
0	R 21	57.11.3331		330R	MF, 1%, 0207	0	R 100	57.11.3153	15k	MF, 1%, 0207	
						0	R 101	57.11.3113	11k	MF, 1%, 0207	



## Analog Input / Output I.866.140.20

Id	Pos.	Part No.	Qty.	Type/Val.	Description
0	R 102	57.11.3113		11k	MF, 1%, 0207
0	R 103	57.11.3113		11k	MF, 1%, 0207
0	R 104	57.11.3113		11k	MF, 1%, 0207
0	R 105	57.11.3512		5k1	MF, 1%, 0207
0	R 106	57.11.3512		5k1	MF, 1%, 0207
0	R 107	57.11.3512		5k1	MF, 1%, 0207
0	R 108	57.11.3512		5k1	MF, 1%, 0207
0	R 109	57.11.3152		1k5	MF, 1%, 0207
0	R 110	57.11.3152		1k5	MF, 1%, 0207
0	R 111	57.11.3100		10R	MF, 1%, 0207
0	R 112	57.11.3332		3k3	MF, 1%, 0207
0	R 113	57.11.3332		3k3	MF, 1%, 0207
0	R 114	57.11.3133		13k	MF, 1%, 0207
0	R 115	57.11.3133		13k	MF, 1%, 0207
0	R 116	57.11.3332		3k3	MF, 1%, 0207
0	R 117	57.11.3332		3k3	MF, 1%, 0207
0	R 118	57.11.3133		13k	MF, 1%, 0207
0	R 119	57.11.3133		13k	MF, 1%, 0207
0	R 120	57.11.3133		13k	MF, 1%, 0207
0	R 121	57.11.3133		13k	MF, 1%, 0207
0	R 122	57.11.3133		13k	MF, 1%, 0207
0	R 123	57.11.3133		13k	MF, 1%, 0207
0	R 124	not used		10R	MF, 1%, 0207
0	R 125	57.11.3100		10R	MF, 1%, 0207
0	R 127	57.11.3103		10k	MF, 1%, 0207
0	R 128	57.11.3332		3k3	MF, 1%, 0207
0	R 129	57.11.3152		1k5	MF, 1%, 0207
0	R 130	57.11.3102		1k0	MF, 1%, 0207
0	R 131	57.11.3302		3k0	MF, 1%, 0207
0	R 132	57.11.3102		1k0	MF, 1%, 0207
0	R 133	57.11.3302		3k0	MF, 1%, 0207
0	R 134	57.11.3332		3k3	MF, 1%, 0207
0	R 135	57.11.3104		100k	MF, 1%, 0207
0	R 136	57.11.3104		100k	MF, 1%, 0207
0	R 137	57.11.3103		10k	MF, 1%, 0207
0	R 138	57.11.3103		10k	MF, 1%, 0207
0	RA 1	58.01.9201		200R	Cermet, 10%, 0.5W, vertical
0	RA 2	58.01.9201		200R	Cermet, 10%, 0.5W, vertical
0	RA 3	58.01.9202		2k0	Cermet, 10%, 0.5W, vertical
0	RA 4	58.01.9202		2k0	Cermet, 10%, 0.5W, vertical
0	RZ 1	57.88.4103		10k	8*R Resistor-Netw 2% SIP9
0	T 1	1.022.275.00			TRIFILARTRAFO OUTPUT
0	T 2	1.022.275.00			TRIFILARTRAFO OUTPUT
0	T 3	1.022.454.00		1:0.175	EINGANGSTRAFO 1:0,175
0	T 4	1.022.454.00		1:0.175	EINGANGSTRAFO 1:0,175
0	TP 1	54.02.0320		1p	PCB-Flachst 2.8*0.8, gerade
0	TP 2	54.02.0320		1p	PCB-Flachst 2.8*0.8, gerade
0	TP 3	54.02.0320		1p	PCB-Flachst 2.8*0.8, gerade
0	TP 4	54.02.0320		1p	PCB-Flachst 2.8*0.8, gerade
0	XIC 24	53.03.0168		16p	DIL 0.3", löt, gerade
0	XIC 26	53.03.0182		24p	DIL 0.3", löt, gerade
0	XIC 29	53.03.2244		44p	PLCC-Socket

End of List

**Comments:**

(01) modif. MP6

(02) Additional D10,D11,MP9

Block Diagram  
Display Board 1.866.150

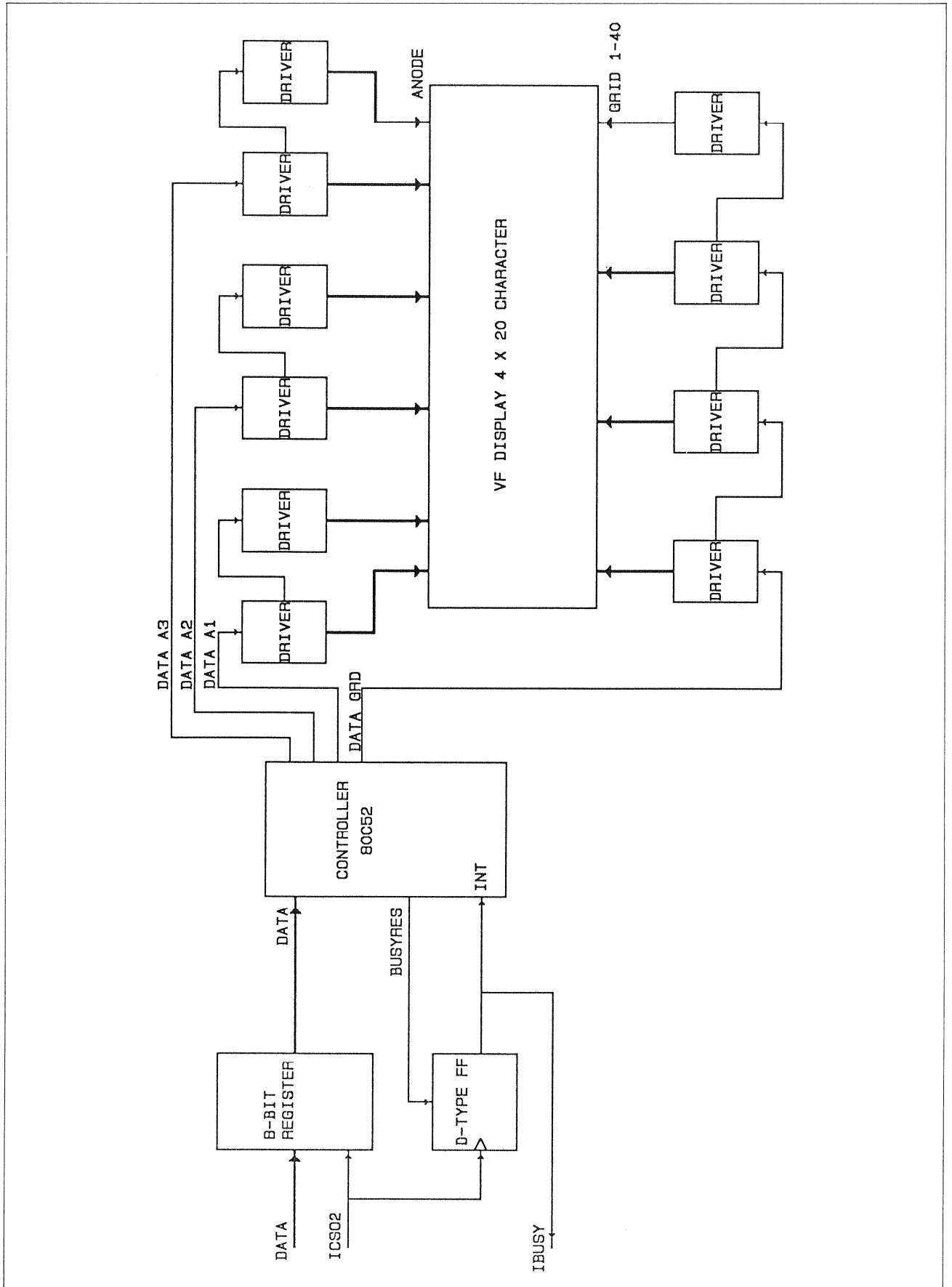

Display Board 1.866.150.00

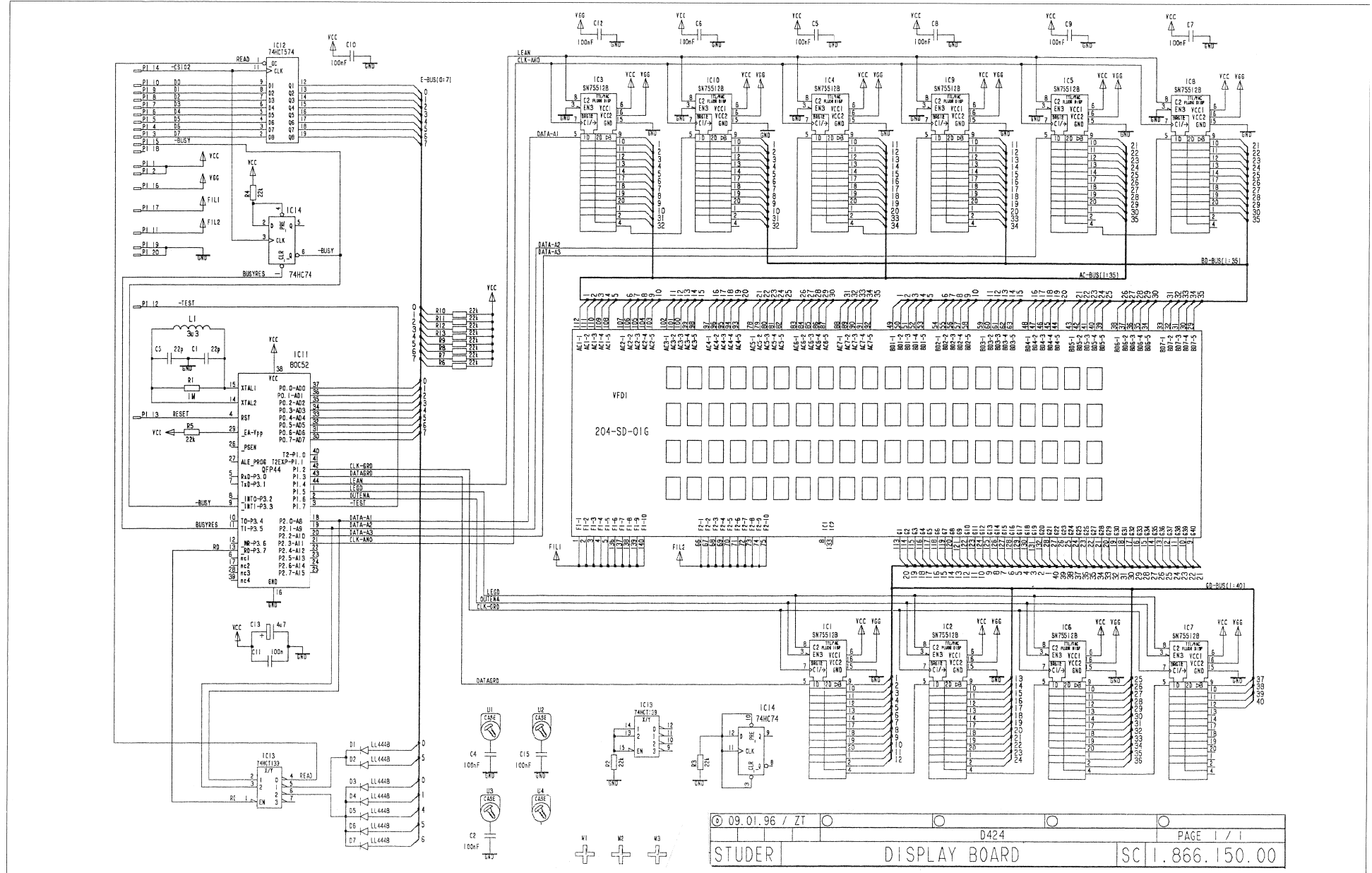





Display Board 1.866.150.00

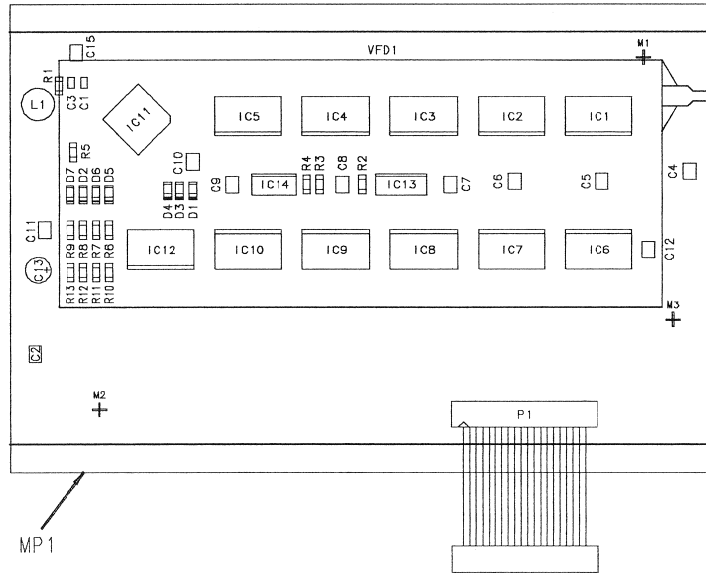

Idx.	Pos.	Part No.	Qty.	Type/Val.	Description
J	C 1	59.60.0220	22p		CER 63V, 5%, CGG, 0805
J	C 2	59.60.1104	100n		CER 63V, 10%, X7R, 1210
J	C 3	59.60.0220	22p		CER 63V, 5%, CGG, 0805
J	C 4	59.60.1104	100n		CER 63V, 10%, X7R, 1210
J	C 5	59.60.1104	100n		CER 63V, 10%, X7R, 1210
J	C 6	59.60.1104	100n		CER 63V, 10%, X7R, 1210
J	C 7	59.60.1104	100n		CER 63V, 10%, X7R, 1210
J	C 8	59.60.1104	100n		CER 63V, 10%, X7R, 1210
J	C 9	59.60.1104	100n		CER 63V, 10%, X7R, 1210
J	C 10	59.60.1104	100n		CER 63V, 10%, X7R, 1210
J	C 11	59.60.1104	100n		CER 63V, 10%, X7R, 1210
J	C 12	59.60.1104	100n		CER 63V, 10%, X7R, 1210
J	C 13	59.30.3479	4u7		TA, 20%, 10V
J	C 15	59.60.1104	100n		CER 63V, 10%, X7R, 1210
J	D 1	50.60.8001	4448		D LL 4448 SOD 80
J	D 2	50.60.8001	4448		D LL 4448 SOD 80
J	D 3	50.60.8001	4448		D LL 4448 SOD 80
J	D 4	50.60.8001	4448		D LL 4448 SOD 80
J	D 5	50.60.8001	4448		D LL 4448 SOD 80
J	D 6	50.60.8001	4448		D LL 4448 SOD 80
J	D 7	50.60.8001	4448		D LL 4448 SOD 80
J	IC 1	50.62.0006		SN75512	IC SN 75 512 BDW
J	IC 2	50.62.0006		SN75512	IC SN 75 512 BDW
J	IC 3	50.62.0006		SN75512	IC SN 75 512 BDW
J	IC 4	50.62.0006		SN75512	IC SN 75 512 BDW
J	IC 5	50.62.0006		SN75512	IC SN 75 512 BDW
J	IC 6	50.62.0006		SN75512	IC SN 75 512 BDW
J	IC 7	50.62.0006		SN75512	IC SN 75 512 BDW
J	IC 8	50.62.0006		SN75512	IC SN 75 512 BDW
J	IC 9	50.62.0006		SN75512	IC SN 75 512 BDW
J	IC 10	50.62.0006		SN75512	IC SN 75 512 BDW
J	IC 11	50.62.0007		80C52	IC 80 C 52 GBB B
J	IC 12	50.62.3574		74HCT574	.. 74 HCT 574 .
J	IC 13	50.62.3139		74HCT139	.. 74 HCT 139 .
J	IC 14	50.62.1074		74HC 74	IC .. 74 HC 74 . A
0	L 1	62.02.3339	3.3uH		L 3.3 U , 20%, RAD., RM 5
0	MP 1	1.866.150.11			DISPLAY BOARD PCB
0	MP 2	1.866.150.10			NR. LABEL
0	MP 3	43.01.0108		Label	ESE-WARNSCHILD
0	P 1	1.023.392.10			FLACHKABEL 20 POL. 0.10M
0	R 1	57.60.1105	1M		MF, 1%, 0204, E24
0	R 2	57.60.1223	22K		MF, 1%, 0204, E24
0	R 3	57.60.1223	22K		MF, 1%, 0204, E24
0	R 4	57.60.1223	22K		MF, 1%, 0204, E24
0	R 5	57.60.1223	22K		MF, 1%, 0204, E24
0	R 6	57.60.1223	22K		MF, 1%, 0204, E24
0	R 7	57.60.1223	22K		MF, 1%, 0204, E24
0	R 8	57.60.1223	22K		MF, 1%, 0204, E24
0	R 9	57.60.1223	22K		MF, 1%, 0204, E24
0	R 10	57.60.1223	22K		MF, 1%, 0204, E24
0	R 11	57.60.1223	22K		MF, 1%, 0204, E24
0	R 12	57.60.1223	22K		MF, 1%, 0204, E24
0	R 13	57.60.1223	22K		MF, 1%, 0204, E24
0	VFD 1	73.01.0204		VFD4*20	Fluoresc. Dot Matrix 4*40 Char

End of List

Comments:

Erstellt	09.01.95	ZT						
Gezeichnet								
Geprüft								
Freigegeben								

STUDER  
REGENSDORF

DISPLAY BOARD "ESE"

Number: 1.866.150.00

Block Diagram  
Keyboard 1.866.160

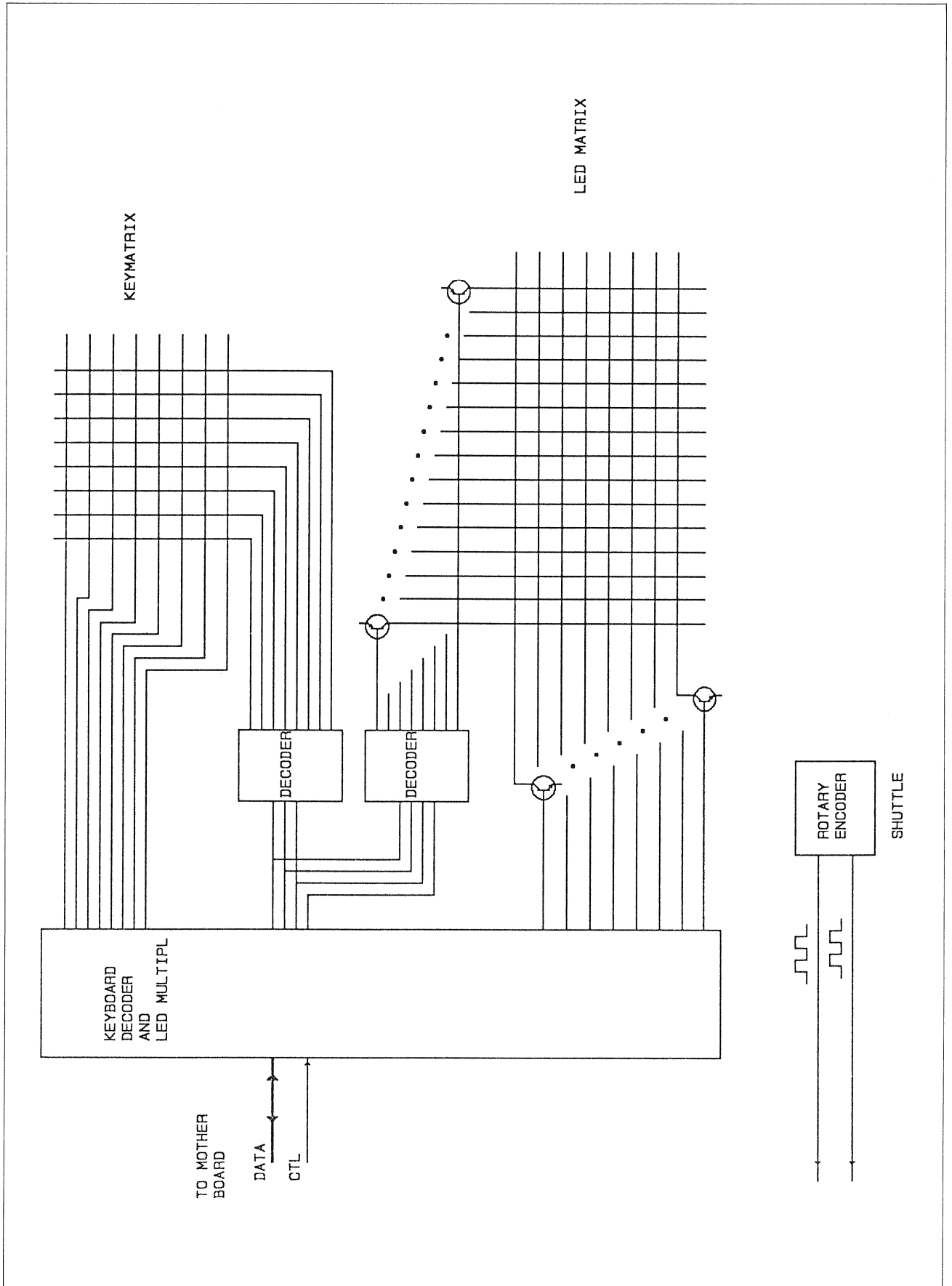



Keyboard 1.866.160.00

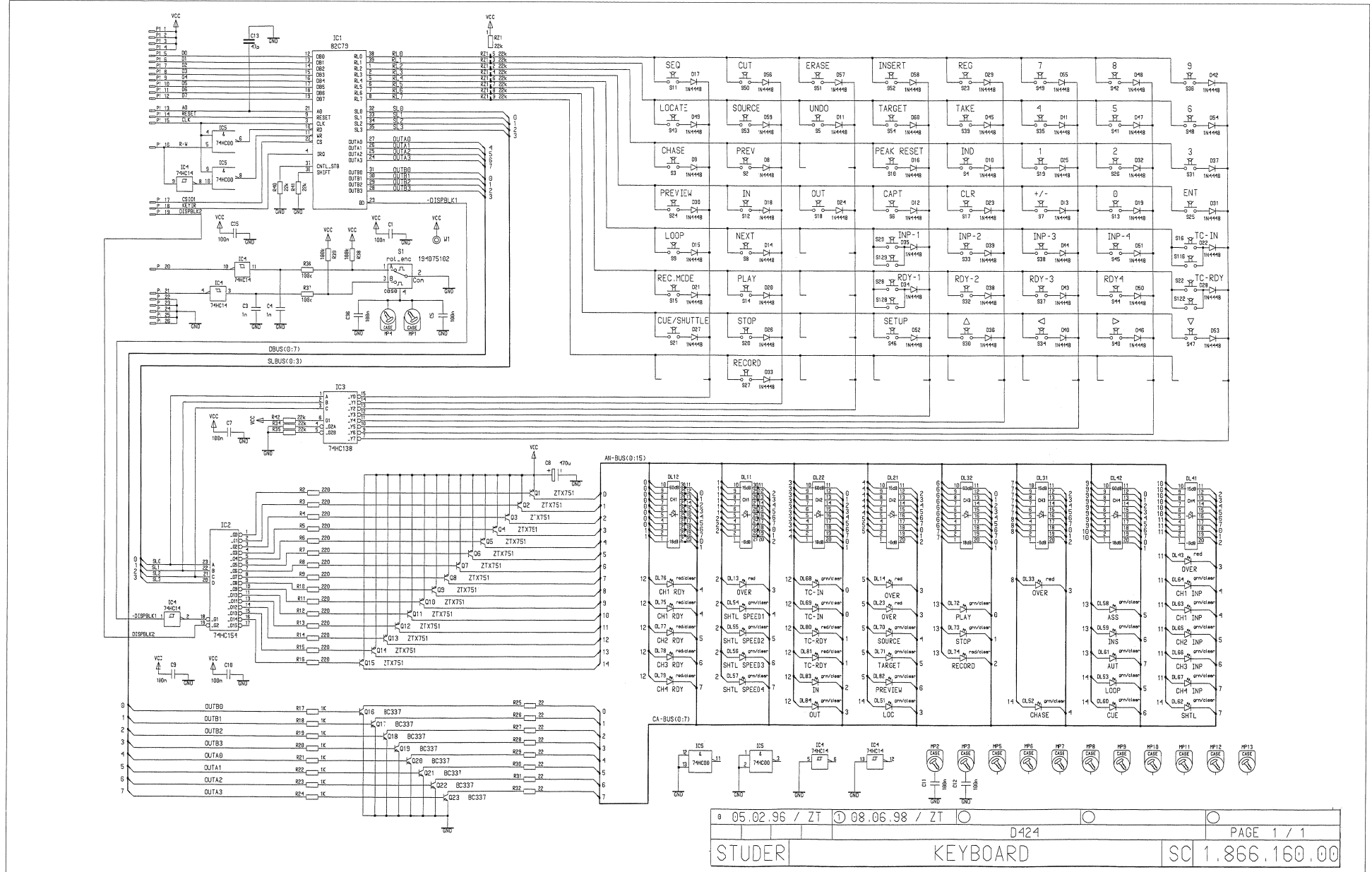



Keyboard 1.866.160.00

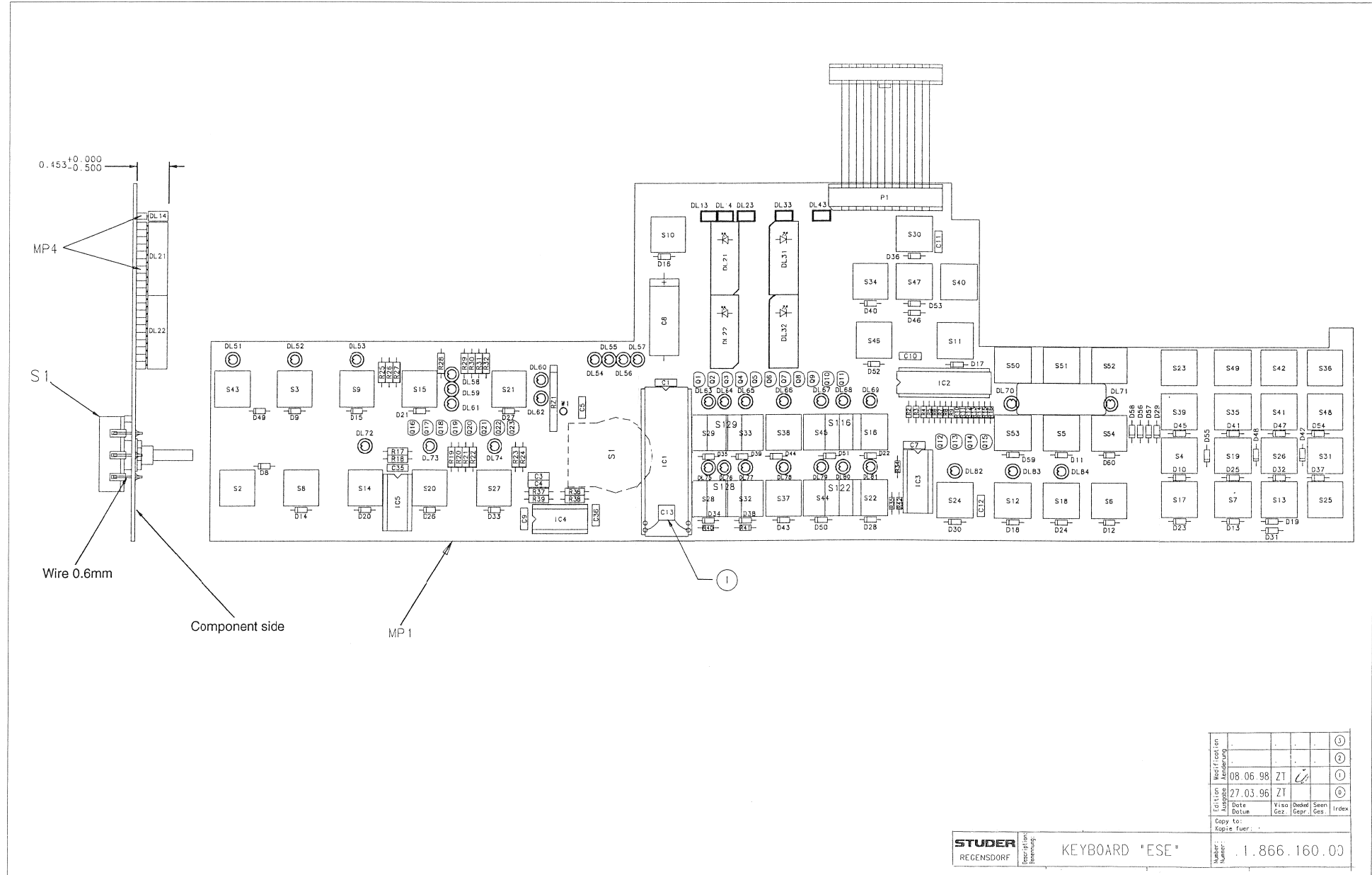

Erstellung					⑤
Modifikation					②
Ausgabe	08.06.98	ZT			①
Datei	27.03.96	ZT			④
Viso					
Gepr.					
Seem.					
Index					

STUDER REGENSDORF  
 KEYBOARD "ESE"  
 Number: 1.866.160.00



Keyboard 1.866.160.00

Idx	Pos.	Part No.	Qty.	Type/Val.	Description	Idx	Pos.	Part No.	Qty.	Type/Val.	Description
0	C 1	59.06.0104	100n		PETP, 63V, 10%, RM5	0	DL 53	50.04.2162		HLMP1540	LED 3mm, grün klar
0	C 3	59.06.0102	1n0		PETP, 63V, 10%, RM5	0	DL 54	50.04.2162		HLMP1540	LED 3mm, grün klar
0	C 4	59.06.0102	1n0		PETP, 63V, 10%, RM5	0	DL 55	50.04.2162		HLMP1540	LED 3mm, grün klar
0	C 5	59.06.0104	100n		PETP, 63V, 10%, RM5	0	DL 56	50.04.2162		HLMP1540	LED 3mm, grün klar
0	C 7	59.06.0104	100n		PETP, 63V, 10%, RM5	0	DL 57	50.04.2162		HLMP1540	LED 3mm, grün klar
0	C 8	59.25.3471	470u		C-EL, 20%, 16V	0	DL 58	50.04.2162		HLMP1540	LED 3mm, grün klar
0	C 9	59.06.0104	100n		PETP, 63V, 10%, RM5	0	DL 59	50.04.2162		HLMP1540	LED 3mm, grün klar
0	C 10	59.06.0104	100n		PETP, 63V, 10%, RM5	0	DL 60	50.04.2162		HLMP1540	LED 3mm, grün klar
0	C 11	59.06.0104	100n		PETP, 63V, 10%, RM5	0	DL 61	50.04.2162		HLMP1540	LED 3mm, grün klar
0	C 12	59.06.0104	100n		PETP, 63V, 10%, RM5	0	DL 62	50.04.2162		HLMP1540	LED 3mm, grün klar
1	C 13	59.34.2470	47p		CER 63V, 5%, N150	0	DL 63	not used		HLMP1540	LED 3mm, grün klar
0	C 35	59.06.0104	100n		PETP, 63V, 10%, RM5	0	DL 64	50.04.2162		HLMP1540	LED 3mm, grün klar
0	C 36	59.06.0104	100n		PETP, 63V, 10%, RM5	0	DL 65	not used		HLMP1540	LED 3mm, grün klar
0	D 8	50.04.0125	1N4448		75V, 150mA, 4ns, DO-35	0	DL 66	50.04.2162		HLMP1540	LED 3mm, grün klar
0	D 9	50.04.0125	1N4448		75V, 150mA, 4ns, DO-35	0	DL 67	not used		HLMP1540	LED 3mm, grün klar
0	D 10	50.04.0125	1N4448		75V, 150mA, 4ns, DO-35	0	DL 68	50.04.2162		HLMP1540	LED 3mm, grün klar
0	D 11	50.04.0125	1N4448		75V, 150mA, 4ns, DO-35	0	DL 69	not used		HLMP1540	LED 3mm, grün klar
0	D 12	50.04.0125	1N4448		75V, 150mA, 4ns, DO-35	0	DL 70	50.04.2162		HLMP1540	LED 3mm, grün klar
0	D 13	50.04.0125	1N4448		75V, 150mA, 4ns, DO-35	0	DL 71	50.04.2162		HLMP1540	LED 3mm, grün klar
0	D 14	50.04.0125	1N4448		75V, 150mA, 4ns, DO-35	0	DL 72	50.04.2162		HLMP1540	LED 3mm, grün klar
0	D 15	50.04.0125	1N4448		75V, 150mA, 4ns, DO-35	0	DL 73	50.04.2162		HLMP1540	LED 3mm, grün klar
0	D 16	50.04.0125	1N4448		75V, 150mA, 4ns, DO-35	0	DL 74	50.04.2159		HLMP1340	LED 3mm, rot klar
0	D 17	50.04.0125	1N4448		75V, 150mA, 4ns, DO-35	0	DL 75	not used		HLMP1340	LED 3mm, rot klar
0	D 18	50.04.0125	1N4448		75V, 150mA, 4ns, DO-35	0	DL 76	50.04.2159		HLMP1340	LED 3mm, rot klar
0	D 19	50.04.0125	1N4448		75V, 150mA, 4ns, DO-35	0	DL 77	not used		HLMP1340	LED 3mm, rot klar
0	D 20	50.04.0125	1N4448		75V, 150mA, 4ns, DO-35	0	DL 78	50.04.2159		HLMP1340	LED 3mm, rot klar
0	D 21	50.04.0125	1N4448		75V, 150mA, 4ns, DO-35	0	DL 79	not used		HLMP1340	LED 3mm, rot klar
0	D 22	50.04.0125	1N4448		75V, 150mA, 4ns, DO-35	0	DL 80	50.04.2159		HLMP1340	LED 3mm, rot klar
0	D 23	50.04.0125	1N4448		75V, 150mA, 4ns, DO-35	0	DL 81	not used		HLMP1340	LED 3mm, rot klar
0	D 24	50.04.0125	1N4448		75V, 150mA, 4ns, DO-35	0	DL 82	50.04.2162		HLMP1540	LED 3mm, grün klar
0	D 25	50.04.0125	1N4448		75V, 150mA, 4ns, DO-35	0	DL 83	50.04.2162		HLMP1540	LED 3mm, grün klar
0	D 26	50.04.0125	1N4448		75V, 150mA, 4ns, DO-35	0	DL 84	50.04.2162		HLMP1540	LED 3mm, grün klar
0	D 27	50.04.0125	1N4448		75V, 150mA, 4ns, DO-35	0	IC 1	50.16.0703		82C79	TMP 82 C 79 P-2 (C-MOS)
0	D 28	50.04.0125	1N4448		75V, 150mA, 4ns, DO-35	0	IC 2	50.17.1154		74HC154	4-to16 Line driver, DIP 24-300
0	D 29	50.04.0125	1N4448		75V, 150mA, 4ns, DO-35	0	IC 3	50.17.1138		74HC138	IC ... 74 HC 138 .. ,A
0	D 30	50.04.0125	1N4448		75V, 150mA, 4ns, DO-35	0	IC 4	50.17.1014		74HC14	IC ... 74 HC 14 .. ,A
0	D 31	50.04.0125	1N4448		75V, 150mA, 4ns, DO-35	0	IC 5	50.17.1000		74HC00	IC ... 74 HC 00 .. ,A
0	D 32	50.04.0125	1N4448		75V, 150mA, 4ns, DO-35	0	MP 1	1.866.160.11			KEYBOARD PCB
0	D 33	50.04.0125	1N4448		75V, 150mA, 4ns, DO-35	0	MP 2	1.866.160.10			NR. LABEL
0	D 34	50.04.0125	1N4448		75V, 150mA, 4ns, DO-35	0	MP 3	43.01.0108		.Label	ESE-WARNSCHILD
0	D 35	50.04.0125	1N4448		75V, 150mA, 4ns, DO-35	0	MP 4	53.03.0218	84 pcs	1p	single-in-line
0	D 37	50.04.0125	1N4448		75V, 150mA, 4ns, DO-35	0	MP 5	1.865.140.03	26 pcs		DIODENABSTANDSHALTER
0	D 38	not used	1N4448		75V, 150mA, 4ns, DO-35						
0	D 39	not used	1N4448		75V, 150mA, 4ns, DO-35	0	P 1	1.023.312.07			FLACHKABEL 26 POL. 0,145M
0	D 40	50.04.0125	1N4448		75V, 150mA, 4ns, DO-35						
0	D 41	50.04.0125	1N4448		75V, 150mA, 4ns, DO-35	0	Q 1	50.03.0352		ZTX751S	ZTX 751 S
0	D 42	50.04.0125	1N4448		75V, 150mA, 4ns, DO-35	0	Q 2	50.03.0352		ZTX751S	ZTX 751 S
0	D 43	50.04.0125	1N4448		75V, 150mA, 4ns, DO-35	0	Q 3	50.03.0352		ZTX751S	ZTX 751 S
0	D 44	50.04.0125	1N4448		75V, 150mA, 4ns, DO-35	0	Q 4	50.03.0352		ZTX751S	ZTX 751 S
0	D 45	50.04.0125	1N4448		75V, 150mA, 4ns, DO-35	0	Q 5	50.03.0352		ZTX751S	ZTX 751 S
0	D 46	50.04.0125	1N4448		75V, 150mA, 4ns, DO-35	0	Q 6	50.03.0352		ZTX751S	ZTX 751 S
0	D 47	50.04.0125	1N4448		75V, 150mA, 4ns, DO-35	0	Q 7	50.03.0352		ZTX751S	ZTX 751 S
0	D 48	50.04.0125	1N4448		75V, 150mA, 4ns, DO-35	0	Q 8	50.03.0352		ZTX751S	ZTX 751 S
0	D 49	50.04.0125	1N4448		75V, 150mA, 4ns, DO-35	0	Q 9	50.03.0352		ZTX751S	ZTX 751 S
0	D 50	not used	1N4448		75V, 150mA, 4ns, DO-35	0	Q 10	50.03.0352		ZTX751S	ZTX 751 S
0	D 51	not used	1N4448		75V, 150mA, 4ns, DO-35	0	Q 11	50.03.0352		ZTX751S	ZTX 751 S
0	D 52	50.04.0125	1N4448		75V, 150mA, 4ns, DO-35	0	Q 12	50.03.0352		ZTX751S	ZTX 751 S
0	D 53	50.04.0125	1N4448		75V, 150mA, 4ns, DO-35	0	Q 13	50.03.0352		ZTX751S	ZTX 751 S
0	D 54	50.04.0125	1N4448		75V, 150mA, 4ns, DO-35	0	Q 14	50.03.0352		ZTX751S	ZTX 751 S
0	D 55	50.04.0125	1N4448		75V, 150mA, 4ns, DO-35	0	Q 15	50.03.0352		ZTX751S	ZTX 751 S
0	D 56	50.04.0125	1N4448		75V, 150mA, 4ns, DO-35	0	Q 16	50.03.0340		BC337-25	800mA, 45V, NPN
0	D 57	50.04.0125	1N4448		75V, 150mA, 4ns, DO-35	0	Q 17	50.03.0340		BC337-25	800mA, 45V, NPN
0	D 58	50.04.0125	1N4448		75V, 150mA, 4ns, DO-35	0	Q 18	50.03.0340		BC337-25	800mA, 45V, NPN
0	D 59	50.04.0125	1N4448		75V, 150mA, 4ns, DO-35	0	Q 19	50.03.0340		BC337-25	800mA, 45V, NPN
0	D 60	50.04.0125	1N4448		75V, 150mA, 4ns, DO-35	0	Q 20	50.03.0340		BC337-25	800mA, 45V, NPN
0	DL 11	not used			DLZ HDSP-4850 10*D GN	0	Q 21	50.03.0340		BC337-25	800mA, 45V, NPN
0	DL 12	not used			DLZ HDSP-4850 10*D GN	0	Q 22	50.03.0340		BC337-25	800mA, 45V, NPN
0	DL 13	not used			DL MV 57124 A, RT	0	Q 23	50.03.0340		BC337-25	800mA, 45V, NPN
0	DL 14	50.04.2119	MV57124A		DL MV 57124 A, RT	0	R 2	57.10.1221		220R	MF, 1%, 0204
0	DL 21	50.04.2811			DLZ HDSP-4850 10*D GN	0	R 3	57.10.1221		220R	MF, 1%, 0204
0	DL 22	50.04.2811			DLZ HDSP-4850 10*D GN	0	R 4	57.10.1221		220R	MF, 1%, 0204
0	DL 23	not used			DL MV 57124 A, RT	0	R 5	57.10.1221		220R	MF, 1%, 0204
0	DL 31	50.04.2811			DLZ HDSP-4850 10*D GN	0	R 6	57.10.1221		220R	MF, 1%, 0204
0	DL 32	50.04.2811			DLZ HDSP-4850 10*D GN	0	R 7	57.10.1221		220R	MF, 1%, 0204
0	DL 33	50.04.2119	MV57124A		DL MV 57124 A, RT	0	R 8	57.10.1221		220R	MF, 1%, 0204
0	DL 41	not used			DLZ HDSP-4850 10*D GN	0	R 9	57.10.1221		220R	MF, 1%, 0204
0	DL 42	not used			DLZ HDSP-4850 10*D GN	0	R 10	57.10.1221		220R	MF, 1%, 0204
0	DL 43	not used			DL MV 57124 A, RT	0	R 11	57.10.1221		220R	MF, 1%, 0204
0	DL 51	50.04.2162	HLMP1540		LED 3mm, grün klar	0	R 12	57.10.1221		220R	MF, 1%, 0204
0	DL 52	50.04.2162	HLMP1540		LED 3mm, grün klar	0	R 13	57.10.1221		220R	MF, 1%, 0204



Keyboard 1.866.160.00

Idx	Pos.	Part No.	Qty.	Type/Val.	Description	Idx	Pos.	Part No.	Qty.	Type/Val.	Description
0	R 14	57.10.1221		220R	MF, 1%, 0204	0	S 39	55.99.0158		1*a	Tastenschalter impulse
0	R 15	57.10.1221		220R	MF, 1%, 0204	0	S 40	55.99.0158		1*a	Tastenschalter impulse
0	R 16	57.10.1221		220R	MF, 1%, 0204	0	S 41	55.99.0158		1*a	Tastenschalter impulse
0	R 17	57.11.3102		1k0	MF, 1%, 0207	0	S 42	55.99.0158		1*a	Tastenschalter impulse
0	R 18	57.11.3102		1k0	MF, 1%, 0207	0	S 43	55.99.0158		1*a	Tastenschalter impulse
0	R 19	57.11.3102		1k0	MF, 1%, 0207	0	S 44	not used		1*a	Tastenschalter impulse
0	R 20	57.11.3102		1k0	MF, 1%, 0207	0	S 45	not used		1*a	Tastenschalter impulse
0	R 21	57.11.3102		1k0	MF, 1%, 0207	0	S 46	55.99.0158		1*a	Tastenschalter impulse
0	R 22	57.11.3102		1k0	MF, 1%, 0207	0	S 47	55.99.0158		1*a	Tastenschalter impulse
0	R 23	57.11.3102		1k0	MF, 1%, 0207	0	S 48	55.99.0158		1*a	Tastenschalter impulse
0	R 24	57.11.3102		1k0	MF, 1%, 0207	0	S 49	55.99.0158		1*a	Tastenschalter impulse
0	R 25	57.11.3220		22R	MF, 1%, 0207	0	S 50	55.99.0158		1*a	Tastenschalter impulse
0	R 26	57.11.3220		22R	MF, 1%, 0207	0	S 51	55.99.0158		1*a	Tastenschalter impulse
0	R 27	57.11.3220		22R	MF, 1%, 0207	0	S 52	55.99.0158		1*a	Tastenschalter impulse
0	R 28	57.11.3220		22R	MF, 1%, 0207	0	S 53	55.99.0158		1*a	Tastenschalter impulse
0	R 29	57.11.3220		22R	MF, 1%, 0207	0	S 54	55.99.0158		1*a	Tastenschalter impulse
0	R 30	57.11.3220		22R	MF, 1%, 0207	0	S 116	55.99.0158		1*a	Tastenschalter impulse
0	R 31	57.11.3220		22R	MF, 1%, 0207	0	S 122	55.99.0158		1*a	Tastenschalter impulse
0	R 32	57.11.3220		22R	MF, 1%, 0207	0	S 128	55.99.0158		1*a	Tastenschalter impulse
0	R 34	57.10.1223		22k	MF, 1%, 0204	0	S 129	55.99.0158		1*a	Tastenschalter impulse
0	R 35	57.10.1223		22k	MF, 1%, 0204						
0	R 36	57.11.3104		100k	MF, 1%, 0207						
0	R 37	57.11.3104		100k	MF, 1%, 0207						
0	R 38	57.11.3104		100k	MF, 1%, 0207						
0	R 39	57.11.3104		100k	MF, 1%, 0207						
0	R 40	57.10.1223		22k	MF, 1%, 0204						
0	R 41	57.10.1223		22k	MF, 1%, 0204						
0	R 42	57.10.1223		22k	MF, 1%, 0204						
0	RZ 1	57.88.4223		22k	8*R Resistor-Netw 2% SIP9						
0	S 1	1.940.751.02			ROTARY ENCODER						
0	S 2	55.99.0158		1*a	Tastenschalter impulse						
0	S 3	55.99.0158		1*a	Tastenschalter impulse						
0	S 4	55.99.0158		1*a	Tastenschalter impulse						
0	S 5	55.99.0158		1*a	Tastenschalter impulse						
0	S 6	55.99.0158		1*a	Tastenschalter impulse						
0	S 7	55.99.0158		1*a	Tastenschalter impulse						
0	S 8	55.99.0158		1*a	Tastenschalter impulse						
0	S 9	55.99.0158		1*a	Tastenschalter impulse						
0	S 10	55.99.0158		1*a	Tastenschalter impulse						
0	S 11	55.99.0158		1*a	Tastenschalter impulse						
0	S 12	55.99.0158		1*a	Tastenschalter impulse						
0	S 13	55.99.0158		1*a	Tastenschalter impulse						
0	S 14	55.99.0158		1*a	Tastenschalter impulse						
0	S 15	55.99.0158		1*a	Tastenschalter impulse						
0	S 16	not used		1*a	Tastenschalter impulse						
0	S 17	55.99.0158		1*a	Tastenschalter impulse						
0	S 18	55.99.0158		1*a	Tastenschalter impulse						
0	S 19	55.99.0158		1*a	Tastenschalter impulse						
0	S 20	55.99.0158		1*a	Tastenschalter impulse						
0	S 21	55.99.0158		1*a	Tastenschalter impulse						
0	S 22	not used		1*a	Tastenschalter impulse						
0	S 23	55.99.0158		1*a	Tastenschalter impulse						
0	S 24	55.99.0158		1*a	Tastenschalter impulse						
0	S 25	55.99.0158		1*a	Tastenschalter impulse						
0	S 26	55.99.0158		1*a	Tastenschalter impulse						
0	S 27	55.99.0158		1*a	Tastenschalter impulse						
0	S 28	not used		1*a	Tastenschalter impulse						
0	S 29	not used		1*a	Tastenschalter impulse						
0	S 30	55.99.0158		1*a	Tastenschalter impulse						
0	S 31	55.99.0158		1*a	Tastenschalter impulse						
0	S 32	not used		1*a	Tastenschalter impulse						
0	S 33	not used		1*a	Tastenschalter impulse						
0	S 34	55.99.0158		1*a	Tastenschalter impulse						
0	S 35	55.99.0158		1*a	Tastenschalter impulse						
0	S 36	55.99.0158		1*a	Tastenschalter impulse						
0	S 37	55.99.0158		1*a	Tastenschalter impulse						
0	S 38	55.99.0158		1*a	Tastenschalter impulse						

End of List

Comments  
C13 additional

Clock Input / Output 1.866.170.00

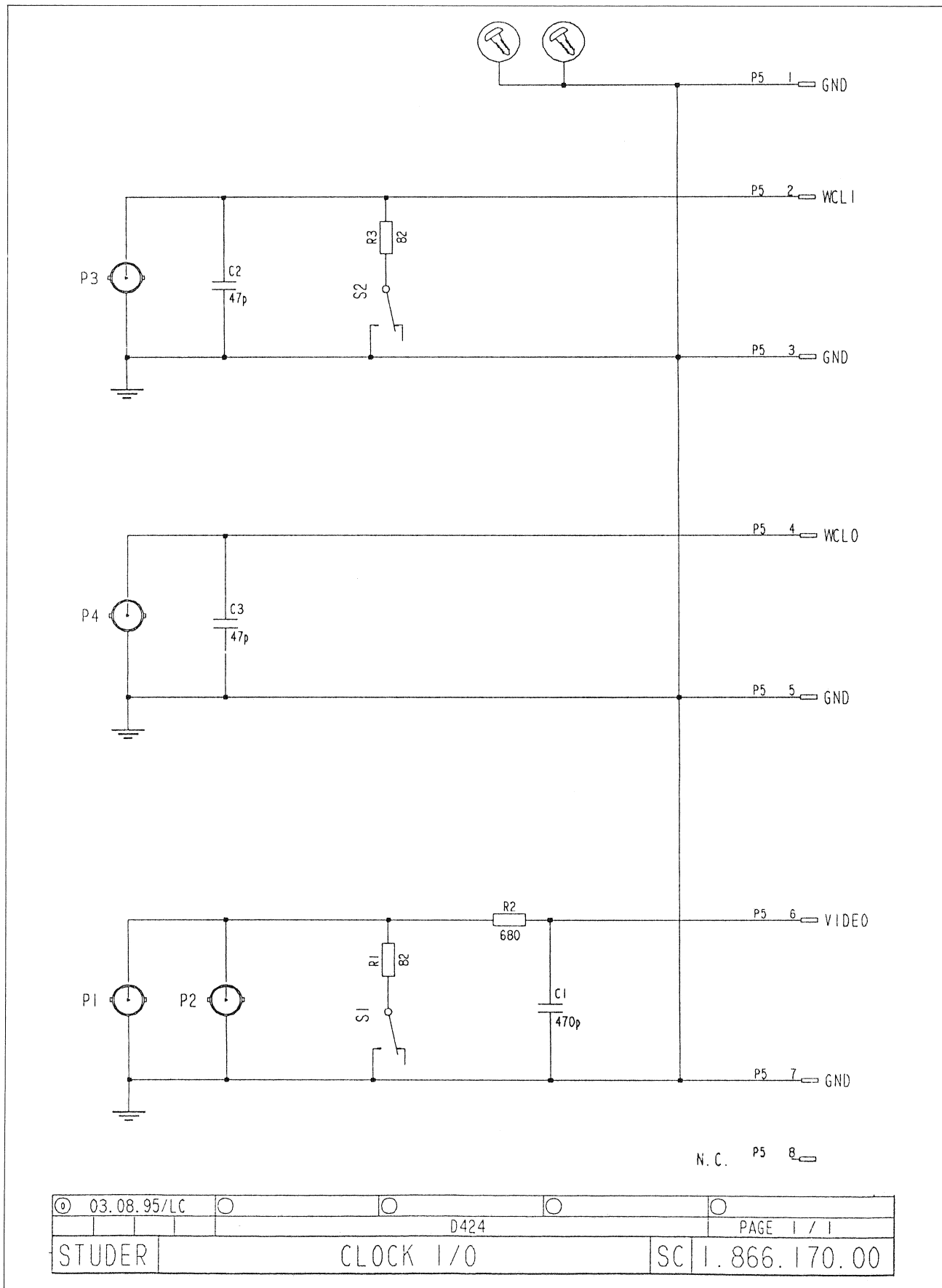

**Clock Input / Output 1.866.170.00**

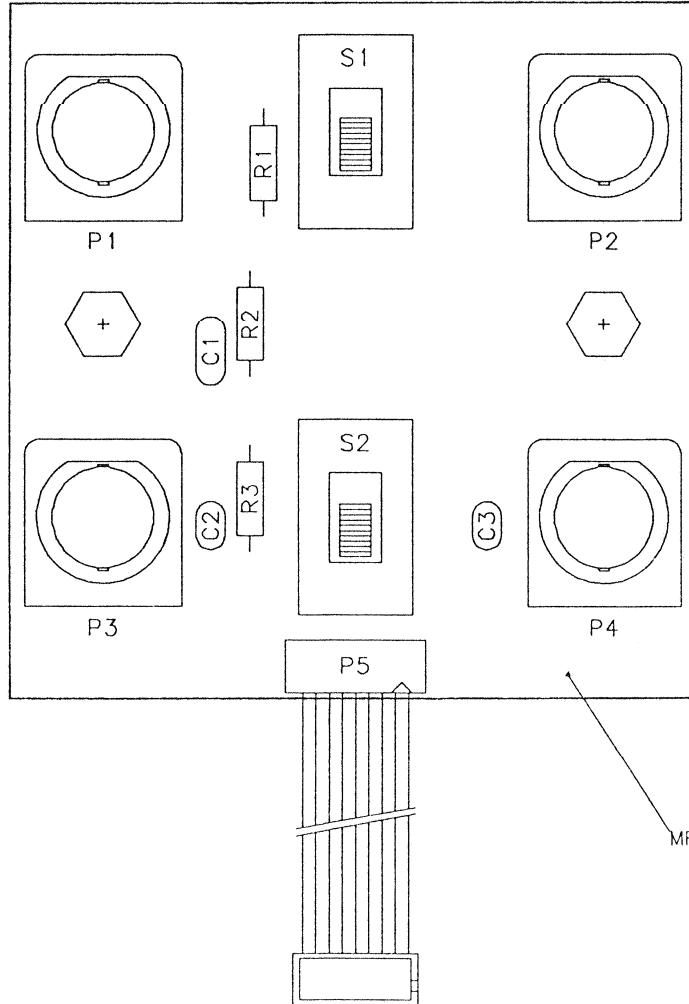

Idx.	Pos.	Part No.	Qty.	Type/Val.	Description
0	C 1	59.34.5471		470p	CER 63V, 5%, N1500
0	C 2	59.34.2470		47p	CER 63V, 5%, N150
0	C 3	59.34.2470		47p	CER 63V, 5%, N150
0	MP 1	1.866.170.10			NR. LABEL
1	MP 2	1.866.170.12			CLOCK I/O PCB
0	MP 3	20.24.7280	8 pcs		LIN-FORMSCH.ZNSW,KS D2.5* 8
0	MP 4	1.010.046	22 2 pcs		NIETMUTTER
0	P 1	54.21.2020		BNC	J 1 POL PRINT/CHASSIS BNC
0	P 2	54.21.2020		BNC	J 1 POL PRINT/CHASSIS BNC
0	P 3	54.21.2020		BNC	J 1 POL PRINT/CHASSIS BNC
0	P 4	54.21.2020		BNC	J 1 POL PRINT/CHASSIS BNC
0	P 5	1.023.390.10			FLACHKABEL 8 POL 0,1M
0	R 1	57.11.3820		82R	MF, 1%, 0207
0	R 2	57.11.3681		680R	MF, 1%, 0207
0	R 3	57.11.3820		82R	MF, 1%, 0207
0	S 1	55.12.0004			S SCHIEBE,1*4U, PRINT
0	S 2	55.12.0004			S SCHIEBE,1*4U, PRINT

End of List

**Comments:**

Layoutaenderung: Bei 1.866.170-12 Schalterstellung ON-OFF getauscht.

**STUDER**  
REGENSDORF  
Description  
German: CLOCK I/O

Revision	22.01.96	LC							
Date									
Drawn									
Checked									
Approved									
Index									
Copy to:	Exp. e. fuer: .....								
Number:	1.866.170-00								





Phones Board 1.865.160.00

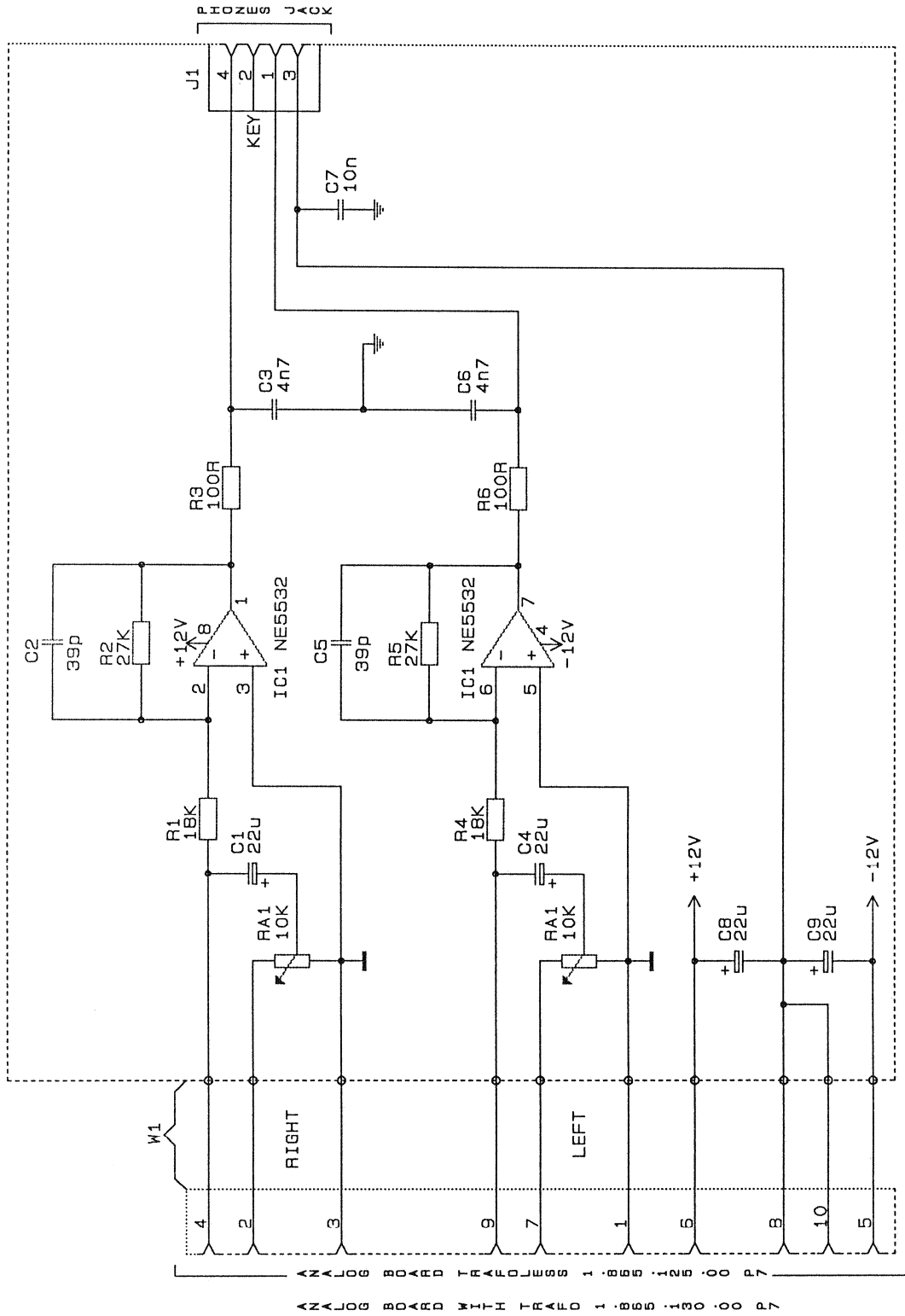

© 26.2.91 SB				
	R-DAT			PAGE 1 OF 1
<b>STUDER</b>	PHONES BOARD	A	SC	1.865.160.00



**Phones Board 1.865.160.00**

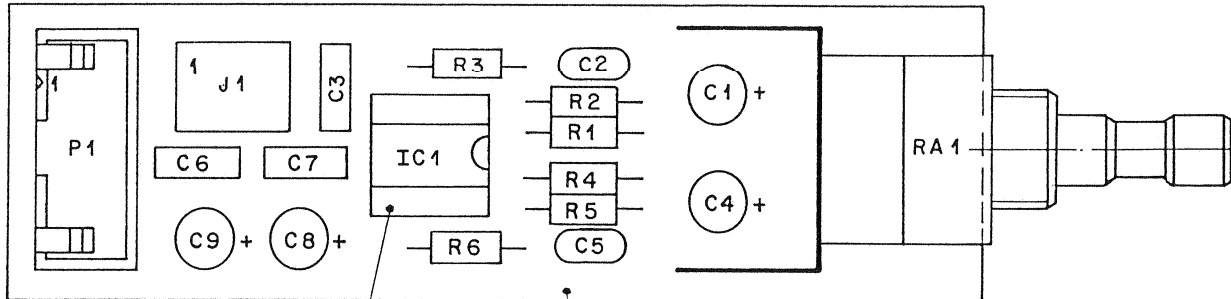

XIC 1

PCB 1

Änderung									
Ausgabe	25.2.92								
Datum	Gez.	Gepr.	Ges.	Index					

Kopie für:

STUDER REGENSDORF ZÜRICH	Beschreibung	<b>PHONES BOARD ESE</b>	Nummer:	<b>1.865.160-00</b>

Idx.	Pos.	Part No.	Qty.	Type/Val.	Description
0	C 1	59.22.5220		22u	EL 25V, 20%, RM5
0	C 2	59.34.2390		39p	CER 63V, 5%, N150
0	C 3	59.06.0472		4n7	PETP, 63V, 10%, RM5
0	C 4	59.22.5220		22u	EL 25V, 20%, RM5
0	C 5	59.34.2390		39p	CER 63V, 5%, N150
0	C 6	59.06.0472		4n7	PETP, 63V, 10%, RM5
0	C 7	59.06.0103		10n	PETP, 63V, 10%, RM5
0	C 8	59.22.5220		22u	EL 25V, 20%, RM5
0	C 9	59.22.5220		22u	EL 25V, 20%, RM5
0	IC 1	50.09.0105		NE5532N	IC NE 5532 N, RC 5532 NB ,A
0	J 1	54.01.0298		4-P	J LEISTE 4 POL CIS DURCHS
0	MP 1	1.865.160.01	1 pce		NR -ETIKETTE 5 * 20
0	MP 2	43.01.0108	1 pce	Label	ESE-WARNSCHILD
0	P 1	54.14.2101		10p	P STECKER 10 P,AU,VR,GERADE
0	PCB 1	1.865.160.11			PHONES PCB
0	R 1	57.11.3183		18k	MF, 1%, 0207
0	R 2	57.11.3273		27k	MF, 1%, 0207
0	R 3	57.11.3101		100R	MF, 1%, 0207
0	R 4	57.11.3183		18k	MF, 1%, 0207
0	R 5	57.11.3273		27k	MF, 1%, 0207
0	R 6	57.11.3101		100R	MF, 1%, 0207
0	RA 1	1.775.350.01			POTENTIOMETER MONITOR PHONES
0	XIC 1	53.03.0166		8p	DIL 0.3", lot, gerade

End of List

**Comments:**

CER=ceramic, EL=electrolytic, MF=metal film, PETP=polyester



Remote Keyboard 1.866.510.00 (Option)

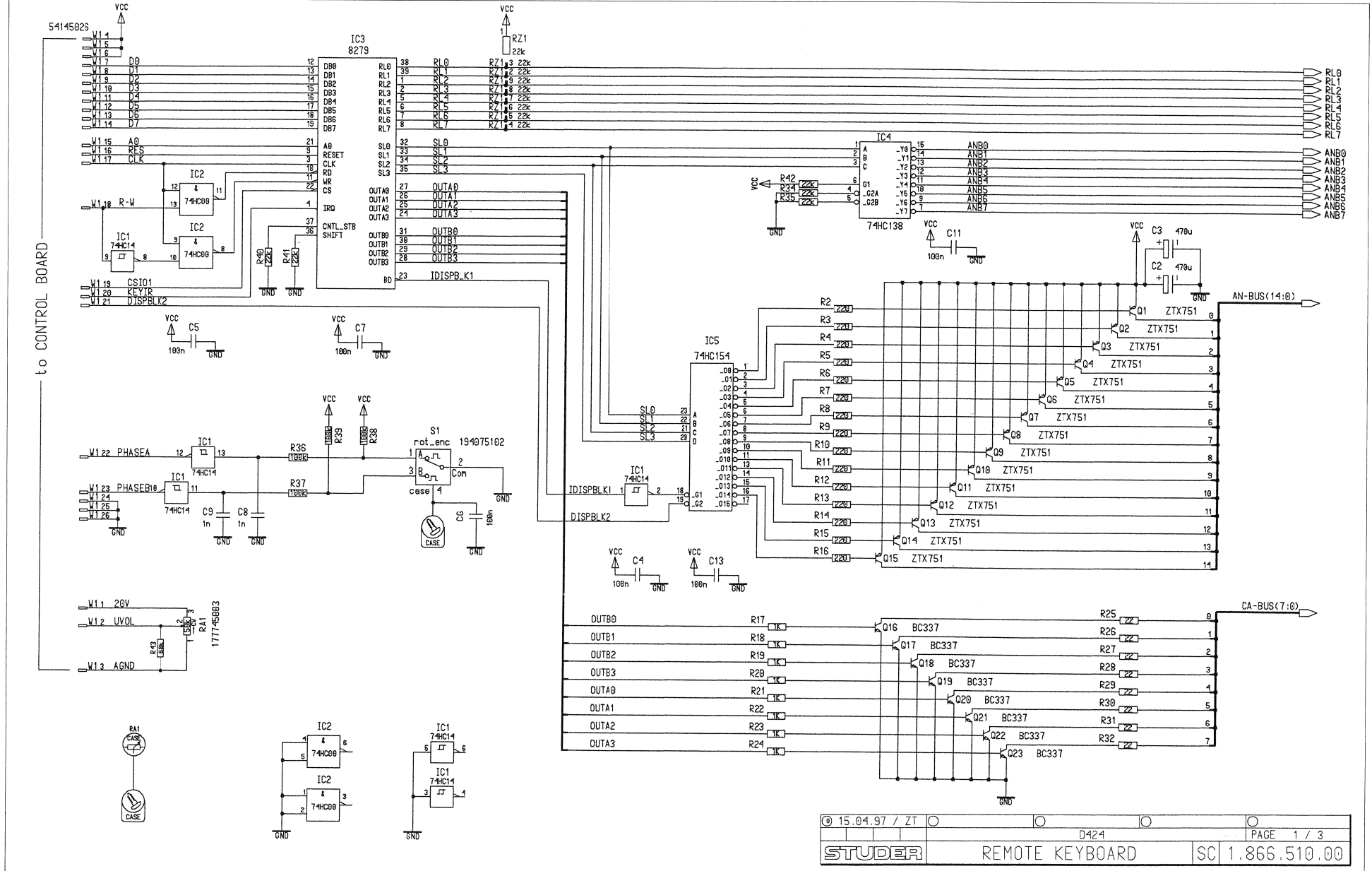



Remote Keyboard 1.866.510.00 (Option)

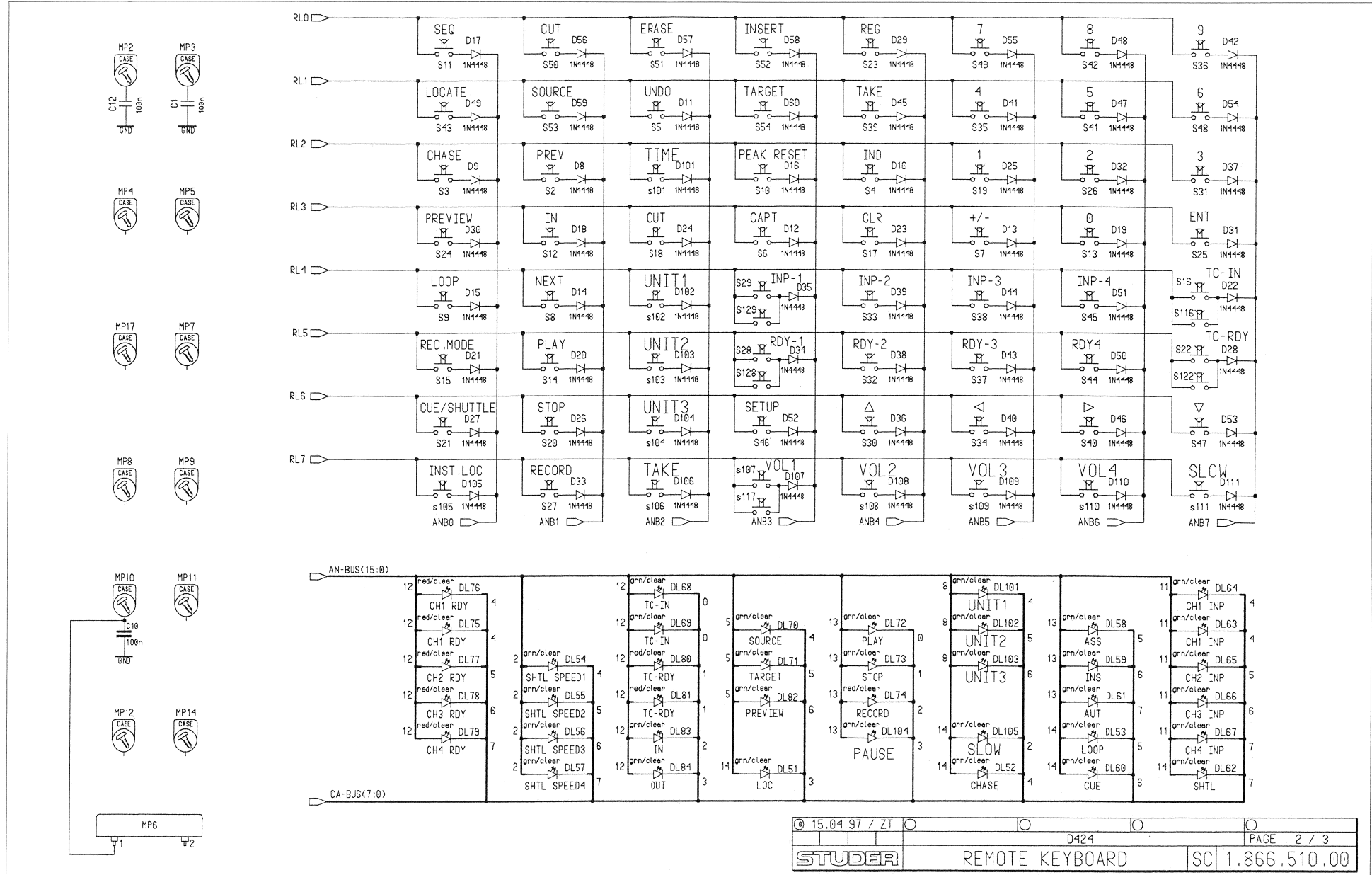



Remote Keyboard 1.866.510.00 (Option)

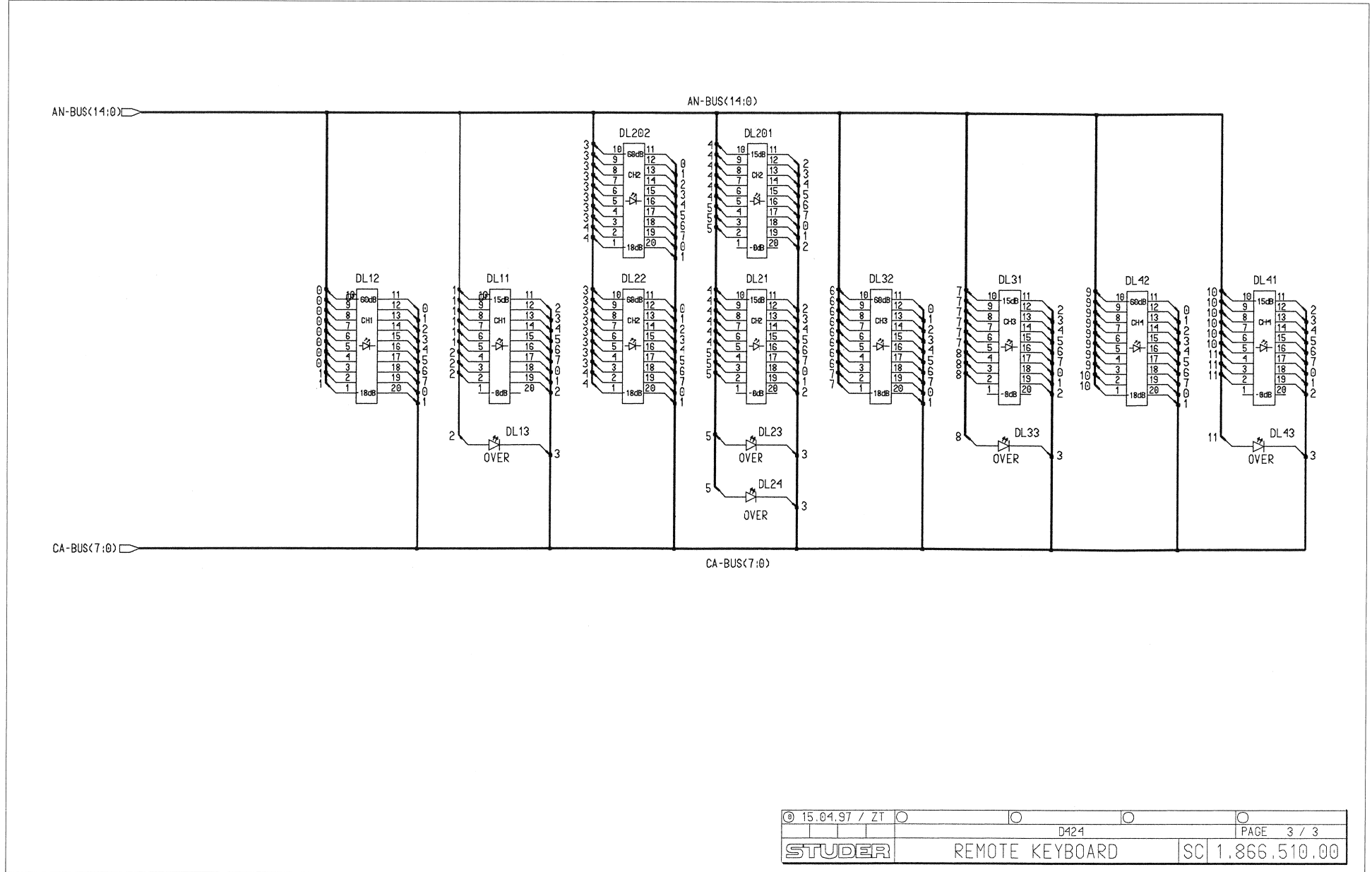



Remote Keyboard 1.866.510.00 (Option)

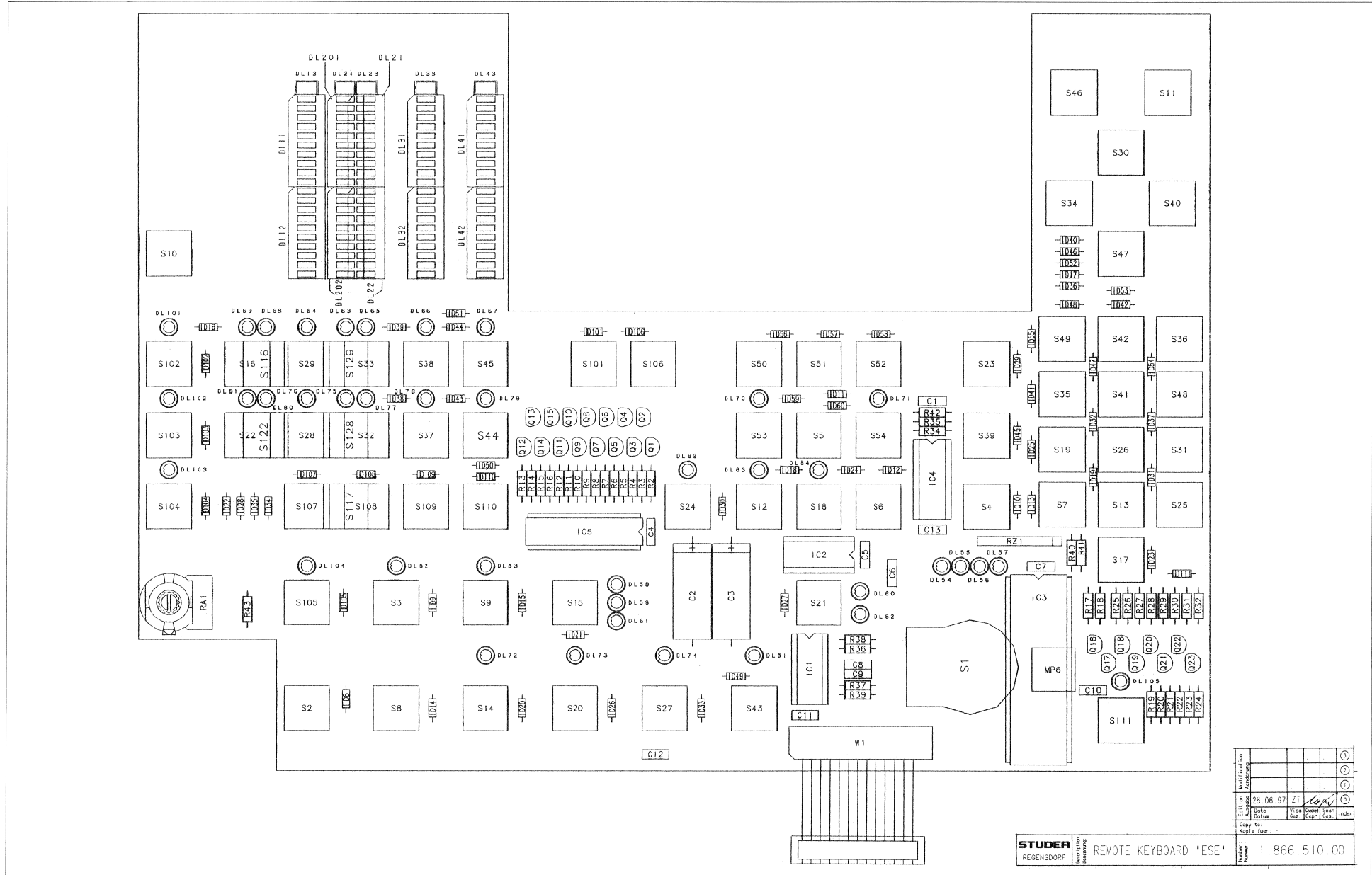

STUDER  
REGENSDORF

REWRITE KEYBOARD "ESE"  
1.866.510.00

Execution	26.06.97	ZT				
Address						
Copy to:						
Agilia fuer:						



Remote Keyboard I.866.510.00 (Option)

Idx.	Pos.	Part No.	Qty.	Type/Val.	Description	Idx.	Pos.	Part No.	Qty.	Type/Val.	Description
0	C 1	59.06.0104	100n		PETP, 63V, 10%, RM5	0	DL 33	50.04.2119		MV57124A	DL MV 57124 A, RT
0	C 2	59.25.3471	470u		C-EL, 20%, 16V	0	DL 41	not used		GRN	DLZ MV 54 164,LTA1000G 10*D GN
0	C 3	59.25.3471	470u		C-EL, 20%, 16V	0	DL 42	not used		GRN	DLZ MV 54 164,LTA1000G 10*D GN
0	C 4	59.06.0104	100n		PETP, 63V, 10%, RM5	0	DL 43	not used		MV57124A	DL MV 57124 A, RT
0	C 5	59.06.0104	100n		PETP, 63V, 10%, RM5	0	DL 51	50.04.2162		HLMP1540	LED 3mm, grün klar
0	C 6	59.06.0104	100n		PETP, 63V, 10%, RM5	0	DL 52	50.04.2162		HLMP1540	LED 3mm, grün klar
0	C 7	59.06.0104	100n		PETP, 63V, 10%, RM5	0	DL 53	50.04.2162		HLMP1540	LED 3mm, grün klar
0	C 8	59.06.0102	1n0		PETP, 63V, 10%, RM5	0	DL 54	50.04.2162		HLMP1540	LED 3mm, grün klar
0	C 9	59.06.0102	1n0		PETP, 63V, 10%, RM5	0	DL 55	50.04.2162		HLMP1540	LED 3mm, grün klar
0	C 10	59.06.0104	100n		PETP, 63V, 10%, RM5	0	DL 56	50.04.2162		HLMP1540	LED 3mm, grün klar
0	C 11	59.06.0104	100n		PETP, 63V, 10%, RM5	0	DL 57	50.04.2162		HLMP1540	LED 3mm, grün klar
0	C 12	59.06.0104	100n		PETP, 63V, 10%, RM5	0	DL 58	50.04.2162		HLMP1540	LED 3mm, grün klar
0	C 13	59.06.0104	100n		PETP, 63V, 10%, RM5	0	DL 59	50.04.2162		HLMP1540	LED 3mm, grün klar
0	D 8	50.04.0125	1N4448		75V, 150mA, 4ns, DO-35	0	DL 60	50.04.2162		HLMP1540	LED 3mm, grün klar
0	D 9	50.04.0125	1N4448		75V, 150mA, 4ns, DO-35	0	DL 61	50.04.2162		HLMP1540	LED 3mm, grün klar
0	D 10	50.04.0125	1N4448		75V, 150mA, 4ns, DO-35	0	DL 62	50.04.2162		HLMP1540	LED 3mm, grün klar
0	D 11	50.04.0125	1N4448		75V, 150mA, 4ns, DO-35	0	DL 63	50.04.2162		HLMP1540	LED 3mm, grün klar
0	D 12	50.04.0125	1N4448		75V, 150mA, 4ns, DO-35	0	DL 64	not used		HLMP1540	LED 3mm, grün klar
0	D 13	50.04.0125	1N4448		75V, 150mA, 4ns, DO-35	0	DL 65	not used		HLMP1540	LED 3mm, grün klar
0	D 14	50.04.0125	1N4448		75V, 150mA, 4ns, DO-35	0	DL 66	50.04.2162		HLMP1540	LED 3mm, grün klar
0	D 15	50.04.0125	1N4448		75V, 150mA, 4ns, DO-35	0	DL 67	not used		HLMP1540	LED 3mm, grün klar
0	D 16	50.04.0125	1N4448		75V, 150mA, 4ns, DO-35	0	DL 68	50.04.2162		HLMP1540	LED 3mm, grün klar
0	D 17	50.04.0125	1N4448		75V, 150mA, 4ns, DO-35	0	DL 69	not used		HLMP1540	LED 3mm, grün klar
0	D 18	50.04.0125	1N4448		75V, 150mA, 4ns, DO-35	0	DL 70	50.04.2162		HLMP1540	LED 3mm, grün klar
0	D 19	50.04.0125	1N4448		75V, 150mA, 4ns, DO-35	0	DL 71	50.04.2162		HLMP1540	LED 3mm, grün klar
0	D 20	50.04.0125	1N4448		75V, 150mA, 4ns, DO-35	0	DL 72	50.04.2162		HLMP1540	LED 3mm, grün klar
0	D 21	50.04.0125	1N4448		75V, 150mA, 4ns, DO-35	0	DL 73	50.04.2162		HLMP1540	LED 3mm, grün klar
0	D 22	50.04.0125	1N4448		75V, 150mA, 4ns, DO-35	0	DL 74	50.04.2159		HLMP1340	LED 3mm, rot klar
0	D 23	50.04.0125	1N4448		75V, 150mA, 4ns, DO-35	0	DL 75	50.04.2159		HLMP1340	LED 3mm, rot klar
0	D 24	50.04.0125	1N4448		75V, 150mA, 4ns, DO-35	0	DL 76	not used		HLMP1340	LED 3mm, rot klar
0	D 25	50.04.0125	1N4448		75V, 150mA, 4ns, DO-35	0	DL 77	not used		HLMP1340	LED 3mm, rot klar
0	D 26	50.04.0125	1N4448		75V, 150mA, 4ns, DO-35	0	DL 78	50.04.2159		HLMP1340	LED 3mm, rot klar
0	D 27	50.04.0125	1N4448		75V, 150mA, 4ns, DO-35	0	DL 79	not used		HLMP1340	LED 3mm, rot klar
0	D 28	50.04.0125	1N4448		75V, 150mA, 4ns, DO-35	0	DL 80	50.04.2159		HLMP1340	LED 3mm, rot klar
0	D 29	50.04.0125	1N4448		75V, 150mA, 4ns, DO-35	0	DL 81	not used		HLMP1340	LED 3mm, rot klar
0	D 30	50.04.0125	1N4448		75V, 150mA, 4ns, DO-35	0	DL 82	50.04.2162		HLMP1540	LED 3mm, grün klar
0	D 31	50.04.0125	1N4448		75V, 150mA, 4ns, DO-35	0	DL 83	50.04.2162		HLMP1540	LED 3mm, grün klar
0	D 32	50.04.0125	1N4448		75V, 150mA, 4ns, DO-35	0	DL 84	50.04.2162		HLMP1540	LED 3mm, grün klar
0	D 33	50.04.0125	1N4448		75V, 150mA, 4ns, DO-35	0	DL 101	50.04.2162		HLMP1540	LED 3mm, grün klar
0	D 34	50.04.0125	1N4448		75V, 150mA, 4ns, DO-35	0	DL 102	50.04.2162		HLMP1540	LED 3mm, grün klar
0	D 35	50.04.0125	1N4448		75V, 150mA, 4ns, DO-35	0	DL 103	50.04.2162		HLMP1540	LED 3mm, grün klar
0	D 36	50.04.0125	1N4448		75V, 150mA, 4ns, DO-35	0	DL 104	50.04.2162		HLMP1540	LED 3mm, grün klar
0	D 37	50.04.0125	1N4448		75V, 150mA, 4ns, DO-35	0	DL 105	50.04.2162		HLMP1540	LED 3mm, grün klar
0	D 38	50.04.0125	1N4448		75V, 150mA, 4ns, DO-35	0	DL 201	50.04.2161		GRN	DLZ MV 54 164,LTA1000G 10*D GN
0	D 39	50.04.0125	1N4448		75V, 150mA, 4ns, DO-35	0	DL 202	50.04.2161		GRN	DLZ MV 54 164,LTA1000G 10*D GN
0	D 40	50.04.0125	1N4448		75V, 150mA, 4ns, DO-35	0	IC 1	50.17.1014		74HC14	IC ... 74 HC 14 .. ,A
0	D 41	50.04.0125	1N4448		75V, 150mA, 4ns, DO-35	0	IC 2	50.17.1000		74HC00	IC ... 74 HC 00 .. ,A
0	D 42	50.04.0125	1N4448		75V, 150mA, 4ns, DO-35	0	IC 3	50.16.0111		8279	IC IP 8279-5, ID 8279-5,
0	D 43	50.04.0125	1N4448		75V, 150mA, 4ns, DO-35	0	IC 4	50.17.1138		74HC138	IC ... 74 HC 138 .. ,A
0	D 44	50.04.0125	1N4448		75V, 150mA, 4ns, DO-35	0	IC 5	50.17.1154		74HC154	4-to16 Line driver, DIP 24-300
0	D 45	50.04.0125	1N4448		75V, 150mA, 4ns, DO-35	0	MP 1	1.866.510.11	mp		REMOTE KEYBOARD PCB
0	D 46	50.04.0125	1N4448		75V, 150mA, 4ns, DO-35	0	MP 2	1.866.510.10	mp		NR. LABEL
0	D 47	50.04.0125	1N4448		75V, 150mA, 4ns, DO-35	0	MP 3	43.01.0108	mp	Label	ESE-WARNSCHILD
0	D 48	50.04.0125	1N4448		75V, 150mA, 4ns, DO-35	0	MP 4	1.865.140.03	31 pcs		DIODENABSTANDSHALTER
0	D 49	50.04.0125	1N4448		75V, 150mA, 4ns, DO-35	0	MP 5	53.03.0218	84 pcs	1p	XIC SINGLE, IN-LINE 1PIN=1STK
0	D 50	50.04.0125	1N4448		75V, 150mA, 4ns, DO-35	0	MP 6	1.866.510.01			Schirmblech
0	D 51	50.04.0125	1N4448		75V, 150mA, 4ns, DO-35	0	Q 1	50.03.0352		ZTX751S	ZTX 751 S
0	D 52	50.04.0125	1N4448		75V, 150mA, 4ns, DO-35	0	Q 2	50.03.0352		ZTX751S	ZTX 751 S
0	D 53	50.04.0125	1N4448		75V, 150mA, 4ns, DO-35	0	Q 3	50.03.0352		ZTX751S	ZTX 751 S
0	D 54	50.04.0125	1N4448		75V, 150mA, 4ns, DO-35	0	Q 4	50.03.0352		ZTX751S	ZTX 751 S
0	D 55	50.04.0125	1N4448		75V, 150mA, 4ns, DO-35	0	Q 5	50.03.0352		ZTX751S	ZTX 751 S
0	D 56	50.04.0125	1N4448		75V, 150mA, 4ns, DO-35	0	Q 6	50.03.0352		ZTX751S	ZTX 751 S
0	D 57	50.04.0125	1N4448		75V, 150mA, 4ns, DO-35	0	Q 7	50.03.0352		ZTX751S	ZTX 751 S
0	D 58	50.04.0125	1N4448		75V, 150mA, 4ns, DO-35	0	Q 8	50.03.0352		ZTX751S	ZTX 751 S
0	D 59	50.04.0125	1N4448		75V, 150mA, 4ns, DO-35	0	Q 9	50.03.0352		ZTX751S	ZTX 751 S
0	D 60	50.04.0125	1N4448		75V, 150mA, 4ns, DO-35	0	Q 10	50.03.0352		ZTX751S	ZTX 751 S
0	D 101	50.04.0125	1N4448		75V, 150mA, 4ns, DO-35	0	Q 11	50.03.0352		ZTX751S	ZTX 751 S
0	D 102	50.04.0125	1N4448		75V, 150mA, 4ns, DO-35	0	Q 12	50.03.0352		ZTX751S	ZTX 751 S
0	D 103	50.04.0125	1N4448		75V, 150mA, 4ns, DO-35	0	Q 13	50.03.0352		ZTX751S	ZTX 751 S
0	D 104	50.04.0125	1N4448		75V, 150mA, 4ns, DO-35	0	Q 14	50.03.0352		ZTX751S	ZTX 751 S
0	D 105	50.04.0125	1N4448		75V, 150mA, 4ns, DO-35	0	Q 15	50.03.0352		ZTX751S	ZTX 751 S
0	D 106	50.04.0125	1N4448		75V, 150mA, 4ns, DO-35	0	Q 16	50.03.0340		BC337-25	800mA, 45V, NPN
0	D 107	50.04.0125	1N4448		75V, 150mA, 4ns, DO-35	0	Q 17	50.03.0340		BC337-25	800mA, 45V, NPN
0	D 108	50.04.0125	1N4448		75V, 150mA, 4ns, DO-35	0	Q 18	50.03.0340		BC337-25	800mA, 45V, NPN
0	D 109	50.04.0125	1N4448		75V, 150mA, 4ns, DO-35	0	Q 19	50.03.0340		BC337-25	800mA, 45V, NPN
0	D 110	50.04.0125	1N4448		75V, 150mA, 4ns, DO-35	0	Q 20	50.03.0340		BC337-25	800mA, 45V, NPN
0	D 111	50.04.0125	1N4448		75V, 150mA, 4ns, DO-35	0	Q 21	50.03.0340		BC337-25	800mA, 45V, NPN
0	DL 11	not used	GRN		DLZ MV 54 164,LTA1000G 10*D GN	0	Q 22	50.03.0340		BC337-25	800mA, 45V, NPN
0	DL 12	not used	GRN		DLZ MV 54 164,LTA1000G 10*D GN	0	Q 23	50.03.0340		BC337-25	800mA, 45V, NPN
0	DL 13	not used	MV57124A		DL MV 57124 A, RT	0	R 2	57.11.3221		220R	MF, 1%, 0207
0	DL 21	not used	GRN		DLZ MV 54 164,LTA1000G 10*D GN	0	R 3	57.11.3221		220R	MF, 1%, 0207
0	DL 22	not used	GRN		DLZ MV 54 164,LTA1000G 10*D GN	0	R 4	57.11.3221		220R	MF, 1%, 0207
0	DL 23	not used	MV57124A		DL MV 57124 A, RT	0	R 5	57.11.3221		220R	MF, 1%, 0207
0	DL 24	50.04.2119	MV57124A		DL MV 57124 A, RT	0	R 6	57.11.3221		220R	MF, 1%, 0207
0	DL 31	50.04.2161	GRN		DLZ MV 54 164,LTA1000G 10*D GN						
0	DL 32	50.04.2161	GRN		DLZ MV 54 164,LTA1000G 10*D GN						



Remote Keyboard 1.866.510.00 (Option)

Idx.	Pos.	Part No.	Qty.	Type/Val.	Description	Idx.	Pos.	Part No.	Qty.	Type/Val.	Description
0	R 7	57.11.3221		220R	MF, 1%, 0207	0	S 48	55.99.0158		1*a	S IMPULS - DRUCKTASTENSCH.
0	R 8	57.11.3221		220R	MF, 1%, 0207	0	S 49	55.99.0158		1*a	S IMPULS - DRUCKTASTENSCH.
0	R 9	57.11.3221		220R	MF, 1%, 0207	0	S 50	55.99.0158		1*a	S IMPULS - DRUCKTASTENSCH.
0	R 10	57.11.3221		220R	MF, 1%, 0207	0	S 51	55.99.0158		1*a	S IMPULS - DRUCKTASTENSCH.
0	R 11	57.11.3221		220R	MF, 1%, 0207	0	S 52	55.99.0158		1*a	S IMPULS - DRUCKTASTENSCH.
0	R 12	57.11.3221		220R	MF, 1%, 0207	0	S 53	55.99.0158		1*a	S IMPULS - DRUCKTASTENSCH.
0	R 13	57.11.3221		220R	MF, 1%, 0207	0	S 54	55.99.0158		1*a	S IMPULS - DRUCKTASTENSCH.
0	R 14	57.11.3221		220R	MF, 1%, 0207	0	S 101	55.99.0158		1*a	S IMPULS - DRUCKTASTENSCH.
0	R 15	57.11.3221		220R	MF, 1%, 0207	0	S 102	55.99.0158		1*a	S IMPULS - DRUCKTASTENSCH.
0	R 16	57.11.3221		220R	MF, 1%, 0207	0	S 103	55.99.0158		1*a	S IMPULS - DRUCKTASTENSCH.
0	R 17	57.11.3102		1k0	MF, 1%, 0207	0	S 104	55.99.0158		1*a	S IMPULS - DRUCKTASTENSCH.
0	R 18	57.11.3102		1k0	MF, 1%, 0207	0	S 105	55.99.0158		1*a	S IMPULS - DRUCKTASTENSCH.
0	R 19	57.11.3102		1k0	MF, 1%, 0207	0	S 106	55.99.0158		1*a	S IMPULS - DRUCKTASTENSCH.
0	R 20	57.11.3102		1k0	MF, 1%, 0207	0	S 107	not used		1*a	S IMPULS - DRUCKTASTENSCH.
0	R 21	57.11.3102		1k0	MF, 1%, 0207	0	S 108	not used		1*a	S IMPULS - DRUCKTASTENSCH.
0	R 22	57.11.3102		1k0	MF, 1%, 0207	0	S 109	55.99.0158		1*a	S IMPULS - DRUCKTASTENSCH.
0	R 23	57.11.3102		1k0	MF, 1%, 0207	0	S 110	not used		1*a	S IMPULS - DRUCKTASTENSCH.
0	R 24	57.11.3102		1k0	MF, 1%, 0207	0	S 111	55.99.0158		1*a	S IMPULS - DRUCKTASTENSCH.
0	R 25	57.11.3220		22R	MF, 1%, 0207	0	S 116	55.99.0158		1*a	S IMPULS - DRUCKTASTENSCH.
0	R 26	57.11.3220		22R	MF, 1%, 0207	0	S 117	55.99.0158		1*a	S IMPULS - DRUCKTASTENSCH.
0	R 27	57.11.3220		22R	MF, 1%, 0207	0	S 122	55.99.0158		1*a	S IMPULS - DRUCKTASTENSCH.
0	R 28	57.11.3220		22R	MF, 1%, 0207	0	S 128	55.99.0158		1*a	S IMPULS - DRUCKTASTENSCH.
0	R 29	57.11.3220		22R	MF, 1%, 0207	0	S 129	55.99.0158		1*a	S IMPULS - DRUCKTASTENSCH.
0	R 30	57.11.3220		22R	MF, 1%, 0207						
0	R 31	57.11.3220		22R	MF, 1%, 0207						
0	R 32	57.11.3220		22R	MF, 1%, 0207						
0	R 34	57.11.3223		22k	MF, 1%, 0207						
0	R 35	57.11.3223		22k	MF, 1%, 0207						
0	R 36	57.11.3104		100k	MF, 1%, 0207						
0	R 37	57.11.3104		100k	MF, 1%, 0207						
0	R 38	57.11.3104		100k	MF, 1%, 0207						
0	R 39	57.11.3104		100k	MF, 1%, 0207						
0	R 40	57.11.3223		22k	MF, 1%, 0207						
0	R 41	57.11.3223		22k	MF, 1%, 0207						
0	R 42	57.11.3223		22k	MF, 1%, 0207						
0	R 43	57.11.3683		68k	MF, 1%, 0207						
0	RA 1	1.777.450.03			ROTARY POTENTIOMETER 50 KB						
0	RZ 1	57.88.4223		8*22k	2%, SIP 9						
0	S 1	1.940.751.02			ROTARY ENCODER						
0	S 2	55.99.0158		1*a	S IMPULS - DRUCKTASTENSCH.						
0	S 3	55.99.0158		1*a	S IMPULS - DRUCKTASTENSCH.						
0	S 4	55.99.0158		1*a	S IMPULS - DRUCKTASTENSCH.						
0	S 5	55.99.0158		1*a	S IMPULS - DRUCKTASTENSCH.						
0	S 6	55.99.0158		1*a	S IMPULS - DRUCKTASTENSCH.						
0	S 7	55.99.0158		1*a	S IMPULS - DRUCKTASTENSCH.						
0	S 8	55.99.0158		1*a	S IMPULS - DRUCKTASTENSCH.						
0	S 9	55.99.0158		1*a	S IMPULS - DRUCKTASTENSCH.						
0	S 10	55.99.0158		1*a	S IMPULS - DRUCKTASTENSCH.						
0	S 11	55.99.0158		1*a	S IMPULS - DRUCKTASTENSCH.						
0	S 12	55.99.0158		1*a	S IMPULS - DRUCKTASTENSCH.						
0	S 13	55.99.0158		1*a	S IMPULS - DRUCKTASTENSCH.						
0	S 14	55.99.0158		1*a	S IMPULS - DRUCKTASTENSCH.						
0	S 15	55.99.0158		1*a	S IMPULS - DRUCKTASTENSCH.						
0	S 16	not used		1*a	S IMPULS - DRUCKTASTENSCH.						
0	S 17	55.99.0158		1*a	S IMPULS - DRUCKTASTENSCH.						
0	S 18	55.99.0158		1*a	S IMPULS - DRUCKTASTENSCH.						
0	S 19	55.99.0158		1*a	S IMPULS - DRUCKTASTENSCH.						
0	S 20	55.99.0158		1*a	S IMPULS - DRUCKTASTENSCH.						
0	S 21	55.99.0158		1*a	S IMPULS - DRUCKTASTENSCH.						
0	S 22	not used		1*a	S IMPULS - DRUCKTASTENSCH.						
0	S 23	55.99.0158		1*a	S IMPULS - DRUCKTASTENSCH.						
0	S 24	55.99.0158		1*a	S IMPULS - DRUCKTASTENSCH.						
0	S 25	55.99.0158		1*a	S IMPULS - DRUCKTASTENSCH.						
0	S 26	55.99.0158		1*a	S IMPULS - DRUCKTASTENSCH.						
0	S 27	55.99.0158		1*a	S IMPULS - DRUCKTASTENSCH.						
0	S 28	not used		1*a	S IMPULS - DRUCKTASTENSCH.						
0	S 29	not used		1*a	S IMPULS - DRUCKTASTENSCH.						
0	S 30	55.99.0158		1*a	S IMPULS - DRUCKTASTENSCH.						
0	S 31	55.99.0158		1*a	S IMPULS - DRUCKTASTENSCH.						
0	S 32	not used		1*a	S IMPULS - DRUCKTASTENSCH.						
0	S 33	not used		1*a	S IMPULS - DRUCKTASTENSCH.						
0	S 34	55.99.0158		1*a	S IMPULS - DRUCKTASTENSCH.						
0	S 35	55.99.0158		1*a	S IMPULS - DRUCKTASTENSCH.						
0	S 36	55.99.0158		1*a	S IMPULS - DRUCKTASTENSCH.						
0	S 37	55.99.0158		1*a	S IMPULS - DRUCKTASTENSCH.						
0	S 38	55.99.0158		1*a	S IMPULS - DRUCKTASTENSCH.						
0	S 39	55.99.0158		1*a	S IMPULS - DRUCKTASTENSCH.						
0	S 40	55.99.0158		1*a	S IMPULS - DRUCKTASTENSCH.						
0	S 41	55.99.0158		1*a	S IMPULS - DRUCKTASTENSCH.						
0	S 42	55.99.0158		1*a	S IMPULS - DRUCKTASTENSCH.						
0	S 43	55.99.0158		1*a	S IMPULS - DRUCKTASTENSCH.						
0	S 44	not used		1*a	S IMPULS - DRUCKTASTENSCH.						
0	S 45	not used		1*a	S IMPULS - DRUCKTASTENSCH.						
0	S 46	55.99.0158		1*a	S IMPULS - DRUCKTASTENSCH.						
0	S 47	55.99.0158		1*a	S IMPULS - DRUCKTASTENSCH.						
						0	W 1	1.023.112.07		Ribbon26p	FLACHKABEL 26 POL. 0,13M

End of List

Comments:



Remote Control 1.866.520.20 (Option)

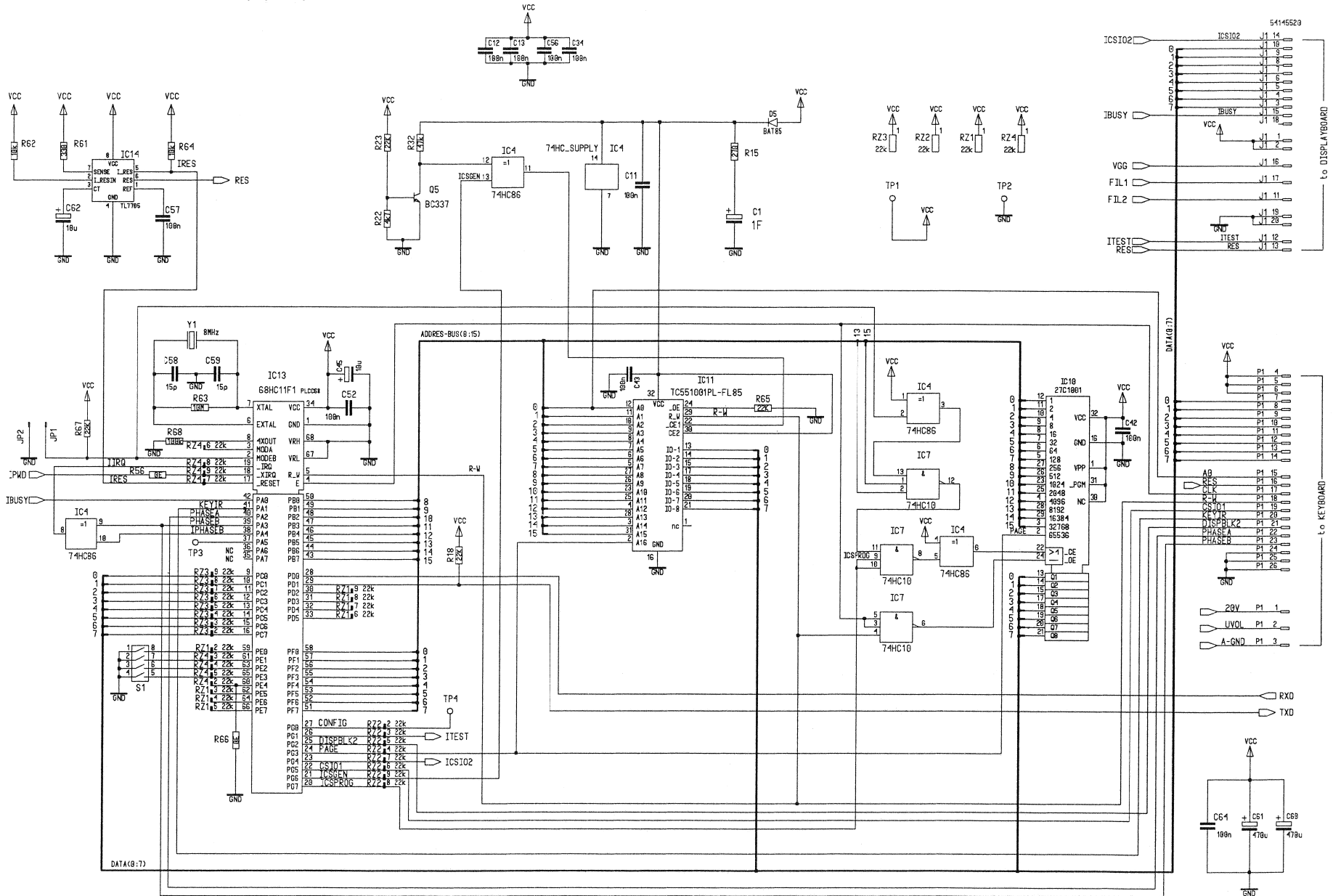



Remote Control 1.866.520.20 (Option)

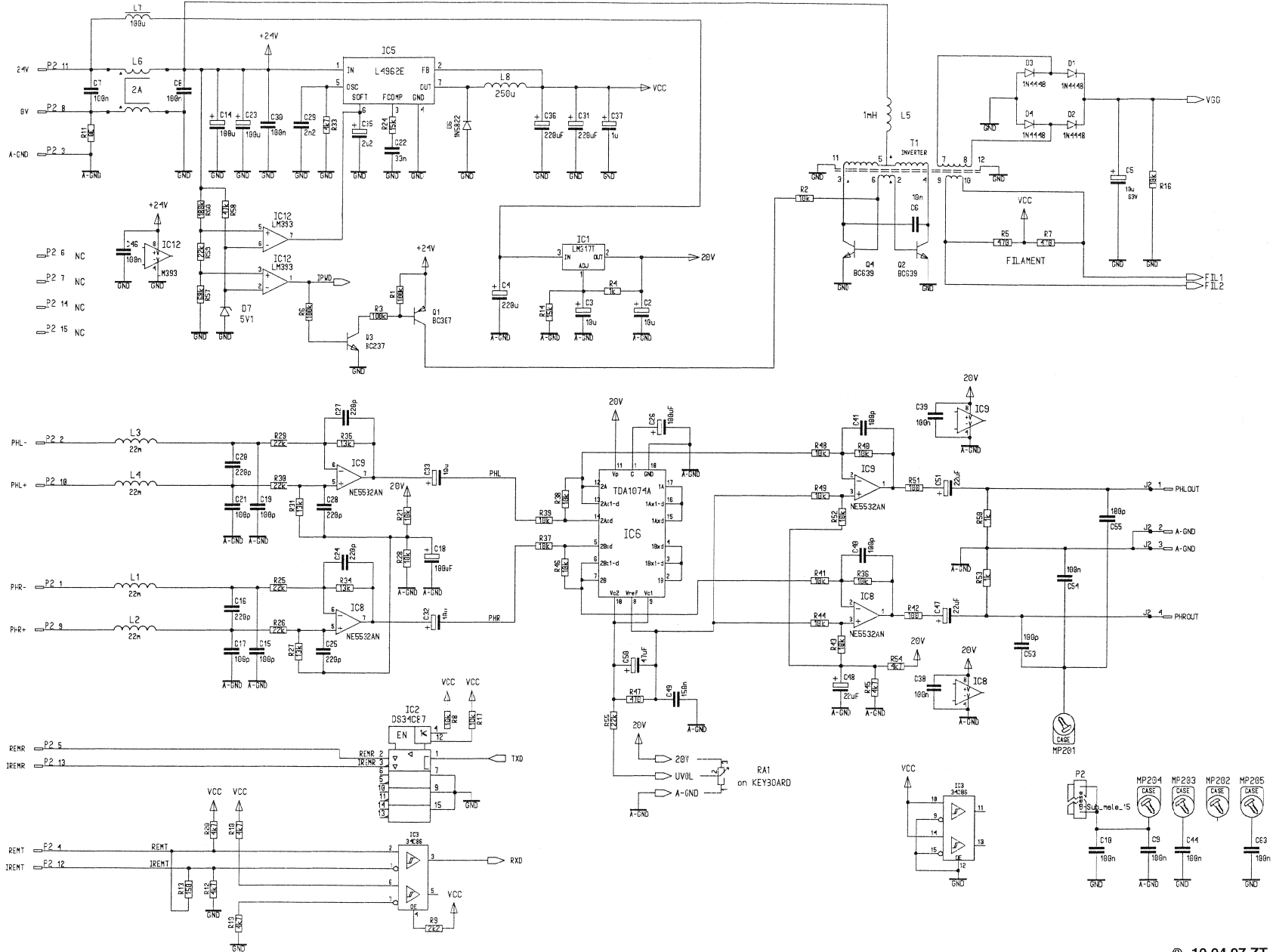

Remote Control 1.866.520.20 (Option)

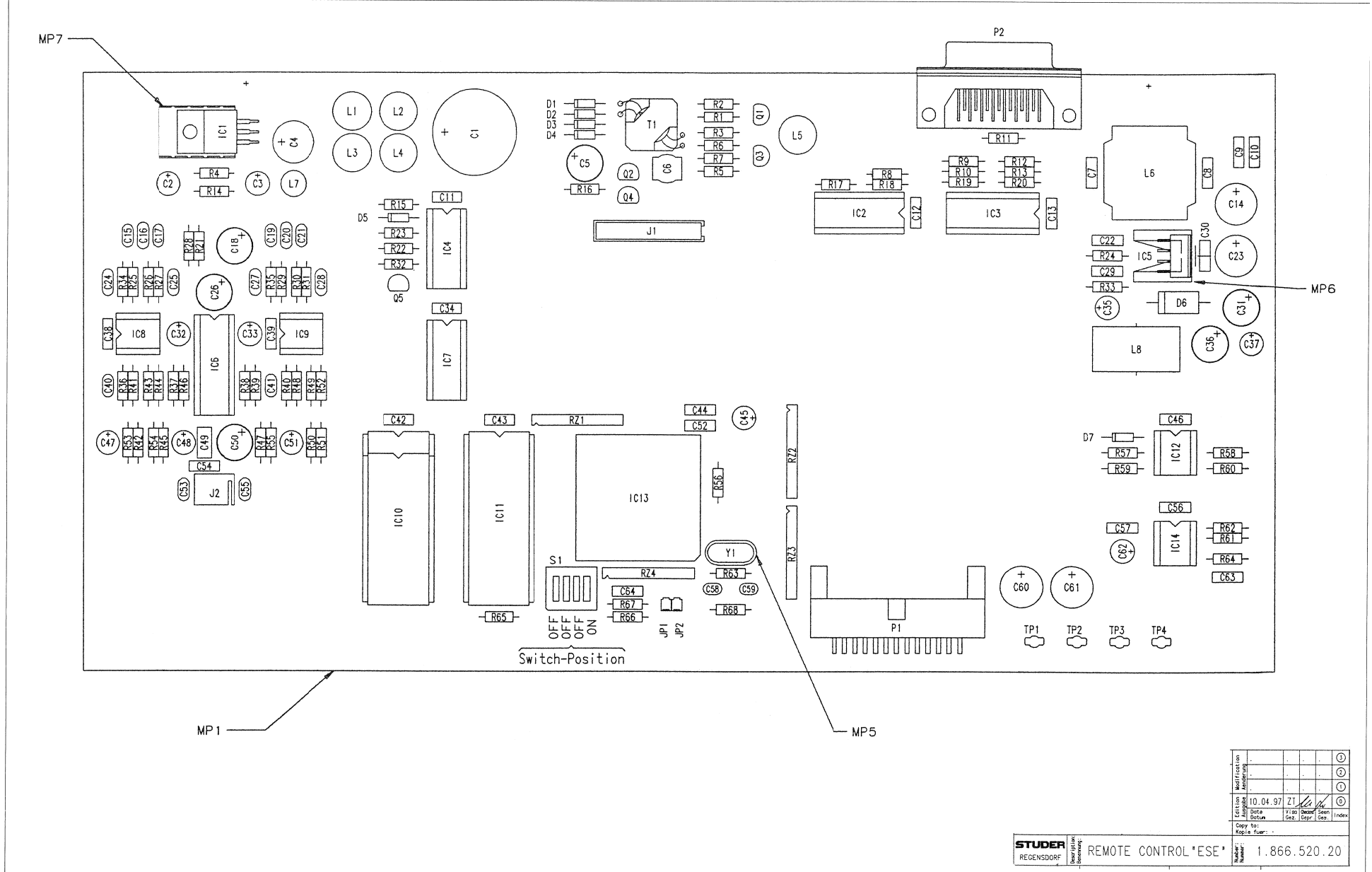

Edizyon	Modifikasyon				
№	Assistans				
10.04.97	ZI				



Remote Control 1.866.520.20 (Option)

Idx. Pos.	Part No.	Qty.	Type/Val.	Description	Idx. Pos.	Part No.	Qty.	Type/Val.	Description	Idx. Pos.	Part No.	Qty.	Type/Val.	Description
0 C 1	59.22.1105	1F	EL	5.5V, 20%, rad	0 J 1	54.14.5520	20p	J	PCB-BUCHSE GERADE 20 P	0 R 57	57.11.3083	68k	MF	1%, 0207
0 C 2	59.22.6100	10u	EL	35V, 20%, RM5	0 J 2	54.01.0304	4-P	J	LEISTE 4 POL CIS PARLEL	0 R 58	57.11.3473	47k	MF	1%, 0207
0 C 3	59.22.6100	10u	EL	35V, 20%, RM5						0 R 59	57.11.3223	22k	MF	1%, 0207
0 C 4	59.22.6221	220u	EL	40V, 20%, RM5	0 JP 1			not used		0 R 60	57.11.3184	180k	MF	1%, 0207
0 C 5	59.22.8100	10u	EL	63V, 20%, RM5	0 JP 2			not used		0 R 61	57.11.3331	330R	MF	1%, 0207
0 C 6	59.05.2103	10n	PP	2,5%, 63V	0 L 1	62.02.3223	22mH	L	22 M., 10%, RAD., RM 5	0 R 62	57.11.3103	10k	MF	1%, 0207
0 C 7	59.06.0104	100n	PETP	63V, 10%, RM5	0 L 2	62.02.3223	22mH	L	22 M., 10%, RAD., RM 5	0 R 63	57.11.5106	10M	MF	5%, 0207
0 C 8	59.06.0104	100n	PETP	63V, 10%, RM5	0 L 3	62.02.3223	22mH	L	22 M., 10%, RAD., RM 5	0 R 64	57.11.3103	10k	MF	1%, 0207
0 C 9	59.06.0104	100n	PETP	63V, 10%, RM5	0 L 4	62.02.3223	22mH	L	22 M., 10%, RAD., RM 5	0 R 65	57.11.3223	22k	MF	1%, 0207
0 C 10	59.06.0104	100n	PETP	63V, 10%, RM5	0 L 5	62.02.3102	1mH	L	1 M., 10%, RAD., RM 5	0 R 66	57.11.3000	0R0	MF	0207
0 C 11	59.06.0104	100n	PETP	63V, 10%, RM5	0 L 6	62.03.0100	1.5mH	2A	Toroid Core compensated	0 R 67	57.11.3223	22k	MF	1%, 0207
0 C 12	59.06.0104	100n	PETP	63V, 10%, RM5	0 L 7	62.02.3101	100uH	L	100 U., 10%, RAD., RM 5	0 R 68	57.11.3104	100k	MF	1%, 0207
0 C 13	59.06.0104	100n	PETP	63V, 10%, RM5	0 L 8	62.03.0025	250uH	2A	Toroid Choche	0 RZ 1	57.88.4223	8*22k	2%	SIP 9
0 C 14	59.22.6101	100u	EL	40V, 20%, RM5						0 RZ 2	57.88.4223	8*22k	2%	SIP 9
0 C 15	59.34.4101	100p	CER	63V, 5%, N750	0 MP 1	1.866.520.11			REMOTE CONTROL PCB	0 RZ 3	57.88.4223	8*22k	2%	SIP 9
0 C 16	59.34.4221	220p	CER	63V, 5%, N750	0 MP 2	1.866.520.10			NR LABEL	0 RZ 4	57.88.4223	8*22k	2%	SIP 9
0 C 17	59.34.4101	100p	CER	63V, 5%, N750	0 MP 3	1.101.001.20			Label					
0 C 18	59.22.5101	100u	EL	25V, 20%, RM5	0 MP 4	43.01.0108			Label					
0 C 19	59.34.4101	100p	CER	63V, 5%, N750	0 MP 5	89.01.1499			Label	0 S 1	55.01.0164	4'a	SZ	4'A, DIL
0 C 20	59.34.4221	220p	CER	63V, 5%, N750	0 MP 6	50.20.3004								
0 C 21	59.34.4101	100p	CER	63V, 5%, N750	0 MP 7	50.20.3004				0 T 1	1.022.653.00			TRAFO VF-DISPLAY
0 C 22	59.06.0133	33n	PETP	63V, 10%, RM5						0 TP 1	54.02.0320	1p		Flatpin, 2.8*0.8mm
0 C 23	59.22.6101	100u	EL	40V, 20%, RM5	0 P 1	54.14.2114	26p	1/20°	Au, winkel, Verriegelung	0 TP 2	54.02.0320	1p		Flatpin, 2.8*0.8mm
0 C 24	59.34.4221	220p	CER	63V, 5%, N750	0 P 2	54.13.0077	15p	D-Sub, PCB, Winkel		0 TP 3	54.02.0320	1p		Flatpin, 2.8*0.8mm
0 C 25	59.34.4221	220p	CER	63V, 5%, N750						0 TP 4	54.02.0320	1p		Flatpin, 2.8*0.8mm
0 C 26	59.22.5101	100u	EL	25V, 20%, RM5	0 Q 1	50.03.0515	BC307B	BC	307 B, BC 557 B, PNP	0 XIC 2	53.03.0108	16p		DIL 0.3", lot, gerade
0 C 27	59.34.4221	220p	CER	63V, 5%, N750	0 Q 2	50.03.0551	BC639	BC	639	0 XIC 3	53.03.0108	16p		DIL 0.3", lot, gerade
0 C 28	59.34.4221	220p	CER	63V, 5%, N750	0 Q 3	50.03.0436	BC237B	BC	237 B, 547 B, 550 B	0 XIC 10	53.03.0184	32p		DIL 0.6", lot, gerade
0 C 29	59.06.0222	2n2	PETP	63V, 10%, RM5	0 Q 4	50.03.0551	BC639	BC	639	0 XIC 13	53.03.2268	PLCC38p		PLCC-Socket 68p
0 C 30	59.06.0104	100n	PETP	63V, 10%, RM5	0 Q 5	50.03.0340	BC337-25	800nA	45V, NPN					
0 C 31	59.22.3221	220u	EL	10V, 20%, RM5	0 R 1	57.11.3104	100k	MF	1%, 0207	0 Y 1	85.01.1008	8.0000MHz	8.000.000 MHz	HC 18/U
0 C 32	59.22.6100	10u	EL	35V, 20%, RM5	0 R 2	57.11.3103	10k	MF	1%, 0207					
0 C 33	59.22.6100	10u	EL	35V, 20%, RM5	0 R 3	57.11.3104	100k	MF	1%, 0207					
0 C 34	59.06.0104	100n	PETP	63V, 10%, RM5	0 R 4	57.11.3102	1k0	MF	1%, 0207					
0 C 35	59.22.8229	2u2	EL	50V, 20%, RM5	0 R 5	57.11.3471	470R	MF	1%, 0207					
0 C 36	59.22.3221	220u	EL	10V, 20%, RM5	0 R 6	57.11.3104	100k	MF	1%, 0207					
0 C 37	59.22.8109	1u	EL	50V, 20%, RM5	0 R 7	57.11.3471	470R	MF	1%, 0207					
0 C 38	59.06.0104	100n	PETP	63V, 10%, RM5	0 R 8	57.11.3103	10k	MF	1%, 0207					
0 C 39	59.06.0104	100n	PETP	63V, 10%, RM5	0 R 9	57.11.3222	22k	MF	1%, 0207					
0 C 40	59.34.4101	100p	CER	63V, 5%, N750	0 R 10	57.11.3472	4k7	MF	1%, 0207					
0 C 41	59.34.4101	100p	CER	63V, 5%, N750	0 R 11	57.11.3000	0R0	MF	0207					
0 C 42	59.06.0104	100n	PETP	63V, 10%, RM5	0 R 12	57.11.3472	4k7	MF	1%, 0207					
0 C 43	59.06.0104	100n	PETP	63V, 10%, RM5	0 R 13	57.11.3151	150R	MF	1%, 0207					
0 C 44	59.06.0104	100n	PETP	63V, 10%, RM5	0 R 14	57.11.3153	15k	MF	1%, 0207					
0 C 45	59.22.6100	10u	EL	35V, 20%, RM5	0 R 15	57.11.3271	270R	MF	1%, 0207					
0 C 46	59.06.0104	100n	PETP	63V, 10%, RM5	0 R 16	57.11.3103	10k	MF	1%, 0207					
0 C 47	59.22.5220	22u	EL	25V, 20%, RM5	0 R 17	57.11.3103	10k	MF	1%, 0207					
0 C 48	59.22.5220	22u	EL	25V, 20%, RM5	0 R 18	57.11.3223	22k	MF	1%, 0207					
0 C 49	59.06.0154	150n	PETP	63V, 10%, RM5	0 R 19	57.11.3472	4k7	MF	1%, 0207					
0 C 50	59.22.6470	47u	EL	40V, 20%, RM5	0 R 20	57.11.3472	4k7	MF	1%, 0207					
0 C 51	59.22.5220	22u	EL	25V, 20%, RM5	0 R 21	57.11.3103	10k	MF	1%, 0207					
0 C 52	59.06.0104	100n	PETP	63V, 10%, RM5	0 R 22	57.11.3472	4k7	MF	1%, 0207					
0 C 53	59.34.4101	100p	CER	63V, 5%, N750	0 R 23	57.11.3223	22k	MF	1%, 0207					
0 C 54	59.06.0104	100n	PETP	63V, 10%, RM5	0 R 24	57.11.3153	15k	MF	1%, 0207					
0 C 55	59.34.4101	100p	CER	63V, 5%, N750	0 R 25	57.11.3223	22k	MF	1%, 0207					
0 C 56	59.06.0104	100n	PETP	63V, 10%, RM5	0 R 26	57.11.3223	22k	MF	1%, 0207					
0 C 57	59.06.0104	100n	PETP	63V, 10%, RM5	0 R 27	57.11.3133	13k	MF	1%, 0207					
0 C 58	59.34.1150	15p	CER	63V, 5%, NP 0	0 R 28	57.11.3103	10k	MF	1%, 0207					
0 C 59	59.34.1150	15p	CER	63V, 5%, NP 0	0 R 29	57.11.3223	22k	MF	1%, 0207					
0 C 60	59.22.3471	470u	EL	10V, 20%, RM5	0 R 30	57.11.3223	22k	MF	1%, 0207					
0 C 61	59.22.3471	470u	EL	10V, 20%, RM5	0 R 31	57.11.3133	13k	MF	1%, 0207					
0 C 62	59.22.6100	10u	EL	35V, 20%, RM5	0 R 32	57.11.3473	47k	MF	1%, 0207					
0 C 63	59.06.0104	100n	PETP	63V, 10%, RM5	0 R 33	57.11.3472	4k7	MF	1%, 0207					
0 C 64	59.06.0104	100n	PETP	63V, 10%, RM5	0 R 34	57.11.3133	13k	MF	1%, 0207					
0 D 1	50.04.0125	1N4448	75V	150mA, 4ns, DO-35	0 R 35	57.11.3133	13k	MF	1%, 0207					
0 D 2	50.04.0125	1N4448	75V	150mA, 4ns, DO-35	0 R 36	57.11.3103	10k	MF	1%, 0207					
0 D 3	50.04.0125	1N4448	75V	150mA, 4ns, DO-35	0 R 37	57.11.3103	10k	MF	1%, 0207					
0 D 4	50.04.0125	1N4448	75V	150mA, 4ns, DO-35	0 R 38	57.11.3103	10k	MF	1%, 0207					
0 D 5	50.04.0127	BAT85	200mA	Schottky	0 R 39	57.11.3103	10k	MF	1%, 0207					
0 D 6	50.04.0519	1N5822	3A	Schottky	0 R 40	57.11.3103	10k	MF	1%, 0207					
0 D 7	50.04.1112	5V1	Zener	5%, 0.5W, DO-35	0 R 41	57.11.3103	10k	MF	1%, 0207					
0 IC 1	50.10.0104	LM317SP	IC	LM 317 SP, T.	0 R 42	57.11.3101	100R	MF	1%, 0207					
0 IC 2	50.15.0127	34C87	IC	DS 34 C 87 TN, MC34C87P, A	0 R 43	57.11.3103	10k	MF	1%, 0207					
0 IC 3	50.15.0128	34C86	IC	DS 34 C 86 TN, MC34C86P, A	0 R 44	57.11.3103	10k	MF	1%, 0207					
0 IC 4	50.17.1086	74HC86	IC	... 74 HC 86 ... A	0 R 45	57.11.3472	4k7	MF	1%, 0207					
0 IC 5	50.10.0118	L4962	IC	L 4962 E.	0 R 46	57.11.3103	10k	MF	1%, 0207					
0 IC 6	50.11.1901	TDA1074	IC	TDA 1074A.	0 R 47	57.11.3471	470R	MF	1%, 0207	</				

## 9 APPENDIX

---

### 9.1 Serial Remote Protocol

---

#### 9.1.1 RS422 9-pin Protocol (Sony-Compatible)

---

The following remote control specification for the D424 is intended for applications where basic functions compatible with the “Sony 9-pin standard” are required. It provides a subset of the complete D424 functionality.

In addition to the standard commands, an extension was made to allow addressing of takes and indices instead of timecode and tape counter parameters only.

#### 9.1.2 Communication Format

---

Communication between a controlling device (controller) and the D424 is established by following these rules:

All communication is initiated by the controller sending a command message. The D424 will respond with a message containing the requested data or an acknowledgement.

- The D424 responds within 9 ms after having received the last byte.
- The interval between two command bytes within a message should not exceed 10 ms.
- If no data were requested, the D424 simply gives an ACK (acknowledged) reply message.
- A data reply message is sent after receiving a data request command.
- If a transmission error is detected, or if an unknown command is received, the D424 will respond with a “not acknowledged” message (NAK + ERROR DATA)
- If a NAK command (indicating a transmission error) is received during sending a message, the command transmission should be resumed after a pause of 10 ms.
- If no response is detected within 10 ms after sending a complete command message, the communication is considered to be faulty.
- The controller should not send new messages before having received a response from the D424.

9.1.3 Hardware Layer

- EIA RS422A
- Data rate 38.4 kBaud
- Full duplex communication
- Bit-serial asynchronous data transmission
- Data format:  
 1 start bit (logic “0” = SPACE)  
 8 data bits  
 1 parity bit (odd, number of “1” in D0...D7 and parity is odd)  
 1 stop bit (logic “1” = MARK)

LSB								MSB		
start bit	D0	D1	D2	D3	D4	D5	D6	D7	parity	stop bit

**Connector:** D-type, 9 pin female

D424	Pin	Controlling device
Frame ground	1	Frame ground
Transmit A	2	Receive A
Receive B	3	Transmit B
Receive common	4	Transmit common
+24 V	5	-
Transmit common	6	Receive common
Transmit B	7	Receive B
Receive A	8	Transmit A
Frame ground	9	Frame ground
Logic "0" (SPACE) if signal B < A, logic "1" (MARK) if signal B > A		

9.1.4 Messages

The structure of a command or a response message is as follows:

Byte 1	Byte 2	Byte 3	...	Byte n+2	Byte n+3
CMD1	N	CMD2	DATA 1	...	DATA n
					CHKS

**Byte 1 Command byte 1 (CMD 1)**

The upper 4 bits of byte 1 indicate the command group and the communication direction.

*From controller to D424:*

- 0: System control command
- 2: Transport command
- 4: Preset/select command
- 6: Data request

*From D424 to controller:*

- 1: System control response (for type 0/2/4 commands)
- 7: Data response

**Data count (N)**

The lower 4 bits of byte 1 is the number of data bytes between CMD 2 and CHKS (0...15).

**Byte 2 Command byte 2 (CMD 2)**

The second command byte specifies a particular command (see command list)

**Byte 3... Data bytes (DATA 1...DATA n)**

Up to 15 data bytes may be added to a command, indicated by the data count in byte 1.

**Byte n+3 Checksum byte (CHKS)**

The checksum byte is calculated by summing up all bytes before the checksum byte (max. 17 bytes) and taking the least significant byte of the result.

## 9.1.5 Command List

	Command from controller			Comment	Response D424		
	CMD 1/2		Data		CMD 1/2		Data
				NAK response	11	12	error
STOP	20	00	--		10	01	--
PLAY	20	01	--		10	01	--
RECORD	20	02	--		10	01	--
FFWD	20	10	--	shuttle at max. speed	10	01	--
REW	20	20	--	shuttle at max. speed	10	01	--
SHTL FWD	21	13	speed		10	01	--
SHTL REW	21	23	speed		10	01	--
CUE UP WITH DATA	24	31	time	locate	10	01	--
CHASE	21	37	00	timecode chase	10	01	--
SELECT EE ON	20	63	--	select input	10	01	--
EDIT ON	20	64	--	record punch-in	10	01	--
EDIT OFF	20	65	--	record punch-out	10	01	--
EDIT PRESET	41	30	emode	rec mode & channels	10	01	--
TIMER MODE SELECT	41	36	tmode	set timer mode	10	01	--
CHASE OFFSET PRESET	41	78	time	set chase offset	10	01	--
TIMER MODE SENSE	60	36	--	read current timer position	71	36	tmode
CURRENT TIME SENSE	61	0C	tsource	read current position	74	0x	time
STATUS SENSE	61	20	status address	read current status	7x	20	status

**Formats:**

**speed** 1-byte speed format, with speed =  $10^{(N/32-2)}$ ; e.g.:

data (hex)	0	20	2A	36	40	46	4A
speed	0	0.1	0.2	0.5	1.0	1.5	2.0

**time** Time parameter according to selected timer mode or requested format. 4 bytes, BCD coded (byte 1 = LSB ... byte 4 = MSB):

data 1		data 2		data 3		data 4	
frame 10	frame 1	sec 10	sec 1	min 10	min 1	hour 10	hour 1

Timecode or absolute time: frames, seconds, minutes, hours.

Timer 2 (track, indices): index, track, don't care, don't care.

**emode** Recording mode and channel ready select (see EDIT PRESET).

**tmode** Timer mode: TC, absolute or track/index (see TIMER MODE SELECT).

**tsource** Time source: TC, absolute or track/index (see CURRENT TIME SENSE).

**error** Error type, returned with NAK message.

bit 7					bit 0		
timeout	framing	overrun	parity	-	check-sum	-	undefined command



9.1.6 Command Messages

<b>STOP</b>	STOP command
<b>PLAY</b>	PLAY command
<b>RECORD</b>	REC command, corresponds to <b>[PLAY+REC]</b> key combination
<b>FFWD</b>	Fast forward, corresponds to shuttle forward with pre-selected speed ( <b>[PLAY+NEXT]</b> )
<b>REW</b>	Fast rewind, corresponds to shuttle reverse with pre-selected speed ( <b>[PLAY+PREV]</b> )
<b>SHTL FWD</b>	SHUTTLE FORWARD command
<b>SHTL REV</b>	SHUTTLE REVERSE command
<b>CUE UP WITH DATA</b>	LOC command, parameter format is pre-selected with <b>TIMER MODE SELECT</b>
<b>CHASE</b>	CHASE command
<b>SELECT EE ON</b>	All channels that were set to <b>READY</b> with an <b>EDIT PRESET</b> command will be switched to input. A subsequent <b>EDIT OFF</b> will switch them back.
<b>EDIT ON</b>	Corresponds to a <b>RECORD</b> punch-in command ( <b>[REC+PLAY]</b> )
<b>EDIT OFF</b>	Corresponds to a <b>RECORD</b> punch-out command ( <b>[PLAY]</b> )
<b>EDIT PRESET</b>	Presets the recording mode and the channel <b>READY</b> status.

bit 7	bit 0
-	insert   assemble   -   -   TC   A2   A1

insert, assemble: correspond to D424 recording mode  
 TC, A2, A1: are the D424 recording channels

**TIMER MODE SELECT**    For setting and reading the timer mode. The selected format is used for  
**TIMER MODE SENSE**    the **CUE UP** command and other time position-related commands.

timer mode:    0: timecode  
                   1: timer 1 (absolute time)  
                   2: timer 2 (track, markers)

**CHASE OFFSET PRESET**    Sets the nominal chase offset. Negative offsets can be defined with parameters >12 hours.

**CURRENT TIME SENSE**    The position may be reported as timecode value, either as absolute time, or in tracks-and-marker notation.

	Controller command	Device response
timecode	61 0C 01	74 04 time
timer 1 (abs.)	61 0C 04	74 00 time
timer 2 (tracks)	61 0C 08	74 01 time

**STATUS SENSE** The device status is listed in an 8-byte field, each bit representing a status information. A status sense command requests a number of bytes from the field, starting at a specified offset.

Controller command: 61 20 xy

Device response: 7n 20 xy data i...data j

x (bit 4...7): First byte to report

y (bit 0...3): Number of bytes to be reported

Data	Bit							
	7	6	5	4	3	2	1	0
0			no disk					local
1	standby		stop		rew	ff	rec	play
2	locked		shtl		var	dir	still	cued up
3								
4	sel EE			edit				cueing up
5	insert	assmbl					A2	A1
6								
7				chase				

- no disk** “1” when disk is fully ejected
- local** “1” when D424 is operated locally
- standby** Set when D424 enters standby on mode
- stop** Set when D424 enters stop mode
- rew** Set when D424 enters rewind mode
- ff** Set when D424 enters fast forward mode
- rec** Set when D424 enters recording mode (ass/ins)
- play** Set when D424 enters play mode
- locked** “1” when D424 is correctly locked to sync source
- shtl** Set when D424 enters shuttle mode
- var** Set when D424 enters varispeed play mode
- dir** Transport direction, “0” = forward, “1” = reverse. During STOP or STILL mode the direction before D424 stopped is indicated.
- still** Is set in shuttle mode when the speed is 0.
- cued up** Is set when a CUE UP command has been completed and reset when the position is changed again.
- sel EE** Is set when one or more channel is switched to input (with EDIT PRESET and SELECT EE ON).
- edit** Is set when the D424 enters an assemble or insert recording mode with the EDIT ON command.
- cueing up** “1” during CUE UP mode
- insert** “1” when recording mode is set to INSERT
- assmbl** “1” when recording mode is set to ASSEMBLE
- A2** “1” when channel 2 is set to READY
- A1** “1” when channel 1 is set to READY
- chase** Is set during chase mode

## 9.2 Drive Installation Instructions

### 9.2.1 MO Drive Kit 2.6 GB (ISO)

#### 9.2.1.1 Settings

The following settings at the functional switch have to be checked at the rear of the drive:

Jumper 3 inserted (SCSI address 1; refer to section 5.2)

Jumper 7 inserted (force verify after write)

Jumper 11 inserted (termination on)

#### 9.2.1.2 Installation

1. Disconnect the unit from the mains supply and remove the cover.
2. Disconnect the power cable and the SCSI ribbon cable on the rear side of the currently installed drive.
3. Remove the old drive by removing the fixing screws (2 at each side).  
On units with serial number below "1001" that were shipped with the 2.2 GB Pioneer drive, the two drive mounting brackets have to be replaced. The new brackets are part of the upgrade kit and allow the installation of a wide variety of drives.
4. The new ISO drive is mounted from the front of the D424, by sliding it through the front panel opening and attaching it with the 4 corresponding screws at the brackets.
5. Reconnect both power supply and SCSI ribbon cables to the ISO drive and reinstall the cover.

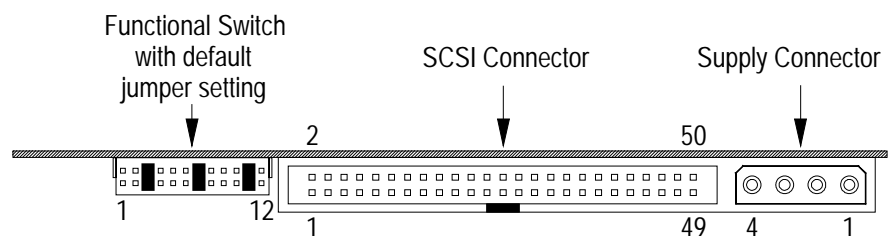

#### 9.2.1.3 Accessories

The 2.6 GB ISO drive is capable of recording to and playback from the following ISO compatible disks (all disks available on request):

<b>1.2 GB</b>	512 bytes/sector
<b>1.3 GB</b>	1024 bytes/sector
<b>2.3 GB</b>	512 bytes/sector
<b>2.6 GB</b>	1024 bytes/sector

## 9.2.2 MO Drive Kit 5.2 GB (ISO)

### 9.2.2.1 Settings

The following settings at the functional switch have to be checked at the rear of the drive:

- Jumper 3 inserted (SCSI address 1; refer to section 5.2)
- Jumper 5 inserted (disable write cache)
- Jumper 7 inserted (force verify after write)
- Jumper 11 inserted (termination on)

### 9.2.2.2 Installation

1. Disconnect the unit from the mains supply and remove the cover.
2. Disconnect the power cable and the SCSI ribbon cable from the rear side of the currently installed drive.
3. The new ISO drive is mounted from the front of the D424, by sliding it through the front panel opening and attaching it with the 4 corresponding screws at the brackets.
4. Reconnect both power supply and SCSI ribbon cables to the ISO drive and reinstall the cover.

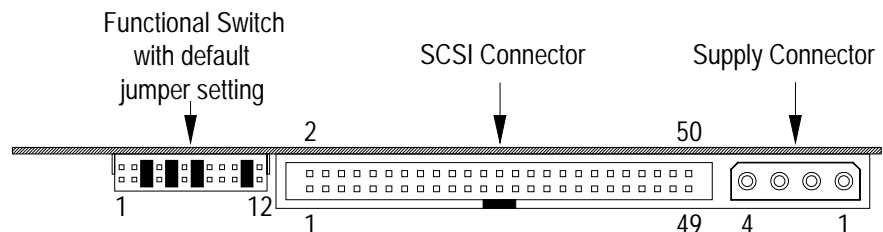

### 9.2.2.3 Accessories

The 5.2 GB ISO drive is capable of recording to and playback from the following ISO compatible disks (all disks available on request):

<b>2.3 GB</b>	512 bytes/sector
<b>2.6 GB</b>	1024 bytes/sector
<b>4.1 GB</b>	512 bytes/sector
<b>4.8 GB</b>	1024 bytes/sector
<b>5.2 GB</b>	2048 bytes/sector (D424 uses one 2 GB partition per side)

### 9.3 Hardware Configuration (Jumper and DIP Switch Settings)

#### 9.3.1 Motherboard

<b>1. Supply voltage on the parallel remote connector (pin11):</b>		
24 V / max. 300 mA, if JP1 and JP 2 are linked; 5 V / max. 700 mA, if JP2 and JP3 are linked.		
<b>2. Supply voltage on the Serial remote connector (pin9):</b>		
24 V if JP4 and JP5 are linked n.c. if JP5 and JP6 are linked		
<b>3. DIP switch (DS1)</b>		
1	OFF	Spare
2	OFF	Spare
3	OFF	Spare
4	ON	Baud rate (off position used for factory tests only)

#### 9.3.2 Core

The address for the Desktop Controller is normally set in the Setup menu. On units without a front panel operating surface this has to be done with DS1 (on from SW version 1.2).

The controller interface can be selected for operation with the Studer Desktop Controller or with a customer-specific remote control; for this purpose DIP switch No. 1 of DS1 is provided.

<b>DS1:</b>				
1	2	3	4	
<b>Controller port operation mode:</b>				
OFF	x	x	x	Operation w. Studer controller/31.25 kBaud
ON	x	x	x	Operation w. spec. controller/38.4 kBaud
<b>Controller address:</b>				
x	x	OFF	OFF	Selectable on front panel
x	x	OFF	ON	Address 1
x	x	ON	OFF	Address 2
x	x	ON	ON	Address 3

J401 and J403 are always inserted.

All remaining jumpers remain open. They are used for matching to the DP RAM size (J405 and J407), as programming connectors for IC 601/701 (P601...P610 and P701...P710), as a Debug connector for the DSP (IC302) (P301...310) and the processor (IC102) (P111...120), or as a monitoring interface (P101...P103).