



**REVOX**

**Service  
Manual**

**D36**

**E36**

**F36**

## CONTENTS

	Page
1. GENERAL	1
2. MECHANICAL DESCRIPTION	1
2.1. Mechanical checks and adjustments	2
2.1.1. Tape path	2
2.1.2. Brakes	3
2.1.3. Tape tension	3
2.1.4. Pinch roller	3
2.1.5. End of tape switch	4
2.1.6. Wow and flutter	4
2.1.7. Tape speed	4
2.2. Routine maintenance	4
2.2.1. Cleaning	4
2.2.2. Lubrication	5
2.2.3. Servicing of solenoids	5
2.2.4. Servicing of push button assembly	5
2.3. Removal of capstan assembly	5
3. ELECTRONIC DESCRIPTION	6
3.1. Circuit checks and adjustments	6
3.1.1. Measuring instruments	6
3.1.2. De-magnetising	7
3.1.3. Head alignment	7
3.1.4. Playback amplifier	8
3.1.5. Bias adjustment	8
3.1.6. Measurement of record/playback response	8
3.1.7. Adjustment of level control	9
3.1.8. Adjustment of head shielding	9
4. TROUBLESHOOTING	10
4.1. Mechanical troubleshooting	10
4.2. Electronic troubleshooting	12

### APPENDIX

Fig. 2 - Fig. 9

Tables Play-back equalization / Recording pre-emphasis

Schematic Diagrams Models D 36, E 36, F 36

## 1. GENERAL

The REVOX Series 36 has been constantly improved and kept up to date, since it was first introduced in 1956. However, the present F still bears the same basic layout and conception as did the original A model.

With the advance of stereophonic recording it was necessary to enlarge the electronics of the recorder to provide twin record and replay pre-amplifiers. This was first put into production with the D series and the E and F have only minor modifications and additions to the original design.

Also with the introduction of the D, both 2 and 4 track versions of the recorder were made available. Identification was made by the appropriate number being stamped on the head mounting plate, and on the upper side of the lower chassis.

The recorder consists of an upper and lower chassis. These are joined at the rear by means of the back panel which carries the input and output sockets, mains voltage adjuster and fuseholder, and at the front by means of the loudspeaker panel mountings. The upper chassis carries the tape transport mechanism and the lower chassis bears the power supply unit and the electronics.

## 2. MECHANICAL DESCRIPTION

The machine employs three motors. Two are identical and perform the wind and tension functions, as well as providing a bearing and spindle for the spool carriers. The third motor is large and drives the capstan. It is of the pole switching variety and speed change is therefore effected electrically.

The wind motors are designed to provide pulse free torque. Back tension is applied during the record and playback functions but not during wind.

The capstan assembly consists of the motor, and the capstan onto which is bolted the flywheel. The coupling between the motor and the flywheel consists of a special rubber disc which is designed to damp any motor flutter present.

The pinch roller is held against the capstan during record and replay functions with considerable pressure. This necessitates the use of a capstan bearing designed specifically to withstand considerable side pressure for long periods. Further, to ensure that the axes of the pinch roller and the capstan run parallel, the pinch roller arm bearing is cast integral with that of the capstan. The pinch roller is linked to a heavy duty solenoid and this is controlled by the appropriate push button.

The brakes are mechanical in nature but are electrically operated. This

is achieved by the action of the brake solenoid which pulls the brakes off during all operating functions. When the stop button is pressed however, or when the current fails for any reason, the solenoid is de-energised, and the brakes automatically come on.

All functions are controlled by the push buttons.

Arcing damage and noise is prevented by the use of diodes and RC networks. A sensing lever on the LH tape guide operates a micro-switch which, in series with the stop button, provides a current path to a solenoid incorporated in the push button unit. This has the effect of clearing any selected function either by depressing the stop button or operation of the end of tape switch. A three digit tape counter is driven from the take-up turntable by a rubber belt. The translucent resetting knob of the counter is lit by a small pilot bulb which acts as a mains indicator.

A remote control facility is provided. Removal of the shorting link from the socket on the rear panel and the insertion of the correct accessory plug, lead and switch, enables the recorder to be started or stopped in either the record or playback function as selected. Operation of the remote control switch has the effect of de-energising both the capstan and brake solenoids, whilst the push button solenoid is out of circuit, when the remote control is in use.

## 2.1. Mechanical checks and adjustments

It is advisable to use a full and an empty 25 cm spool when carrying out adjustments. Whilst the majority of tape transport checks are being made, it is essential to keep the plastic top cover in position. For other mechanical adjustments the top and head covers should be removed.

### 2.1.1. Tape path

The tape path level is determined by the left and right hand tape guides and by a small guide positioned between the playback head and the capstan. We do not recommend that these guides should be interfered with in any way. Adjustment to the spool carrier height can of course be made to enable the tape to be wound centrally between the spool flanges. This is brought about by adjusting the grub screw of the spool carrier and sliding the carrier up or down on its spindle. Care should be taken to prevent damage to the brake bands at this stage. Where a spool carrier has to be removed, it is recommended that the brake band be removed first.

### 2.1.2. Brakes

The layout of the brake system is shown in fig. 3 ( appendix ). It is important to note that the ends of the brake band and their respective mounting brackets remain parallel to each other and adjustment of this can be made by bending tail 6.

This is especially important when fitting spool carriers using thinner brake linings, which will also necessitate increasing spring tension by bending lug 23. When correctly adjusted the distance from 7 to the operating lever 8 will be 2 mm. Finally it is important to check that the brake band is running flat on the brake lining and not biting on the upper or lower edge.

Correct tension for spring 10 is obtained when a 160-220 grams applied as a tangent force to a 10 cm diam ( spool and tape ), causes the spool to move. See fig. 4 ( appendix ).

### 2.1.3. Tape tension

Back tension is applied by the combination of reverse direction torque from the feed motor and the positioning of the guide pin. Threading the measurement gauge outlined in fig. 4 ( appendix ), on to the machine in the normal manner, having removed the head cover the playback and stop button should be depressed simultaneously and the pinch roller permitted to come within 5 mm of the capstan. Drawing the tape through the tape path should require a pressure of about 70 grams. As a double check a full 25 cm spool should be employed and a reading of about 30 grams should be obtained. Should a greater differing reading be obtained the following items should be checked :

- a. Adjustment of the brake band
- b. Value of resistor across feed motor ( 2,2 k $\Omega$  )
- c. Electrical fault in feed motor
- d. Electrical fault in phase shift-condenser ( C 72, pos. 22 in fig. 6 )

### 2.1.4. Pinch roller

The pressure of the pinch roller can be measured by a gauge fixed to the pinch roller arm as close as possible to the spindle of the pinch roller ( fig. 5 appendix ). A constant tone tape should be played and the pinch roller withdrawn by the gauge until the note is heard to change. A reading in the region of 1,5 kg should be obtained. Adjustment to this value can usually be obtained by turning nut 23. Should this not provide the necessary amount of correction it is probable that some mechanical displacement has taken place and it is advisable to check the position of the solenoid 24 which will be correct when there is about

1/2 to 1 mm clearance at point 13 when the solenoid is de-energised.

#### 2.1.5. End of tape switch

This switch and its associate operating levers must be thoroughly clean to function correctly. The right position for the switch assembly is essential for correct operation to be obtained. This positioning is carried out by slackening the fixing screws and moving the switch bodily.

#### 2.1.6. Wow and flutter

Accurate and useful measurement of wow and flutter can only be made with an appropriate instrument. The recorder is calibrated using the EMT Model 420. Possible causes of flutter may well lie with the capstan, capstan motor or the flexible coupling. Wow can usually be seen as associated with the pinch roller speed and in some cases a faulty pinch roller may be the cause, and in others too much back tension or insufficient pinch roller pressure. For all wow and flutter investigations the transport mechanism must be completely clean.

#### 2.1.7. Tape speed

Tape speeds can be checked by running a marked, measured length of tape through the recorder. For a 100 sec. run 950 cm would be required at 3 3/4 ips and 1905 cm at 7 1/2 ips. The difference in running time in seconds will be the speed variance as a percentage. Some variance can be expected with temperature increase but this should lie within the quoted tolerance. In very cold weather it may be noted that the recorder runs accurately at 3 3/4 ips but slows down when switched to 7 1/2 ips. This is due to drag from the cold grease in the capstan bearing, especially when new. After a short time of operation at 3 3/4 ips the machine should be capable of running at 7 1/2 ips.

### 2.2. Routine maintenance

#### 2.2.1. Cleaning

From time to time the working parts of the recorder which come in contact with the tape should be thoroughly cleaned with methylated spirits. Cleaning of the head faces is particularly important, espe-

cially in the case of four track heads where seemingly invisible particules can often have an adverse effect on performance.

#### 2.2.2. Lubrication

The use of three motors reduces the need for lubrication to only a few points. Regular lubrication of the wind motors is not anticipated. However should the need be felt to lubricate these motors, they should be dismantled, the inner felt lining oiled and the ball race replaced. Externally the rotor of capstan motor rides on a ball bearing. This may be greased with a molybdenum coumpound. If further lubrication is necessary, the motor should be dismantled and the felt rings at each bearing should be oiled. In all cases with the Papst motors employed ESSO TERRESSO 43 oil should be used. The capstan bearing is factory packed with grease and it is envisaged that this will have a possible life of several thousand hours, which should correspond to the usefull life of the capstan itself.

#### 2.2.3. Servicing of solenoids

When it appears that a solenoid is tending to stick or function erratically, it should be dismantled and the slug and housing thoroughly cleaned with methylated spirits. When both parts are properly clean and dry, molybdenum grease may be rubbed into the working surfaces which must finally be wiped dry before re-assembly.

#### 2.2.4. Servicing of push button assembly

Conventional switch cleaners are not recommended for the high current spring contacts used in the REVOX, and where cleaning is necessary the contacts should be polished clean. The interlocking bars and push-button shafts may require occasional greasing. Where a part of the assembly needs replacement, it may be easier to unscrew the four fixing screws, bend the push-buttons to the right and ease the unit to a better working position.

#### 2.3. Removal of capstan assembly

This may become necessary where the recorder is to be used on a mains frequency which differs from that for which the recorder was manufactured, or when a replacement capstan assembly becomes necessary.

Having removed the chassis from the cabinet and the loudspeaker and panel, separate upper and lower chassis sections by undoing screws

no 18 in fig. 2 ( appendix ). The pinch roller arm may now be removed by loosening screws no 21 in fig. 7 ( appendix ). After the capstan mounting screws no 19 in fig. 2 have been removed the assembly may be taken downwards and forwards out of the chassis. The motor fixing screws no 20 in fig. 7 should now be removed and with them the flexible coupling. To remount the assembly the reverse procedure should be adopted and particular attention paid to the position of the pinch roller arm when tightening grub screws 21 in fig. 7. With the linkage and solenoid in the de-energised position the screws 21 should be tightened when the pinch roller arm is parallel to the front chassis edge. The pinch roller pressure should now be checked as in 2.1.4. and adjusted if necessary as outlined therein. Where a change of mains frequency is involved it will also be necessary to change the motor condensers numbered 22 in fig. 6 ( appendix ).

### 3. ELECTRONIC DESCRIPTION

Access to the majority of the electronics of the recorder can be obtained by removing the base of the recorder.

It should be borne in mind that changes in characteristic and equalisation have been made during the production of the 36 series. It is essential therefore that measurements and calibration tapes should be those intended for the particular model under examination.

#### 3.1. Circuit checks and adjustments

##### 3.1.1. Measuring instruments

The following items are essential :

- a. 10,000  $\Omega$ /V DC Multirange meter
- b. VTVM with min. sensitivity of 3 mV full scale
- c. Low distortion audio generator
- d. Appropriate calibration tape

It will be found useful to employ a double beam oscilloscope for rapid and accurate azimuth alignment. Other desirable but not essential instruments include a distortion factor meter and a milli volt meter with a sensitivity of 1 mV f/s.

Direct record and replay figures can only be taken when a suitable bias filter is in circuit.



### 3.1.2. De-magnetising

From time to time the ferrous parts in contact with the tape may become magnetised. When this occurs, and especially with head magnetisation, an increase in background noise will be evident and in serious instances, partial erasure of the tape may come about. De-magnetisation should be carried out with the appropriate instrument at frequent intervals and care should be taken at all times to ensure that magnetised tools do not come in contact with the head assembly.

### 3.1.3. Head alignment

Head adjustment should only be necessary when a head requires replacement or where the setting has been interfered with. Five adjustment screws are provided. The centre screw no 17 in fig. 9 ( appendix ) photograph must be undone to remove the head or to adjust the head around the vertical axis. Adjust screw no 15 at the rear of the head for height, which will be correct when the upper brass spacer of the heads is divided by the upper tape edge. Front screw no 15 should then adjusted to bring the head face vertical with the tape. N.B. The adjustment outlined above is usually correct but manufacturing tolerances can effect the final positioning. Where the above has been carried out and is not satisfactory, reference should be made to our service department. Where a 4-track recorder is under examination, it may be advisable to obtain the 4-track alignment tape produced by the factory. Relevant instructions are included with the tape. Azimuth adjustment must be carried out by turning screw no 16. The playback head must always be adjusted first, and an alignment tape should be used for this purpose. With the output coupled to a VTVM, screw 16 should be adjusted to give maximum output from tape. Where a double beam oscilloscope is available this should be employed so that traces from both channels can be observed simultaneously. Accurate azimuth alignment will permit phase to be maintained between channels at all frequencies. For this purpose an alignment signal of 12 kc/s will be found suitable and when correctly aligned a change of frequency will not affect the locking of phase between channels.

To adjust the record head ensure that the playback head is correct. Using the playback channel as a measuring reference, a signal of 12 kc/s should be recorded and the record head adjusted to give maximum playback output. Again the phase check method may be employed and this will have the effect of phasing the machine from input to output via tape at all frequencies.

#### 3.1.4. Playback amplifier

Before any tests are made, on the playback section of the recorder it is essential to ensure that the playback head is scrupulously clean. Connect a VTVM to the cathode follower output of each channel in turn. A reference signal recorded at 32 mM per one mm tape width should give an output of approximately 350 mV on a 2-track recorder and 250 mV in the case of a 4-track machine. The frequency response section of the calibration tape is normally recorded about 20 db below this level, and for these measurements a milli voltmeter will almost certainly be essential. A response of +2 -3 db referred to 1 kc/s is acceptable. Where unsatisfactory figures are obtained it is advisable to replace the playback head as outlined in 3.1.3. and take new readings. Should this not bring about the desired improvement, the playback pre-amplifier should be examined. Remove the earth connection of the playback head and insert a 10  $\Omega$  resistor in series. Connect an audio generator across the resistor and adjust output at 1 kc/s to give 70 mV at the cathode follower. The results obtained with the use of the generator should coincide with the figures shown in the table "Playback equalization" ( appendix ).

Where a considerable deviance exists checks should be made on the voltage values obtained within the circuit with special regard to the negative feedback loop which is frequency conscious.

#### 3.1.5. Bias adjustment

If a low pass filter is available, it is recommended that this be used in the circuit to reduce the amount of bias leakage. With the filter in use it is possible to adjust the bias whilst observing the effect on a VTVM at the cathode follower output. If there is no filter available it will be necessary to make separate record and playback checks. The recommended procedure is to employ a long playing tape of compatible quality and to record a 1 kc/s signal at 3 3/4 ips. The bias should be adjusted for maximum tape sensitivity and the input level adjusted to give an output of approximately 350 mV. The generator output should be reduced by 15 db and the level noted, the frequency should then, be changed to 12 kc/s, and the bias adjusted to an output identical to that at 1 kc/s. On model E 36 adjustment of bias is made with condensers C 44, C 49, whilst on model F 36 P 10 and P 11 should be used.

#### 3.1.6. Measurement of record / playback response

Before any attempt is made to verify the overall response figures, it is advisable to see that all items 3.1.2., 3.1.3., 3.1.4. and 3.1.5. have been properly observed. Direct record - playback figures can be taken when a bias filter is available, otherwise separate record and playback runs will have to be made. A 1 kc/s signal should be

recorded at maximum recording level, via the radio input socket. The level of the signal should then be attenuated by 20 db and the response curves taken. The results should lie within the tolerances quoted in the specification. Where a deviation is observed it can be assumed to be in the record section of the machine, provided that the checks outlined in 3.1.4. and 3.1.5. have been correctly executed. If a fault is suspected to lie in the record section of the recorder, the record head should first be changed. If this does not prove to be the cause of the trouble, the response curves of the amplifier should be checked with the bias oscillator valve removed. Head-current versus frequency response characteristics for the models D, E and F-36 and their various speed combinations are shown in the table "Recording Preemphasis" ( appendix ). Any variance in the response curves will almost certainly lie in a component failure or valve change, and appropriate investigation should be made.

#### 3.1.7. Adjustment of level control

The setting of the recording level indicator should be made with the assistance of either a distortion factor meter or a reference level tape, known to be 32 mM/mm. With the distortion factor meter the 1 kc/s signal to the recorder should be increased until the meter registers 3% distortion at the cathode follower output. The magic eye trimmer should then be set to cause the eye to just close. When a calibration tape is employed, a reference level of 32 mM/mm will give an output which should be noted on a VTVM at the cathode follower output. A signal generator should now be employed and the level of the 1 kc/s tone should be increased to 5 db beyond the reference figure given by the tape. The magic eye trimmer should now be adjusted so that the eye is just closed.

#### 3.1.8. Adjustment of head shielding

This may sometimes be necessary in order to keep the operating hum levels at a minimum. It should be noted also that since hum can be picked up by the electronics on the underside of the recorder, care must be taken to screen the base when the chassis is removed from its case, whether on the service bench for attention, or when built into a cabinet.

To adjust the playback head shield, place two spools on the recorder with a half reel of tape wound on each and without threading the tape depress the play and stop buttons. The tape should remain stationary and the head shield may be adjusted to give the lowest reading on a milli voltmeter connected to the cathode follower output. If two meters are available it is advisable to check both channels simultaneously since an improvement in one may bring about a deterioration in the other.

## 4. TROUBLESHOOTING

### 4.1. Mechanical troubleshooting

Trouble	Cause	How to repair
Capstan motor does not run at either speed	Speed switch defective	Replace wafer
	Jamming motor	Clean and lubricate bearings ( 2.2.2.)
	Jamming capstan bearing	Replace capstan assembly
Noisy capstan	vibrating bearing-bracket	Bearing-bracket must be free of mechanical tension and should be adjusted so that the tapped holes in the bracket align perfectly with the holes of the motor-mounting plate
	felt of the lower bearing damaged	Replace felt and lubricate with JAE 20 oil
	loose flywheel	Tighten fastening nut
	capstan coupling arm touches the flywheel	Lower the capstan coupling arm
	Damaged capstan-bearing	Replace capstan assembly
Tape speed too low	open-circuit motor-winding	Replace capstan motor
	faulty motor condenser	Replace motor condenser
	Jamming motor	Clean and lubricate bearings ( 2.2.2.)
	jamming capstan	Replace capstan assembly
Capstan runs at 3 3/4 but not at 7 1/2 ips.	recorder too cold and drag from new bearing or grease too great	Run at 3 3/4 for a few minutes. Recorder will then pick up to 7 1/2 ips.

Trouble	Cause	How to repair
Pinch roller arm does not operate	Dirty solenoid	Clean and adjust solenoid ( 2.2.3.)
	Dirty contacts in the push-button assembly	Clean and adjust contacts ( 2.2.4.)
	Dummyplug of remote control removed	Connect pin 1, 2 and 3 of the remote control socket
Brakes do not release	Dirty brake-solenoid	Clean and adjust solenoid ( 2.2.3.)
	Dirty contacts in the push-button assembly	Clean and adjust contacts ( 2.2.4.)
	Dummy plug removed	Connect pin 1, 2 and 3 of the remote control socket
Push-button will not remain in pressed position	End of tape switch does not operate	Adjust ( 2.1.5.)
	Incorrectly threaded tape	Thread the tape as explained in the instruction manual
End of tape switch does not operate	Dirty solenoid	Clean and adjust ( 2.2.3.)
	End of tape switch contacts maladjusted	Adjust ( 2.1.5.)
	Left hand tape guide dirty	Clean ( 2.2.1.)
Wow and flutter	Damaged or dirty pinch roller, pinch roller pressure insufficient, damaged plastic coupling, damaged flywheel bearing left side brake maladjusted, jammed turntable motor	Replace pinch roller. Clean capstan and pinch roller, adjust pinch roller arm ( 2.1.4.) Replace coupling Replace capstan assembly, adjust brake ( 2.1.2.) clean and lubricate motor-bearings

Trouble	Cause	How to repair
Fast rewind or forward too slow	Brake maladjusted	Adjust brakes ( 2.1.2.)
	Dirty brake solenoid	Clean solenoid ( 2.2.3.)
	Open-circuit winding in the Turntable-motor	Replace turntable-motor
	Defective motor-condenser	Replace motor-condenser

#### 4.2. Electronic troubleshooting

Trouble	Cause	How to repair
Playback hum	Disconnection in the playback head	Replace playback head
	Front shielding of the playback head out of adjustment	Adjust front shielding ( 3.1.8.)
Playback hiss	Faulty tube in the playback amplifier	Replace tube
	Magnetised playback head	De-magnetising the head ( 3.1.2.)
Bad treble response	Dirty head	Clean the heads ( 2.2.1.)
	Heads out of alignment	Adjust the heads ( 3.1.3.)
	Worn out heads	Replace heads
	Tape wrongly threaded	Thread tape as explained in the instruction manual
	Bias incorrect	Adjust bias ( 3.1.6.)
Absence of recording or insufficient recording	Dirty recording-head	Clean the head
	Defective recording-head	Replace the head
	Dirty contact of recording push-button	Clean and adjust contact

Trouble	Cause	How to repair
	Incorrect bias adjustment	Adjust bias ( 3.1.6.)
	Defective bias-oscillator	Check bias-oscillator tube, coil and erase head
Insufficient erasure	Erase head soiled	Clean heads ( 2.2.1.)
	Erase head defective	Replace erase head
	Bias-oscillator defective	Check bias-oscillator tube, coil and erase head
No indication at the magic eye	Magic eye defective	Replace magic eye
	Indicator amplifier valve defective	Replace valve
	Diode defective	Replace diode
	Maladjusted potentiometer	Adjust level control ( 3.1.7.)
Short circuit in the power supply	Speed switch of capstan-motor burned out	Replace wafer

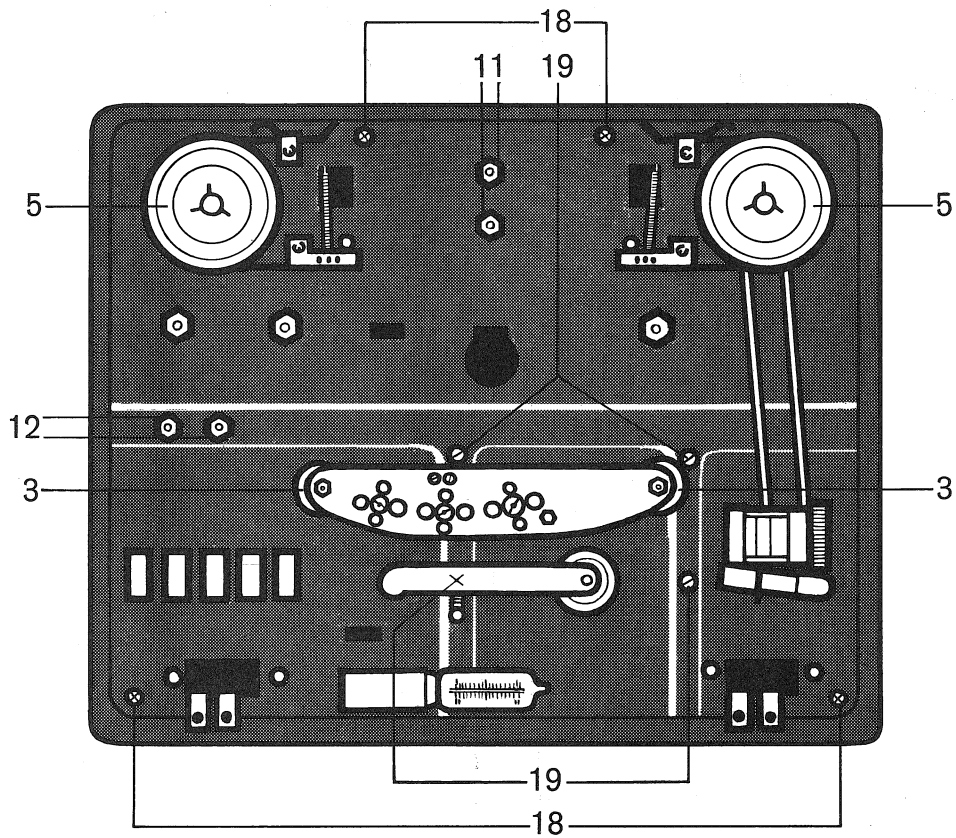

Fig. 2

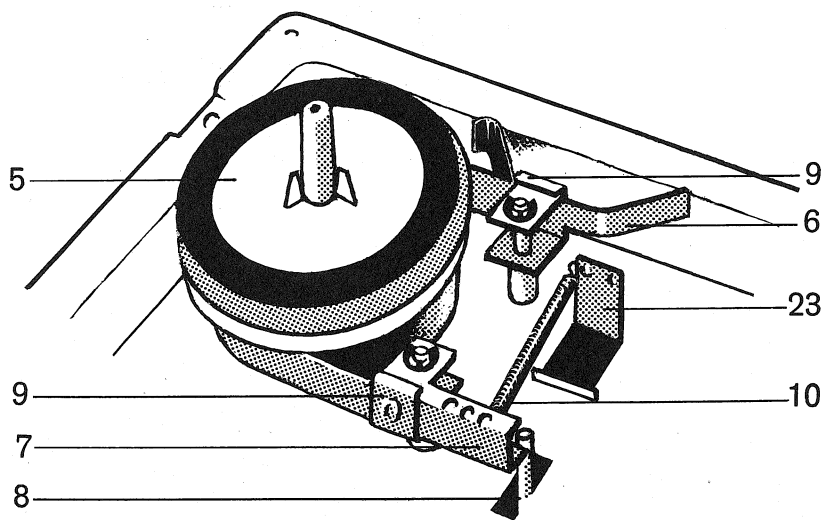

Fig. 3



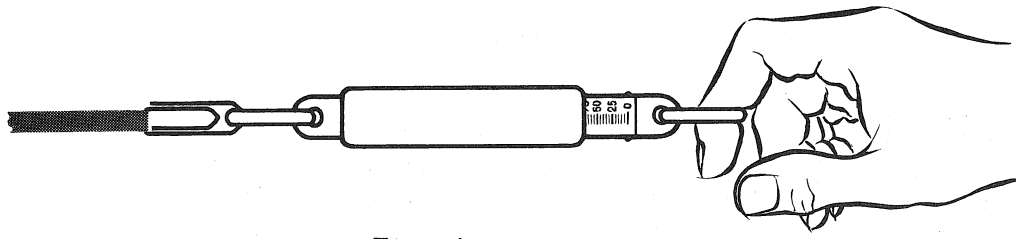

Fig. 4

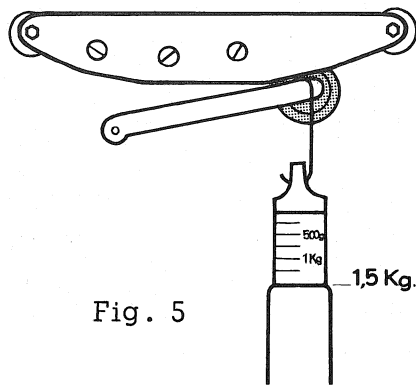

Fig. 5

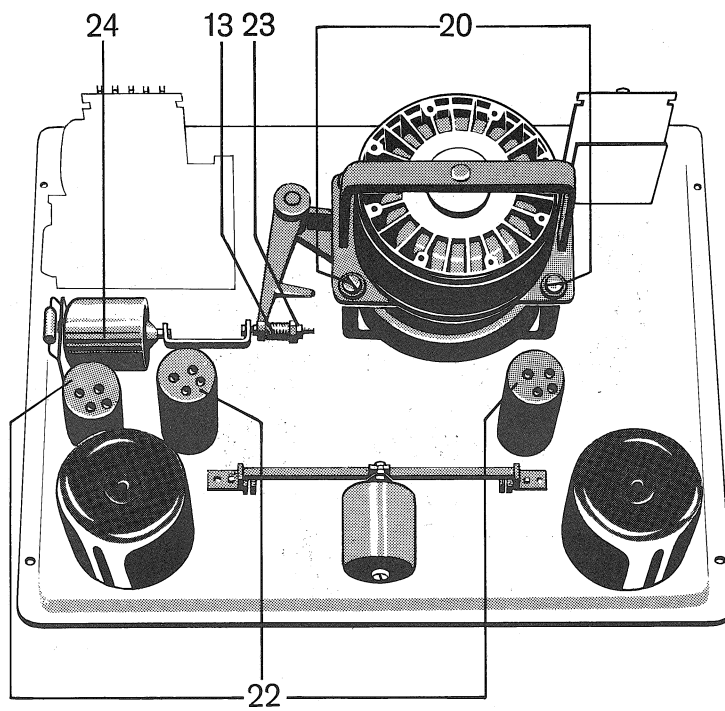

Fig. 6

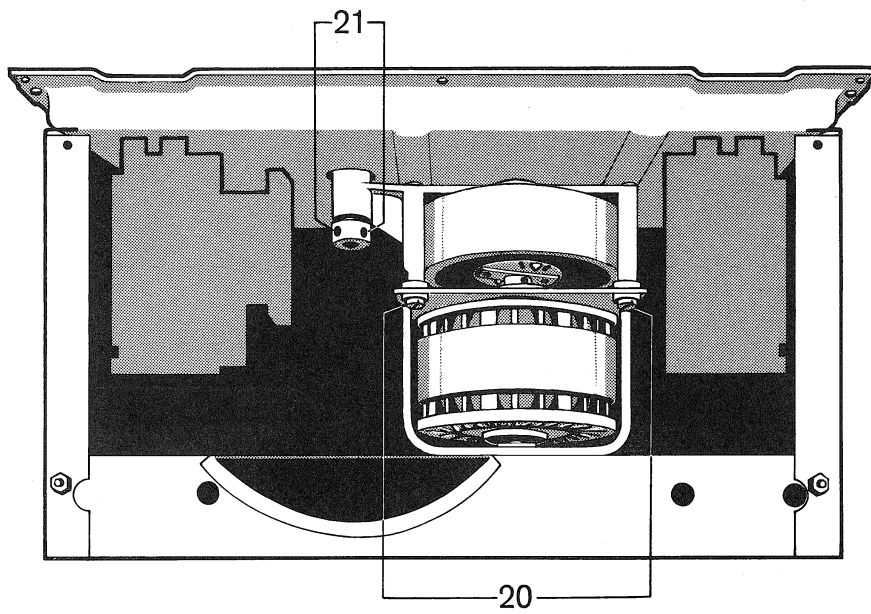

Fig. 7

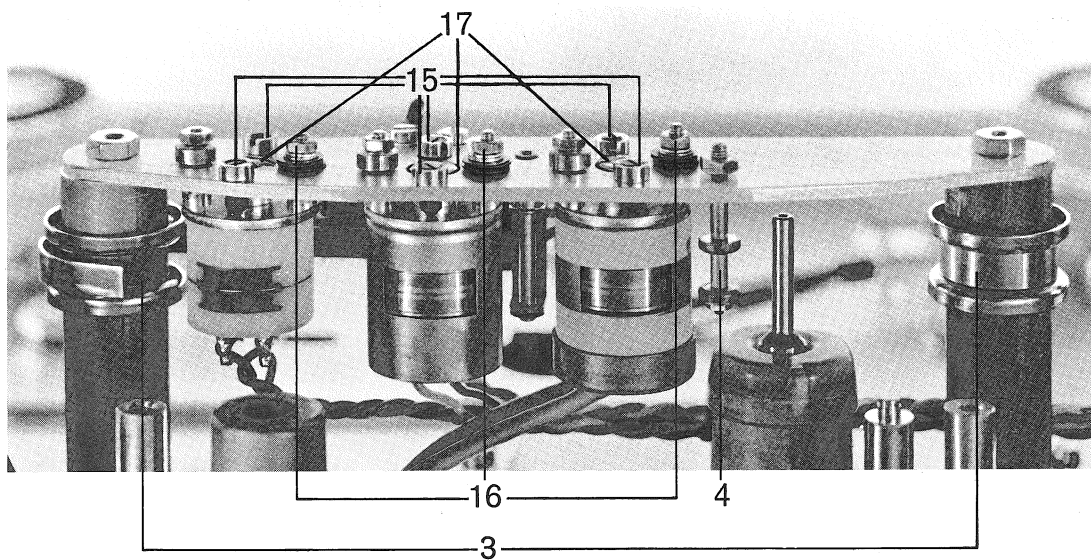
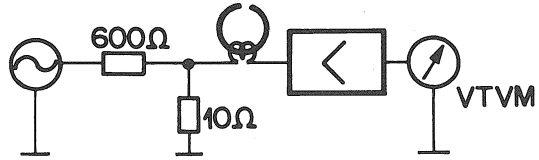

Fig. 9

Play-back equalization



f c/s	NAB D/E 36		CCIR D/E 36		DIN F 36	
	7 1/2 [db]	3 3/4 [db]	7 1/2 [db]	3 3/4 [db]	7 1/2 [db]	3 3/4 [db]
40	+ 20,5	+ 19,5	+ 22,5	+ 19	+ 19,5	+ 18
60	+ 19,5	+ 18,5	+ 20,5	+ 17,5	+ 19	+ 17,5
125	+ 16	+ 15,5	+ 15,5	+ 13	+ 17,5	+ 14
250	+ 11	+ 10,5	+ 10	+ 8	+ 10	+ 7,5
500	+ 5,5	+ 5	+ 5,5	+ 3	+ 5	+ 3,5
1000	0	0	0	0	0	0
2000	- 4,5	- 2,5	- 3	- 1,5	- 3	- 2
4000	- 7	- 3	- 4	- 1	- 4,5	- 1,5
6000	- 7,5	- 2,5	- 4	+ 0,5	- 4,5	0
8000	- 7	- 0,5	- 3	+ 2,5	- 4	+ 1,5
10000	- 6	+ 1,5	- 2	+ 4,5	- 3,5	+ 3
12000	- 5	+ 1	- 1	+ 4	- 3	+ 3,5

Recording pre-emphasis

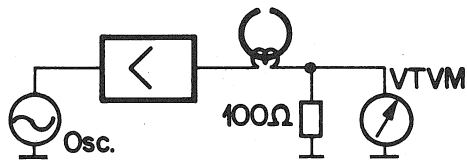

f c/s	D/E 36		F 36	
	7 1/2 [db]	3 3/4 [db]	7 1/2 [db]	3 3/4 [db]
40	+ 3,5	+ 3,5	+ 3	+ 3
60	+ 2,5	+ 2,5	+ 1,5	+ 1,5
125	+ 0,5	+ 0,5	0	0
250	0	0	0	0
500	0	0	0	0
1000	0	0	0	0
2000	+ 0,5	+ 1,5	0	+ 0,5
4000	+ 2	+ 5,5	+ 1	+ 2,5
6000	+ 4	+ 9,5	+ 2,5	+ 5
8000	+ 6	+ 13,5	+ 4	+ 8
10000	+ 9	+ 17,5	+ 6	+ 10,5
12000	+ 12,5	+ 21	+ 8	+ 14

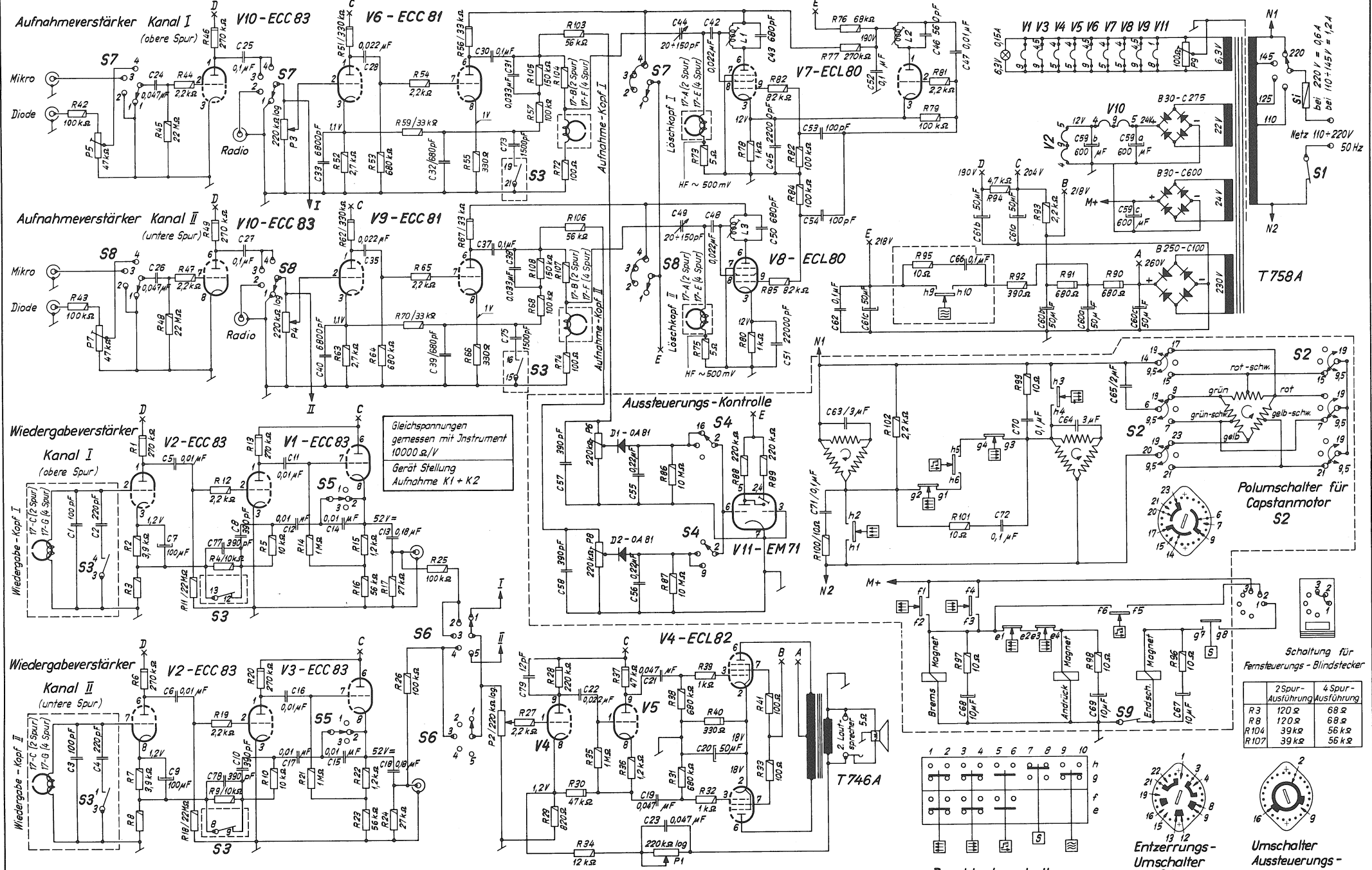

**Wiedergabeentzerrungs-Umschalter S5**

- Off, Netz aus
- CCIR, Netz ein, Entz. nach CCIR (Europa)
- NAB, Netz ein, Entz. nach NAB (USA)

Die Achse dieses Schalters ist mit dem Netzschalter S1 gekuppelt.

**Monitorverstärker - Umschalter S6**

1. Input I Eingang Kanal I direkt
2. Tape I ab Band Kanal I
3. Tape I+II ab Band Kanal I und II
4. Tape II ab Band Kanal II
5. Input II Eingang Kanal II direkt

**Eingangs - Umschalter S7+S8**

1. Off Kanal aus (keine Aufn.)
2. R Eingang Radio
3. M Eingang Mikro
4. D Eingang Diode

Alle Schalter sind in folgender Betriebsstellung gezeichnet:

Netz : Ein  
Gerät : Stopp, kein Band eingelegt  
Geschwindigkeit : 19 cm / sek.  
Wiedergabeentzerrung (S5) : CCIR

Mit --- eingefasste Schaltelemente gehören zum Laufwerk

**REVOX Stereo**  
Modell D36 50 Hz  
2 und 4 Spur-Ausführung  
Erste Nr. S-D 36 [ab Geräte-Nr. 18001]

2 Spur-Ausführung	4 Spur-Ausführung
R3 120 kΩ	R8 68 kΩ
R8 120 kΩ	R3 68 kΩ
R104 39 kΩ	R56 56 kΩ
R107 39 kΩ	R56 56 kΩ

Hersteller: REVOX ZÜRICH

Schaltung für Fernsteuerungs-Blindstecker

2 Spur-Ausführung	4 Spur-Ausführung
R3 120 kΩ	R8 68 kΩ
R8 120 kΩ	R3 68 kΩ
R104 39 kΩ	R56 56 kΩ
R107 39 kΩ	R56 56 kΩ

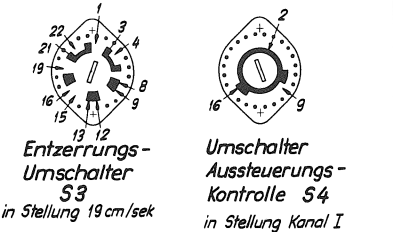



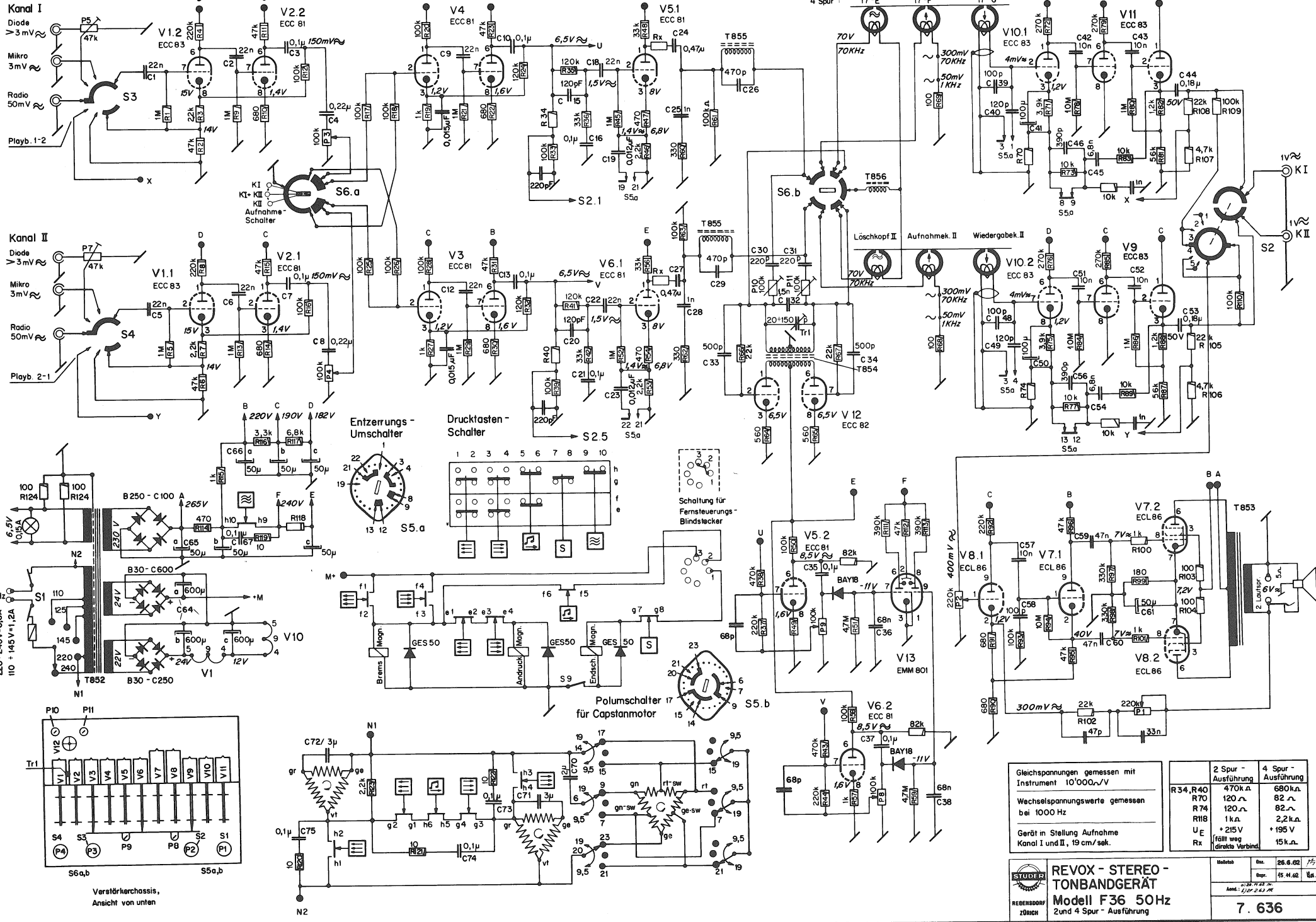

Gleichspannungen gemessen mit Instrument 10'000Ω/V

Wechselspannungswerte gemessen bei 1000 Hz

Gerät in Stellung Aufnahme Kanal I und II, 19 cm/sek.

	2 Spur - Ausführung	4 Spur - Ausführung
R34, R40	470kΩ	680kΩ
R70	120Ω	82Ω
R74	120Ω	82Ω
R118	1kΩ	2,2kΩ
UE	+215V	+195V
Rx	fällt weg (direkte Verbind.)	15kΩ

**STUDEER** REVOX - STEREO - TONBANDGERÄT Modell F36 50Hz 2 und 4 Spur - Ausführung

Hersteller: REBERSDORF ZÜRICH

Best.-Nr.: 26.6.02 / 1/3  
 Impr.: 45.4.02 / 1/3  
 7. 636

Verstärkerchassis, Ansicht von unten