

# TASCAM

TEAC Professional Division



## SERVICE MANUAL

# 122MKII

## Master Cassette Deck

# TABLE OF CONTENTS

## 目 次

1. Specifications .....	2	1. 仕様 .....	2
Block Diagram .....	3	ブロック・ダイヤグラム .....	3
2. Removal of External Components .....	4	2. 外装部品の外し方 .....	4
3. Parts Location .....	5	3. 部品配置図 .....	5
4. Test Equipment/Material and Precautions		4. メンテナンス主要器材と諸条件	
4-1 Equipment Required for Maintenance .....	7	4-1. メンテナンス主要器材 .....	9
4-2 Precautions .....	8	4-2. メンテナンス諸条件 .....	10
5. Mechanical Checks and Adjustments		5. 機構部のチェックと調整	
5-1 Micro Switch .....	11	5-1. マイクロスイッチ .....	11
5-2 Head Hight, Tilt and Azimuth .....	11	5-2. ヘッドの高さ、チルト、アジマス .....	11
5-3 Head Base Position .....	12	5-3. ヘッドベース位置 .....	12
5-4 Pinch Roller Pressure .....	15	5-4. ピンチ・ローラ圧着力 .....	15
5-5 Reel Torque .....	15	5-5. リール・トルク .....	15
5-6 Tape Speed .....	16	5-6. テープ速度 .....	16
5-7 Wow and Flutter .....	17	5-7. ワウ・フラッタ .....	17
5-8 Cassette Holder .....	17	5-8. カセット・ホルダ .....	17
5-9 Damper Adjustment .....	18	5-9. ダンパ調整 .....	18
5-10 Voltage Conversion .....	18	5-10. 電圧変換 .....	18
6. Electrical Checks and Adjustments		6. 録音再生アンプ部のチェックと調整	
6-1 Playback Performance .....	21	6-1. 再生系 .....	21
6-2 Monitor Performance .....	22	6-2. モニタ系 .....	22
6-3 Recording Performance .....	23	6-3. 録音系 .....	23
7. Exploded Views and Parts Lists .....	25	7. 分解図とパーツ・リスト .....	25
8. PC Boards and Parts Lists .....	34	8. 基板図とパーツ・リスト .....	34
9. IC Internal Block Diagrams .....	44	9. ICブロック・ダイヤグラム .....	44
Schematic's .....	Insert	回路図 .....	投げ込み

# 1. SPECIFICATIONS

## 仕様

### MECHANICAL

<b>Tape:</b>	Philips type cassette C-60 and C-90
<b>Track Format:</b>	4-track, 2-channel stereo
<b>Tape Speed:</b>	4.8 cm/s (1-7/8" ips)
<b>Speed Accuracy:</b>	±0.5 %
<b>Pitch Control:</b>	±12 %
<b>Wow &amp; Flutter<sup>1)</sup>:</b>	0.04 % (NAB weighted) ±0.08 % peak (DIN/IEC/ANSI weighted)
<b>Fast Wind Time:</b>	90 seconds for C-60
<b>Motor:</b>	1 FG servo direct-drive capstan motor; 1 DC reel motor; and 1 DC ancillary
<b>Head Configuration:</b>	3 heads; erase, playback and record
<b>Dimensions (W x H x D):</b>	482 x 133 x 297 mm (19" x 5-1/4" x 11-11/16")
<b>Weight:</b>	7.7 kg (16.94 lbs) net

### ELECTRICAL

<b>Line Input (XLR)</b>	
<b>Input Impedance:</b>	40 k ohms, balanced
<b>Nominal Input Level:</b>	+4 dBm (1.23 V)
<b>Minimum Input Level:</b>	-4 dBm (0.49 V)
<b>Line Input (1/4" and RCA)</b>	
<b>Input Impedance:</b>	30 k ohms, unbalanced
<b>Nominal Input Level:</b>	-10 dBV (0.3 V)
<b>Minimum Input Level:</b>	-18 dBV (126 mV)
<b>Line Output (XLR)</b>	
<b>Minimum Load Impedance:</b>	10 k ohms or more, balanced
<b>Output Impedance:</b>	100 ohms
<b>Nominal Output Level:</b>	+4 dBm (1.23 V)
<b>Maximum Output Level:</b>	+12 dBm (3.1 V)
<b>Line Output (RCA)</b>	
<b>Minimum Load Impedance:</b>	10 k ohms or more, unbalanced
<b>Output Impedance:</b>	100 ohms
<b>Nominal Output Level:</b>	-10 dBV (0.3 V)
<b>Maximum Output Level:</b>	-2 dBV (0.8 V)
<b>Headphone Output:</b>	100 mW/channel maximum at 8 ohms
<b>Bias Frequency</b>	100 kHz
<b>Equalization:</b>	3180 $\mu$ s + 70 $\mu$ s (Metal, CrO <sub>2</sub> ) 3180 $\mu$ s + 120 $\mu$ s (Normal)
<b>Recording Level:</b>	160 nWb/m (0 VU)
<b>Frequency Response<sup>2)</sup>:</b>	25 Hz - 20 kHz $\pm$ 3 dB at -20 VU (Metal) 25 Hz - 19 kHz $\pm$ 3 dB at -20 VU (CrO <sub>2</sub> ) 25 Hz - 17 kHz $\pm$ 3 dB at -20 VU (Normal)
<b>Total Harmonic Distortion (THD)<sup>2)</sup>:</b>	1 % at 0 VU, 400 Hz, 160 nWb/m (Metal)
<b>Signal-to-Noise Ratio<sup>2)</sup>:</b> (Reference 3 % THD)	59 dB (NR OUT, WTD) 68 dB (DOLBY*-B NR IN, over 5 kHz) 78 dB (DOLBY-C NR IN, over 1 kHz)
<b>Adjacent Channel Separation<sup>2)</sup>:</b>	Better than 45 dB at 1 kHz
<b>Erase<sup>2)</sup>:</b>	Better than 65 dB at 1 kHz reference +10 VU
<b>Power Requirements:</b>	
<b>U.S.A./CANADA:</b>	120 V AC, 60 Hz
<b>EUROPE:</b>	220 V AC, 50 Hz
<b>U.K./AUSTRALIA:</b>	240 V AC, 50 Hz
<b>GENERAL EXPORT:</b>	100/120/220/240 V AC, 50/60 Hz
<b>Power Consumption:</b>	24 W

In these specifications, 0 dBV is referenced to 1.0 Volt. Actual voltage levels are also given in parenthesis. To calculate the 0 dB = 0.775 Volt reference level (i.e., 0 dBm in a 600-ohm circuit), add 2.2 dB to the listed dB value; i.e., -10 dB re: 1 V = -7.8 dB re: 0.775 V.

1) Specifications were determined using TEAC Test Tape MTT-111

2) Specifications were determined using TEAC Test Tape

METAL MTT-5571

CrO<sub>2</sub> MTT-5561

NORMAL MTT-5511

基準レベルは0dBV=1V, 0dBm=0.775Vで実際の電圧も( )で示しています。

0dBm=0.775V基準レベルと0dB=1V基準レベルとは2.2dBの差があります。

1): この項の仕様は、テスト・テープTEAC MTT-111によります。

2): この項の仕様のテスト・テープは  
METAL MTT-5571  
NORMAL MTT-5511  
CrO<sub>2</sub> MTT-5561

☆ 仕様及び外観は改善のため予告なく変更することがあります。

☆ ドルビーノイズリダクションシステムは、ドルビー研究所からの実施権に基づき製造されています。

☆ ドルビー及び  は、ドルビー研究所の登録商標です。

Changes in specifications and features may be made without notice or obligation.

\*Dolby noise reduction manufactured under license from Dolby Laboratories Licensing Corporation.

"DOLBY" and the double-D symbol  are trademarks of Dolby Laboratories Licensing Corporation.

# Block Diagram

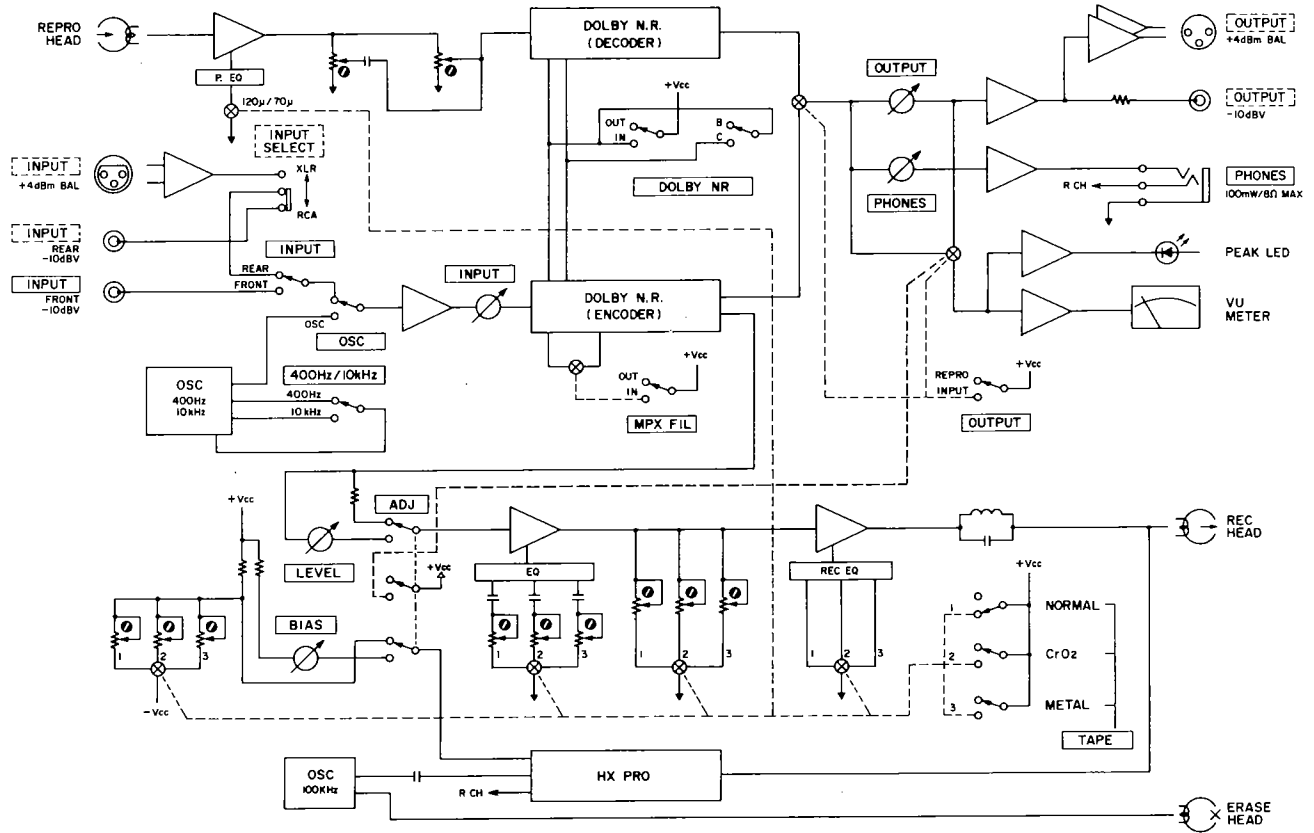

# External Dimensions

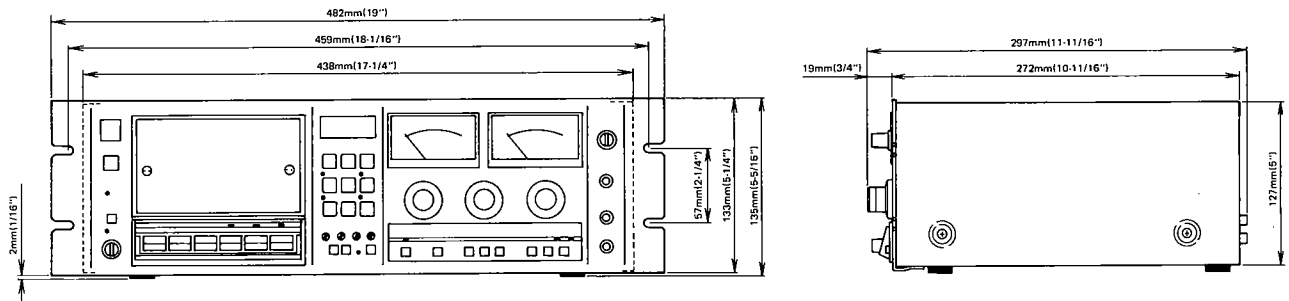

## 2 REMOVAL OF EXTERNAL COMPONENTS

外装部品の外し方

Disassemble in number-order  
番号順に外して下さい

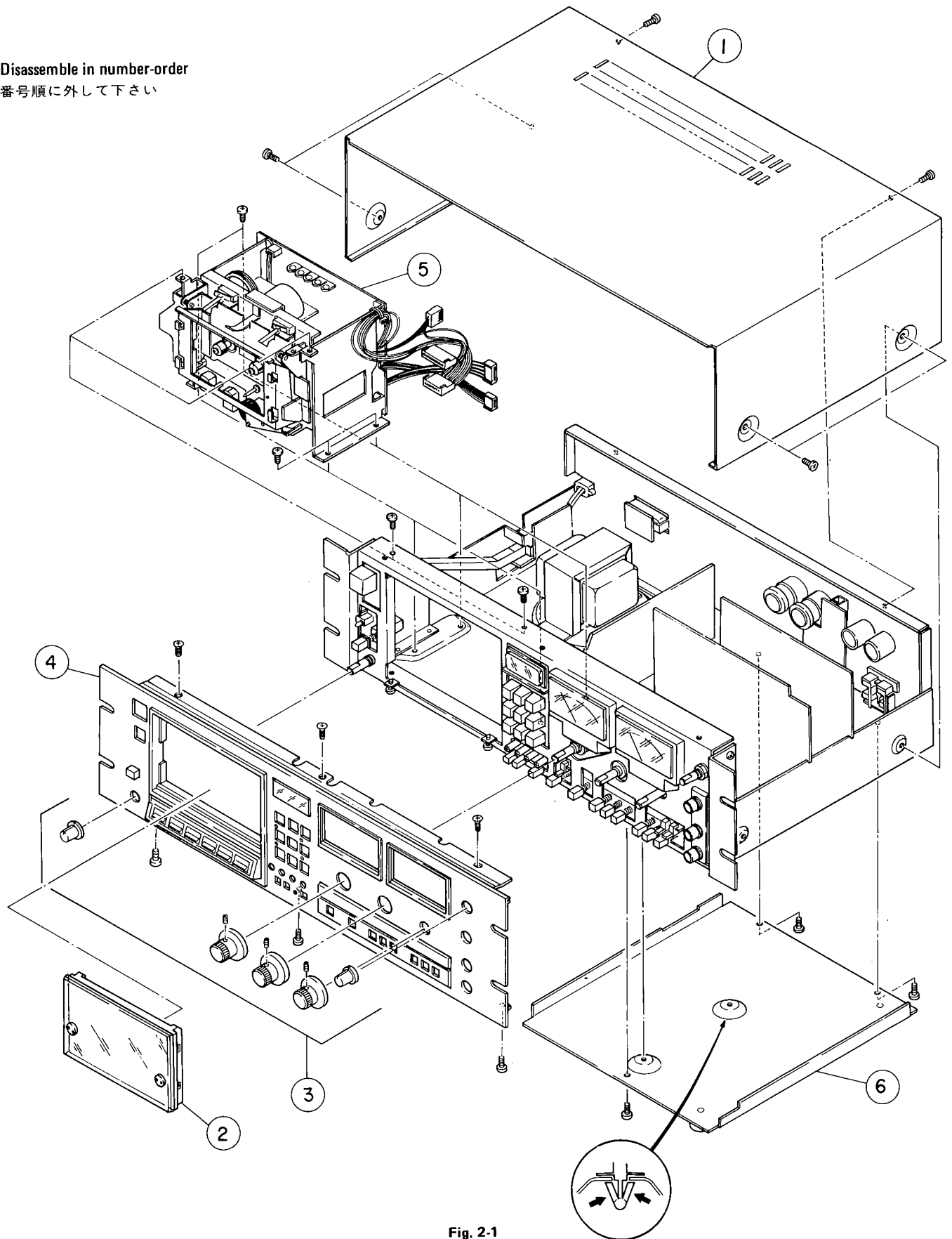
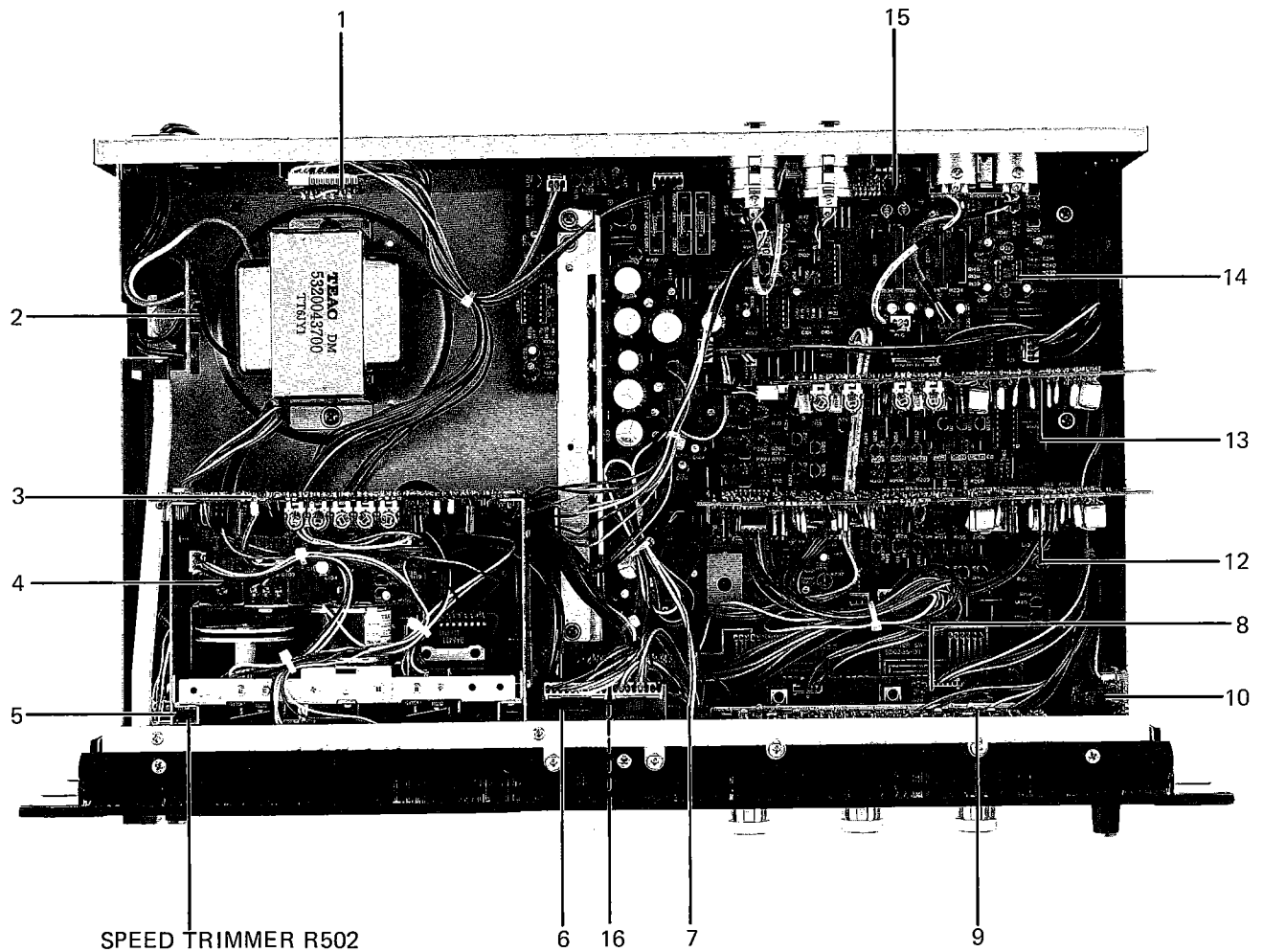

Fig. 2-1

## 3 PARTS LOCATION

部品配置図



11

1	REMOCON PCB ASSY	9	METER PCB ASSY
2	POWER SW PCB ASSY	10	H. PHONE PCB ASSY
3	CONTROL PCB ASSY	11	MONITOR SW PCB ASSY
4	B. T CONTROL PCB ASSY	12	REC AMP PCB ASSY
5	PITCH CON PCB ASSY	13	PLAY AMP PCB ASSY
6	COUNTER PCB ASSY	14	MOTHER PCB ASSY
7	COUNTER SW PCB ASSY	15	BAL. AMP PCB ASSY
8	VR PCB ASSY	16	JOINT PCB ASSY, ADJ SW PCB ASSY

Fig. 3-1 Top view  
上面図

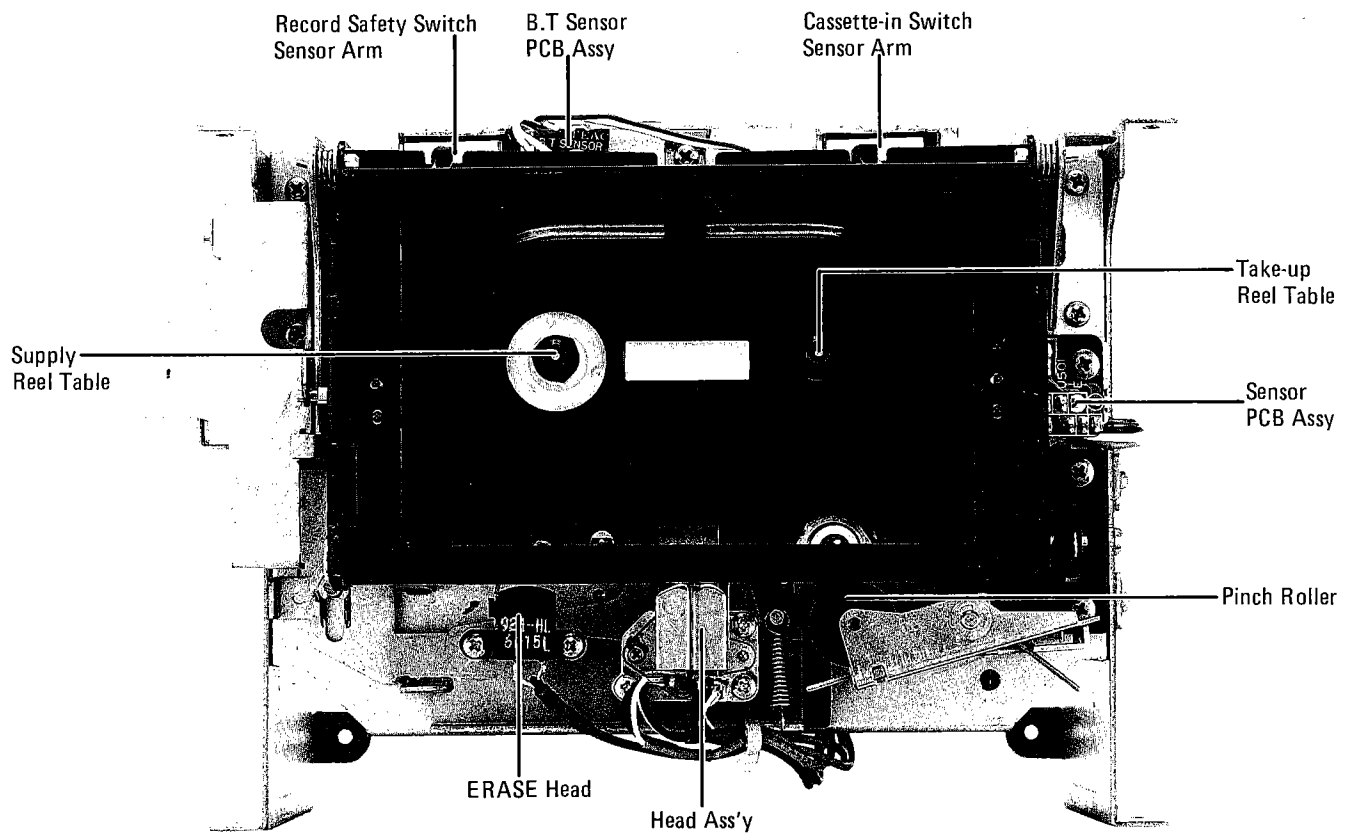

Fig. 3-2

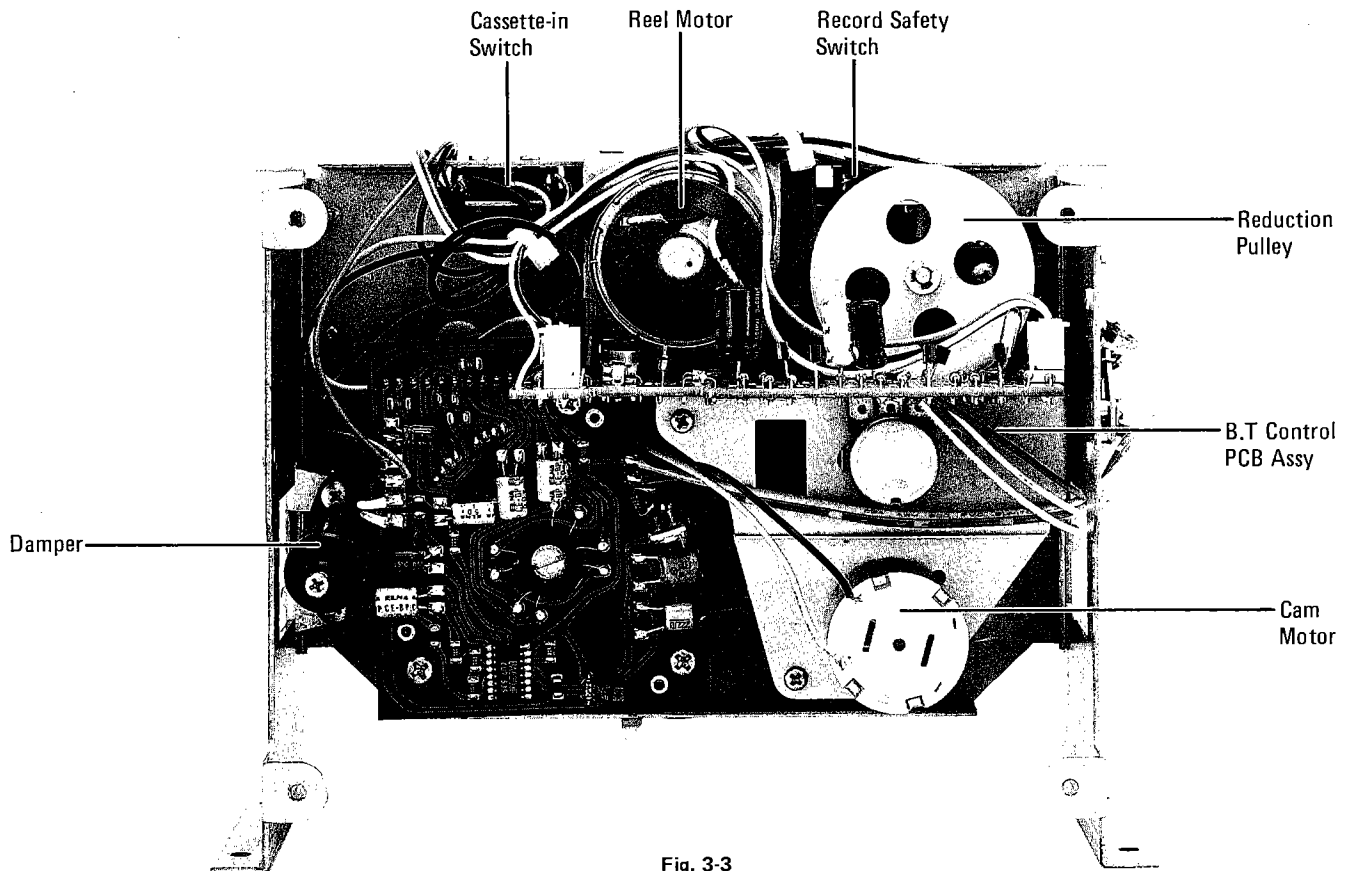

Fig. 3-3



## 4. TEST EQUIPMENT/MATERIAL AND PRECAUTIONS

### 4-1. EQUIPMENT REQUIRED FOR MAINTENANCE

Equipment/Material (Suggested Type)		Used for
Cleaner	TEAC TZ-261A (Head Cleaner) or equivalent	Cleaning heads and other meal components in tape path
	TEAC TZ-261B (Rubber Cleaner)	Cleaning pinch collars
Head Demagnetizer	TEAC E-3 or equivalent	Demagnetizing heads
Screwdriver	Non inductive (plastique, wood)	Bias tuning
Spring Scale	0 – 500 g	Pinch roller pressure measurement
Head Alignment Jig	Jig A, TEAC Part No. 5736006600 Jig B, TEAC Part No. 5736006700	Head height checks (longitudinal and horizontal)
Torque Meter	Cassette torque meter 0 – 100 g-cm (Sony model TW2111/2121) 0 – 160 g-cm (Sony model TW2231)	Reel torque measurement
Wow/Flutter Meter	General use type Range: 0.03 % Sensitivity: 10 mV or more Available positions: NAB, DIN/CCIR; WTD/UNWTD	Wow and Flutter measurements
Frequency Counter	General use type Sensitivity: 25 mV or more Impedance: 1 M ohms or more Range: 1 Hz – 10 MHz	Tape speed measurement, Wow/flutter measurement, and Bias frequency measurement
DC Voltmeter	General use type Digital or analog Sensitivity: 0.1 V or more	DC voltage measurements
AC Level Meter	General use type Level range: -80 dB – +40 dB Impedance: 1 M ohms or more, less than 25 pF Frequency range: 30 kHz or more	Signal level measurements and bias adjsutments
Oscillator	Available frequencies: 10 Hz – 1 MHz Output level: 3 V or more/600 ohms (variable) Distortion: less than 0.1 %	Test signal generation
Attenuator	General use type Attenuation: 100 dB or more Steps: 0.1 dB Impedance: 600 ohms	Input level settings
Oscilloscope	General use type (2 channel) Sensitivity: 20 mV/DIV or more Sweep rate: 1 $\mu$ sec/DIV or more	Head azimuth adjustment
Distortion Meter	General use type Frequency: 400 Hz, 1 kHz Sensitivity: 10 mV or more Scale range: 0.1 % or wider	Output distortion check
Band-pass Filter	General use type Passing band width: 1 kHz ( $\pm$ 10 %), 30 dB or more/octave Weighting: IHF	Erasure and Crosstalk measurements

Equipment/Material (Suggested Type)		Used for
Test Tapes	TEAC MTT-111 (Part No. 4900010100)	Tape speed and wow/flutter measurements
	TEAC MTT-150 (Part No. 4900011100) (Dolby-B type)	Output level adjustment
	TEAC MTT-256 (Part No. 490005090) DIN reference level Time constant 3180 + 120 $\mu$ sec. 31.5Hz~14kHz	Head azimuth and Frequency response adjustment
Blank Tapes	TEAC MTT-5511 (Part No. 4900041700) (NORMAL)	Test signal recordings and others
	TEAC MTT-5561 (Part No. 4900041900) (CrO2)	
	TEAC MTT-5571 (Part No. 4900042000) (METAL)	
Mirror Tape	TEAC MTT-902 (Part No. 4900015200)	Tape travel check

#### 4-2. PRECAUTIONS

1. Before making any electrical checks and adjustments, be sure to clean and demagnetize each head and tape path; and also make sure that the tape runs smoothly.
2. Repeat checks and adjustments for L and R channels in this order except otherwise specified.

**Note:** Adjustment pot numbers indicated as R00/R00 refer

3. to channel L and channel R circuitries, respectively.

In this manual, 0 dBV is referenced to 1.0 V.

## 4. メンテナンス主要器材と諸条件

## 4-1 メンテナンス主要器材

機	材 (指定品)	目 的
クリーニング液	TEAC TZ-261A液 (ヘッドクリーナ) および同等品	ヘッド、テープ・ガイド面のクリーニング
	TEAC TZ-261B液 (ラバー・クリーナ) および同等品	ピンチ・ローラのクリーニング
ヘッド・イレーサ	TEAC E-3および同等品	ヘッド・テープ・ガイドの消磁
ドライバー	無誘導性 (プラスチック, 木製)	バイアス・チューニング
ばね秤	0~500g	ピンチ・ローラ圧着測定
ヘッド高さ調整用治具	治具A (品番5736006600) 治具B (品番5736006700)	ヘッドの高さ, 位置測定
トルク・メータ	カセット・トルク・メータ 0~100g-cm (ソニー製 TW2111, 2121) 0~160g-cm (ソニー製 TW2231)	リール・トルク
ワウ・フラッタ・メータ	一般用 レンジ: 0.03%~ 感度: 10mV以上 特性: JIS, NAB, DIN/CCIR WTD/UNWTD	ワウ・フラッタ測定
周波数・カウンター	一般用 感度: 25mV以上 インピーダンス: 1M $\Omega$ 以上 測定周波数: 1Hz~10MHz	テープ・スピード測定 ワウ・フラッタ測定 バイアス発振周波数測定
直流電圧計	一般用 デジタルまたはアナログ式 感度: 0.1V以上	電圧測定
AC・レベル計	一般用 レンジ: -80dB~+40dB インピーダンス: 1M $\Omega$ 以上, 25pF以下 周波数帯域: 30kHz以上	信号レベル測定 バイアス調整
オーディオ発振器	周波数: 10Hz~1MHz 出力レベル: 3V以上/600 $\Omega$ (可変) ひずみ率: 0.1%以下	入力信号
アッテネータ	一般用 減衰量: 100dB以上 ステップ: 0.1dB インピーダンス: 600 $\Omega$	入力信号レベル設定
オシロスコープ	一般用 (二現象) 感度: 20mV/DIV以上 掃引時間: 1 $\mu$ sec/DIV以上	ヘッド・アジマス調整
ひずみ率計	一般用 周波数: 400Hz, 1kHz 感度: 10mV以上 測定範囲: 0.1%以上	出力信号のひずみ率測定

バンド・パス・フィルタ	一般用 帯域：1 kHz (±10%) 30dB以上/OCT 帯域：聴感補正IHF規格	消去効果測定 クロストーク測定
ミラー・テープ	TEAC MTT-902 (4900015200)	テープ走行
テスト・テープ	TEAC MTT-111 (4900010100)	テープ速度、ワウ・フラッタ用
	TEAC MTT-150 (4900011100) ; Dolby B-Type	レベル用
	TEAC MTT-256 ; DIN Ref. Level, (4900050900) 時定数3180 + 120 $\mu$ sec 31.5Hz~14kHz	ヘッド・アジマス, 周波数特性用
	TEAC MTT-5511 (4900041700) TEAC MTT-5561 (4900041900) TEAC MTT-5571 (4900042000)	ブランク・テープ (NORMAL) ブランク・テープ (CrO <sub>2</sub> ) ブランク・テープ (METAL)

#### 4-2 メンテナンス諸条件

1. アンプ部の調整のまえに、消去ヘッド、録音ヘッド、テープ走行部分それぞれを充分消磁し、クリーナ液で清掃してテープ走行状態を確認する。
2. 特に指定の無い限り、調整及びチェックはL-ch, R-chの順序で行って下さい。  
尚R00/R00, R000/R000のように記されている回路番号はL-ch/R-chを示します。
3. 0dBV=1.0V

## 5. MECHANICAL CHECKS AND ADJUSTMENTS

### 機構部のチェックと調整

#### 5-1 MICRO SWITCH

1. Prepare a standard cassette shell with the record protection tabs in place.
2. Load this cassette and close the cassette holder.
3. Adjust mounting position of the two micro switches, cassette-in switch (S502) and record safety switch (S501) (for switch location, refer to Fig. 3-3, so that the actuator position is in the setting range shown by Fig. 5-1.
4. Be sure that the cassette-in switch is properly actuated to start the capstan motor.
5. Make sure that the record safety switch is properly actuated so that when depressing the RECORD button together with the PLAY button, the deck is set in record mode (or can not be set in record mode if the cassette loaded has no tabs).

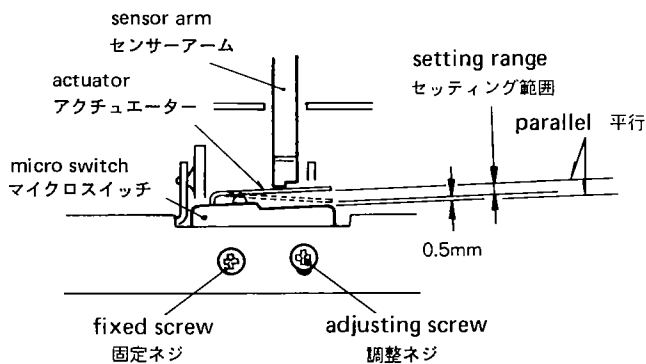

Fig. 5-1

#### 5-2. HEAD HEIGHT, TILT AND AZIMUTH

1. Set head check jigs A and B.
2. Adjust height adjusting screw A shown in Fig. 5-4 so that tip of non-marked side of the jig B does not touch the guide of the rec/PB head, but the red marked side touches the guide.
3. Apply jig B to head and check for tilt. (Fig. 5-3)  
Adjust tilt adjusting screw B (Fig. 5-4) as required. After completion of the adjustment, make sure the head height adjustment is not upset, using the step 2 above.
4. Adjust P/B head azimuth by adjusting screw C referring to item 6-1.  
Adjust rec head azimuth by turning adjusting screw D slightly referring to item 6-3.  
After adjustment, repeat steps 2 and 3.

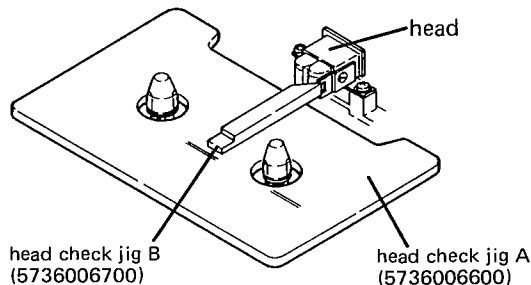

Fig. 5-2

#### 5-1 マイクロ・スイッチ

1. 誤消去防止用ツメ付の標準カセットを用意する。
2. このカセットを装てんし、カセット・ホルダを閉じる。
3. カセットイン・スイッチ (S502)、録音防止スイッチ (S501) 共 (両スイッチ取付個所は図3-3を参照)、アクチュエータ位置が図5-1のセッティング範囲内になるようにスイッチ取付位置を調整する。
4. カセットイン・スイッチが正しく作動してキャプスタン・モータが回転するか確認する。
5. 録音防止スイッチが正しく作動して、RECORD 釦とプレイ 釦を一緒に押すと、確実に録音ができるか (または誤消去防止用ツメが付いていないカセットを装てんの場合には録音できないか) 確認する。

#### 5-2 ヘッドの高さ、チルト、アジマス

1. ヘッドの位置調整治具 A, B をセットする。
2. 治具 B の無印側では録再ヘッドのガイドに当らず赤マーク側でガイドに当るように図5-4のヘッド調整ネジ (A) で調整する。(図5-2)
3. 治具 B をヘッドに当てチルトを確認する。(図5-3)  
調整はネジ (B) で行なう。(図5-4)  
調整を行なった後、高さが狂わなかったステップ2で再チェックする。
4. 再生ヘッドのアジマスは6-1項に従って調整ネジ (C) で行なう。  
録音ヘッドは6-3項に従って調整ネジ (D) で行なう。  
調整ネジ (D) は僅かな回転 (1回転) でよい。  
調整を行なった後は、ステップ2の高さ、ステップ3のチルトを再チェックしてください。

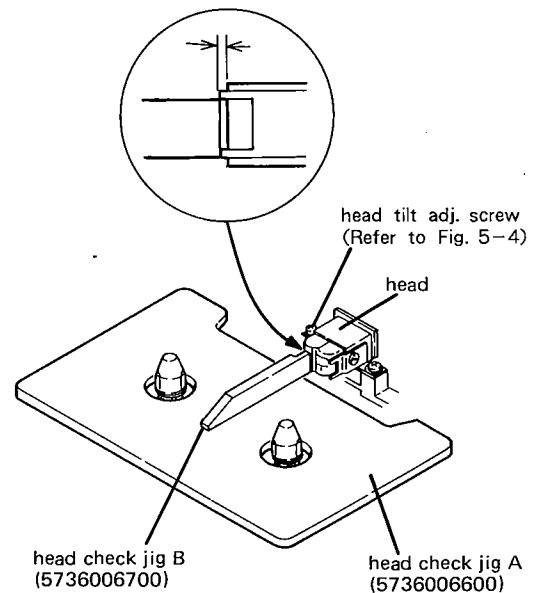

Fig. 5-3

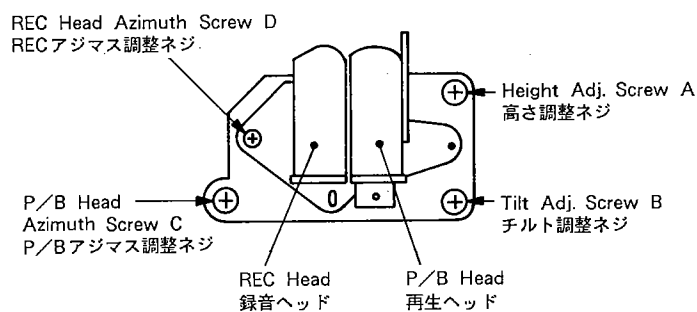

Fig. 5-4

### 5-3 HEAD BASE POSITION

#### 5-3-1 STOP MODE

1. With the deck in STOP mode, adjust the trim pot R547 (Fig. 5-3) so that the head base comes to the lowest position.
2. Turn the reduction pulley (see Fig. 3-3) with your hand to check whether the head base exceeds the lowest position adjusted above or not.
3. If it does, adjust R547 again.
4. Repeat steps 1 through 3 until a good result is achieved.
5. Operate the deck in the sequence of PLAY, STOP, PLAY, and finally power-off modes. Repeat this sequence two or three times.
6. Then observe the stop position of the head base. If the head base still exceeds than the position in step 3, readjust R547 and repeat steps 1 through 5 until the head base comes to the lowest position.

#### 5-3-2 F.F./REW MODES

1. Run the deck in the F.F. (fast forward) or REW (rewind) mode and adjust the trim pot R544 (Fig. 5-6) so that the following two conditions are obtained.
  - a) A clearance between brake drum and brake pad ("A" in Fig. 5-7) of approx. 1.5 to 2 mm.
  - b) Head base should not go too far up (so the heads do not touch the moving tape, and quick braking action is possible).
2. Repeat switching operations from the STOP mode to F.F. or REW mode two or three times and make sure the above adjustment is satisfied.

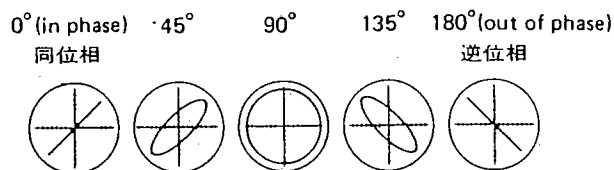

Fig. 5-5

### 5-3 ヘッド・ベース位置

#### 5-3-1 ストップ・モード時

1. ストップ・モード時に、ヘッド・ベースが最も下方にくるように半固定抵抗 R547 (図5-6) を調整する。
2. 減速プーリ (図3-3参照) を手で回転させ、ヘッド・ベースが上記の調整位置よりさらに下へくるかどうか確認する。
3. もし下へくるようならば、R547をさらに調整する。
4. 1~3項を繰り返して、結果が良くなるようにする。
5. プレイ・モードからストップ・モード、そしてプレイ・モードから電源を切る操作を2,3度繰り返す。
6. 5項を終了後、ヘッド・ベースの停止位置を見る。もし、3項で調整された位置より下にくるようならば、R547をさらに調整し次に1~5項を繰り返して、ヘッド・ベースが最も下にくるようにする。

#### 5-3-2 F.F./RWDモード時

1. F.F (早送り) または RWD (早巻戻し) モード中に下記の状態が得られるように半固定抵抗 R544 (図5-6) を調整する。
  - ブレーキ・ドラムとブレーキ・パッドのすき間 (図5-7のA) が約1.5mm~2mmであること。
  - ヘッド・ベースはできるだけ上方へ行かないこと・・・走行中のテープが各ヘッドに当たらない状態を得る為、およびブレーキのタイミングをできるだけ早くする為。
2. ストップ・モードからF.F., またはRWDモードへの切換え操作を2, 3度繰り返し上記の調整を満足しているか確認する。

### 5-3-3 PAUSE MODE

1. With the deck in the play mode, check that there is clearance of 0.5 mm or more between the pinch roller arm and the spring arm ("D" in Fig. 5-8).
2. Set the deck to PAUSE mode and observe the clearance between the pinch roller and capstan shaft ("B" in Fig. 5-7). It should be 0.5 mm or more.
3. If not, adjust the trim pot R545.
4. Repeat switching operations from STOP to PAUSE mode two or three times, and make sure that when repeating steps 1 and 2, the clearances "D" and "B" are within the specified range respectively. Also make sure there is a clearance between head base and spring stud ("C" in Fig. 5-8).

### 5-3-4 CUE MODE

1. Load a prerecorded tape.

Make sure cue signal is developed when the FF or REW button is pushed with the PAUSE mode set. If the cue signal is not developed or the level is excessively low, adjust the trim pot R546 (Fig. 5-6).

### 5-3-3 ポーズ・モード時

1. プレイ・モードにして、ピンチ・ローラ・アームとスプリング・アームのすき間 (図5-8のD) が約0.5mm以上であるか確認する。
2. ポーズ・モードの時にピンチ・ローラとキャプスタン・シャフトの間隔 (図5-7のB) が約0.5mm以上であるか確認する。
3. もし外れている場合は、半固定抵抗 R545 で調整する。
4. ストップ・モードからポーズ・モードへの切換え操作を2, 3度繰り返した後、再度1, 2項のチェックをして、間隔DとBがそれぞれ規定通りか確認する。また、ヘッド・ベースとスプリング支柱との間 (図5-8のC) にすき間があるか確認する。

### 5-3-4 キュー・モード

1. 録音済みのテープを挿入する。

ポーズ・モードにしてFFボタンまたはREWボタンを押した時にキュー信号が出るかどうか確認する。キュー信号が出ないかまたは信号レベルが極端に低い場合は、半固定抵抗 R546 (図5-6) を調整する。

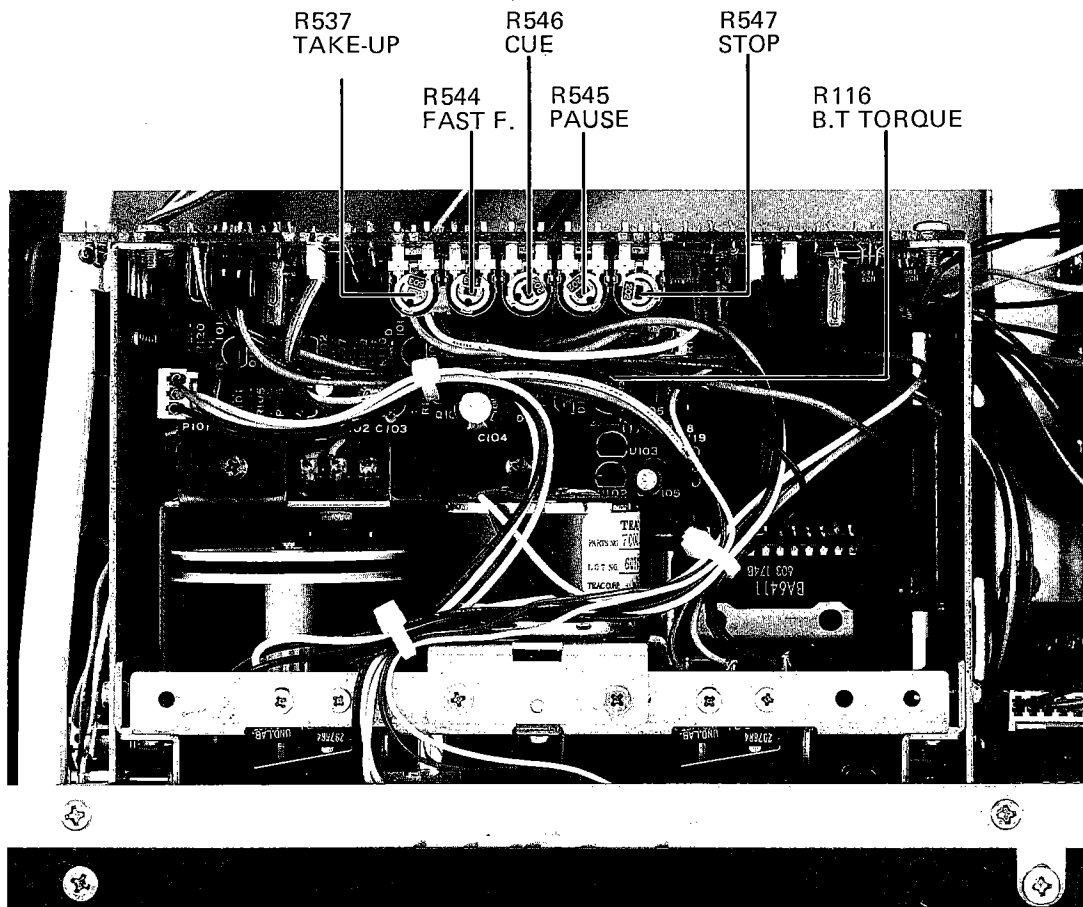

Fig. 5-6

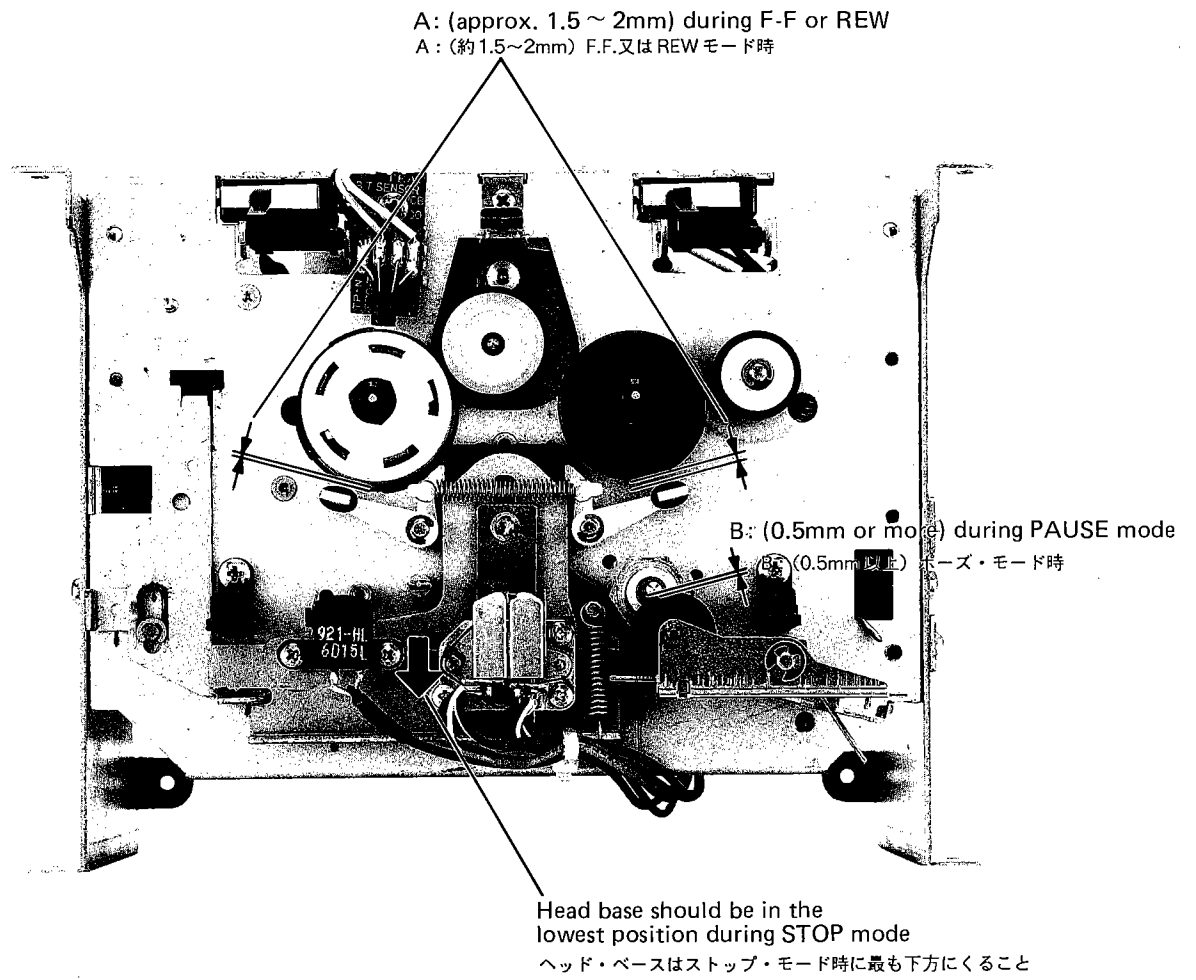

Fig. 5-7

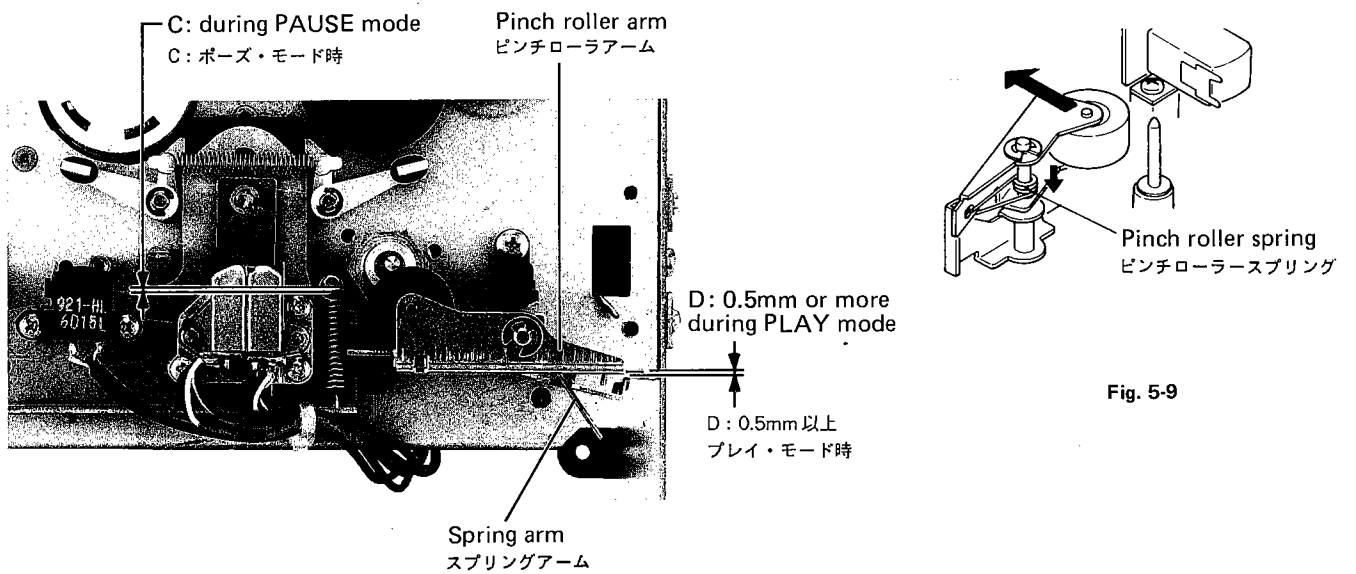

Fig. 5-9

Fig. 5-8



## 5-4 PINCH ROLLER PRESSURE

1. Pushing up the cassette-in sensor arm (refer to Fig. 3-2), activate the play mode. Keep the sensor arm pushed up during measurement.

**Note:** During play operation, make sure there is a clearance of 0.5 mm or more between the pinch roller arm and the spring arm. Refer to Fig. 5-8.

2. Hook a spring scale to the small opening on the pinch roller arm.
3. Pull the scale as shown by arrow until the pinch roller moves away from the capstan shaft by approx. 2 mm, and then allow the pinch roller to just touch the capstan shaft again.
4. Read the scale when the pinch roller just starts to rotate. The reading should be from 350 g to 500 g (12.3 Oz. to 17.6 Oz.).
5. If the pinch roller spring (Fig. 5-9) was replaced for repair, always position the spring around the lower half of the spring shaft as shown in Fig. 5-9.

## 5-5 REEL TORQUE

### 5-5-1 TAKE-UP/BACK TENSION TORQUES

1. Load a cassette torque meter in the cassette holder, and run the deck in play mode. The meter reading should be:

Take-up torque (right reel table): 47 to 53 g-cm  
(0.65 to 0.74 oz-inch)

Back tension torque (left reel table): 9 to 11 g-cm  
(0.13 to 0.15 oz-inch)

2. If the back tension torque is out of limits, adjust the trim pot R116 (Fig. 5-6).

The adjustment should be made about 15 sec. after the reel starts rotation. Read the torque meter for about 5 sec. after completion of the adjustment.

3. If the take-up torque is out of the limits, adjust the trim pot R537 (refer to Fig. 5-6).

4. If the take-up torque is still out of the limits, adjust the torque adjusting ring provided on the right reel table. The torque can be adjusted to three values as shown in Fig. 5-10. Turn the torque adjusting ring with the tab (A), pulling slightly upward, and place the tab on one of three stepped portions having pawls to fix the tab.

5. Repeat steps 2 and 3 until good results are achieved.

**Caution:** In each track measurement, a cassette type torque meter is used. The torque meter should be calibrated with a reference dial type torque meter.

## 5-4 ピンチ・ローラ圧着力

1. カセットイン・センサー・アーム (図3-2参照) を上方に押し、プレイ・モードにする。測定中、センサー・アームは上方に押し続けること。

注意: プレイ・モード中、ピンチ・ローラ・アームとスプリング・アーム間に約0.5mm以上のすき間があるか確認する (図5-8参照)。

2. ピンチ・ローラ・アームの小さい穴にバネ秤を掛ける。
3. ピンチ・ローラがキャプスタン・シャフトから約2mm離れるように秤を矢印の方向に引張った後、ピンチ・ローラが再びキャプスタン・シャフトに接触するように除々に戻す。
4. ピンチ・ローラが回りはじめる時の値を読む。測定値は350～500gの範囲内に入ること。
5. もし修理のためにピンチ・ローラ・スプリング (図5-9) の交換をした時は、必ず図5-9のようにスプリングをスプリング・シャフトの下側に位置させる。

## 5-5 リール・トルク

### 5-5-1 テイクアップ・トルク/バック・テンション・トルク

1. カセット・ホルダーにカセット・トルク・メータを装てん後、プレイ・モードにする。規定値は次の通りです。

テイクアップ・トルク (右リール台): 47～53・cm

バック・テンション・トルク (左リール台): 9～11・cm

2. バックテンション・トルクが規定値から外れている場合は半固定抵抗R116 (図5-6) を調整する。

調整はスタート約15秒たってから調整する。また、そのままの状態 (約5秒) で確認する。

3. もしテイクアップ・トルクが規定値から外れている場合は、半固定抵抗R537 (図5-6参照) を調整する。

4. もしテイクアップ・トルクが更に規定値から外れている場合は、右リール台のトルク調整リングを回して調整する。トルクは図5-10に示すように3段階に調整できる。リール台のマーカのある部分だけ段階部分にツメが設けられているので、調整時にはタブAを持ち上げるようにしてトルク調整リングを回す。

5. 2, 3項を繰り返して最適トルクを求める。

注意: それぞれのトラックはカセットタイプのトルクメータで測定する。測定する前に、標準ダイアル型トルクメータで校正しておく。

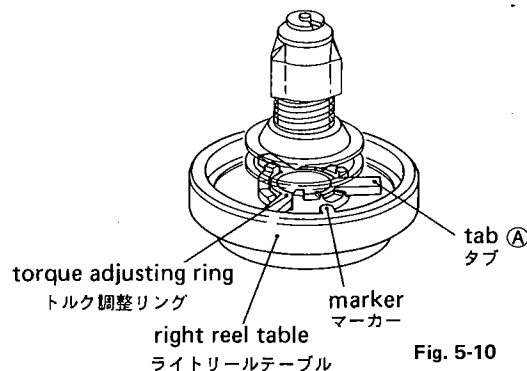

Fig. 5-10

## 5-5-2 F.F./REW TORQUES

1. Load a cassette torque meter in the cassette holder and measure starting torque for both F.F. (fast forward) and REW (rewind) operations with the tape wound close to end or rewound close to beginning, respectively.

The reading should be:

F.F. torque (right reel table): more than 55 g·cm  
(more than 0.76 oz·inch)

REW torque (left reel table): more than 80 g·cm  
(more than 1.1 oz·inch)

## 5-6 TAPE SPEED

1. Connect a frequency counter to either one of OUTPUT jacks. Fig. 5-11.
2. Depress POWER switch to ON.
3. Load a TEAC MTT-111 test tape containing a 3,000 Hz test tone, then leave the deck for at least one minute to warm up the capstan motor.

4. Playback the test tape, and make sure the following values are obtained at the beginning and at the end of the tape. (PITCH CONT SW: OFF)

Deviation: 3,000 Hz  $\pm$ 30 Hz

PITCH CONTROL range: More than  $\pm$ 12% for the speed when (PITCH CONT SW: ON) PITCH CONT is set to off.

5. If the speed is out of the limits, adjust as follows:
  - a) Clean the tape path and check the pinch roller pressure and take-up torque.
  - b) If they are normal, push PITCH CONTROL (off), and reproduce approx. the mid portion of the test tape.
  - c) Adjust the speed trim pot R502 (refer to Fig. 3-1) provided on the rear side of the PITCH CONTROL switch using a small "-" driver with the handle completely insulated from the blade to obtain a 3,000 Hz  $\pm$ 5 Hz reading on the frequency counter.

## 5-5-2 F.F./REDトルク

1. カセット・ホルダにカセット・トルク・メータを装着し、F.F.(早送り)動作の起動トルクをテープの巻終り近くで、またRWD動作の起動トルクをテープの巻始め近くでそれぞれ測定する。規格は次の通りです。

F.F.トルク (右リール台): 55g・cm以上

RWDトルク (左リール台): 80g・cm以上

## 5-6 テープ速度

1. 周波数カウンタをOUTPUTジャックに接続する(図5-11参照)

2. POWERスイッチを押してオンにする。

3. キャプスタン・モータを回転させウォーミングアップするためにTEAC MTT-111テスト・テープを装着して、少くとも一分間そのままにしておく。

4. テスト・テープを再生させ、テープの巻始めと巻終りにて下記の値が得られるか確認する。

偏差: 3,000Hz $\pm$ 30Hz PITCH CONTスイッチ OFF  
ピッチ・コントロール可変範囲 (PITCH CONTスイッチ ON):

PITCH CONT オフ時の速度に対して  
 $\pm$ 12%以上

5. もし速度が範囲から外れている場合は、次の通り調整する。

- a. テープ走行面を清掃して、ピンチ・ローラ圧着力、テイクアップ・トルクをチェックする。
- b. その結果が正常であれば、ピッチ・コントロールをオフにさせ、テスト・テープのテープ巻きの中ほどを再生する。
- c. 周波数カウンタが3,000Hz $\pm$ 5Hzを示すようにピッチ・コントロール・スイッチの裏側にあるスピード半固定抵抗R502(図3-1参照)を回して調整する。調整には柄が刃先から完全に絶縁されている小型マイナス・ドライバを用いること。

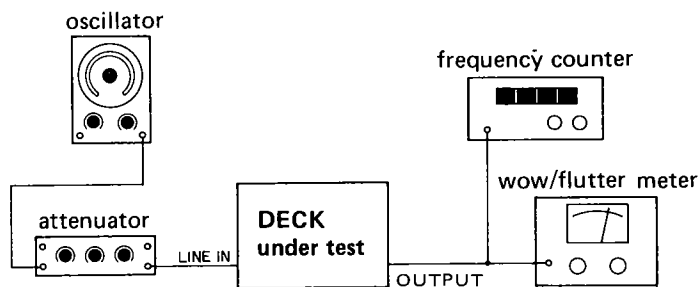

Fig. 5-11

## 5-7 WOW AND FLUTTER

**Note:** These measurements should be made at the beginning, middle and the end of the tape.

1. Connect a wow and flutter meter to the deck as shown in Fig. 5-11.
2. Load and play a TEAC MTT-111 test tape or equivalent.
3. Measure the wow and flutter value.

Specifications:  $\pm 0.08\%$  peak (DIN/IEC/ANSI weighted)  
0.06% (NAB weighted)

## 5-8 CASSETTE HOLDER

1. Adjust the holder guide plate's mounting position so that when the cassette holder in which the cassette tape is inserted is closed, the parallel condition shown in Fig. 5-12 is obtained.

## 5-7 ワウ・フラッタ

注意：テープの巻始め、中間、巻終りでそれぞれ測定します。

1. 図5-11のようにワウ・フラッタ・メータをデッキに接続する。
2. TEAC MTT-111テスト・テープまたは相当品を装てんして再生する。
3. ワウ・フラッタ値を測定する。  
規格：0.06%WRMS（聴感補正）

## 5-8 カセット・ホルダ

1. カセットがそう入されたカセット・ホルダを閉じて、図5-12に示す平行状態が得られるようにホルダ・ガイド板の取付位置を調整する。

Viewed from right side  
右側面図

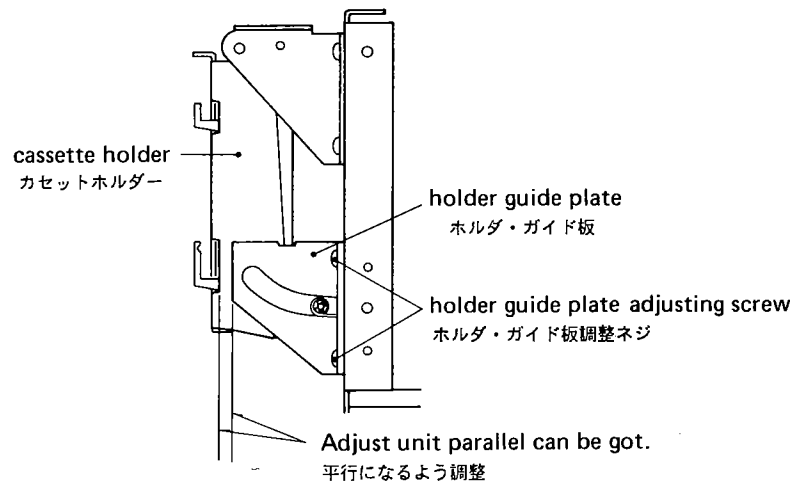

Fig. 5-12

### 5-9 DAMPER ADJUSTMENT

1. Load a C-60 tape and close the cassette holder (with the door cover attached).
2. Turn the air adjusting screw so that when pushing the EJECT button, the cassette holder opens smoothly and completely, taking 0.5 to 1.5 seconds.

### 5-9 ダンパ調整

1. ブランク・テープ (MTT-5511) を装てんして、カセット・ホルダ (ドア付) を閉じる。
2. EJECT 釦を押した時、カセット・ホルダが0.5秒~1.5秒の時間でなめらかにかつ完全に開くように、エア調整ネジを回して調整する。

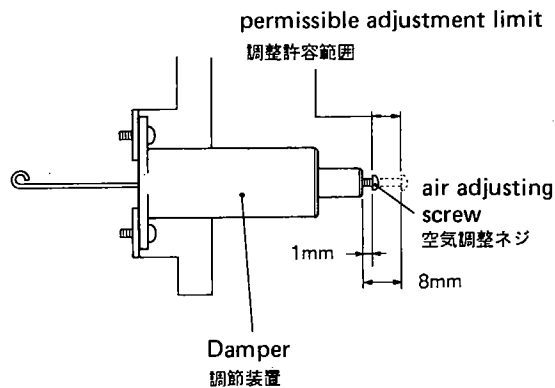

Fig. 5-13

### 5-10 VOLTAGE CONVERSION (FOR GENERAL EXPORT MODELS)

ALWAYS DISCONNECT THE POWER LINE CORD BEFORE MAKING THESE CHANGES.

1. Locate the voltage selector on the rear panel.
2. Using a regular (slot blade) screwdriver, turn the selector until the numerals corresponding the voltage requirements of your area appear.
3. We suggest you label the rear panel with the set AC line voltage.

**Note:** Select 50 Hz or 60 Hz by S501 on Control PCB Ass'y.

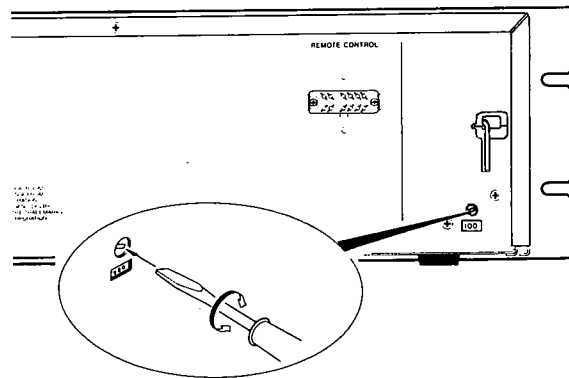
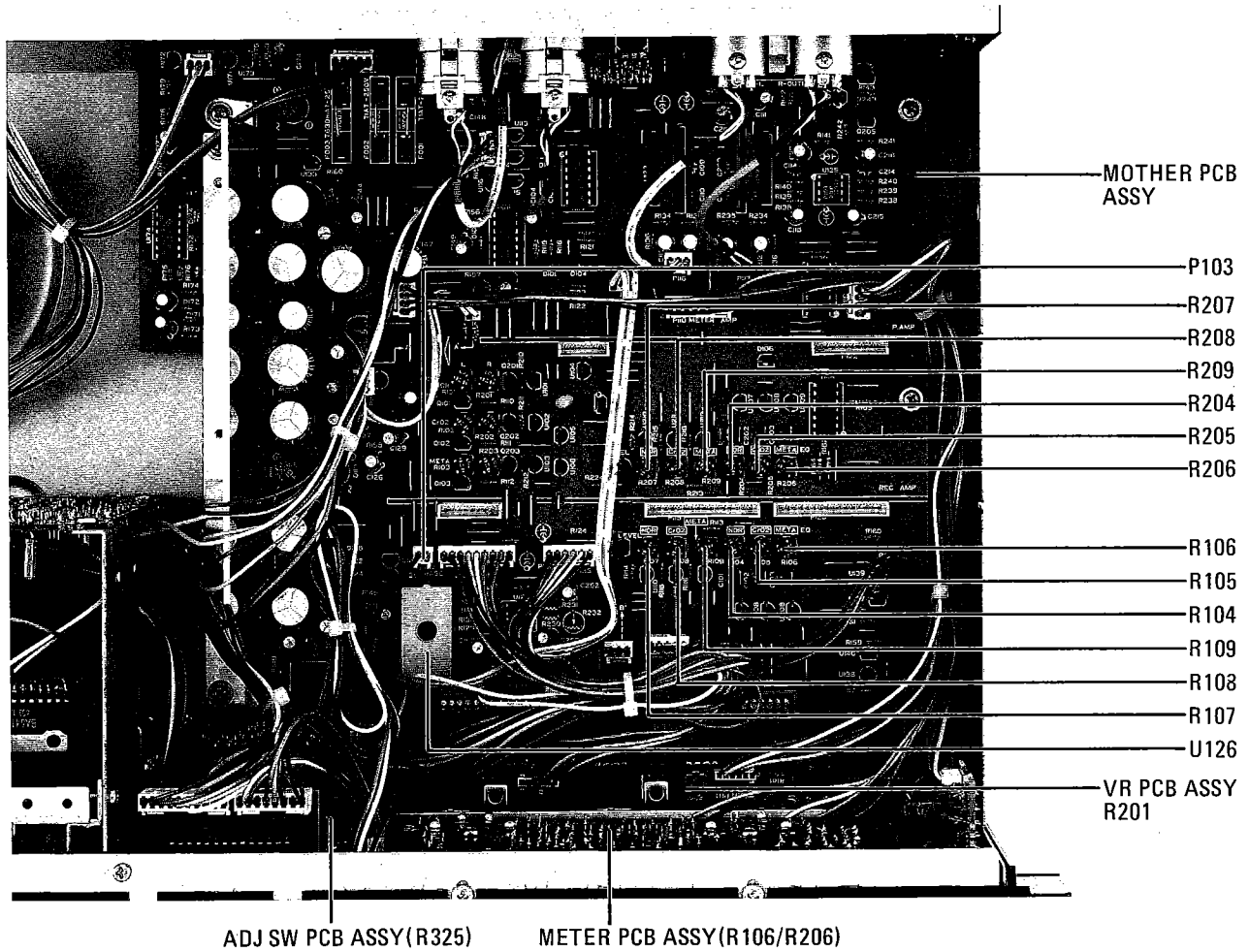

Fig. 5-14

[注] 50Hz/60Hzの切換はコントロールPCB Ass'y上のスイッチS501で行ないます。

## 6. ELECTRICAL CHECKS AND ADJUSTMENTS

### アンプ部のチェックと調整



#### MOTHER PCB ASSY

REFERENCE NUMBER	FUNCTION	REFERENCE NUMBER	FUNCTION
R101/R201	BIAS ADJUSTMENT (NORMAL)	R107/R207	REC LEVEL ADJUSTMENT (NORMAL)
R102/R202	BIAS ADJUSTMENT (CrO <sub>2</sub> )	R108/R208	REC LEVEL ADJUSTMENT (CrO <sub>2</sub> )
R103/R203	BIAS ADJUSTMENT (METAL)	R109/R209	REC LEVEL ADJUSTMENT (METAL)
R104/R204	REC EQ ADJUSTMENT (NORMAL)		
R105/R205	REC EQ ADJUSTMENT (CrO <sub>2</sub> )	U126	BIAS OSC FREQUENCY ADJUSTMENT
R106/R206	REC EQ ADJUSTMENT (METAL)		

#### METER PCB ASSY

REFERENCE NUMBER	FUNCTION
R106/R206	METER CALIBRATION

#### VR PCB ASSY

REFERENCE NUMBER	FUNCTION
R201	OUTPUT LEVEL BALANCE ADJUSTMENT (R-ch)

#### ADJ SW PCB ASSY

REFERENCE NUMBER	FUNCTION
R325	400 Hz/10 KHz LEVEL BALANCE ADJUSTMENT

Fig. 6-1 Adjustment Points

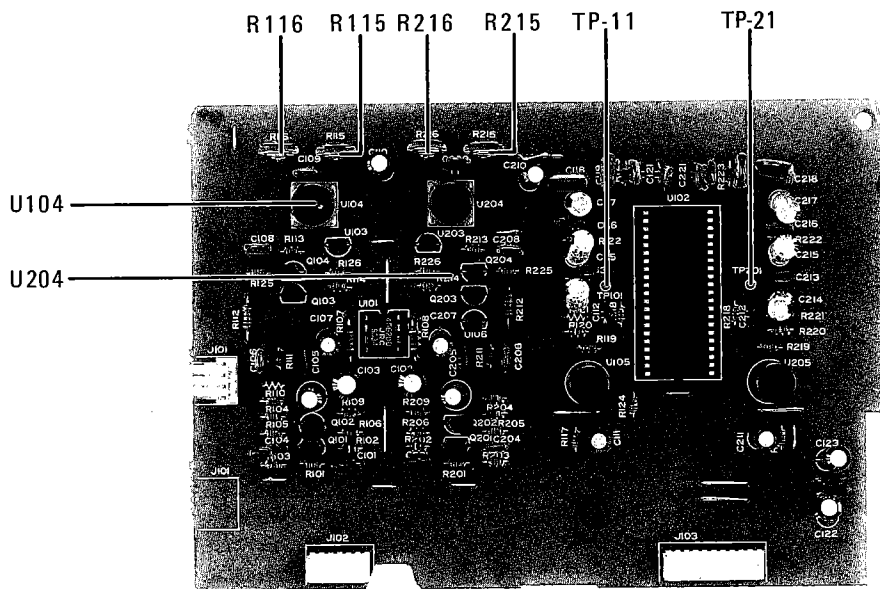

REFERENCE NUMBER	FUNCTION	REFERENCE NUMBER	FUNCTION
R115/R215	DOLBY LEVEL CALIBRATION	U104/U204	BIAS TRAP (REPRO)
R116/R216	REPRO EQ ADJUSTMENT		

Fig. 6-2 Check and Adjustment Points on PLAY AMP P.C.B. ASSY.

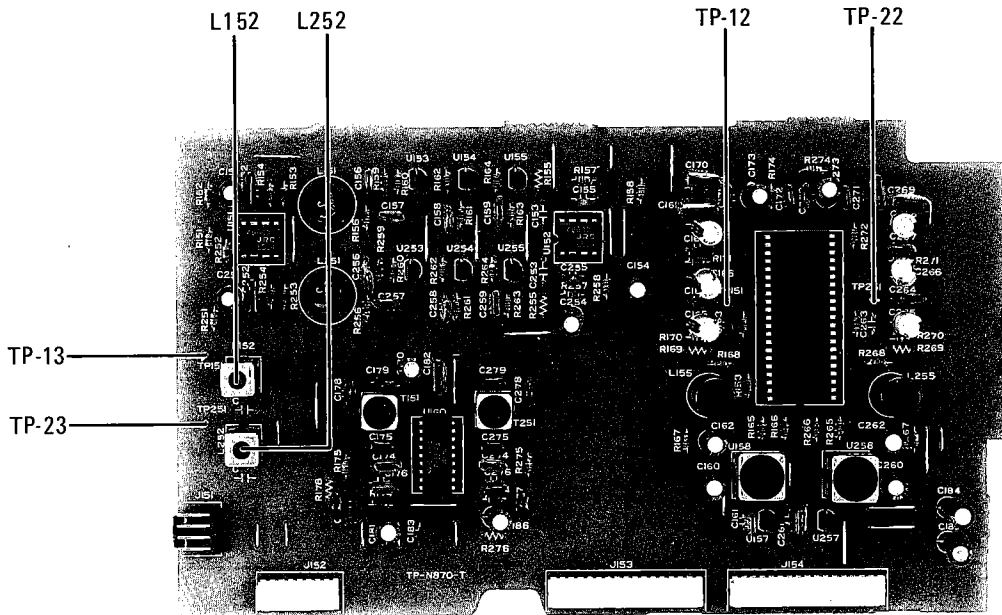

REFERENCE NUMBER	FUNCTION
L152/L252	BIAS TRAP (REC)

Fig. 6-3 Check and Adjustment Points on REC AMP P.C.B. ASSY.

# 6-1. PLAYBACK PERFORMANCE 再生系

## Initial Settings 予備設定

- |                 |          |               |         |
|-----------------|----------|---------------|---------|
| DOLBY NR switch | : OUT    | OUTPUT switch | : REPRO |
| MPX FIL switch  | : OUT    | OSC switch    | : OFF   |
| TAPE switch     | : NORMAL | ADJ switch    | : OFF   |

Mode : PLAY

ITEM 調整項目	SETTING 設定	INPUT SIGNAL 入力信号	ADJUST (or CHECK) 調整箇所	MEASURING POINT, RESULT 測定箇所・調整値
1. REC・PLAY head azimuth 録・再ヘッド アジマス	Connection (接続): Fig. 6-4	MTT-256 10 KHz section	P.B azimuth adj. screws (Fig. 6-4-2)	OUTPUT : Phase between L-ch/R-ch : 0° Hax. output at L-ch & R-CH's L-R間の位相差が0°で且つ両ch 共最大出力
2. Repr output level 再生出力レベル	Connection (接続): Fig. 6-5	MTT-150	R115/R215 (Fig. 6-2)	TP. 11/TP. 21 (Fig. 6-2) : 245 mV
	Connection (接続): Fig. 6-6		OUTPUT CONT.	OUTPUT (RCA pin jack) L-ch : -7 dBV (0.447 mV)
			R201 (Fig. 6-1)	OUTPUT (RCA pin jack) R-ch : -7 dBV (0.447 mV)
			After adjusting, do not move the output cont. (Nominal position) 調整後はOUTPUTつまみを動かさないこと。(規定位置)	
3. Repr frequency responce 再生周波数特性	Connection (接続): Fig. 6-6	MTT-256	R116/R216 (Fig. 6-2)	OUTPUT (RCA pin jack) : Level difference as slight as possi- ble between for 315 Hz and 10 kHz, 315 Hzと10 kHzの出力が同レベルに なるよう調整
			Check	OUTPUT (RCA pin jack) : Specifications 規格: Fig. 6-7

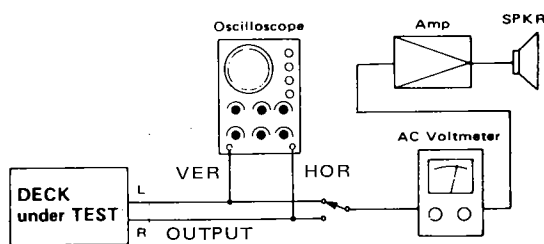

Fig. 6-4-1 Test setup for azimuth check 位相測定接続図

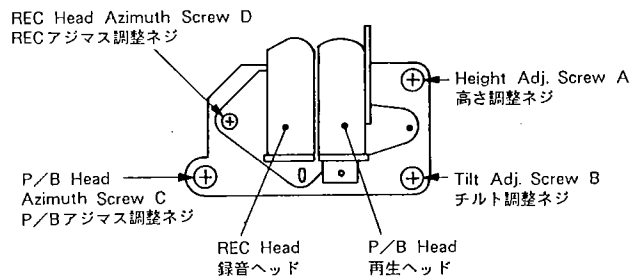

Fig. 6-4-2

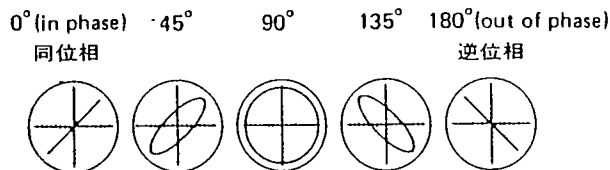

Fig. 6-4-3 Phase Difference  
位相関係図

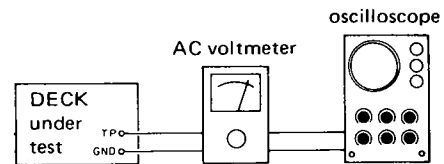

Fig. 6-5 Connections Through Test Points  
テスト・ポイント・チェック時の接続図

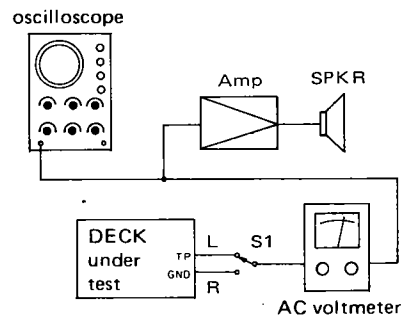

Fig. 6-6 Test setup for output check 出力測定時の接続図

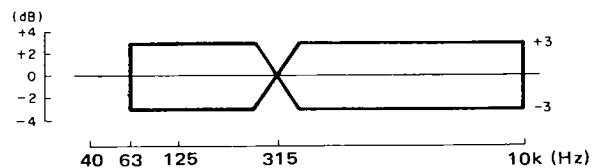

Fig. 6-7 Repr Frequency Response  
再生周波数特性

6-2. MONITOR PERFORMANCE モニター系

Initial Settings 予備設定

- |                 |          |               |         |
|-----------------|----------|---------------|---------|
| DOLBY NR switch | : OUT    | INPUT switch  | : REAR  |
| MPX FIL switch  | : OUT    | OUTPUT switch | : INPUT |
| TAPE switch     | : NORMAL | OSC switch    | : OFF   |
|                 |          | ADJ switch    | : OFF   |

Mode : REC/PAUSE

INPUT SELECT switch(REAR): RCA IN

ITEM 調整項目	SETTING 設定	INPUT SIGNAL 入力信号	ADJUST (or CHECK) 調整箇所	MEASURING POINT, RESULT 測定箇所・調整値
4. Minimum INPUT level 最小入力レベル	Connection (接続): Fig. 6-8 INPUT cont.: Max.	INPUT (Rear, RCA) 400 Hz / -18 dBV (126 mV)	Check	OUTPUT (RCA pin jack): -10 dBV ± 3 dB (224 m ~ 447 mV)
5. Nominal INPUT level 規定入力レベル	Same as above 同上	INPUT (Rear, RCA) 400 Hz / -10 dBV (316 mV)	INPUT cont. L, R	OUTPUT (RCA pin jack): -10 dBV ± 3 dB (224 m ~ 447 mV)
After adjusting, do not move the INPUT controls. (Nominal position) 調整後はINPUTつまみを動かさないこと。(規定位置)				
6. Meter level メータ・レベル	Same as above 同上	Same as above 同上	R106/R206 (Fig. 6-1)	VU meter indication: 0 VU
7. Internal osc. 内部発振器	Same as above 同上 OSC switch → ON	No signal 無信号	Check	VU meter indication: 0 VU ± 2 VU
	Same as above 同上 400 Hz / 10 kHz switch: 400 Hz ↔ 10 kHz	No signal 無信号	R325 (Fig. 6-1)	VU meter indication: Adjust for minimum level difference between 400Hz and 10kHz switch positions. スイッチを切替えたときメータ指示変化が 最小になるよう調整する。
8. PHONES output level PHONES出力レベル	Connection (接続): Fig. 6-9	INPUT (Rear, RCA): 400 Hz / -10 dBV (316 mV)	Check	PHONES each channel 各チャンネルで: More than -1 dBV (0.891 V) -1 dBV (0.891 V) 以上
9. Bias osc frequency	Connection (接続): Fig. 6-10 Record mode	No signal 無信号	U126 (Fig. 6-1)	CONNECTOR P103 (pin2) 100 kHz (Fig. 6-1)
10. Bias trap バイアス・ トラップ	Connection (接続): Fig. 6-5 REC/PAUSE mode	Same as above 同上	L152/1252 (Fig. 6-3)	TP. 13/TP. 23 (Fig. 6-3): Minimum bias leakage バイアス漏れ最小
11. Front input	Connection (接続): Fig. 6-8 REC/PAUSE mode	INPUT (Front, RCA): 400 Hz / -10 dBV (316 mV)	Check	OUTPUT (RCA pin jack): -10 dBV ± 1 dB (0.355 V ~ 0.282 V)

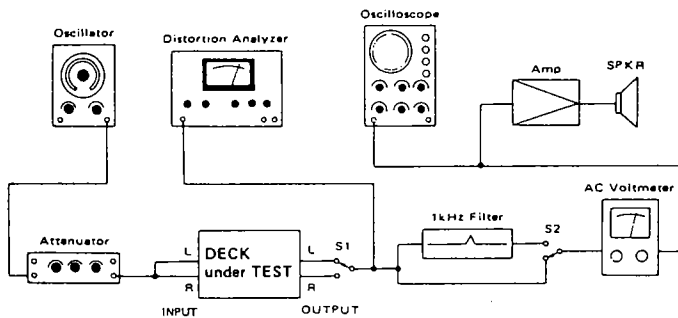

Fig. 6-8 Basic Test Setup  
基本測定接続図

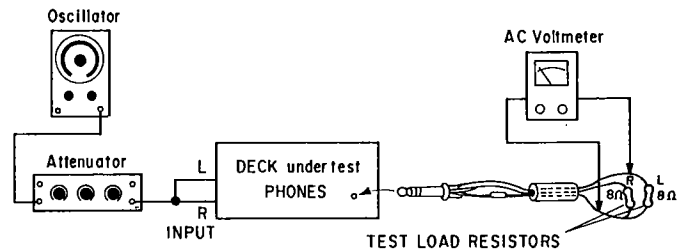

Fig. 6-9 Test setup for PHONES check  
ホーン出力測定接続図

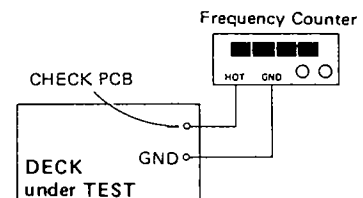

Fig. 6-10 Setup for Bias Osc. Frequency Adjustment  
バイアス発振周波数調整用接続図



## 6-3. RECORDING PERFORMANCE 録音系

## Initial Settings 予備設定

DOLBY NR switch	: OUT	OUTPUT switch	: REPRO
MPX FIL switch	: OUT	OSC switch	: OFF
TAPE switch	: NORMAL	ADJ switch	: OFF
INPUT switch	: REAR	INPUT SELECT switch(REAR):	RCA IN

## Mode : RECORD

ITEM 調整項目	SETTING 設定	INPUT SIGNAL 入力信号	ADJUST (or CHECK) 調整箇所	MEASURING POINT, RESULT 測定箇所・調整値
12. Bias-1 バイアス-1	Connection (接続): Fig. 6-8	INPUT (REAR, RCA) 400 Hz, 10 kHz/ -40 dBV (10.0 mV)	R101/R201 (Fig. 6-1)	OUTPUT (RCA pin jack): Equal output level (record then Re- produce) between for 400 Hz and 10 kHz. 400 Hz と 10 kHz の録再出力が等しく なること。
13. Rec azimuth-1 録音アジマス-1	Connection (接続): Fig. 6-4	INPUT (REAR, RCA) 10 kHz/-40 dBV (10.0 mV)	REC azimuth adj. screw (Fig. 6-4-2)	OUTPUT (RCA pin jack) L & R: Phase between L-ch & R-ch: 90° or less L-R間の位相差: 90° 以内
14. Rec bias 録音バイアス	Connection (接続): Fig. 6-8	INPUT (REAR, RCA) 6.3 kHz/-40 dBV (10.0 mV)  Adjusting point: Fig. 6-1	Turn bias adjust pot (s) CCW and adjust the pot CW carefully. Set the pot at position which develops a value shown below after rec/repro output passes a peak level. 調整するボリュームを一旦左に回しておいてから徐々に右に 回す。録再出力がピークを過ぎて下記のレベルだけ下がる点に セットする。	
	Test tape: MTT-5511 NORMAL		R101/R201	OUTPUT (RCA pin jack): 4 dB
	Test tape: MTT-5561 CrO2		R102/R202	OUTPUT (RCA pin jack): 3 dB
	Test tape: MTT-5571 METAL		R103/R203	OUTPUT (RCA pin jack): 1 dB
15. Rec level-1 録音レベル-1	Connection (接続): Fig. 6-8 Test tape: MTT-5511 NORMAL	INPUT (REAR, RCA) 400 Hz/-10 dBV (316 mV)  Adjusting point: Fig. 6-1	R107/R207	OUTPUT (RCA pin jack): -10 dBV (316 mV)
	Same as above 同上 Test tape: MTT-5561 CrO2		R108/R208	
	Same as above 同上 Test tape: MTT-5571 METAL		R109/R209	
16. Rec EQ 録音イコライザ	Connection (接続): Fig. 6-8 Test tape: MTT-5511 NORMAL	INPUT (REAR, RCA) 400 Hz, 10 kHz/ -10 dBV (316 mV)  Adjusting point: Fig. 6-1	R104/R204	OUTPUT (RCA pin jack): Adjust to obtain same output level at 10kHz and 400Hz. 10 kHz 出力が 400 Hz 出力と同じに なるよう調整する。
	Same as above 同上 Test tape: MTT-5561 CrO2		R105/R205	
	Same as above 同上 Test tape: MTT-5571 METAL		R106/R206	
17. Rec azimuth-2 録音アジマス-2	Connection (接続): Fig. 6-4	INPUT (REAR, RCA) 400 Hz, 10 kHz/ (10.0 mV)	Check	OUTPUT (RCA pin jack): Phase difference between simultaneous and different time REC/PLAY. 同時録再, 異時録再の位相差 400 Hz: 45° 以内 10 kHz: 90° 以内
18. Rec level-2 録音レベル-2	Connection (接続): Fig. 6-8 Test tapes: same item 15.	INPUT (REAR, RCA) 400 Hz/-10 dBV (316 mV)	Check	OUTPUT (RCA pin jack): All tapes. DOLBY NR IN/OUT -12 dBV to -8 dBV (251 mV to 398 mV)
19. Total harmonic distortion 総合歪率	Connection (接続): Fig. 6-8 Test tapes: same as above DOLBY NR: OUT	INPUT (REAR, RCA) 400 Hz/-10 dBV (316 mV)	Check	OUTPUT (RCA pin jack): 2.0% or less for all tapes. 各テープで2.0%以下

ITEM 調整項目	SETTING 設定	INPUT SIGNAL 入力信号	ADJUST (or CHECK) 調整個所	MEASURING POINT, RESULT 測定個所・調整値
20. Overall frequency 録再周波数特性	Connection (接続): Fig. 6-8 DOLBY NR: OUT and IN	INPUT (REAR, RCA) 400 Hz~16 kHz/ -40 dBV (10.0 mV)	Check	OUTPUT (RCA pin jack): Specification: Fig. 6-12
21. Bias leakage バイアス漏れ	Connection (接続): Fig. 6-8	No signal 無信号	U104/U204 (Fig. 6-2)	OUTPUT (RCA pin jack): Minimum bias leakage バイアス漏れ最小 Spec.: -40 dBV (10.0 mV) or less
22. Manual CAL マニュアル CAL	No connection 接続なし OSC switch: ON (400 Hz) ADJ switch: ON	No signal 無信号	BIAS cont.	VU meter indication: max.
	400 Hz/10 kHz sw: 10kHz		LEVEL cont.	VU meter indication: 0 VU
	Connection (接続): Fig. 6-8 OSC switch: OFF DOLBY NR: OUT Test tapes: same as item 16	INPUT (REAR, RCA) 400 Hz~16 kHz/ -40 dBV (10.0 mV)	Check	OUTPUT (RCA pin jack): Specification: Fig. 6-12
23. Overall S/N ratio 総合S/N	Connection (接続): Fig. 6-8 DOLBY NR: OUT Test tapes: same as item 16	No signal 無信号	Check	OUTPUT (RCA pin jack): NORMAL: 41 dB min CrO2: 42 dB min METAL: 42 dB min Reference level 基準レベル: 400 Hz/-10 dBV (316 mV)
24. Erase efficiency 消去効果	Same as above 1 kHz filter connect 1 kHz フィルター接続 Test tape: MTT-5571	INPUT (REAR, RCA) 1 kHz/0 dBV (1.0 V)	Check	OUTPUT (RCA pin jack): 65 dB min.
	Record a 1 kHz signal rewind tape to mid point of recorded portion. Erase the recorded portion with no input signal find the difference between the 1 kHz portion and the "no-signal" portion. 1 kHz 信号を録音後、中間までテープを巻き戻して一部を消去する。未消去部分と消去部分の1 kHz 出力レベル差を測定			
25. Channel separation	Same as above	INPUT (REAR, RCA): L-ch: 1 kHz/ -10 dBV (316 mV) R-ch: no signal	Check	OUTPUT (RCA pin jack): 30 dB min.
	Find the difference between the 1 kHz recorded portion (L-ch) and the "no signal" portion (R-ch). 1 kHz 録音部分 (L-ch) と無信号録音部分 (R-ch) の再生出力レベルの差を測定する。			
26. Adjacent track crosstalk トラック間クロストーク	Same as above but a 1 kHz filter is not connected 同上 1 kHz フィルターは使用せず	INPUT (REAR, RCA): L-ch: no signal R-ch: 125 Hz/ -10 dBV (316 mV)	Check	OUTPUT (RCA pin jack): 40 dB min.
	Record a 125 Hz signal on R-ch and note output level. Then invert tape and play R-ch track. Check leakage level against the output reference of previously recorded portion. R-ch に 125 Hz を録音し、その再生出力を基準レベルとする。 次にテープを反転し、再生したときの R-ch 出力レベルとの差を測定する。			

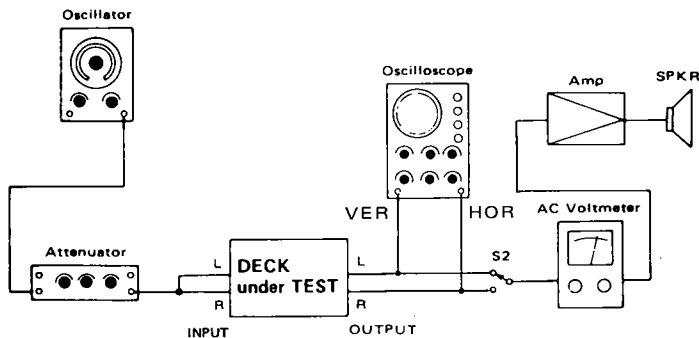

Fig. 6-11 Test setup for azimuth check  
位相測定接続図

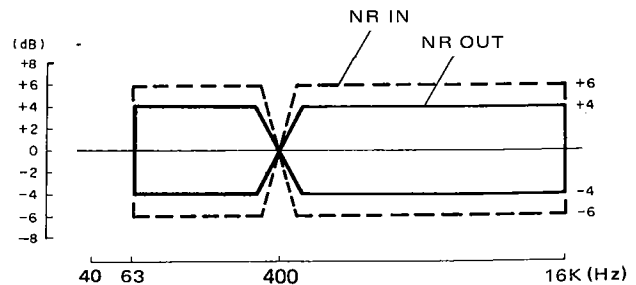

Fig. 6-12 Overall Frequency Response  
総合周波数特性

## 7. EXPLODED VIEWS AND PARTS LISTS

### 分解図とパーツ・リスト

#### NOTES

As regards the resistors and capacitors, refer to the circuit diagrams and the PCB ass'y drawings included in this brochure.

- \* Parts marked with \* require longer delivery time.
- \* Resistor values are in ohms (K = 1,000 ohms, M = 1,000,000 ohms).
- \* All capacitor values are in microfarads (p = picofarads).
- \*  $\Delta$  Parts marked with this sign are safety critical components. They must always be replaced with identical components — refer to the TEAC Parts List and ensure exact replacement.
- \* 0 dB is referenced to 1V in this manual unless otherwise specified.
- \* PC boards shown viewed from foil side.
- \* Parts not shown in the parts lists or parts, though listed, having no parts numbers are not general "ready-to-supply" parts.
- Dolby Noise Reduction System manufactured under license from Dolby Laboratories Licensing Corporation.  
"Dolby" and the double-D symbol are trademarks of Dolby Laboratories Licensing Corporation.

#### 注意

標準器の抵抗：コンデンサーは省略してあります。回路図及び基板図を参照してください。

1. プリント基板図はパターン面が示されています。
2. \*印の部品は納期が若干かかります。あらかじめご了承ください。
3.  $\Delta$ 印は安全規格重要部品です。交換するときは必ずティアック指定の部品を使用して下さい。
4. レベルは0dB=1Vを基準にしています。
5. コンデンサの単位はuF, p=pF (1uF=1,000,000pF)
6. 製品が改善されているために、製品と回路図が一部異っている場合があります。
7. リストされていない部品は原則としてサービス供給部品として取扱っていません。

※ノイズリダクションシステムは、ドルビー研究所からの実施権に基づき製造されています。

※ドルビー及び  $\Delta$  は、ドルビー研究所の登録商標です。

EXPLODE VIEW-1

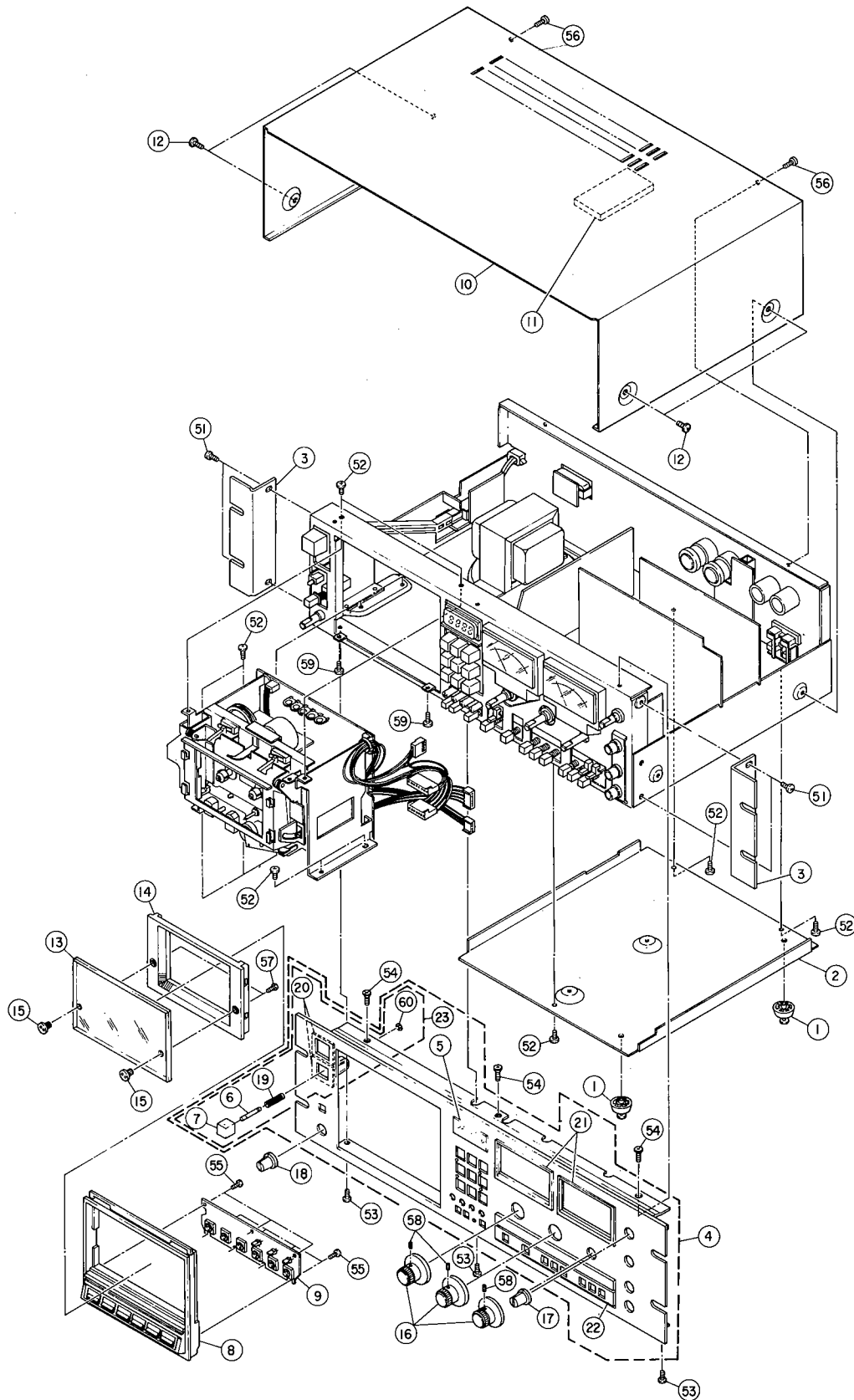

## EXPLODED VIEW-1

Parts marked with \* require longer delivery time.

REF.NO.	PART NO.	DESCRIPTION	REMARKS
1- 1	*5730003300	FOOT,FF-008(P4X6)	
1- 2	*5800826100	COVER, BOTTOM	
1- 3	*5800826200	ANGLE, RACK	
1- 4	*5800933900	FRONT PANEL B ASSY	
1- 5	*5800690400	WINDOW,COUNTER	
1- 6	*5800472201	ROD,EJECT	
1- 7	5800827800	BUTTON,POWER	
1- 8	*5800827201	ESCUSHION ASSY	
1- 9	*5200121010	OPERATION SW PCB ASSY	
1-10	*5800826600	BONNET	
1-11	*5800933801	PAD, PCB	
1-12	*5800612400	SCREW,M3X8 BLK	
1-13	5800471701	COVER,CASSETTE	
1-14	5800122500	COVER,CASSETTE;2	
1-15	*5800116800	BUSHING	
1-16	5543027100	KNOB,VR	
1-17	5800756100	KNOB A ASSY(14)	
1-18	5800757300	KNOB C ASSY(14)	
1-19	*5800471500	SPRING, EFECT: A	
1-20	*5800894900	ESCUSHION, BUTTON	
1-21	*5800825400	ESCUSHION, METER	
1-22	*5800934000	ESCUSHION, B	
1-23	*5800828200	BUTTON, ESCUSHION ASSY	
1-51	*5783003008	SCREW, S TITE PAN 3X8	
1-52	*5783003005	SCREW, S TITE PAN 3X5	
1-53	*5783033006	SCREW, S TITE BIND 3X6	
1-54	*5783043006	SCREW, S TITE FLAT 3X6	
1-55	*5781112006	SCREW, TAPPING M2X6	
1-56	*5783613008	SCREW, C TITE 3X8 (BLK NI)	
1-57	*5781112606	SCREW, TAPPING 2.6X6	
1-58	*5782003004	SCREW, HEX M3X4	
1-59	*5783622608	SCREW, FLANGED M2.6X8	
1-60	*5786002500	E RING, E-25	

## INCLUDED ACCESORIES

REF.NO.	PART NO.	DESCRIPTION	REMARKS
	5700091700	OWNER'S MANUAL[J]	
	5700091800	OWNER'S MANUAL[US, C, A, GE, UK]	
	5700091900	OWNER'S MANUAL[E]	

[US]:U.S.A. [E]:EUROPE [UK]:U.K. [C]:CANADA [A]:AUSTRALIA [GE]:GENERAL EXPORT [J]:JAPAN

EXPLODE VIEW-2

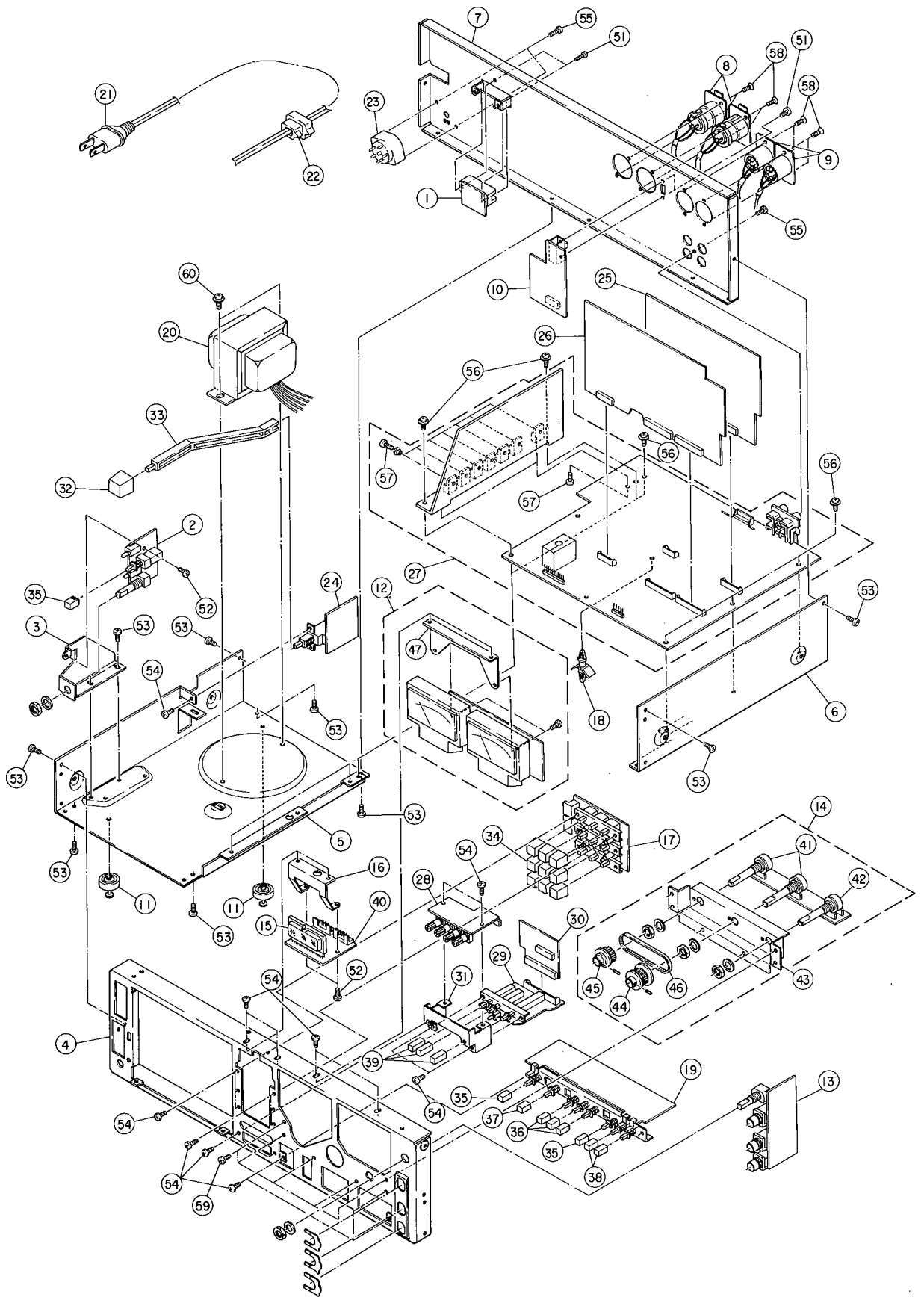

## EXPLODED VIEW-2

Parts marked with \* require longer delivery time.

REF.NO.	PART NO.	DESCRIPTION	REMARKS
2- 1	*5200195600	REMOTE CONNECTOR PCB ASSY	
2- 2	*5200195910	PITCH CONT PCB ASSY	
2- 3	*5800825901	PLATE P.C VR	
2- 4	*5800826702	CHASSIS, FRONT	
2- 5	*5800826300	CHASSIS, L	
2- 6	*5800826001	CHASSIS, R	
2- 7	*5800826500	PANEL(B), REAR	
2- 8	*5334027300	CONNECTOR,CANNON XLB-3-31	
2- 9	*5334027200	CONNECTOR,CANNON XLB-3-32	
2-10	*5200218800	BAL AMP PCB ASSY	
2-11	*5730003300	FOOT, FF-008(P4X6)	
2-12	*5200218300	METER PCB ASSY	
2-13	*5200218400	H. PHONE PCB ASSY	
2-14	*5200218900	VR PCB ASSY	
2-15	5312000100	ELECTRONIC COUNTER; FL4028-06	
2-16	*5800824400	PLATE, COUNTER	
2-17	*5200218600	COUNTER SW PCB ASSY	
2-18	*5787035400	SUPPORT, PCB LCB-4L	
2-19	*5200218500	MONITOR SW PCB ASSY	
2-20	△*5320043700	TRANS., POWER [J]	
	△*5320043800	TRANS., POWER [US, C]	
	△*5320043900	TRANS., POWER [GE]	
	△*5320044000	TRANS., POWER [E, UK, A]	
2-21	△*5128027000	CORD,AC [J]	
	△*5350010700	CORD,AC [US, C, GE]	
	△*5350008200	CORD,AC [E]	
	△*5128047000	CORD,AC [UK]	
	△*5350008300	CORD,AC [A]	
2-22	△*5317003400	BUSHING	
2-23	△*5302101700	SW.,VOLTAGE SELECT; FS907G[GE]	
2-24	*5200218700	POWER SW PCB ASSY [J, US, C, GE]	
	*5200218710	POWER SW PCB ASSY [E, UK, A]	
2-25	*5200218100	PLAY AMP PCB ASSY	
2-26	*5200218200	REC AMP PCB ASSY	
2-27	*5200218000	MOTHER PCB ASSY [J, US, C, GE]	
	*5200218010	MOTHER PCB ASSY [E, UK, A]	
2-28	*5200219000	ADJ VR PCB ASSY	
2-29	*5200219100	ADJ SW PCB ASSY	
2-30	*5200219200	JOINT PCB ASSY	
2-31	*5800932900	PLATE, SW	
2-32	5800173100	BUTTON,POWER	
2-33	*5800825600	BAR, LINKING	
2-34	5800827901	BUTTON,P-N07-A	
2-35	5800727501	BUTTON A, PUSH	
2-36	5800727601	BUTTON B, PUSH	
2-37	5800727701	BUTTON B, PUSH	
2-38	5800727901	BUTTON E, PUSH	
2-39	5800541600	KNOB A, ASSIGN	
2-40	*5620130500	COUNTER ASSY	
2-41	5282016000	VR, 10KA(R103, R203)	
2-42	5282411600	VR, 10KA X 2(R102)	
2-43	*5800824600	BRACKET, VR	
2-44	*5800933000	GEAR A ASSY	
2-45	*5800933500	GEAR B ASSY	
2-46	*5800933600	BELT, TIMING	
2-47	*5800824500	PLATE, METER	

Continued on page 33

[US]:U.S.A. [E]:EUROPE [UK]:U.K. [C]:CANADA [A]:AUSTRALIA [GE]:GENERAL EXPORT [J]:JAPAN

EXPLODE VIEW-3

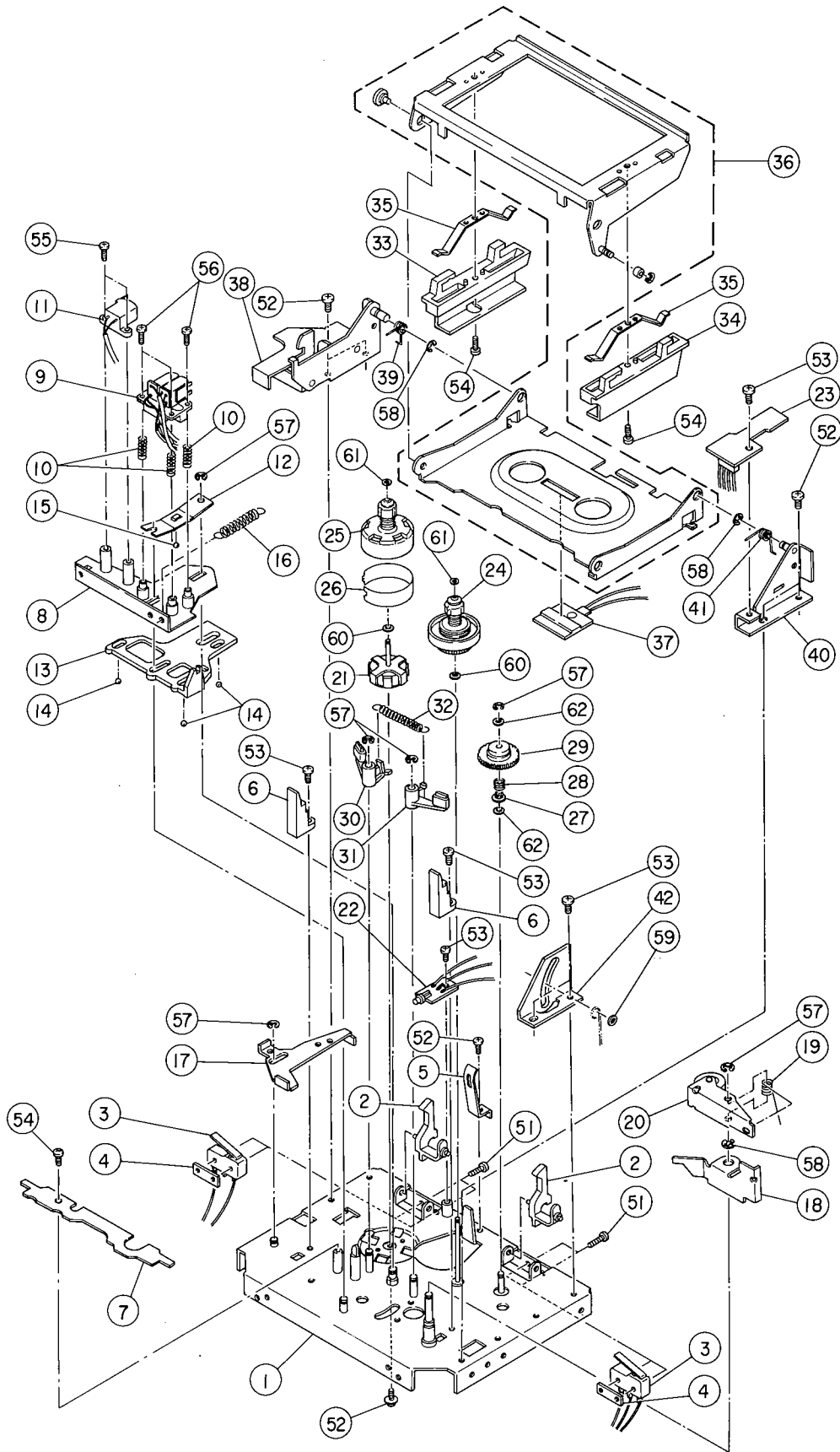



## EXPLODED VIEW-3

Parts marked with \* require longer delivery time.

REF.NO.	PART NO.	DESCRIPTION	REMARKS
3- 1	*5800930600	MECHANISM CHASSIS ASSY	
3- 2	*5800117301	ARM,SENSOR	
3- 3	5301455300	SW.,MICRO SS-5GL	
3- 4	*5554447000	PLATE, SWITCH	
3- 5	*5800115002	SPRING, CASSETTE PRESS	
3- 6	*5800117400	GUIDE, CASSETTE	
3- 7	*5800942900	COVER(B), HEAD	
3- 8	*5800930901	HEAD BASE SUB ASSY	
3- 9	5800931400	HEAD ASSY	
3-10	5800931300	SPRING, HEAD	
3-11	5378904300	HEAD, ERASE	
3-12	*5800114900	SPG.,BASE PLATE, PRESS	
3-13	*5800122804	SLIDER	
3-14	*5540056000	STEEL BALL 30	
3-15	*5540055000	STEEL BALL 20	
3-16	*5800304100	SPRING,BASE ARM	
3-17	*5800119200	STOPPER	
3-18	*5800276201	ARM, SPRING	
3-19	*5800276100	SPG.,P.ROLLER	
3-20	*5800891200	PINCH ROLLER ASSY	
3-21	*5800932000	COIL SHAFT ASSY	
3-22	*5200219400	B.T SENSOR PCB ASSY	
3-23	*5200195500	SENER PCB ASSY	
3-24	5800108701	REEL TABLE ASSY; R	
3-25	5800932600	REEL TABLE ASSY: L	
3-26	*5800932800	RING, HISS	
3-27	*5800159100	HOLDER, SPRING	
3-28	5800124300	SPRING, TENTION	
3-29	5800158800	GEAR ASSY,COUNTER; A	
3-30	*(5534282000	MAGNET)	
3-30	*5800131601	BRAKE ARM(L) ASSY	
3-31	*5800131701	BRAKE ARM(R) ASSY	
3-32	5800114800	SPRING, BRAKE	
3-33	*5800109600	HOLDER, L	
3-34	*5800122100	HOLDER, R	
3-35	*5800115402	SPRING, PRESS, HALF	
3-36	*5800891001	CASSETTE HOLDER SUB ASSY	
3-37	5225015100	LED,SLF301C	
3-38	*5800824700	HOLDER PLATE L ASSY	
3-39	*5800115500	SPRING, HOLDER;L	
3-40	*5800159202	HOLDER PLATE(R) ASSY	
3-41	5800115600	SPRING, HOLDER;R	
3-42	*5800119000	GUIDE PLATE,HOLDER	
3-51	*5780002010	SCREW, BIND M2X10	
3-52	*5783002605	SCREW, S TITE PAN 2.6X5	
3-53	*5783032606	SCREW, S TITE 2.6X6	
3-54	*5780022004	SCREW, BIND M2X4	
3-55	*5780002006	SCREW, BIND M2X6	
3-56	*5780002008	SCREW, M2X8	
3-57	*5786002000	E RING, E-2	
3-58	*5786003000	E RING, E-3	
3-59	*5786331500	POLYSLIDER, 1.5X4X0.5T CUT	
3-60	*5785301100	POLYSLIDER 1.5X4X0.25T	
3-61	*5785331100	POLYSLIDER, 1.2X3.6X0.5T CUT	
3-62	*5785303000	POLYSLIDER, 3.2X5.5X0.25T	

EXPLODE VIEW-4

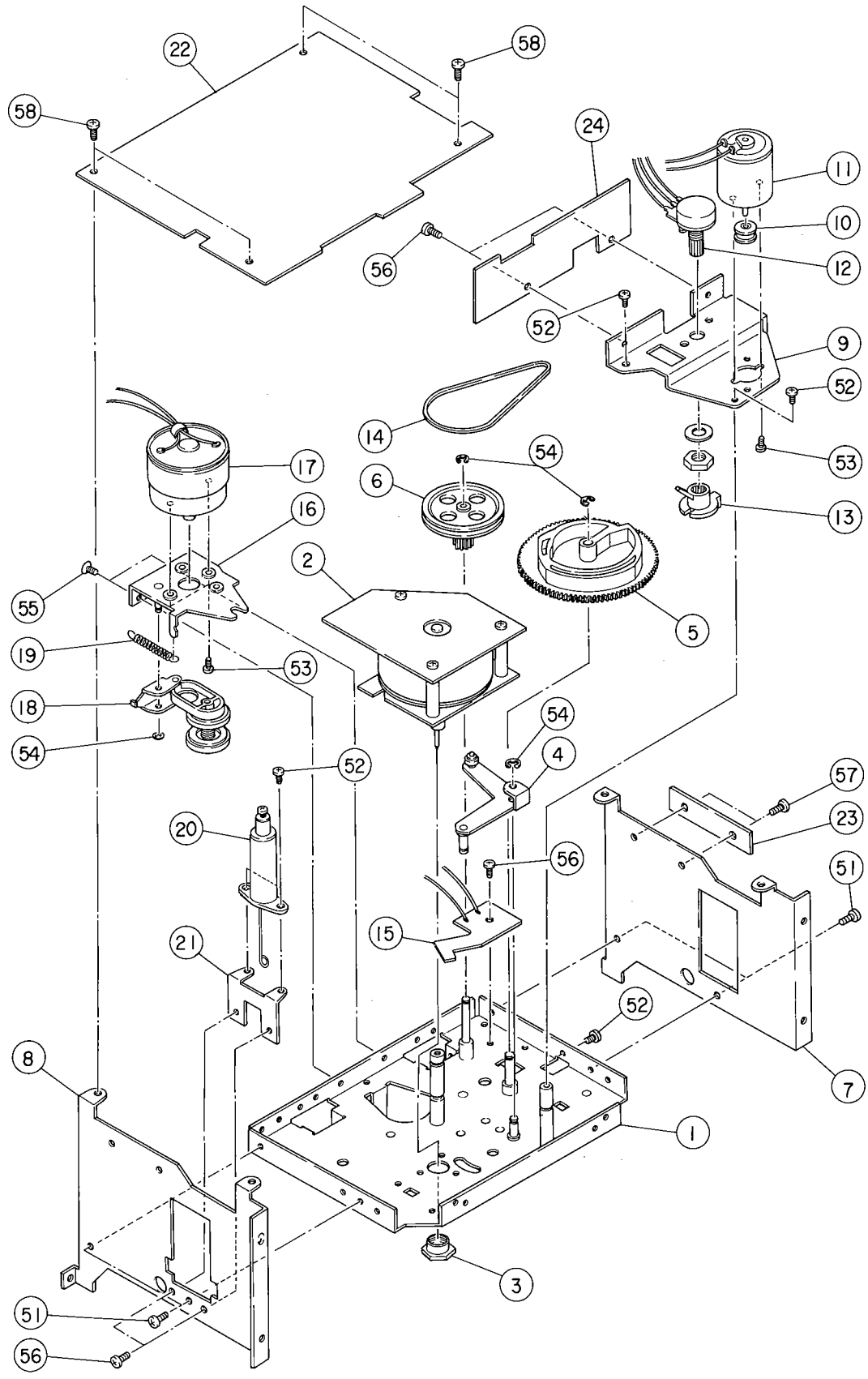

## EXPLODED VIEW-4

Parts marked with \* require longer delivery time.

REF.NO.	PART NO.	DESCRIPTION	REMARKS
4- 1	*5800930600	MECH CHASSIS ASSY	
4- 2	5370007500	MOTOR, DC CAPSTAN	
4- 3	*5800239200	NUT, MOTOR HOLDER	
4- 4	*5800938100	BASE ARM ASSY	
4- 5	5800122700	CAM, CONTROL	
4- 6	5800117200	PULLEY, REDUCTION	
4- 7	*5800825701	PLATE(L), MECHANISM	
4- 8	*5800825801	PLATE(R), MECHANISM	
4- 9	*5800122200	PLATE, HOLDER, MOTOR	
4-10	5800123300	PULLEY, V	
4-11	5370001400	MOTOR, DC, CONTROL	
4-12	5282009600	VR., 10KB	
4-13	*5800116700	JOINT	
4-14	5800106800	BELT, CONTROL	
4-15	*5210219500	B. T. JOINT PCB	
4-16	*5800121801	BRACKET, SUB ASSY, MOTOR	
4-17	5370001200	DC REEL MOTOR ASSY	
4-18	5800107802	IDLER ASSY	
4-19	5800115800	SPRING, IDLER ARM	
4-20	5800131802	DAMPER ASSY	
4-21	*5800941200	BRACKET, DAMPER	
4-22	*5200195410	CONTROL PCB ASSY	
4-23	*5800833900	PLATE, PRESSURE	
4-24	*5200219300	B.T CONT PCB ASSY	
4-51	*5783003005	SCREW, S TITE 3X5	
4-52	*5783002606	SCREW, S TITE 2.6X6	
4-53	*5780002603	SCREW, BIND M2.6X3	
4-54	*5786002000	E RING, E-2	
4-55	*5783042605	SCREW, FLAT S TITE 2.6X5	
4-56	*5783032605	SCREW, S TITE BIND 2.6X5	
4-57	*5780003008	SCREW, BIND M3X8	
4-58	*5780003005	SCREW, BIND M3X5	

Continued from page 29

## EXPLODED VIEW-2

REF.NO.	PART NO.	DESCRIPTION	REMARKS
2-51	*5783002608	SCREW, PAN S TITE 3X8	
2-52	*5780002605	SCREW, BIND M2.6X5	
2-53	*5783003005	SCREW, PAN S TITE 3X5	
2-54	*5780003005	SCREW, BIND M3X5	
2-55	*5783603008	SCREW, P TITE 3X8	
2-56	*5783623008	SCREW, FLANGED M3.0X8	
2-57	*5780003006	SCREW, BIND M3X6	
2-58	*5783653006	SCREW, S TITE FLAT 3X6(NI)	
2-59	*5780003003	SCREW, BIND M3X3	
2-60	*5783074006	SCREW, FLANGED S TITE 4X6	

# 8. PC BOARDS AND PARTS LISTS

## 基板図とパーツ・リスト

CONTROL PCB ASSY

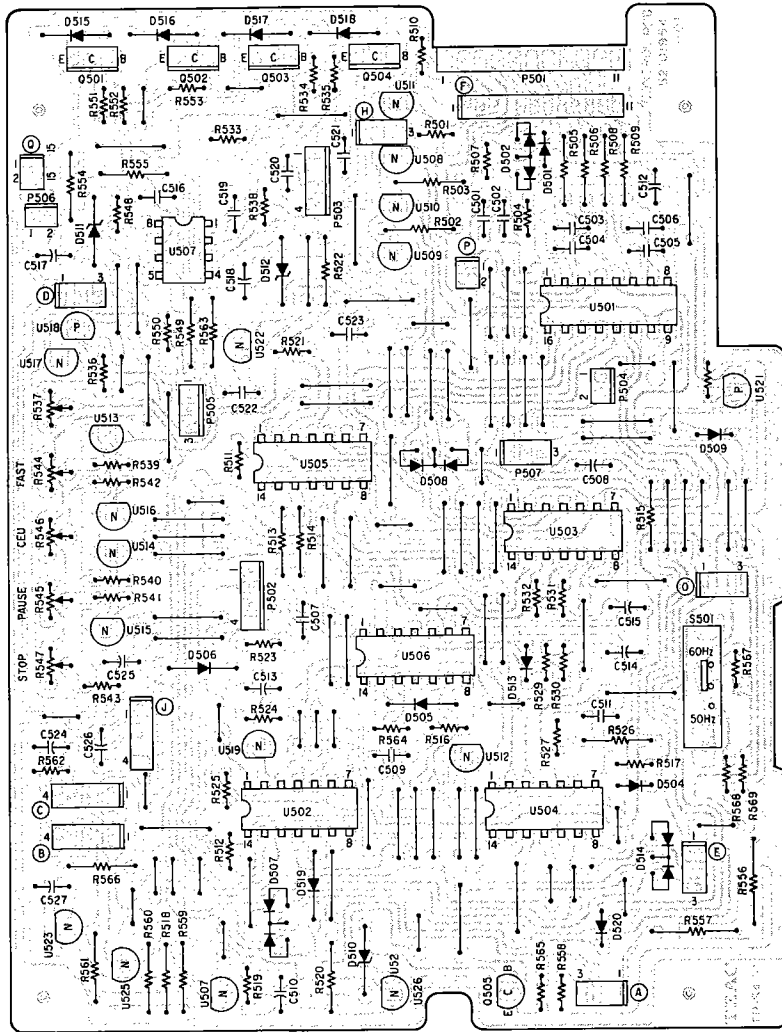

PITCH CONTROL PCB ASSY

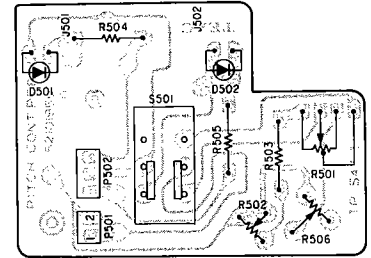

DIGITAL TRANSISTOR

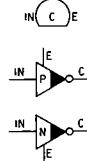

SENSOR PCB ASSY

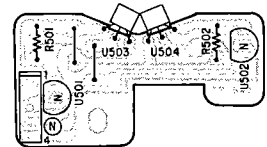

OPERATION SW PCB ASSY

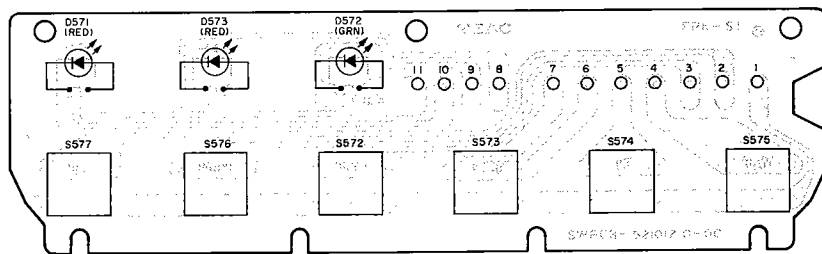

REMOTE CONNECTOR PCB ASSY

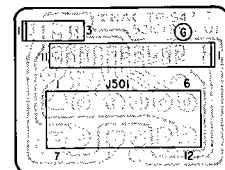

REC AMPL PCB ASSY

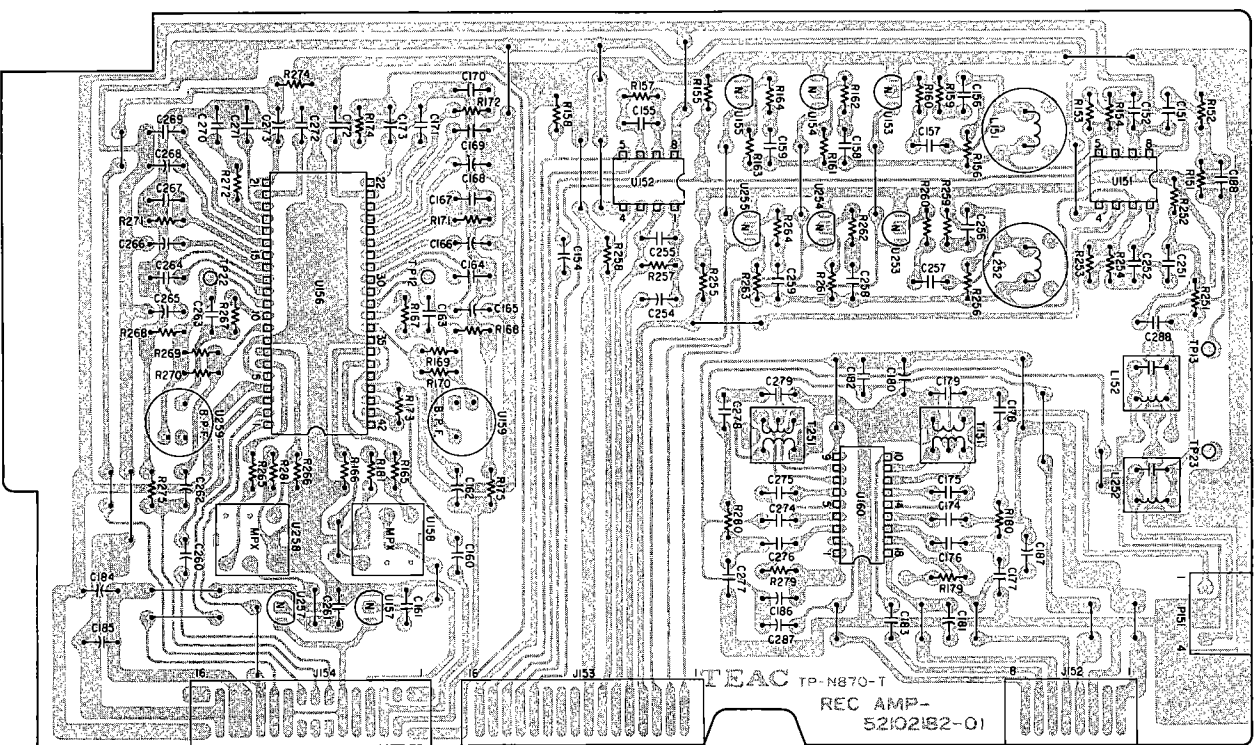

PLAY AMPL PCB ASSY

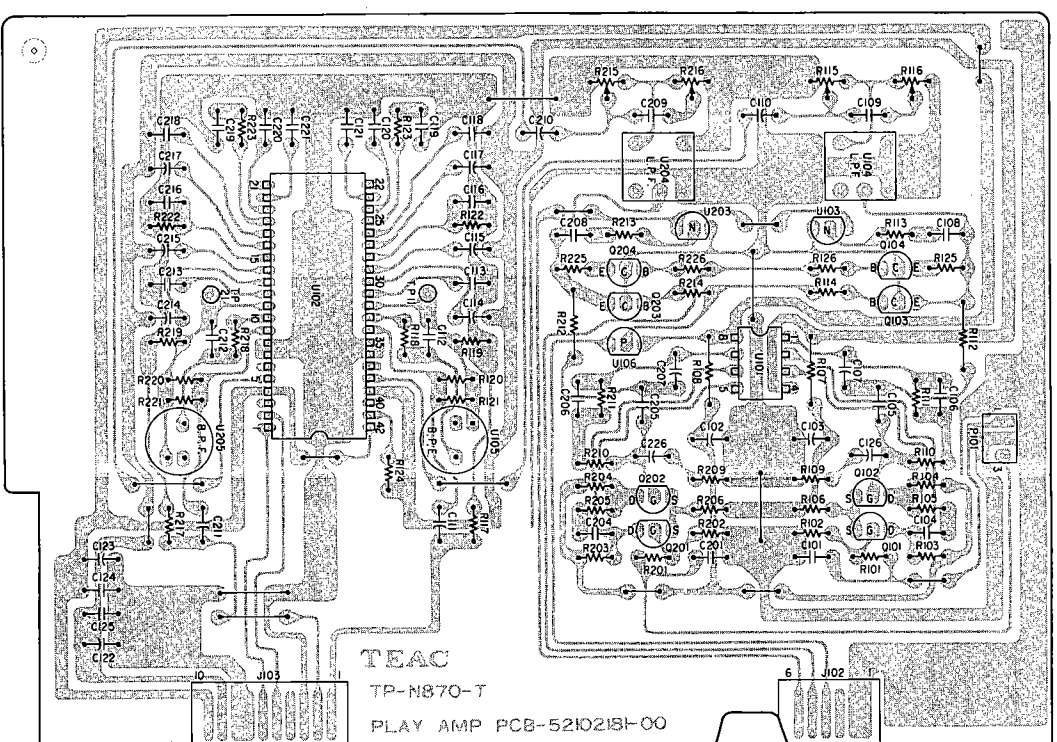

B.T. CONTROL PCB ASSY

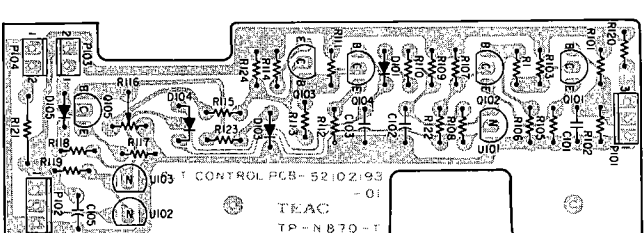

JOINT PCB ASSY

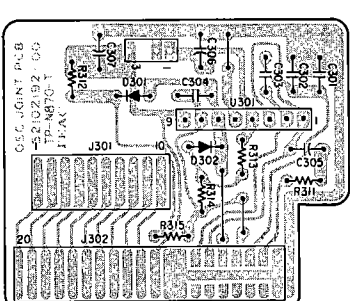

ADJUSTMENT SW PCB ASSY

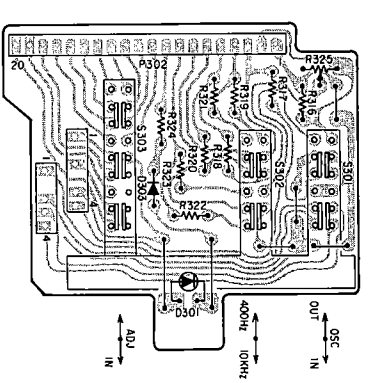

COUNTER SW PCB ASSY

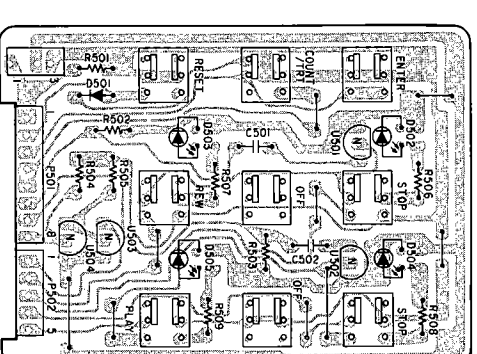

ADJUSTMENT VR PCB ASSY

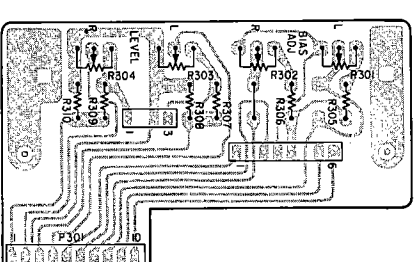

B.T. JOINT PCB



B.T. SENSOR PCB ASSY

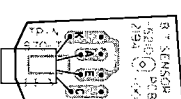

DIGITAL TRANSISTOR

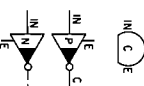

MOTHER PCB ASSY

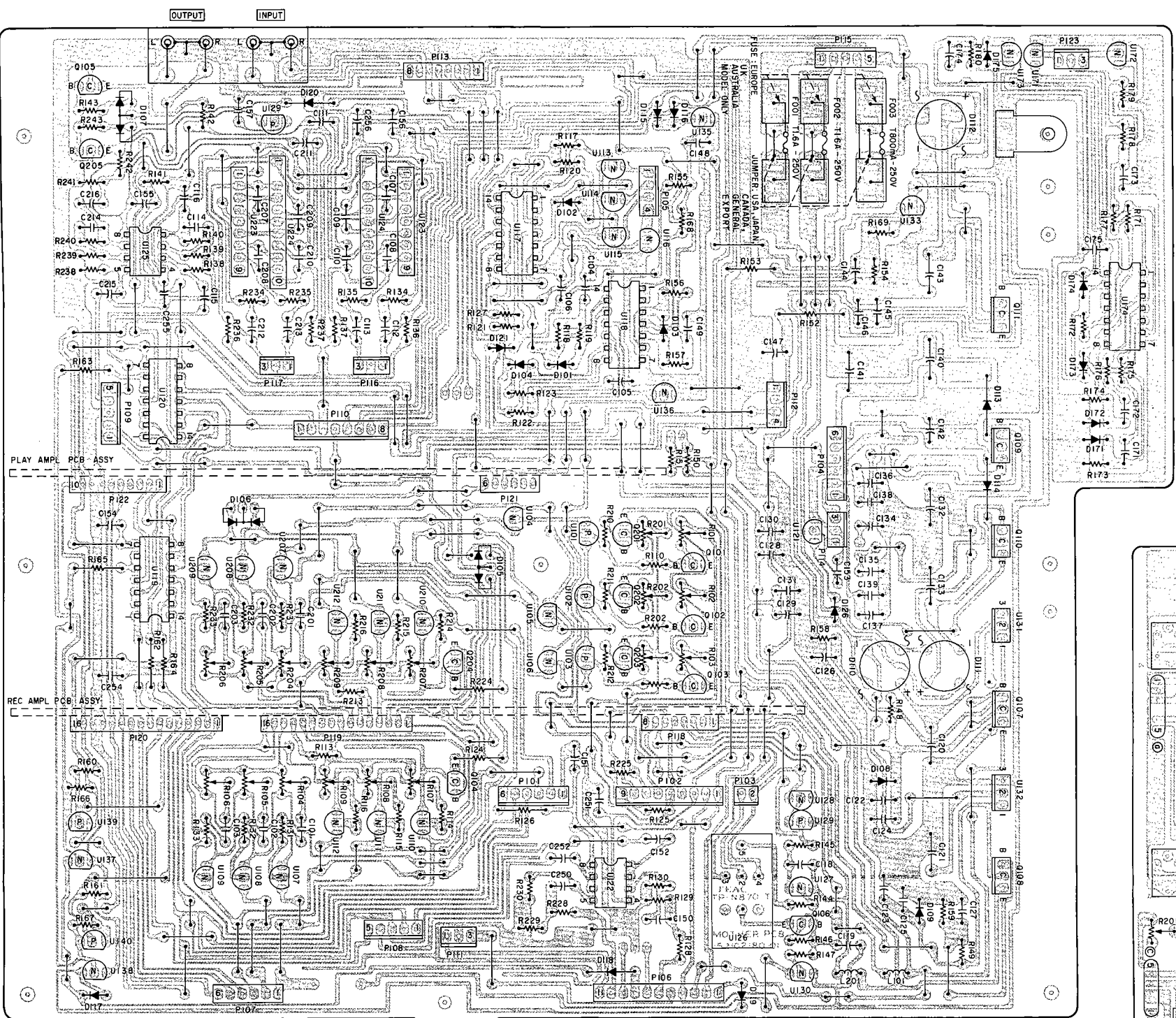

VR PCB ASSY

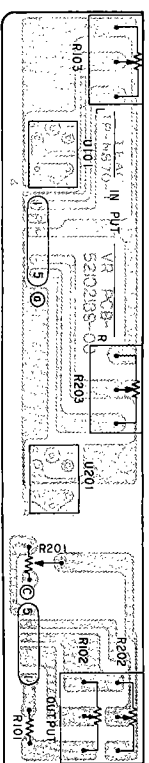

METER PCB ASSY

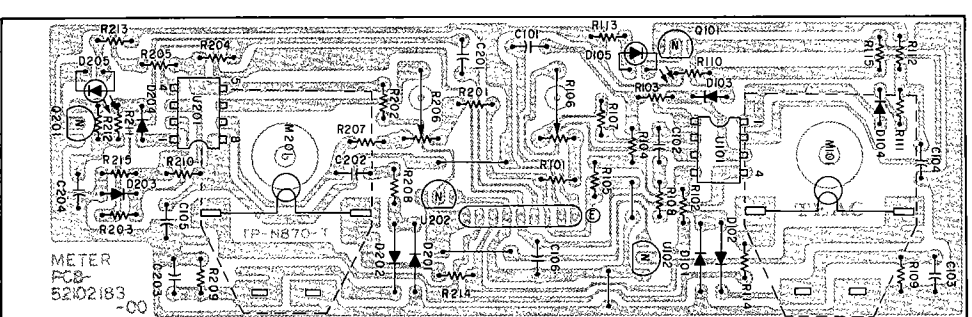

MONITOR SWITCH PCB ASSY

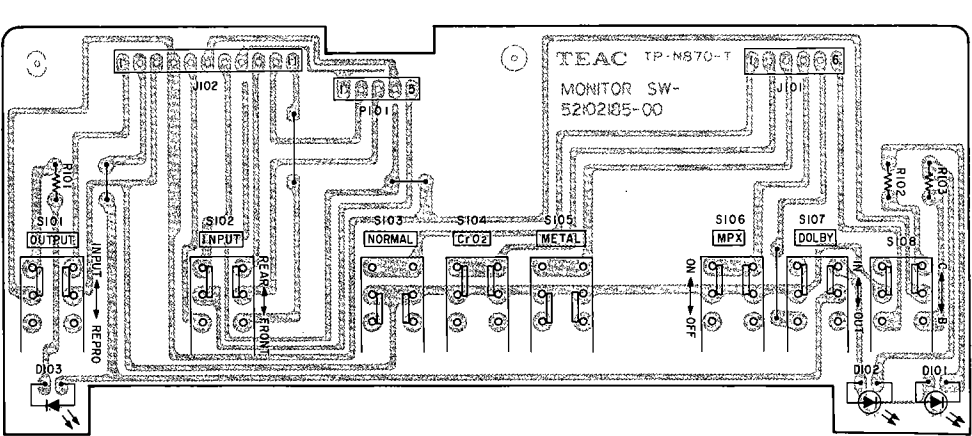

DIGITAL TRANSISTOR

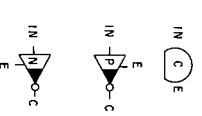

HEADPHONE PCB ASSY

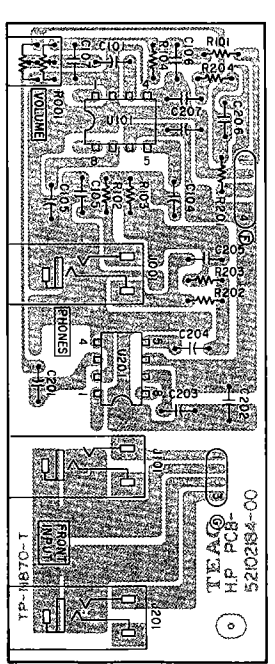

BAL. AMPL PCB ASSY

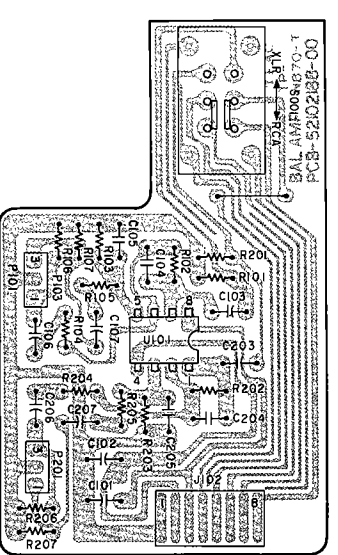

POWER SW PCB ASSY

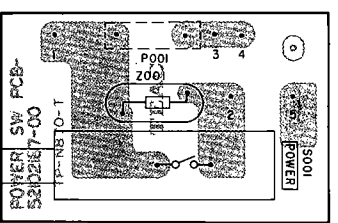

## CONTROL PCB ASSY

REF.NO.	PART NO.	DESCRIPTION
	*5200195410	CONTROL PCB ASSY
	*5210195400	CONTROL PCB
D501	5224015020	DIODE,1SS133T-77
D502	5224015120	DIODE,MC911
D504	5224015020	DIODE,1SS133T-77
D505	5224012920	DIODE,1S2473
D506	5224012920	DIODE,1S2473
D507	5224015220	DIODE,MC921
D508	5224015220	DIODE,MC921
D509	5224015020	DIODE,1SS133T-77
D510	5224540901	DIODE,ZENER RD6.2EB2 FR
D511	5224543101	DIODE,ZENER RD12EB2 FR
D512	5224543101	DIODE,ZENER RD12EB2 FR
D513	5224015020	DIODE,1SS133T-77
D514	5224015220	DIODE,MC921
D515	5143089000	DIODE,W03C
D516	5143089000	DIODE,W03C
D517	5143089000	DIODE,W03C
D518	5143089000	DIODE,W03C
D519	5224012920	DIODE,1S2473
D520	5224015020	DIODE,1SS133T-77
P501	5336213100	CON.,PLUG 5089-11A
P502	5336126400	CON.,PLUG WHT
P503	5336137400	CON.,PLUG 8263-0412
P504	5336126200	CON.,PLUG WHT
P505	5336126300	CON.,PLUG WHT
P506	5336137200	CON.,PLUG BLK
P507	5336135200	CON.,PLUG RED
Q501	5230781400	SI.TR.2SC3421(0) 10 120
Q502	5230019300	TR.,2SA1358(0) 10 120
Q503	5230781400	SI.TR.2SC3421(0) 10 120
Q504	5230019300	TR.,2SA1358(0) 10 120
Q505	5230779520	SI.TR.2SC1815GR 0.4 80
R537	5150156000	R.,TRIMMER 50KB
R544	5150154000	R.,TRIMMER 10KB
R545	5150152000	R.,TRIMMER 2KB 8MM
R546	5150152000	R.,TRIMMER 2KB 8MM
R547	5150152000	R.,TRIMMER 2KB 8MM
R554	△ 5183590000	R.,CARBON INCOMBUST.330
R555	△ 5183590000	R.,CARBON INCOMBUST.330
R556	△ 5185692000	R.,CARBON INCOMBUST.150
R557	△ 5185692000	R.,CARBON INCOMBUST.150
S501	5300913800	SW.,SLIDE 1-2 S SSU11
U501	5220020400	IC.,BA843,
U502	5220019100	IC.,TC4011BP,
U503	5220019000	IC.,TC4001BP,
U504	5220016100	IC.,HD14013BP,
U505	5220020200	IC.,TC4030BP,
U506	5220017200	IC.,HD14069UBP,
U507	5220418800	IC.,M5218P
U508	5232252520	TR.,DIGITAL RT1N241S
U509	5232252520	TR.,DIGITAL RT1N241S
U510	5232252520	TR.,DIGITAL RT1N241S
U511	5232252520	TR.,DIGITAL RT1N241S
U512	5232252520	TR.,DIGITAL RT1N241S

U513	5232252520	TR.,DIGITAL RT1N241S
U514	5232252520	TR.,DIGITAL RT1N241S
U515	5232252520	TR.,DIGITAL RT1N241S
U516	5232252520	TR.,DIGITAL RT1N241S
U517	5232252520	TR.,DIGITAL RT1N241S
U518	5232252620	TR.,DIGITAL RT1P241S
U519	5232252520	TR.,DIGITAL RT1N241S
U521	5232252620	TR.,DIGITAL RT1P241S
U523	5232252520	TR.,DIGITAL RT1N241S
U525	5232252520	TR.,DIGITAL RT1N241S
U526	5232252520	TR.,DIGITAL RT1N241S
U527	5232252520	TR.,DIGITAL RT1N241S

## OPERATION SW PCB ASSY

REF.NO.	PART NO.	DESCRIPTION
	*5200121010	OPERATION SW PCB ASSY
	*5210121001	OPERATION SW PCB
	5302101400	SW.,TACT KHJ10905
	5225010100	LED,SLP-155B RED
	5225010200	LED,SLP-255B GRN

## SENSOR PCB ASSY

REF.NO.	PART NO.	DESCRIPTION
	*5200195500	SENSOR PCB ASSY
	*5210195500	SENSOR, PCB
U501	5232252520	TR.,DIGITAL RT1N241S
U502	5232252520	TR.,DIGITAL RT1N241S
U503	5228700100	IC, DN6838
U504	5228700100	IC, DN6838

## REMOTE CONNECTOR PCB ASSY

REF.NO.	PART NO.	DESCRIPTION
	*5200195600	REMOTE CON., PCB ASSY
	*5210195601	REMOTE CONNECTOR PCB
J501	5334010100	SOCKET,12P CONN

## PITCH CONT PCB ASSY

REF.NO.	PART NO.	DESCRIPTION
	*5200195910	PITCH CONT PCB ASSY
	*5210195900	PITCH CONT PCB
D501	5225006900	LED,PR3432S RED
D502	5225014400	LED,PG3432SY GRN
J501	5122373000	CON.,SOCKET 3024-2AH
J502	5122373000	CON.,SOCKET 3024-2AH
P501	5336128200	CON.,PLUG WHT
P502	5336128300	CON.,PLUG WHT
R501	5282016700	R.,TRIMMER 1S1UVR 100KB
R504	5181474000	R.,CARBON 4700HM J FT
R505	5181474000	R.,CARBON 4700HM J FT

Parts marked with \* require longer delivery time.

## REC AMP PCB ASSY

REF.NO.	PART NO.	DESCRIPTION
	*5200218200	REC AMP PCB ASSY
	*5210218200	REC AMP PCB
J152	5336277800	CON., SOCKET 5513-08APB
J153 J154	5336278600	CON., SOCKET 5513-16APB
L151 L251	5286008700	COIL, CHOKE 8.2MH
L152 L252	5286000200	COIL, TRAP 100KHZ
P151	5336139400	CON., PLUG 8263-0411 RED
T151 T251	5286025700	COIL, STEP UP
TP12 TP22	5544750000	PIN, COMBINATION
TP13 TP23	5544750000	PIN, COMBINATION
U151	5220414300	IC., NJM4560
U152	5220414300	IC., NJM4560
U153 U253	5232252520	TR., DIGITAL RT1N241S
U154 U254	5232252520	TR., DIGITAL RT1N241S
U155 U255	5232252520	TR., DIGITAL RT1N241S
U156	5220427000	IC., CX20187,
U157 U257	5232252520	TR., DIGITAL RT1N241S
U158 U258	5292805600	FILTER, LOWPASS MPX
U159 U259	5292806000	FILTER, L.P 19.8KHZ
U160	5220430400	IC., UPC1297CA

## PLAY AMP PCB ASSY

REF.NO.	PART NO.	DESCRIPTION
	*5200218100	PLAY AMP PCB ASSY
	*5210218100	PLAY AMP PCB
J102	5336277600	CON., SOCKET 5513-06APB
J103	5336278000	CON., SOCKET 5513-06APB
P101	5336128300	CON., PLUG 8263-0311 WHT
Q101 Q201	5145103000	FET, 2SK-68A-M 0.25 150
Q102 Q202	5145103000	FET, 2SK-68A-M 0.25 150
Q103 Q203	5230775000	SI. TR. 2SC2878-B 0.4 30
Q104 Q204	5230780920	SI. TR. 2SC2603F 0.3 200
R107 R108	5183590000	R., INCOMBUST. 30 OHM FR
R115 R215	5150154000	R., TRIMMER 10KB
R116 R216	5150156000	R., TRIMMER, 50KB
TP11 TP21	5544750000	PIN, COMBINATION
U101	5220412500	IC., NJM4562
U102	5220427000	IC., CX20187,
U103 U203	5232252520	TR., DIGITAL RT1N241S
U104 U204	5292805700	FILTER, LOWP. 100KHZ
U105 U205	5292806000	FILTER, L.P 19.8KHZ
U106	5232252620	TR., DIGITAL RT1P241S

## B.T CONT PCB ASSY

REF.NO.	PART NO.	DESCRIPTION
	*5200219300	B.T CONT PCB ASSY
	*5210219300	B.T CONT PCB
D101	5224015020	DIODE, 1SS133T-77
D103	5224015020	DIODE, 1SS133T-77
D104	5224015220	DIODE, MC921
D105	5224015020	DIODE, 1SS133T-77
P101	5336126300	CONNECTOR, PLUG WHT
P102	5336135300	CONNECTOR, PLUG RED
P103	5336126200	CONNECTOR, PLUG WHT
P104	5336137200	CONNECTOR, PLUG BLK
Q101	5230781120	SI. TR. 2SC1740SLN
Q102	5230781120	SI. TR. 2SC1740SLN
Q103	5230019020	TR., 2SA933SLN 0.3 140
Q104	5230781120	SI. TR. 2SC1740SLN
Q105	5231761300	SI. TR. 2SD734F 0.6 250
R116	5280020700	VR., SEMI FIXED 1KB
U101	5232252520	TR., DIGITAL RT1N241S
U102	5232252520	TR., DIGITAL RT1N241S
U103	5232252520	TR., DIGITAL RT1N241S

## JOINT PCB ASSY

REF.NO.	PART NO.	DESCRIPTION
	*5200219200	JOINT PCB ASSY
	*5210219200	JOINT PCB
C301	5170352000	C., MYLAR 0.001MF/100V JT
C302	5171856000	0.010UF 100V J VT
C303	5171856000	0.010UF 100V J VT
C304	5171856000	0.010UF 100V J VT
C305	5260266850	C., ELEC. 22UF 25V M SME
C306C307	5260266850	C., ELEC. 22UF 25V M SME
D301	5224015020	DIODE, 1SS133T-77
D302	5224015020	DIODE, 1SS133T-77
J301	5336278000	CON., SOCKET 5513-10APB
J302	5336279000	CON., SOCKET 5513-20APB
R311	5240030120	R., CARBON R20 6.2K FT
R312	5240029220	R., CARBON 2.7K R-10 T
R313	5240029820	R., CARBON 4.7K R-10 T
R314	5240028220	R., CARBON 1K R10 T
R315	5240028220	R., CARBON 1K R10 T
U301	5220416200	IC., M5218L,

## ADJ SW PCB ASSY

REF.NO.	PART NO.	DESCRIPTION
	*5200219100	ADJ SW PCB ASSY
	*5210219100	ADJ SW PCB
D301	5225006900	LED, PR3432S RED MU-20
D303	5224015020	DIODE, 1SS133T-77
J301	5122373000	CON., SOCKET 3024-2AH
P302	5336276000	CON., PLUG 5512-20A
R325	5280021100	R., TRIMMER 4.7KB
S301	5300045900	SW., PUSH 3G SPUJ30

Parts marked with \* require longer delivery time.



## COUNTER SW PCB ASSY

REF.NO.	PART NO.	DESCRIPTION
	*5200218600	COUNTER SW PCB ASSY
	*5210218600	COUNTER SW PCB
	*5800942700	LED SPACER L=11
D501	5224015020	DIODE,1SS133T-77
D502-D505	5225017100	LED,TLR226
P501	5336212800	CON., PLUG 5089-8A
P502	5336210500	CON., PLUG 5129-5A
P503-D506	5336115200	CON., SOCKET
S501	5300046000	SW.,PUSH 3G SPUZ32-LBWL
S502 S503	5300046100	SW.,PUSH 3G SPUZ32-SRS
U501	5232252520	TR.,DIGITAL RT1N241S
U502	5232252520	TR.,DIGITAL RT1N241S
U503	5232252520	TR.,DIGITAL RT1N241S
U504	5232252520	TR.,DIGITAL RT1N241S

## ADJ VR PCB ASSY

REF.NO.	PART NO.	DESCRIPTION
	*5200219000	ADJ VR PCB ASSY
	*5210219000	ADJ VR PCB
P301	5336275000	CON.,PLUG 5512-10A
R301-R304	5283505800	R.,TRIMMER 10KBX4

## B.T. SENSOR PCB ASSY

REF.NO.	PART NO.	DESCRIPTION
	*5200219400	B.T. SENSOR PCB ASSY
	*5210219400	B.T. SENSOR PCB
Q104	5228011600	PHOTO-REFLECTOR
	5800735900	SPACER

## MOTHER PCB ASSY

REF.NO.	PART NO.	DESCRIPTION
	*5200218000	MOTHER PCB ASSY [J, US, C, GE]
	*5200218010	MOTHER PCB ASSY [E, UK, A]
	*5210218000	MOTHER PCB
	*5332015800	HOLDER, FUSE [E, UK, A]
	*5033291000	PLATE,INSULATOR
	*5033295000	TUBE,INSULATOR
	*5800933700	HEAT SINK
	*5555590000	PLATE.PCB EARTH;A
	5330509600	JACK,4P
C120 C121	△5260272210	3300UF 25V M SME VF
C132 C133	△5260272210	3300UF 25V M SME VF
C140 C141	△5260272210	3300UF 25V M SME VF
C142	△5260271010	1000UF 25V M SME VF
C143	△5260272110	3300UF 16V M SME VF
C147	△5260271510	2200UF 16V M SME VF
D101	5224015020	DIODE,1SS133T-77
D102	5224015020	DIODE,1SS133T-77
D103	5224015020	DIODE,1SS133T-77
D104	5224015020	DIODE,1SS133T-77
D105	5224015120	DIODE,MC911
D106	5224015220	DIODE,MC921
D107	5224015120	DIODE,MC911
D108	5143089000	DIODE,W03C
D109	5143089000	DIODE,W03C
D110-D112	△5228005000	SILICON STACK W02
D113 D114	△5143089000	DIODE,W03C
D115-D117	5224015020	DIODE,1SS133T-77
D118	5224012920	DIODE,1S2473
D119	5224015020	DIODE,1SS133T-77
D120	5224012920	DIODE,1S2473
D121	5224015020	DIODE,1SS133T-77
D126	5224015020	DIODE,1SS133T-77
D171-D175	5224015020	DIODE,1SS133T-77
F001-F002	△5142188000	FUSE,1.6A-250V (T) [E, UK, A]
	5181209000	JUMPER WIRE P=20 [J, US, C, GE]
F003	△5142186000	FUSE,MINI,800MA (T) [E, UK, A]
	5181765000	JUMPER WIRE P=15 [J, US, C, GE]
L101 L201	5286002100	COIL,CHOKE 1.5MH
P101	5336126600	CON.,PLUG WHT
P102	5336126900	CON.,PLUG 8263-0912 WHT

Parts marked with \* require longer delivery time.

[US]:U.S.A. [E]:EUROPE [UK]:U.K. [C]:CANADA [A]:AUSTRALIA [GE]:GENERAL EXPORT [J]:JAPAN

P103	5336135200	CON.,PLUG	8263-0212	RED
P104	5336135600	CON.,PLUG	8263-0612	RED
P105	5336126400	CON.,PLUG	WHT	
P106	5122363000	CON., M	11P	
P107	5122358000	CON., M	6P	
P108	5336126500	CON.,PLUG	WHT	
P109	5336126500	CON.,PLUG	WHT	
P110	5336126800	CON.,PLUG	8263-0812	WHT
P111	5336126300	CON.,PLUG	8263-0312	WHT
P112	5336126400	CON.,PLUG	WHT	
P113	5336274800	CON.,PLUG	5512-08A	
P114	5336126300	CON.,PLUG	8263-0312	WHT
P115	5122129000	CON.,PLUG	5045-05A	W
P116	5336126300	CON.,PLUG	8263-0312	WHT
P117	5336135300	CON.,PLUG	8263-0312	RED
P118	5336274800	CON.,PLUG	5512-08A	
P119	5336275600	CON.,PLUG	5512-16A	
P120	5336275600	CON.,PLUG	5512-16A	
P121	5336274600	CON.,PLUG	5512-06A	
P122	5336275000	CON.,PLUG	5512-10A	
P123	5336126300	CON.,PLUG	8263-0312	WHT
Q101Q201	5230775020	TR	2SC2878-B	
Q102Q202	5230775020	TR	2SC2878-B	
Q103Q203	5230775020	TR	2SC2878-B	
Q104Q204	5230775020	TR	2SC2878-B	
Q105Q205	5230775020	TR	2SC2878-B	
Q106	5231761300	SI.	TR.2SD734F 0.6	250
Q107	△5145087000	SI.	TR.2SD-313E	30 8
Q108	△5145129000	SI.	TR.2SB-507	30 8
Q109	△5145087000	SI.	TR.2SD-313E	30 8
Q110	△5145129000	SI.	TR.2SB-507	30 8
Q111	△5145087000	SI.	TR.2SD-313E	30 8
Q112	5230508400	SI.	TR.2SB698F 0.6	250
R101R201	5280021300	VR,	SEMIVARIABLE	10KB
R102R202	5280021300	VR,	SEMIVARIABLE	10KB
R103R203	5280021300	VR,	SEMIVARIABLE	10KB
R104R204	5280021700	VR,	SEMIVARIABLE	47KB
R105R205	5280021700	VR,	SEMIVARIABLE	47KB
R106R206	5280021700	VR,	SEMIVARIABLE	47KB
R107R207	5280021700	VR,	SEMIVARIABLE	47KB
R108R208	5280021700	VR,	SEMIVARIABLE	47KB
R109R209	5280021700	VR,	SEMIVARIABLE	47KB
R150 R151	△5183578000	R.,	100 OHM	INCOMBUST.
R152	△5181984000	R.,	270 OHM	INCOMBUST.
U101	5232252620	TR.,DIGITAL	RT1P241S	
U102	5232252620	TR.,DIGITAL	RT1P241S	
U103	5232252620	TR.,DIGITAL	RT1P241S	
U104	5232252520	TR.,DIGITAL	RT1N241S	
U105	5232252520	TR.,DIGITAL	RT1N241S	
U106	5232252520	TR.,DIGITAL	RT1N241S	
U107 U207	5232252520	TR.,DIGITAL	RT1N241S	
U108 U208	5232252520	TR.,DIGITAL	RT1N241S	
U109 U209	5232252520	TR.,DIGITAL	RT1N241S	
U110 U210	5232252520	TR.,DIGITAL	RT1N241S	
U111 U211	5232252520	TR.,DIGITAL	RT1N241S	
U112 U212	5232252520	TR.,DIGITAL	RT1N241S	
U113	5232252520	TR.,DIGITAL	RT1N241S	
U114	5232252520	TR.,DIGITAL	RT1N241S	
U115	5232252520	TR.,DIGITAL	RT1N241S	

U116	5232252520	TR.,DIGITAL	RT1N241S	
U117	5220019000	IC.,	TC4001BP	
U118	5220019100	IC.,	TC4011BP	
U119	5220419400	IC.,	LC4066B	
U120	5220419400	IC.,	LC4066B	
U121	5232252520	TR.,DIGITAL	RT1N241S	
U122	5220414300	IC.,	NJM4560	
U123 U223	5220431100	IC.,	NJM5532S	
U124 U224	5242117800	R.,	ARRAY RMN Z8178	
U125	5220414300	IC.,	NJM4560	
U126	5292204800	MODULE,	OSC	
U127	5232252520	TR.,DIGITAL	RT1N241S	
U128	5232252520	TR.,DIGITAL	RT1N241S	
U129	5232256500	TR.,DIGITAL	2SA 1527	
U130	5232252520	TR.,DIGITAL	RT1N241S	
U131	△5220413000	IC.,	NJM78M12A,	
U132	△5220420400	IC.,	NJM79M12A	
U133	5232252520	TR.,DIGITAL	RT1N241S	
U134	5232252620	TR.,DIGITAL	RT1P241S	
U135	5232252520	TR.,DIGITAL	RT1N241S	
U136	5232252520	TR.,DIGITAL	RT1N241S	
U137	5232252520	TR.,DIGITAL	RT1N241S	
U138	5232252520	TR.,DIGITAL	RT1N241S	
U139	5232252620	TR.,DIGITAL	RT1P241S	
U140	5232252620	TR.,DIGITAL	RT1P241S	
U171	5232252520	TR.,DIGITAL	RT1N241S	
U172	5232252520	TR.,DIGITAL	RT1N241S	
U173	5232252520	TR.,DIGITAL	RT1N241S	
U174	5220017200	IC.,	HD14069UBP,	

VR PCB ASSY

REF.NO.	PART NO.	DESCRIPTION
	*5200218900	VR PCB ASSY
	*5210218900	VR PCB
	*5800824600	PLATE, VR
	*5800933000	GEAR ASSY,
	*5800933100	PLATE, GEAR
	*5800933200	GEAR
	*5800933300	FELT
	*5785153700	WASHER, WAVE BWW-608
	*5800933400	WASHER
	*5786109000	RING, CS
	*5782013004	BOLT, HEXAGON M3X4
	*5800933500	GEAR B
	*5800933600	BELT,TIMING
R102	5282411600	VR.,10KAX2 1S2UVR 16
R103 R203	5282016000	VR.,10KA 1S1UVR 16
R201	5280020900	VR., SEMI-FIXED 2.2KB
U101 U201	5286000200	COIL,TRAP 100KHZ

Parts marked with \* require longer delivery time.

- U151, U152---NUM4560
- U153~155---RTIN241S
- U156---CX20187
- U157---RTIN241S
- U160---JPC1297CA

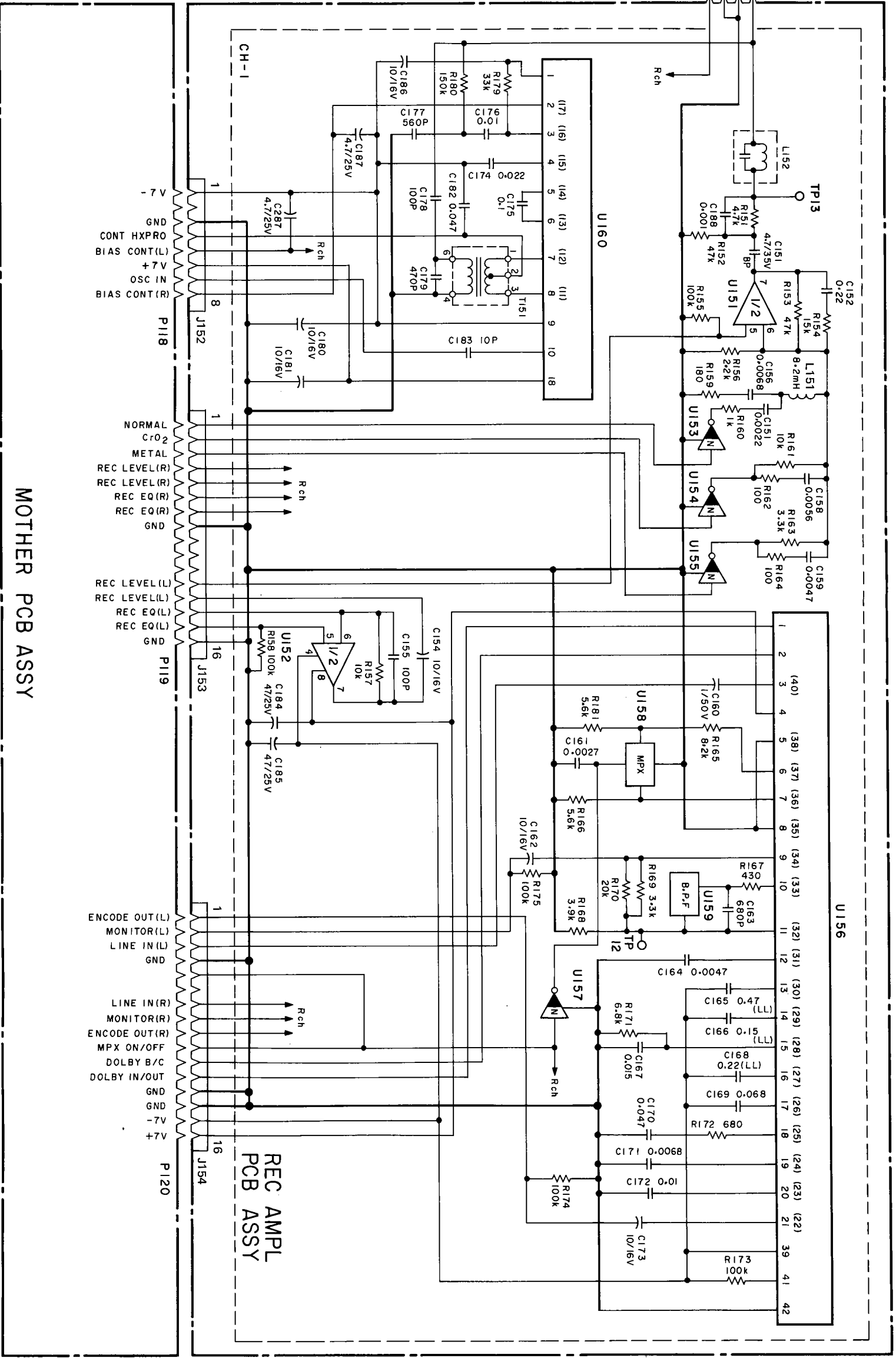

MOTHER PCB ASSY

REC AMPL PCB ASSY

**TASCAM**  
TEAC Professional Division

**SCHEMATIC DIAGRAMS**

# 122MKII

## Master Cassette Deck

**INSTRUCTIONS FOR SERVICE PERSONNEL**  
**BEFORE RETURNING APPLIANCE TO THE CUSTOMER, MAKE LEAKAGE-**  
**CURRENT OR RESISTANCE MEASUREMENTS TO DETERMINE THAT EXPOSED**  
**PARTS ARE ACCEPTABLY INSULATED FROM THE SUPPLY CIRCUIT.**

1 2 3 4 5 6 7

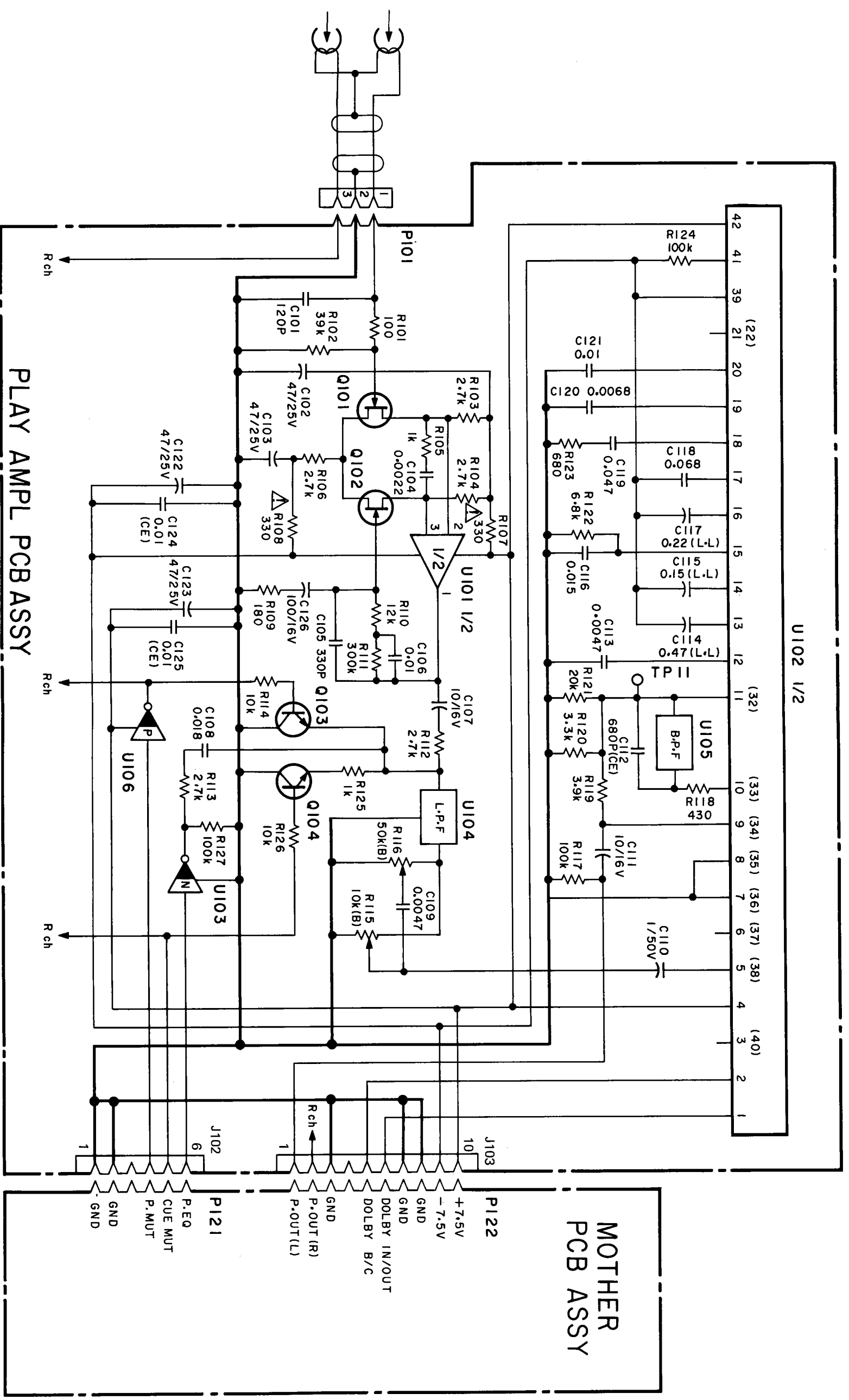

**PLAY AMPL PCB ASSY**

- U101-----NJM4562DD
- U102-----CX20187
- U103-----RT1N241S
- U106-----RT1P241S
- Q101,102-----2SK68AM
- Q103-----2SC2878B
- Q104-----2SC2603F

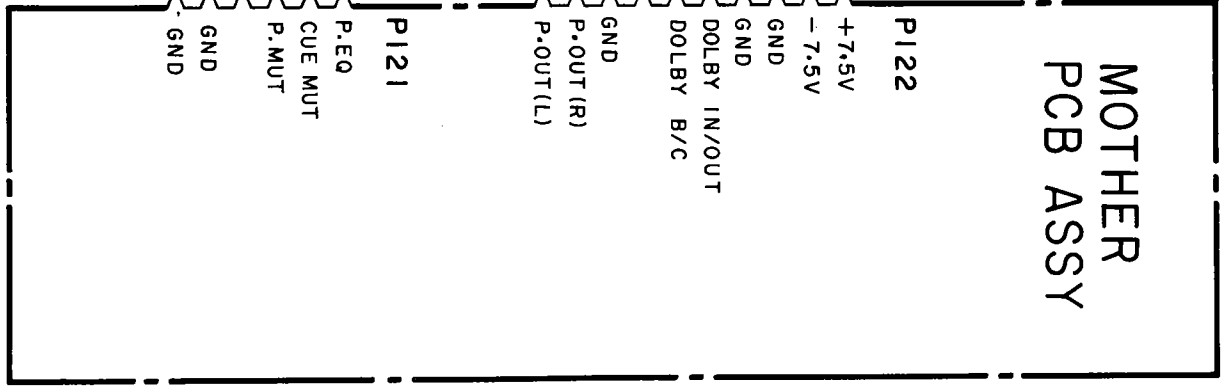

ADJUSTMENT VR PCB ASSY

JOINT PCB ASSY

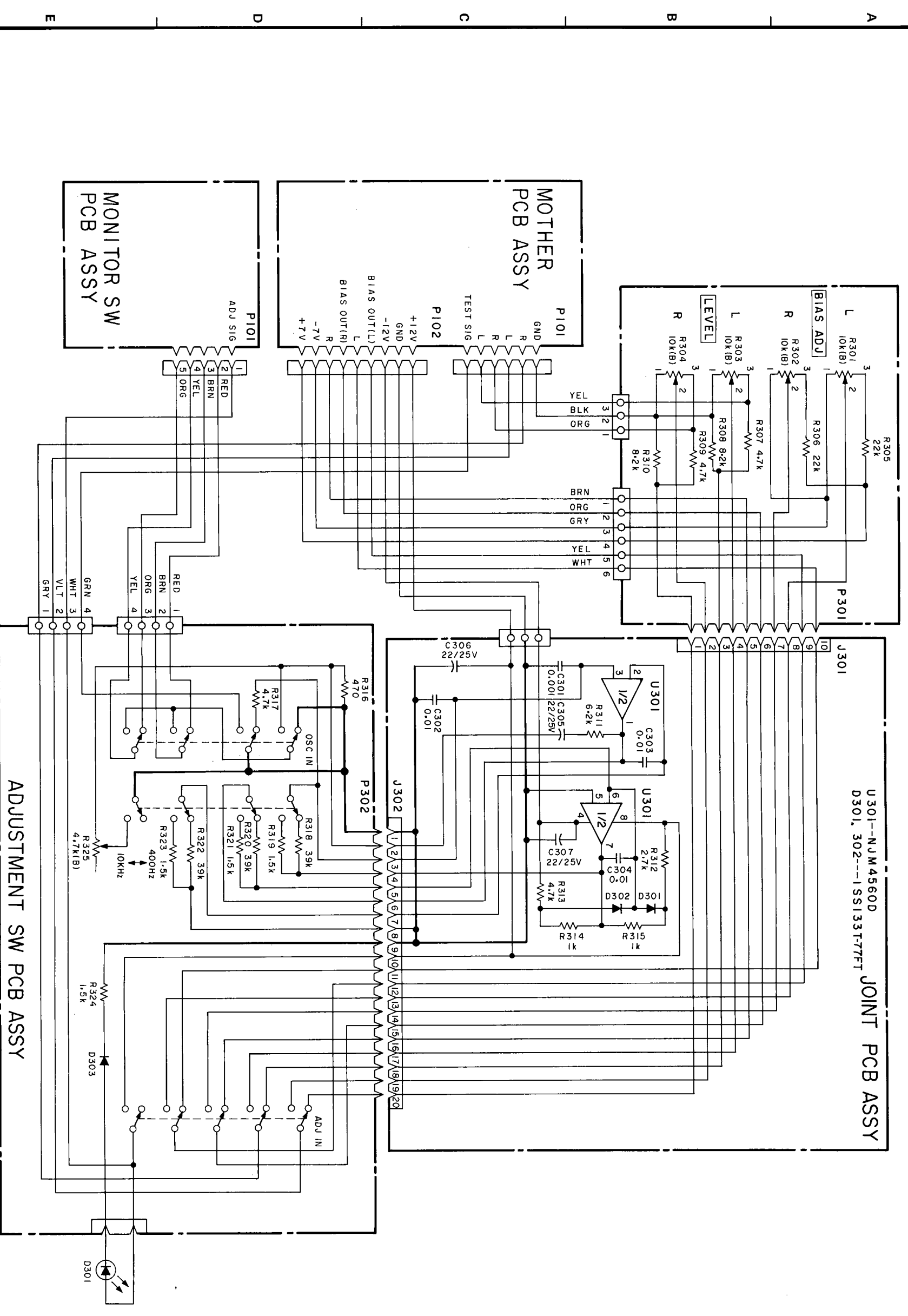

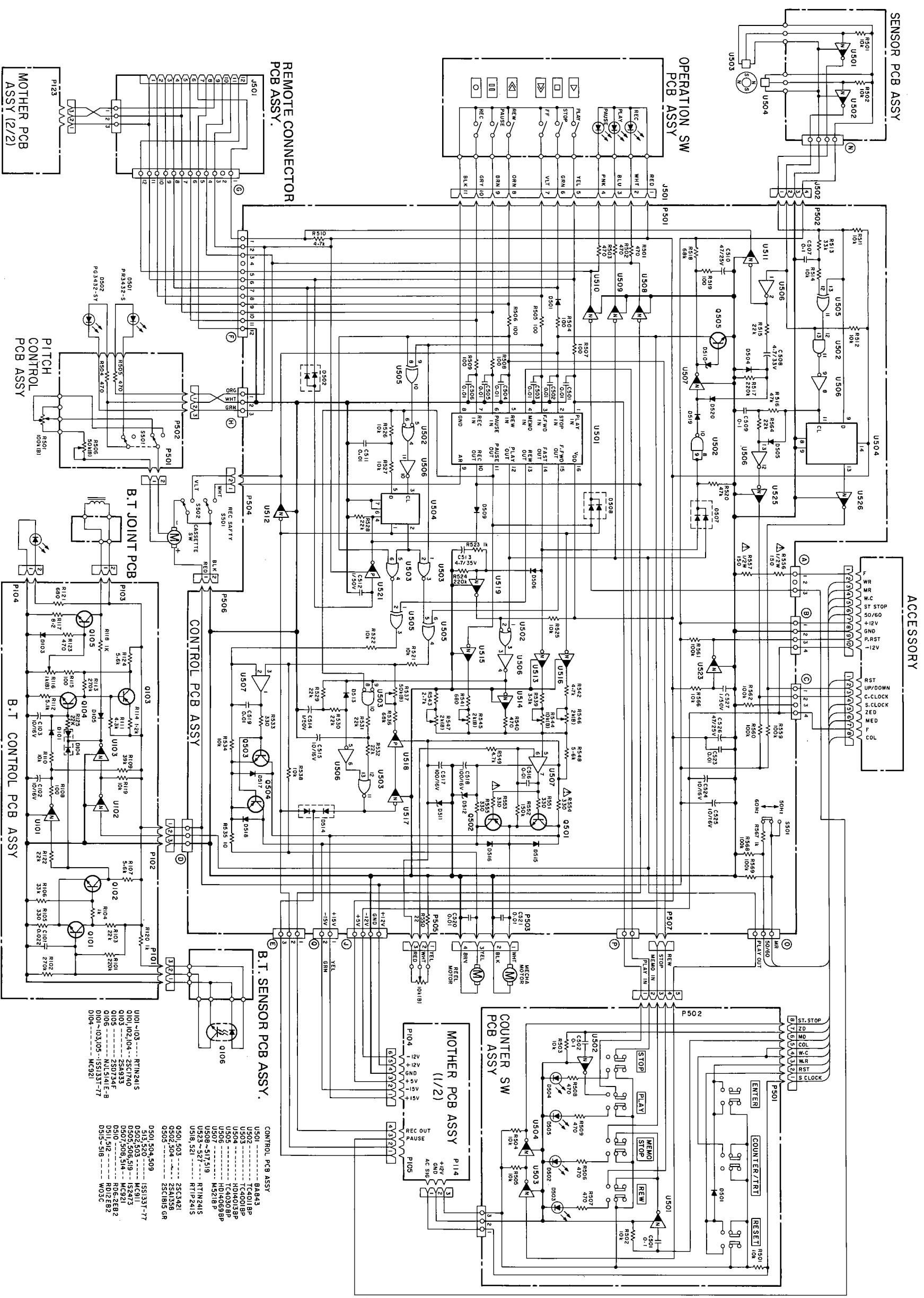

1 2 3 4 5 6 7

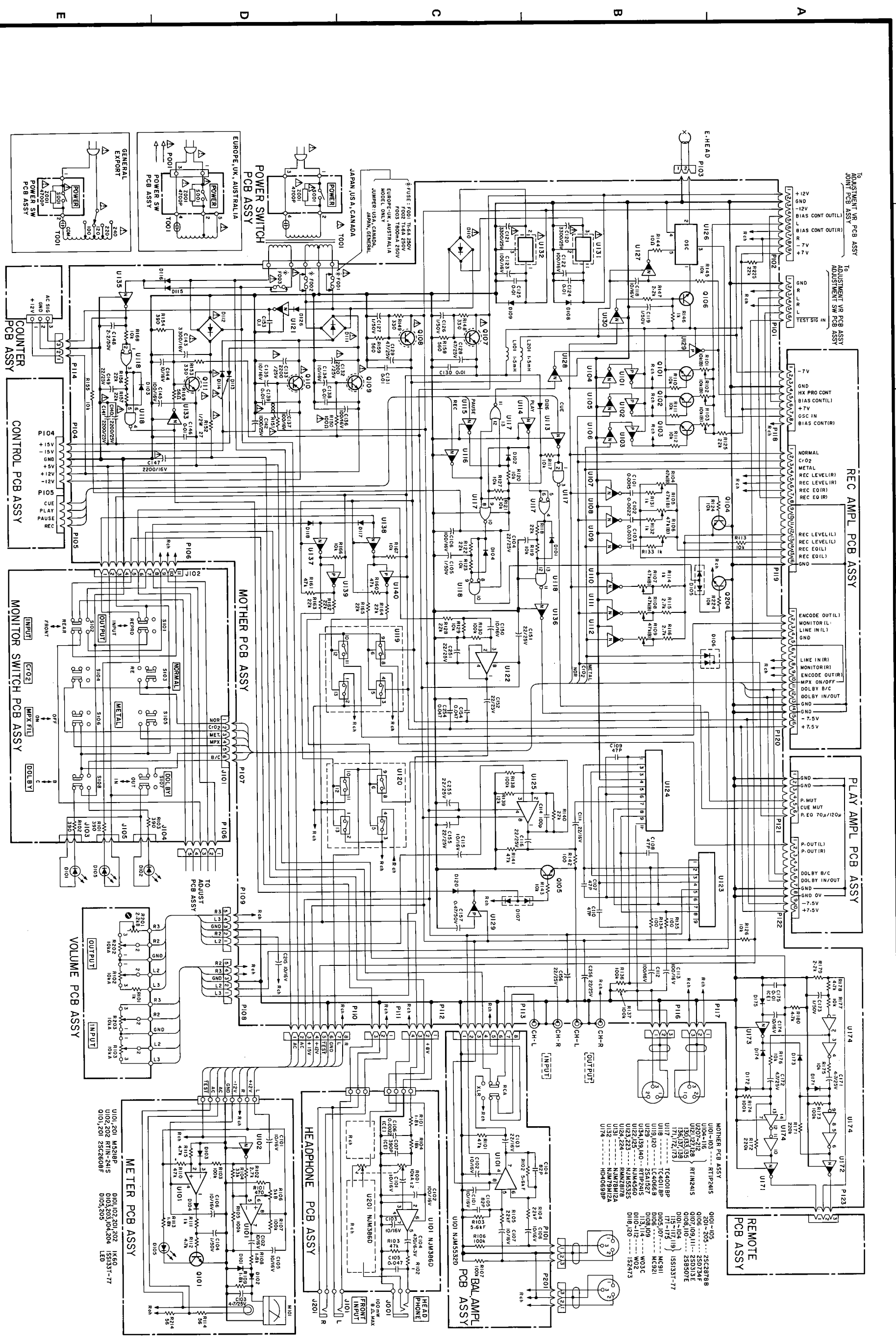

1 2 3 4 5 6 7



## METER PCB ASSY

REF.NO.	PART NO.	DESCRIPTION
	*5200218300	METER PCB ASSY
	*5210218300	METER PCB
	*5800385100	SPACER, LED
	*5800824500	PLATE, METER
	*5783603008	SCREW, BIND M3X8
	*5788101800	TUBE, UL AWG-18
D101 D102	5224015400	DIODE, 1K60
D103 D104	5224015020	DIODE, 1SS133T-77
D105 D205	5225006900	LED, PR3432S RED
D201 D202	5224015400	DIODE, 1K60
D203 D204	5224015020	DIODE, 1SS133T-77
M101 M201	5296006101	METER, VU
Q101 Q201	5230780920	SI. TR. 2SC2603F 0.3 200
R114 R214	5240025220	R., CARBON 56 OHM J FT
R115 R215	5240029820	R., CARBON 4.7K R-10 T
U101 U201	5220418800	IC, M5218P
U102 U202	5232252520	TR., DIGITAL RT1N241S

## MONITOR SW PCB ASSY

REF.NO.	PART NO.	DESCRIPTION
	*5200218500	MONITOR SW PCB ASSY
	*5210218500	MONITOR SW PCB
D101-D103	5225016500	LED, PR5551K
J101	5336115600	CONNECTOR, SOCKET
J102	5336116100	CONNECTOR, SOCKET
J103-J105	5122373000	CON., SOCKET 3024-2AH
P101	5336128500	CON., PLUG WHT
S101	5300043400	SW., PUSH 8 GANG

## H.PHONE PCB ASSY

REF.NO.	PART NO.	DESCRIPTION
	*5200218400	H.PHONE PCB ASSY
	*5210218400	H.PHONE PCB
J001	5330012600	JACK, 3P FJ332DB-M
J101J201	5330012600	JACK, 3P FJ332DB-M
R001	5282411500	VR., 10KAX2 1S2UVR 9
U101U201	6048649000	IC, NJM386D

## BAL AMP PCB ASSY

REF.NO.	PART NO.	DESCRIPTION
	*5200218800	BAL AMP PCB ASSY
	*5210218800	BAL AMP PCB
	5300909200	SW., SLIDE 2-2
J102	5336277800	CONNECTOR, SOCKET
P101	5336128300	PLUG, CONNECTOR WHT
P201	5336139300	PLUG, CONNECTOR RED
U101	5220419600	IC, NJM5532D

## POWER SW PCB ASSY

REF.NO.	PART NO.	DESCRIPTION
	*5200218700	POWER SW PCB ASSY [J, US, C, GE]
	*5200218710	POWER SW PCB ASSY [E, UK, A]
	*5210218700	POWER SW PCB
	*5730007500	COVER, CAPACITOR [E, UK, A]
P001	5327007200	WRAPPING, TERMINAL [E, UK, A]
S001	△ 5300046200	SW., PUSH 1-1 SDDL1
Z001	△ 5267703800	SPARK-KILLER, 4700PF 400V

Parts marked with \* require longer delivery time.

[US]:U.S.A. [E]:EUROPE [UK]:U.K. [C]:CANADA [A]:AUSTRALIA [GE]:GENERAL EXPORT [J]:JAPAN

# 9. IC INTERNAL BLOCK DIAGRAMS

## ICブロック・ダイアグラム

BA843

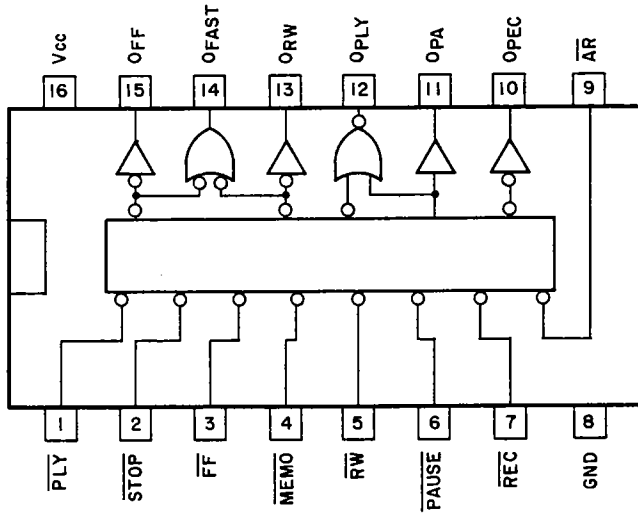

RMNZ8178

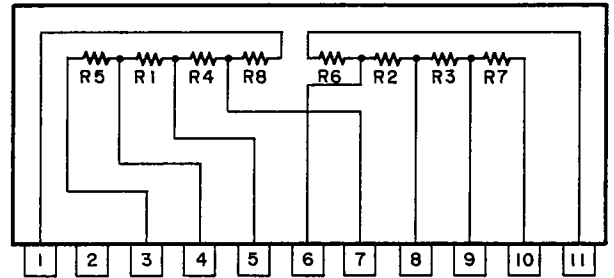

TC4011BP

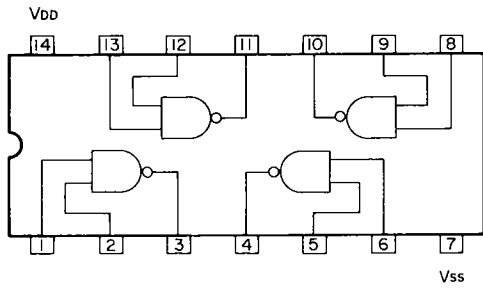

TC4001BP

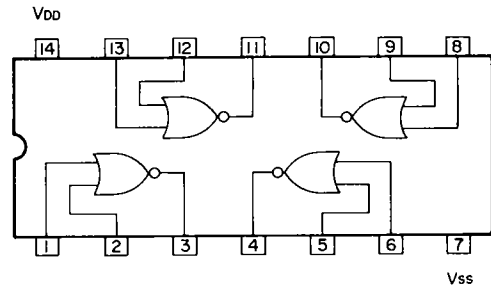

TC4030BP

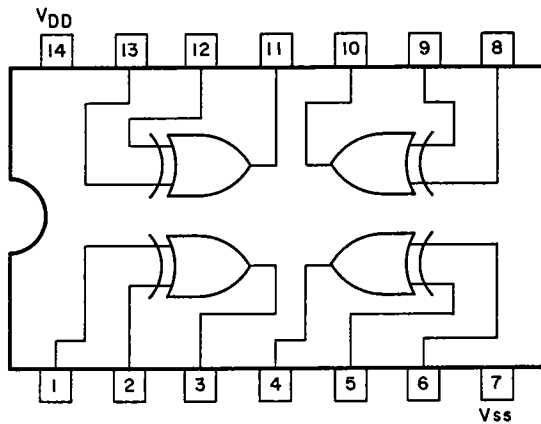

LC4066B

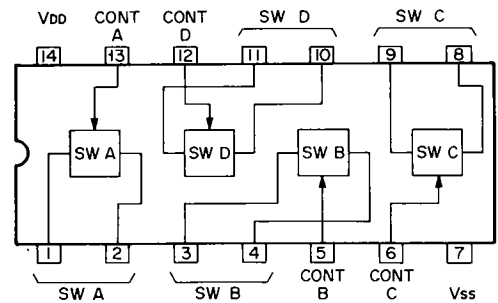

HD4069BP

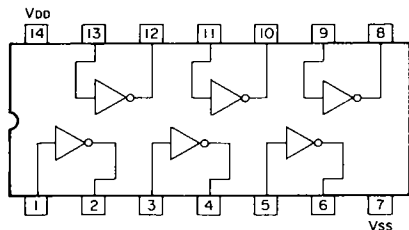

HD14069BP

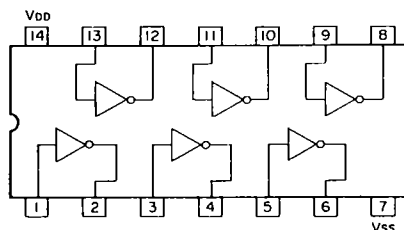

NJM4560  
NJM4562DD

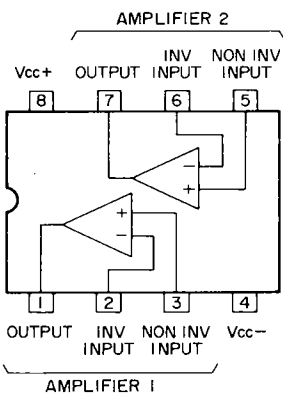

NJM5532S

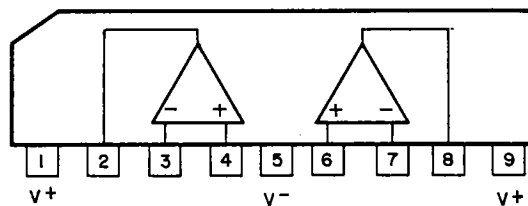

M5218P

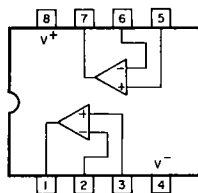

μPC1297CA

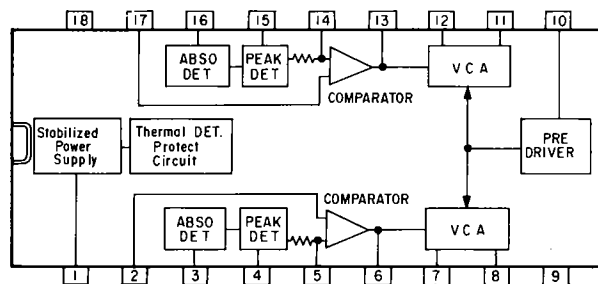

RT1N241S

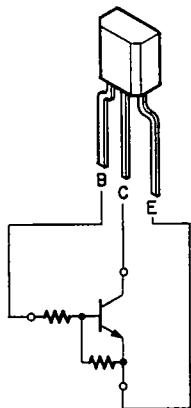

RT1P241S  
2SA1527

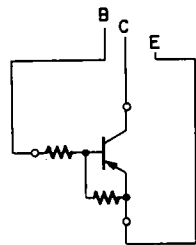

CX20187

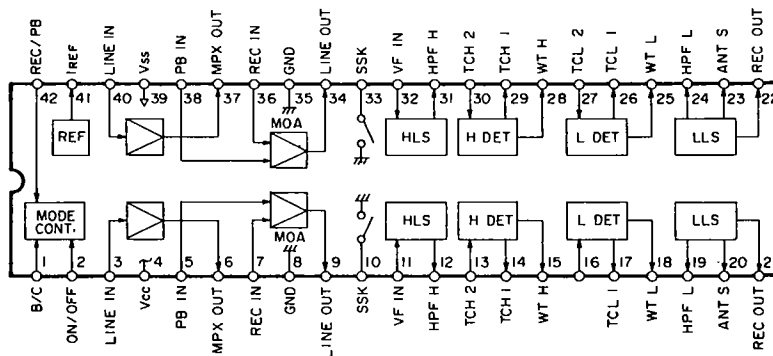

# 122MKII Master Cassette Deck

## TASCAM TEAC Professional Division

<b>ティアック株式会社</b>		営業部 181	東京都三鷹市下連雀4-15-30	電話 (0422)45-7731代
カタログの請求、製品およびサービスに関するお問い合わせは、最寄りの営業所等へご連絡ください。	札幌営業所	064	札幌市中央区南7条西2-2	くぼたビル 電話 (011)521-4101代
	仙台営業所	980	仙台市1番町2-5-5	中央ビル 電話 (022)227-1501代
	東京営業所	100	東京都千代田区永田町2-10-7	星ガ岡会館 電話 (03)592-1831代
	三鷹出張所	181	東京都三鷹市下連雀4-15-30	電話 (0422)45-7721代
	千歳出張所	280	千歳市松波1-11-3	石橋松波ビル 電話 (0472)55-1281代
	横浜営業所	221	横浜市神奈川区沢渡1-1	高島台第一ビル 電話 (045)312-3270代
	名古屋営業所	464	名古屋千種区東山通り3-2-3	電話 (052)782-4581代
	静岡出張所	420	静岡市中島大割2861-1	電話 (0542)81-6561代
	大阪営業所	564	大阪府吹田市垂水町3-34-10	電話 (06)384-5201代
	京都出張所	600	京都市下京区大宮通四条下ル四条大宮町21	電話 (075)842-0751代
	岡山出張所	700	岡山市新保1142-6	新三虎ビル 電話 (0862)25-8601代
	広島営業所	733	広島市中区西川口町13-19	電話 (082)294-4751代
	福岡営業所	812	福岡市博多区東光2-2-24	電話 (092)431-5781代
	松本サービスセンター	399-07	塩尻市広丘吉田1007-7	電話 (0263)58-6849代
	新潟サービスセンター	950	新潟市東明7-4-1	電話 (0252)86-7640代
	大宮サービスセンター	330	大宮市三橋2-846	電話 (0486)42-4551代
	沖縄サービスセンター	901-22	沖縄県宜野湾市字喜友名229	電話 (09889)2-2020代
	サービス1課	189-12	東京都武蔵村山市伊奈平2-11-1	電話 (0425)60-8918代
	技術的なお問合わせ	A V 技術相談室 189-12	東京都武蔵村山市伊奈平2-11-1	電話 (0425)60-7761代

### TEAC CORPORATION

MAIN OFFICE: 3-7-3 NAKACHO MUSASHINO TOKYO PHONE (0422) 53-1111  
SALES OFFICE: 4-15-30 SHIMORENJAKU MITAKA TOKYO PHONE (0422) 45-7741

### TEAC CORPORATION OF AMERICA

7733 TELEGRAPH ROAD MONTEBELLO CALIFORNIA 90640 PHONE (213) 726-0303

### TEAC CANADA LTD.

3610 NASHUA DRIVE UNIT 1 & 2 MISSISSAUGA ONTARIO L4V 1L2 PHONE 416-673-3303

### TEAC AUSTRALIA PTY., LTD.

115 WHITEMAN STREET SOUTH MELBOURNE VICTORIA 3205 PHONE 699-6000