

TASCAM

TEAC Production Products

34

4-Track Recorder/Reproducer



OPERATION/MAINTENANCE

5700029500

MAINTENANCE

Note:

Parts reference numbers used in the circuit description may not always correspond to those of the Model 34, except for the following sections: 1-5 Reel Motor Drive Circuit, 1-9 F.F and REW Operation, 1-10 Electrical Brake System, 1-13 Edit Control Circuit and 1-16 Amplifier Circuit Description.

NOTES

- * All resistors are 1/4 watts, 5 %, unless marked otherwise. Resistor values are in ohms (K=1,000-ohms, M=1,000,000 ohms).
- * All capacitor values are in microfarads (μ =pico-farads).
- * Δ Parts marked with this sign are safety critical components. They must always be replaced with identical components – refer to the TEAC Parts List and ensure exact replacement.
- * 0 dB is referenced to 1 V in this manual unless otherwise specified.
- * PC boards shown viewed from foil side.

SPECIFICATIONS OF THE 34

MECHANICAL

Tape:	1/4 inch, 1-1/2 mil, low noise, high output tape
Track Format:	4-track, 4-channel, track width, 0.036 inch (0.91 mm)
Reel Size:	10-1/2" NAB (large) Hub maximum
Tape Speeds:	15 inches per second (38 cm/sec), 7-1/2 inches per second (19 cm/sec); Variable, $\pm 12\%$ relative to 15 ips/7-1/2 ips
Speed Accuracy:¹⁾	$\pm 0.8\%$ deviation
Wow and Flutter:¹⁾	
15 ips	$\pm 0.06\%$ peak (DIN/IEC/ANSI weighted) $\pm 0.1\%$ peak (DIN/IEC/ANSI unweighted) 0.05 % RMS (JIS/NAB weighted) 0.07 % RMS (JIS/NAB unweighted)
7-1/2 ips	± 0.09 peak (DIN/IEC/ANSI weighted) ± 0.12 peak (DIN/IEC/ANSI unweighted) 0.07 RMS (JIS/NAB weighted) 0.09 RMS (JIS/NAB unweighted)
Fast Wind Time:	90 seconds for 10-1/2" reel 2,400 feet
Start Time:	Less than 0.8 sec. To reach standard Wow and Flutter
Capstan Motor:	FG (frequency generator) DC servo motor
Reel Motors:	Slotless DC motors x 2
Head Configurations:	3 heads; erase, record/reproduce x 2
Tape Cue:	Manual
Motion Sensing:	0.8 sec. ± 0.15 sec. delay time, stop to next motion
Dimensions:	(W) 16-3/16" x (H) 18-3/16" x (D) 10-1/8" (410 x 461 x 256 mm)
Weight:	44.1 lbs (20 kg), net

ELECTRICAL

Line Input:	
Input impedance:	50k ohms, unbalanced
Maximum source impedance:	2.5k ohms
Nominal input level:	-10 dBV (0.3 V)
Maximum input level:	+18 dBV (8.0 V)
Line Output:	
Output impedance:	1k ohms, unbalanced
Minimum load impedance:	10k ohms
Nominal load impedance:	50k ohms
Nominal output level:	-10 dBV (0.3 V)
Maximum output level:	+18 dB (8.0 V)
Bias Frequency:	150 kHz
Equalization:	NAB standard (National Association of Broadcasters) 3180 + 50 μ sec at 15 ips (38 cm/sec), 7-1/2 ips (19-cm/sec) 0 VU reference; 250 nWb/m tape flux level
Record Level Calibration:	
Frequency Response:	
Record/Reproduce:³⁾	
15 ips	40 Hz – 22 kHz, ± 3 dB at 0 VU 40 Hz – 22 kHz, ± 3 dB at -10 VU
7-1/2 ips	40 Hz – 16 kHz, ± 3 dB at 0 VU 40 Hz – 20 kHz, ± 3 dB at -10 VU
Sync and Reproduce:²⁾	
15 ips	40 Hz – 22 kHz, ± 3 dB
7-1/2 ips	40 Hz – 20 kHz, ± 3 dB
Total Harmonic Distortion (THD):³⁾	0.8 % at 0 VU, 1,000 Hz, 250 nWb/m 3 % at 13 dB above 0 VU, 1,000 Hz, 1,116 nWb/m
Signal-to-Noise Ratio:³⁾	At a reference of 1 kHz, at 13 dB above 0 VU, 1,116 nWb/m
15 ips	68 dB A weighted (NAB), 60 dB unweighted
7-1/2 ips	66 dB A weighted (NAB), 58 dB unweighted 92 dB A weighted (NAB), with dbx* 82 dB unweighted, with dbx
Adjacent Channel Crosstalk (Overall):³⁾	Better than 50 dB down at 1,000 Hz, 0 VU
Erase:³⁾	Better than 65 dB at 1 kHz, +10 VU reference
Headroom:	Recording Amplifier – Better than 25 dB above 0VU at 1 kHz

Connectors:

Line inputs and outputs:

RCA jack

Remote control:

Multi-Pin jack

Punch in/out remote:

Phone jack (Tip-Sleeve)

dbx unit:

Multi-Pin jack

Power Requirement:

100/120/220/240 V AC, 50/60 Hz, 73 W (General Export Model)

120 V AC, 60 Hz, 73 W (USA/Canada Model)

220 V AC, 50 Hz, 73 W (Europe Model)

240 V AC, 50 Hz, 73 W (UK/AUS Model)

In these specifications, 0 dBV is referenced to 1.0 Volt. Actual voltage levels also are given in parenthesis. To calculate the 0 dB = 0.775 Volt reference level (i.e., 0 dBm in a 600-ohm circuit) add 2.2 dB to the listed dB value; i.e., -10 dB re: 1 V = -7.8 dB re: 0.775 V.

1) Specifications were determined using TEAC Test Tape YTT-2004/YTT-2003.

2) Specifications were determined using TEAC Test Tape YTT-1004/YTT-1003.

3) Specifications were determined using TEAC Test Tape YTT-8063.

Changes in specifications and features may be made without notice obligation.

*dbx is a trademarks of dbx Inc.

Options for:

Mounting (EIA Standard 19 inch rack):

CS-607 Console Rack, RM-300 Rack Mount Angle and

T-0804 Blank Panel (normally 2 panels used)

Remote control:

Full transport function available with RC-71

Punch in/out remote control:

Punch in/out function available with RC-30P

DBX noise reduction:

4-channel DBX unit DX-4D

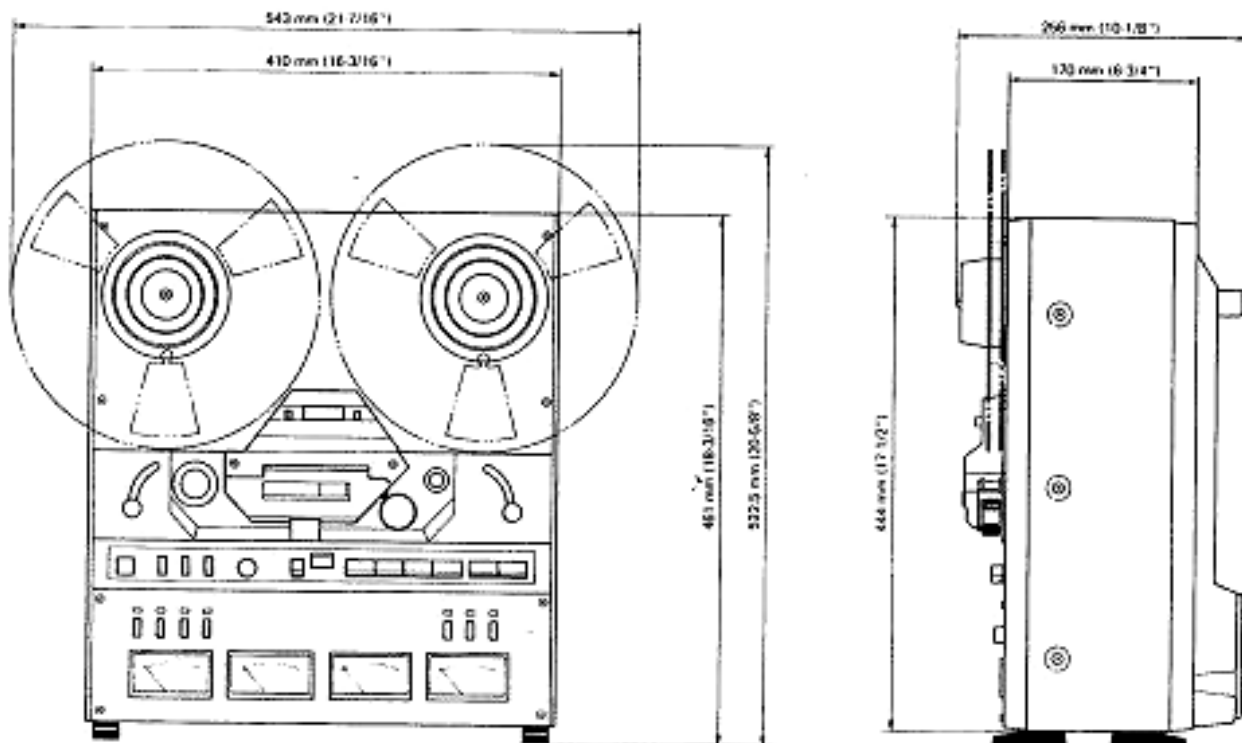

SERVICE CHART

ADJUST STEP	WHAT IS IT CALLED	SIGNAL SOURCE AND AMOUNT	WHAT TEST GEAR TO USE	WHAT IS THE RECORDER DOING?	POINT TO ADJUST	WHAT READING TO ADJUST FOR
1	Reproduce head Alignment	TEAC YTT-1003 Playback Alignment Test Tape (7-1/2 ips)	VTVM and Oscilloscope with vertical and horizontal inputs connected to OUTPUT tracks 1 and 4.	Playback at 7-1/2 ips speed. OUTPUT SELECT at REPRO.	Repro head #3 azimuth adjusting screw.	Adjust for maximum output and for output of tracks 1 and 4 less than 90° out of phase. (at 12.5 kHz)
2	Record/sync head Alignment	Same as above	Same as above	Playback at 7-1/2 ips speed. OUTPUT SELECT at SYNC	Record/sync head #2 azimuth adjusting screw	Same as above (at 12.5 kHz)
3 *	Reproduce Level (head #3)	TEAC YTT-1004 Playback Alignment Test Tape (15 ips) Play 400Hz	VTVM connected to OUTPUT jack	Playback at 15 ips speed. OUTPUT SELECT at REPRO	Trim pot #1 R120 (REPRO CAL)	-10 dB (0.3 V) on VTVM
4 *	Sync Reproduce Level (head #2)	TEAC YTT-1004 Playback Alignment Test Tape. Play 400 Hz reference level signal	Same as above	Playback tape at 15 ips. OUTPUT SELECT at SYNC	Trim pot #2 R122 (SYNC CAL)	-10 dB (0.3 V) on VTVM
5 *	Meter Adjustment	Same as above	VU Meter	Same as above	Trim pot #3 R141 (METER CAL)	Adjust to read 0 VU on VU meters
<p>REPEAT STEP MARKED WITH AN ASTERISK FOR EACH CHANNEL. THE ADJUSTMENT NUMBERS ARE THE SAME BUT THE CIRCUIT BOARD LOCATION, INPUT/OUTPUT TERMINAL NUMBERS, VU METERS, ETC., WILL BE DIFFERENT DEPENDING ON THE CHANNEL.</p>						
6 *	REPRO EQ at 15 ips speed (head #3)	YTT-1004 Test Tape Play 20 kHz signal on the tape.	VTVM connected to OUTPUT terminal	Playback at 15 ips speed. OUTPUT SELECT at REPRO	Trim pot #4 R108 (REPRO EQ)	Adjust to read -20 dB on VTVM
7 *	Sync Reproduce EQ at 15 ips speed (head #2)	Same as above	Same as above	Playback at 15 ips speed. OUTPUT SELECT at SYNC	Trim pot #5 R110 (SYNC EQ)	Same as above
8 *	REPRO EQ at 7-1/2 ips speed (head #3)	YTT-1003 Test Tape Play 16 kHz signal on the tape.	Same as above	Playback at 7-1/2 ips. OUTPUT SELECT at REPRO	Trim pot #4 R109 (REPRO EQ)	Same as above
9 *	Sync Reproduce EQ at 7-1/2 ips speed (head #2)	Same as above	Same as above	Playback at 7-1/2 ips. OUTPUT SELECT at SYNC	Trim pot #5 R111 (SYNC EQ)	Same as above
10 *	Input Level	400 Hz signal at -10 dB from oscillator connected to INPUT jack	Same as above	Stop mode OUTPUT SELECT at INPUT	Trim pot #6 R156 (INPUT LEVEL)	Same as above

ADJUST STEP	WHAT IS IT CALLED	SIGNAL SOURCE AND AMOUNT	WHAT TEST GEAR TO USE	WHAT IS THE RECORDER DOING?	POINT TO ADJUST	WHAT READING TO ADJUST FOR
11 •	Bias Level Adjustment. Refer to MAINTENANCE section for more precise adjustment.	10 kHz, -10 dB oscillator signal connected to INPUT jack	VTVM connected to OUTPUT jack	Record signal on type of tape that will be used for actual recording. FUNCTION SELECT at ON OUTPUT SELECT at REPRO Tape speed at 15 ips	Trim capacitor #8 C134 (BIAS LEVEL)	While recording adjust trim pot until VU meter indication rises to peak value, then turn pot further clockwise until signal drops off by 3 – 4 VU (over-bias)
12 •	Bias Trap Adjustment	No input signal	VTVM connected to Bias Trap test point TP1, negative lead to ground, positive lead to test point.	Record mode, no input signal	Trim capacitor L105	Adjust capacitor for minimum output at Bias Trap test point TP-1. See page 38 for test point location.
13 •	Record Level	400 Hz signal at -10 dB (0 VU on VU meters) connected to INPUT jack	VTVM connected to OUTPUT jack or use VU meters	Record signal on type that will be used for actual recording. FUNCTION SELECT at ON OUTPUT SELECT at REPRO. Tape speed at 15 ips	Trim pot #9 R176 (REC LEVEL)	Set for -10 dB (0.3 V) at OUTPUT jacks or 0 VU on VU meters
14 •	Record/Reproduce Frequency Response at 15 ips speed.	40 Hz to 22 kHz signal at -10 dB connected to Input jack	Same as above	Same as above	Inductor #10 L103	Check that frequency response matches limits given in Chart See page 46.
15 •	Record/Reproduce Frequency Response at 7-1/2 ips speed.	40 Hz to 20 kHz signal at -20 dB connected to Input terminals	Same as above	REcord signal on type fo tape that will be used for actual recording. FUNCTION SELECT at ON OUTPUT SELECT at REPRO tape speed at 7-1/2 ips	Inductor #10 L104	Same as above
16 •	Overall Signal-to-Noise Ratio	No input signal	VTVM connected to OUTPUT jacks	Same as above tape speed at 15 ips or 7-1/2 ips		Check for 50 dB or better

1. CIRCUIT DESCRIPTION

Signal flow and functions of the various control circuits of the tape deck are explained in detail in this section. These should be of help in analyzing any trouble which may occur and in correcting the malfunctioning circuit.

1-1. LOGIC USED IN THE TAPE DECK

(a) 2 INPUT NAND GATE

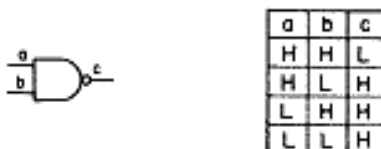

(b) 2 INPUT NOR GATE



(c) INVERTER



Note: H level = 3.4 V ~ 5 V
L level = 0 V ~ 0.6 V

1-2. SYSTEM CONTROL IC

1-2-1. Pin Assignments and Their Functions

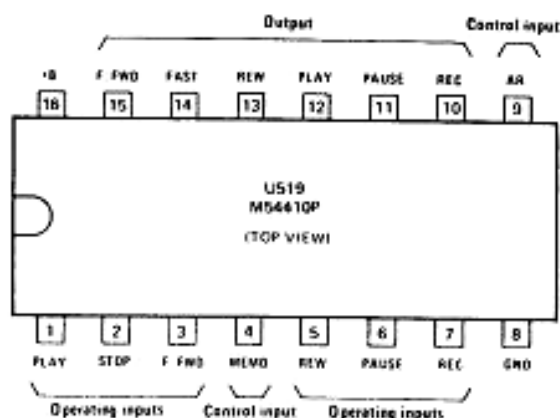

Fig. 1-1. Pin Assignments

	Pin No.	Pin name	Function
Operation inputs	1	PLAY	Reproduce start signal input terminal. Signal level: L
	2	STOP	Stop signal input terminal. Signal level: L
	3	F.FWD	Fast-forward signal input terminal. Signal level: L
	5	REW	Rewind signal input terminal. Signal level: L
	6	PAUSE	Pause signal input terminal. Signal level: L
	7	REC	Record signal input terminal. Signal level: L
Control inputs	4	MEMO	Memory input terminal (resets rewind mode when at L level)
	9	AR	Record inhibit signal input terminal (L level: record inhibited, H level: record enabled)
Outputs power	10	REC	H-level signal output terminal during record/reproduce or record/pause mode
	11	PAUSE	H-level signal output terminal during pause mode
	12	PLAY	H-level signal output terminal during reproduce mode.
	13	REW	H-level signal output terminal during rewind mode.
	14	FAST	H-level signal output terminal during rewind or fast-forward mode.
Power	15	F.FWD	H-level signal output terminal during fast-forward mode.
	8	GND	Ground terminal.
	16	+B	Power supply terminal (standard: +5 V +/- 10%, absolute maximum: +7.0 V)

1-2-2. Block Diagram

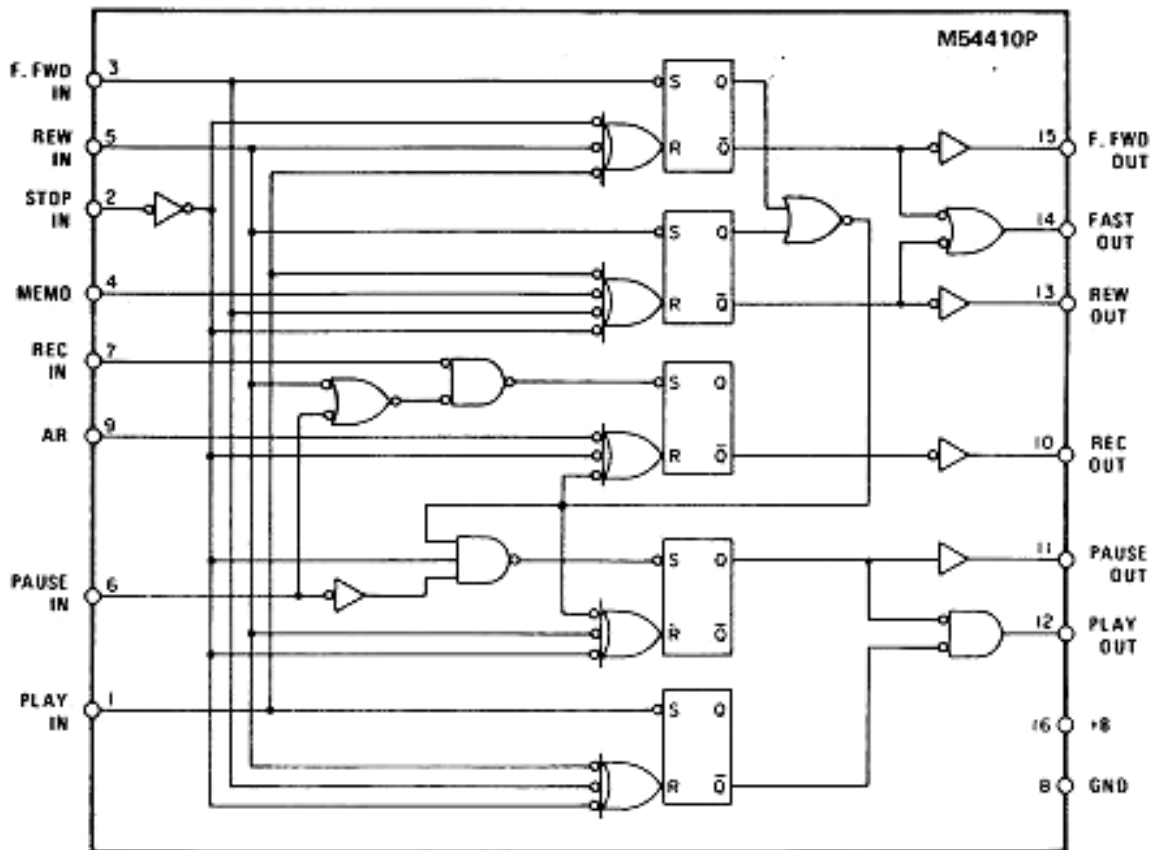

Fig. 1-2. Block Diagram

1-2-3. Input Signals and Resulting Modes

Output signal / Input signal	REC	PAUSE	PLAY	REW	FAST	F. FWD	Operating mode
PLAY	L	L	H	L	L	L	PLAY mode
STOP	L	L	L	L	L	L	STOP mode
F.FWD	L	L	L	L	H	H	F.FWD mode
REW	L	L	L	H	H	L	REW mode
PAUSE	L	H	L	L	L	L	PAUSE mode
REC and PLAY	H	L	H	L	L	L	REC/PLAY mode
REC and PAUSE	H	H	L	L	L	L	REC/PAUSE mode

- Notes:
1. The mode is set at the decaying edge of the input signal waveform.
 2. The output retains the current mode until an input signal indicating a different mode is received.
 3. Output REC remains at L as long as input AR is L.
 4. Output REW remains at L as long as input MEMO is L.

1-2-4. Mode Transition

The table below summarizes transition from one to another due to an input signal.

Current Mode Input signal	STOP	F.FWD	REW	PLAY	PAUSE	REC/PLAY	REC/PAUSE
STOP		STOP	STOP	STOP	STOP	STOP	STOP
F.FWD	F.FWD		F.FWD	F.FWD	F.FWD	F.FWD	F.FWD
REW	REW	REW		REW	REW	REW	REW
PLAY	PLAY	PLAY	PLAY		PLAY		REC/PLAY
PAUSE	PAUSE			PAUSE		REC/PAUSE	
REC and PLAY	REC/PLAY	REC/PLAY	REC/PLAY	REC/PLAY	REC/PLAY		REC/PLAY
REC and PAUSE	REC/PAUSE			REC/PAUSE	REC/PAUSE	REC/PAUSE	

Note. A diagonal line indicates that the current mode remains unchanged.

1-2-5. Operation with more than One Input Signal

When more than one input signal is received simultaneously, the deck enters the mode indicated below. When input signals applied simultaneously are removed in sequence, the mode indicated by the last signal to be removed is normally enabled. If REC and PLAY or REC

and PAUSE are combined, the record/reproduce or record/pause mode will be enabled regardless of the sequence in which the input signals are removed. If F.FWD (REW) and REC or PAUSE are combined, the fast-forward (rewind) mode will be enabled regardless of the sequence in which the input signals are removed.

Input signal A	Input signal B	Resulting mode
STOP	Any combination of F.FWD, REW, REC, PAUSE, and PLAY	STOP mode
F.FWD	REW	STOP mode
	REC and/or PAUSE	F.FWD mode
	PLAY	STOP mode
REW	REC and/or PAUSE	REW mode
	PLAY	STOP mode
REC	PAUSE	REC/PAUSE mode
	PLAY	REC/PLAY mode
	PAUSE and PLAY	REC/PAUSE mode
PAUSE	PLAY	REC/PLAY mode

1-2-6. Input/Output Levels

Input/output levels and voltages are given below.

Item	Minimum	Standard	Maximum	Absolute maximum
Maximum supply voltage	—	—	—	7.0 V
Maximum input voltage	—	—	—	5.5 V
Recommended supply voltage	4.5 V	5.0 V	5.5 V	—
H-level input voltage	2.0 V	—	—	—
L-level input voltage	—	—	0.8 V	—
Open input voltage	3.2 V	—	—	—
H-level output voltage	2.9 V	—	—	—
L-level output voltage	—	—	0.4 V	—

1-2-7. Initial Reset Circuit

See Fig. 1-3.

The initial reset circuit generates a signal which puts the deck in the stop mode as soon as the power is turned on, preventing incorrect operation during the time the DC supply voltage is unstable.

When power is turned on, current from the IC U519 charges the noise suppression capacitors (C502 ~ C507). It takes only about 20 msec to charge C502 ~ C507 because of their low capacity. When the capacitors are fully charged, the

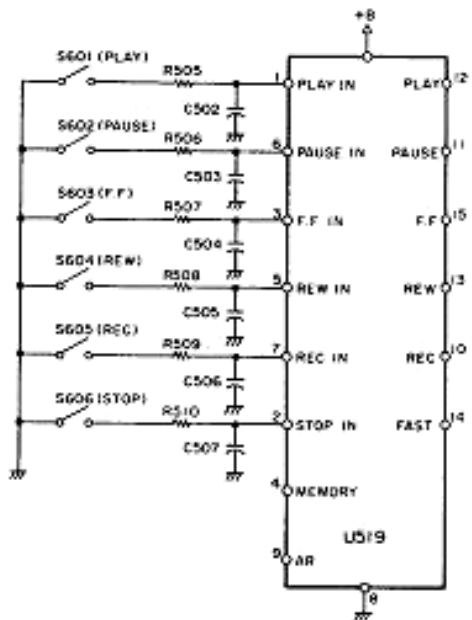

Fig. 1-3. System Control IC Input Circuit

PLAY, PAUSE, F.F., REW, and REC input terminals become HIGH. However, it takes approximately 100 msec for the STOP input terminal to rise to HIGH because of the large capacity of C507. Since STOP takes longer to become HIGH than the other input terminals, a flip-flop is set in U519 when power is turned on and the deck enters the stop mode.

Unless C507 is fully charged and the STOP input terminal is HIGH, U519 does not switch from the stop mode to any other mode even if operation signals are input.

1-3. POWER SHUT-OFF CIRCUIT

See Fig. 1-4.

A photo interruptor type shut-off switch is interlocked with the right tension arm.

1. When the tension arm deviates from its normal position, the light beam falling on the photo transistor is interrupted and the photo transistor output voltage drops, turning off Q516 and Q517. When Q516 is cut off, Q813 is also turned off and no power is supplied to terminal 6 of capstan motor assembly, and the capstan motor is deenergized.
2. When Q517 goes off, base bias current flows to the base of Q518 through R551 and Q518 goes on. Since the collector of Q518 is connected to the STOP mode switch, the tape deck is set to the STOP mode. Thus, the entire system stops when the tension arm is not set in its specified position due to tape slackness or other trouble.

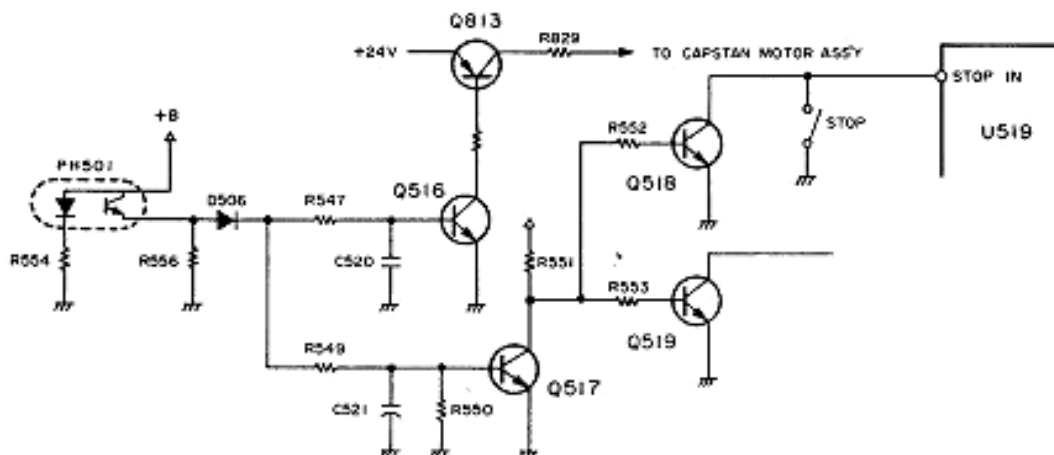

Fig. 1-4. Power Shut-Off Circuit

3. When the tension arm is in its normal position, the photo transistor receives the light beam and outputs a high level voltage to make Q516 and Q517 conduct.
4. When Q516 goes on, the Q813 base bias circuit is grounded and Q813 supplies current to the capstan motor.
5. When Q517 goes on, Q518 and Q519 are turned off, disconnecting Q518 from the stop mode switch and Q519 from the speed sensing circuit.

1-4. CAPSTAN AND BRAKE SOLENOID DRIVE CIRCUIT

The tape deck uses two solenoids; their drive circuits are shown in Fig. 1-5 (B).

1) Capstan solenoid

This solenoid operates in the PLAY mode to activate the pinch roller. The solenoid goes off in the PAUSE mode.

2) Brake solenoid

In the PLAY, F.F, and REW modes, this solenoid operates to release the reel motor brakes. The solenoid goes off in the PAUSE, STOP, F.F., and REWIND mode.

These solenoids operate as described below:

1. When the deck is in the STOP mode and the PLAY button is pressed, pin 12 of U519 goes HIGH.
2. When pin 12 goes HIGH, Q537 goes on and current flows to the base of Q538 and Q538 goes on.
3. When Q538 goes on, the ground side of the capstan solenoid coil is connected to the ground.
4. When pin 12 of U519 goes HIGH, Q539 goes on, followed by Q541 so that R614, C531 and the brake solenoid are grounded through the collector-emitter path of Q541.
5. When Q541 goes on, charging current flows to C531 through route (1) and Q535 goes on for approximately 200 msec. Then Q536 also goes on and supplies the capstan and brake solenoids with +24 V. A large solenoid current flows to ensure activation of the solenoids. Refer to Fig. 1-5(A)
6. When the charge current stops flowing, Q535 and Q536 go off, disconnecting +24 V supply. However, +12 V is supplied through D514 and solenoid activation is maintained with minimal voltage.
7. Thus, the solenoid voltage applied during activation is reduced for holding, maximizing

the activation force to ensure positive action but minimizing heating of the solenoid during holding.

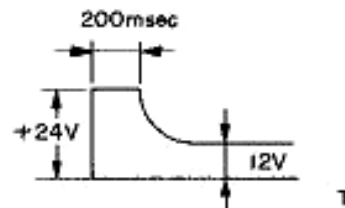

Fig. 1-5 (A). Flashing & Steady State Voltage

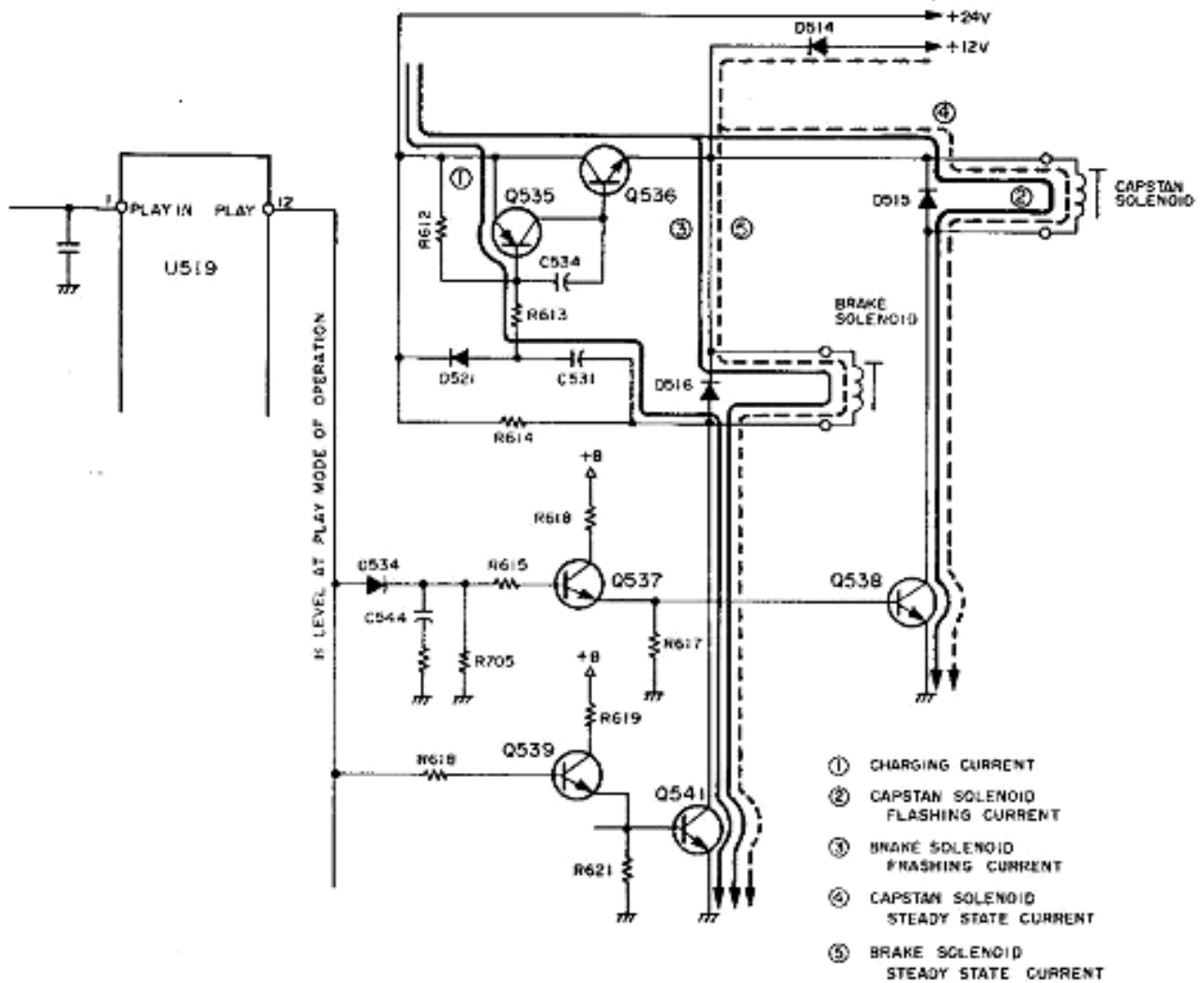

Fig. 1-5 (B). Solenoid Drive Circuit

1-5. REEL MOTOR DRIVE CIRCUIT

Reproduce (Record) Operation

See Fig. 1-6.

1. Before the PLAY button has been pushed, Q547 is cut off, and Q548, Q549 go on causing a 20 V line voltage to be applied to the hot sides of both reel motors through the collector-emitter paths of Q549 and D525. Since the opposite sides of the motor are not connected to the circuit ground through its corresponding drive circuit (Q556 and Q557, or Q560 and Q561), the motors are unable to be rotated.
2. When the PLAY button is pushed, the H level voltage is applied to the base of Q550 making it conductive. Q551 goes on and a charging current flows to the base of Q552 from the emitter-collector path of Q551, C535 and R671 for a short period (1 second) of which length is determined by the value of C535. Q552 then goes on, followed by Q553 which supplies +24 V to the hot sides of both motors until the charging current to C535 is stopped and the flashing current which is required to start the motors is provided.
3. At the same time, the H level voltage is also applied to the base of Q547 making it conductive, turning off Q548 and Q549, which in turn, cuts off the 20 V line voltage which was applied to the motor circuit.
4. Then the H level voltage is applied to the base of Q554 to turn it on, followed by Q555. When Q555 goes on, a base bias current is supplied to both right and left motor drive circuits (Q556, Q557, and Q560, Q561) through routes 1 and 2 causing the drive circuits to initiate motor driving.
5. Meanwhile, the H level voltage is differentiated by C536 and the resultant short impulse turns Q558 and Q559 on. Since the right reel motor is connected to the Q559 collector at time of PLAY start, it is driven with a higher current than that of the left, so it is able to develop more take-up torque, resulting in a smoother starting operation without tape slack.
6. The REEL size selector switch S611 determines the amount of bias current which is to be fed to both motor drive circuits by switching R680 and R698 on and off to enable proper reel drive torque.
7. After the transient or flashing current has stopped, a steady 12 V current is supplied to the motors through D524.

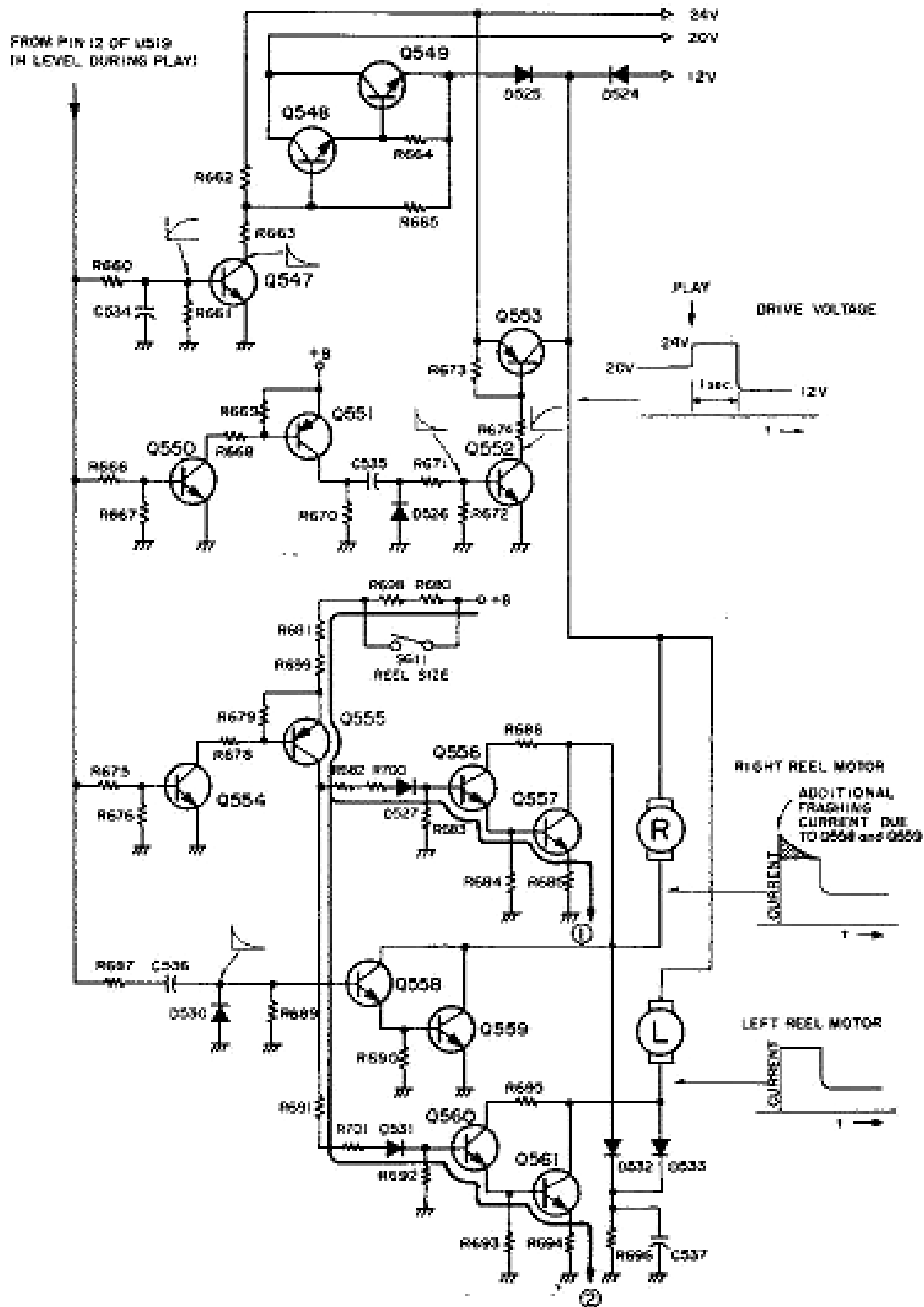

Fig. 1-6 Reel Motor Drive Circuit

1-6. TAPE DIRECTION SENSING AND COUNTER CLOCK GENERATION CIRCUIT

See Fig. 1-7.

This tape deck employs photo-sensing circuits which detect whether the tape is running or stationary and the direction in which it is running. This function is performed by two pairs of photo-interruptors, each consisting of an LED and a photo transistor. The LED and the photo transistor are respectively mounted on the upper and lower sides of a rotating disc which has four openings and is coupled to the right reel motor shaft. The second pair of photo-couplers is mounted in a similar manner, but in such a way that both output pulses produced by the two photo transistors are 90° out of phase when the disc rotates and the openings pass between each pair of LEDs and photo transistors. Thus, the pulses output represent tape speed, and the higher the pulse frequency, the higher the tape speed. The pulse output obtained from the first photo-transistor (PH502) is applied to pin 2 of U517 (an amplifier/wave shaper) and the wave-shaped pulse output developed at pin 1 of

U517 is further applied to the base of Q530, then to pin 11 of U505 (the clock terminal of flip-flop U505). The pulse output by the second photo transistor is applied to pin 6 of U517, then to pin 12 of U505 after wave-shaped in the same way as the pulse applied to pin 11 of the same flip-flop. The flip-flop checks the phase (high, low) relationship between the two input pulses applied to pins 11 and 12 and produces a high level output at pin 9 when the tape is running in forward direction and a low level output when the tape is running in reverse direction. The high level signal produced at pin 9 of U505 turns on Q532, which in turn makes Q533 conductive so that the instruction required to increment the tape counter is issued to the counter UP/DOWN input terminal. In a similar way, when the tape is running in reverse direction, the low level output is applied to the UP/DOWN input terminal to decrement the tape counter.

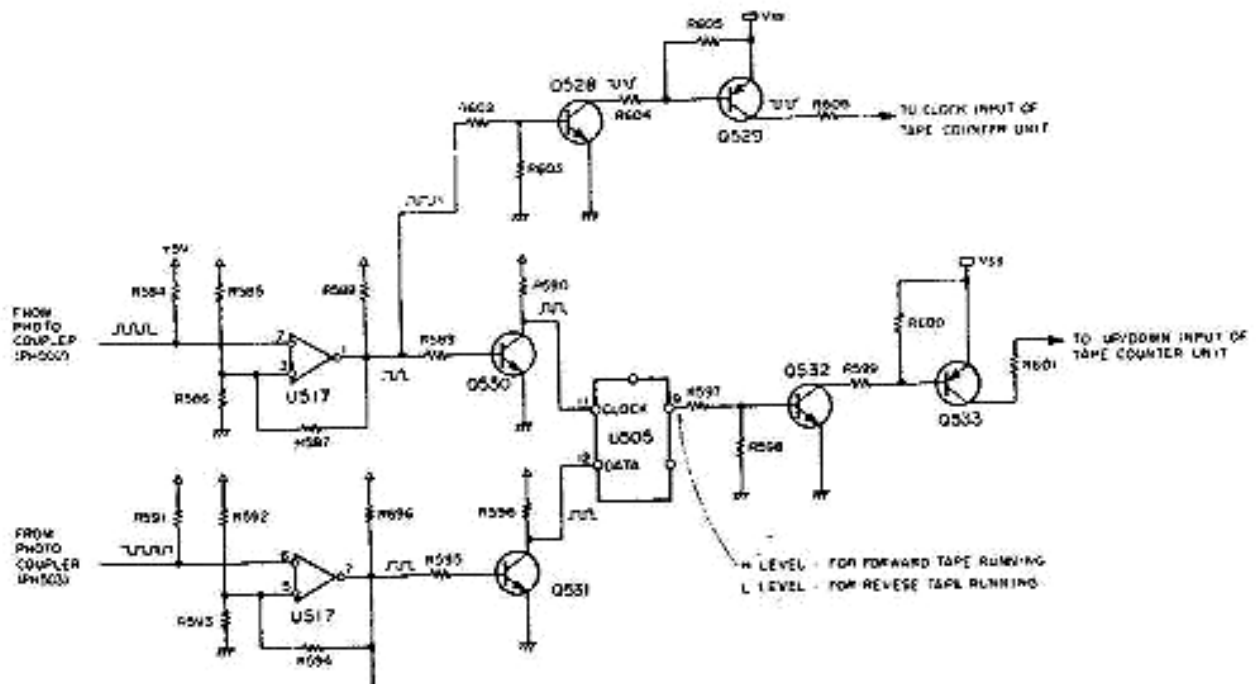

Fig. 1-7. Tape Direction Sensing and Tape Counter Clock Generation Circuit

1-9. F.F. AND REW OPERATION

See Fig. 1-9

1. As previously mentioned, both pin 3 and pin 6 of U514 develops an H level voltage during the F.F. and REW operations.
2. Q547 goes off during F.F. and REW operations, and Q548, Q549 go on supplying 20 V line voltage to the hot sides of both reel motors.
3. When the F.F. button is pushed, the H level voltage developed through pin 3 of U514 is applied to the base of Q543, turning it on, which in turn, makes Q544 go on. When Q544 goes on, 5 V is applied to the base of Q556 and Q557 through route 1 to enable the energizing of the right reel motor through its own drive circuit (Q556 and Q557).
4. At the same time, the base of Q560 and Q561 are also biased through route 2 to enable the energizing of the left reel motor through its drive circuit (Q560 and Q561).
5. As shown in the schematic diagram, the overall resistance of bias route 1 is lower than that of route 2, signifying that the right reel motor drive circuit is able to supply more current to the right motor. Consequently, the right reel motor rotates with higher torque than that of the left reel motor. The left reel motor is only driven to develop proper back tension torque.
6. When the REW button is pushed, the H level voltage is applied to the base of Q545 turning it on, followed by Q546. Then the manner which the bias current is applied above in the F.F. operation is reversed. The bias current is now applied to the base of Q556 through R659, R658, R656 and D522 while at the same time is fed to the base of Q560 through R657 and D523. This being the case, the left reel motor now rotates with higher torque than that of the right reel motor.

1-10. ELECTRICAL BRAKE SYSTEM

See Fig. 1-9

The electrical braking system functions when a fast operation mode is changed to any other mode and continues to function until the tape speed drops to a predetermined speed and the motion sensing circuit develops an L level signal. The case in which the mode is changed from REW to STOP is described below.

1. When the STOP button is depressed in the REW mode of operation, pin 13 of U519 goes LOW, then pin 12 of U513 goes LOW to make pins 11, 5 and 10 of U513 and pin 4 of U514 go HIGH. When pin 4 of U514 goes HIGH, pin 6 of U514 goes LOW and Q545 and Q546 are turned off.
2. While the logic state at pin 6 of U513 is set to HIGH by the H level output from the motion sensing circuit during REW mode of operation, pin 8 of U513 (and thus, pin 2 of U514) goes LOW when the STOP button is depressed. Then pin 3 of U514 goes H.
3. Thus, the mode of operation is temporarily changed from REW to F.F and electrical braking is applied to the reel motors to reduce tape speed rapidly.
4. When tape speed has been considerably reduced by applying the electrical brake to the reel motors, the motion sensing circuit outputs an L level signal to the reset terminal (pin 1 of U513) and the flip-flop output (pin 6 of U513) goes L; then, pin 8 of U513 goes H and pin 3 of U514 goes L. Thus, both pins 3 and 6 of U514 are set to L (pin 6 of U514 is set to L when the REW mode is changed to the F.F mode).
5. When pin 3 of U514 goes L, Q541 base bias is cut, and Q541 and Q542 go off to disconnect the ground side of the brake solenoid and apply mechanical braking to the reel motors.

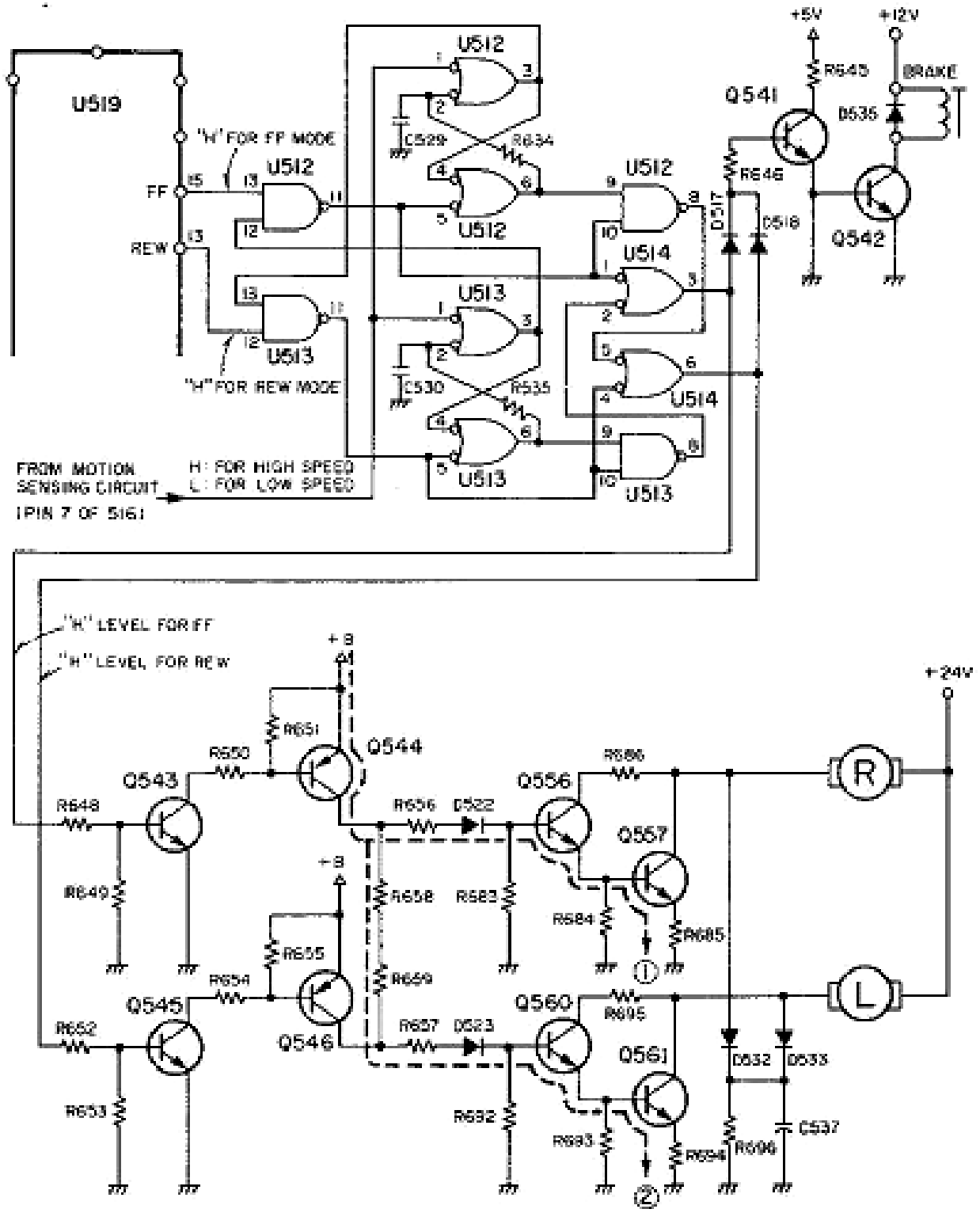

Fig. 1-9. FF and REW Mode Operation Control Circuits

1-11. COUNTER ZERO RETURN

See Fig. 1-10.

If ZERO RETURN switch S609 is set to ON, the tape stops automatically when the electronic counter reading reaches zero during the REW mode of operation. The electronic counter is designed to produce one H level pulse when its reading reaches zero. The zero return operation functions as follows:

1. When the REW mode is set, an H level voltage is applied to the base of Q509 to turn it on. Thus, pin 11 of U510, pin 10 of U510, and pin 12 of U506 are set to H. While the tape is running at high speed, the motion sensing circuit also outputs an H level signal, which is applied to pin 5 of U507 and pin 5 of U509. While in the REW mode, the electronic counter is decremented and, when it reaches zero, it generates one H level pulse. This pulse is applied to the base of Q507 to turn it on, which in turn makes pin 6 of U506 HIGH; this HIGH pulse is applied to pin 13 of U506. Since pin 12 of U506 has already been set to H, pin 11 of U506 goes L, then pin 8 of U506 goes H to turn on Q510. As Q510 collector is connected in parallel to the F.F button, the tape deck operation mode is changed from REW to F.F mode electronically.
2. When pin 11 of U506 goes L, the flip-flop is set, pin 3 of U507 goes H, pin 6 of U507 goes L, then pin 8 of U507 goes H and pin 12 of U507 is set to H.
3. When tape deck operation mode changes from REW to F.F, the electro-magnetic braking system starts to function but the tape does not stop immediately because of high rotational inertia and the tape counter continues to be decremented. When the inertia decreases the tape stops, then starts to run in the forward direction (the F.F mode is set at this time).
4. When the F.F mode is set, an H level signal is applied to the base of Q508 to turn it on, then pin 3 of U508 (pin 12 of U508) goes H. Now the tape counter is being incremented and, when the reading reaches zero, the counter outputs one H level pulse. This pulse is applied to pin 13 of U508 to make pin 11 of U508 go L. Pin 8 of U508 then goes H to set pin 13 of U507 to H. As pin 12 of U507 has already been set to H, pin 11 of U507 goes L and pin 6 of U508 goes H, turning Q511 on or changing the tape deck operation mode from F.F to REW.
5. On the other hand, when pin 11 of U507 goes L the flip-flop consisting of two U509 units is set and pin 3 of U509 is set to H and pin 6 of the same is set to L.
6. When the REW mode is set, pin 11 of U510 goes H again and pin 10 of U510 is set to H. Now the counter is being decremented and, when it reaches zero, one pulse is generated and applied to pin 9 of U510. Pin 8 of U510 then goes L, pin 3 of U510 goes H, and pin 8 of U509 goes L.
7. Meanwhile, when pin 3 of U511 is set to L (as started below), pin 6 of U510 goes H to turn on Q512, which in turn closes the STOP mode switch. Thus, the tape is stopped at a gradually decreasing speed when the counter reaches zero.
8. However, when the position in which the tape is to be stopped is within 3 or 4 seconds of that at which the REW mode is set, the tape can be directly stopped without repeating the REW/F.F./REW/STOP operation described above. This operation is conducted as follows: When the rewind mode is set, an H level signal is applied to C542 and a differentiated impulse is applied to the base of Q561 to turn it on, decreasing voltage at pin 2 of U515 and setting pin 1 of U515 to H for 3 ~ 4 seconds. When the tape counter reaches zero within this period, its zero pulse is applied to pin 2 of U511, setting pin 3 of U511 to L, causing pin 6 of U510 to go HIGH and to turn Q512 on. Thus, the REW mode is changed directly to the STOP mode if the counter zero pulse is generated within 3 ~ 4 seconds after the REW mode is set.

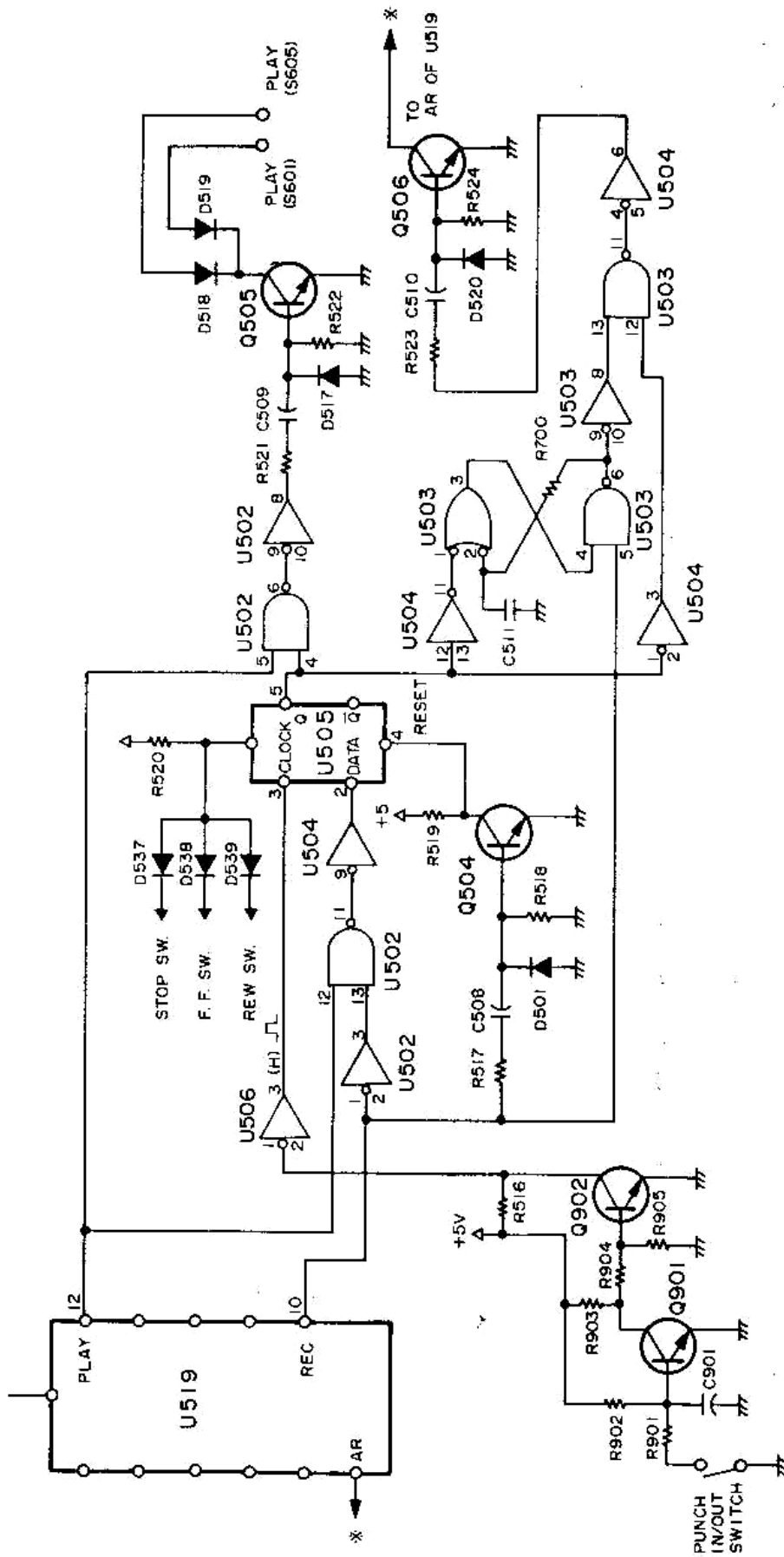

Fig. 1-11. Punch In/Out Control Circuit

1-13. EDIT CONTROL CIRCUIT

See control section of the inserted circuit diagrams.

1. When the EDIT switch is on, Q509 and Q510 go on, followed by Q512. With Q512 turned on, the Q813 base bias circuit on PCB assembly power supply is closed and Q813 supplies DC power to the capstan motor circuit to actuate the motor. At the same time, Q511 also goes on to turn off Q514 to release the STOP mode.
2. At the same time, when Q509 goes on, Q556, and Q558 are grounded through D528, D527, D529 and through the collector-emitter path of Q509, to stop the take-up reel motor.
3. During the EDIT mode of operation, no FF or REW mode is available because the FF IN and REW IN circuits are opened by the EDIT switch being set on.

1-14. REC AND PLAY MUTE SIGNALS

See Fig. 1-12.

1. REC signal
When the REC button is depressed, pin 10 of U519 outputs an H level signal, which is applied to the base of Q524 to turn it on. When Q524 goes on, Q525 base current flows and Q525 also goes on. The +24 V line is then connected to R579 for use as a control voltage to actuate amplifier circuits associated with recording.
2. Play Mute Signal
When the PLAY button is depressed, pin 12 of U519 outputs an H level signal, which is applied to the base of Q534 to turn it on, grounding the PLAY MUTE terminal. This low level state is also used to control the amplifier circuit (as described later). The CUE switch connected in parallel with Q534 serves the same function as the PLAY MUTE signal when it is closed.

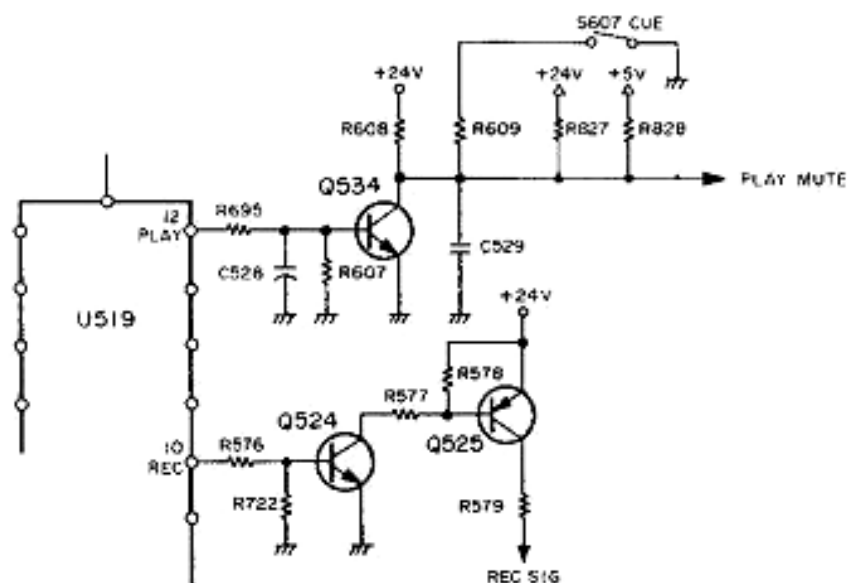

Fig. 1-12. Rec & Play Mute Circuit

1-15. DISPLAY CIRCUIT

See Fig. 1-13.

A. RECORD LED

1. The comparator of U515 with pins 5, 6, and 7 constitutes a square wave oscillator and outputs a pulse signal at pin 7. When the REC button is depressed, pin 9 of U511 is set to H and the pulse output is obtained at pin 8 of U511. The pulse signal is then fed to gate pin 5 of Q501. Meanwhile, as the REC button is on, pin 1 of U501 is set to H.
2. If one or more of the four record function switches are switched on, a L level signal is applied to R511 as the REC MODE signal, causing pin 11 of U511 (pin 2 of U501) to go H. Then, pin 3 of U501 (pin 4 of U501) goes L, setting pin 6 of U501 to H and turning Q501 on. Thus, the REC LED (D601) lights.
3. Next, assume that none of the four record

function switches are on; an H level signal is then applied to pins 12/13 of U511 through R514 so that pin 11 of U511 (pin 2 of U501) goes L. Since pin 1 of U501 is set to H, pin 3 of U501 (pin 4 of U501) goes H and the output gate (pin 6 of U501) opens. Then, the pulse signal applied to pin 5 of U501 is output from pin 6 of U501, turning Q501 on and off and making the REC LED flash to indicate that the tape deck is in the REC mode but that no recording channel is designated.

B. PAUSE LED

When the REC and the PAUSE buttons are on, pins 12 and 13 of U501 are set to H and an L level signal is output at pin 11 of U501. Then, pin 8 of U501 goes H, turning on Q502 and lighting PAUSE LED D602.

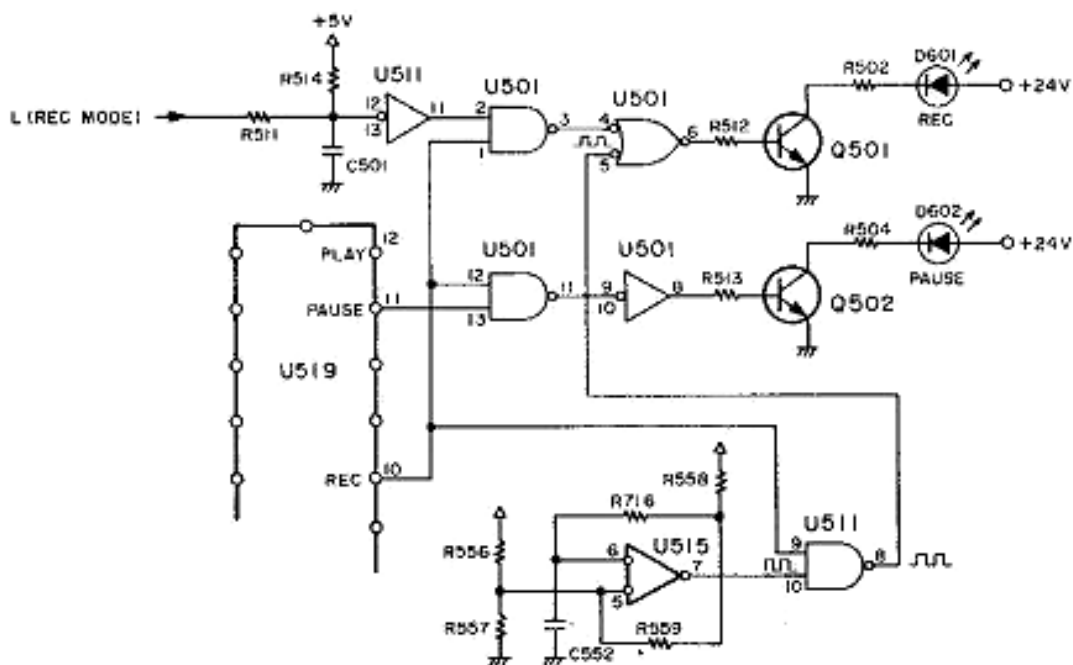

Fig. 1-13. Display Circuit

1-16. AMPLIFIER CIRCUIT DESCRIPTION

This description covers only one channel, with the exception of several switching circuits which are assembled on the FUNCTION PCB, MASTER OSC PCB, OUTPUT SELECT PCB, and LED indicators.

1-16-1. Power Muting Circuit

See Fig. 1-14.

K102 is a muting relay which protects the output line from impulse noise occurring when the power switch is turned on or off. When power supply starts, +6 V (VU meter lamp power) rises rapidly, charging C802 through R801. When the voltage across C802 reaches about 1.2 V, Q801 goes on and K102 operates to connect the OUTPUT terminal to the output circuit of the

OUTPUT amplifier. It takes about 3 seconds for K102 to go on after power supply starts. The power lines of the deck's amplifier reach a steady state during this time. Thus, the audio output line is protected from transient noise.

When the power is turned off, the +6 V applied to the VU meter lamp falls rapidly, and C802 quickly discharges through D805 and the meter lamp; Q801 and K102 go off immediately before the amplifier power line voltage falls. Thus, the output line is also protected from transient noise.

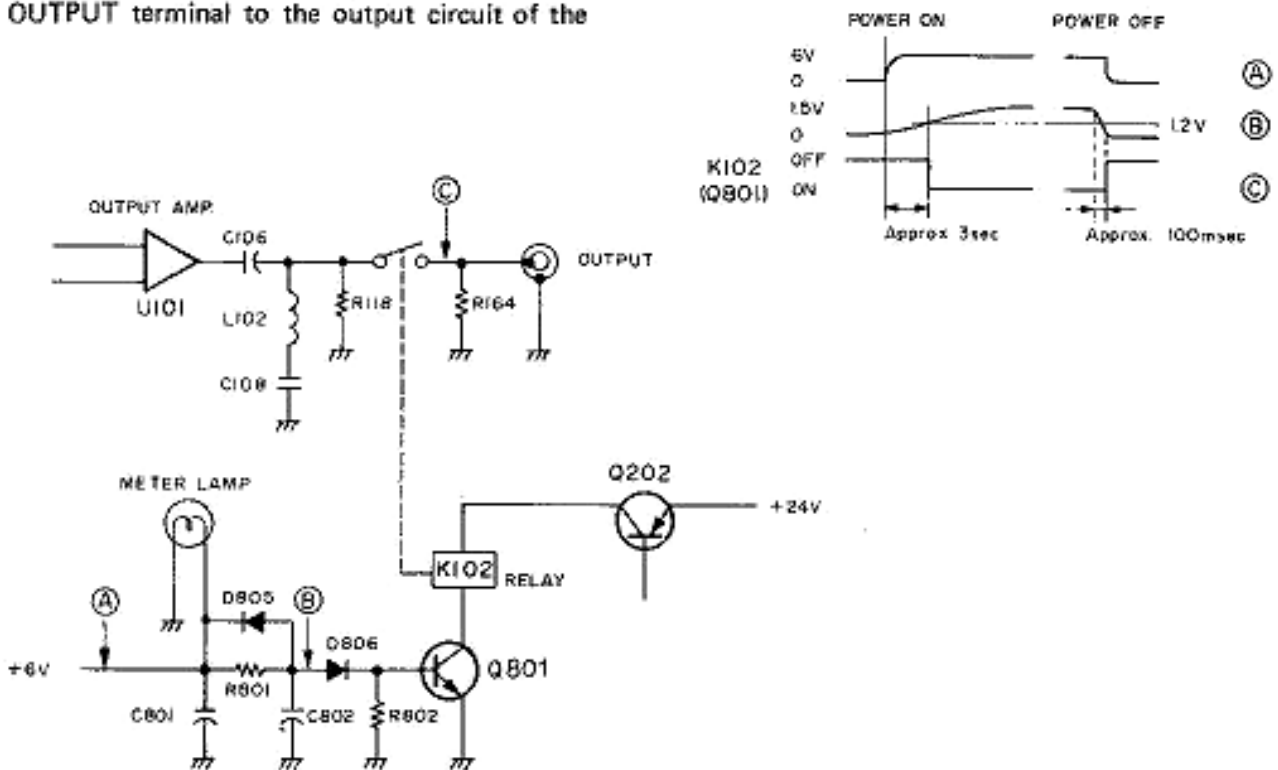

Fig. 1-14. Power Muting Circuit

1-16-2. Bias and Record Control Circuit

See Figs. 1-15(A) and 1-15(B).

1. As previously described, when the unit is in REC mode, REC SIG is produced at the Q525 collector. This signal is applied to the base of Q301 to turn it on; Q302 then also goes on, supplying +24 V to the FUNCTION (four channel) switches. If any one (or more) of the switches (for example F4) is set to ON

or into the record mode: (1) the common terminal of F4a is connected to the +24 V line and voltage is supplied to D109, D117 and D115. Thus, Q108, Q109 and Q120 go on, and Q118, Q119 also go on. (2) The F4b common terminal is grounded, making REC LED indicator light continuously as described in section 1-15 "Display Circuits".

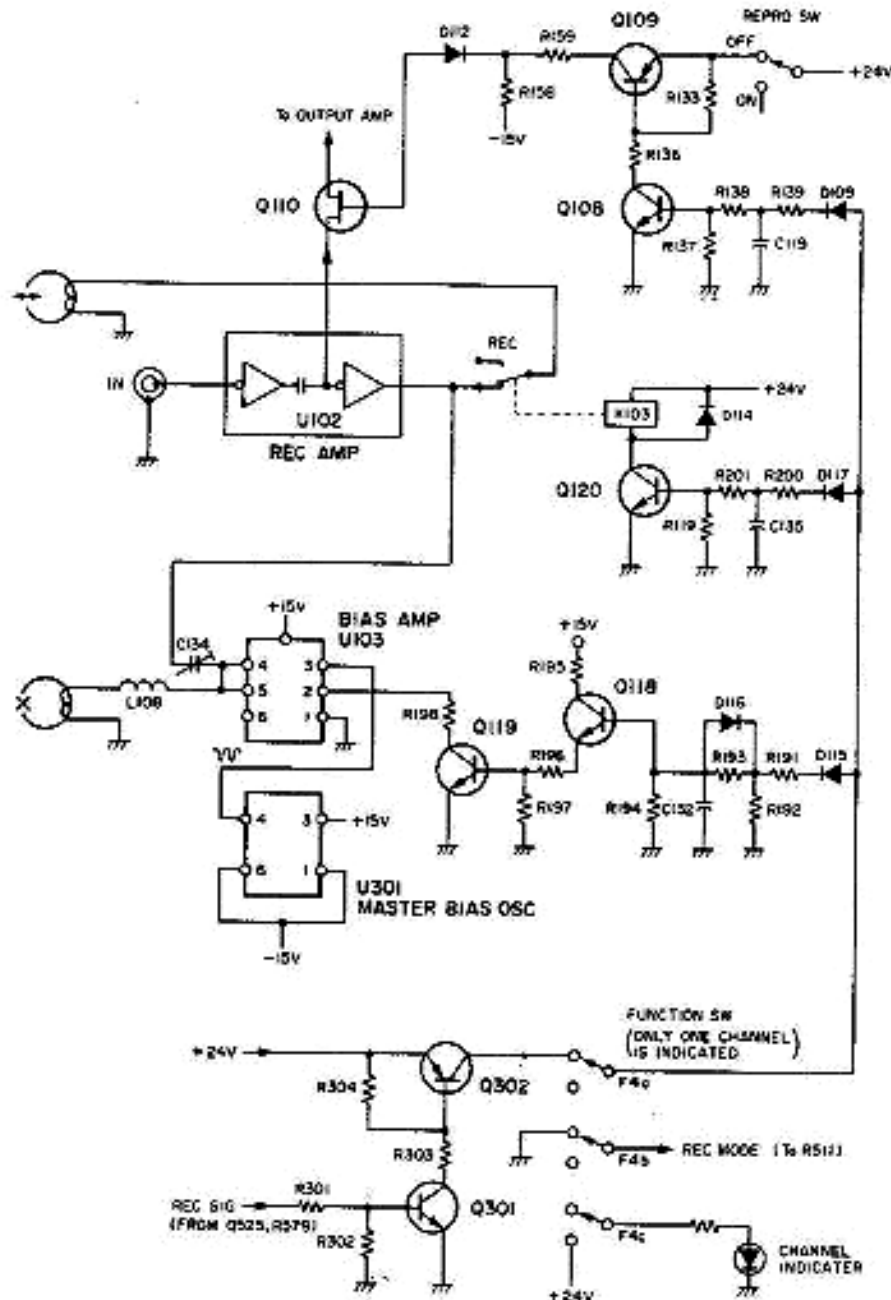

Fig. 1-15 (A). Bias and Record Control Circuit

(3) The F4c contact is closed and the channel indicator LED lights up.

- 2 When Q109 is turned on, FET switching transistor Q110 is on and part of the recording signal is applied to the OUTPUT amplifier, allowing recording to be monitored. When Q120 goes on, REC relay K103 is energized, the record head is switched to the record amplifier, and the cold side of the erase head is grounded. Thus recording is made. On the other hand, when Q119 goes on, bias oscillator amplifier unit U103 starts to amplify the bias signal supplied from master bias oscillator U301 and the amplified output

is supplied to both the record and erase heads.

3. The on and off switching timings for all above circuits (the bias switching circuit comprising Q118 & Q119, the REC relay switching circuits comprising Q120, and the OUTPUT (SYNC - INPUT) switching circuits comprising Q108 & Q109) are suitably fixed so that transient noise has no undesirable influence on recorded sound quality. The switching timings (delay time periods) of the circuits depend on the values of C132, C135 and C119, respectively. For details on the relationship between these, refer to Fig. 1-15(B).

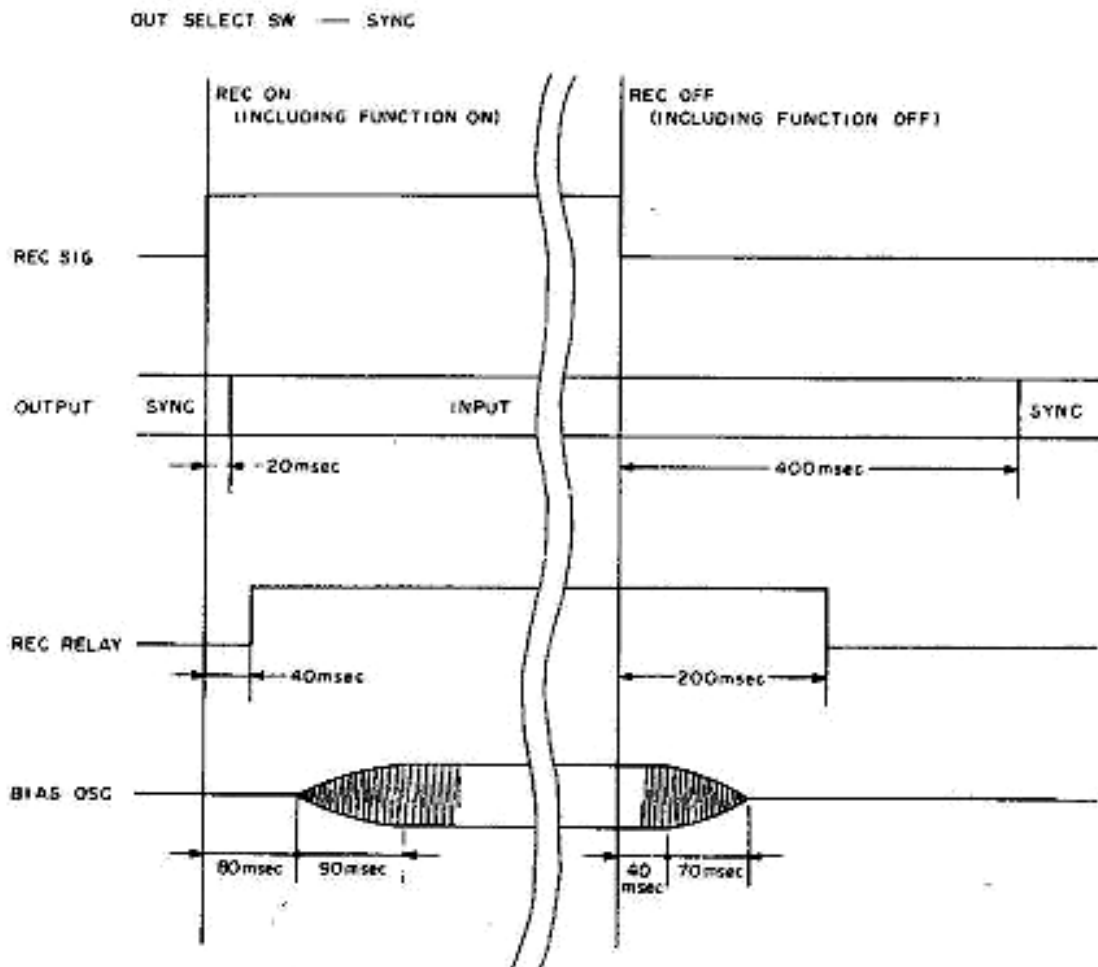

1-16-3 Reproduce Amplifier Circuit

See Fig. 1-16(A) and (B).

1. The reproduce amplifier consists of an 18 dB Step-up Transformer, a Reproduce EQ Amplifier, a Meter Amplifier and FET switching transistors which controls the function of the reproduce amplifier depending on the mode of operation and the tape speed selected.
2. Let's assume that the SPEED selector has been set to HIGH (15 ips - 38 cm/sec.) and that the play button is on.
3. When the INPUT (OUTPUT SELECT) switch is pushed, +24 V is applied to the base of Q201 through R251 and D204 so that Q201 goes on. When Q201 goes on, Q202 also goes on to supply +24 V to relay K102 and actuates it. The relay connects the amplifier output to the OUTPUT jack.
4. At the same time, +24 V is also applied from another INPUT switch contact to the cathode side of D112 through D118, R204 and R159, setting the gate potential of Q110 to zero; Q110 then goes on, connecting the input audio signals amplified by U102(1/2) to pin 3 of U101 (2/2) OUTPUT amplifier, the input circuit. Thus, the input signals are selected and amplified.
5. When the INPUT switch is reset to off, the voltage stored in C201 flows out through D201 turning off Q201, Q202 and when the REPRO switch is pushed, +24 V is supplied to C203 through R255 turning Q201, Q202 on. The relay K102 is actuated in the same way as in the INPUT mode.
6. Now assume that the SPEED selector has been set to HIGH and that OUTPUT SELECT is set to REPRO.
7. When OUTPUT SELECT is set to REPRO, +24 V is supplied through c1 of REPRO to the cathode side of D102 to set the gate potential of Q101 to zero, turning it on. Switching Q101 on allows the reproduced frequency response to be modified to precisely match the tape speed and the reproduce head which is to be used. During the low speed (7-1/2 ips - 19 cm/sec.), this modifying is done by Q102 being turned on.
8. Meanwhile, when OUTPUT SELECT has been set to REPRO, Q105 is turned on to connect the EQ amplifier output signals to the input terminal (pin 3) of U101(2/2) for final routing to the OUTPUT jack.

9. Then, because the play mode operation has been selected, the muting inhibit-signal (ca. -6.5 V) is applied to the gate of Q107 from pin 8 of the power supply unit PC board, which in turn, cuts off Q107. By Q107 being cut off, muting is inhibited and the audio signals are transmitted to the next stage.
10. When OUTPUT SELECT has been set to SYNC, Q204 is turned on and the SYNC RELAY K101 is energized. (This part of the circuit is not shown in Fig. 1-16(A)). When this relay is activated, the input pin of the primary side of the step-up transformer (T101), is disconnected from the reproduce head and is connected to one of the terminals of the REC relay circuit on the K103 side. Under this condition, the SYNC head will be

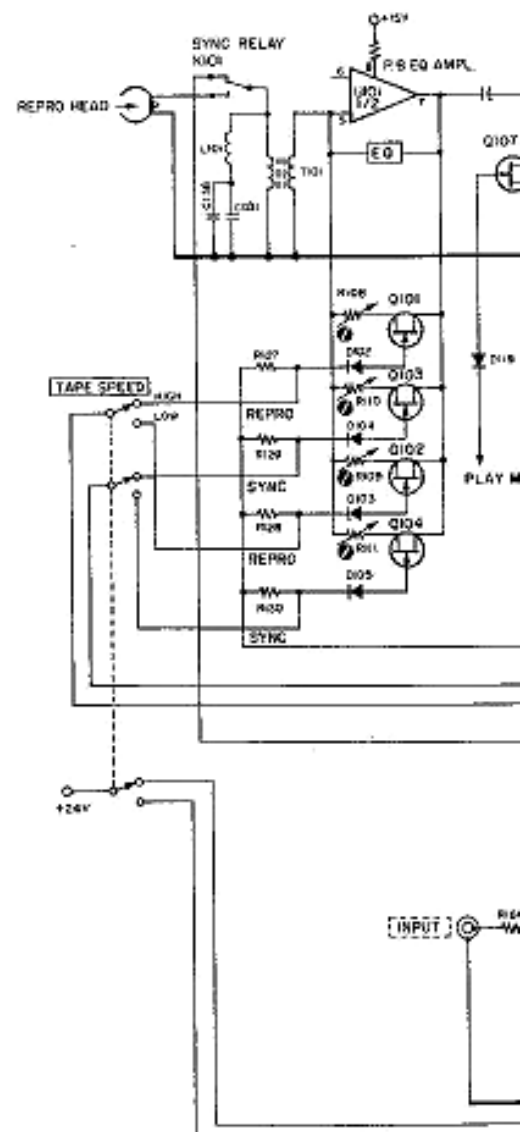

connected through K103 to the input terminal of the primary side of T101 and the audio signals which are picked up by the SYNC head are reproduced through the reproduce amplifier if the REC mode is not selected. However, if the REC mode is selected, the SYNC head will be connected through K103 to the record amplifier output circuit as described in "1-16-2 Bias and Record Control Circuit".

11. When the SPEED selector has been set to HIGH and OUTPUT SELECT is set to SYNC, +24 V is applied to the cathode side of D104 through b1 of the SYNC switch which sets the gate potential of Q103 to zero, turning it on. This allows the reproduced frequency response to be modified to precisely match

the tape speed and the reproduce head used. When the low speed is selected, Q104 is turned on to obtain this modifying and matching result in the same way.

12. When OUTPUT SELECT has been set to SYNC, Q106 is turned on and the reproduce EQ amplifier output signals are fed to pin 3 of U101 (2/2) to be finally outputted through OUTPUT.
13. In the SYNC mode of operation, one or more channels may be operated in the PLAY mode while the remaining channels are in the REC mode of operation. In this situation, the recording bias signal may flow into the adjacent channel head which are operating as reproduce heads and cause degrading of the sound quality (SN). To prevent this,

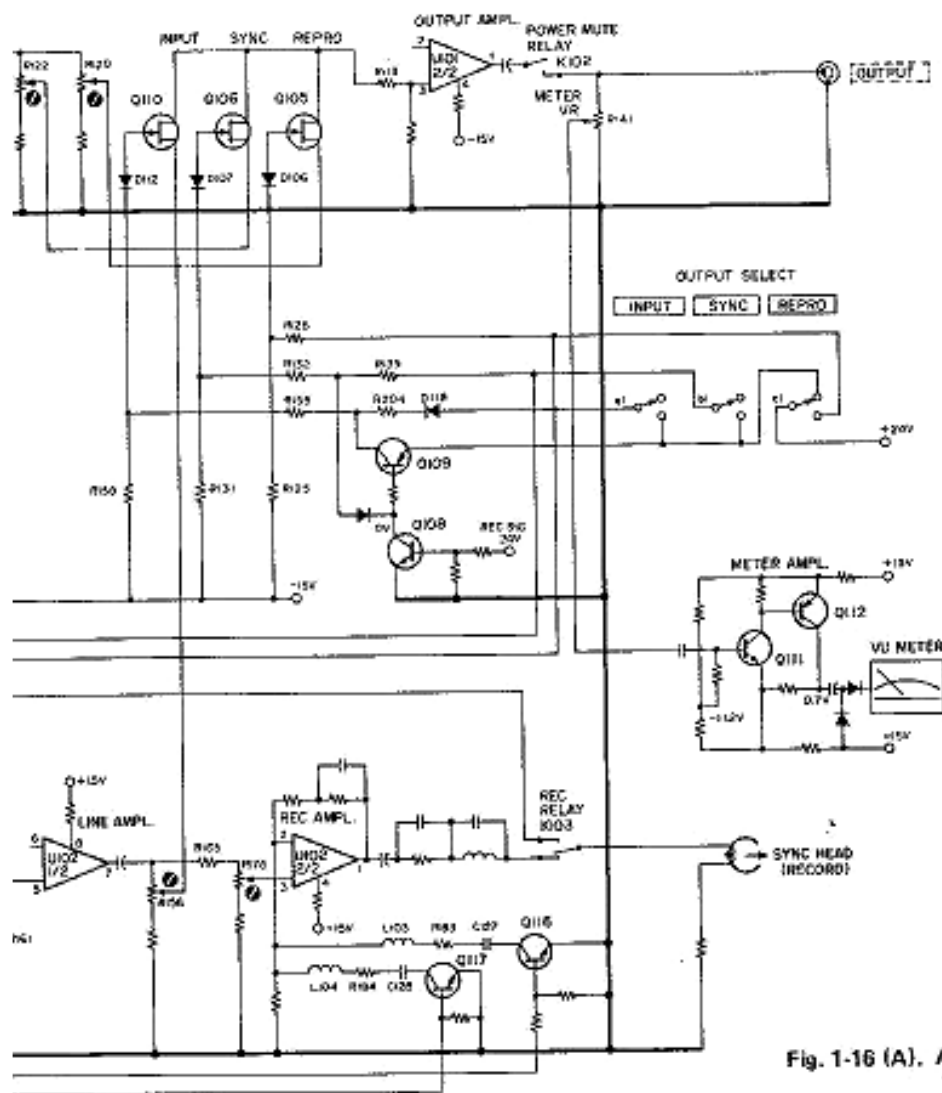

Fig. 1-16 (A). Amplifier Circuit Diagram

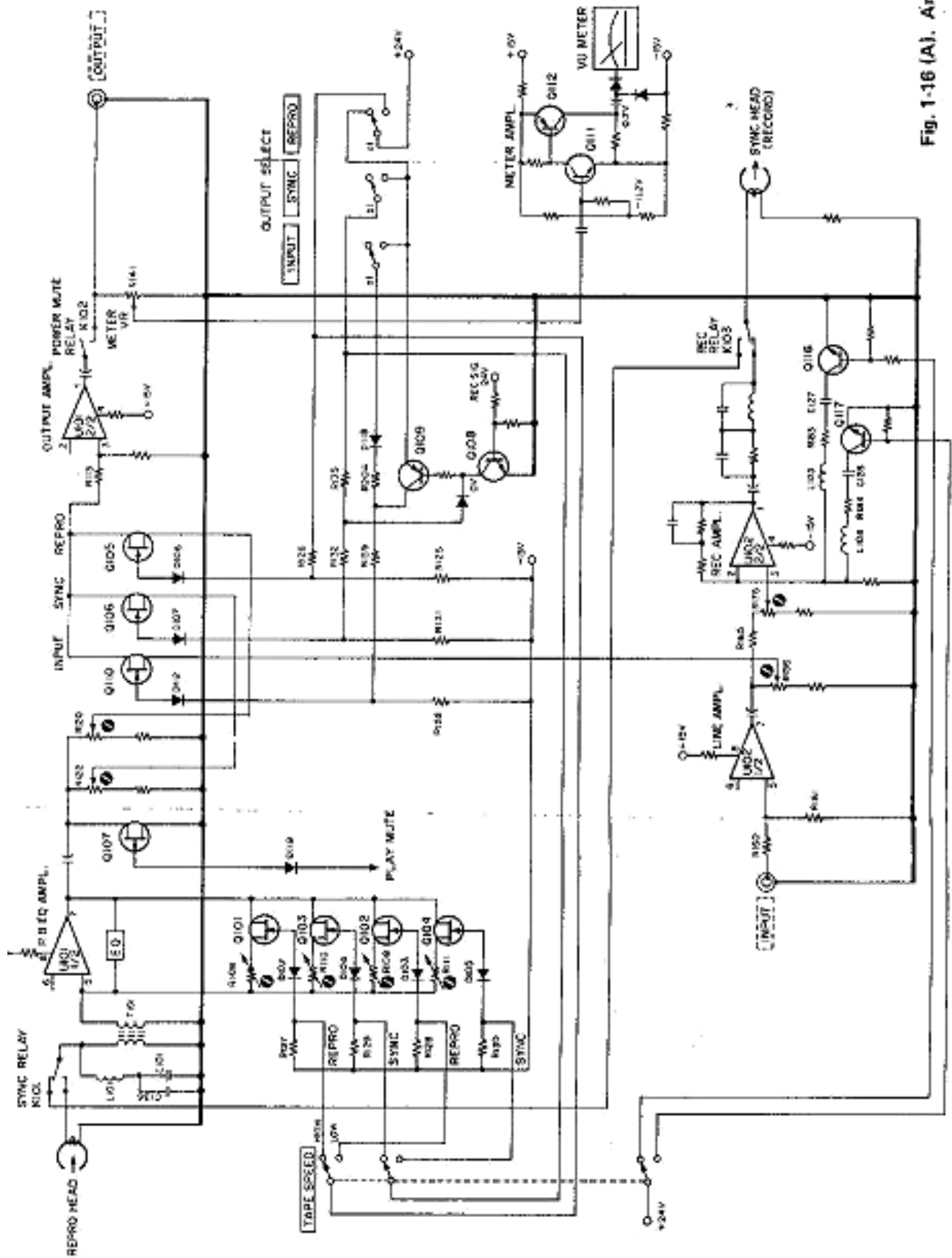

Fig. 1-16 (A). Am

three bias traps consisting of a choke coil and two capacitors (L101, C136, C101, etc.) are inserted into the amplifier circuit.

14. The on and off timings of the SYNC relay are adjusted so that each on or off operation is conducted during circuit muting to

prevent undesirable switching noise (as shown in Fig. 1-16.(B)). On and off timing of the SYNC relay depends on R260 and C208, and C208 and R261, respectively, in the SYNC relay drive circuit comprising Q203 and Q204.

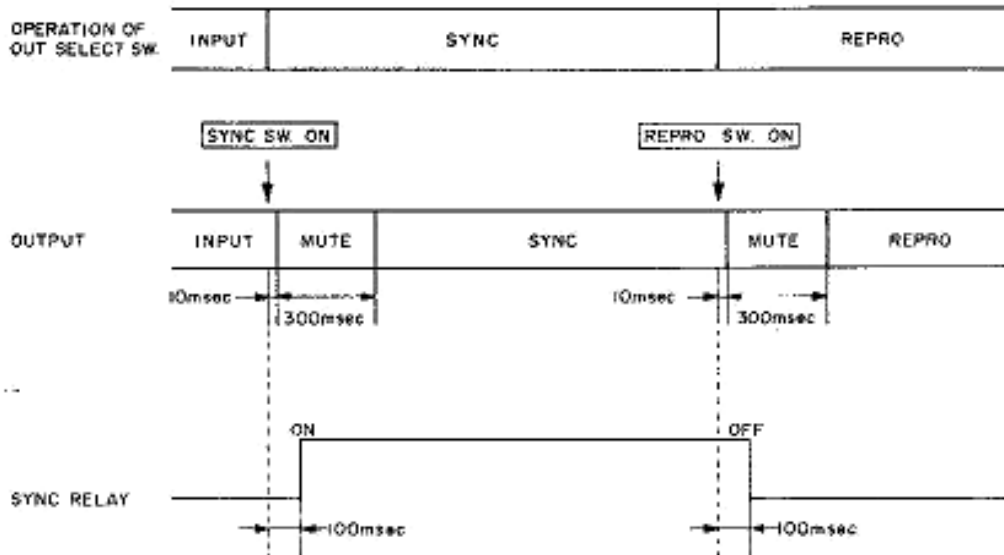

Fig. 1-16(B) SYNC Relay Operation Timing Chart

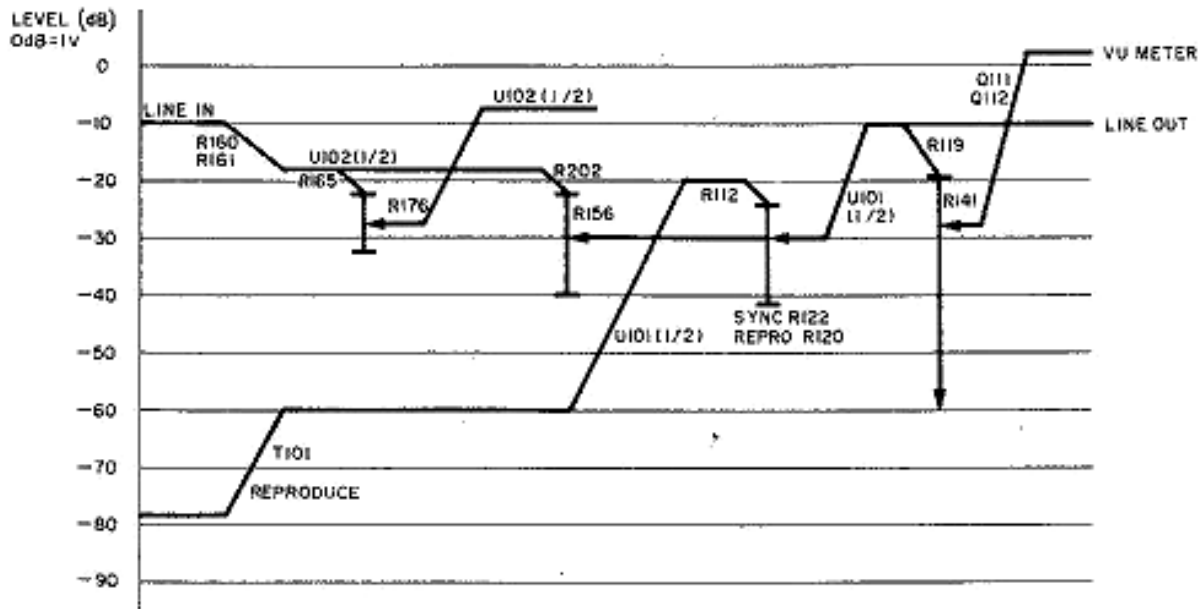

Fig. 1-17 Level Diagram

2. CHECKS AND ADJUSTMENTS

2-1. ESSENTIAL TEST EQUIPMENT REQUIRED

Wow & Flutter Meter	Meguro Denpa Sokki K.K., Model MK-668C (JAPAN), or Mincom Division, 3M Co., Model 8155 (U.S.A.)
Audio Oscillator	Hewlett Packard, Model 204C or equivalent
Digital Frequency Counter	Range: 10 Hz ~ 100 kHz; sensitivity; 0.1 Vrms; imp.: > 1 M Ω , < 25 pF
Band-Pass-Filter	1 kHz narrow band pass type
AF Level Meter	Range; -80 dB ~ +40 dB; imp.: > 1 M Ω , < 25 pF (example—HP 400GL)
Distortion Meter	General purpose (400 Hz, 1 kHz)
Oscilloscope	General purpose
Attenuator	General purpose
Tools	Spring scale: 0 ~ 8 lbs (0 ~ 4 kg) 0 ~ 2.2 lbs (0 ~ 1 kg) Hex head Allen wrenches, Plastic alignment tool
Cleaning fluid:	TEAC TZ-261 or equivalent TEAC Spindle Oil TZ-255 or equivalent
Head Demagnetizer	TEAC E-3 or equivalent
Test Tapes	Tape Speed/Wow-Flutter Test Tape TEAC YTT-2004 (for tape speed 15 ips) TEAC YTT-2003 (for tape speed 7-1/2 ips) Reproduce Alignment Test Tape TEAC YTT-1004 (for tape speed 15 ips, NAB Equalization 3180 + 50 μ sec.) TEAC YTT-1003 (for tape speed 7-1/2 ips, NAB Equalization 3180 + 50 μ sec.) Blank Test Tape (Recording) TEAC YTT-8063

2-2. REMOVING THE PANELS OF THE DECK

1. Dress Panels

- 1) Remove the left and right tension arm tape guides ① by turning the tape guide caps counterclockwise.
- 2) Turn the pinch roller cap ② counterclockwise to remove the pinch roller.
- 3) Remove the pitch control knob ③ with a 1.5 mm hex-head wrench and loosen to remove the nut directly behind it.
- 4) Remove the housing by loosening the two hex screws ④ with a 3 mm hex-head wrench.
- 5) Remove the eight hex screws ⑤ from both sides with a 2.5 mm hex-head wrench, and then remove the three screws ⑥ holding the dress panel. Remove the dress panel by pulling out in the direction of the bottom cover. To completely remove, disconnect the connector coupling the transport control assembly to the main assembly.

2. Rear Panel

- 1) Remove the seven ⑦ holding screws from the rear panel.

3. Bonnet Panel

- 1) After removing the rear panel, go on to removing the bonnet panel.
- 2) Remove the two screws ⑧ which are found inside the rear panel.
- 3) Remove the six screws ⑨ (both sides) holding the bonnet panel.

4. Bottom Panel

- 1) Remove the eight screws ⑩ from the feet attached to the bottom panel.
- 2) Remove the screw ⑪ holding the bottom panel.

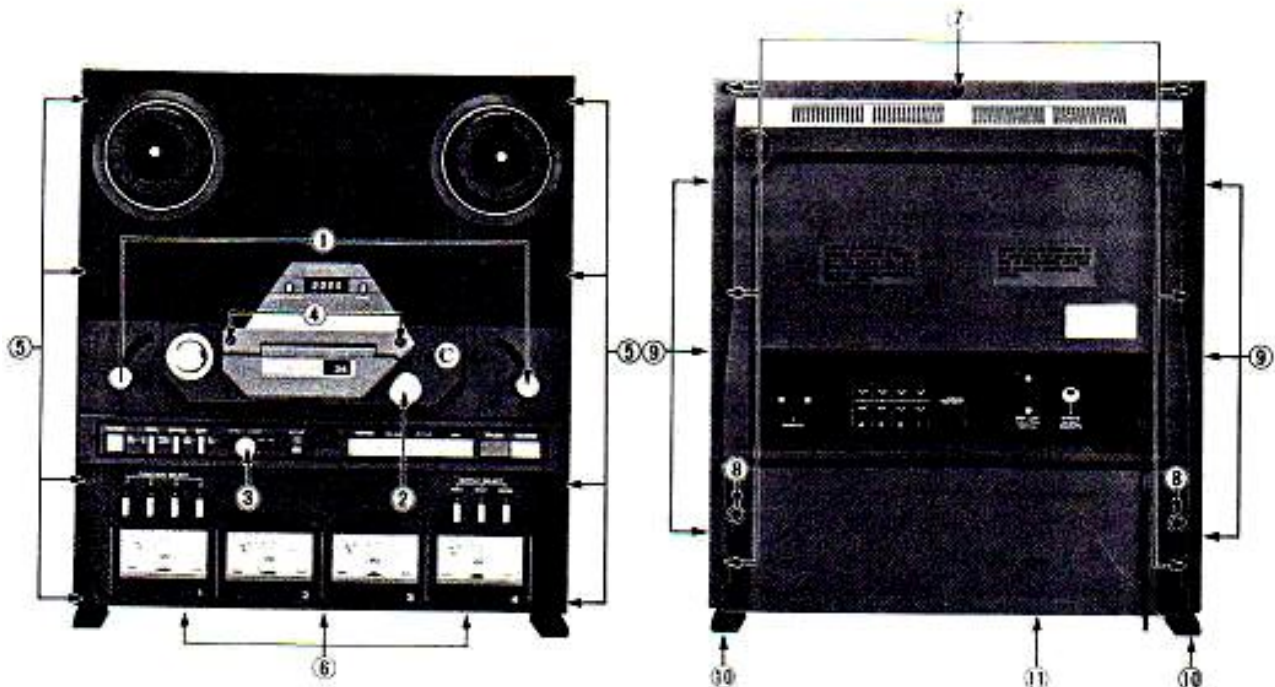

2-3. CAPSTAN THRUST CLEARANCE

1. There must be a clearance of 0.05 to 0.15 mm between the capstan shaft and the thrust plate. Check to see that the clearance is within this range. If not, loosen the two screws on the flywheel, adjust the clearance, and retighten the screws.

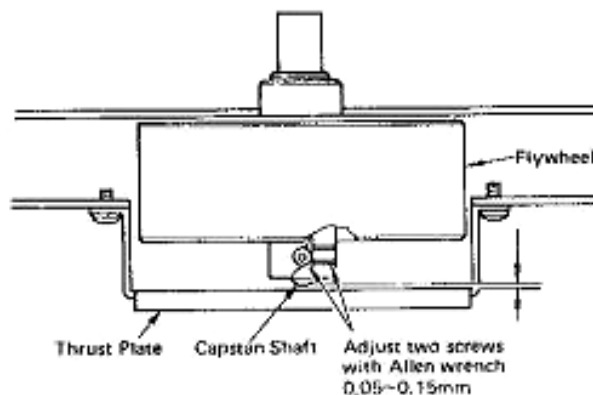

Fig. 2-1.

2-4. BRAKE MECHANISM

Note: Be sure that the power is turned off prior to making any adjustments to the brakes.

1. Screw (A) for the left brake (as viewed from the front) must be adjusted so that there is a clearance (a) of 1 mm between lever (C) and lever (E). Screw (A) for the right brake must then be adjusted so that lever (B) is parallel to lever (C). See Fig. 2-2.
2. When there is contact at (a), position the solenoid housing so that the gap at (f) (the distance between the plunger and solenoid washer) is 3 mm.

2-5. BRAKE TORQUE

Note: Before making any brake adjustments or measurements, make sure the power is off.

1. Mount an empty 7" reel onto either reel table and attach a spring scale to the reel with a string. See Fig. 2-3.
2. Smoothly pull the scale away from the reel under test and note the torque value when the reading on the scale is steady. The proper torque values are given in the chart on the next page.

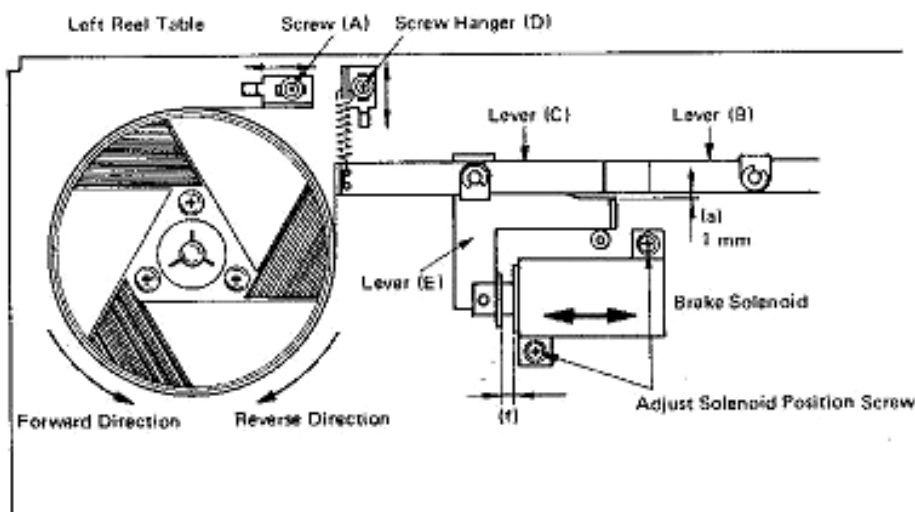

Fig. 2-2.

- Follow steps 1 and 2 for each measuring condition; i.e., (A) through (D) in Fig. 2-3.
- If the forward-direction torque is not correct, change the hooking position of the spring hanger (reference (D) in Fig. 2-2) for the corresponding brake requiring adjustment. If, after the forward-direction torque has been properly adjusted, the reverse-direction torque is not correct, or the forward-direction torque is still not correct, check to see if the brake felt pad is worn, and also check that the brake mechanism is properly aligned as explained in Section 2-4, "Brake Mechanism". If necessary, replace the entire reel table.

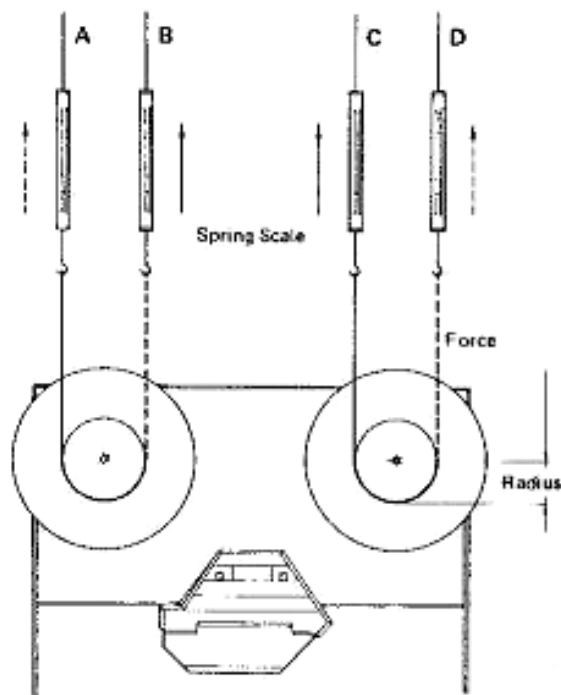

Fig. 2-3.

Forward direction (B) (C)	1700 – 2100 g-cm (23.6 – 29.2 oz-inch)
Reverse direction (A) (D) (Reference values)	650 – 800 g-cm (9.0 – 11.1 oz-inch)
Left/Right deviation	200 g-cm (2.78 oz-inch)

Torque calculating formulas:

- Torque (in g-cm or oz-inch)
= Force or Weight (in g or oz) x Radius (in cm or inch)
- Conversion of g-cm to oz-inch:
 $\text{g-cm} \times 0.0139 = \text{oz-inch}$

2-6. REEL MOTOR TORQUE

Note: *For torque calculation, refer to the said formulas.

*There is no specially-provided adjustment for take-up torque, so if correction is needed, repair or replace the defective part and/or circuit.

2-6-1 Take-up Torque

- Hold the right tension arm up with a rubber band.
- Mount an empty 7" reel onto the take-up (right) reel table, and attach a spring scale to the reel with a string.
- Place the deck in the reproduce mode.
- Allow the rotation of the reel to slowly pull the scale toward the reel.
- Hold the spring scale with enough force to allow steady reading. See Fig. 2-4.
- The calculated value should be approx:

REEL SW	TAKE-UP TENSION
LARGE	550 to 650 g-cm (7.64 to 9.03 oz-in)
SMALL	300 to 400 g-cm (4.17 to 5.55 oz-in)

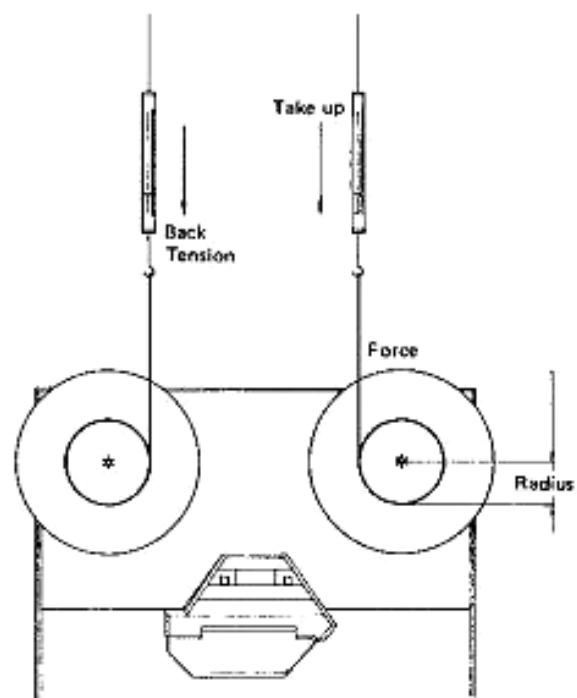

Fig. 2-4.

2-6-2 Back Tension

1. Hold the right tension arm up with a rubber band.
2. Mount an empty 7" reel onto the supply (left) reel table, and attach a spring scale to the reel with a string.
3. Place the deck in the reproduce mode.
4. Using a steady, smooth motion, pull against the motor torque to draw the scale away from the reel.
5. After making sure that the reel motion is smooth (the string should not be rubbing against the reel flanges), note the value indicated on the scale. See Fig. 2-4.
6. The calculated value should be approx:

REEL SW	BACK TENSION
LARGE	350 to 400 g-cm (4.86 to 5.55 oz-in)
SMALL	200 to 250 g-cm (2.78 to 3.47 oz-in)

2-7. PINCH ROLLER PRESSURE

Note: Pinch roller pressure is supplied by the pinch roller spring arm and it is most important that the solenoid plunger be fully bottomed before taking pressure measurement.

1. Hold the right tension arm up with a rubber band, string, etc.
2. Place the deck in the reproduce mode without threading the tape.
3. Attach a spring scale to the pinch roller as shown in Fig. 2-5.
4. Pull the pinch roller away from the capstan shaft (on a plane intersecting the center of the capstan shaft and the pinch roller) until the capstan shaft and the pinch roller are separated.
5. Ease pressure on the scale until the pinch roller just begins to turn. The scale should then be read 1.5 kg to 1.7 kg (3.3 lbs to 3.74 lbs).

With the plunger pushed in by hand until the pinch roller makes contact with the capstan shaft, the distance between the leftmost edge of the plunger and the leftmost edge of the solenoid housing is normally about 3 mm.

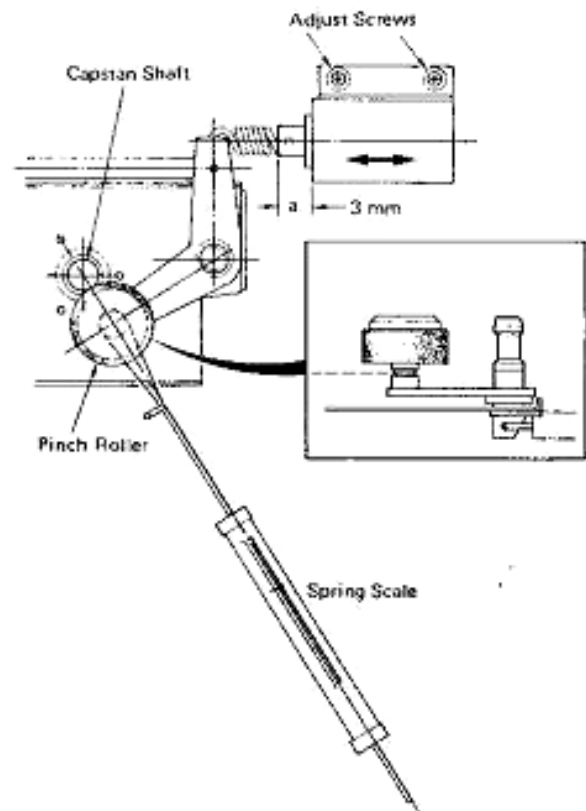
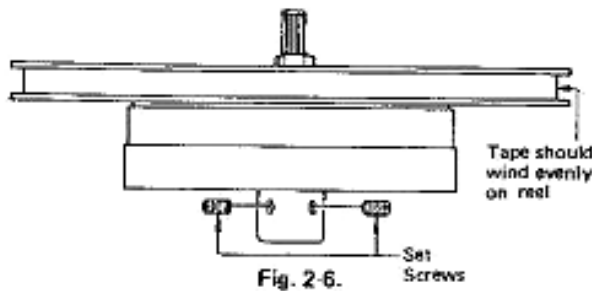

Fig. 2-5.

2-8. REEL TABLE HEIGHT ADJUSTMENT



Reel height adjustment is required only if a motor has been replaced or if tape rubs excessively against the reel flanges.

Adjustment is accomplished by loosening the reel set screws and moving the reel table on the motor shaft as shown in Fig. 2-6.

Remove the bonnet panel on the left or right of the unit for access to the set screws (2) in the reel motor shaft. Reel table should be adjusted using standard NAB 7" reels. With a tape loaded on the machine, position the reel table height for smooth tape travel. Be sure to tighten the set screws after each adjustment is made. Refer to page 78 (section 2-2).

2-9. TAPE SPEED

Tape speed is measured by using flutter test tape, which contain a highly accurate, continuous 3 kHz tone.

Test Tape: TEAC YTT-2004 (for tape speed 15 ips)
TEAC YTT-2003 (for tape speed 7-1/2 ips)

1. Connect a digital frequency counter to either OUTPUT.
2. The indicated frequency should be 3 kHz, $\pm 0.8\%$ for all speeds.
3. Play the middle of the test tape at high speed 15 ips (38 cm/sec) and adjust the HIGH speed trimmer resistor until the frequency counter indicates a reading of 3000 Hz. Use the LOW speed trimmer resistor for low speed adjustment 7-1/2 ips (19 cm/sec). See Fig. 2-7. (CAUTION: Use an insulated screwdriver to prevent shorting.)
4. Playing the tape at both the beginning and the end, check that the tape speed does not vary any more than the limits prescribed in the specifications, so that there is never a total deviation of more than $\pm 0.8\%$ Hz from the 3000 Hz test tone.
5. If tape speed is greatly offset from the specification, check pinch roller pressure and takeup

tension for correct values, and see that the tape path is clean.

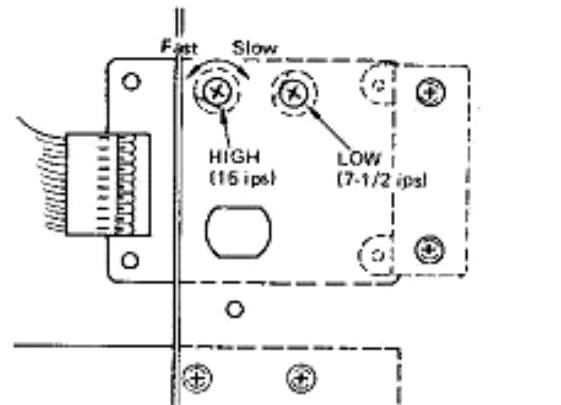

Fig. 2-7.

2-10. WOW AND FLUTTER CHECK (Reproduce Method)

1. Connect a Wow-and-Flutter Meter to the deck as shown in Fig. 2-8.
2. Playback the appropriate wow-and-flutter test tape.
3. If the peak or rms weighted value is to be read, set the Wow-and-Flutter Meter for the "Weighted" readings and also make sure that the meter is properly calibrated.
4. As the measured results may vary with respect to the location on the tape at which the measurement is taken, at least two locations – at the beginning and near the end of the tape – should be checked. There may also be slight differences in absolute values measured according to the brand of the meter being used.

Values should be as shown:

Tape speed	DIN/IEC/ANSI (peak value)		NAB (rms value)	
	Weighted	Unweighted	Weighted	Unweighted
HIGH	$\pm 0.06\%$	$\pm 0.09\%$	0.05%	0.07%
LOW	$\pm 0.09\%$	$\pm 0.12\%$	0.07%	0.09%

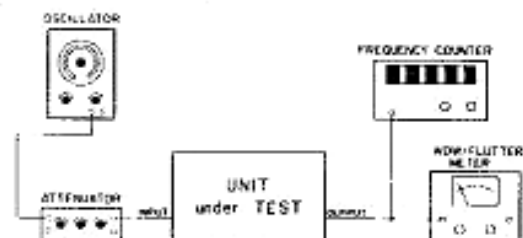

Fig. 2-8.

2-11. RECORD/REPRODUCE AMPLIFIER CHECKS AND ADJUSTMENTS

Preliminary Adjustments

- A. Before proceeding with any electrical performance checks or adjustments, make sure the tape transport mechanism has been completely aligned as mentioned in the preceding section, or at least make sure that the tape path and head contact are aligned correctly by the following methods:

TAPE PATH

1. Advance the tape in the play mode and check to see that the tape is not curled on the edges of the tape guide poles which are located on either side of the head assembly.
2. If curling at the left tape guide is evident, adjust the height of the guide by inserting a shim of appropriate thickness ($\phi 5 \times \phi 8 \times 0.5$ or 0.25) into "a" of the left tension arm. The same procedures should be followed for the right tension arm height adjustment. See Fig. 2-9.

HEAD CONTACT

1. Load a prerecorded tape with a constant level tone and reproduce at high speed 15 ips (38 cm/sec).
2. While observing the VU meter, temporarily increase back tension to the left reel by lightly applying pressure by hand. If sufficient contact pressure is applied to the head while the tape is running, no change will be noticed on the meter when back tension is increased. However, if insufficient pressure is applied to the head, the deflection needle will show increased deflection due to contact pressure caused by the back tension. This method will

help determine whether head contact is properly adjusted or not. To adjust, loosen the retaining nut (A) for that head (Shown in Fig. 2-12) and change the direction of the head for proper alignment.

Note: The amount of pressure to be applied to the reel is very important; too strong of pressure lowers the speed of the tape, while too light of pressure does not ensure contact. However, by practicing a few times, you will be able to judge approximate pressure to be applied.

HEAD AZIMUTH ADJUSTMENT

1. Connect the OUTPUT jack for channel L of the deck to the vertical input terminals of an oscilloscope.
2. Connect the OUTPUT jack for channel R of the deck to the horizontal input terminals for the oscilloscope.
3. Connect an AF level meter and a 50k ohm load to the OUTPUT jack(s) as shown in Fig. 2-10.

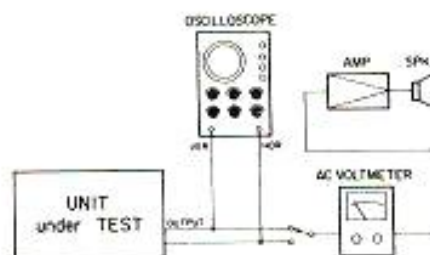

Fig. 2-10. Head Azimuth Test Set-Up

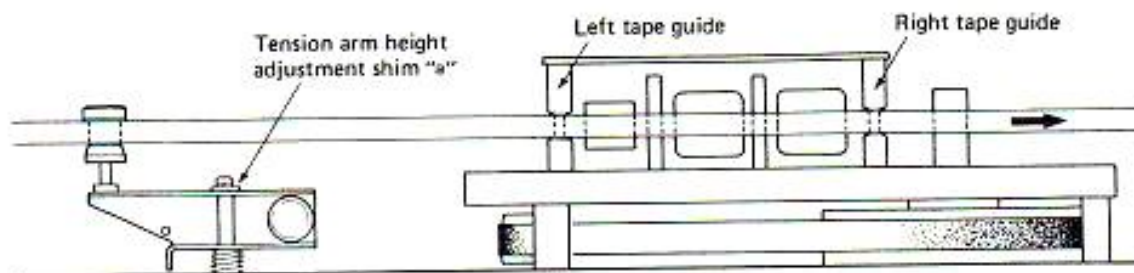

Fig. 2-9. Tape Path Adjustment

4. Switch OUTPUT SELECT to REPRO.
5. Load the reproduce alignment test tape to reproduce at high speed 15 ips (38 cm/sec). Then, a scope display reading showing phase relations between both channels will be obtained as shown in Fig. 2-11.
6. Adjust the REPRO head azimuth screw until the scope display shows less than 90 degree at 12.5 kHz out of phase with the AF level meter showing approximately maximum value for both channels.
7. Switch OUTPUT SELECT to SYNC, and adjust the RECORD SYNC head azimuth screw the same way.

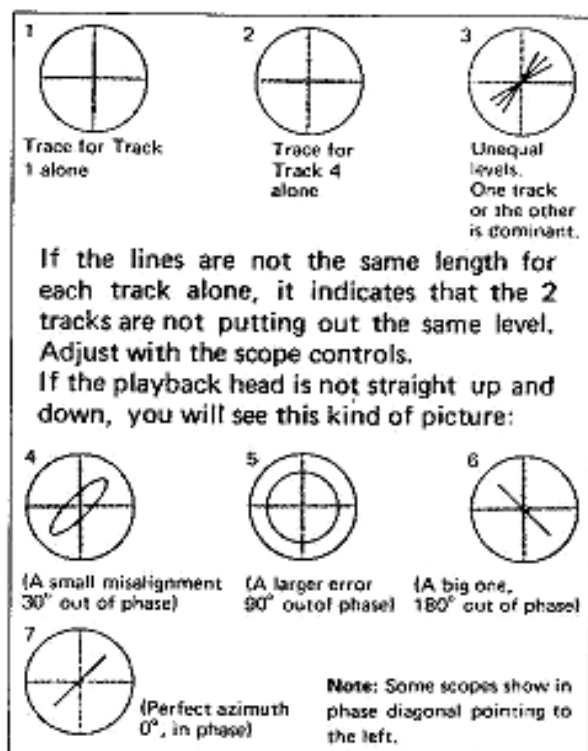

Fig. 2-11 Phase Shift

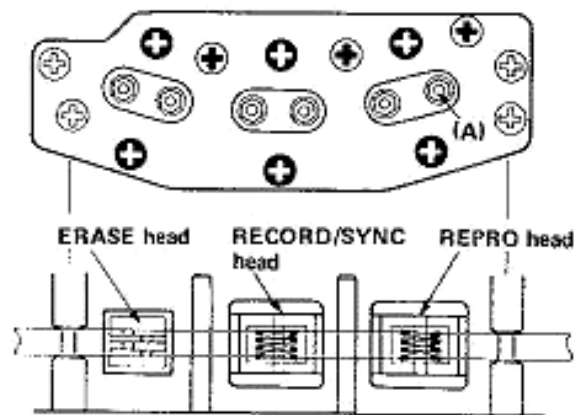

Fig. 2-12

- B. To get at the trim pots for record/reproduce amplifier circuit adjustments, remove the bottom cover by removing the holding screws. With the cover removed, you will see the amplifier boards to which the trim pots are mounted as shown in the photograph. The boards are identical and are exclusively used for their respective channels. See page 78. Record/reproduce amplifier checks and adjustments are given for only one of the channels but they should be applied for all other channels as well. Before beginning any adjustments, thoroughly demagnetize and clean the heads, tape guide, etc.
- C. Line Output Load Impedance of the Deck: This deck has been preadjusted and set for a 50k ohm load, when switched from this adjustment, for example, to a 10k ohm load, the output level results in a 0.5 dB reduction. When connecting less than a 50k ohm load, readjust the deck to match the applied load.

2-11-1 Input Level Calibration

1. Connect the test equipment as shown in Fig. 2-13.
2. Apply a 400 Hz, -10 dB (0.3 V) test signal to the INPUT jack on rear panel and switch OUTPUT SELECT to INPUT.
3. Make sure the AF level meter reads -10 dB (0.3 V) output. If it doesn't, adjust the R156 trim pot until the -10 dB indication on the level meter is obtained.

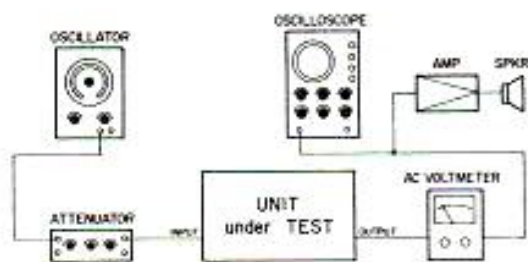

Fig. 2-13. Input Level Calibration

2-11-2 Meter Calibration

1. The meter is designed to indicate 0 VU when the reproduce amplifier produces -10 dB output into a 50k ohm load.
2. Therefore, make sure that the meter indicates 0 VU after completion of the above 2-11-1 (2-3) or after setting the input level to read -10 dB output. If the meter does not indicate 0 VU, adjust R141 to obtain the 0 VU indication.

2-11-3 Reproduce Level Calibration

1. Connect the AF level meter, (oscilloscope), and a 50k ohm load to the OUTPUT jack on the rear panel.
2. Switch OUTPUT SELECT to REPRO.
3. Load the reproduce alignment test tape for low speed 7-1/2 ips (19 cm/sec.) and reproduce at low speed. Observe the AF level meter, it should indicate -10 dB, if not, adjust the R120 trim pot to obtain the -10 dB output indication.
4. Switch OUTPUT SELECT to SYNC and reproduce the same tape. Check the AF level meter, it should read -10 dB. If not adjust the R122 trim pot.

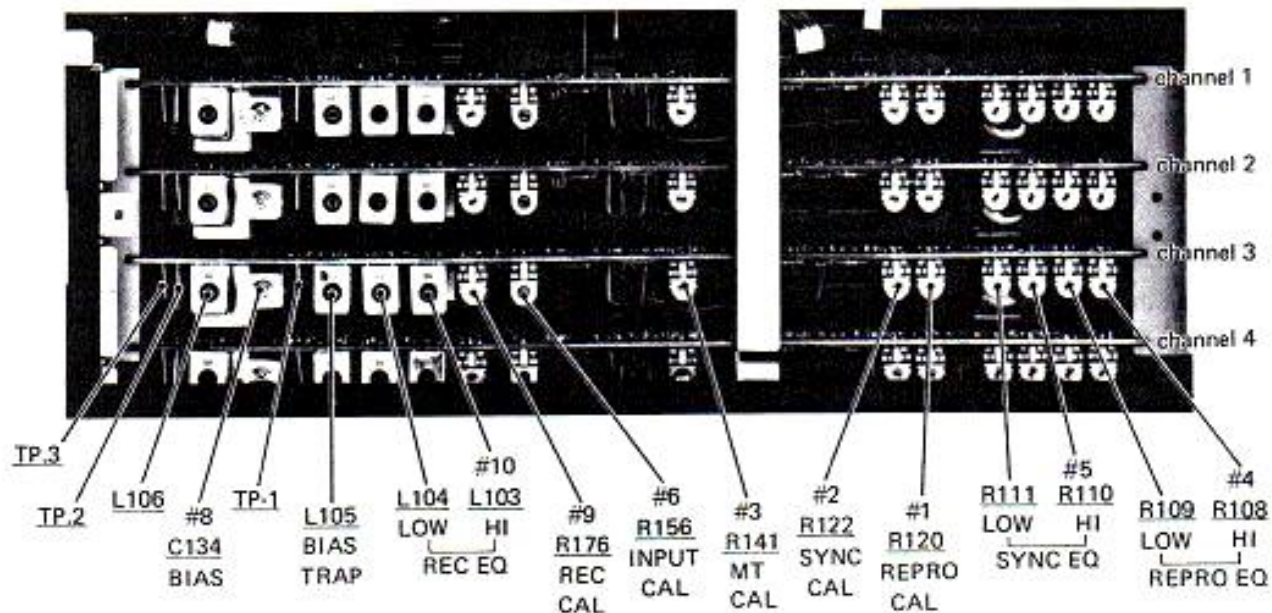

2-11-4 Reproduce Frequency Response

1. Connect the AF level meter, (oscilloscope), and a 50k ohm load to the OUTPUT jack.
2. Load the reproduce alignment test tape on to the tape deck.
3. Switch the OUTPUT SELECT to REPRO.
4. Reproduce the test tape and take a reading of the output levels at the specified frequencies shown in Fig. 2-14. They should be within the limit shown below. If not, adjust the REPRO EQ R108 for high speed and R109 for low speed.

YTT-1004 (High Speed 15 ips,
38 cm/sec.)

YTT-1003 (Low Speed 7-1/2 ips,
19 cm/sec.)

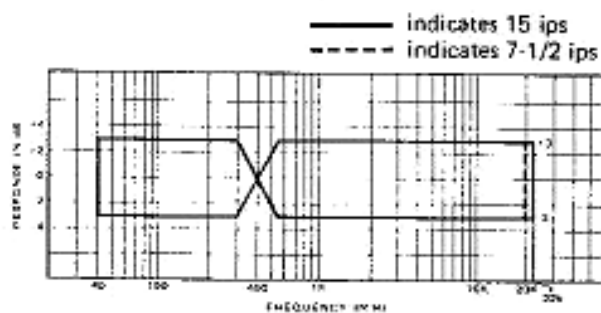

Fig. 2-14. Reproduce Frequency Response

5. Switch OUTPUT SELECT to SYNC.
6. Reproduce the same tape and also read the output levels the same way to learn whether the frequency response is within the above specified limit. If the frequency response is not within the specified limit, adjust the R110 for high speed and R111 for low speed.
7. If the specified frequency response cannot be obtained with the trim pot(s) adjusted;
 - * Check and compare the measurements of the other channels. If they stand up to spec, correct or replace the off spec channel record/reproduce amplifier PCB.
 - * If all channels are off spec, check power line, incorrect head adjustment, or whether heads should be cleaned.
 - * Demagnetize the heads.
 - * Finally, if all else fails, replace the heads.

2-11-5 Bias Tuning and Bias Trap Adjustments

These adjustments have been made at the factory and realignment will not be necessary except for the following circumstances:

- * When the SYNC head, ERASE head and/or Bias amplifier is replaced.
- * When the MASTER BIAS PC card or MASTER BIAS unit is replaced.

Use the following procedures to adjust.

A. BIAS TUNING

1. Place all channel FUNCTION switches to ON and set the tape deck into the REC PAUSE mode.
2. Connect a DC volt-meter between TP(2) and TP(3) by using an insulate screwdriver, adjust L106 to obtain a minimum reading on the DC meter. Be sure to use a non-conductive screwdriver (i.e. wood, plastic, etc.).

CAUTION: Do not try to obtain maximum reading on the DC volt-meter, which would occasion an extreme amount of Bias Amp output load.

B. BIAS TRAP

1. Connect an "AC" level meter between TP(1) and ground.
2. Place all the FUNCTION switches to ON and set the deck into the REC PAUSE mode.
3. Adjust L105 to obtain a minimum reading on the level meter.

2-11-6 Recording Bias Adjustment

This adjustment is made while you are recording a tone on the type of tape you'll be using for the session. It will be different for each brand of tape. Before proceeding with this adjustment, make sure that the tape path and head contact have been adjusted correctly as mentioned earlier and that no tape curling is noticed.

1. Connect an AF oscillator, oscilloscope, AF level meter (adjusted to 1 V range) and a 50k ohm load to the tape deck as shown in Fig. 2-13.
2. Adjust the AF oscillator to apply a 10 kHz, -10 dB (0.3 V, 0 VU) signal to the INPUT jack on rear panel.
3. Switch OUTPUT SELECT to REPRO and set all FUNCTION switches to ON.
4. Begin recording. Now adjustments can be made while recording a 10 kHz tone.
5. Begin adjustment by turning the trimmer C134 completely counterclockwise. Next, loosen and turn the trimmer clockwise and the AF level meter will rise to give peak reading. Slowly continue the clockwise rotation until the reading on the level meter drops 3 – 4 dB

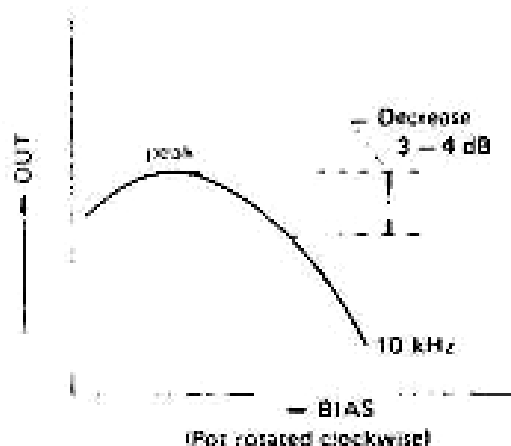

Fig. 2-15. Bias Level Adjustment

2-11-7 Recording Level Adjustment

Recording level adjustments should be done only after the reproduce level and recording bias have been properly set as specified above.

1. Connect the AF oscillator, oscilloscope, AF level meter, and a 50k ohm load to the tape deck as shown in Fig. 2-13.
2. Apply a 400 Hz, -10 dB (0.3 V) signal to the INPUT Jack.
3. Switch OUTPUT SELECT to REPRO and record the 400 Hz input signal at high speed on the specified recording test tape.
4. Check the AF level meter, it should indicate -10 dB (0.3 V). If not, adjust the R176 trim pot to obtain the -10 dB indication. At this time, make sure that the VU meter mounted on the front panel indicates 0 VU.
5. Switch OUTPUT SELECT to SYNC and record the 400 Hz input signal for a brief period of time. Then rewind the tape just recorded and reproduce it. Make sure that both the AF level meter and the VU meter indicate -10 dB and 0 VU, respectively.
6. If it's impossible to obtain a VU meter reading of 0 VU in steps 4 and 5 above, check to see whether the reproduce meter is set properly as described under 2-11-2. "Meter Calibration".

4. For a tape speed of 7-1/2 ips (19 cm/sec.), record and reproduce an input signal of 400 Hz, -20 dB (0.1 V), then change the frequency and check that the output is still within specification.

If not, adjust REC EQ coils L104 using a frequency higher than 20 kHz.

Blank test tape: YTT-8063

5. Switch OUTPUT SELECT to SYNC and record the test signals the same as above. When the recording is finished, rewind the tape just recorded and reproduce it. Measure the reproduced output levels at the proper test frequencies, and make sure that the frequency response is within the specified limit shown.
6. If the specified frequency response cannot be obtained with the trim pot(s) adjust, readjust the Bias Level Setting within its specified range by referring to 2-11-6 "Recording Bias Adjustment". If the bias level is readjusted, the recording level adjustment will be upset, so repeat the recording level adjustment again as described in 2-11-7 "Recording Level Adjustment".

2-11-8 Frequency Response (OVERALL)

After completion of the Recording Level Check and Adjustment, proceed to the Overall Frequency Response Check.

1. Connect the test equipment to the tape deck as shown in Fig. 2-13 and load a blank test tape onto the tape deck.
2. Apply a -10 dB test signal to the INPUT jack on the rear panel.
3. Switch OUTPUT SELECT to REPRO, record and reproduce an input signal of 400 Hz, -10 dB (0.3 V) at 15 ips (38 cm/sec.), then change the frequency and check that the output is still within specification.
If not, adjust REC EQ coils L103 using a frequency higher than 22 kHz.

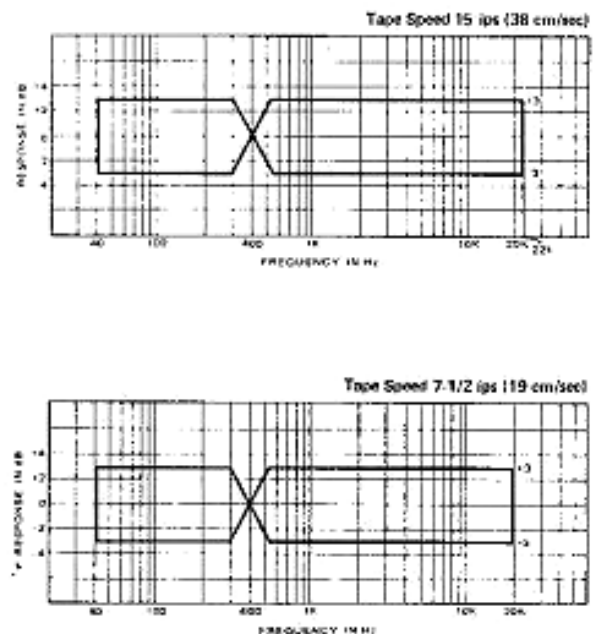

Fig. 2-16 Overall Frequency Response

2-11-9 Signal-to-Noise Ratio (OVERALL)

Prior to measurement, demagnetize all heads and tape guides.

1. Connect test equipment as shown in Fig. 2-13.
2. Apply a 400 Hz -10 dB (0.3 V = 0 VU) input signal to the INPUT jack on the rear panel.
3. Switch OUTPUT SELECT to SYNC and record a short length of the input signal at high speed, or low speed, then, while still in the recording mode, unplug the AF oscillator connected to the INPUT jack, and make another length of no-signal recording.
4. Rewind the recording made in step 3 (above) to the beginning and reproduce.
5. While making sure the reproduce output of the previously recorded 400 Hz 0 VU signal is -10 dB, raise the sensitivity of the AF level meter and measure the level of the no-signal portion of the tape.
6. With -10 dB (0 VU) as the reference level, the SN (signal-to-noise) ratio, as measured by the AF level meter, should be better than 50 dB at high speed or low speed.
7. If it is off spec,
 - * Check and compare the measurement of the other channels. If they stand up to spec, correct or replace the off spec channel record/reproduce amplifier PCB.
 - * Demagnetize the heads.
 - * Check erasure, refer to item 2-11-10.
 - * Check for proper adjustment of the bias trap.
 - * Try another tape of the same type number.

2-11-10 Erase Ratio

1. Connect test equipment to the tape deck as shown in Fig. 2-17.
2. Use a 1 kHz bandpass filter to check the erasing ratio.
3. Switch OUTPUT SELECT to SYNC and record at high speed a short length of the 1 kHz, 0 dB (1 V) signal and unplug the AF oscillator connected to the INPUT jack on rear panel.
4. Rewind the tape to the beginning of the recorded section.
5. Record a no-signal portion over the recording of the 1 kHz signal.
6. Measure the difference between the 1 kHz signal level and the no-signal portion. The difference should be at least 65 dB.
7. If the level difference is below this specification, check erase head output voltage for 60 – 70 V using an AC volt-meter.

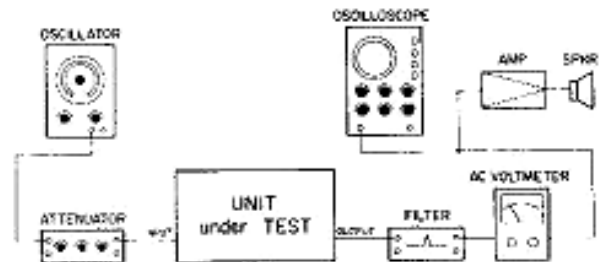

Fig. 2-17. Erase Ratio Test Set-Up

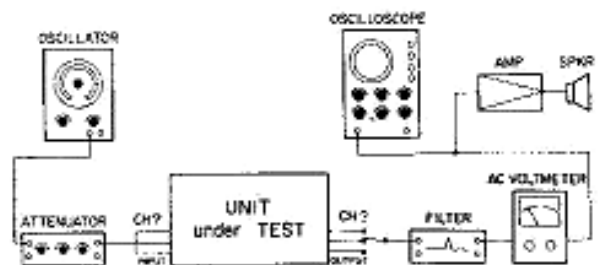

Fig. 2-18. Crosstalk Measurement Set-Up

2-11-11 Adjacent Channel Crosstalk

1. Connect test equipment as shown in Fig. 2-18.
2. While performing "no signal" recordings on one of the channels, apply a 1 kHz -10 dB (0.3 V) test signal to the adjacent channel.
3. Rewind the tape to the beginning of the recording.
4. Reproduce the tape with SYNC (OUTPUT SELECT) button depressed, after which, measure the output of the "no signal" recorded channel.
5. Measure the output of the adjacent channel. The difference should be 50 dB or greater.

2-11-12 Distortion

1. Connect test equipment as shown in Fig. 2-19.
2. Switch OUTPUT SELECT to REPRO.

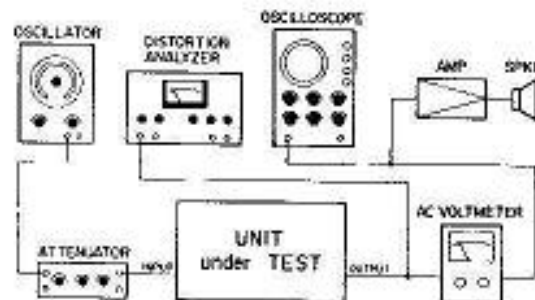

Fig. 2-19. Distortion Measurement Set-Up

3. Apply a 1 kHz, -10 dB (0.3 V) test signal to the INPUT jack and reproduce at high speed. Measure distortion of the reproduced output with a distortion analyzer connected to the OUTPUT jack.
4. Stop the recording and switch OUTPUT SELECT to SYNC.
5. Rewind the tape to its beginning and reproduce. Measure the distortion of the sections, which were recorded with the input signal levels of -10 dB.
6. The distortion measured should be less than 0.8.
7. If the distortion is off spec;
 - * Check and compare the measurements of the other channels. If they are off spec, correct or replace the off spec channel record/reproduce amplifier PCB.
 - * Check bias level setting and readjust if necessary.
 - * Demagnetize the heads.
 - * Replace the heads.