



SERVICE MANUAL

MODEL TYPE: YS1042
U15P

WEB ACCESS: <http://www.yorkville.com>

WORLD HEADQUARTERS CANADA

Yorkville Sound
550 Granite Court
Pickering, Ontario
L1W-3Y8 CANADA

Voice: (905) 837-8481
Fax: (905) 837-8746

U.S.A.

Yorkville Sound Inc.
4625 Witmer Industrial Estate
Niagara Falls, New York
14305 USA

Voice: (716) 297-2920
Fax: (716) 297-3689



Quality and Innovation Since 1963
Printed in Canada

IMPORTANT SAFETY INSTRUCTIONS



INSTRUCTIONS PERTAINING TO A RISK OF FIRE, ELECTRIC SHOCK, OR INJURY TO PERSONS

INSTRUCTIONS RELATIVES AU RISQUE DE FEU, CHOC ÉLECTRIQUE, OU BLESSURES AUX PERSONNES

CAUTION:

TO REDUCE THE RISK OF ELECTRIC SHOCK, DO NOT REMOVE COVER (OR BACK).

NO USER SERVICEABLE PARTS INSIDE.

REFER SERVICING TO QUALIFIED SERVICE PERSONNEL.

AVIS:

AFIN DE REDUIRE LES RISQUE DE CHOC ELECTRIQUE, N'ENLEVEZ PAS LE COUVERT (OU LE PANNEAU ARRIERE)

NE CONTIENT AUCUNE PIECE REPARABLE PAR L'UTILISATEUR.

CONSULTEZ UN TECHNICIEN QUALIFIE POUR L'ENTRETIEN

Read Instructions

The Owner's Manual should be read and understood before operation of your unit. Please, save these instructions for future reference.

Packaging

Keep the box and packaging materials, in case the unit needs to be returned for service.

Warning

When using electric products, basic precautions should always be followed, including the following:

Power Sources

Your unit should be connected to a power source only of the voltage specified in the owners manual or as marked on the unit. This unit has a polarized plug. Do not use with an extension cord or receptacle unless the plug can be fully inserted. Precautions should be taken so that the grounding scheme on the unit is not defeated.

Hazards

Do not place this product on an unstable cart, stand, tripod, bracket or table. The product may fall, causing serious personal injury and serious damage to the product. Use only with cart, stand, tripod, bracket, or table recommended by the manufacturer or sold with the product. Follow the manufacturer's instructions when installing the product and use mounting accessories recommended by the manufacturer.

The apparatus should not be exposed to dripping or splashing water; no objects filled with liquids should be placed on the apparatus.

Terminals marked with the "lightning bolt" are hazardous live; the external wiring connected to these terminals require installation by an instructed person or the use of ready made leads or cords.

Ensure that proper ventilation is provided around the appliance.

No naked flame sources, such as lighted candles, should be placed on the apparatus.

Power Cord

The AC supply cord should be routed so that it is unlikely that it will be damaged. If the AC supply cord is damaged DO NOT OPERATE THE UNIT.

Service

The unit should be serviced only by qualified service personnel.

Veillez Lire le Manuel

Il contient des informations qui devraient être comprises avant l'opération de votre appareil. Conservez S.V.P. ces instructions pour consultations ultérieures.

Emballage

Conservez la boîte au cas où l'appareil devait être retourner pour réparation.

Attention:

Lors de l'utilisation de produits électrique, assurez-vous d'adhérer à des précautions de bases incluant celle qui suivent:

Alimentation

L'appareil ne doit être branché qu'à une source d'alimentation correspondant au voltage spécifié dans le manuel ou tel qu'indiqué sur l'appareil. Cet appareil est équipé d'une prise d'alimentation polarisée. Ne pas utiliser cet appareil avec un cordon de raccordement à moins qu'il soit possible d'insérer complètement les trois lames. Des précautions doivent être prises afin d'éviter que le système de mise à la terre de l'appareil ne soit désengagé.

Risque

Ne pas placer cet appareil sur un chariot, un support, un trépied ou une table instables. L'appareil pourrait tomber et blesser quelqu'un ou subir des dommages importants. Utiliser seulement un chariot, un support, un trépied ou une table recommandés par le fabricant ou vendus avec le produit. Suivre les instructions du fabricant pour installer l'appareil et utiliser les accessoires recommandés par le fabricant.

Il convient de ne pas placer sur l'appareil de sources de flammes nues, telles que des bougies allumées.

L'appareil ne doit pas être exposé à des égouttements d'eau ou des éclaboussures et qu'aucun objet rempli de liquide tel que des vases ne doit être placé sur l'appareil.

Assurez que l'appareil est fourni de la propre ventilation.

Les dispositifs marqués d'un symbole "d'éclair" sont des parties dangereuses au toucher et que les câblages extérieurs connectés à ces dispositifs de connection extérieure doivent être effectués par un opérateur formé ou en utilisant des cordons déjà préparés.

Cordon d'Alimentation

Évitez d'endommager le cordon d'alimentation. N'UTILISEZ PAS L'APPAREIL si le cordon d'alimentation est endommagé.

Service

Consultez un technicien qualifié pour l'entretien de votre appareil.

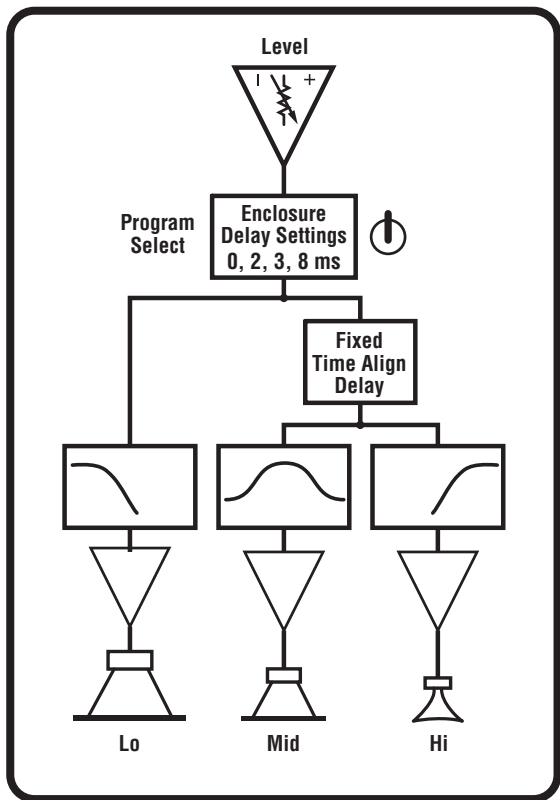

FROM INPUT BOARD

SIGNAL

GND

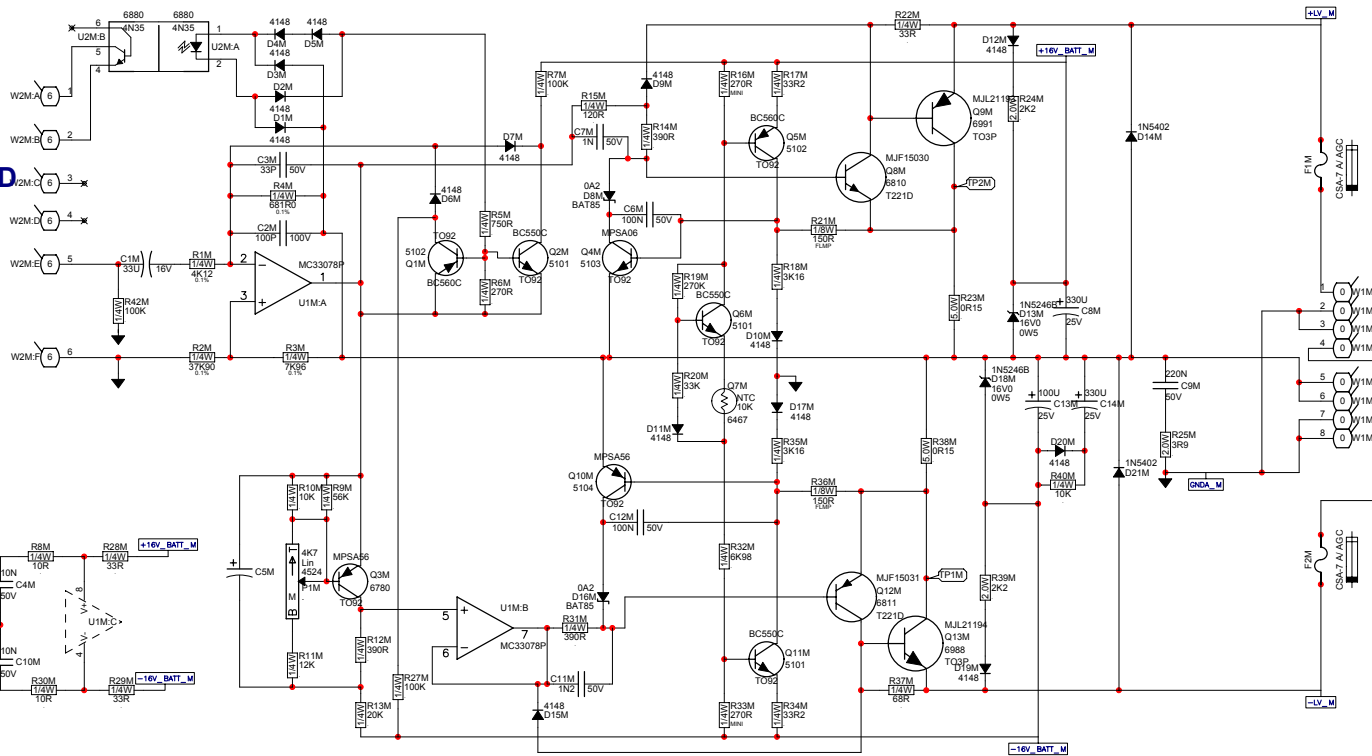

Adjust bias trim P1M to measure 4.5mV between TP1M and TP2M

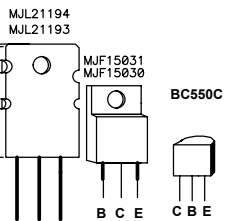

FROM INPUT BOARD

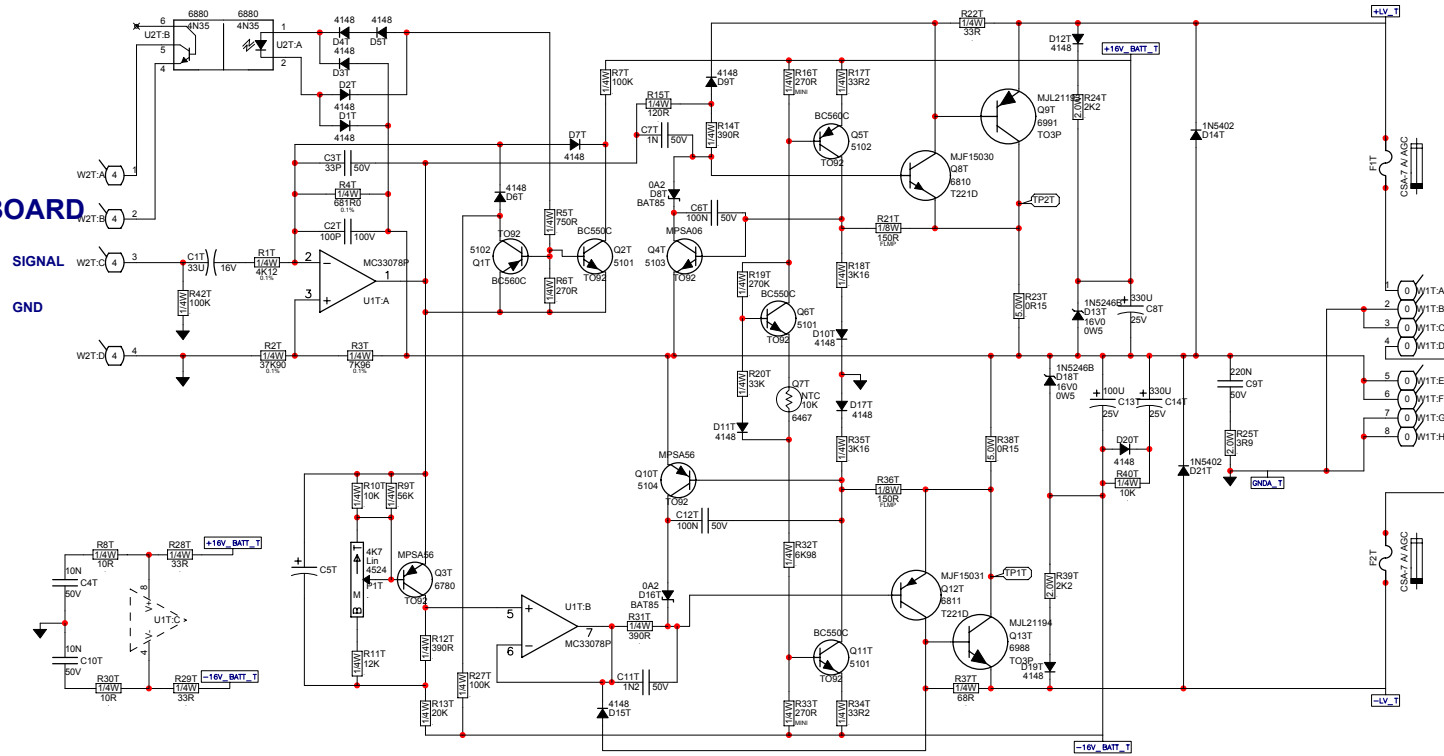

Adjust bias trim P1T to measure 4.5mV between TP1T and TP2T

M1233 Database History			
MODEL(S):- U15P			
#	DATE	VER#	DESCRIPTION OF CHANGE
1	4JUL2005	P3	Changed 6115 -> 4992
2	D	V	Removed routed finger holes
3	D	V	Changed Q10T,M from 6780 to 5104
4	2-NOV-2005	P3	Added R41T 41M,42T,42M
5	14FEB2006	V0	Removed R41M, T, shorted pin3 of U1M,T to GND
6	D	V	N
7	D	V	N
8	D	V	N
9	D	V	N
10	D	V	N
11	D	V	N
12	D	V	N
13	D	V	N



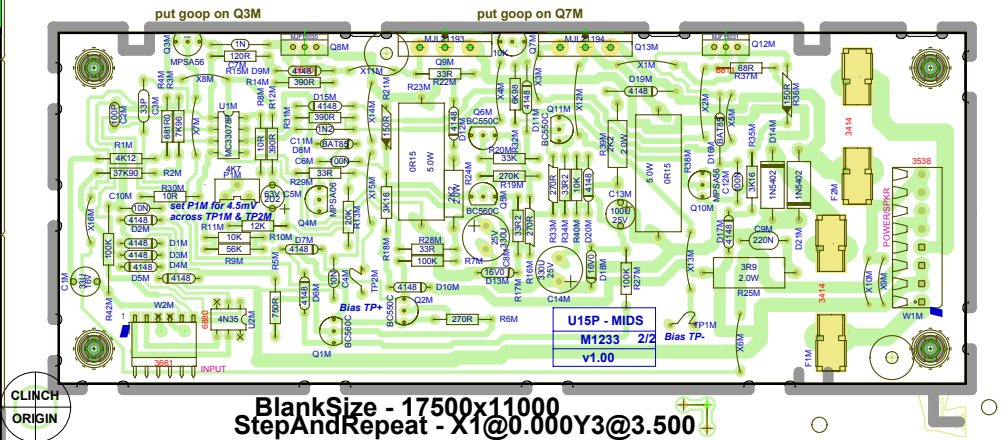
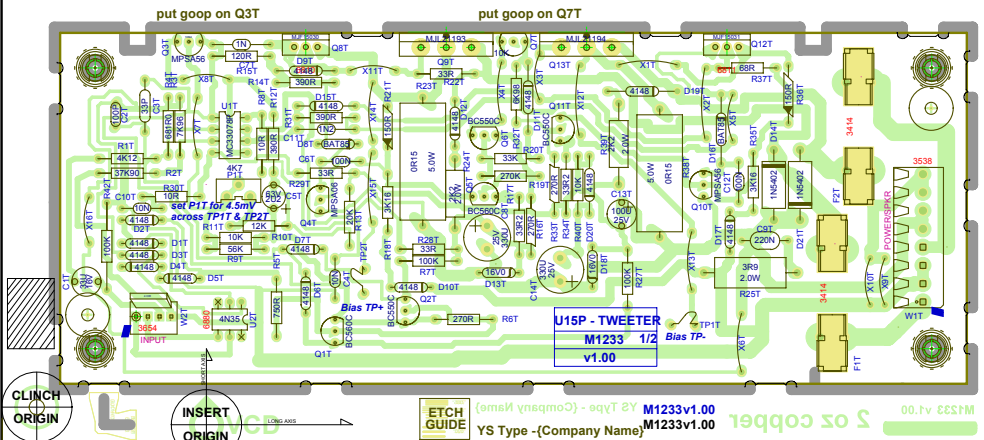

BlankSize - 17500x11000
 StepAndRepeat - X1@0.000Y3@3.500

M1233 REVISION HISTORY			
MODEL(S):-	U15P		
#	DATE	VER#	DESCRIPTION OF CHANGE
1	4JUL2005	P3	Changed 6115 -> 4992
2	D	V	Removed routed finger holes
3	D	V	Changed Q10T_M from 6780 to 5104
4	2-NOV-2005	P3	Added R41T, 41M, 42T, 42M
5	14FEB2006	1V0	Removed R41M, T, shorted pin3 of U1M, T to GND
6	D	V	N
7	D	V	N
8	D	V	N
9	D	V	N
10	D	V	N
11	D	V	N
12	D	V	N
13	D	V	N

M1233 DRILL HISTORY			
MODEL(S):-	U15P		
#	DATE	VER#	DESCRIPTION OF CHANGE
1	D	V	N
2	D	V	N
3	D	V	N
4	D	V	N
5	D	V	N
6	D	V	N

M1233 PENDING LIST			
MODEL(S):-	U15P		
#	DATE	VER#	DESCRIPTION OF CHANGE
1	D	V	N
2	D	V	N
3	D	V	N
4	D	V	N
5	D	V	N
6	D	V	N

FORCE UPDATED JUNE 21, 2005

PRODUCTION NOTES

- Q3T AND Q3M ARE HAND INSERTED
- Q3T, Q3M, Q7T, Q7M NEED TO BE GOOPED BEFORE BOARD IS BOLTED TO HEATSINK

ADD SPACERS TO TRANSISTORS

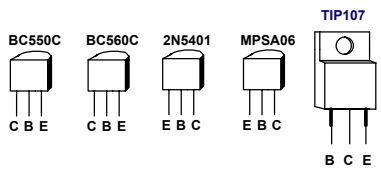
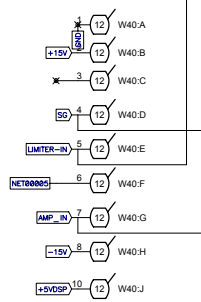
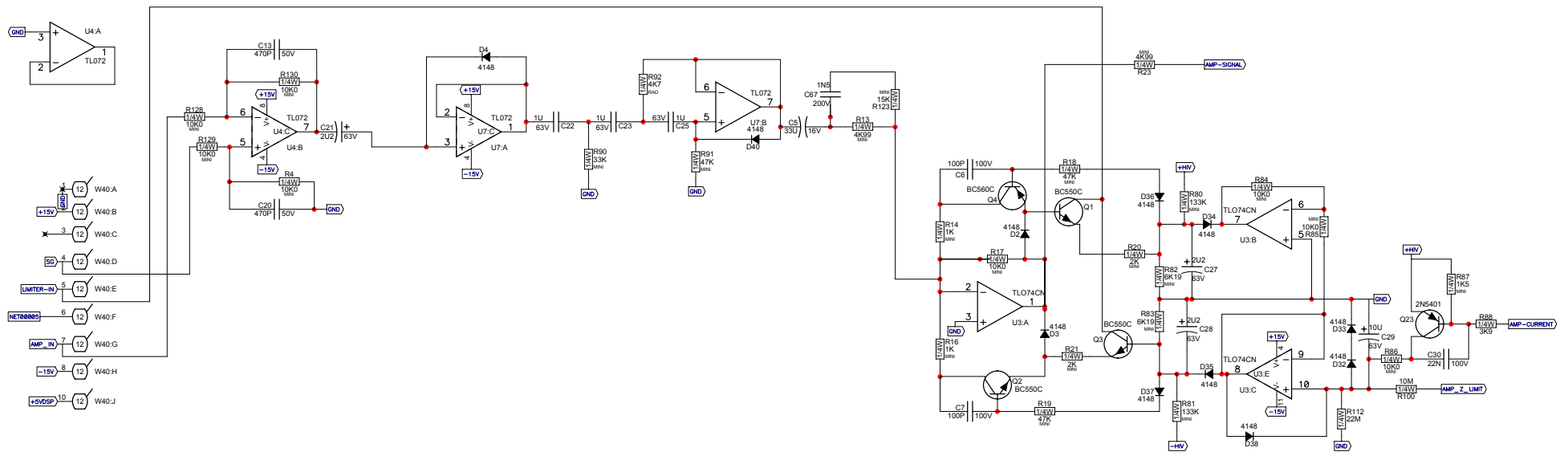

M1324 Database History			
MODEL(S):-	U15P		
#	DATE	VER#	DESCRIPTION OF CHANGE
1	13SEPT2005	P2	R3 2006 --> 4688
2		N	
3	14SEPT2005	P2	Added CONHOLE to chassis for GND
4	31OCT2005	P2	Modified XFMR colours
5	8NOV2005	P2	Q14,15,24,25 from 3205 (#6954) to 2910 (#6966)
6	9NOV2005	P2	Removed X33, changed X6,7
7	19DEC2005	P3	Increased size of relay board
8			
9	10JAN2006	P3	Added mounting holes & deleted W29, changed colour W55
10	26JAN2006	P3	Changed SPKR wire colours
11	14FEB2006	1V0	Re-routed PS GND, added ferrites to relay brd power, del LG
12	1D	V	Removed W12, input limiter circuitry, changed C38,39,31,5,8
13	9MAR2006	1V0	Changed horn output relays to DC powered, R65 to 20K
1	21MAR2006	1V0	PC#7126:GT:ADDED X33 TO JUMP GND TO W40 PIN1
2	MAY-16-2006	V2.00	MOVED W57, W58, W62 DOWN 150MIL FOR CHASSIS
3	D	N	
4	D	N	
5	D	N	
6	D	N	
7	D	N	
8	D	N	
9	D	N	
10	D	N	
11	D	N	
12	D	N	
13	D	N	

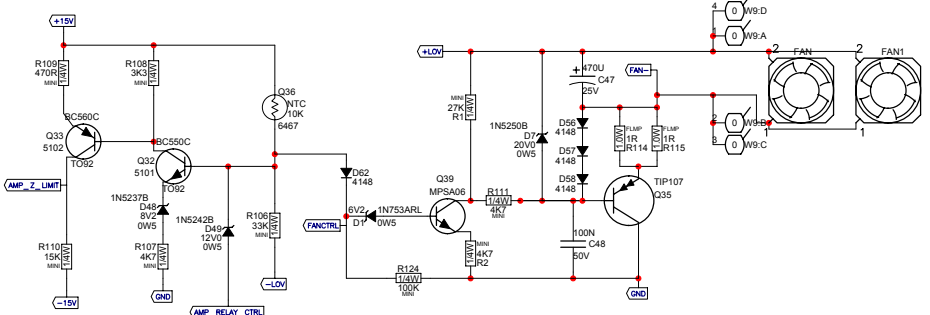

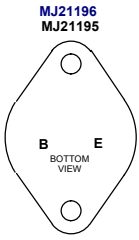
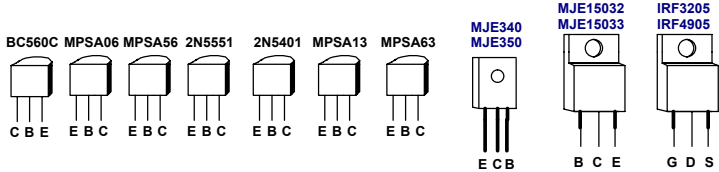
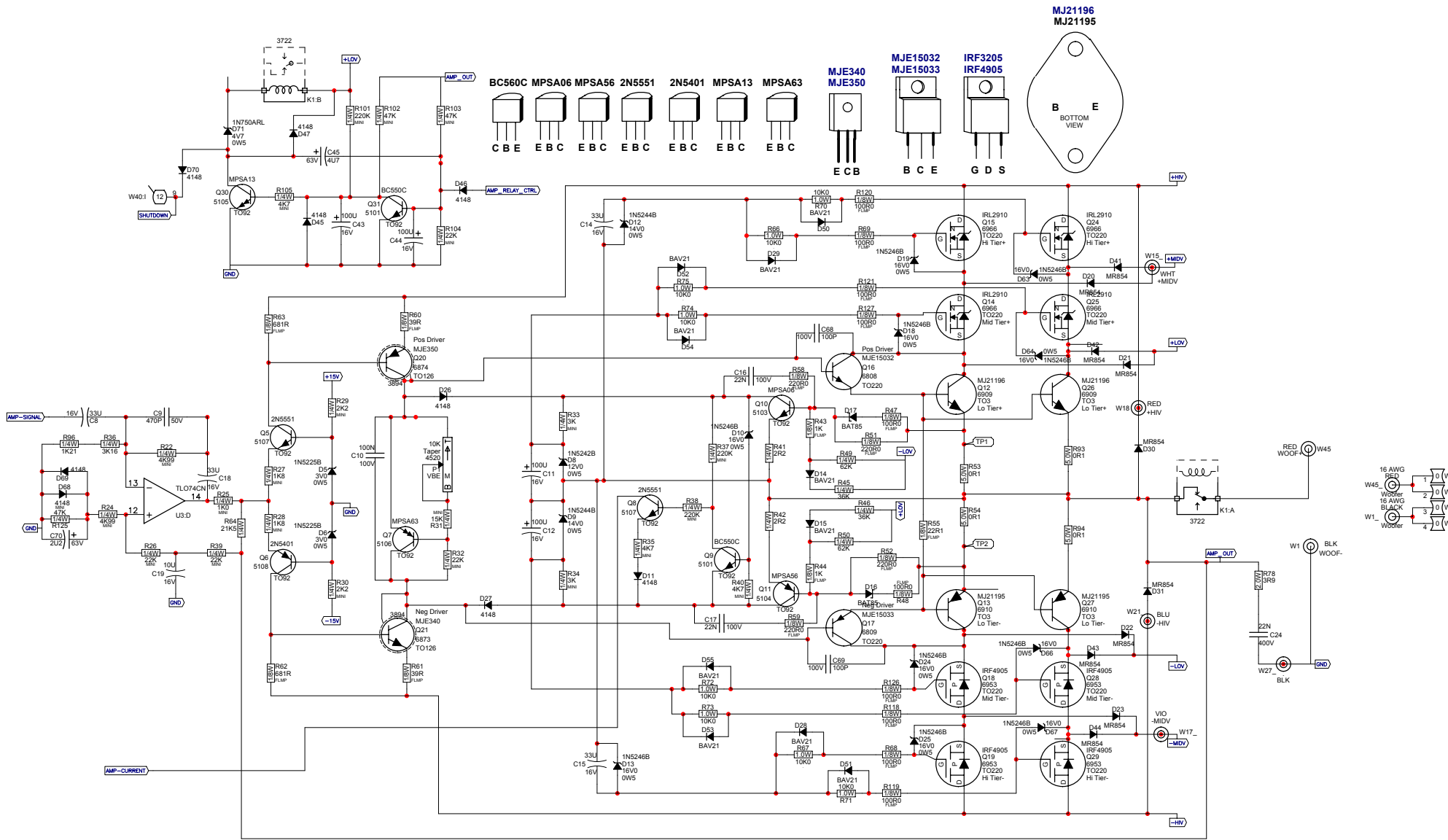

Adjust bias trim P1 to measure 8mV between TP1 and TP2



Product U15P		
AMP	PCB# M1234	Sheet 2 of 4
Date: Wed Jun 07, 2006	Rev: V2.00	
Filename: m1234-2v00p0.sch2002		

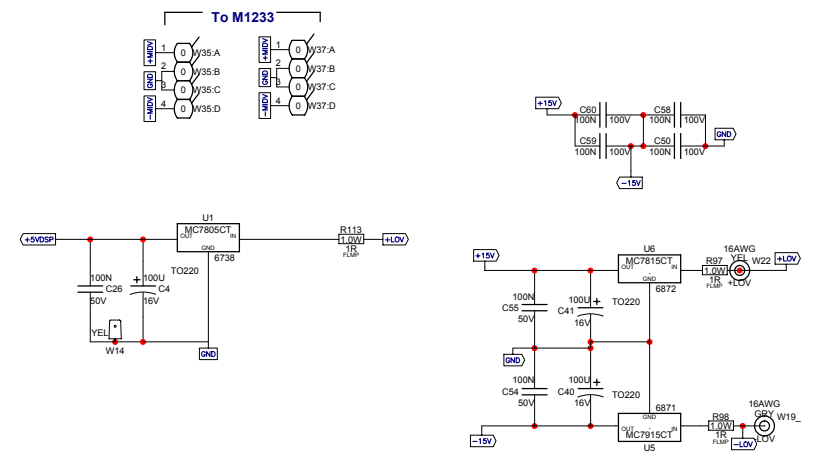
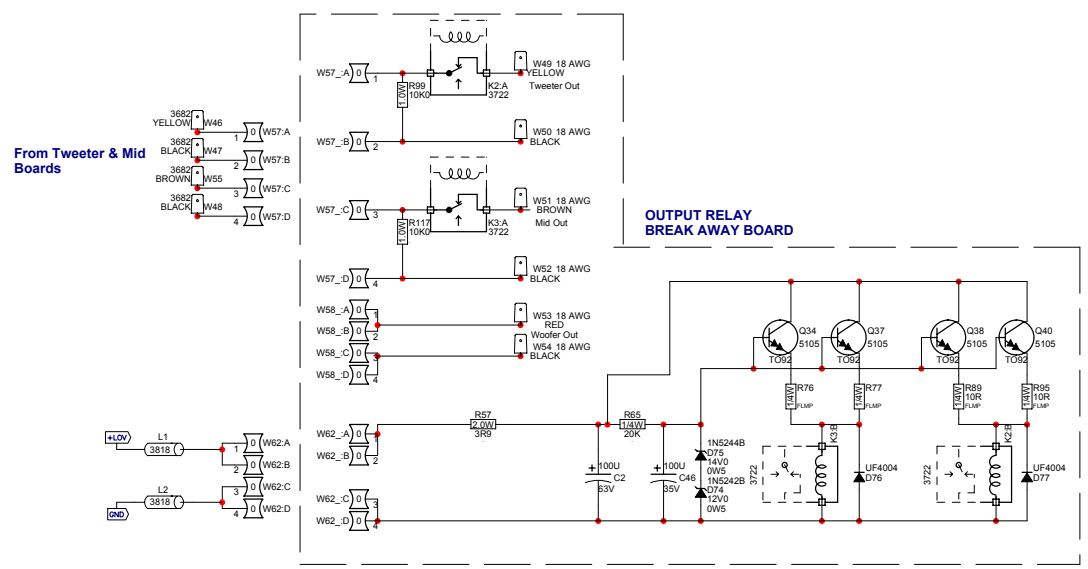
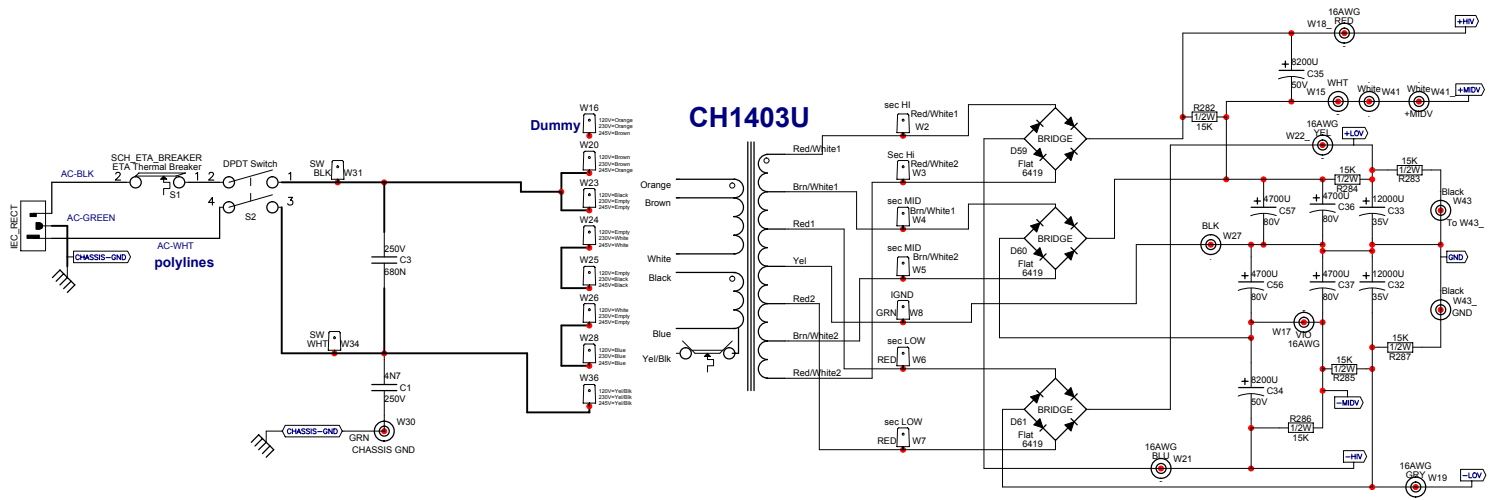

ETCH GUIDE

Top Assy
Pcb Mech

ETCH GUIDE

BlankSize - 18250x9500

M1234 V2.00

2 oz copper

DON'T PLACE COMPONENTS HERE
CHASSIS SCREWS BRACE TOP OF BOARD
HERE

WARNING!
FOR CE:
CHASSIS MUST
NOT COME CLOSER
THAN THIS LINE TO
THE BOARD
COPPER TRACES
OF SECTION 1/2

Place 4 of #8841 10-32 keps nuts before the heatsink.

HEAVY STUFF

SEE LAYOUT DOCUMENTATION

Two fans

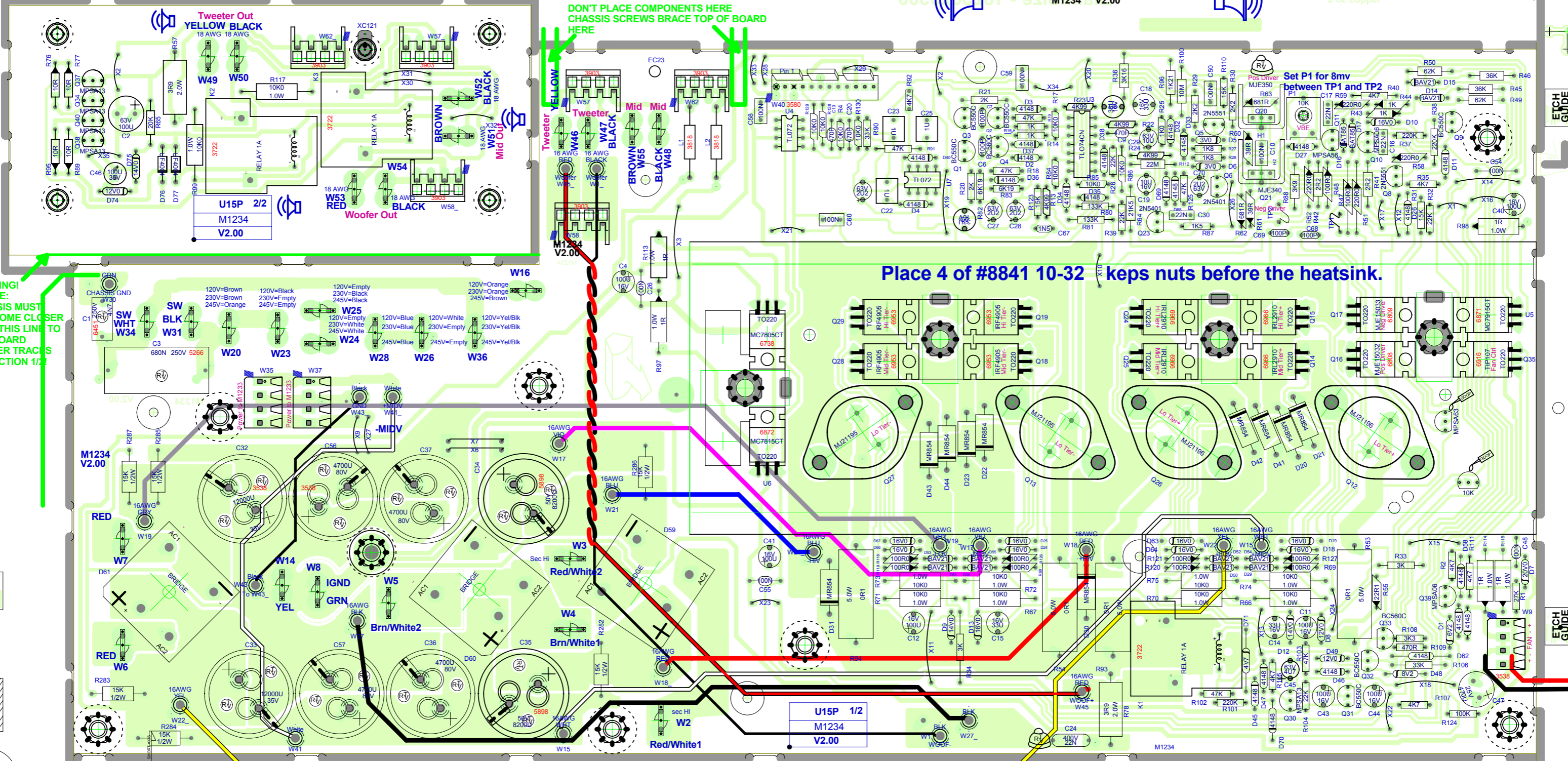
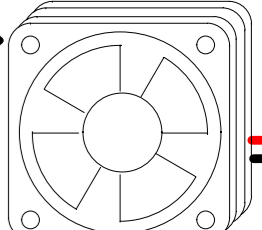

ETCH GUIDE

CLINCH ORIGIN

INSERT ORIGIN

ETCH GUIDE

ETCH GUIDE

ETCH GUIDE

ETCH GUIDE



SEE LAYOUT DIAGRAM



M1234 Pending List

MODEL(S):-		U15P	
#	DATE	VER#	DESCRIPTION OF CHANGE
1	D	V	N
2	D	V	N
3	D	V	N
4	D	V	N
5	D	V	N
6	D	V	N

M1234 Drill History

MODEL(S):-		U15P	
#	DATE	VER#	DESCRIPTION OF CHANGE
1	8NOV2005	P2	Moved to silkscreen holes and several mounting holes
2	D	V	N
3	D	V	N
4	D	V	N
5	D	V	N
6	D	V	N

LEAD/PIN REFERENCE

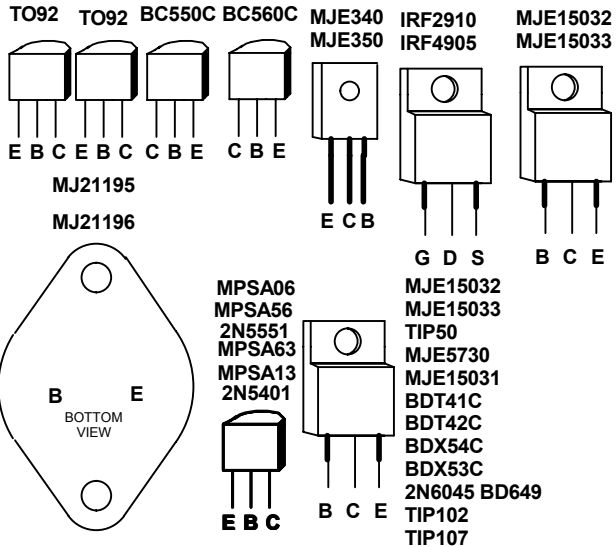

PRODUCTION NOTES

Board Assembly

1 - MOUNT Q12,Q13,Q26,Q27 SCREWS FROM THE TOP

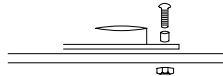

2 - BOARD ASSEMBLY: INSERT Q36 #6467 10K THERMISTOR BY HAND



3 - FILL SPACE BETWEEN HEATSPREADER AND Q7 AND Q36 WITH THERMAL GOOP

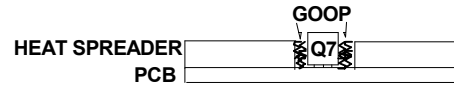

4 - INSERT #8829 THROUGH THE TWO TOOLING HOLES ON THE HEATSPREADER

5 - CONNECT BREAK-AWAY BOARD TO UNDERSIDE OF MAIN BOARD USING THREE #3668 CONNECTORS AFTER DROPPING BOARD INTO CHASSIS

6 - RTV LARGE ELECTROLYTIC CAPACITORS TOGETHER, RTV SMALL ELECTROLYTICS TO THE BOARD

7 - TAPE OFF GROUND RING NEAR SUPPLY CAPS BEFORE WAVE SOLDERING. THIS AREA MUST BE FLAT WHEN ASSEMBLING CHASSIS

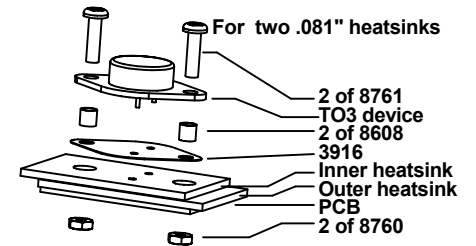
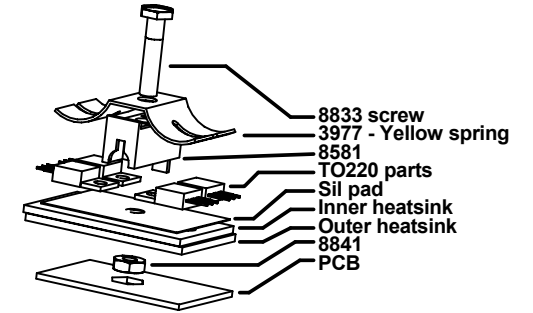

FROM TAS3103

TO TAS3103

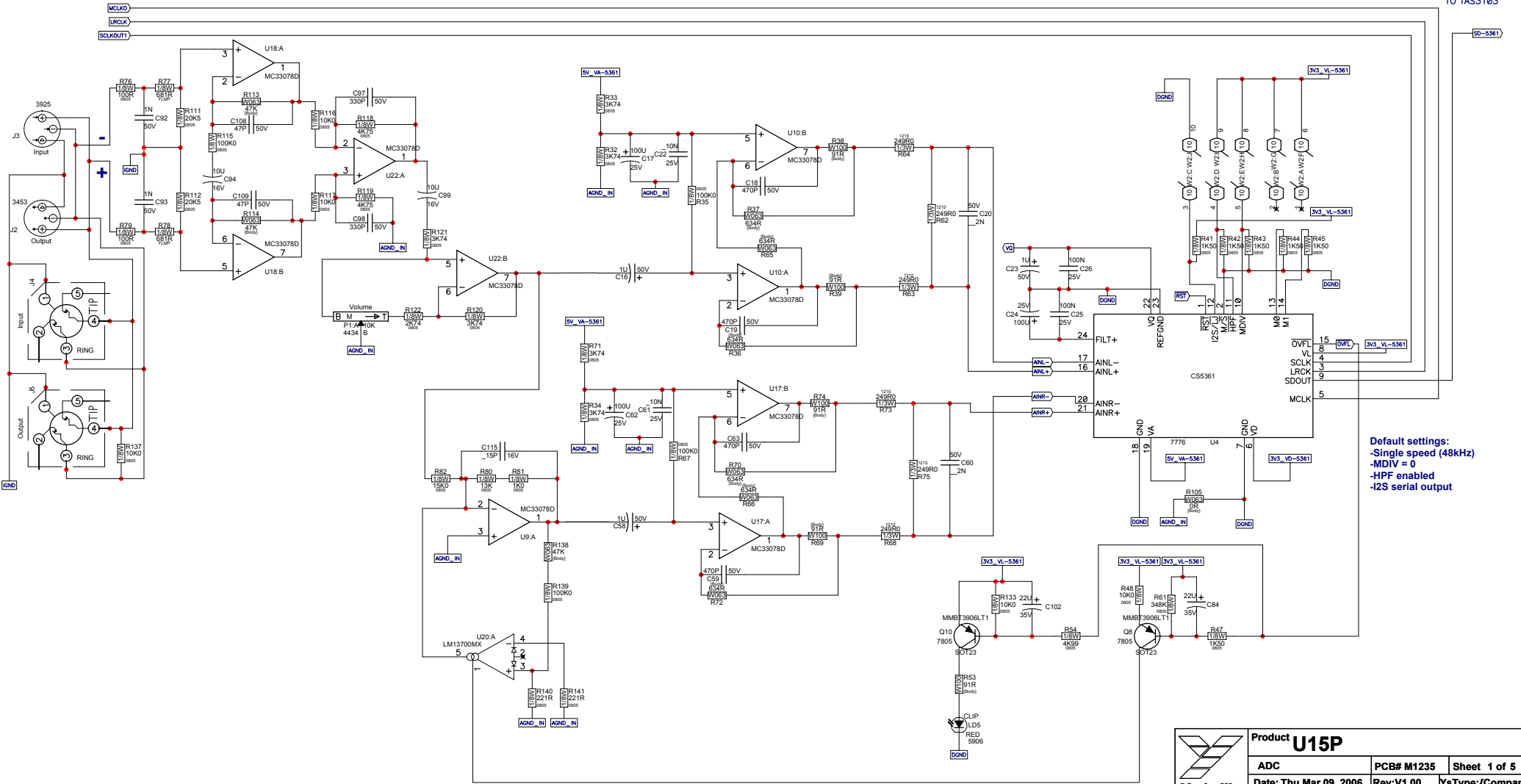

Default settings:
 -Single speed (48kHz)
 -MDIV = 0
 -HPF enabled
 -I2S serial output



Product U15P		
ADC	PCB# M1235	Sheet 1 of 5
Date: Thu Mar 09, 2006	Rev: V1.00	YsType: (Company)
Filename: m1235 v1.00sch.sch2002		

FROM ADC

SD-5361

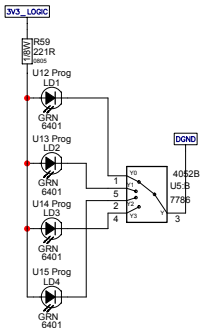

FROM PADDLE BOARD (DAREF106)

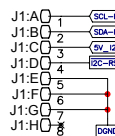

Default Settings:
 -Master Mode
 -PLL set for Fs=48kHz
 -MICROCLK = DAP/4

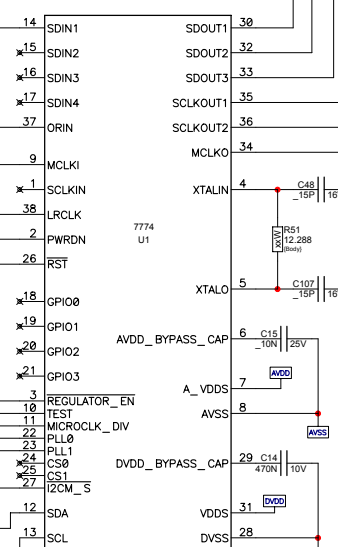

TO DAC
 LRCLK
 SDOUT1
 SDOUT2
 SDOUT3
 SCLKOUT2
 MCLK0
 TO ADC
 MCLK0
 LRCLK
 SCLKOUT1

TO POWER
 I2C-RST
 WR

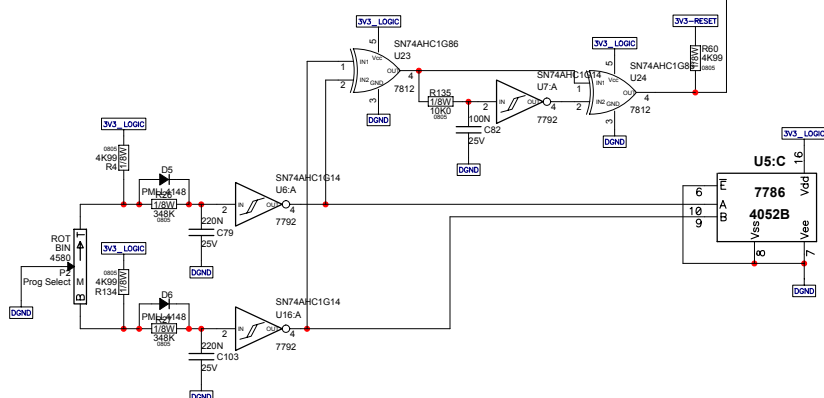

Product U15P		
DSP	PCB# M1235	Sheet 2 of 5
Date: Thu Mar 09, 2006	Rev: V1.00	YsType: (Company)
Filename: m1235 v1.00sch.sch2002		

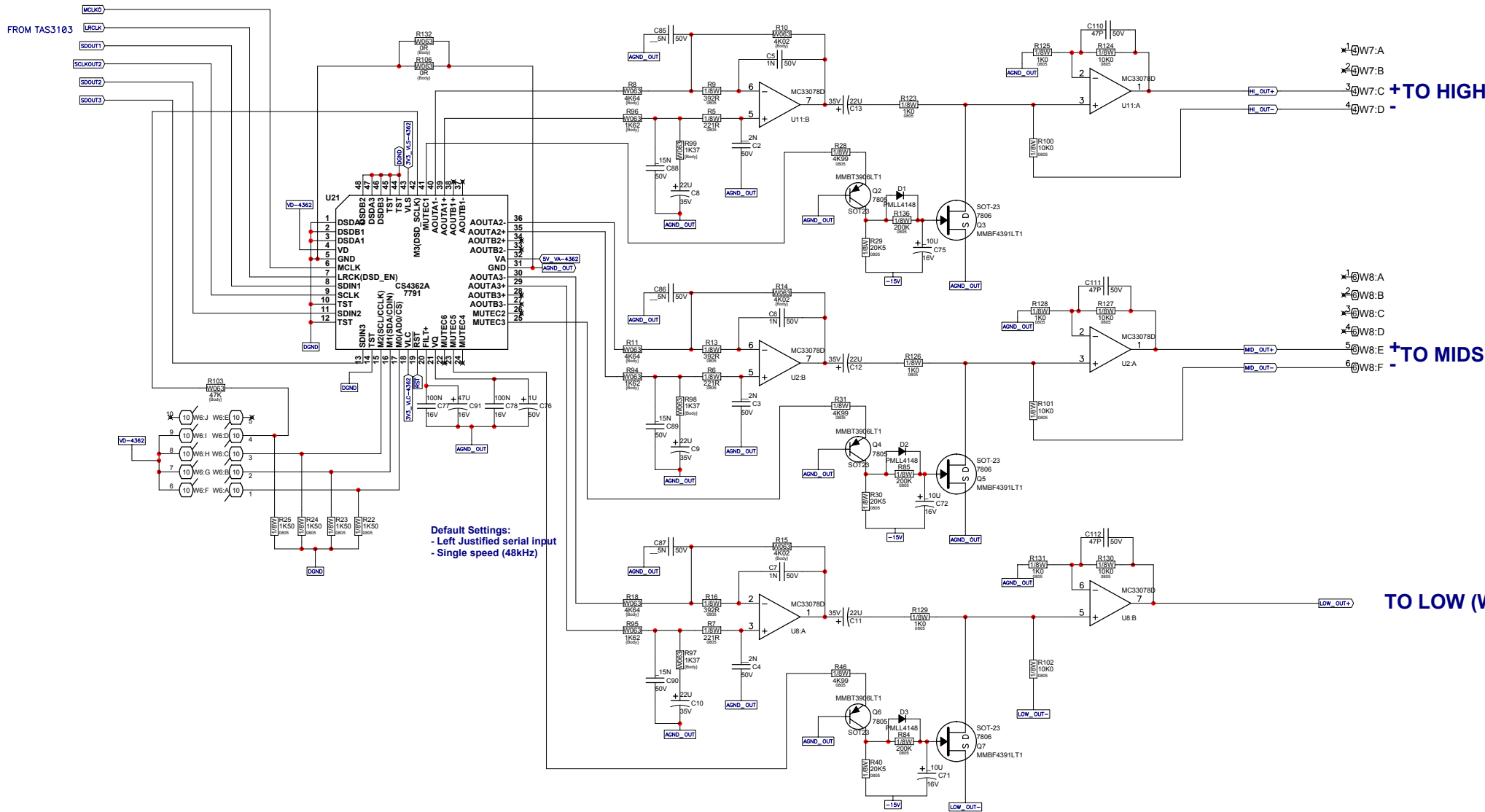

Default Settings:
 - Left Justified serial input
 - Single speed (48kHz)

1 @W7:A
 2 @W7:B
 3 @W7:C **+TO HIGH**
 4 @W7:D -

1 @W8:A
 2 @W8:B
 3 @W8:C
 4 @W8:D
 5 @W8:E **+TO MIDS**
 6 @W8:F -

TO LOW (W3)



Product U15P		
DAC	PCB# M1235	Sheet 3 of 5
Date: Thu Mar 09, 2006	Rev: V1.00	YsType: (Company)
Filename: m1235 v1.00sch.2002		

RIBBON TO AMP

- W3:A 1 [DGND]
- W3:B 2 [+15V]
- W3:C 3 [LIMITER-IN]
- W3:D 4 [LOW_OUT-]
- W3:E 5 [LIMITER-OUT]
- W3:F 6 [LOW_OUT+]
- W3:G 7 [-15V]
- W3:H 8 [5V_IN]
- W3:I 9 [5V_IN]
- W3:J 10 [5V_IN]
- W3:K 11 [5V_IN]
- W3:L 12 [5V_IN]

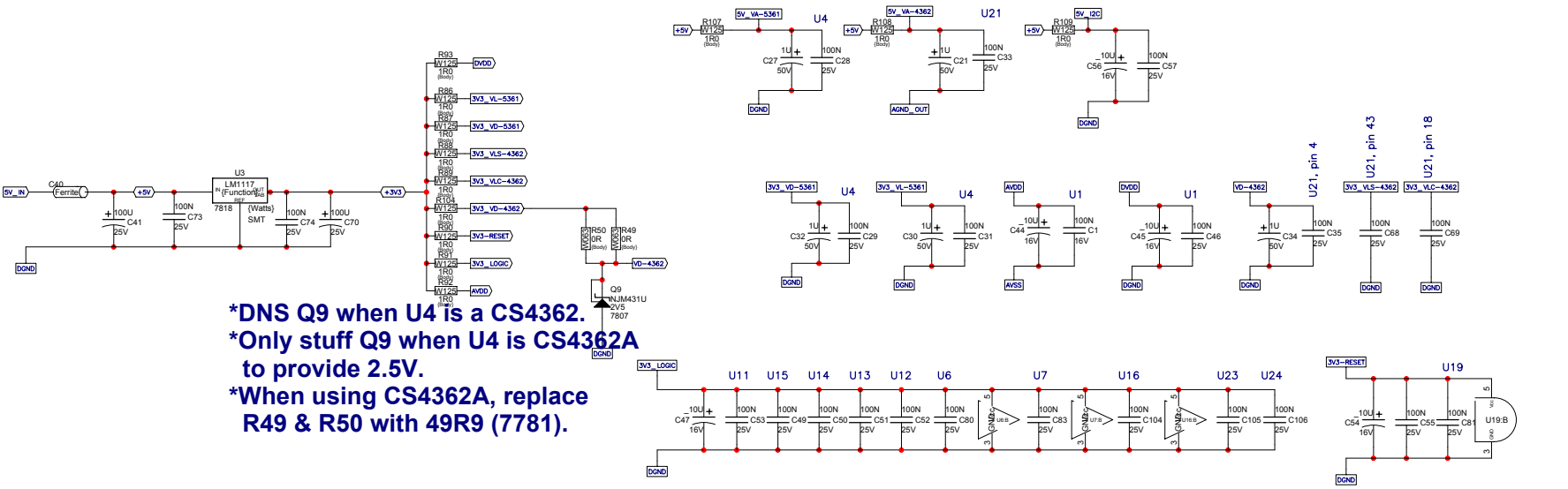
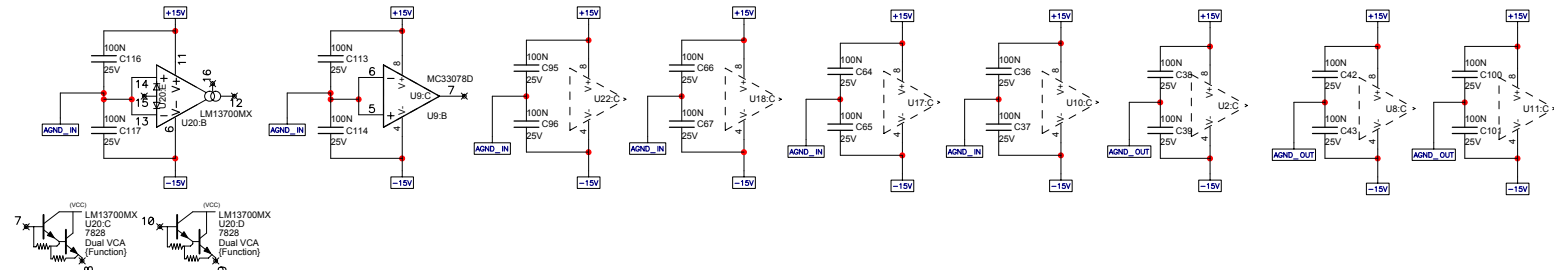

***DNS Q9 when U4 is a CS4362.**
***Only stuff Q9 when U4 is CS4362A to provide 2.5V.**
***When using CS4362A, replace R49 & R50 with 49R9 (7781).**

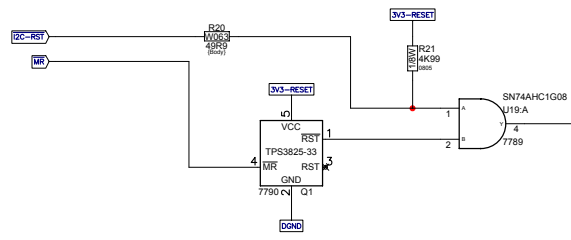

PRODUCTION NOTES

1. Do not stuff (DNS) Q9 when U4 CS4362. *Only stuff Q9 when U4 CS4362A to provide 2.5V.
2. DNS W1, W2, W6, and J1.
3. When using CS4362A, replace R49 & R50 with 49R9 (7781).

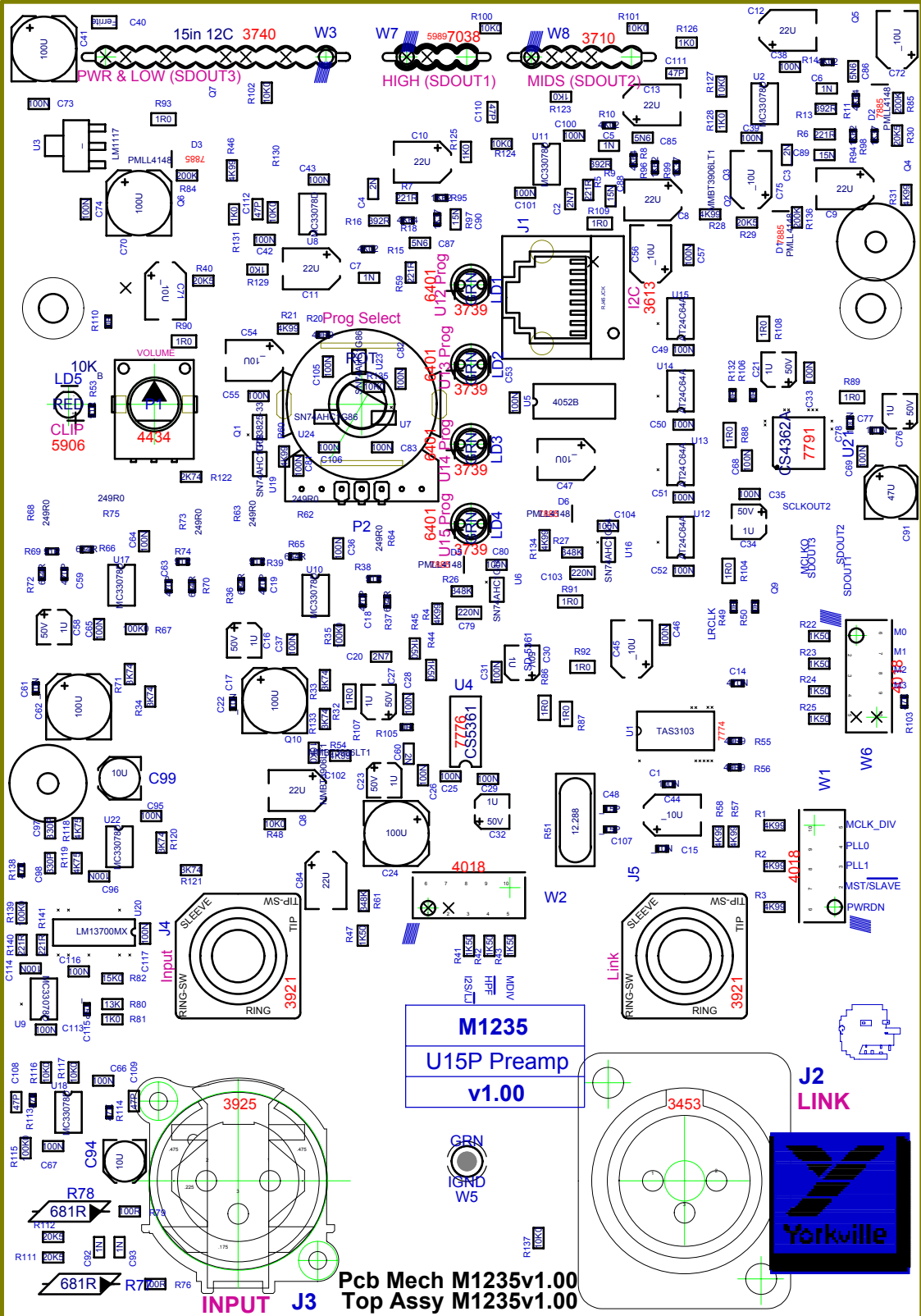

Pcb Mech M1235v1.00
Top Assy M1235v1.00

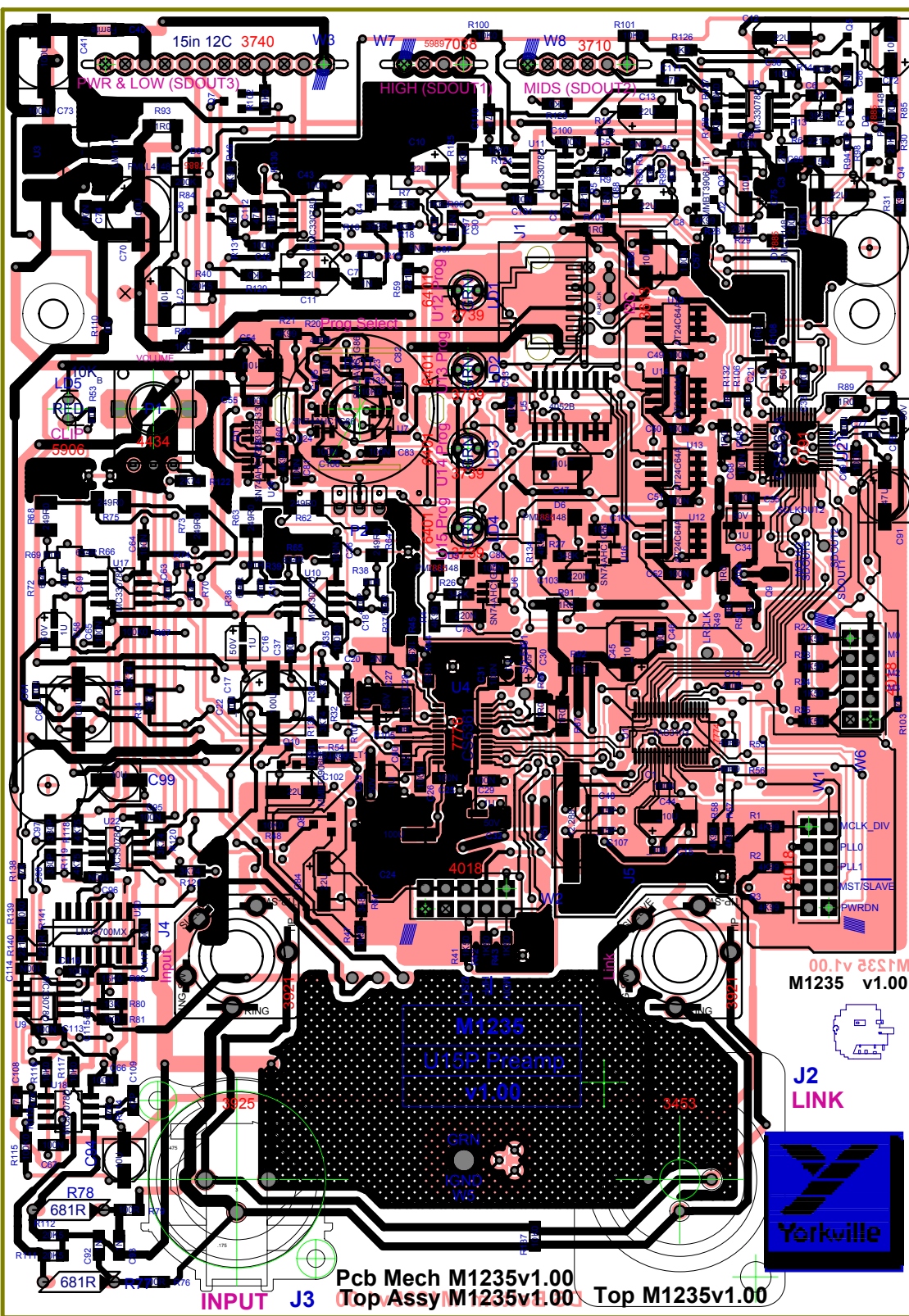

00.1v 23S1M
M1235 v1.00



J2
LINK



Pcb Mech M1235v1.00
Top Assy M1235v1.00 Top M1235v1.00

INPUT J3