

PRECAUTIONS CH- 2
CHARGING SYSTEM CIRCUIT CH- 3
IN-VEHICLE INSPECTION CH- 4
 BATTERY CH- 4
 ALTERNATOR CH- 4
ALTERNATOR CH- 8
 COMPONENTS CH- 8
 DISASSEMBLY CH- 9
 INSPECTION CH-10
 ASSEMBLY CH-15
SERVICE SPECIFICATIONS CH-18
SST CH-18
TIGHTENING TORQUE CH-18

JCH00001-00000

PRECAUTIONS

1. Prior to the inspection, be sure to turn OFF the ignition switch.
2. Never touch the terminals of the battery which is mounted on the vehicle immediately after the vehicle has been operated.
3. Since the battery electrolyte harms or damages the skin and clothes, pay utmost attention to handling of the battery.
4. The following shows how to apply first aid in the event that unexpected incidents happen in connection with the battery electrolyte.

JCH00002-00000

- (1) When you swallow the electrolyte:
Immediately rinse your mouth with clean water. Drink raw eggs, milk or a large quantity of water. Lie down and remain quiet. At the same time, call an ambulance or a doctor to receive medical treatments at a medical agency.
- (2) When the electrolyte gets into your eyes:
Flush the electrolyte gets away from your eyes with a large quantity of clean running water for at least 15 minutes. At the same time, call an ambulance or a doctor to receive medical treatments at a medical agency.
- (3) When the electrolyte splashes on your skin or clothes:
Flush the electrolyte away with a large quantity of clean running water, until there is no more electrolyte there. Then, neutralize the spot with soap water. After this treatment, call a doctor or consult with a doctor for advice.
- (4) When the electrolyte is spilled over the floor:
Flush the electrolyte away with a large quantity of clean running water, until there is no more electrolyte there. Then, neutralize the spot with hydrated lime.
- (5) When the electrolyte gets to a vehicle body:
Flush the electrolyte away from the affected section with a large quantity of clean running water, until there is no more electrolyte there.

JCH00003-00000

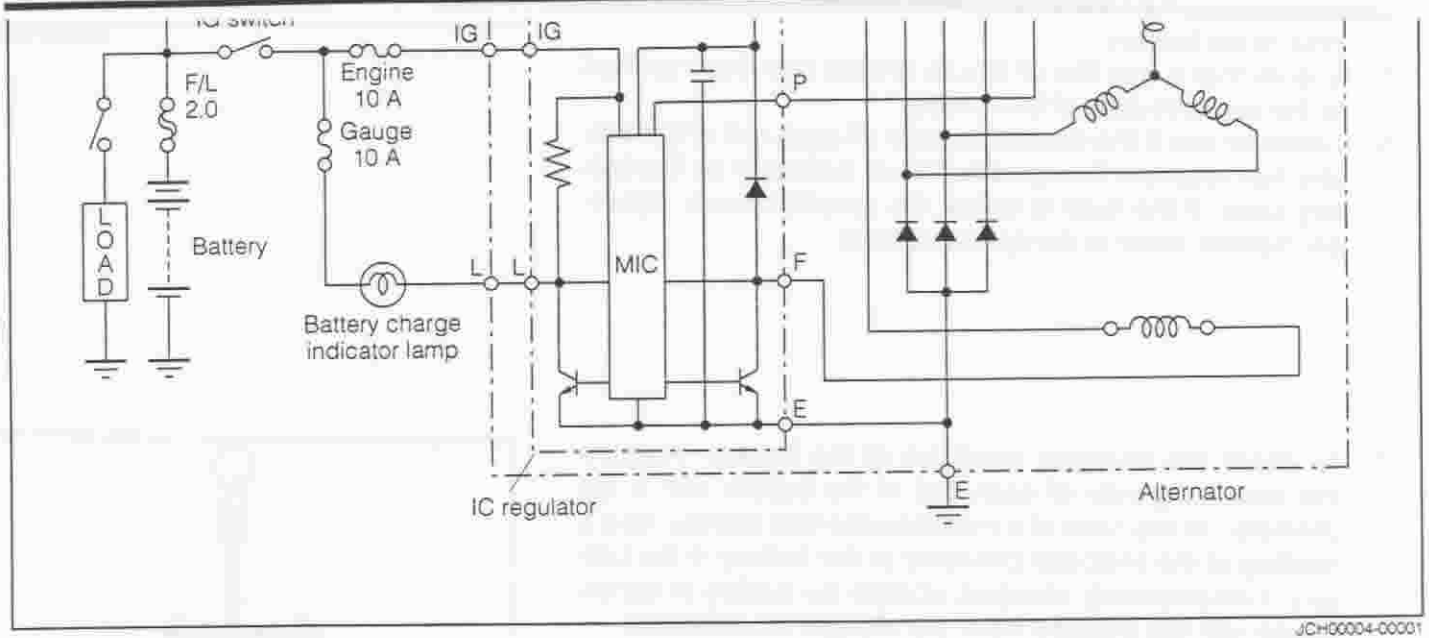

JCH60004-00001

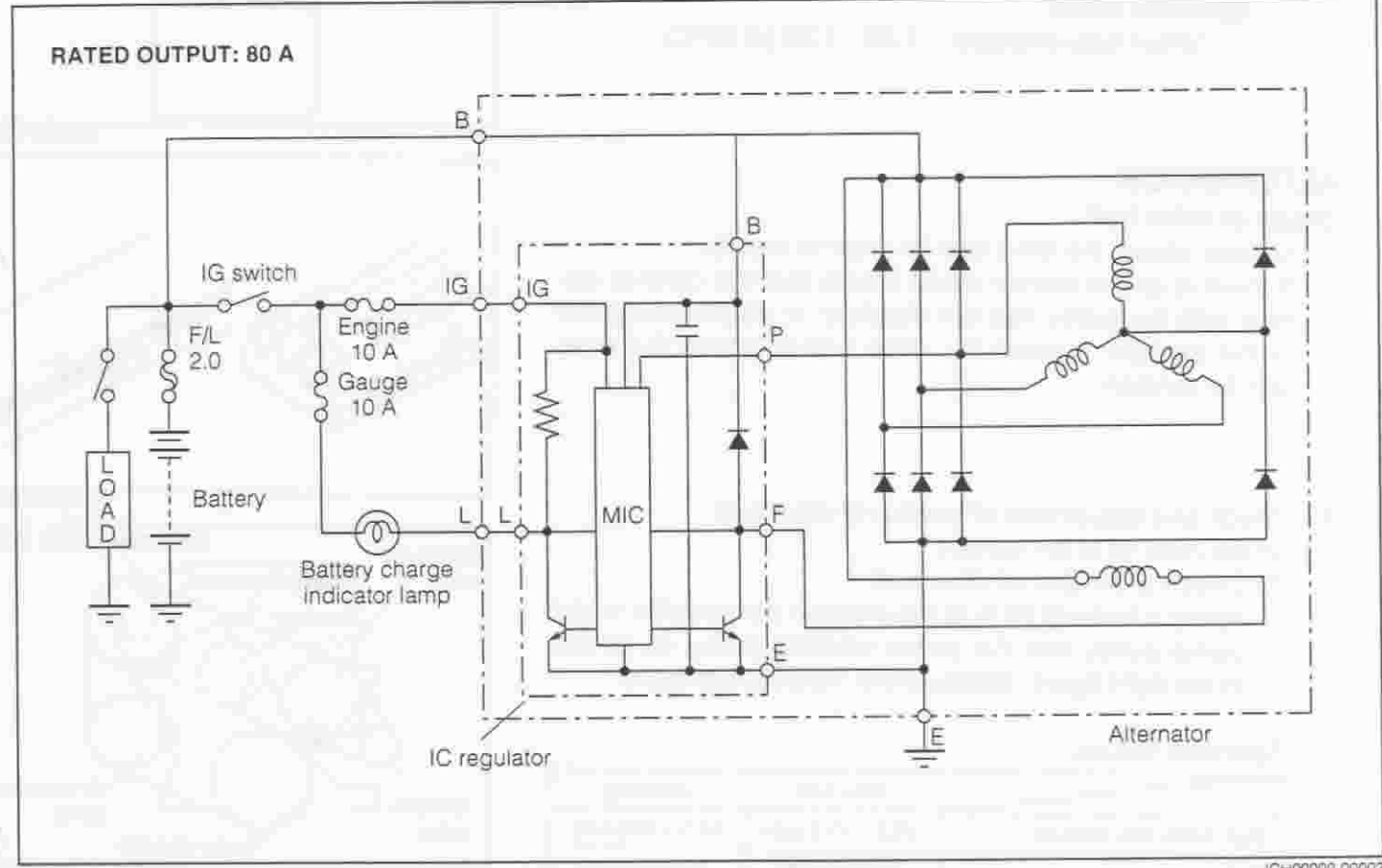

JCH00000-00002

IN-VEHICLE INSPECTION

BATTERY

1. If the battery case exhibits cracks, replace the battery with a satisfactory one.
2. If contamination, foreign matters or corrosion is found at the battery terminals, clean the battery.
3. Check that the battery terminals are connected with the cable securely without any looseness.
4. Ensure that the standard cover is mounted at the positive pole of the battery.
5. Ensure that a thin film of lithium grease has been applied to the negative pole of the battery.
6. Check to see if the electrolyte level of each cell of the battery has reached the specified level indicated on the battery case. If the level is below the specified level, replenish distilled water to the specified level.

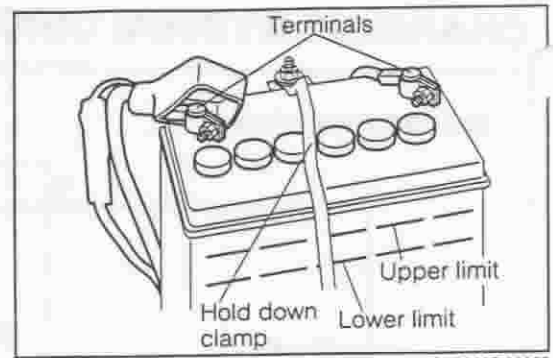

JCH00005-00003

7. To check the charging condition of the battery, measure the specific gravity of each cell of the battery with a hydrometer. In the case of a maintenance-free battery, take a reading of the indicator provided at the battery. If the battery is inadequately charged, charge the battery in accordance with the instructions of the charger manufacturer.

Specified Value:

When fully-charged: 1.25 - 1.28 (at 20°C)

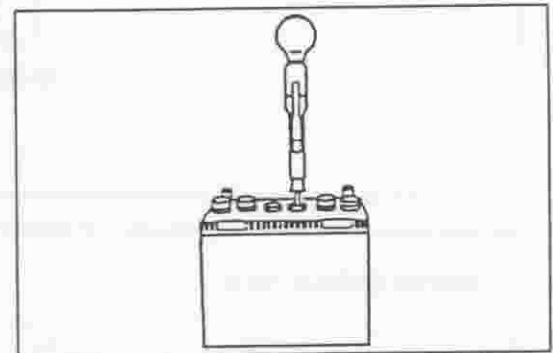

JCH00006-00004

ALTERNATOR

Check of drive belt

1. Visually check the drive belt for wear or cracks.
2. If there is any evidence which shows that the contact surface with the pulley has lost elasticity or slipping occurred in the surface, replace the drive belt or check the drive belt for tension.

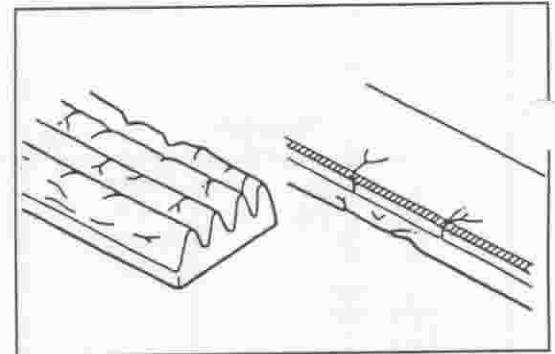

JCH00007-00005

3. Check and adjustment of tension of drive belt (In the case of M101 series)

(1) Check of tension of drive belt

Apply a force of 98 N to the position between the water pump pulley and the power steering pulley, as shown in the right figure. Measure the deflection amount.

Specified Values

	New belt	Used belt
Belt deflection amount	10.5 - 12.5 mm	14.5 - 16.5 mm
Belt tension	490 - 690 N	340 - 440 N

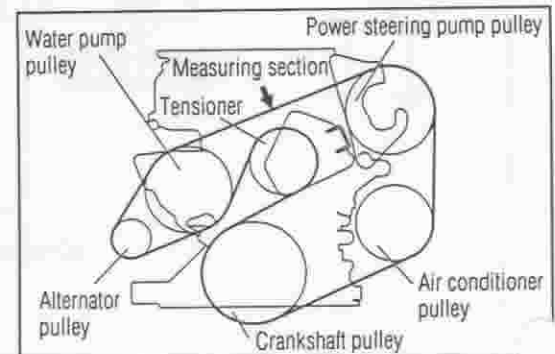

JCH00008-00000

NOTE:

- The tension can be measured by using a belt tension gauge.
- When installing a new belt, set the values to the median values of the specified values for new belts.
- When installing the belt that has been used on a running engine for more than five minutes, it should be adjusted to the median values of the specified values for used belts.

JCH0009-00007

(2) Adjustment of tension of drive belt

- ① Loosen the nut (B). Then, loosen the bolt (A). Under this condition, no belt tension is applied to the tensioner.
- ② Tighten the nut (B) by hand to such an extent that the tensioner may be retained without any excessive looseness.
- ③ Tighten the bolt (A) so that the belt tension may reach the specified value. Proceed to tighten the nut (B) fully to tighten the tensioner securely.
Tightening Torque: 35.2 - 52.8 N·m

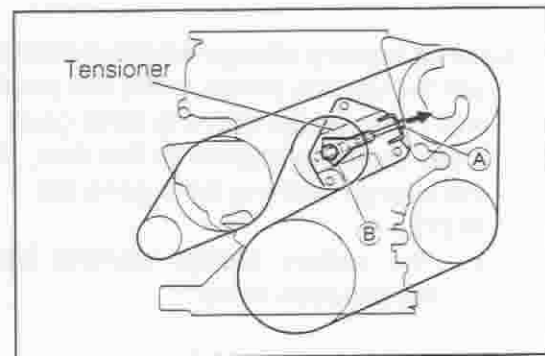

JCH0010-00008

NOTE:

- As for the bolt (A), be very careful not to over-tighten it beyond of a tension of 8 N·m.
- ④ Loosen the bolt (A) to a tightening torque of 3.9 to 4.1 N·m. (For this operation, loosen the bolt (A) about 1/2 turn.)
- ⑤ Check the tension of the drive belt.

(In the case of J102 series)

(1) Check of tension of drive belt

Apply a force of 98 N to the position between the water pump pulley and the tensioner, as shown in the right figure. Measure the deflection amount.

Specified Values

	New belt	Used belt
Belt deflection amount	9.0 - 11.0 mm	13.0 - 15.0 mm
Belt tension	490 - 690 N	340 - 440 N

NOTE:

- The tension can be measured by using a belt tension gauge.
- When installing a new belt, set the values to the median values of the specified values for new belts.
- When installing the belt that has been used on a running engine for more than five minutes, it should be adjusted to the median values of the specified values for used belts.

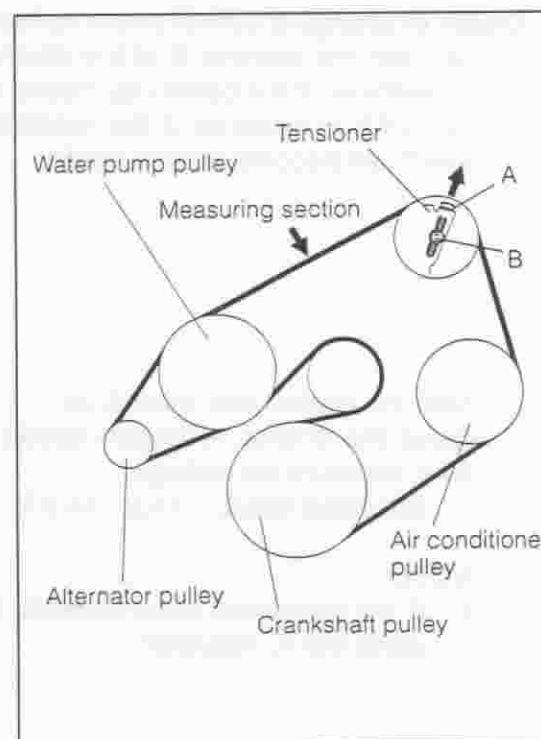

JCH0011-00009

(2) Adjustment of tension of drive belt

- ① Loosen the nut (B).
 - ② Adjust the tension by turning the bolt (A) and moving the idler pulley.
 - ③ Tighten the nut (B).
- Tightening Torque: 35.2 - 52.8 N·m
- ④ Check the tension of the drive belt.

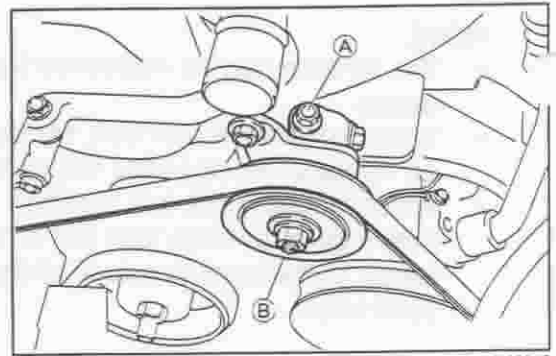

JCH00012-00010

Check of battery charge warning circuit

Set the ignition switch to the ON position. Visually check to see if the charge warning lamp goes on. Then, start the engine. At this time, visually check to see if the charge warning lamp goes out.

NOTE:

- The battery charge warning light is provided in the combination meter.

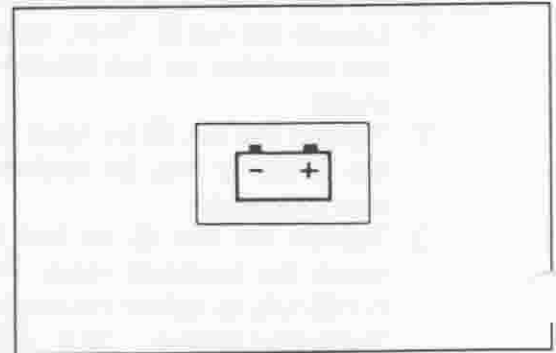

JCH00013-00011

Check of alternator

Ensure that the connector section of the wiring of the alternator is securely connected. Check to see if abnormal noise is emitted from the alternator while the engine is operating.

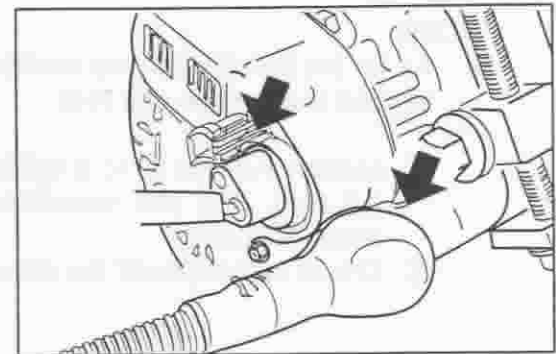

JCH00014-00012

Check of charging circuit under unloaded state

Connect the terminal B of the alternator with the negative (-) terminal of the battery by means of a voltmeter. Turn OFF all switches of the headlamps and other devices which will become electric loads.

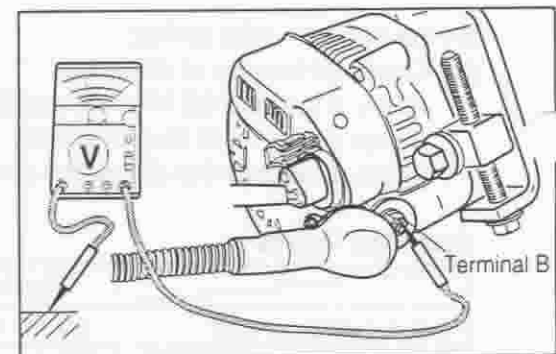

JCH00015-00013

Start the engine and warm it up. Raise the engine revolution speed to 2500 rpm. At this time, measure the voltage.

Specified Value: 14.2 - 14.8 V

NOTE:

- If the measured value exceeds the specified value, replace the IC regulator.

JCH00016-00000

If the measured voltage is less than the specified value, ground the terminal F of the alternator to the alternator proper, as shown in the right figure. Raise the engine revolution speed to 2500 rpm. At this time, measure the voltage.

NOTE:

- If the measured value exceeds the specified value, replace the IC regulator.
- If the measured value is less than the specified value, disassemble the alternator.

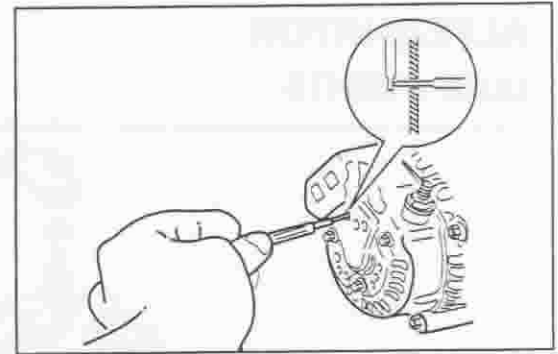

JC-H00017-00014

Check of charging circuit under loaded state

1. Disconnect the cable from the terminal B of the alternator and the battery.
2. Connect the terminal B of the alternator with the positive terminal (+) of the battery by means of an ammeter.
3. Turn ON the headlamp switch with the high beam position selected.
4. Turn ON the switch of the heater blower with the Hi position selected.

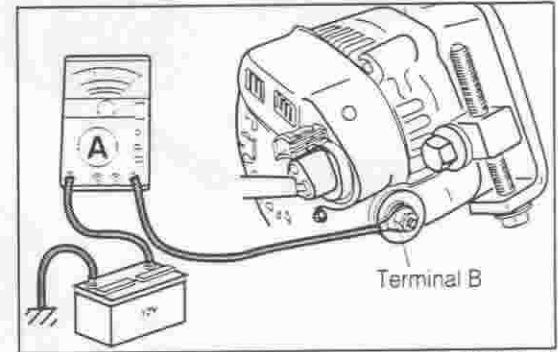

JC-H00018-00015

5. Start the engine and warm it up.
6. Raise the engine revolution speed to 2500 rpm. At this time, measure the current.

Specified Value: More than 30 A

NOTE:

- If the measured value less than the specified value, replace the alternator. However, there may be cases where the reading of the ammeter will not reach 30 A when the battery is fully charged.

JC-H00019-00000

ALTERNATOR COMPONENTS

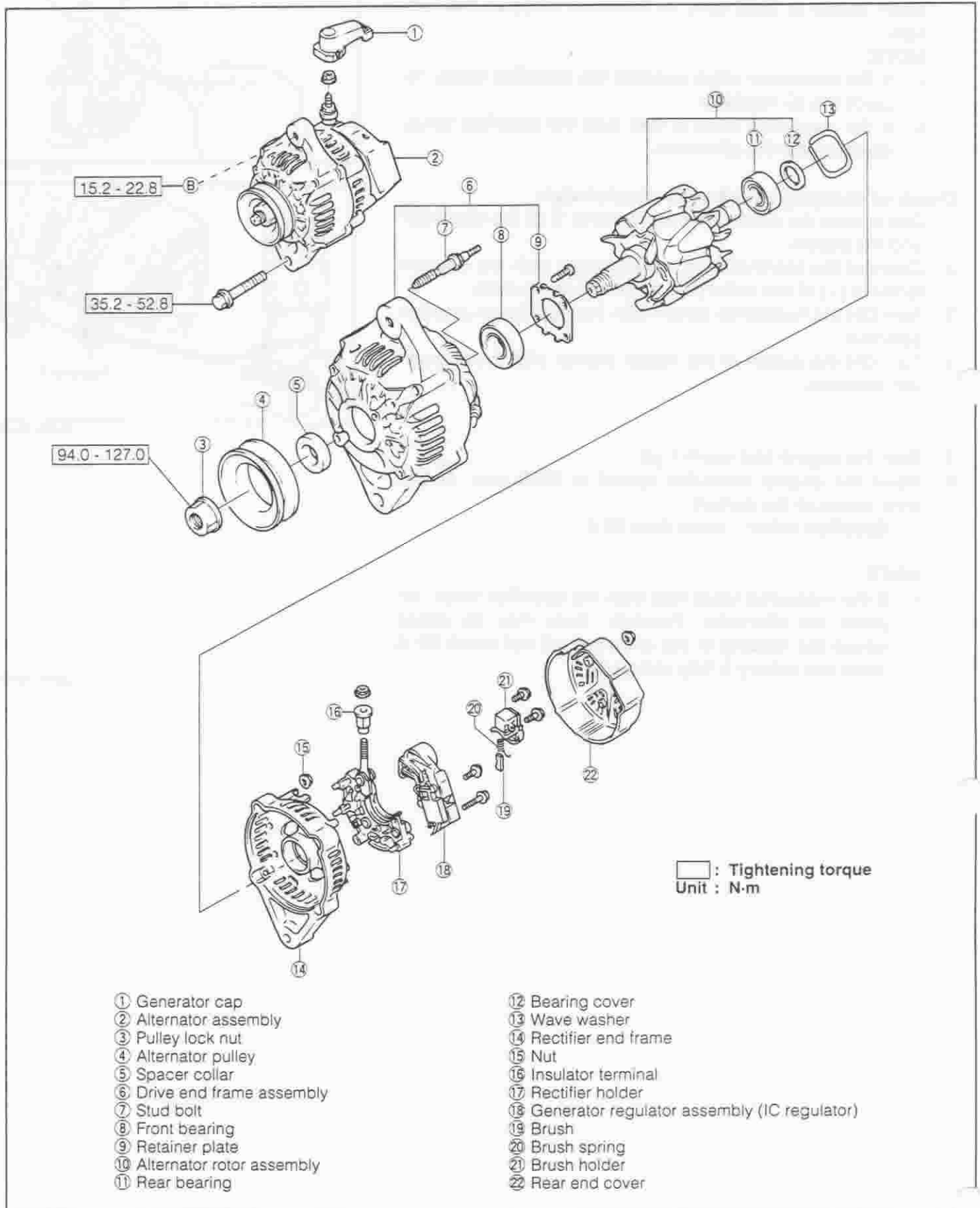

- ① Generator cap
- ② Alternator assembly
- ③ Pulley lock nut
- ④ Alternator pulley
- ⑤ Spacer collar
- ⑥ Drive end frame assembly
- ⑦ Stud bolt
- ⑧ Front bearing
- ⑨ Retainer plate
- ⑩ Alternator rotor assembly
- ⑪ Rear bearing

- ⑫ Bearing cover
- ⑬ Wave washer
- ⑭ Rectifier end frame
- ⑮ Nut
- ⑯ Insulator terminal
- ⑰ Rectifier holder
- ⑱ Generator regulator assembly (IC regulator)
- ⑲ Brush
- ⑳ Brush spring
- ㉑ Brush holder
- ㉒ Rear end cover

DISASSEMBLY

1. Remove the alternator pulley lock nut by means of an impact wrench, while holding the shaft by using a hexagonal box wrench.

NOTE:

- Be sure to use an impact wrench having a hexagonal hole.

2. Remove the alternator pulley and spacer collar.

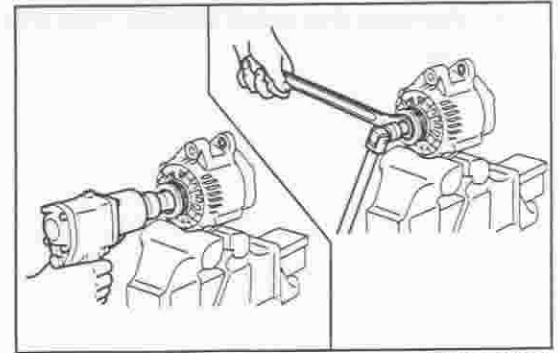

JCH00026-00021

3. Remove the attaching nut of the insulator terminal.
4. Pull out the insulator terminal.
5. Remove the three rear end cover attaching nuts.
6. Remove the rear end cover.

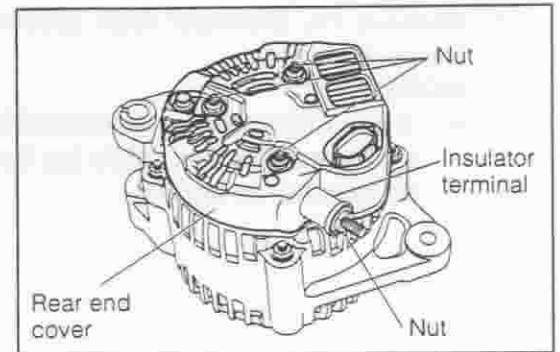

JCH00027-00022

7. Remove the brush holder by removing the two attaching screws.

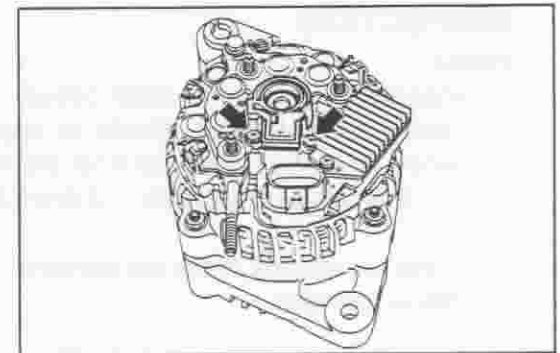

JCH00028-00023

8. Remove the IC regulator by removing the three attaching screws.
9. Remove the rectifier holder by removing the four attaching screws and one attaching bolt.

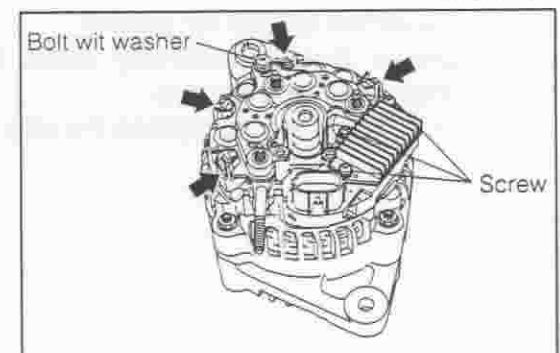

JCH00029-00024

10. Remove the rectifier end frame by removing the four attaching nuts.

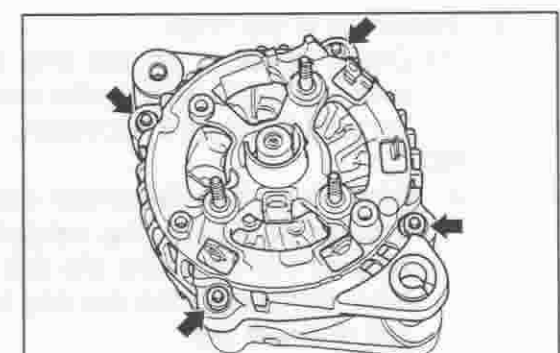

JCH00030-00025

11. Remove the wave washer from the alternator rotor assembly.

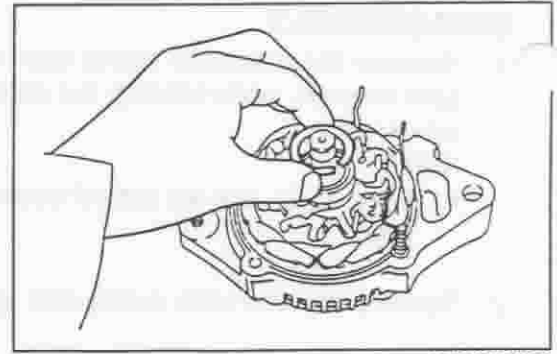

JCH00031-00026

12. Remove the alternator rotor assembly from the drive end frame assembly.

NOTE:

- If any difficulty is encountered in removing the alternator rotor assembly, lightly tap the rotor shaft with a plastic hammer or the like.

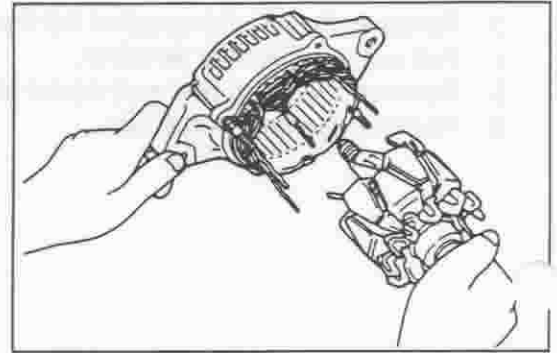

JCH00032-00027

INSPECTION

Rotor

1. Inspection of rotor for open circuit
Using an ohmmeter, check to see if the specified resistance exists between the rotor slip rings.

Standard Resistance: $2.9 \pm 0.2 \Omega$

If the resistance does not conform to the specification, replace the rotor.

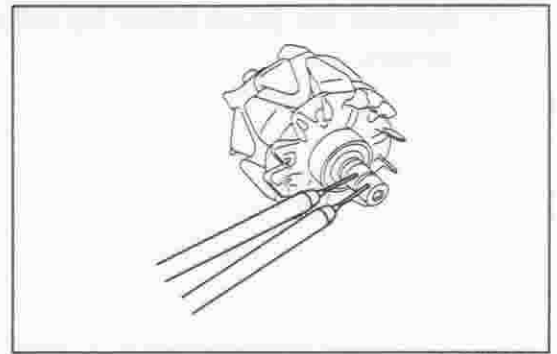

JCH00033-00028

2. Inspection of rotor for ground
Ensure that no continuity exists between the rotor slip rings and the rotor core.
If continuity exists, replace the rotor.

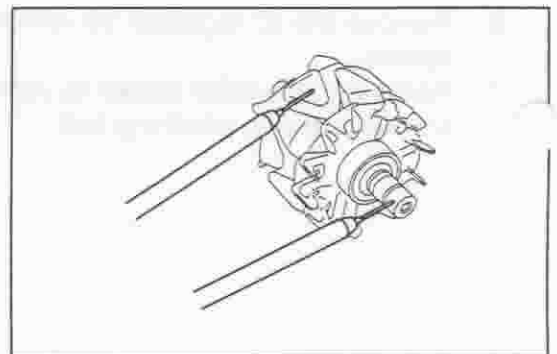

JCH00034-00029

3. Inspection of slip rings
(1) Check to see if the slip ring surface exhibits roughness, abnormal wear and/or burning.
Replace the rotor, if necessary.

NOTE:

- When correcting the smear and roughness of the slip ring, polish the slip ring, using fine sand paper (#300 - 500). In this case, the slip ring can be used, until the outer diameter of the slip ring is reduced 0.4 mm from that of a new one.

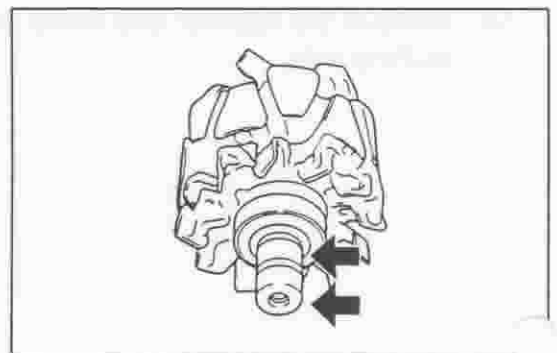

JCH00035-00030

(2) Measure the outer diameter of the slip ring, using vernier calipers.

Standard Diameter: 14.4 mm

Minimum Diameter: 14.0 mm

If the slip ring diameter is less than the minimum diameter, replace the rotor assembly.

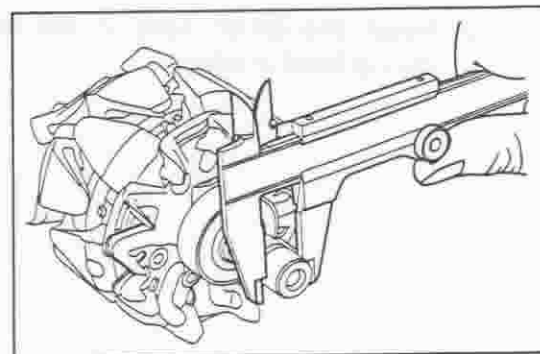

JCH00036-00031

Stator

1. Inspection of stator for open circuit
Using an ohmmeter, check to see if any open circuit of the stator coil is present between the leads.

If no continuity exists, replace the end frame assembly.

Specified Resistance: About 0.2 Ω

NOTE:

- If no continuity exists, there is no possibility that the stator coil itself exhibits open wire. Therefore, check the connecting section of the lead wire.

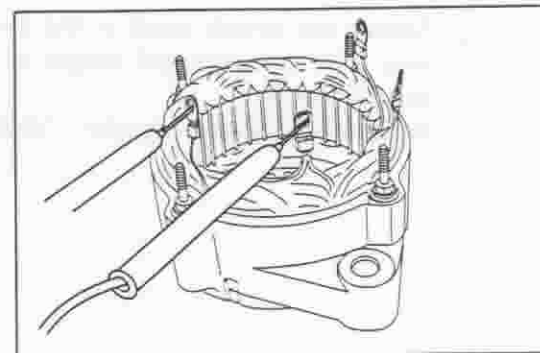

JCH00037-00032

2. Inspection of stator for short circuit
Using an ohmmeter, check to see if any short circuit of the stator coil is present between the coil lead and the drive end frame.

If continuity exists, replace the drive end frame assembly.

Specified Resistance: More than 1 k Ω

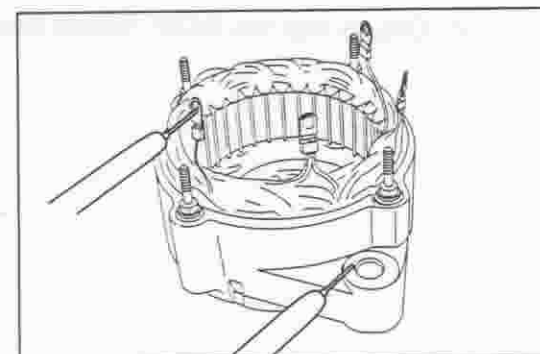

JCH00038-00033

Brush and brush holder

1. Measurement of exposed brush length
Measure the exposed brush length, using a scale.

Standard Exposed Length: 10.5 mm

Minimum Exposed Length: 8.4 mm

If the exposed length is less than the minimum requirement, replace the brushes.

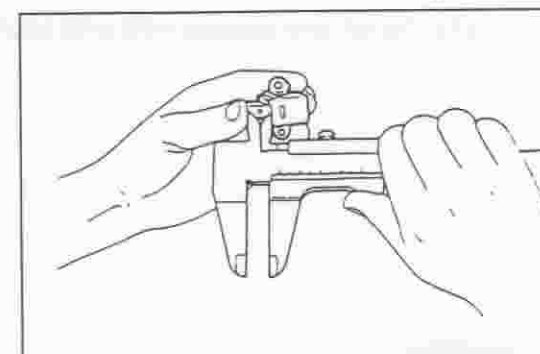

JCH00039-00034

2. Replacement of brushes
(1) Remove the brush and spring from the brush holder by melting the solder by means of a soldering iron.

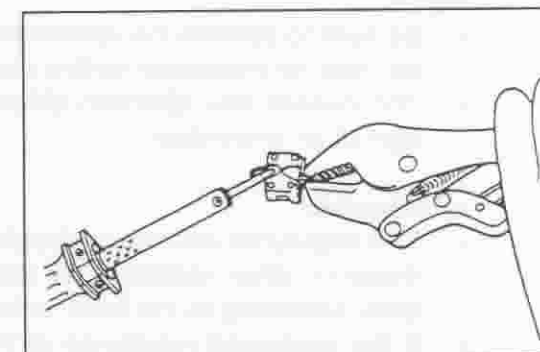

JCH00040-00035

- (2) Install the brush cord in the brush holder with the spring fitted in place.

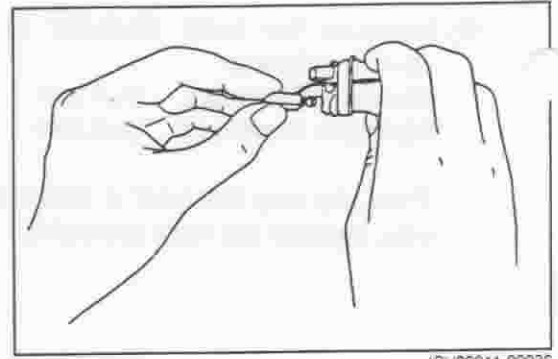

JCH00041-00036

- (3) Solder the brush cord in the brush holder in such a way that the exposed length of the brush meets the specification.
Standard Exposed Length: 10.5 mm

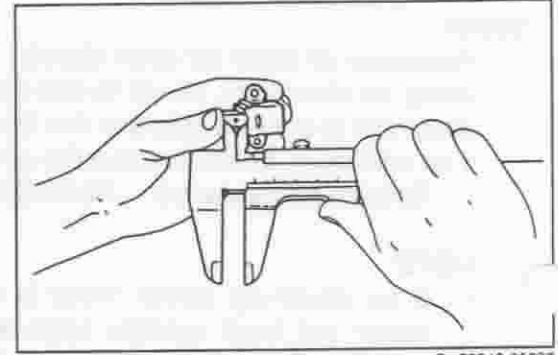

JCH00042-00037

- (4) Ensure that the brush moves freely in the brush holder.

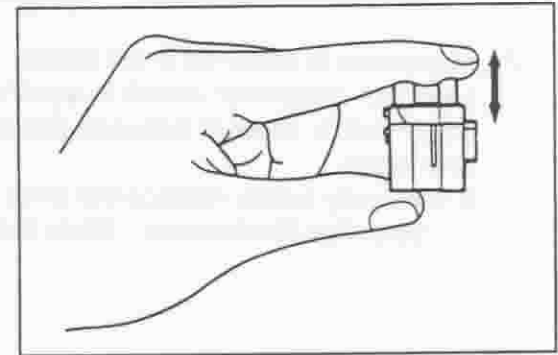

JCH00043-00038

- (5) Cut off any excess wire and apply insulation paint.

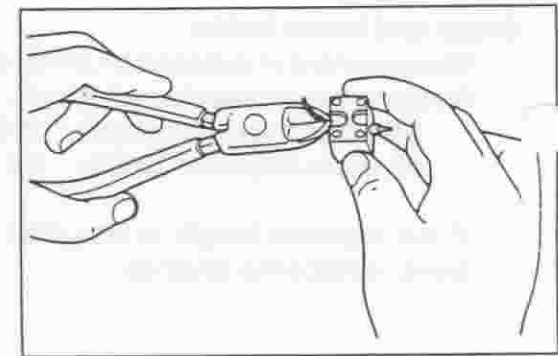

JCH00044-00039

Rectifier

NOTE:

- Be sure to confirm the specification of the ohmmeter to be used for inspection before putting it into use.
- The current flow direction differs according to the design of an ohmmeter.

<Reference>

- The measured resistance should be about the same as those of other rectifiers, for the measurement results differ according to the input voltage of each tester.
- If the measured resistance of the rectifier differs more than 20 percent, replace the rectifier holder.

JCH00045-00040

1. Inspection of rectifier at positive side

- (1) While using an ohmmeter, connect one tester probe to the positive terminal. Also, connect the other probe to each of the rectifier terminals.

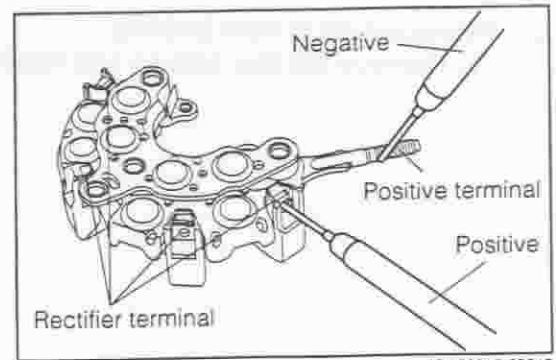

JCH-00046-00040

- (2) Repeat the same steps described in (1) above with the polarity of the tester probes reversed this time.
- (3) Ensure that continuity exists either in the step (1) or in the step (2) and no continuity exists at the other test. If not, replace the rectifier holder.

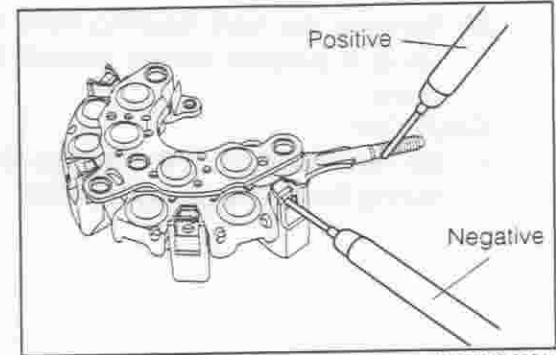

JCH-00047-00041

2. Inspection of rectifier at negative side

- (1) While using an ohmmeter, connect one tester probe to each negative terminal. Also, connect the other probe to each rectifier terminal.

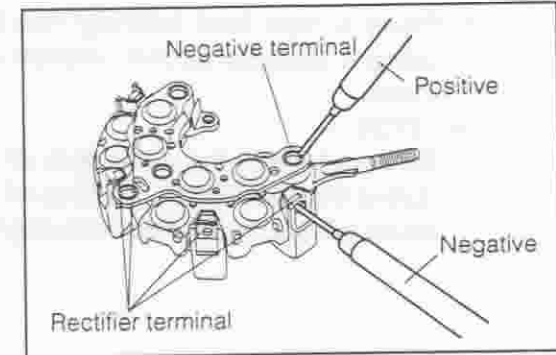

JCH-00048-00042

- (2) Repeat the same steps described in (1) above with the polarity of the tester probes reversed this time.
- (3) Ensure that continuity exists either in the step (1) or in the step (2) and no continuity exists at the other test. If not, replace the rectifier holder.

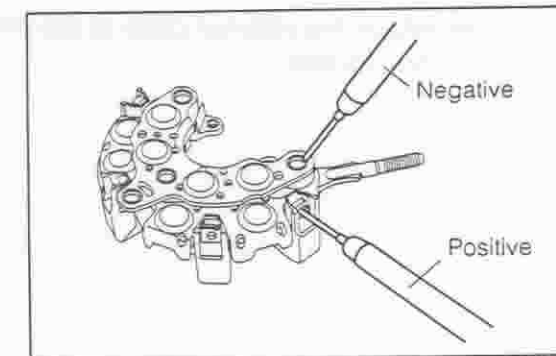

JCH00049-00043

Bearing

1. Inspection of front bearing

- Ensure that the front bearing turns smoothly.
Replace the front bearing, if necessary.

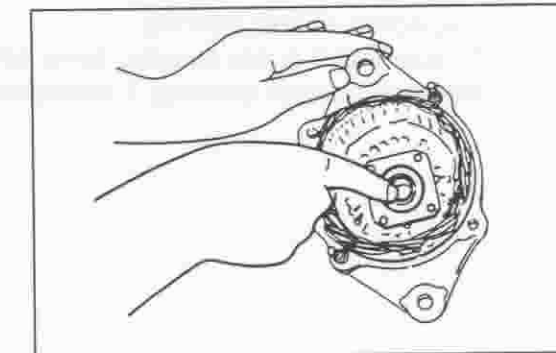

JCH00050-00044

2. Replacement of front bearing

(1) Remove the four screws and retainer plate.

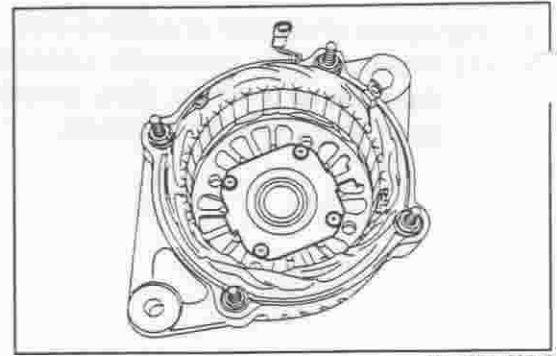

(2) Remove the front bearing from the drive end frame, using a suitable socket wrench in conjunction with a press.

CAUTION:

- Be very careful not to damage the coil and stud bolts during the front bearing removal.

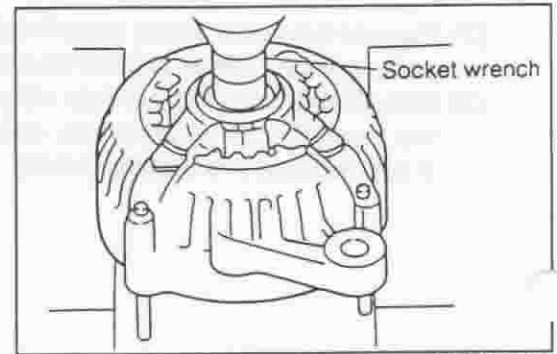

(3) Press a new front bearing into the drive end frame, using a suitable socket wrench in conjunction with a press.

CAUTION:

- Be sure to hold the outer race of the new front bearing during the installation. Holding of the inner race or side cover will cause the front bearing to be damaged.

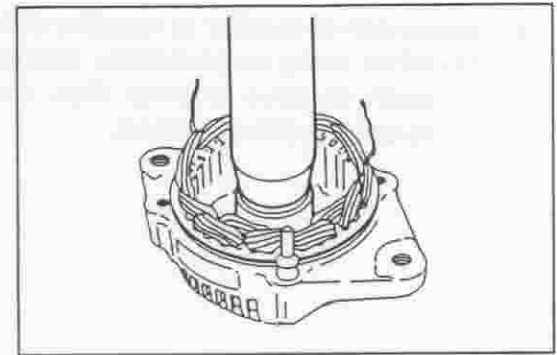

(4) Attach the retainer plate to the drive end frame with the four screws.

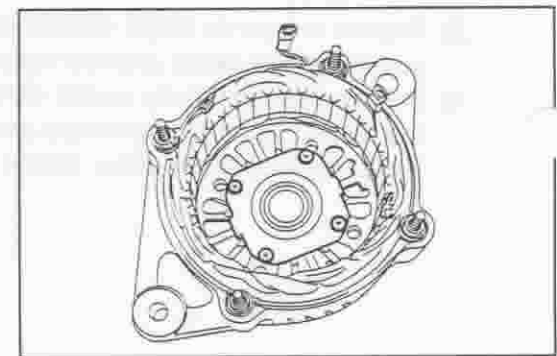

3. Inspection of rear bearing

Ensure that the rear bearing turns smoothly.
Replace the rear bearing, if necessary.

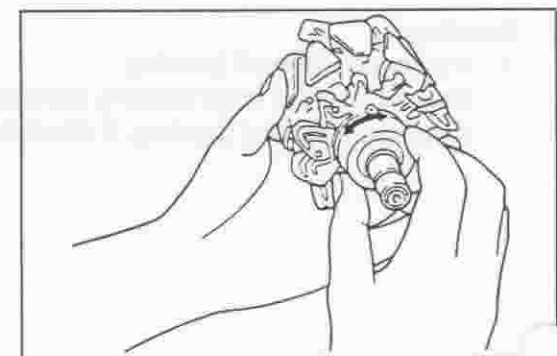

4. Replacement of rear bearing

(1) Remove the rear bearing cover from the rotor, using an armature bearing puller.

CAUTION:

- Be very careful not to damage the fan during the removal.

SST: 09820-00021-000

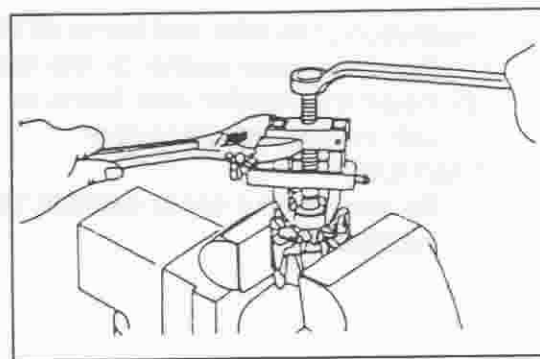

JCH00056-00050

(2) Place the parts on the rotor in the following order.

- Spacer
- New rear bearing
- New bearing cover

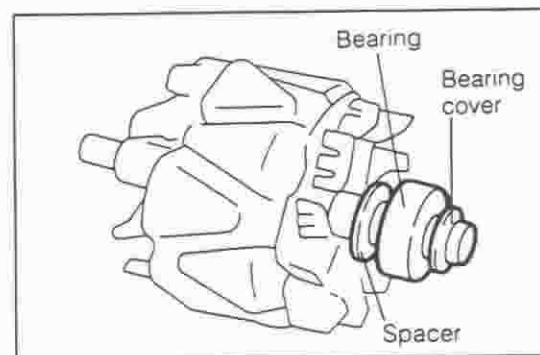

JCH00057-00051

(3) Press the assembled parts into the rotor, using a hydraulic press in combination with a suitable attachment.

NOTE:

- Care must be exercised so that the point where the rear bearing is assembled to the rotor shaft may not deform an bearing cover. Therefore, be sure to select a suitable attachment to assemble the bearing cover.

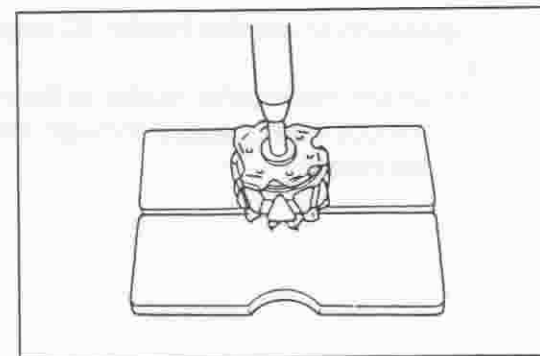

JCH00058-00052

5. Inspection/replacement of stud bolt

Visually inspect the thread portion of the stud bolt. If any damage exists, replace the stud bolt.

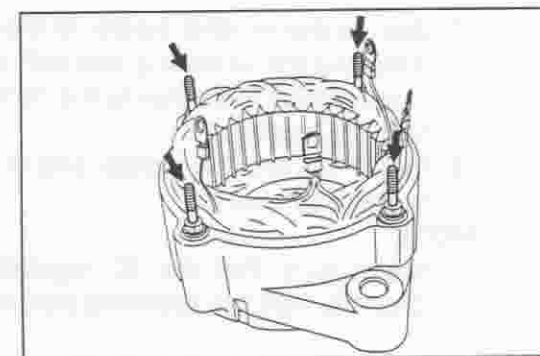

JCH00059-00053

ASSEMBLY

1. Install the rotor in the drive end frame assembly.

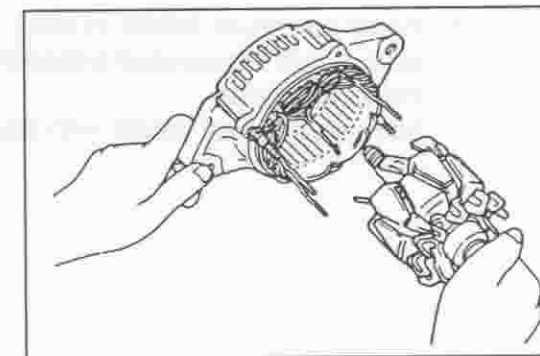

JCH00060-00054

2. Installation of rectifier end frame on drive end frame
- (1) Place the wave washer on the rear bearing.
 - (2) Install the rectifier end frame on the drive end frame with the four attaching nuts.

CAUTION:

- Be very careful not to damage the coil cord during the installation.

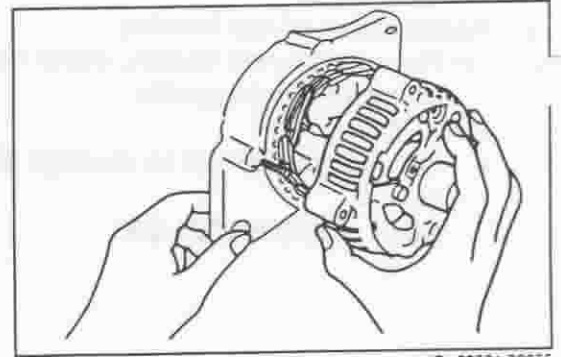

JCH-00061-00055

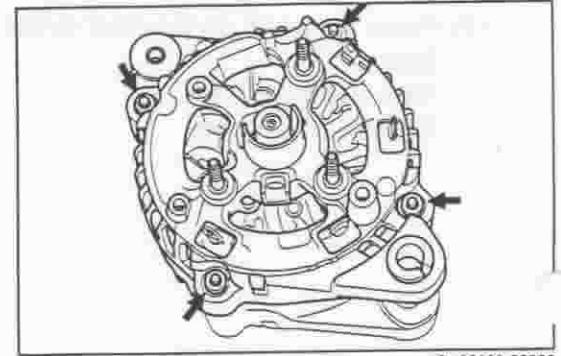

JCH-00000-00056

3. Installation of rectifier holder, IC regulator and brush holder

- (1) Attach the rectifier holder to the rectifier end frame with the coil wires passed through the aperture of the rectifier holder.

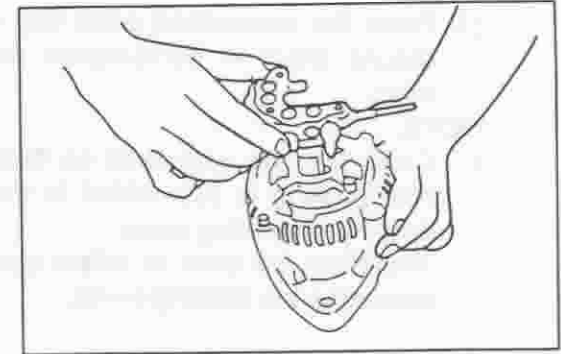

JCH-00062-00057

- (2) Secure the rectifier holder to the rectifier end frame by installing the attaching bolt with washer.
- (3) Connect the coil wires to the rectifier holder with the attaching screws.
- (4) Install the rectifier holder and IC regulator with the attaching screws.

NOTE:

- Make sure that the IC regulator has been installed properly with the attaching screws.

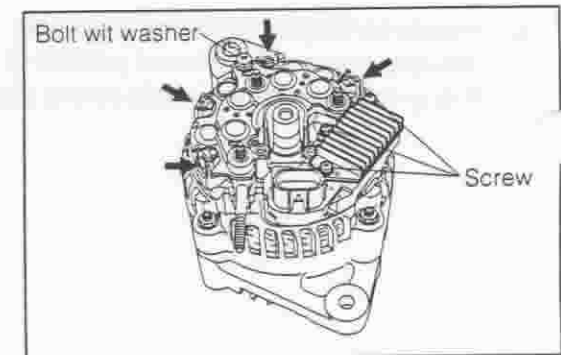

JCH-00064-00059

- (5) Install the brush holder in such a way that a gap of at least 1 mm is provided between the brush holder and the IC regulator.
Secure the brush holder with the two screws.

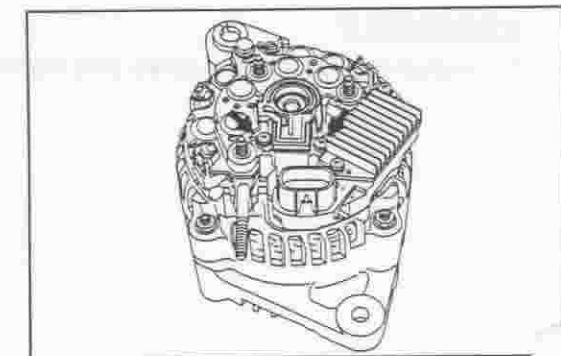

JCH-00065-00

4. Installation of rear end cover.

- (1) Install the rear end cover on the alternator.
- (2) Secure the rear end cover with the three attaching nuts.
- (3) Install the insulator terminal.
- (4) Secure the insulator terminal attaching nut.

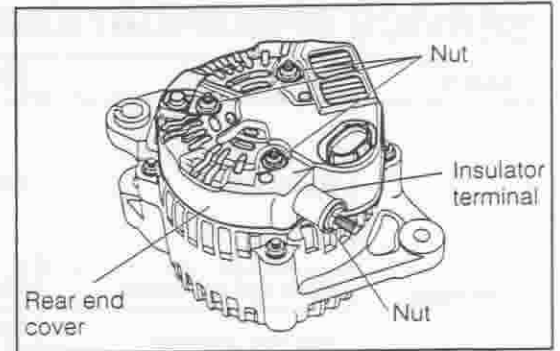

JCH00066-00061

5. Attach the alternator pulley and spacer collar to the rotor shaft.

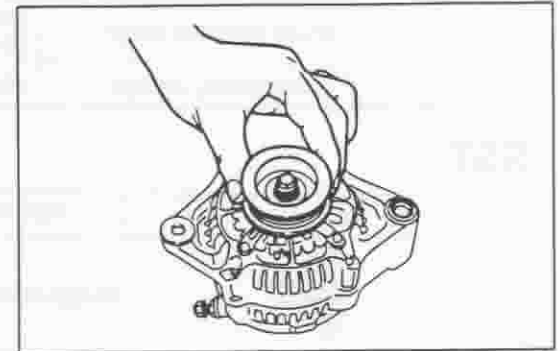

JCH00067-00062

6. Tighten the pulley lock nut to the specified tightening torque.

Tightening Torque: 94.0 - 127.0 N·m

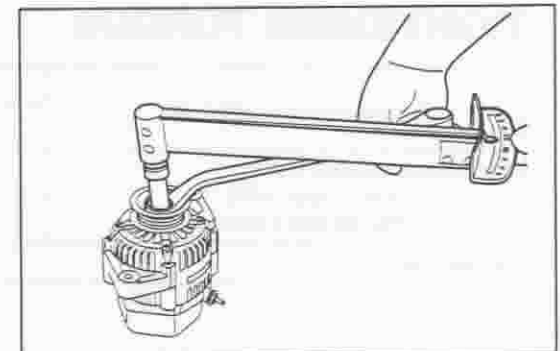

JCH00068-00063

7. Ensure that the rotor turns smoothly.

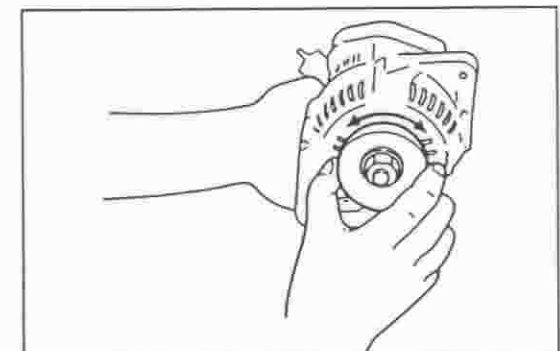

JCH00069-00064

SERVICE SPECIFICATIONS

Battery	Specific gravity	Standard	1.25 - 1.28	
Alternator:	Rated output	Amperage	M101, M111	70 A
			J102, J122 (Except tropical, general and A/T specifications)	
			J102, J122 (Tropical, general and A/T specifications)	
	Rotor coil resistance	Resistance	2.9 Ω at 20°C (68°F)	
	Slip ring diameter	Standard Minimum	14.4 mm 14.0 mm	
Brush exposed length	Standard	10.5 mm		
	Minimum	8.4 mm		
IC regulating voltage	Adjusting voltage	14.2 - 14.8 volts		

JCH-00070-00000

SST

Shape	Part No.	Part name
	09820-00021-000	Alternator bearing puller

JCH-00071-00005

TIGHTENING TORQUE

Tightening components	Tightening torque	
	N·m	kgf-m
Alternator attaching bolt		
Bolt (upper side)	15.2 - 22.8	1.6 - 2.3
Flange bolt (lower side)	35.2 - 52.8	3.6 - 5.4
Pulley lock nut	94.0 - 127.0	9.6 - 13.0

JCH-00072-00000