

HARNES & WIRING DIAGRAM

GENERAL DESCRIPTION	HW- 2	TAIL LAMP & LICENSE PLATE	
HANDLING PRECAUTION	HW- 2	LAMP (CONNECTORS)	HW-31
WIRE SIZE & COLOR CODE	HW- 3	HAZARD WARNING & TURN SIGNAL	
INSPECTION	HW- 4	LAMP (LHD)	HW-32
OPERATION OF LOCK TYPE		HAZARD WARNING & TURN SIGNAL	
CONNECTOR	HW- 6	LAMP (RHD)	HW-33
TERMINAL REMOVAL &		HAZARD WARNING & TURN SIGNAL	
INSTALLATION	HW- 6	LAMP (CONNECTORS)	HW-34
WIRING DIAGRAM	HW- 7	DAYLIGHT	HW-35
POWER SUPPLY (LHD)	HW- 7	DAYLIGHT (CONNECTORS)	HW-36
POWER SUPPLY (RHD)	HW- 8	HEATER & VENTILATION (LHD)	HW-37
EFI (LHD)	HW- 9	HEATER & VENTILATION (RHD)	HW-38
EFI (LHD/LEADED)	HW-10	POWER WINDOW (LHD)	HW-39
EFI (RHD)	HW-11	POWER WINDOW (RHD)	HW-40
EFI (CONNECTORS)	HW-12	WIPER & WASHER (LHD)	HW-41
ABS SYSTEM (LHD)	HW-13	WIPER & WASHER (RHD)	HW-42
ABS SYSTEM (RHD)	HW-14	WIPER & WASHER (CONNECTORS)	HW-43
ABS SYSTEM (CONNECTORS)	HW-15	DEFOGGER (LHD)	HW-44
A/T ECU (LHD)	HW-16	DEFOGGER (RHD)	HW-45
A/T ECU (RHD)	HW-17	CIGARETTE LIGHTER, HORN, RADIO	
A/T ECU (CONNECTORS)	HW-18	(LHD)	HW-46
DIFFERENTIAL LOCK SYSTEM	HW-19	CIGARETTE LIGHTER, HORN, RADIO	
HEADLAMP (LHD)	HW-20	(RHD)	HW-47
HEADLAMP (RHD)	HW-21	CIGARETTE LIGHTER, HORN, RADIO	
REAR FOG LAMP (LHD)	HW-22	(CONNECTORS)	HW-48
REAR FOG LAMP (RHD)	HW-23	REAR VIEW MIRROR	HW-49
STOP LAMP (LHD)	HW-24	CLOCK	HW-50
STOP LAMP (RHD)	HW-25	ITC 1/2 (LHD)	HW-51
BACK UP LAMP (LHD)	HW-26	ITC 2/2 (LHD)	HW-52
BACK UP LAMP (RHD)	HW-27	ITC 1/2 (RHD)	HW-53
INTERIOR LAMP	HW-28	ITC 2/2 (RHD)	HW-54
TAIL LAMP & LICENSE PLATE LAMP		ITC (CONNECTORS)	HW-55
(LHD)	HW-29	IMMOBILIZER SYSTEM	HW-56
TAIL LAMP & LICENSE PLATE LAMP		SRS AIR BAG SYSTEM (LHD)	HW-57
(RHD)	HW-30	SRS AIR BAG SYSTEM (RHD)	HW-58
		LOCATION OF CONNECTOR	HW-59

JHW00001-00000

HW-2

GENERAL DESCRIPTION

HANDLING PRECAUTION

General instructions

1. Never pull the connectors or step on them during the wire harness transport or assembly.
(Prevention of pulling-out of terminals, connector cracks, deformation and so forth)
2. Care must be exercised to ensure that no scratch is made to the wire harness by burrs or edges during the wire harness transport or assembly.
(Prevention of scratches to the outer trim, electrical insulators and so forth)

3. Clamping method

In the case of resin clamps, ensure that the clamp section is fitted in the body hole.

NOTE:

- Ensure that the clamp will not be detached when it is pulled lightly in the arrow-headed direction.
(Prevention of interference due to the detachment of the clamp)
- In the case of metal sheet welded clamps, be sure to assemble the harness in such a way that the harness will not come in contact with the welded surface.
(Prevention of wire harness damage due to welding burrs)
- In case that the locating guide of the clamp position or the clamp mark is clamped, make sure that the clamp is located within the guide. As for the clamp at the clamp mark section, ensure that the clamping is made at a point within ± 10 mm.
(Prevention of slackness or interference)

4. Terminals and connectors

- Perform the connection of connectors positively.
 - Connector with lock Ensure that the locking is made.
 - Connector without lock Connect the connector positively until it stops.

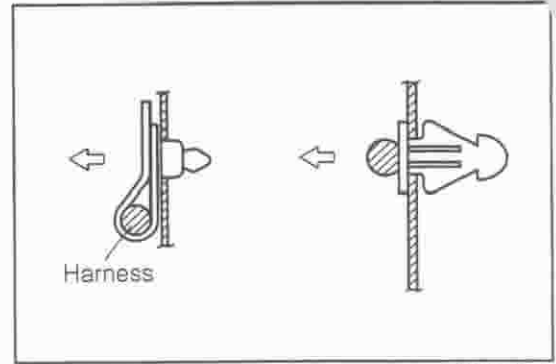

JHW00002-00001

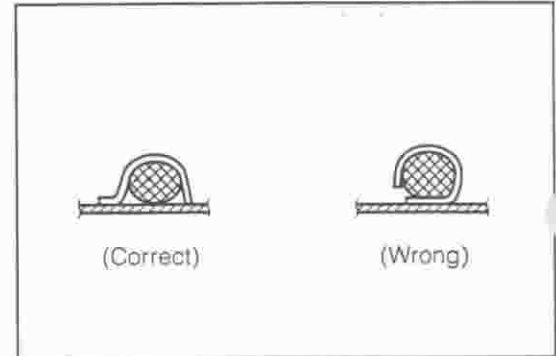

JHW00003-00002

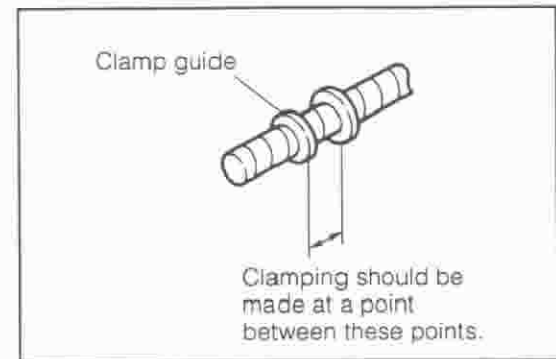

JHW00004-00003

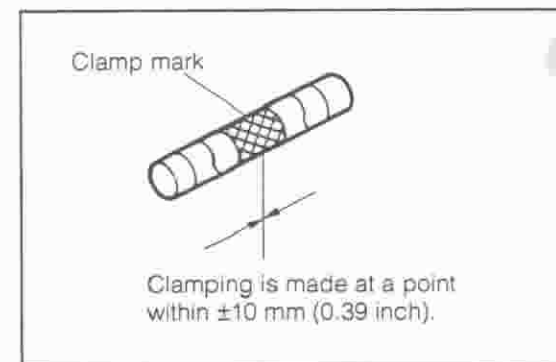

JHW00005-00004

JHW00005-00005

- Retention by screws
 - When the tightening torque is specified, be sure to observe the specification strictly. (The tightening torque is posted in the table separately.)
 - Ensure that the staked section may not come on the assembling surface.
 - After completion of the tightening operation, lightly pull out the terminal. Ensure that there is no slackness.
 - When performing other operations, care must be exercised to ensure that no connected connector is detached by pulling out the wire harness forcibly.
5. Work procedure for tightening-up type resin clamps
 When the tightening-up type resin clamps are employed, do not use any pliers, cutting pliers or the like.
 <Reason>
 Prevention of clamps being cut or scratched.

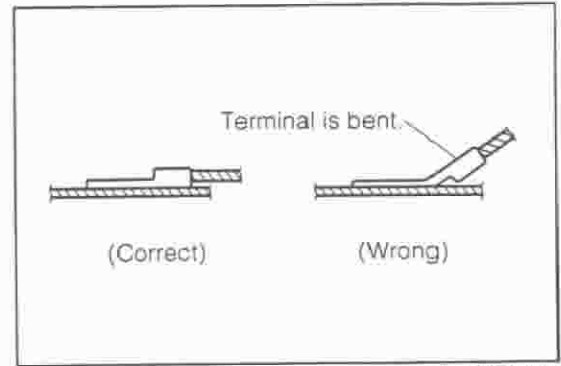

JHW00006-00005

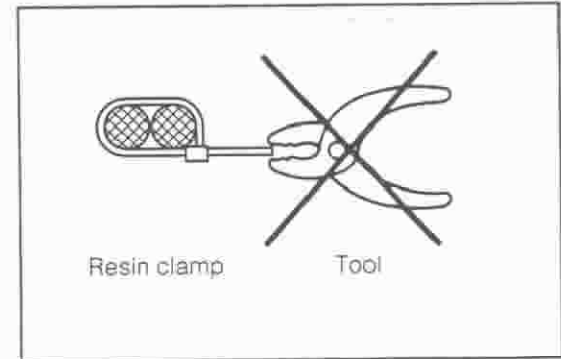

JHW00007-00006

WIRE SIZE & COLOR CODE

- For identification purpose, each wire has its own color. Each color bears a code as described in the right table. These codes are used in the wiring diagram and will be helpful during trouble shooting.

Code	Gr	Br	B
Color	Gray	Brown	Black
Code	W	R	G
Color	White	Red	Green
Code	Y	L	O
Color	Yellow	Blue	Orange
Code	P	Lg	V
Color	Pink	Light green	Violet

JHW00008-00000

- The wire color comes in two kinds: single color and composite color. In the case of single color, the whole outer coat of the harness is of a single color. In the case of composite color, a fine line of the second color is drawn on the harness basic color. In this case, the code is composed of the basic color code which comes first and the second color code which comes after a hyphen.

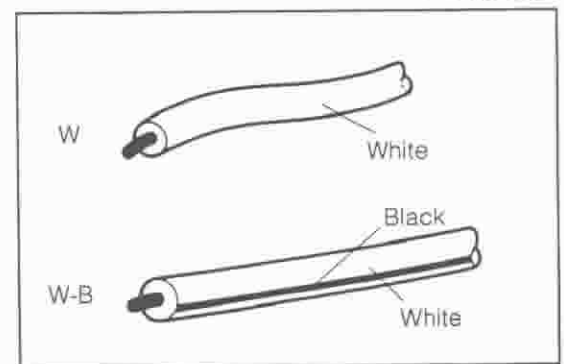

JHW00009-00007

WARNING:

- The wire diameter and capacity of each harness have been determined to assure the normal operation of the electrical system.
- Hence, do not take power for accessories carelessly through the original wiring harness. Failure to observe this caution may cause system malfunction or fire.

JHW00010-00000

HW-4

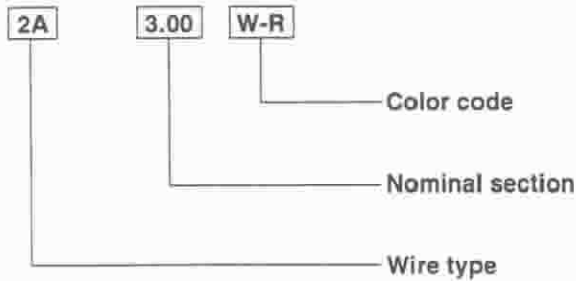

JH-W00011-00000

Nominal section	Section area (mm)	Diameter (mm)	Permissible current (A)
0.5	0.56	1.0	9
0.85	0.88	1.2	12
1.25	1.28	1.5	15
2.00	2.09	1.9	20
3.00	3.29	2.4	27

JH-W00012-00000

INSPECTION

Tester (Volt/ohmmeter)

For the inspection, use a tester having an internal resistance of more than 10 kilo-ohms/V.

Use of a tester with a low internal resistance may cause wrong measurement or secondary troubles.

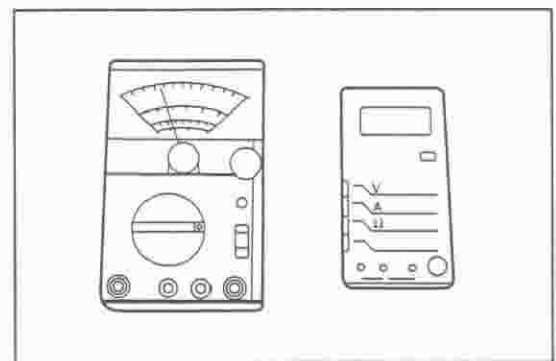

JH-W00013-00008

Conventional type connector

When resistance measurement and/or voltage measurement is conducted at the connector section, insert the measuring probe from the back of the connector, being very careful not to damage the harness-to-terminal connections.

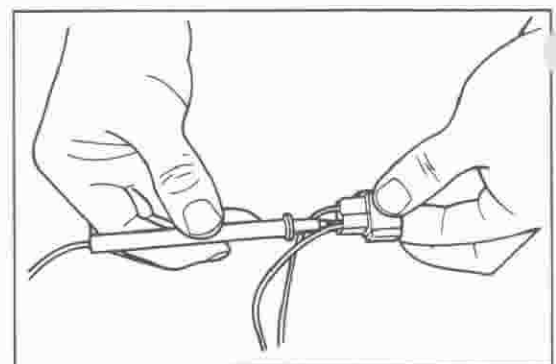

JH-W00014-00009

Water-proof type connector

When resistance measurement and/or voltage measurement is conducted at the connector section, bring the measuring probe into contact with the terminal at the connection side of the connector.

Be very careful not to apply excessive force to the terminal at the connector side. Failure to observe this caution may deform the terminal, causing poor continuity.

As an alternative method, insert a male or female terminal into the connector terminal or connect an adequate attachment.

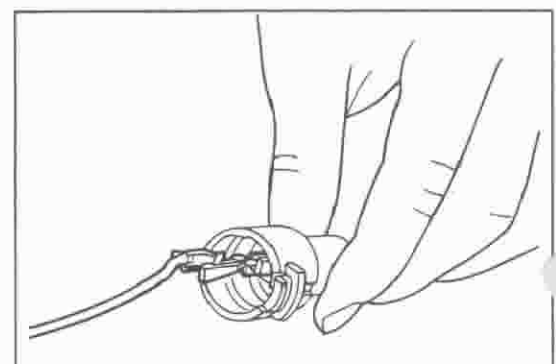

JH-W00015-00010

INSPECTION OF CIRCUIT WITH TESTER

If a diode is built in the circuit, perform continuity test by changing the polarities of the measuring terminals. In case of a general type tester, ensure that continuity exists when the negative (-) lead of the tester is connected to the positive (+) side of the diode; the positive (+) lead of the tester to the negative (-) side of the diode. Also ensure that no continuity exists when the polarities are changed.

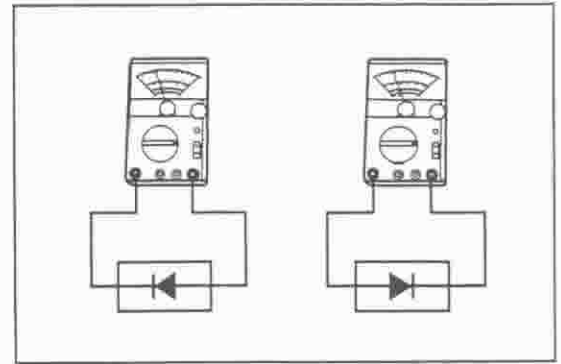

JHW00016-00011

Since some testers have different polarities, be sure to read the instruction manual of a tester to be used for the check before using it.

JHW00017-00000

The inspection procedure for light emitting diodes (LED) is the same as normal diodes. However, there may be cases where the LED emits no light, unless a tester with LED check mode is used. If an adequate tester is not available, apply the battery voltage to the LED and ensure that the LED emits light.

JHW00018-00000

INSPECTION OF SHORT CIRCUIT

1. Remove a melt fuse or fusible link.
2. Disconnect all connectors for loads being applied to the melt fuse.
3. Connect a test lamp at the position where the melt fuse or fusible link was installed.
4. Search for the short circuit by providing the minimum conditions which make the test lamp glow.
5. Perform repairs or wiring harness replacement, as required.

Example

Short section	Connecting conditions
(A)	Ignition switch is turned ON.
(B)	Ignition switch and switch A are turned ON.
(C)	Ignition switch, switch A and switch B are turned ON with relay energized.

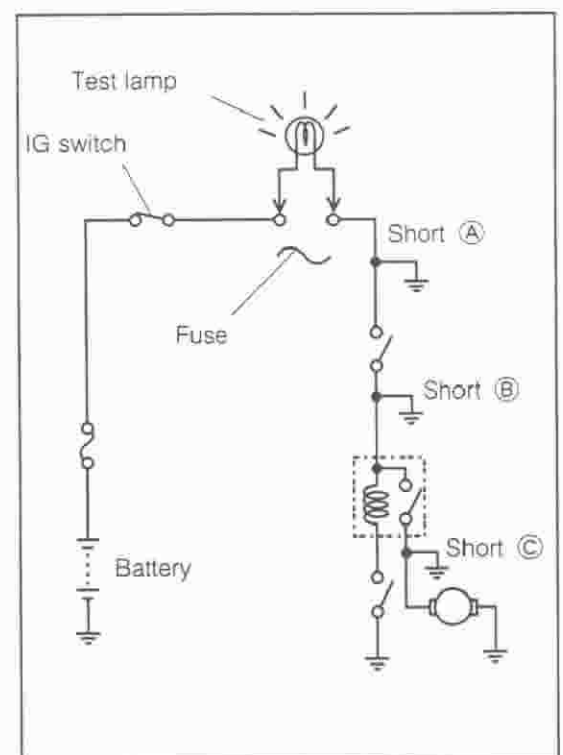

JHW00019-00012

HW-6

OPERATION OF LOCK TYPE CONNECTOR

Disconnection

The lock type of the connector comes in a push release type, a pull release type, a spring lock type, an one-way lock type and so on.

After confirming the shape of the lock, unlock the lock. Disconnect the connector while holding the connector by hand.

NOTE:

- Never pull the harness during the disconnection.
- Be sure to pull out the connector straight so as not to damage the terminal.

Connection

Perform the connection until the lock is completely engaged. After the connection has been made, ensure that the lock is engaged positively.

NOTE:

- Be sure to connect the connector straight so as not to damage the terminal.

NOTE:

- Disconnection and connection of each connector should be kept at a minimum level. If unnecessary disconnection or connection is repeated, it may cause unexpected troubles such as poor continuity and chattering.

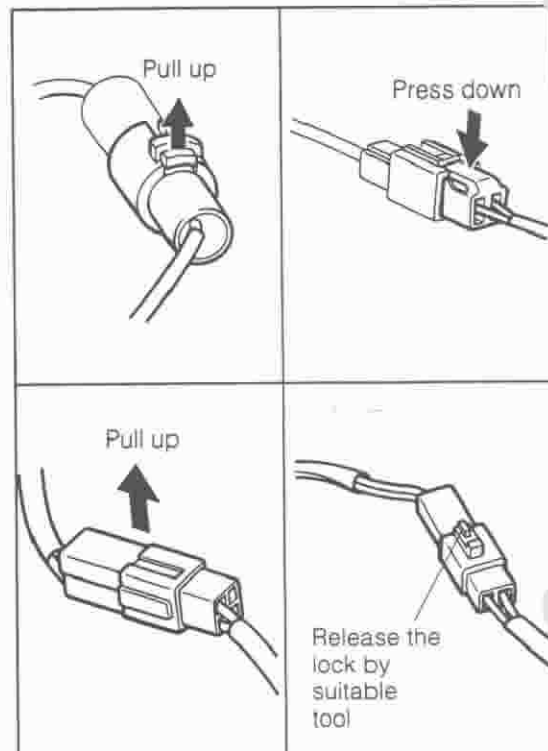

JHW00020-00013

JHW00021-00000

TERMINAL REMOVAL & INSTALLATION

Removal of terminal

<Housing lance type>

Insert a miniature screwdriver through the opening section of the connector into between the locking lug and the terminal. While prying up the locking lug with the screwdriver, pull the terminal backward.

<Metal lance type>

While pushing the lance with the screwdriver, pull the terminal backward.

Installation of terminal

<Housing lance type>

Push the terminal into the protruding section of the connector, until the lock is engaged completely. Lightly pull the harness to assure that the locking has been made completely.

<Metal lance type>

Insert the terminal into the connector, until lance is locked completely. Lightly pull the harness to assure that the locking has been made completely.

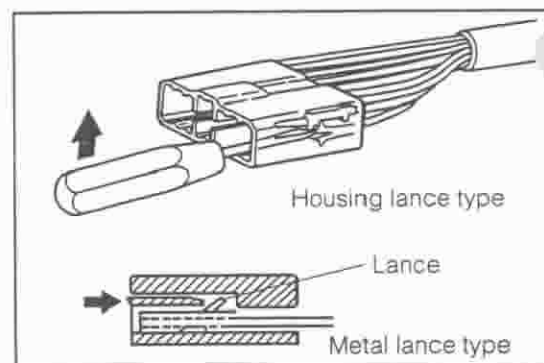

JHW00022-00014

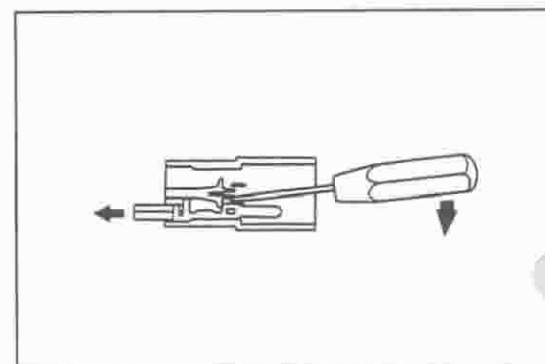

JHW00023-00015

**WIRING DIAGRAM
POWER SUPPLY (LHD)**

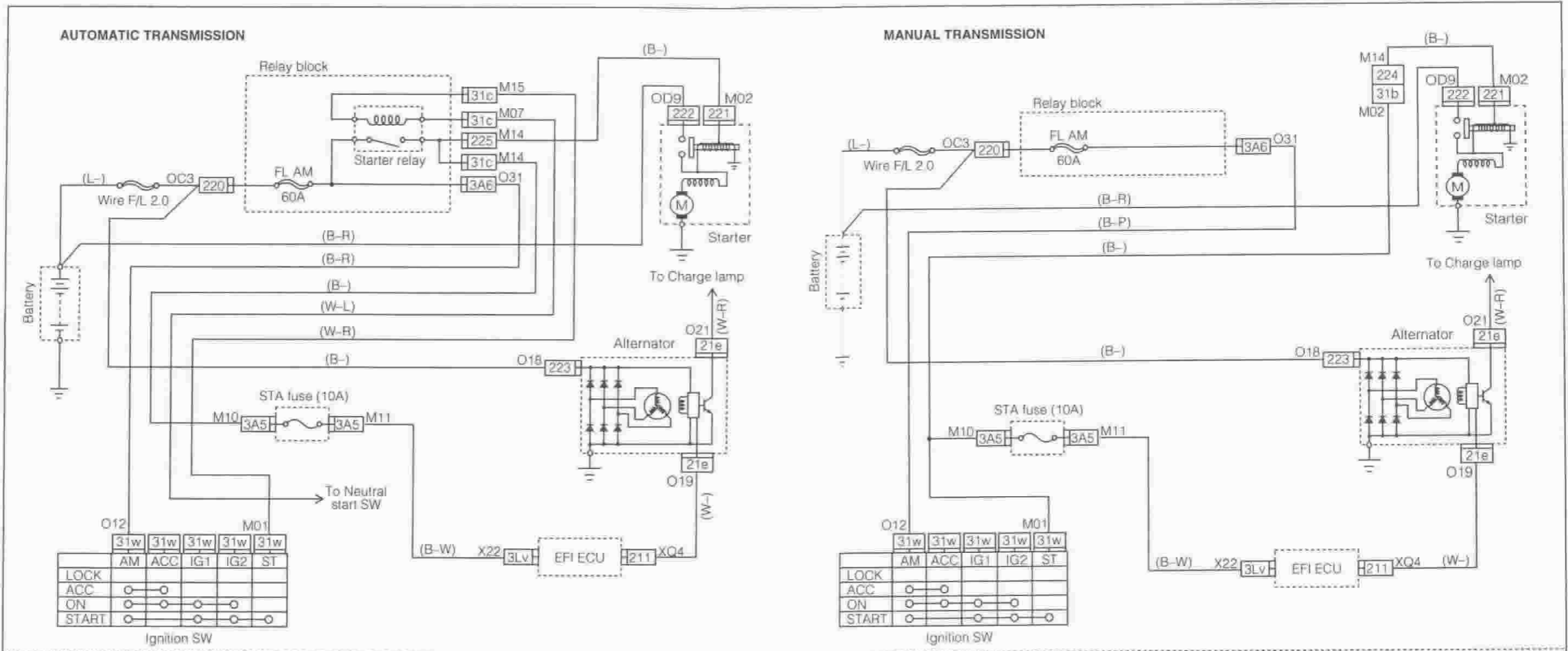

- 220 : Engine wire No. 2 (To relay block F)
- 223 : Engine wire No. 2 (To alternator B)
- 222 : Engine wire No. 2 (To starter B)
- 31c : Cowl wire RH (To relay block B)
- 31w : Cowl wire RH (To ignition SW)
- 211 : Engine wire No. 1 (To EFI ECU A)
- 3Lv : Cowl wire RH (To EFI ECU D)
- 221 : Engine wire No. 2 (To starter A)
- 21e : Engine wire No. 1 (To alternator A)
- 225 : Engine wire No. 2 (To relay block G)
- 3A6 : Cowl wire RH (To relay block E)
- 31b : Cowl wire RH (To engine wire No. 2 [224])
- 3A5 : Cowl wire RH (To sub fuse)
- 224 : Engine wire No. 2 (To cowl wire RH [31b])

POWER SUPPLY (RHD)

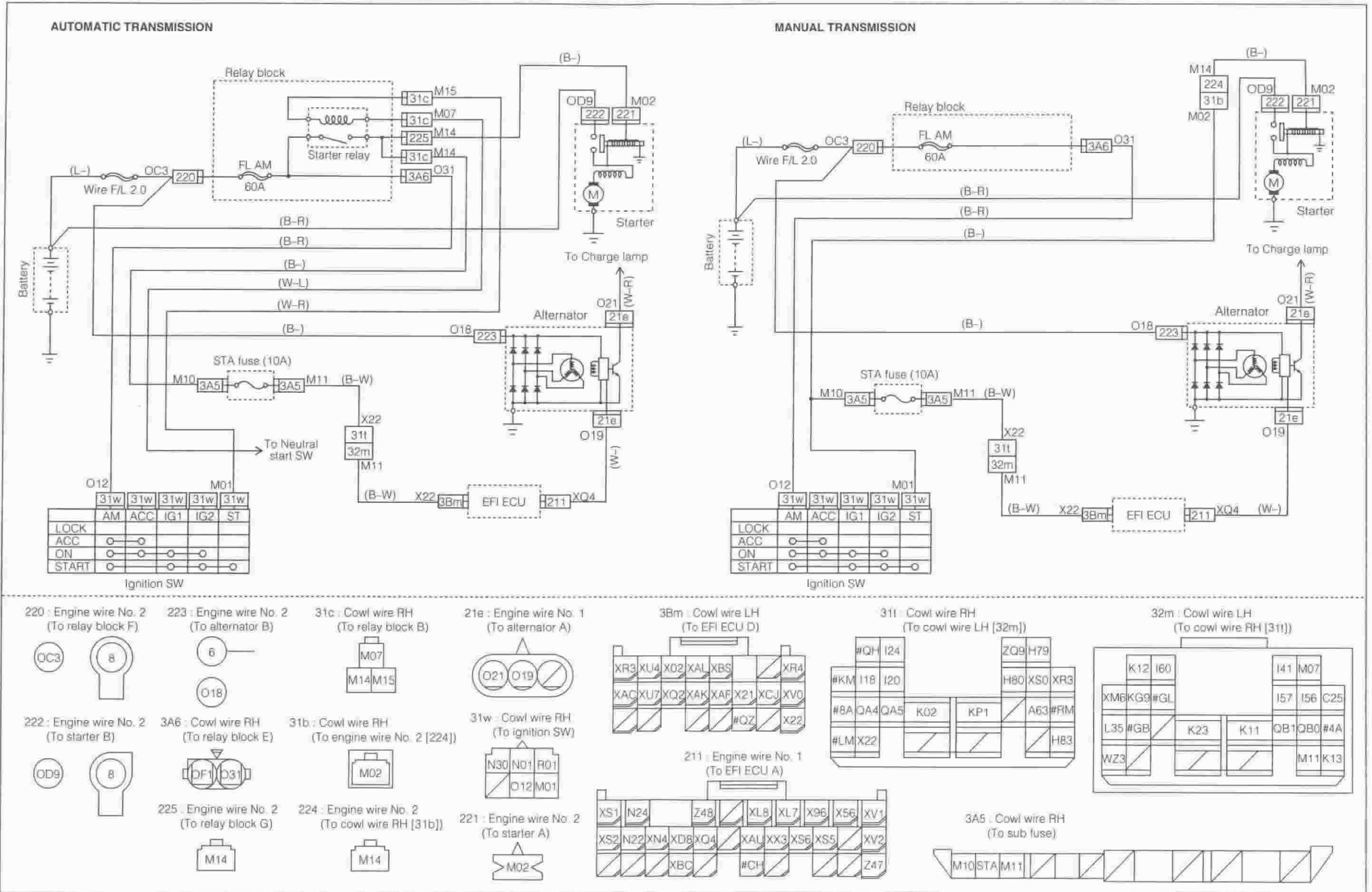

EFI (LHD)

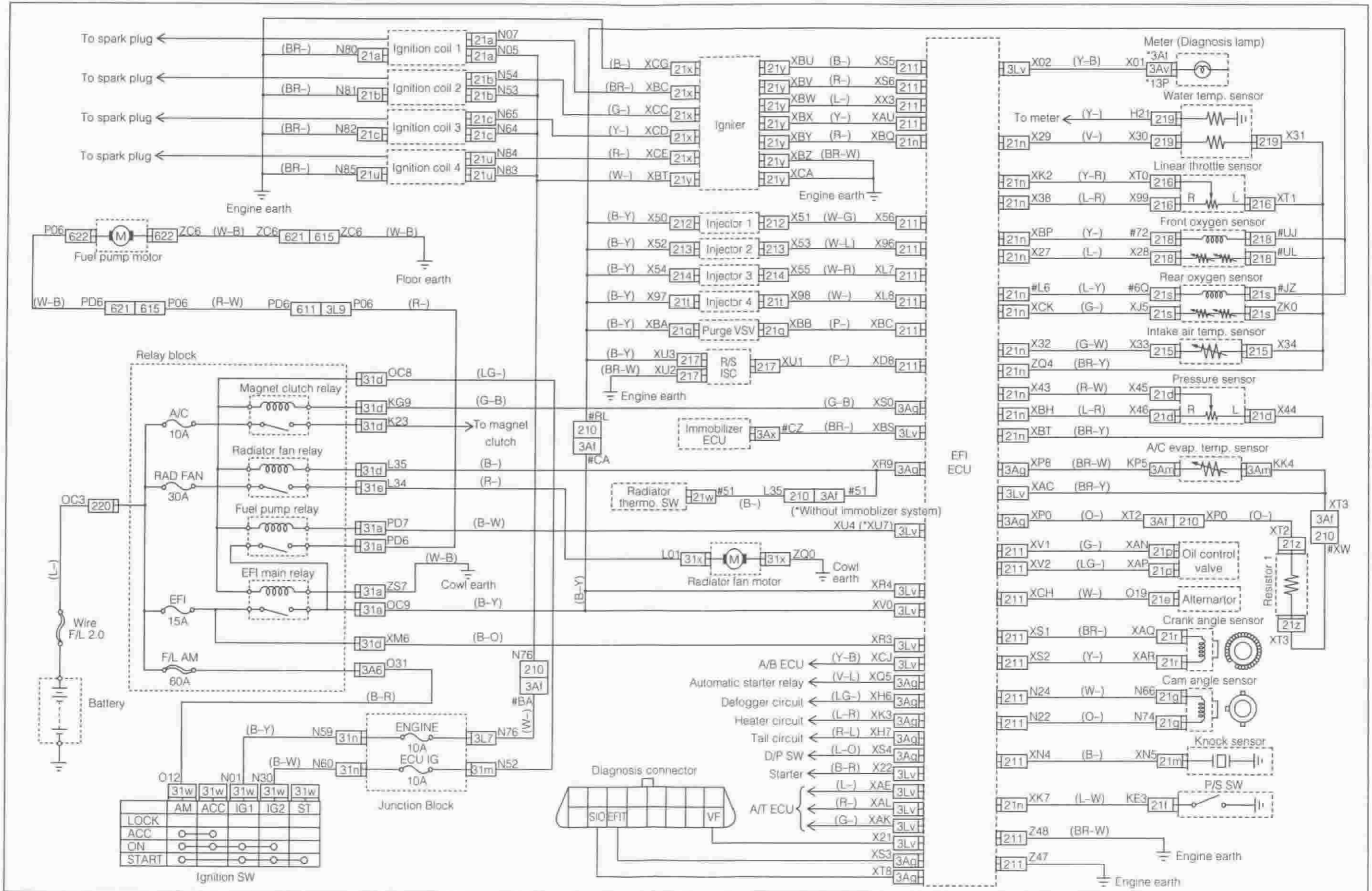

EFI (LHD/LEADED)

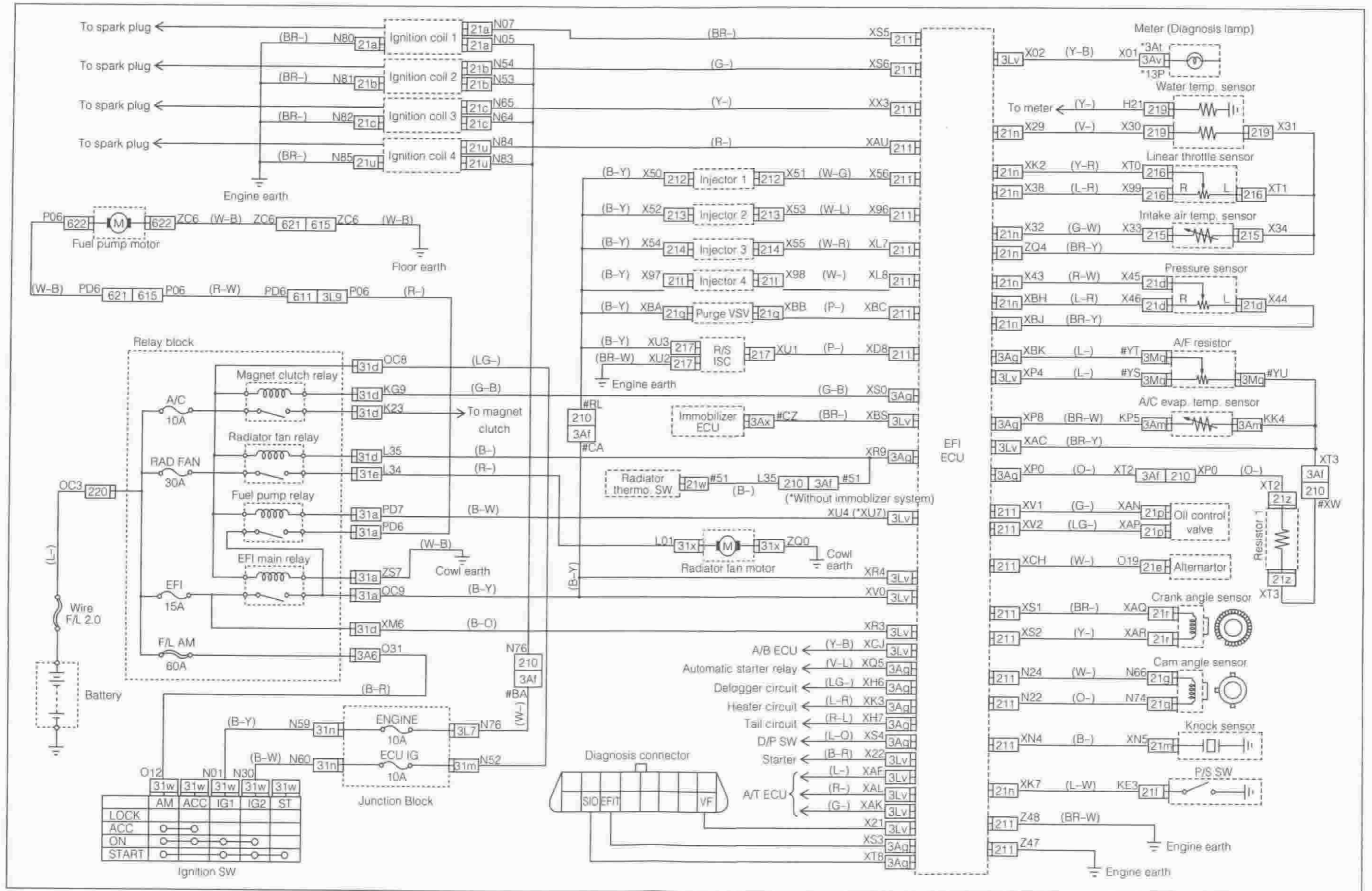

EFI (RHD)

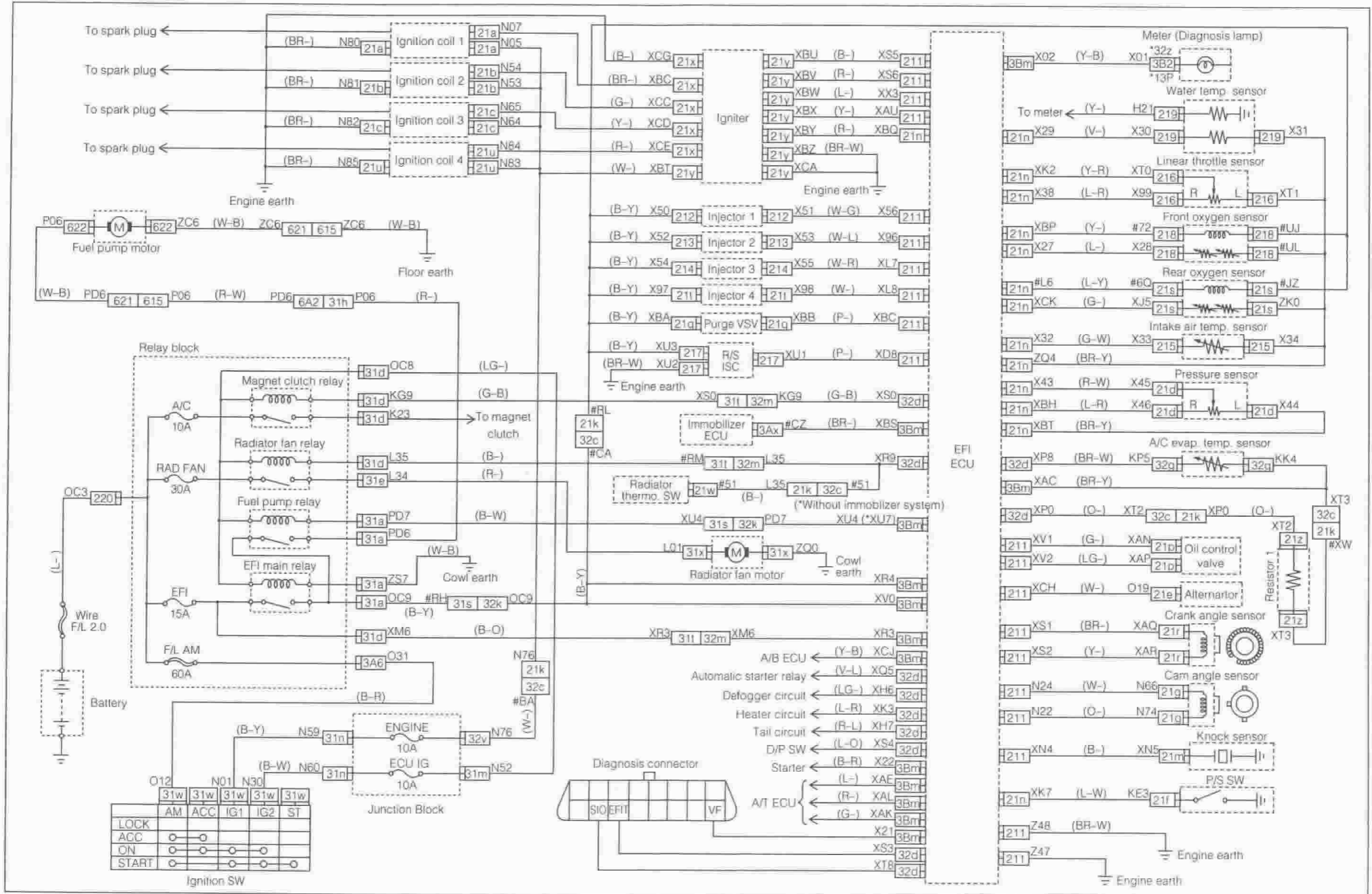

EFI (CONNECTORS)

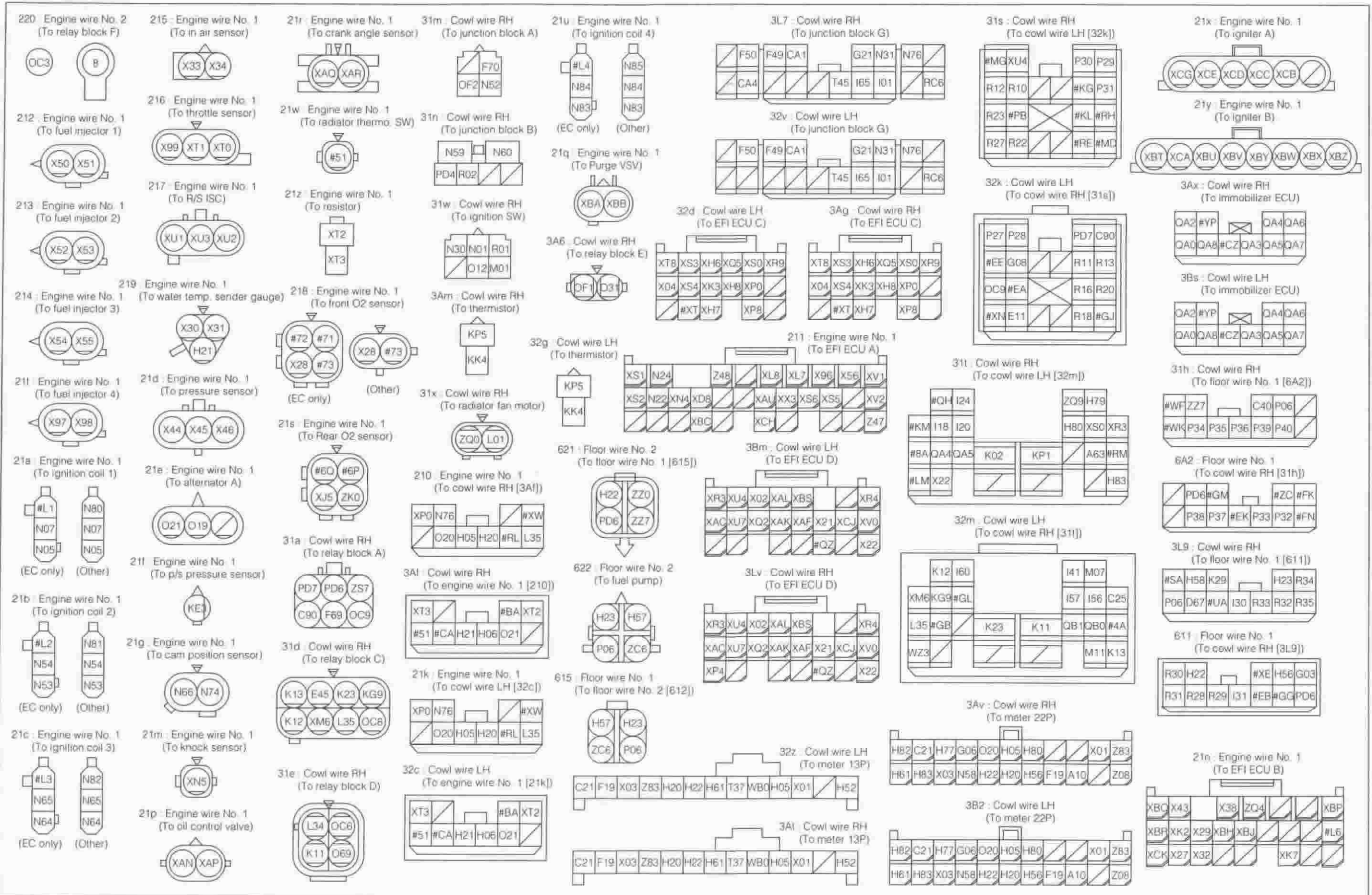

ABS SYSTEM (LHD)

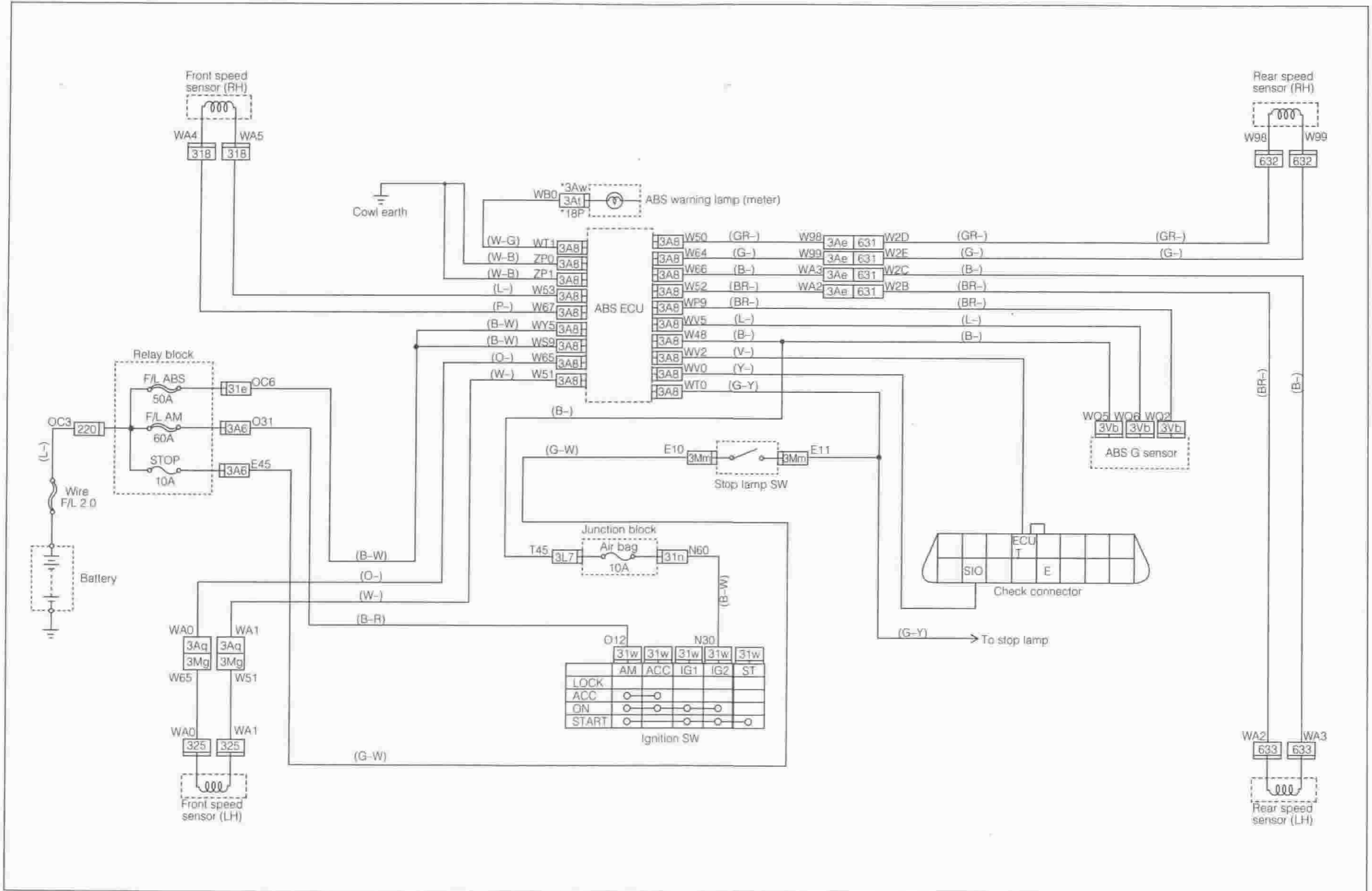

	O12	N30	31w	31w	31w	31w	31w
	AM	ACC	IG1	IG2	ST		
LOCK							
ACC	○	○					
ON	○	○	○	○	○		
START	○	○	○	○	○		

Ignition SW

ABS SYSTEM (RHD)

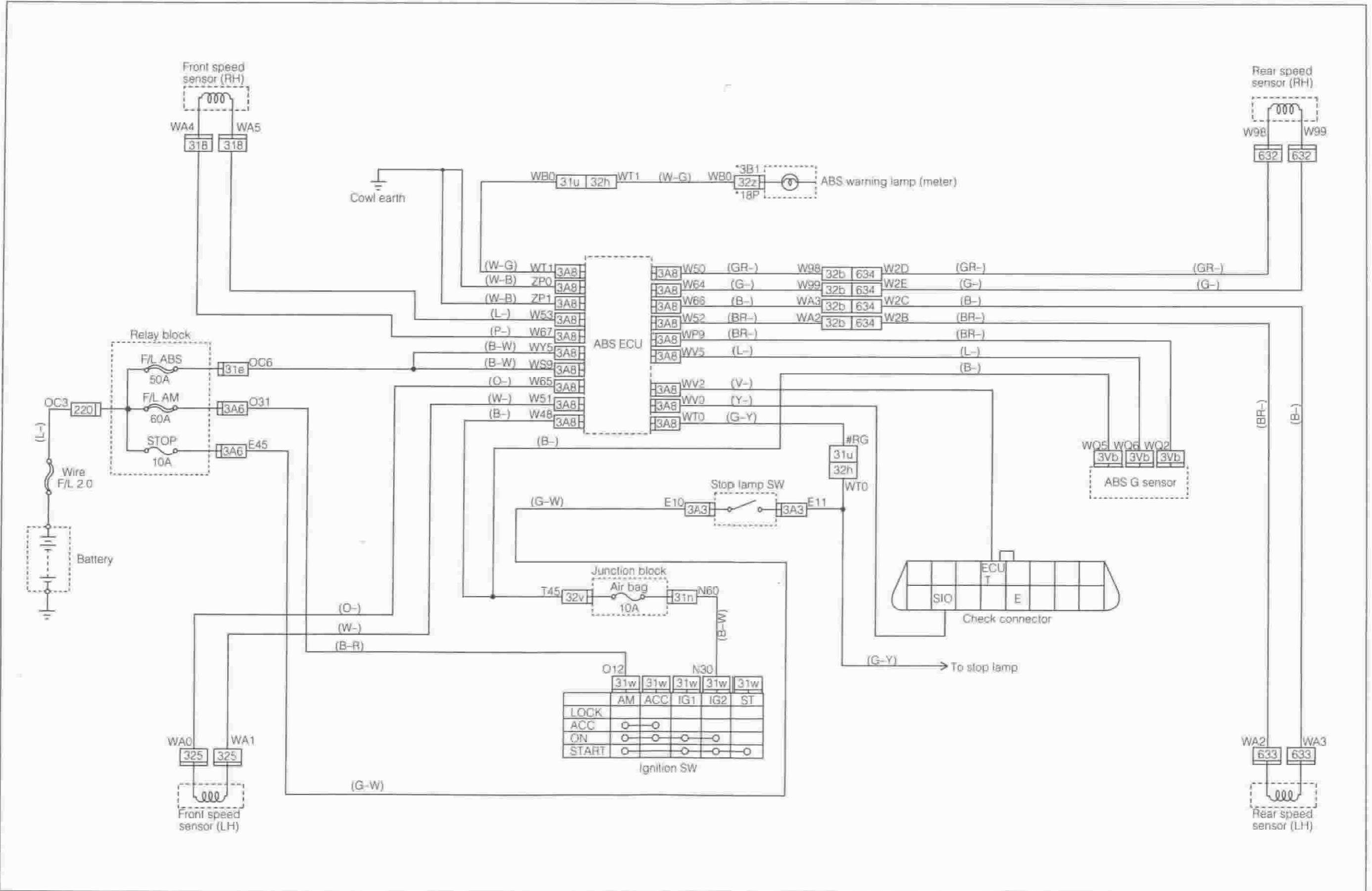

ABS SYSTEM (CONNECTORS)

31B : Cowl wire RH
(To front speed sensor RH)



220 : Engine wire No.2
(To relay block F)

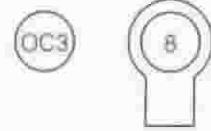

31n : Cowl wire RH
(To junction block B)

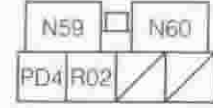

3Mm : Cowl wire LH
(To stop lamp SW)



31w : Cowl wire RH
(To ignition SW)



632 : Floor wire No. 3
(To rear speed sensor RH)



31e : Cowl wire RH
(To relay block D)

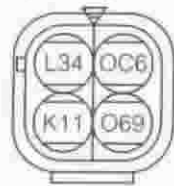

325 : Cowl wire LH
(To front speed sensor LH)



3L7 : Cowl wire RH
(To junction block G)

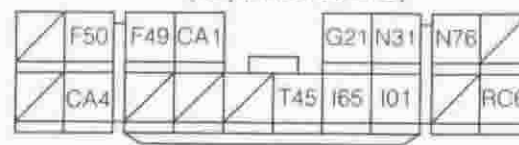

3Ae : Cowl wire RH
(To floor wire No.3 [631])

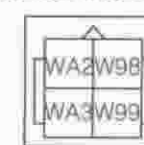

32v : Cowl wire LH
(To junction block G)

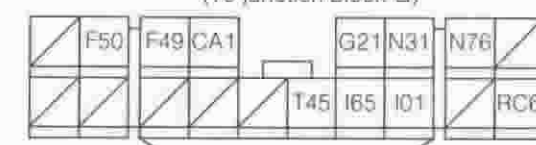

3A6 : Cowl wire RH
(To relay block E)



3At : Cowl wire RH
(To meter 13P)

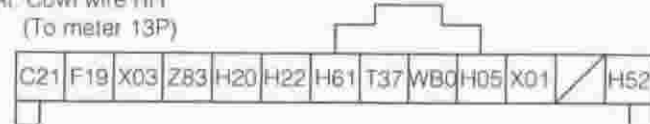

631 : Floor wire No.3
(To cowl wire RH [3Ae])



633 : Floor wire No. 3
(To rear speed sensor LH)



32z : Cowl wire LH
(To meter 13P)

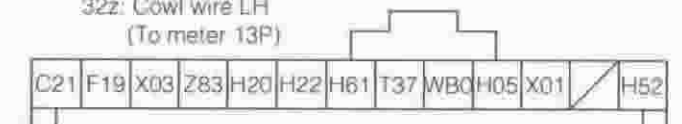

3A8 : Cowl wire RH
(To ABS ECU)

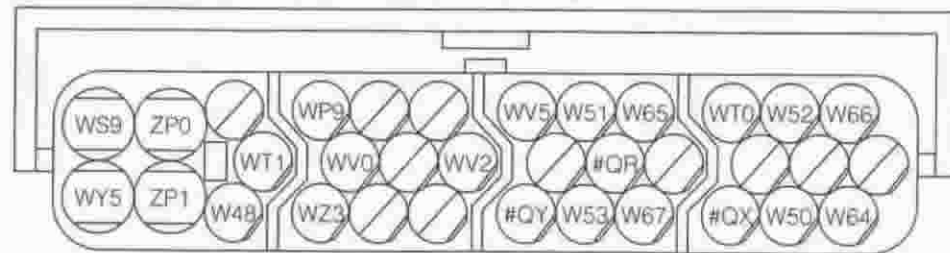

3Vb : Cowl wire RH
(To ABS G sensor)

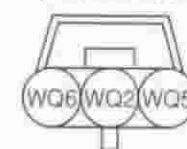

3A3 : Cowl wire RH
(To stop lamp SW)



32h : Cowl wire LH
(To cowl wire RH [31u])

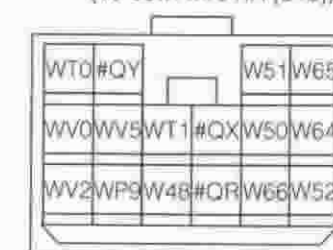

31u : Cowl wire RH
(To cowl wire LH [32h])

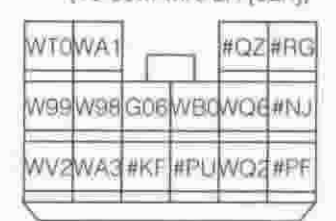

3Aq : Cowl wire RH
(To cowl wire LH [3Mg])

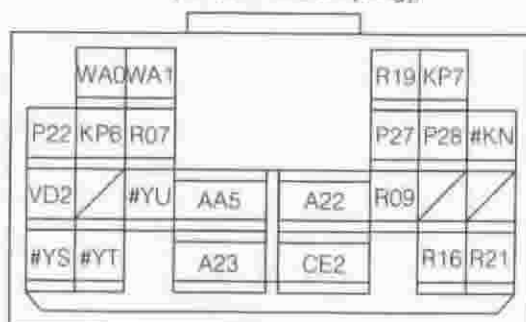

3Mg : Cowl wire LH
(To cowl wire RH [3Aq])

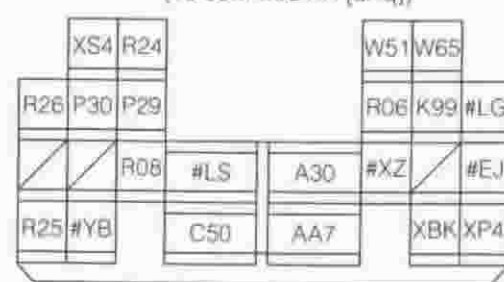

3Aw : Cowl wire RH
(To meter 18P)



32b : Cowl wire LH
(To floor wire No. 3 [634])

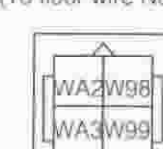

634 : Floor wire No. 3
(To cowl wire LH [32b])



3B1 : Cowl wire LH
(To meter 18P)

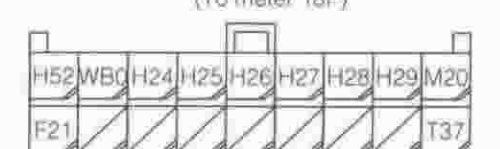

A/T ECU (LHD)

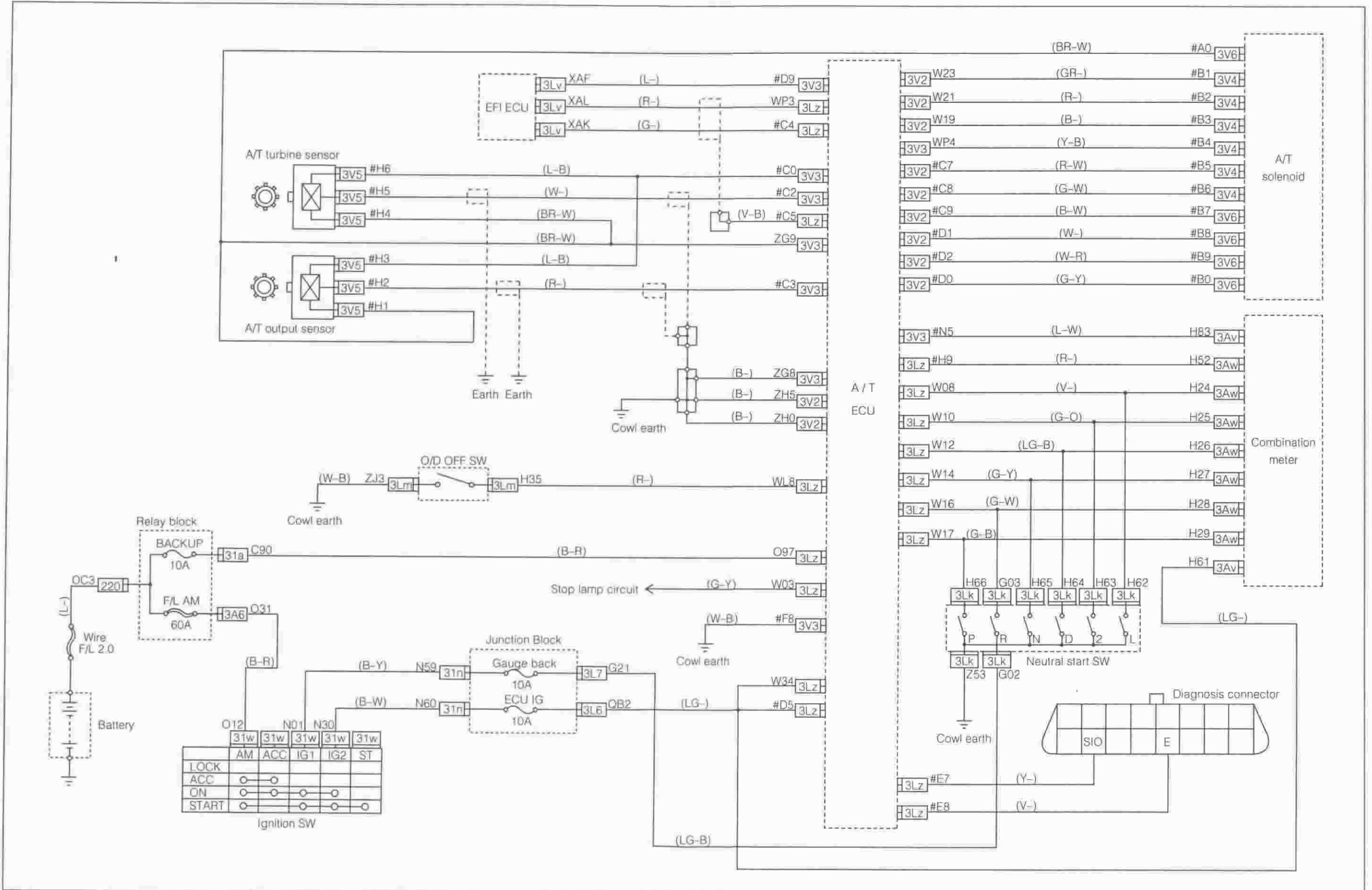

A/T ECU (RHD)

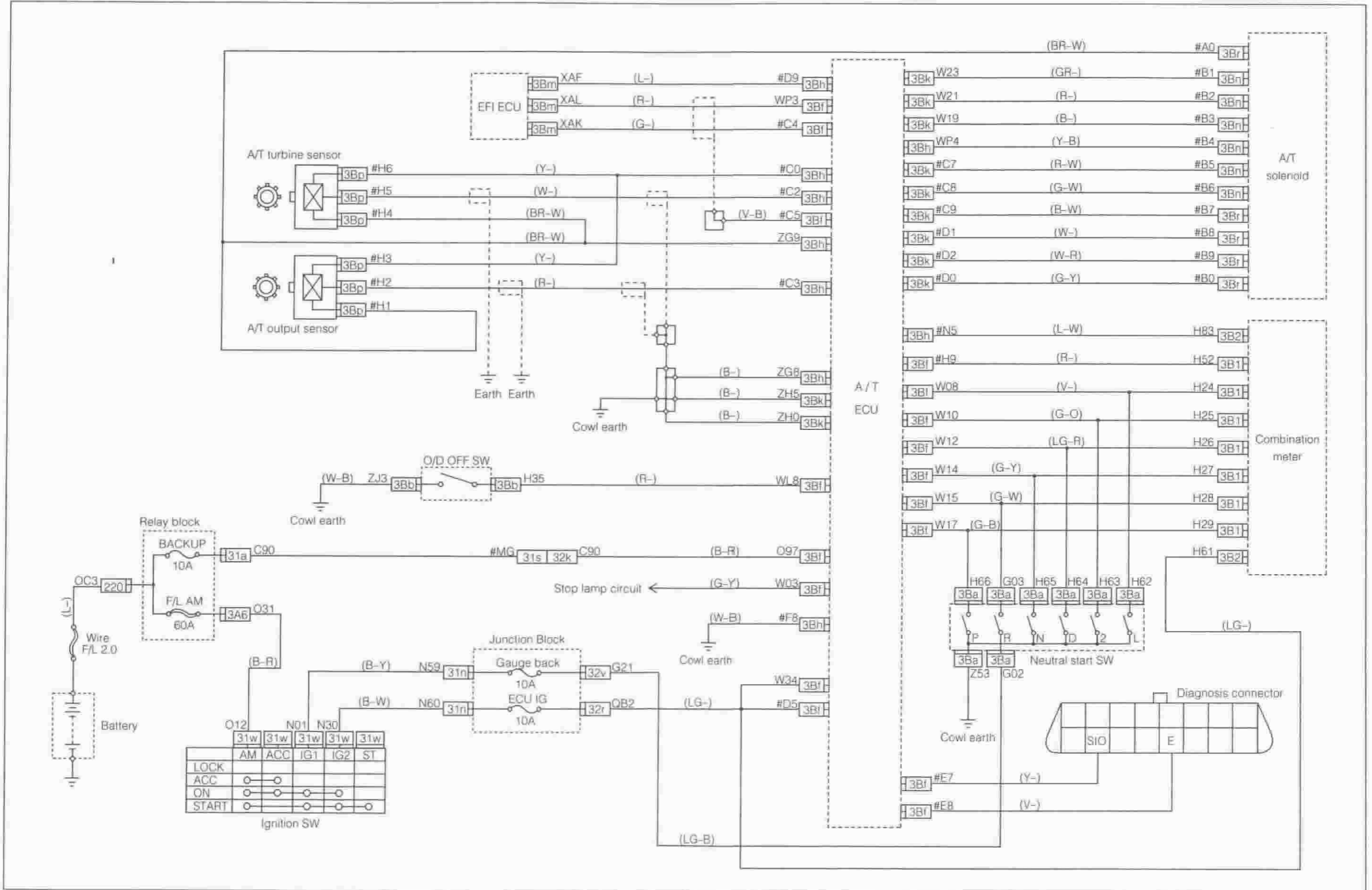

A/T ECU (CONNECTORS)

220 : Engine wire No. 2
(To relay block F)



3V5 : Cowl wire RH
(To A/T turbine/output sensor)

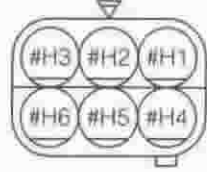

3L7 : Cowl wire RH
(To junction block G)

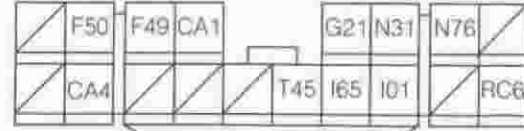

3Bn : Cowl wire LH
(To A/T solenoid A)

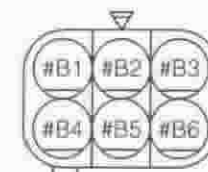

3Br : Cowl wire LH
(To A/T solenoid B)

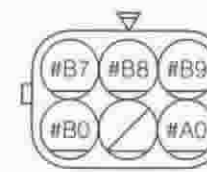

3Bm : Cowl wire LH
(To EFI ECU D)

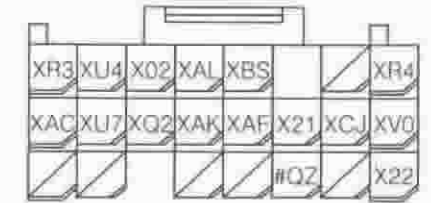

3A6 : Cowl wire RH
(To relay block E)



3V4 : Cowl wire RH
(To A/T solenoid A)

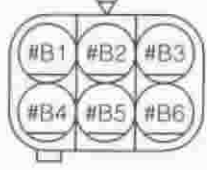

3Lv : Cowl wire RH
(To EFI ECU D)

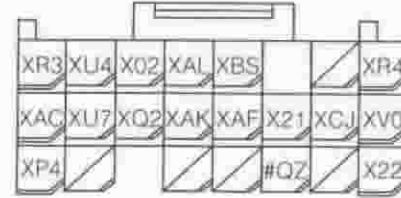

3Bf : Cowl wire LH
(To A/T ECU A)

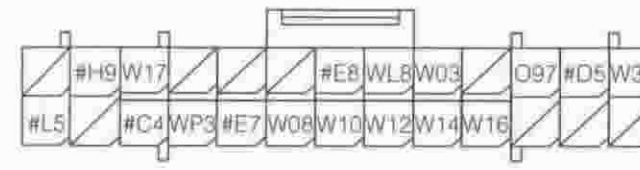

3B1 : Cowl wire LH
(To meter 18P)

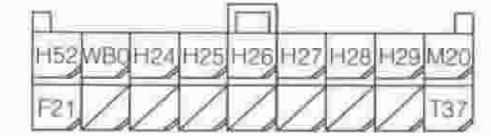

31a : Cowl wire RH
(To relay block A)

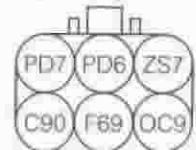

3V6 : Cowl wire RH
(To A/T solenoid B)

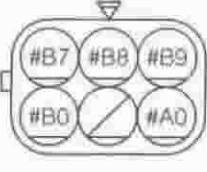

3Aw : Cowl wire RH
(To meter 18P)

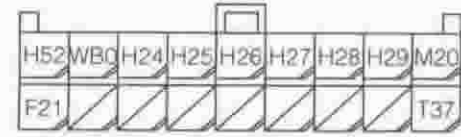

32v : Cowl wire LH
(To junction block G)

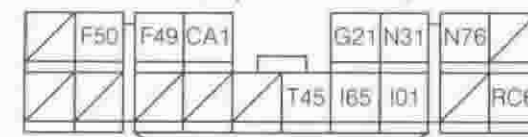

3B2 : Cowl wire LH
(To meter 22P)

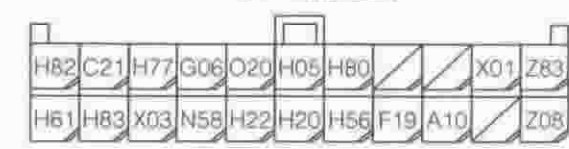

31m : Cowl wire RH
(To junction block A)



3V2 : Cowl wire RH
(To A/T ECU C)

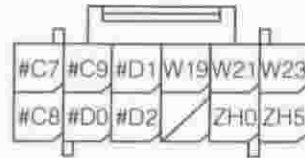

3Av : Cowl wire RH
(To meter 22P)

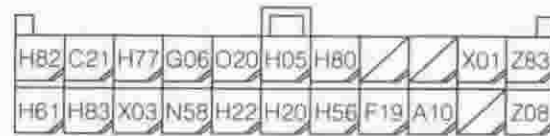

3Bh : Cowl wire LH
(To A/T ECU B)

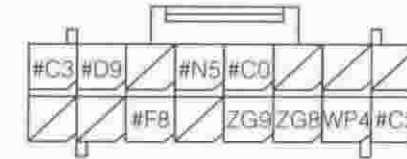

3Lz : Cowl wire RH
(To A/T ECU A)

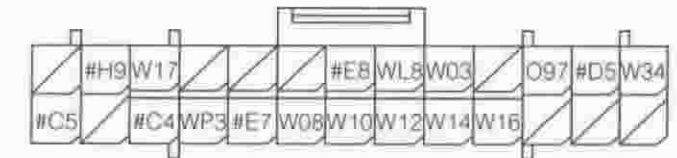

31n : Cowl wire RH
(To junction block B)



3V3 : Cowl wire RH
(To A/T ECU B)

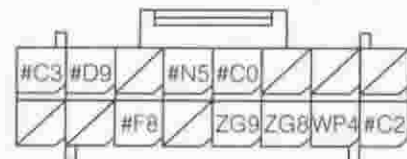

3Ba : Cowl wire LH
(To neutral start SW)

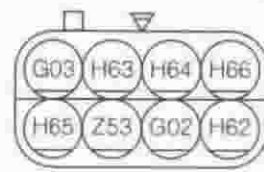

3Bp : Cowl wire LH
(To A/T turbine/output sensor)

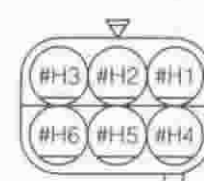

3Bk : Cowl wire LH
(To A/T ECU C)

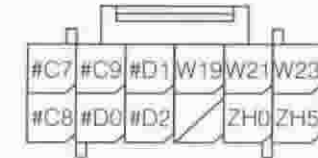

31w : Cowl wire RH
(To ignition SW)

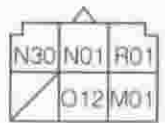

32k : Cowl wire LH
(To cowl wire RH [31s])

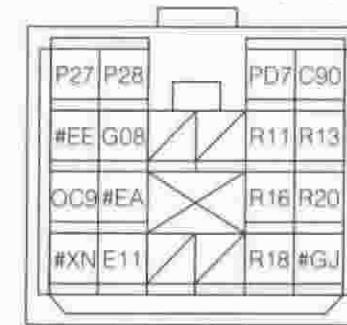

31s : Cowl wire RH
(To cowl wire LH [32k])

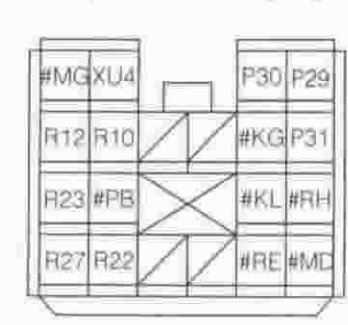

3Lk : Cowl wire RH
(To neutral start SW)

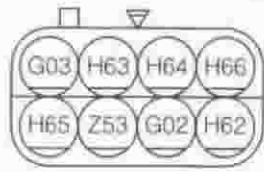

3L6 : Cowl wire RH
(To junction block F)

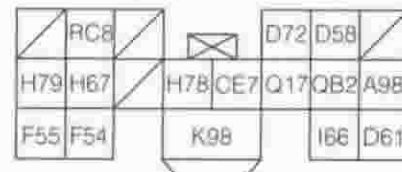

3Bb : Cowl wire LH
(To O/D off SW)

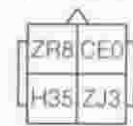

3Lm : Cowl wire RH
(To O/D SW)



32r : Cowl wire LH
(To junction block F)



DIFFERENTIAL LOCK SYSTEM

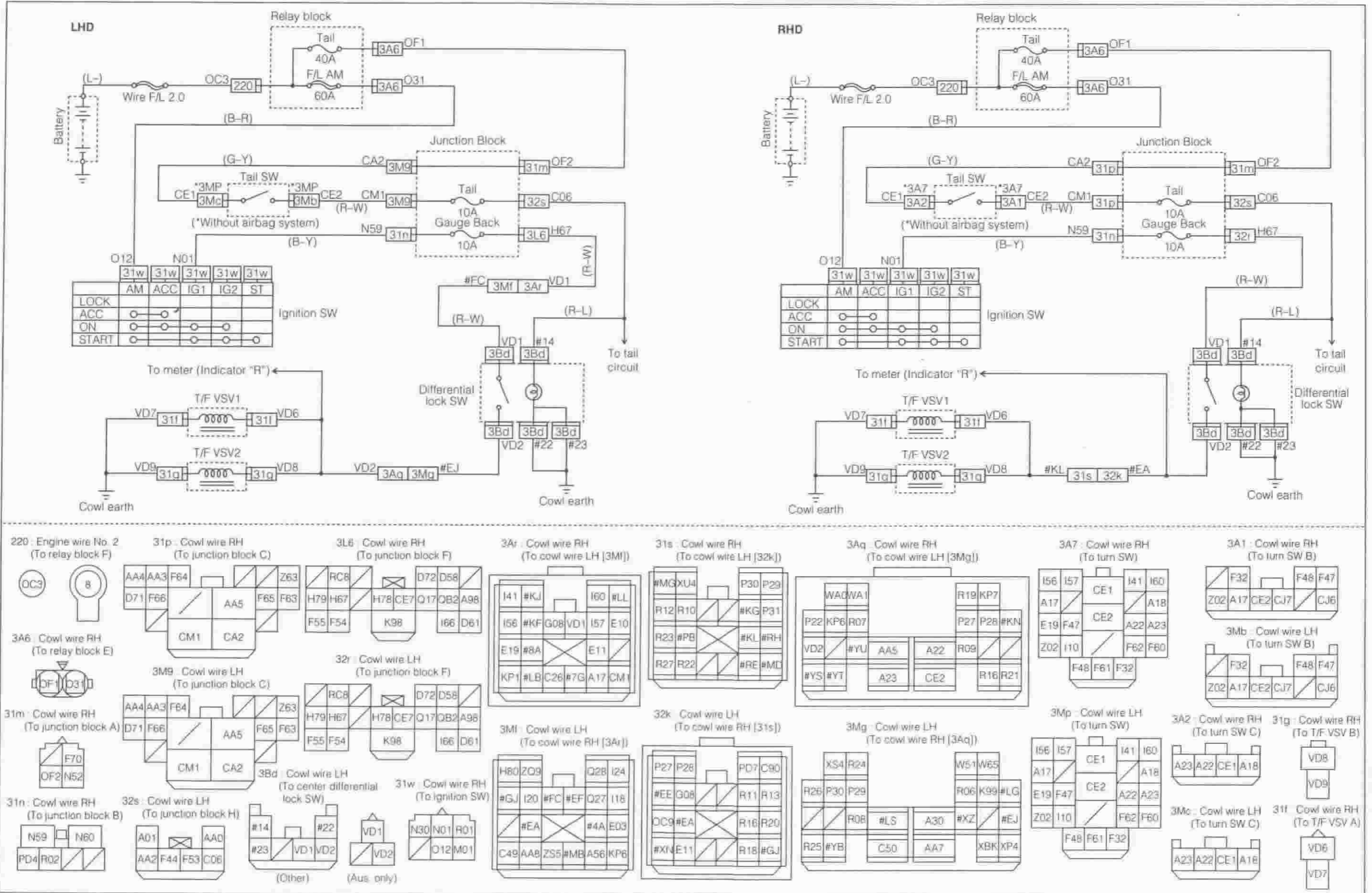

HEADLAMP (LHD)

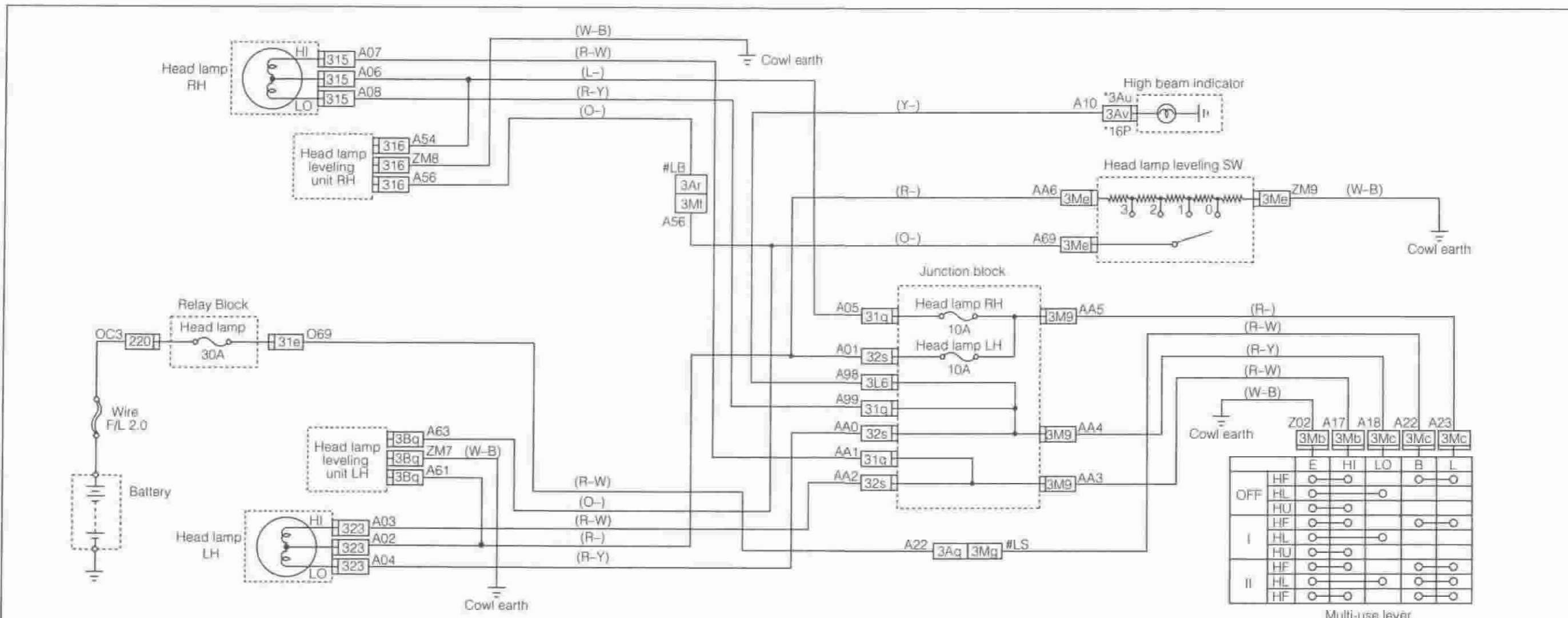

		E	HI	LO	B	L
OFF	HF	○	○		○	○
	HL	○		○		
	HU	○	○			
I	HF	○	○		○	○
	HL	○		○		
	HU	○	○			
II	HF	○	○		○	○
	HL	○		○		
	HF	○	○		○	○

Multi-use lever

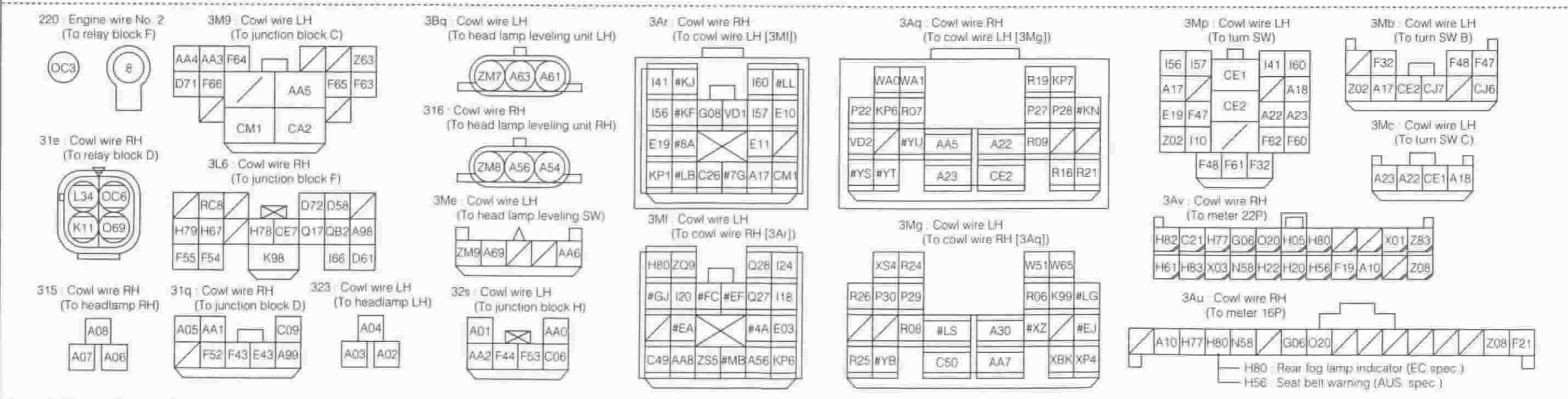

H80 - Rear fog lamp indicator (EC spec.)
 H56 - Seat belt warning (AUS. spec.)

HEADLAMP (RHD)

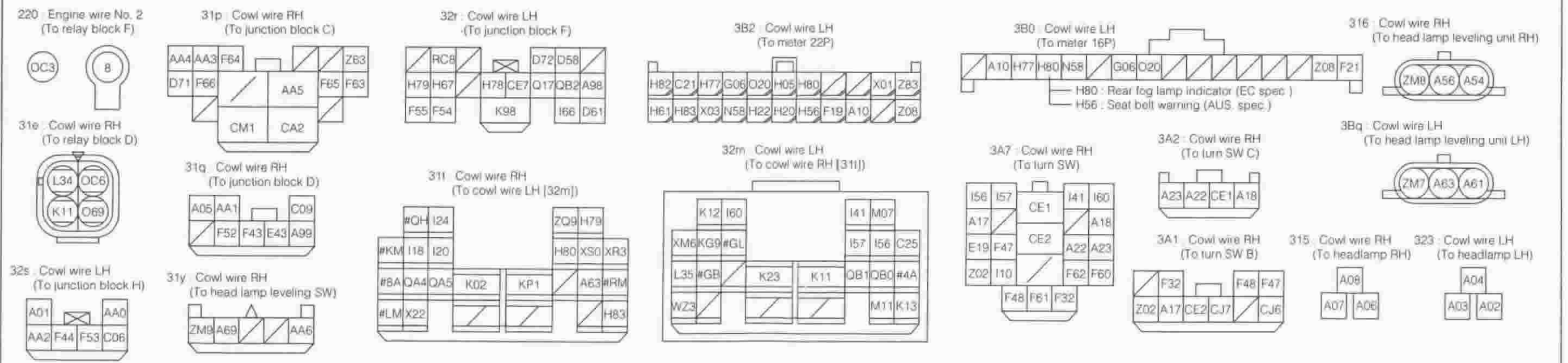
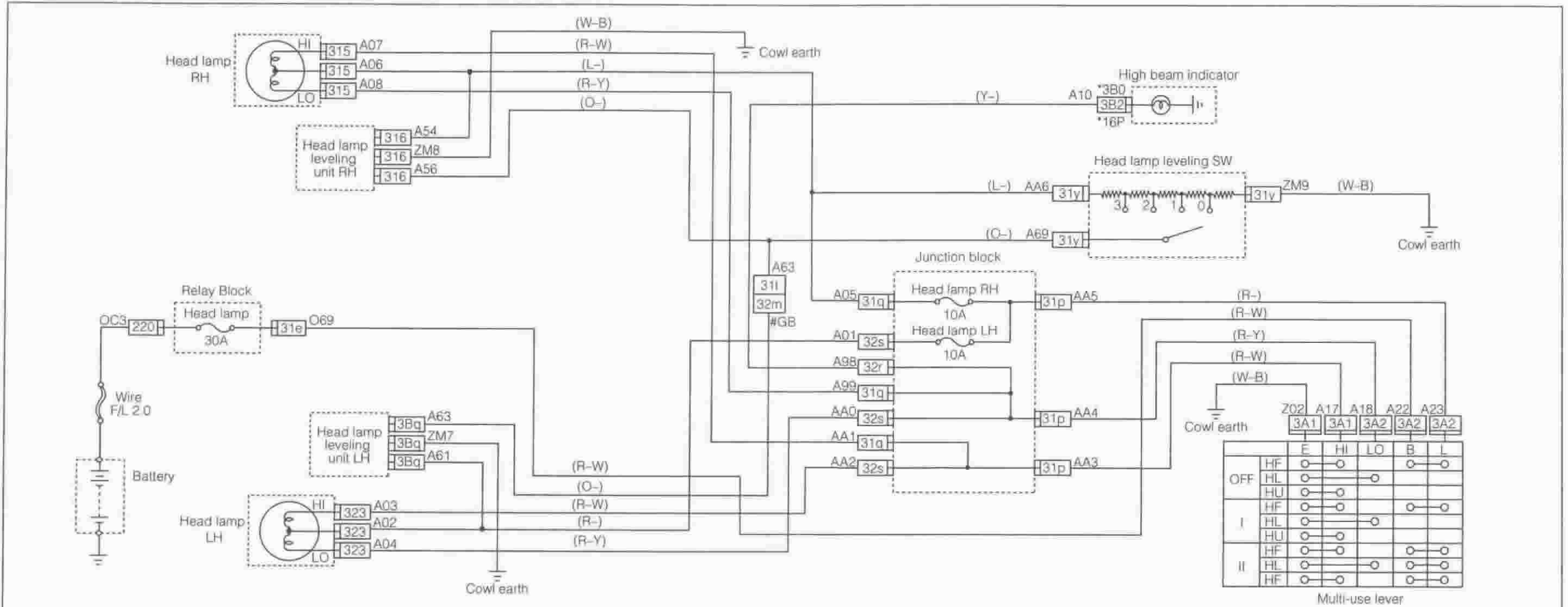

REAR FOG LAMP (LHD)

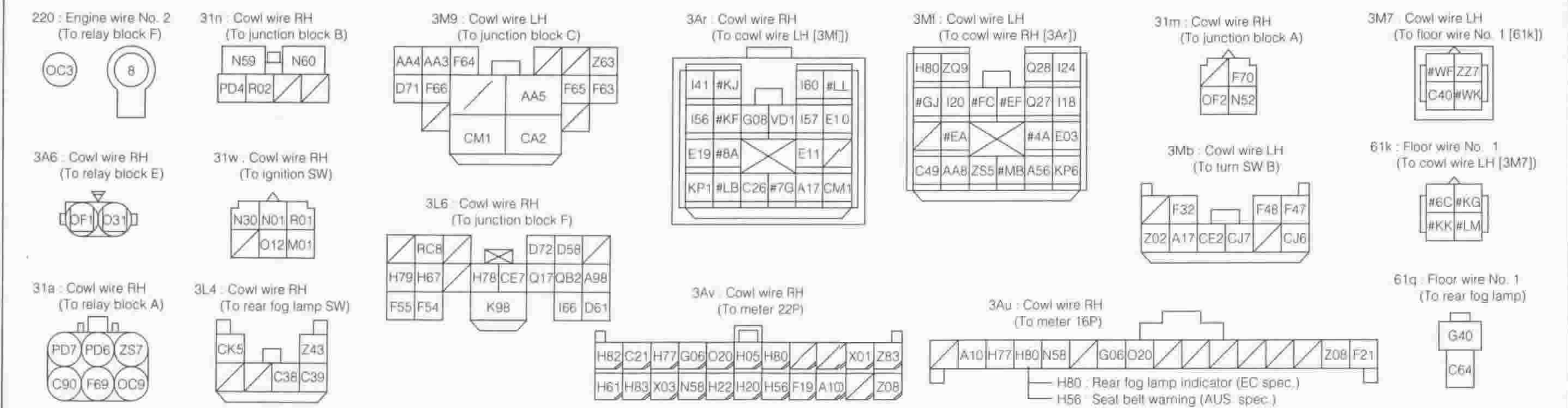
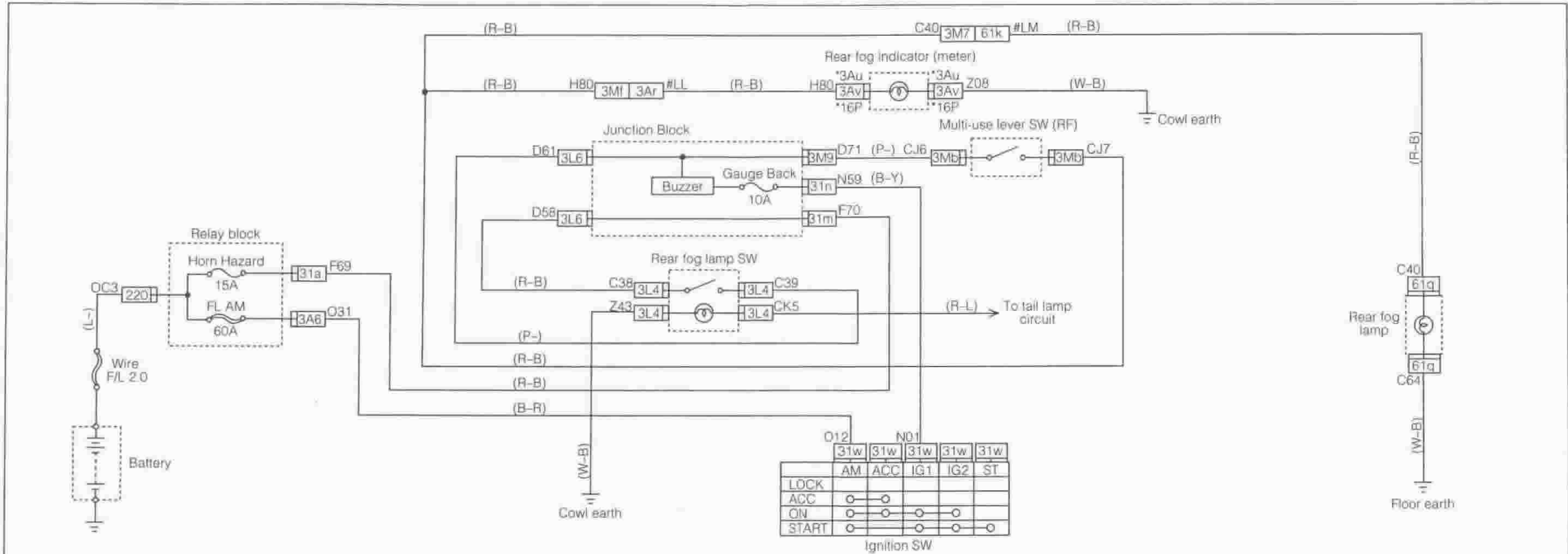

REAR FOG LAMP (RHD)

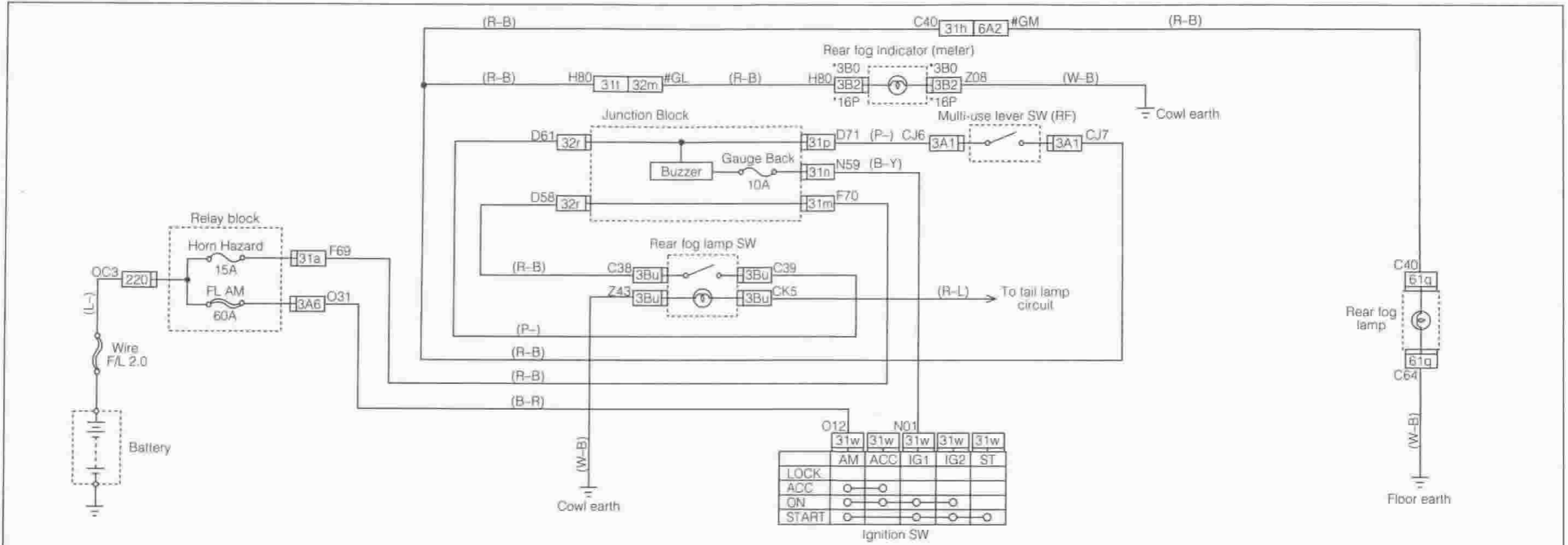

Ignition SW

	31w	31w	31w	31w	31w
LOCK	AM	ACC	IG1	IG2	ST
ACC	○	○			
ON	○	○	○	○	
START	○	○	○	○	○

220 : Engine wire No. 2 (To relay block F)



31n : Cowl wire RH (To junction block B)

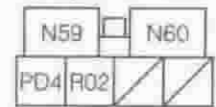

3A6 : Cowl wire RH (To relay block E)



31w : Cowl wire RH (To ignition SW)



31a : Cowl wire RH (To relay block A)

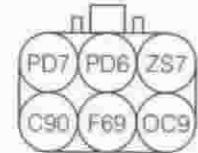

3Bu : Cowl wire LH (To rear fog lamp SW)

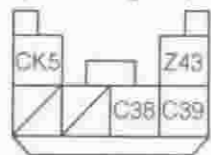

31m : Cowl wire RH (To junction block A)



31p : Cowl wire RH (To junction block C)

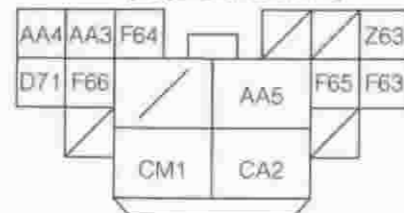

31t : Cowl wire RH (To cowl wire LH [32m])

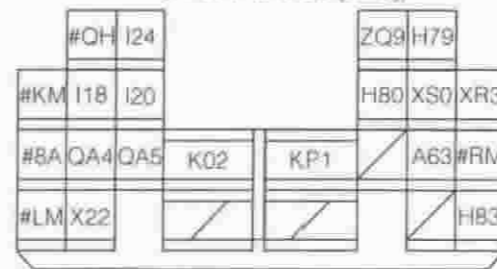

32r : Cowl wire LH (To junction block F)

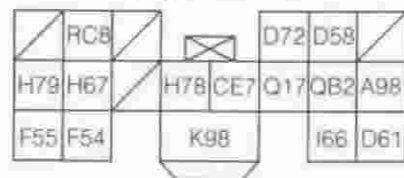

3B2 : Cowl wire LH (To meter 22P)

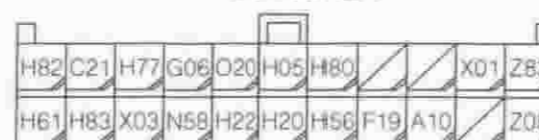

6A2 : Floor wire No. 1 (To cowl wire RH [31h])

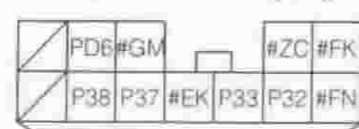

31h : Cowl wire RH (To floor wire No. 1 [6A2])

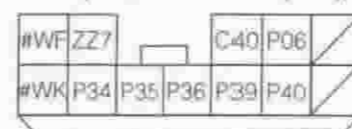

32m : Cowl wire LH (To cowl wire RH [31t])

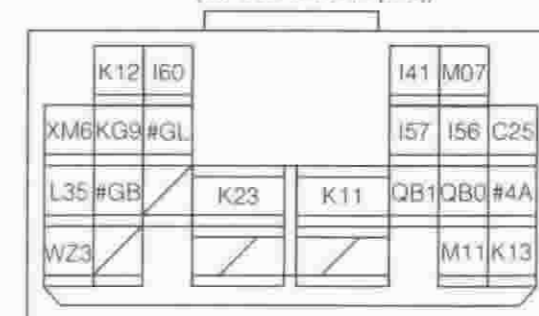

3A1 : Cowl wire RH (To turn SW B)



61q : Floor wire No. 1 (To rear fog lamp)

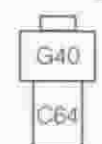

3B0 : Cowl wire LH (To meter 16P)

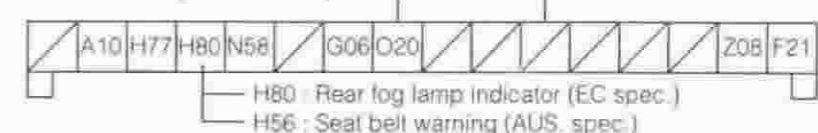

H80 : Rear fog lamp indicator (EC spec.)
H56 : Seat belt warning (AUS. spec.)

STOP LAMP (LHD)

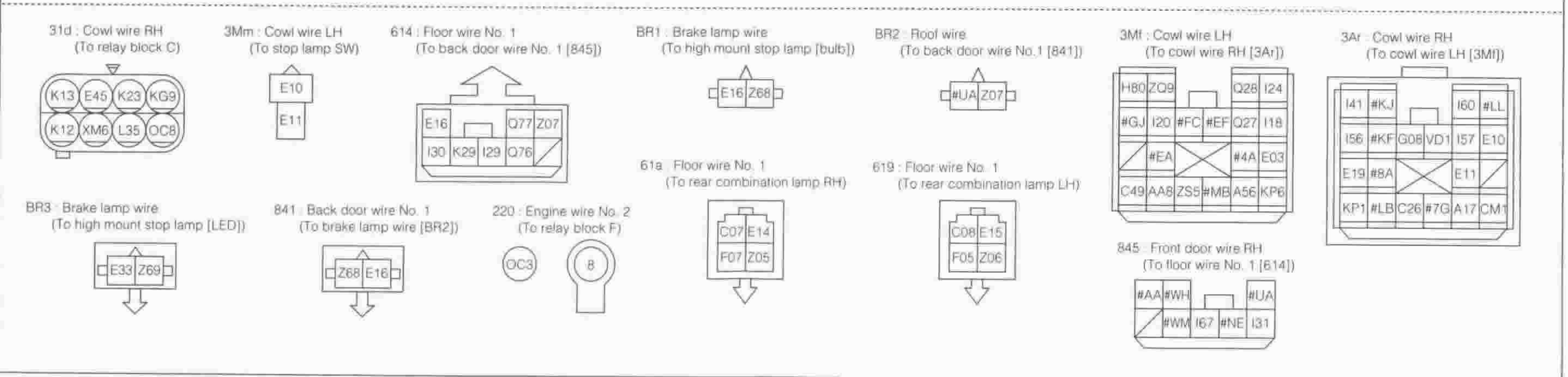
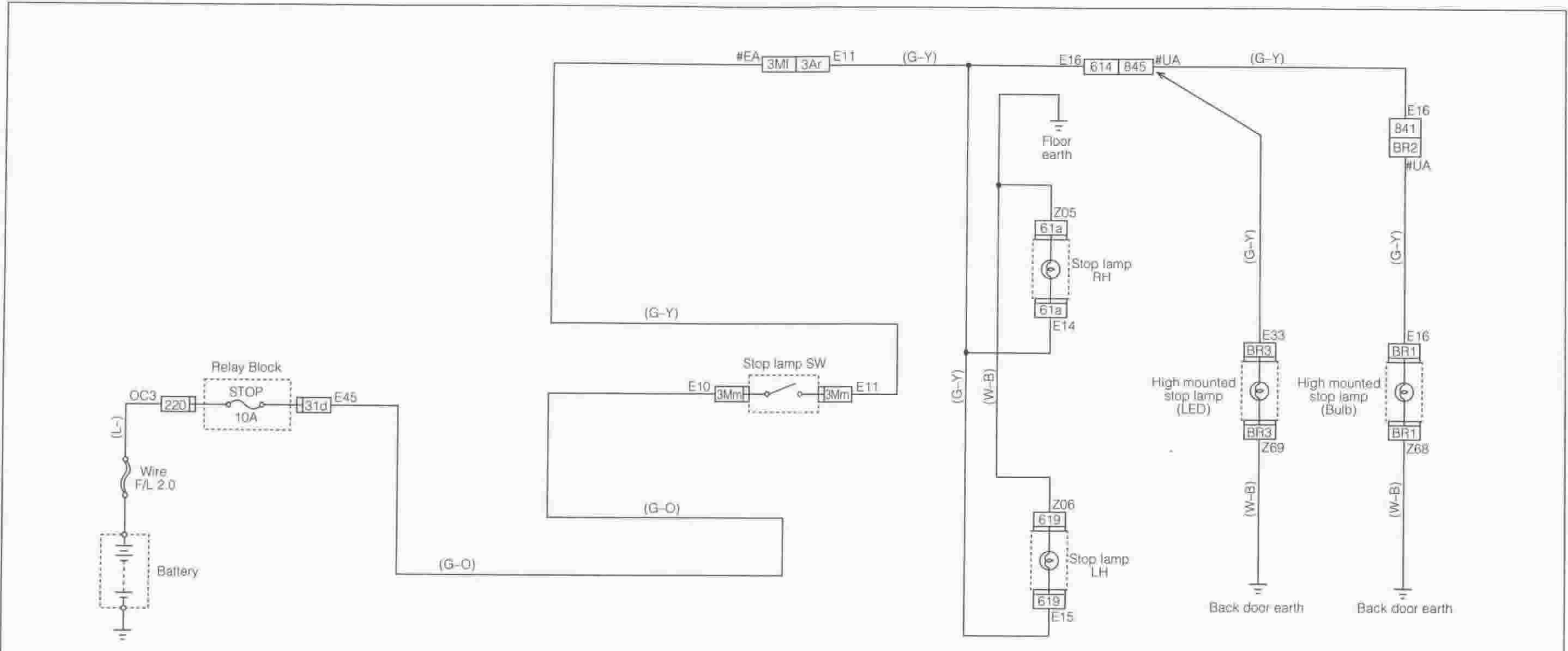

STOP LAMP (RHD)

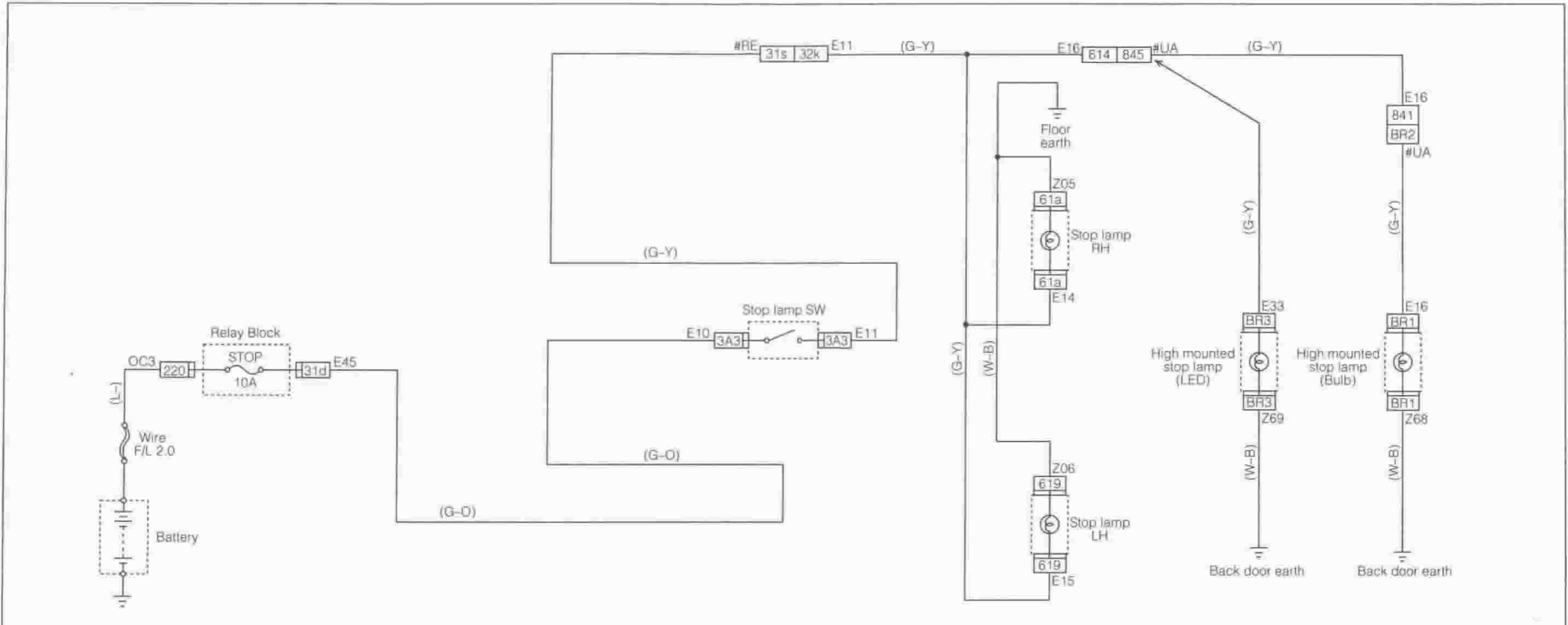

31d : Cowl wire RH
(To relay block C)

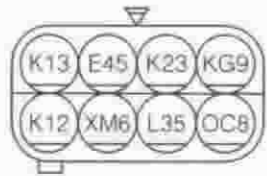

32k : Cowl wire LH
(To cowl wire RH [31s])

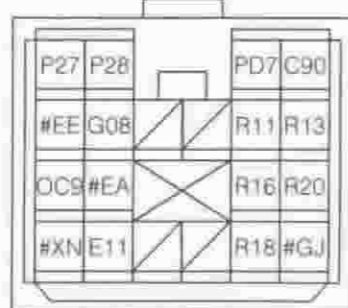

3A3 : Cowl wire RH
(To stop lamp SW)



845 : Front door wire RH
(To floor wire No. 1 [614])

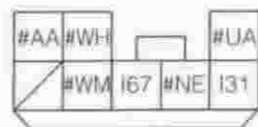

31s : Cowl wire RH
(To cowl wire LH [32k])

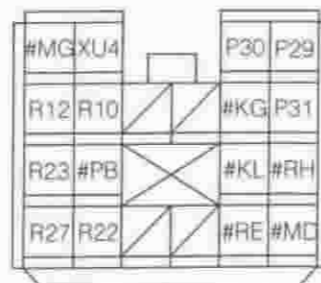

841 : Back door wire No. 1
(To brake lamp wire [BR2])

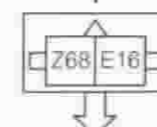

614 : Floor wire No. 1
(To back door wire No. 1 [841])

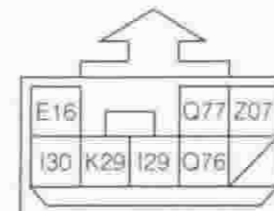

BR1 : Brake lamp wire
(To high mount stop lamp [bulb])



BR2 : Roof wire
(To back door wire No. 1 [841])



BR3 : Brake lamp wire
(To high mount stop lamp [LED])

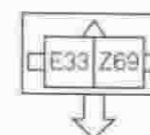

220 : Engine wire No. 2
(To relay block F)

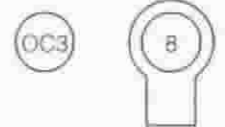

619 : Floor wire No. 1
(To rear combination lamp LH)

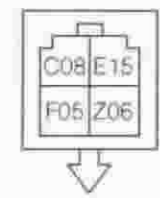

BACK UP LAMP (LHD)

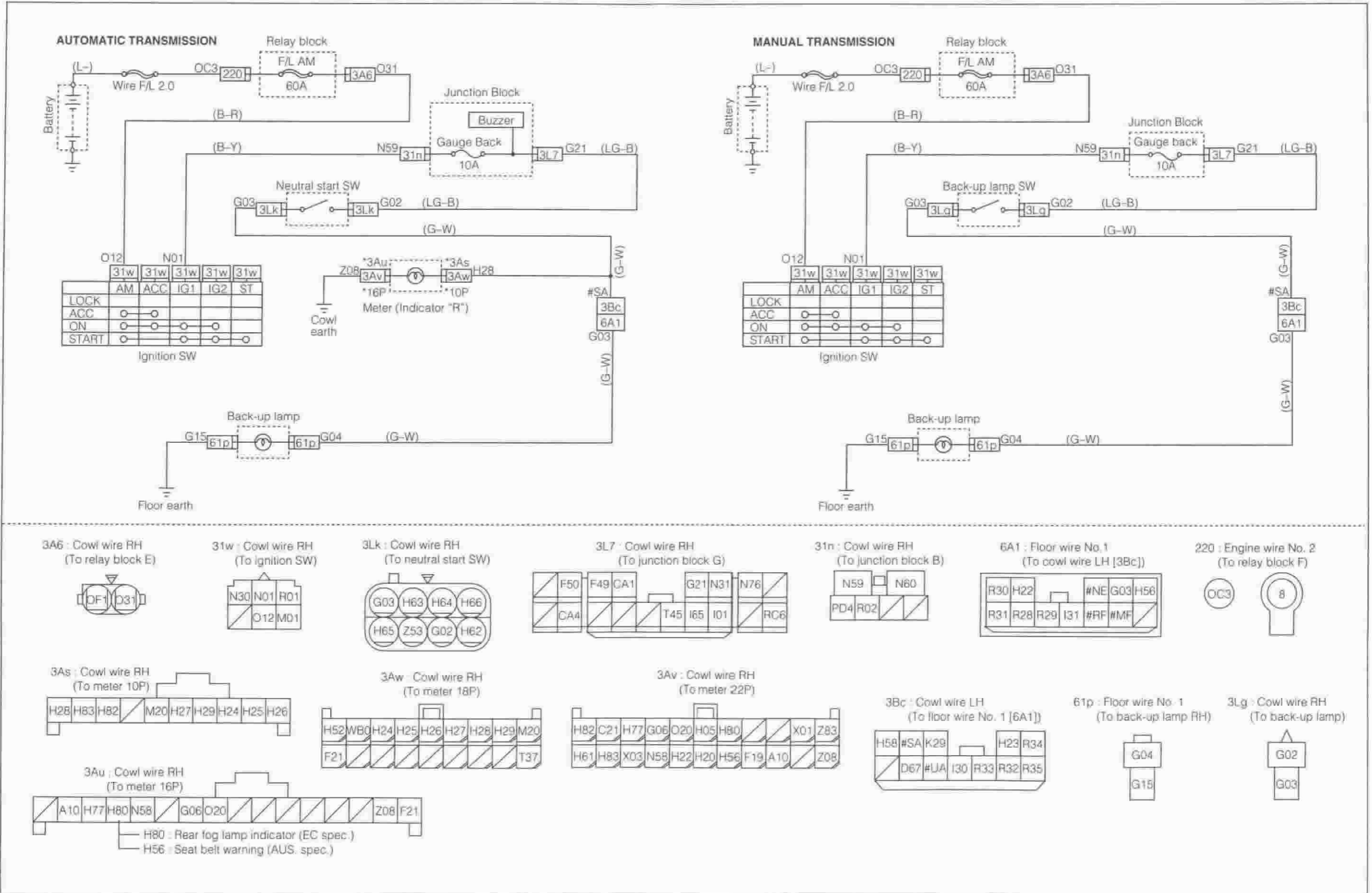

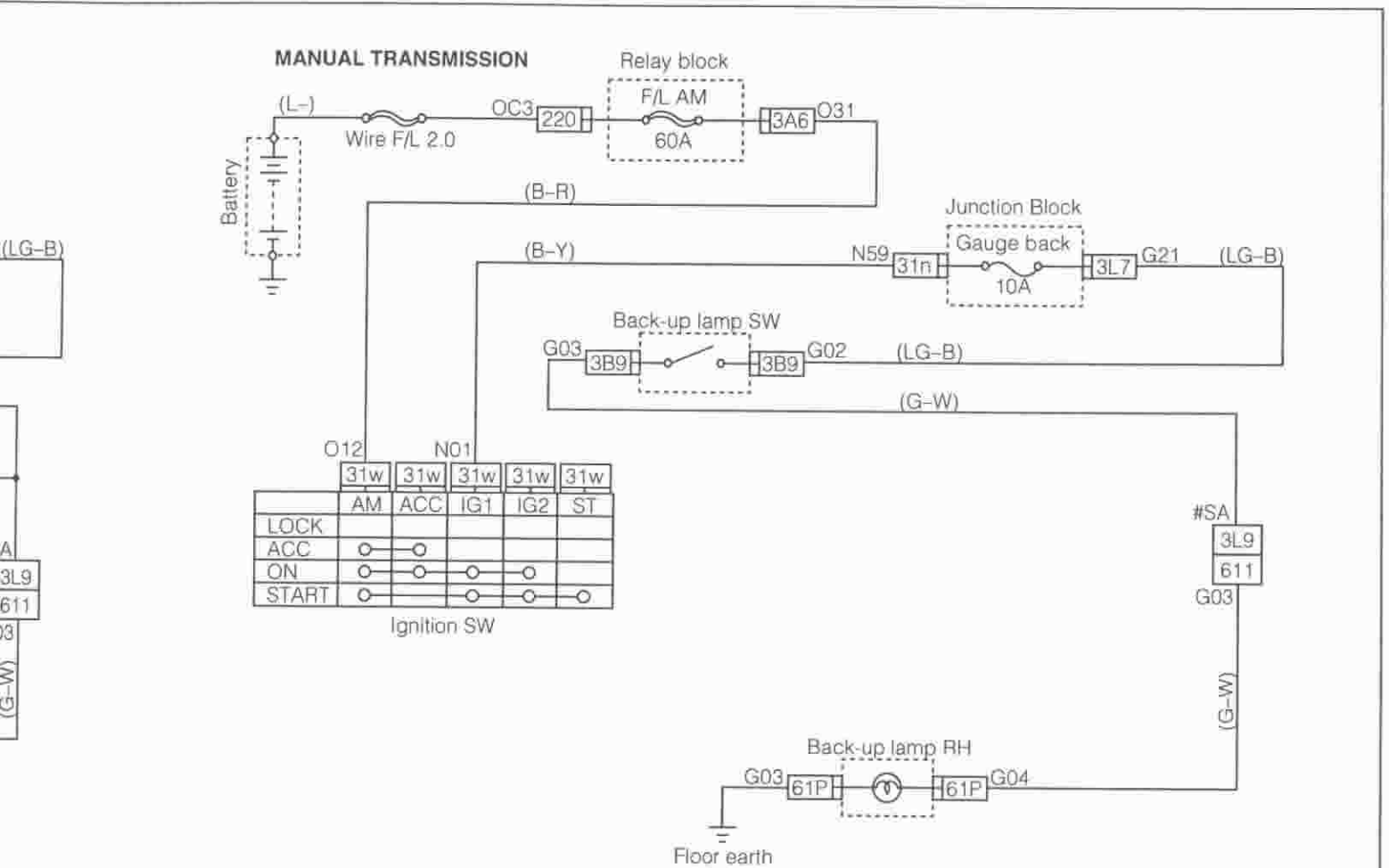

61p: Floor wire No. 1
(To back-up lamp RH)

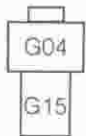

611: Floor wire No. 1
(To cowl wire RH [3L9])

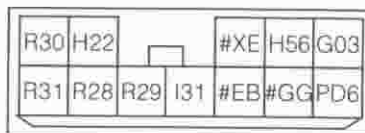

32v: Cowl wire LH
(To junction block G)

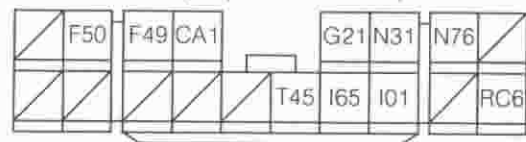

3B9: Cowl wire LH
(To back-up lamp)



3B2: Cowl wire LH
(To meter 22P)



220: Engine wire No. 2
(To relay block F)

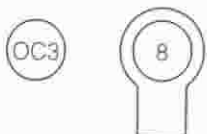

3L9: Cowl wire RH
(To floor wire No. 1 [611])

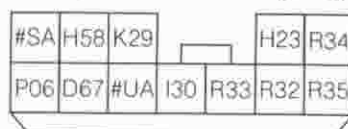

3B1: Cowl wire LH
(To meter 18P)



INTERIOR LAMP

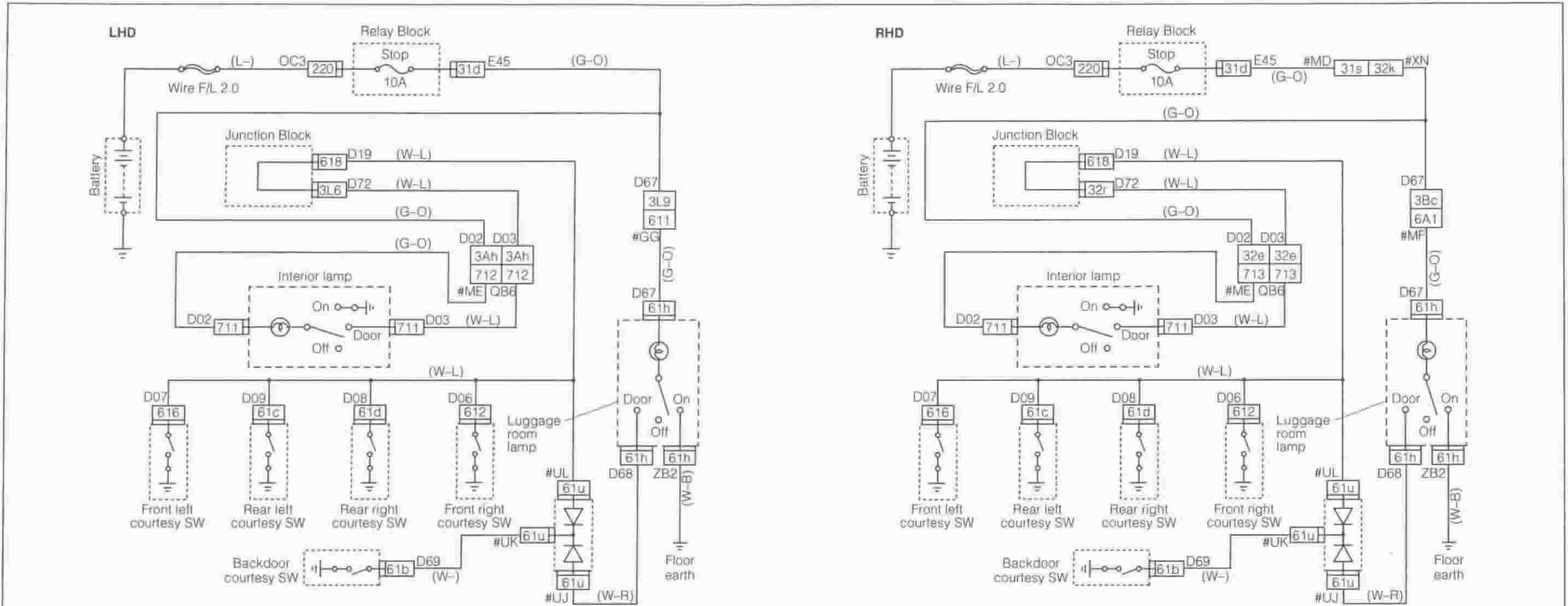

220 : Engine wire No. 2
(To relay block F)

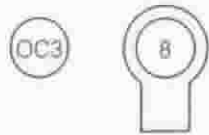

31d : Cowl wire RH
(To relay block C)

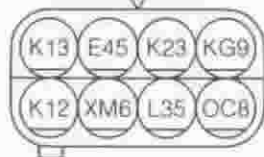

6A1 : Floor wire No. 1
(To cowl wire LH [3Bc])

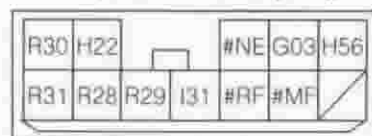

3L9 : Cowl wire RH
(To floor wire No. 1 [611])

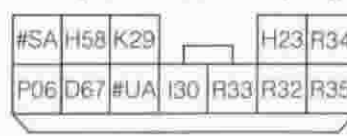

3Bc : Cowl wire LH
(To floor wire No. 1 [6A1])

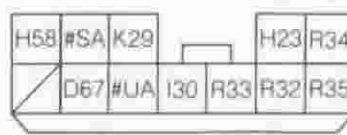

611 : Floor wire No. 1
(To cowl wire RH [3L9])



3L6 : Cowl wire RH
(To junction block F)



32r : Cowl wire LH
(To junction block F)



618 : Floor wire No. 1
(To junction block I)

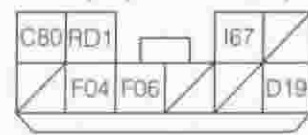

3Ah : Cowl wire RH
(To roof wire [712])

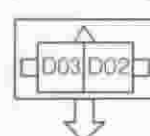

32e : Cowl wire LH
(To roof wire [713])

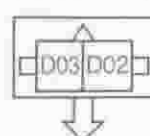

712 : Roof wire
(To cowl wire RH [3Ah])



616 : Floor wire No. 1
(To front door-courtesy SW LH)



612 : Floor wire No. 1
(To front door courtesy SW RH)



61h : Floor wire No. 1
(To luggage room lamp)

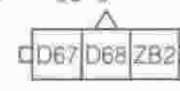

61c : Floor wire No. 1
(To rear door-courtesy SW LH)



61d : Floor wire No. 1
(To rear door-courtesy SW RH)



61b : Floor wire No. 1
(To back door courtesy SW)



713 : Roof wire
(To cowl wire LH [32e])



61u : Floor wire No. 1
(To diode)

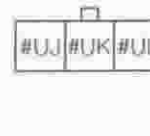

711 : Roof wire
(To interior lamp)



TAIL LAMP & LICENSE PLATE LAMP (LHD)

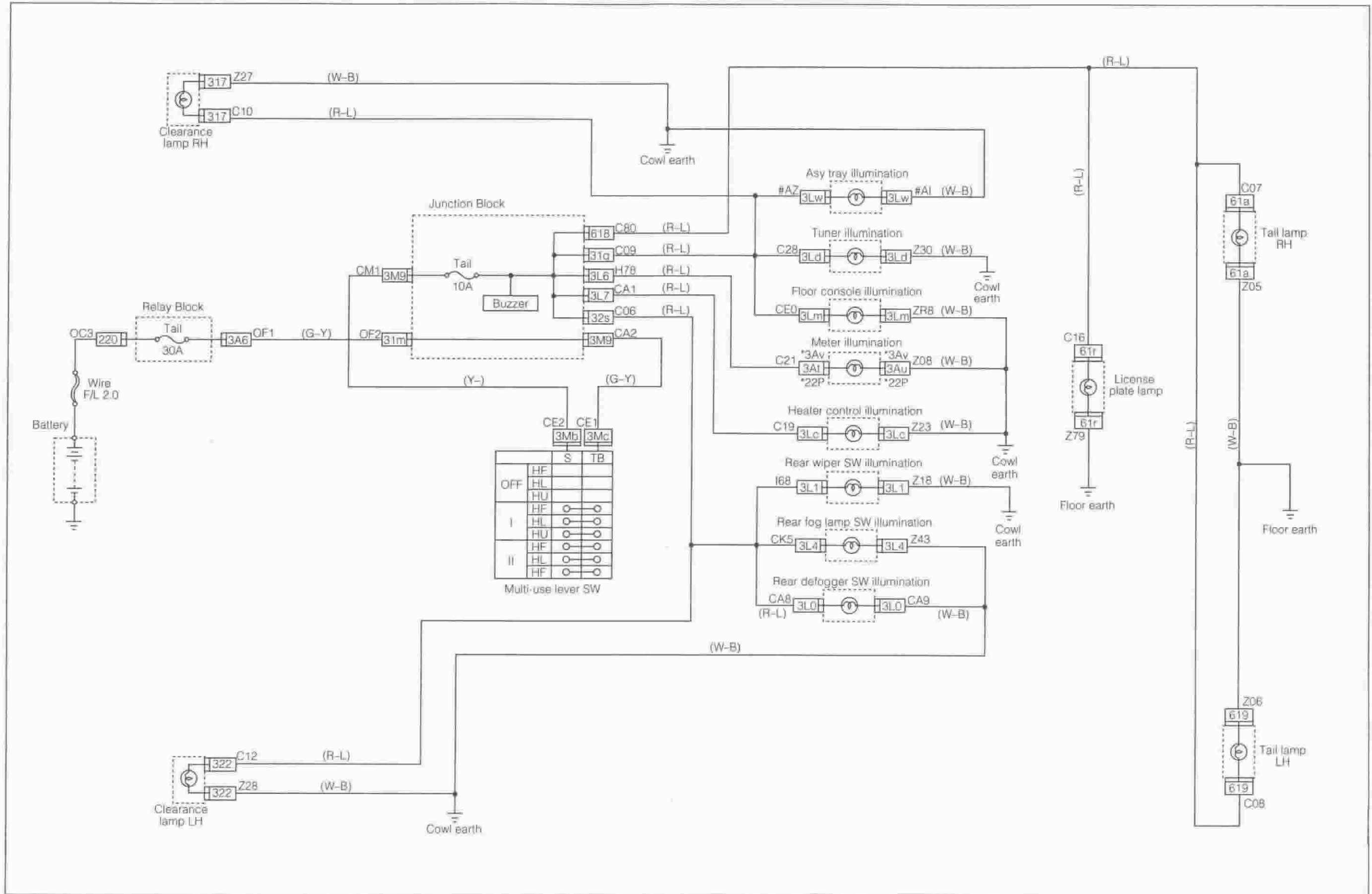

TAIL LAMP & LICENSE PLATE LAMP (RHD)

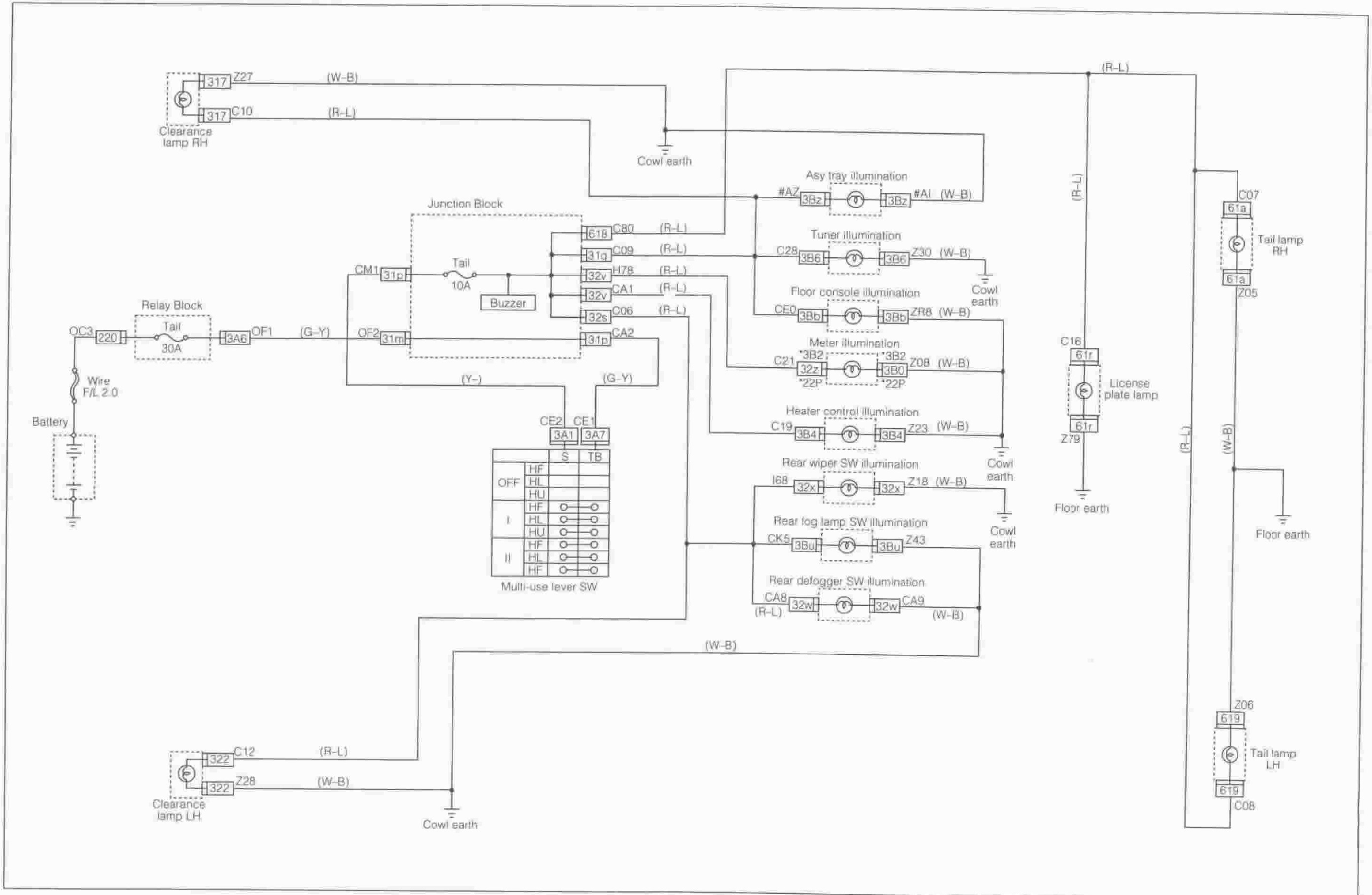

TAIL LAMP & LICENSE PLATE LAMP (CONNECTORS)

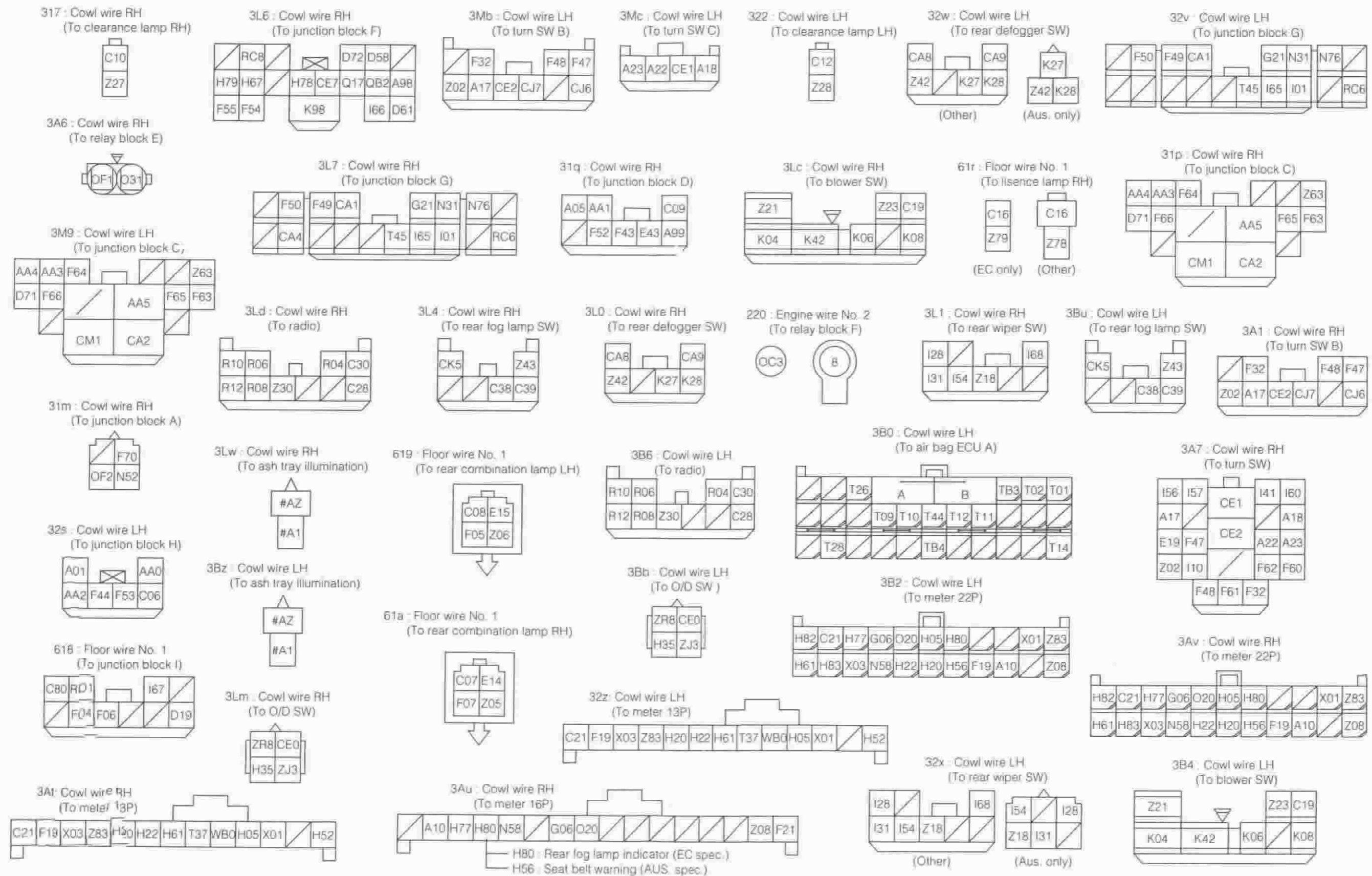

HAZARD WARNING & TURN SIGNAL LAMP (LHD)

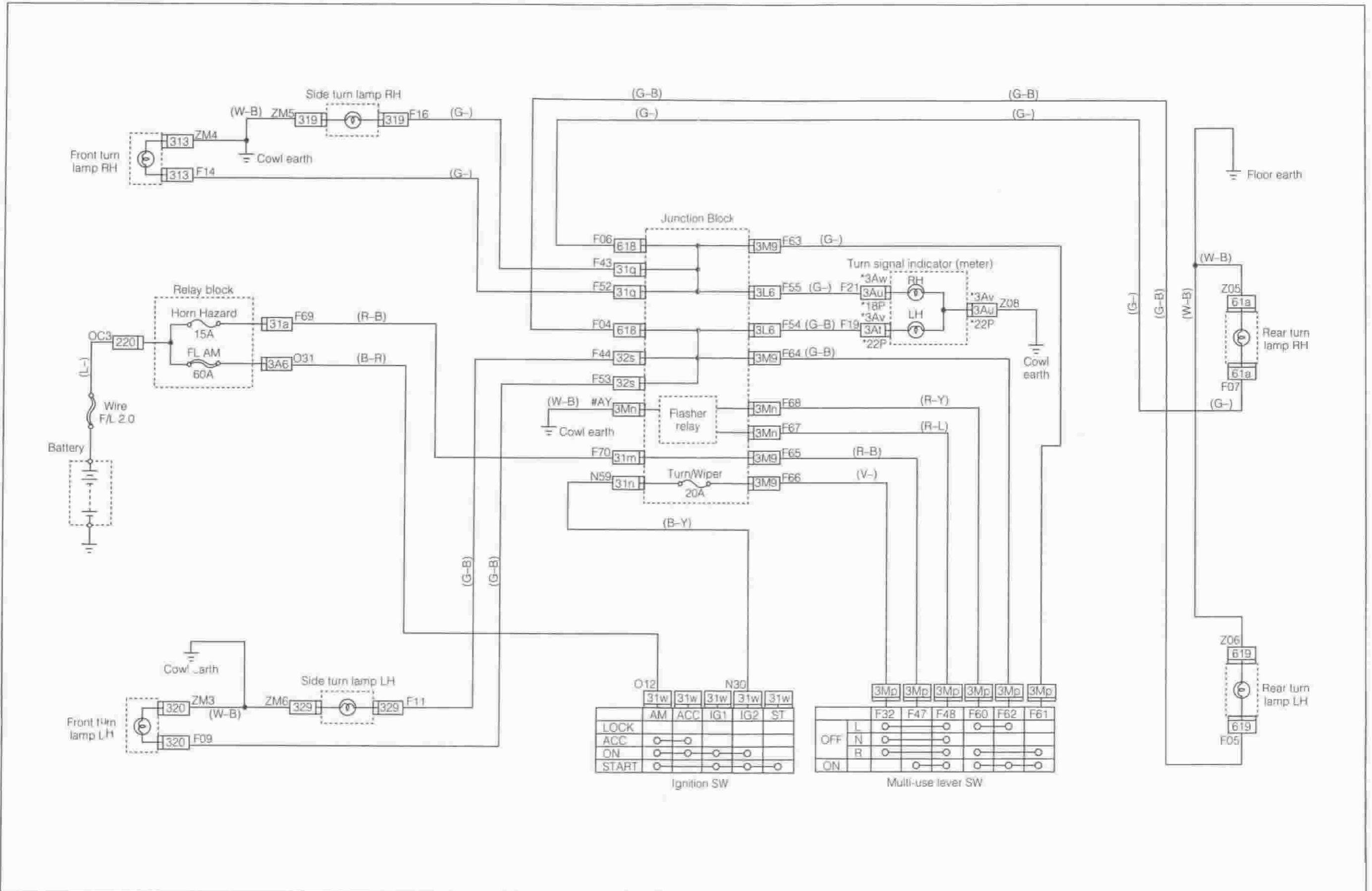

HAZARD WARNING & TURN SIGNAL LAMP (RHD)

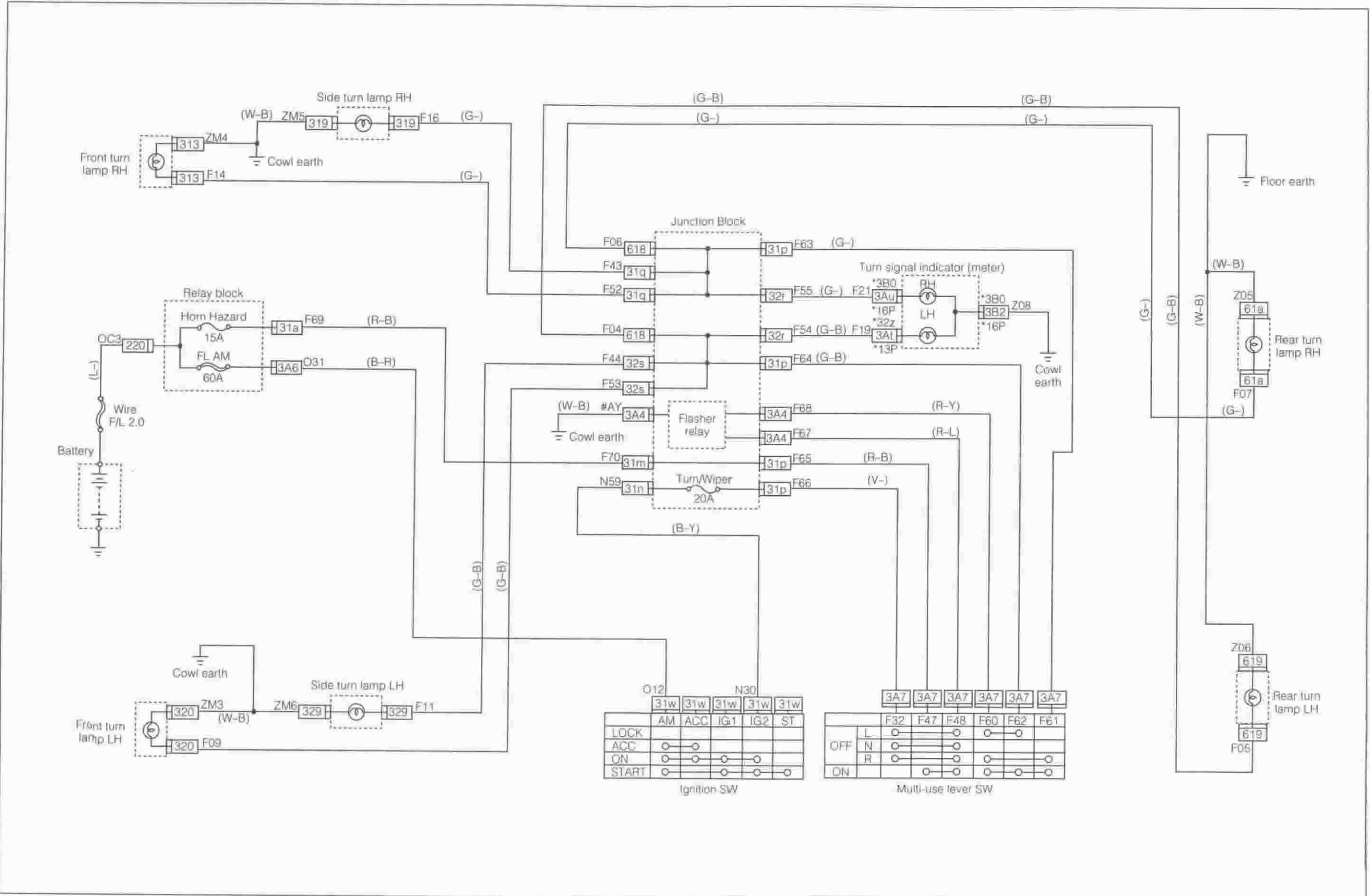

HAZARD WARNING & TURN SIGNAL LAMP (CONNECTORS)

313 : Cowl wire RH
(To front turn lamp RH)

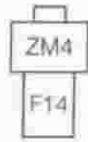

31q : Cowl wire RH
(To junction block D)

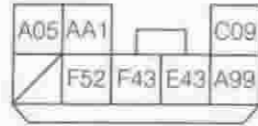

619 : Floor wire No. 1
(To rear combination lamp LH)

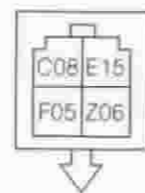

32r : Cowl wire LH
(To junction block F)

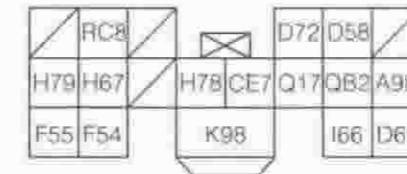

3Aw : Cowl wire RH
(To meter 18P)

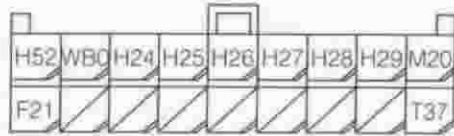

31a : Cowl wire RH
(To relay block A)

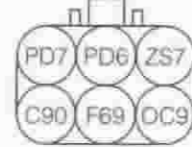

61a : Floor wire No. 1
(To rear combination lamp RH)

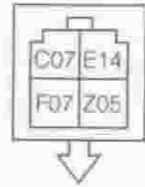

3Au : Cowl wire RH
(To meter 18P)



319 : Cowl wire RH
(To side turn lamp RH)



32s : Cowl wire LH
(To junction block H)



3M9 : Cowl wire LH
(To junction block C)

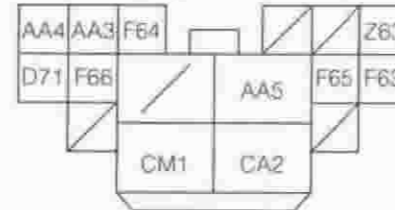

3B0 : Cowl wire LH
(To meter 18P)

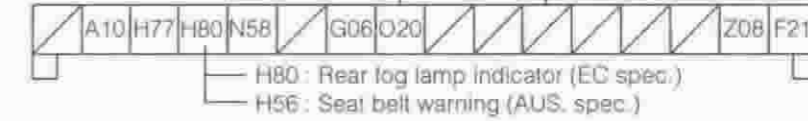

320 : Cowl wire LH
(To front turn lamp LH)



3Mn : Cowl wire LH
(To flasher relay)



3Mp : Cowl wire LH
(To turn SW)

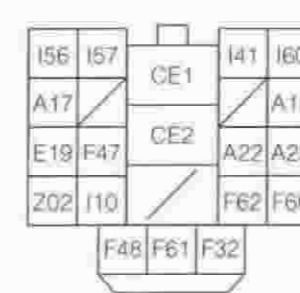

220 : Engine wire No. 2
(To relay block F)

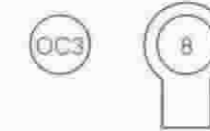

31p : Cowl wire RH
(To junction block C)

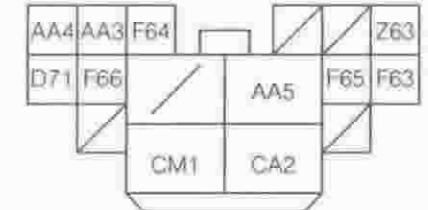

329 : Cowl wire LH
(To side turn lamp LH)



31m : Cowl wire RH
(To junction block A)



3A4 : Cowl wire RH
(To flasher relay)



31w : Cowl wire RH
(To ignition SW)



3Mb : Cowl wire LH
(To turn SW B)

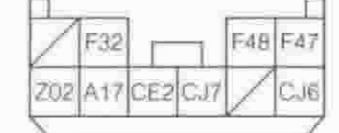

3A6 : Cowl wire RH
(To relay block E)



31n : Cowl wire RH
(To junction block B)



3Av : Cowl wire RH
(To meter 22P)



3A4 : Cowl wire RH
(To flasher relay)



3A7 : Cowl wire RH
(To turn SW)

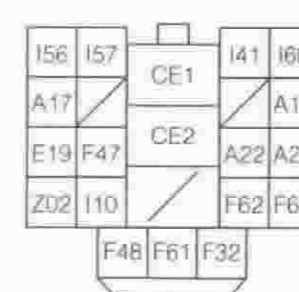

61g : Floor wire No. 1
(To junction block I)



3A1 : Cowl wire RH
(To turn SW B)

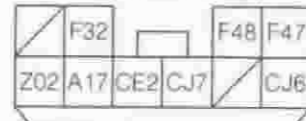

3B2 : Cowl wire LH
(To meter 22P)



DAYLIGHT

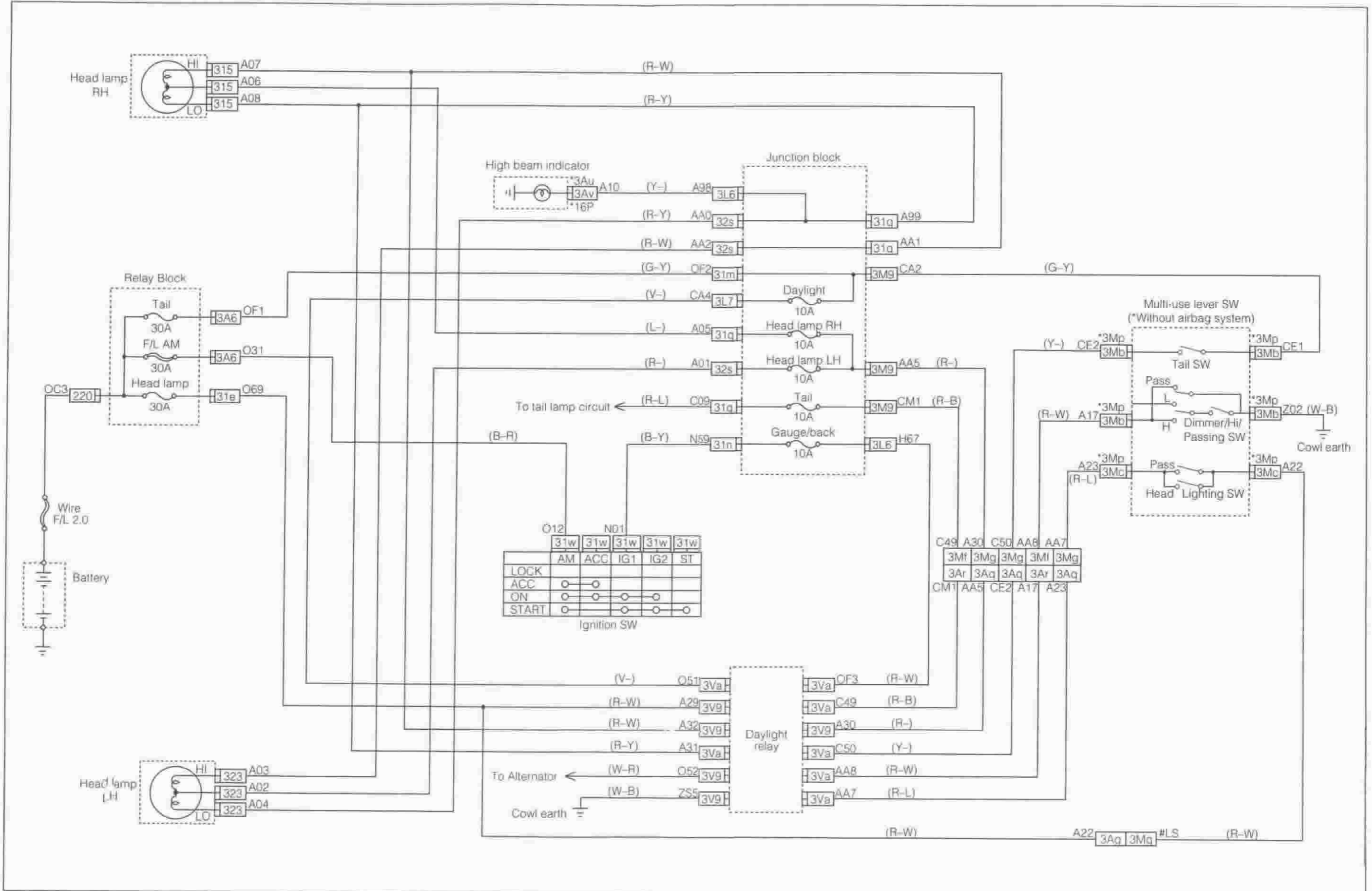

DAYLIGHT (CONNECTORS)

220 : Engine wire No. 2
(To relay block F)

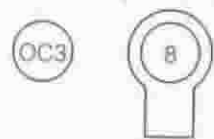

31e : Cowl wire RH
(To relay block D)

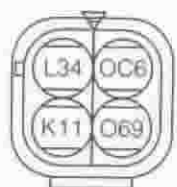

3A6 : Cowl wire RH
(To relay block E)



31m : Cowl wire RH
(To junction block A)



31n : Cowl wire RH
(To junction block B)



31q : Cowl wire RH
(To junction block D)

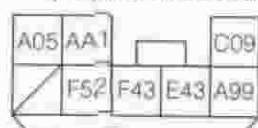

32s : Cowl wire LH
(To junction block H)



3M9 : Cowl wire LH
(To junction block C)

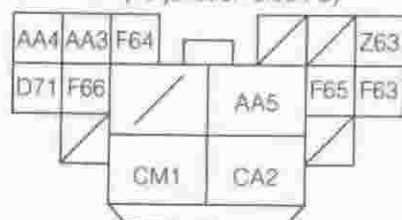

3L6 : Cowl wire RH
(To junction block F)

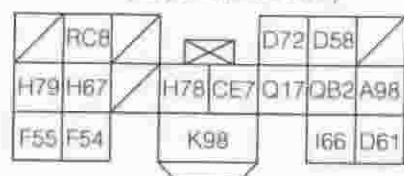

3L7 : Cowl wire RH
(To junction block G)

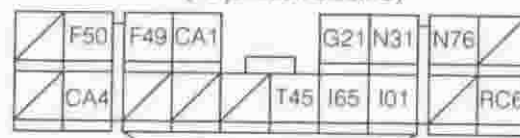

3Mp : Cowl wire LH
(To turn SW)

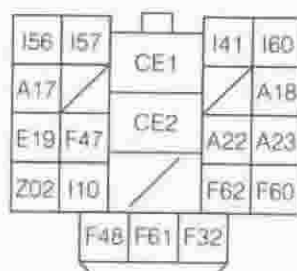

3Mb : Cowl wire LH
(To turn SW B)

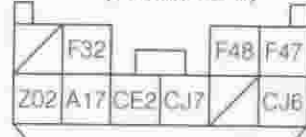

3Mc : Cowl wire LH
(To turn SW C)



3Aq : Cowl wire RH
(To cowl wire LH [3Mg])

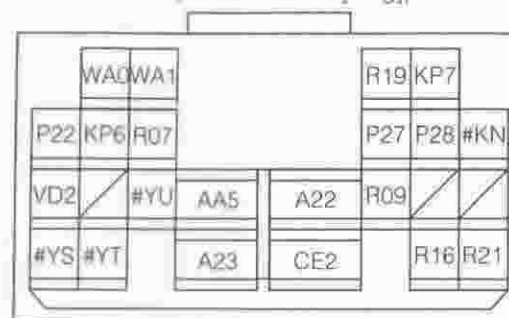

3Mg : Cowl wire LH
(To cowl wire RH [3Aq])

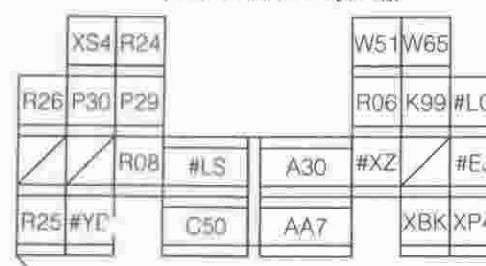

3Ar : Cowl wire RH
(To cowl wire LH [3Mf])

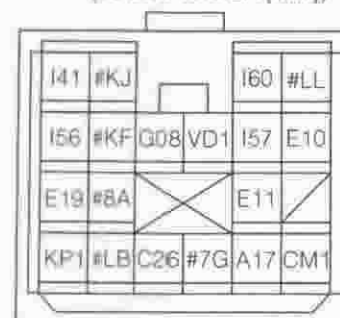

3Mf : Cowl wire LH
(To cowl wire RH [3Ar])

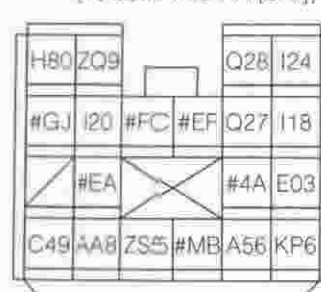

3Au : Cowl wire RH
(To meter 16P)

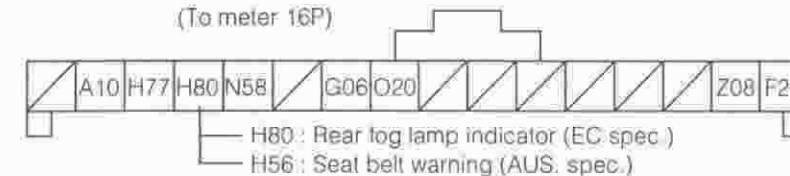

3Av : Cowl wire RH
(To meter 22P)



315 : Cowl wire RH
(To headlamp RH)

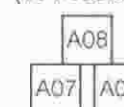

323 : Cowl wire LH
(To headlamp LH)

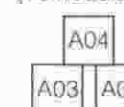

31w : Cowl wire RH
(To Ignition SW)



3V9 : Cowl wire RH
(To daylight relay A)

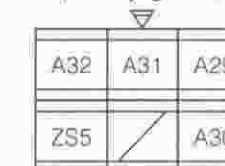

3Va : Cowl wire RH
(To daylight relay B)

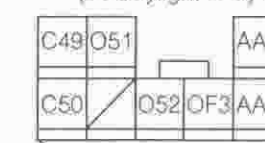

HEATER & VENTILATION (LHD)

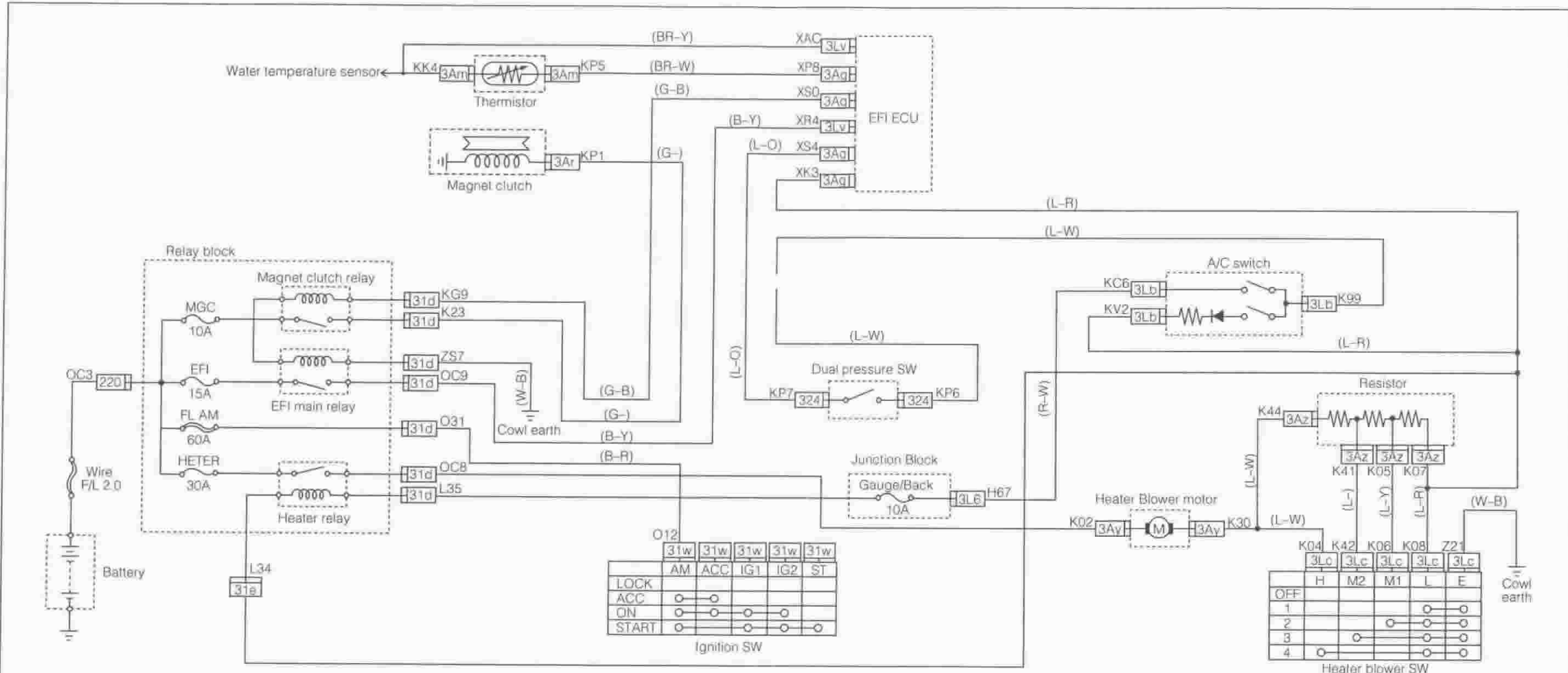

O12

	31w	31w	31w	31w	31w
	AM	ACC	IG1	IG2	ST
LOCK					
ACC					
ON					
START					

Ignition SW

	3Lc	3Lc	3Lc	3Lc	3Lc
	H	M2	M1	L	E
OFF					
1					
2					
3					
4					

Heater blower SW

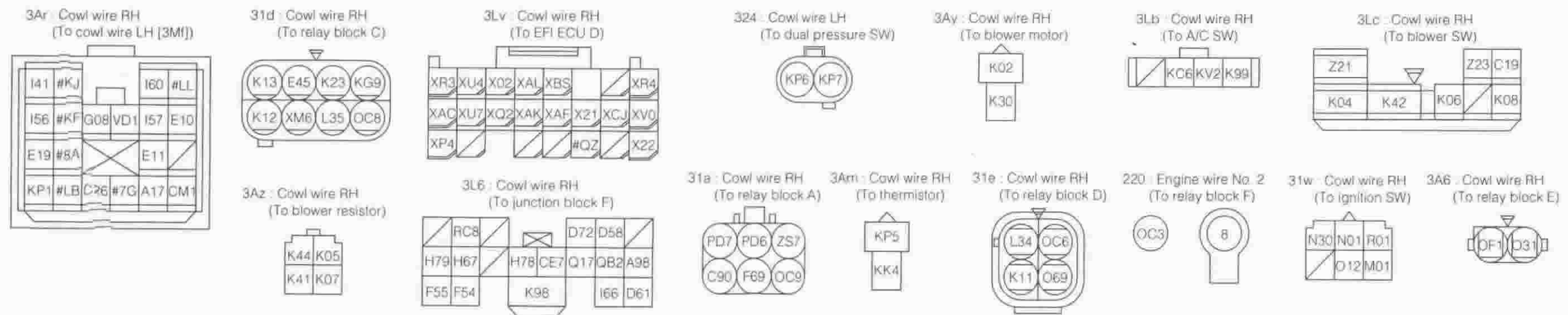

HEATER & VENTILATION (RHD)

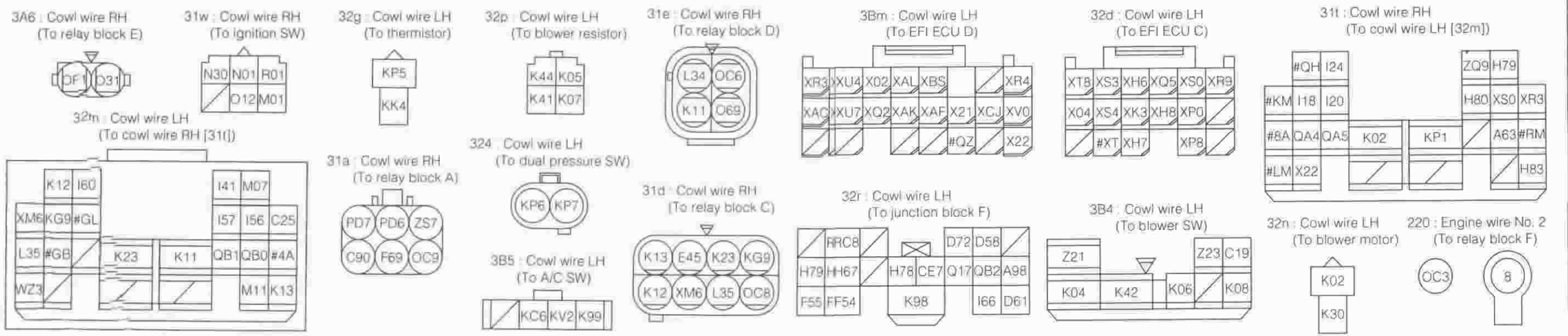
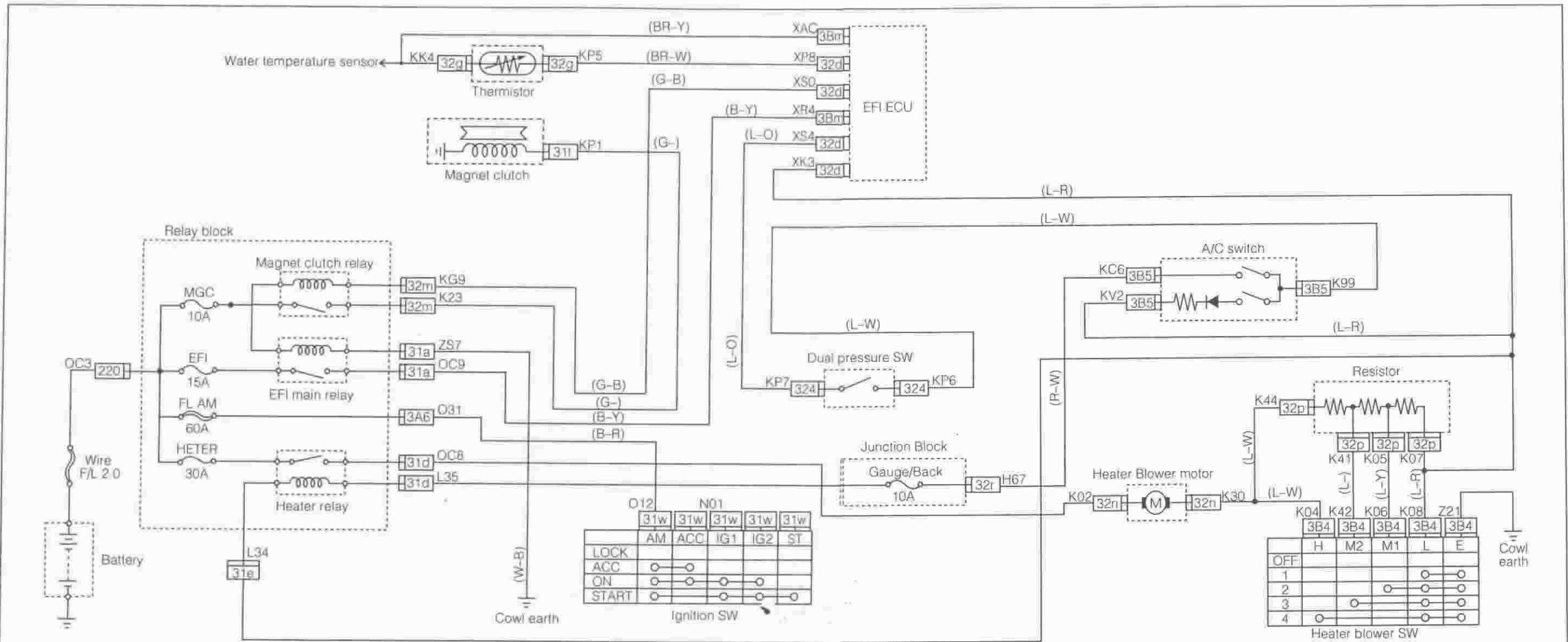

POWER WINDOW (LHD)

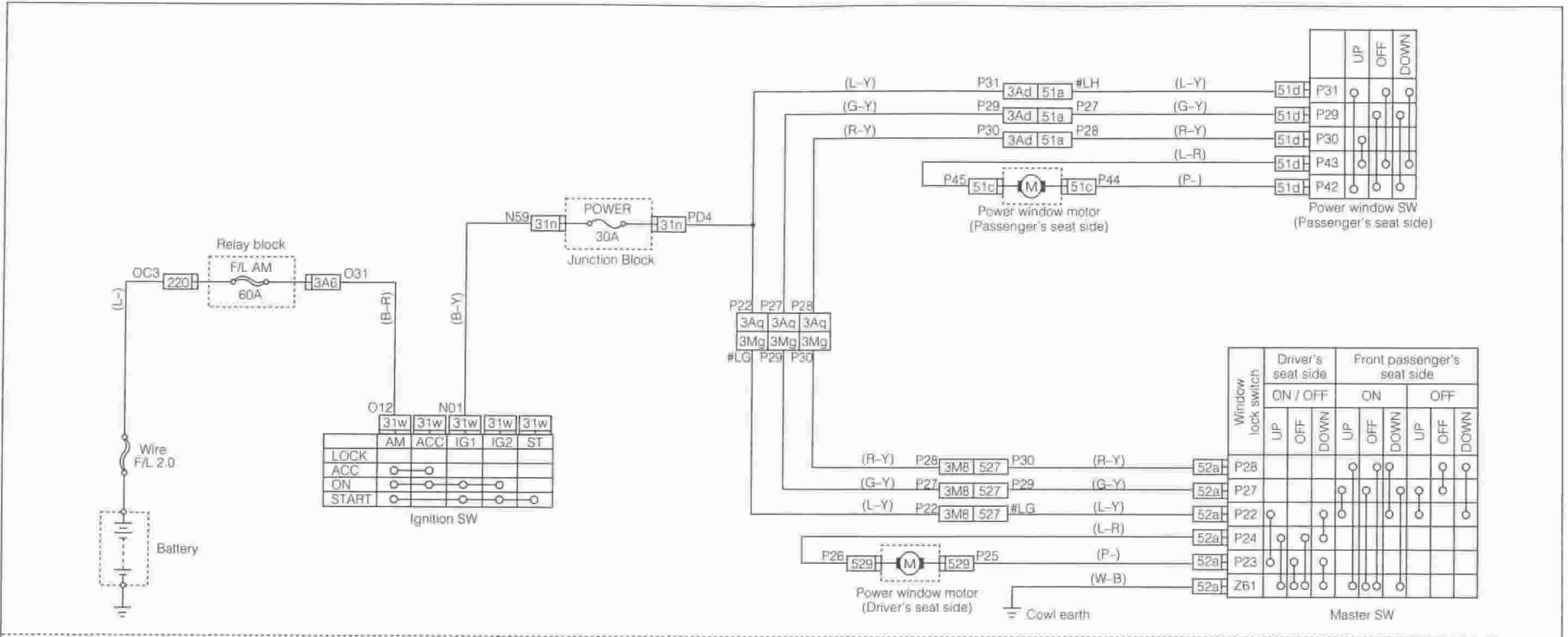

220 : Engine wire No. 2
(To relay block F)

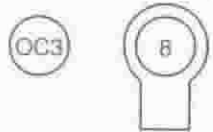

3A6 : Cowl wire RH
(To relay block E)



31w : Cowl wire RH
(To ignition SW)



3Aq : Cowl wire RH
(To cowl wire LH [3Mg])

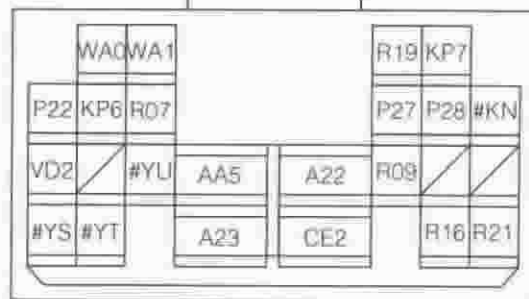

3Mg : Cowl wire LH
(To cowl wire RH [3Aq])

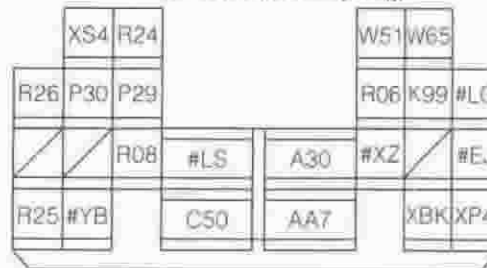

3Ad : Cowl wire RH
(To front door wire RH [51a])

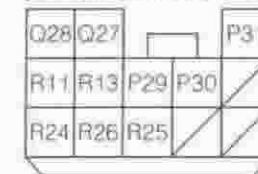

51a : Front door wire RH
(To cowl wire RH [3Ad])

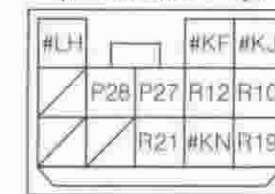

529 : Front door wire LH
(To power window motor LH)

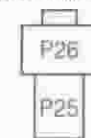

31n : Cowl wire RH
(To junction block B)



51d : Front door wire RH
(To front power window SW RH)

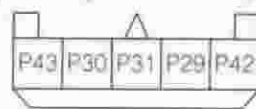

52a : Front door wire LH
(To power window SW)



3M8 : Cowl wire LH
(To front door wire LH [527])

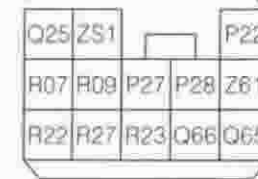

527 : Front door wire LH
(To cowl wire LH [3M8])

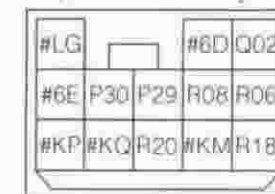

51c : Front door wire RH
(To power window motor RH)



POWER WINDOW (RHD)

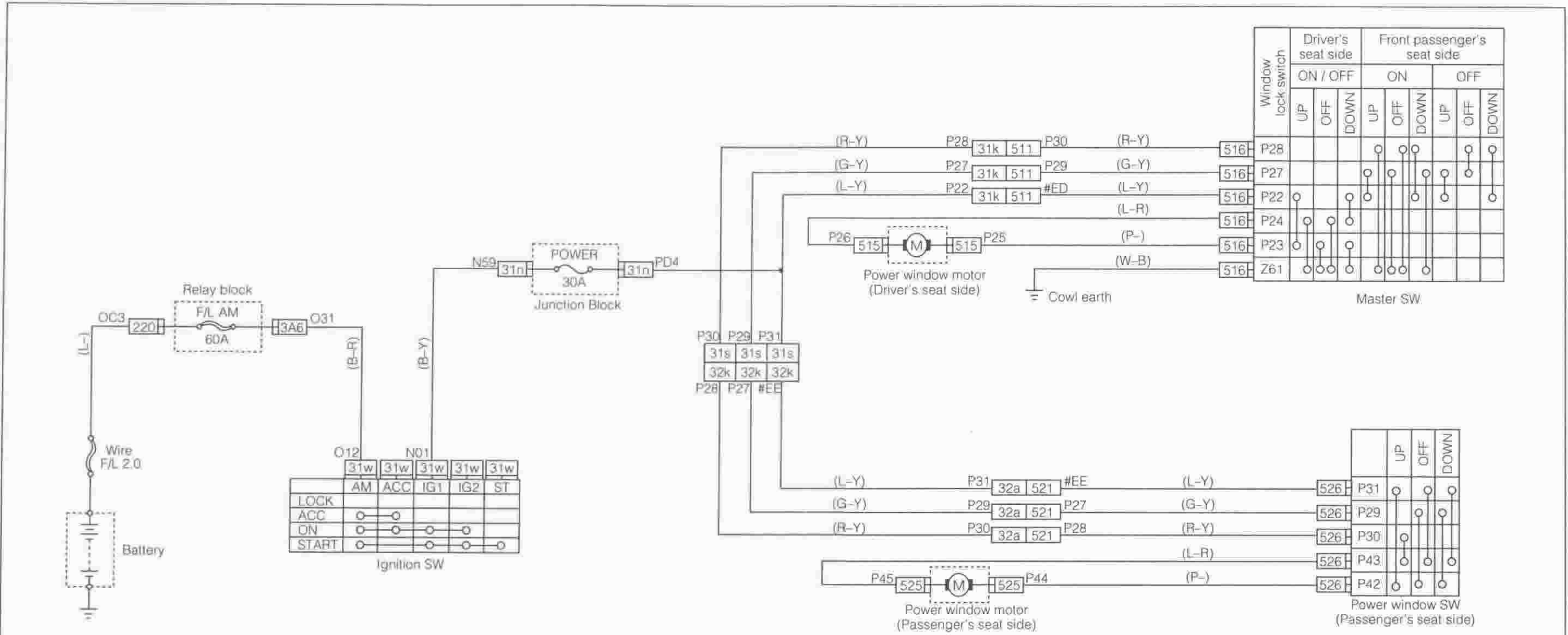

220 : Engine wire No. 2
(To relay block F)

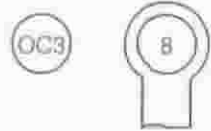

3A6 : Cowl wire RH
(To relay block E)



31w : Cowl wire RH
(To ignition SW)

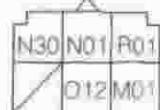

31s : Cowl wire RH
(To cowl wire LH [32k])

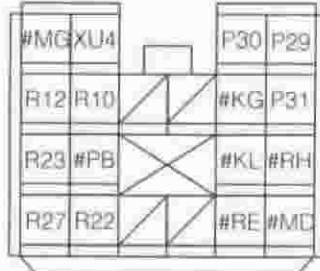

31n : Cowl wire RH
(To junction block B)



32k : Cowl wire LH
(To cowl wire RH [31s])

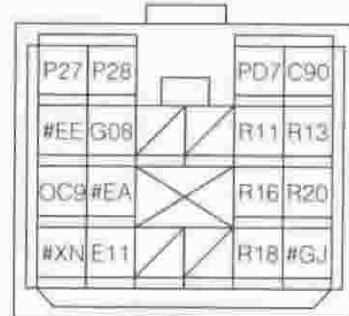

31k : Cowl wire RH
(To front door wire RH [511])

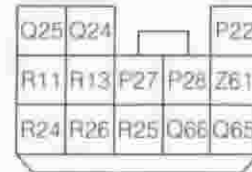

32a : Cowl wire LH
(To front door wire LH [521])



511 : Front door wire RH
(To cowl wire RH [31k])



521 : Front door wire LH
(To cowl wire LH [32a])

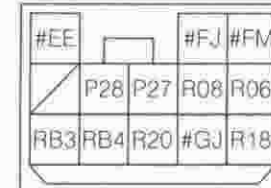

515 : Front door wire RH
(To power window motor LH)



525 : Front door wire LH
(To power window motor LH)



516 : Front door wire RH
(To master SW)

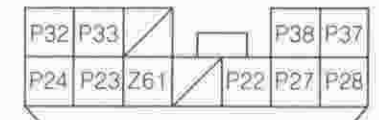

526 : Front door wire LH
(To front power window SW LH)

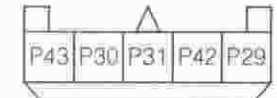

WIPER & WASHER (LHD)

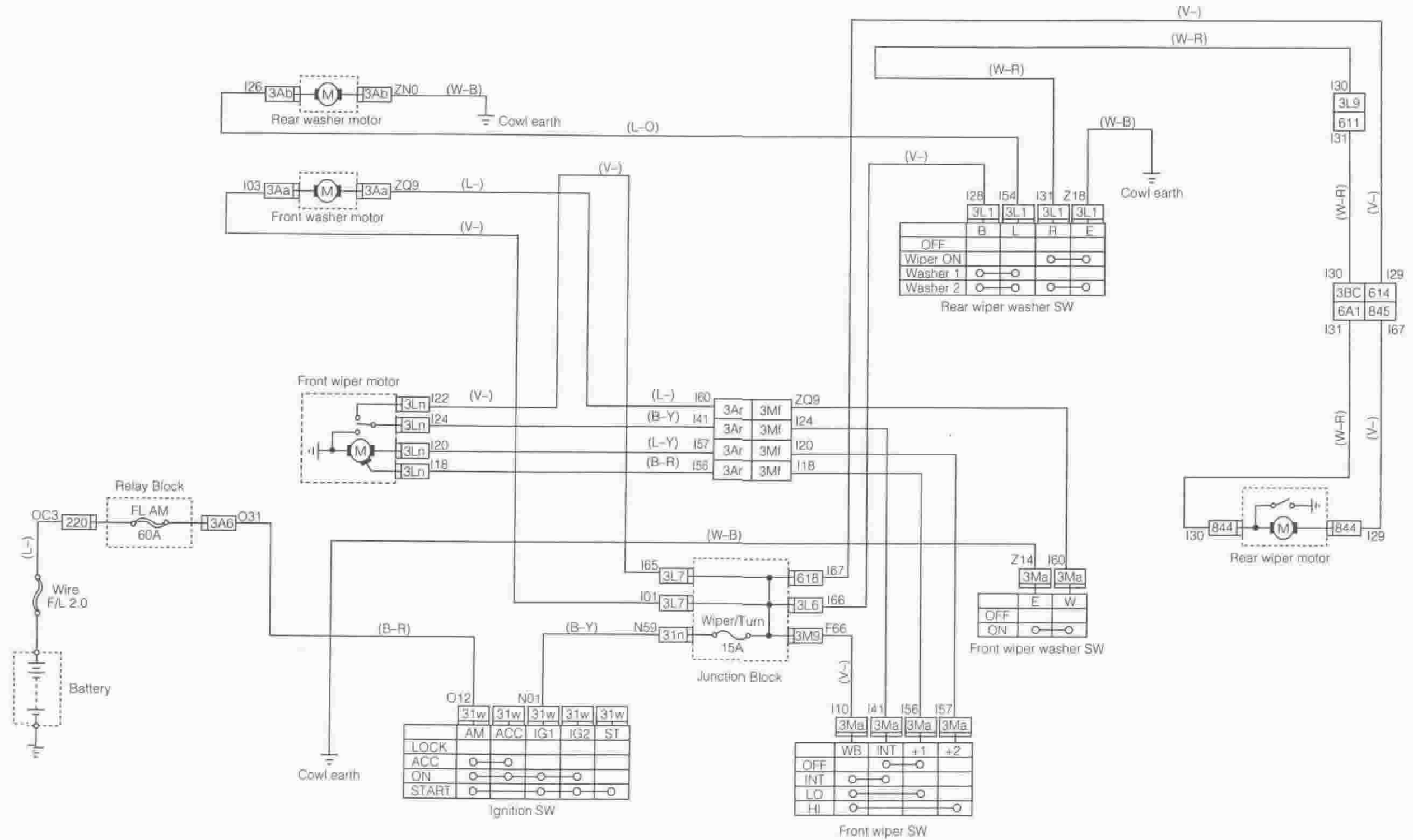

WIPER & WASHER (RHD)

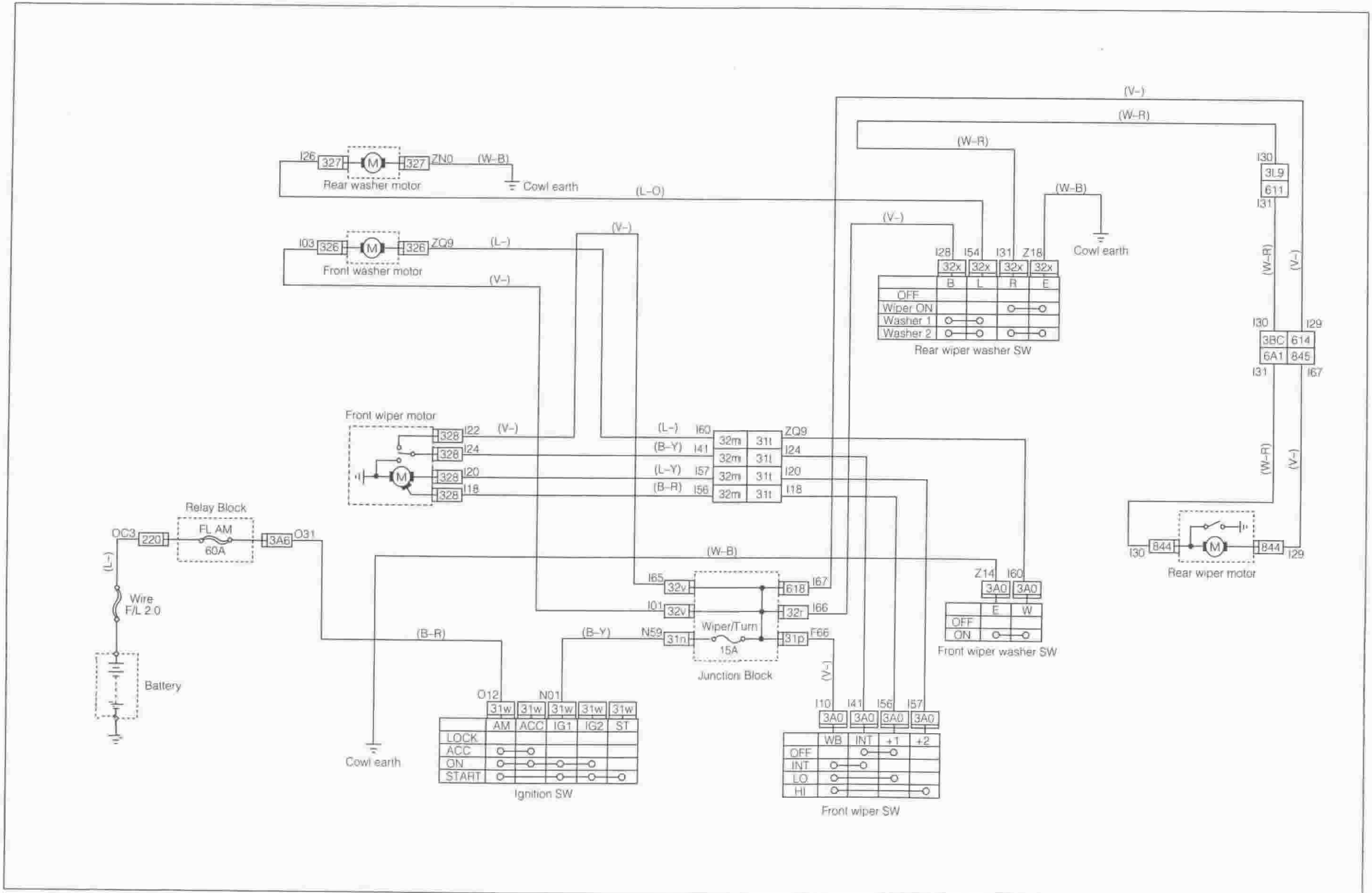

WIPER & WASHER (CONNECTORS)

220 : Engine wire No.2
(To relay block F)

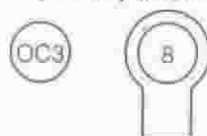

32v : Cowl wire LH
(To junction block G)



3A0 : Cowl wire RH
(To turn SW A)

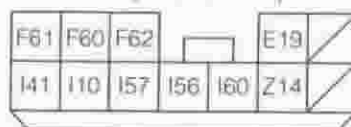

32x : Cowl wire LH
(To rear wiper SW)

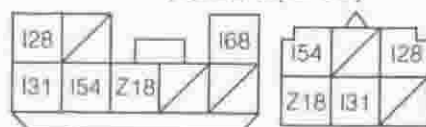

32r : Cowl wire LH
(To junction block F)

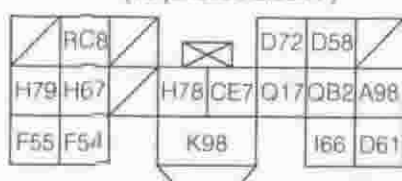

3M^a : Cowl wire LH
(To junction block C)

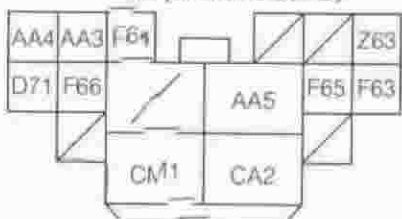

3Ar : Cowl wire RH
(To cowl wire LH [3M])

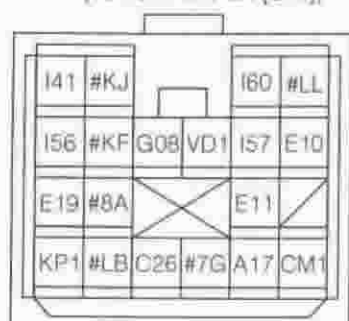

3M1 : Cowl wire LH
(To cowl wire RH [3Ar])

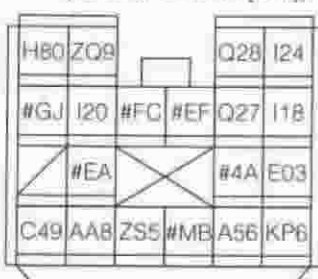

31p : Cowl wire RH
(To junction block C)

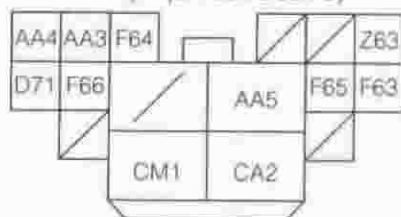

3L9 : Cowl wire RH
(To floor wire No. 1 [611])

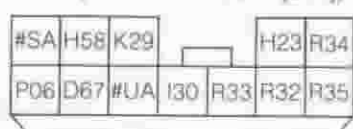

3Ma : Cowl wire LH
(To turn SW A)

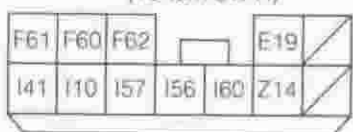

32m : Cowl wire LH
(To cowl wire RH [31])

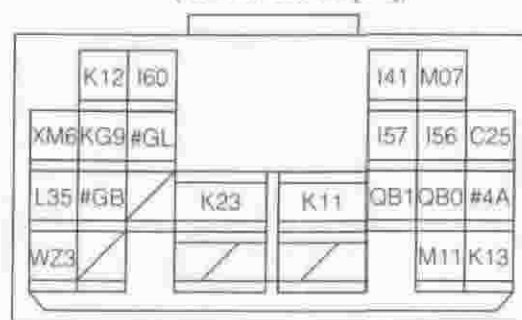

311 : Cowl wire RH
(To cowl wire LH [32m])

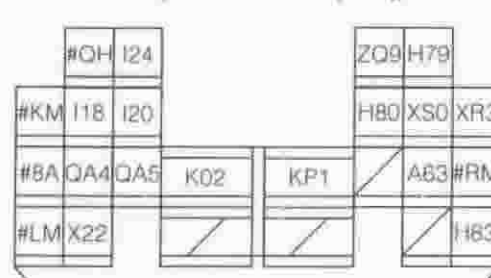

6A1 : Floor wire No. 1
(To cowl wire LH [3Bc])

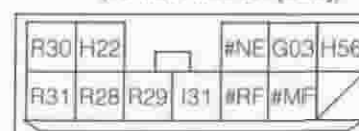

611 : Floor wire No. 1
(To cowl wire RH [3L9])



3L7 : Cowl wire RH
(To junction block G)

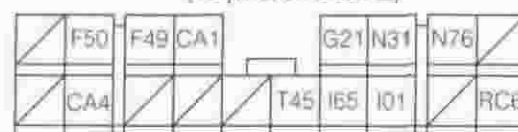

31n : Cowl wire RH
(To junction block B)



3L1 : Cowl wire RH
(To rear wiper SW)

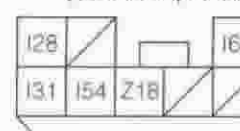

618 : Floor wire No. 1
(To junction block I)

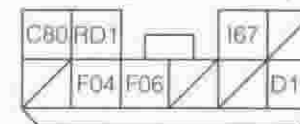

31w : Cowl wire RH
(To ignition SW)

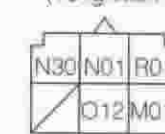

845 : Front door wire RH
(To floor wire No. 1 [614])

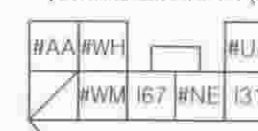

844 : Front door wire LH
(To rear wiper motor)



3Bc : Cowl wire LH
(To floor wire No. 1 [6A1])

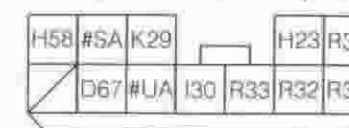

3L6 : Cowl wire RH
(To junction block F)



614 : Floor wire No. 1
(To back door wire No. 1 [845])

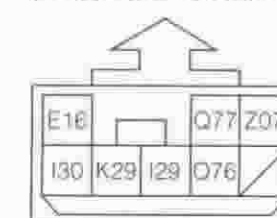

3Ab : Cowl wire RH
(To rear washer motor)



327 : Cowl wire LH
(To rear washer motor)



3Aa : Cowl wire RH
(To front washer motor)



326 : Cowl wire LH
(To front washer motor)



3A6 : Cowl wire RH
(To relay block E)



328 : Cowl wire RH
(To front wiper motor)



3La : Cowl wire RH
(To front wiper motor)

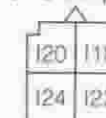

DEFOGGER (LHD)

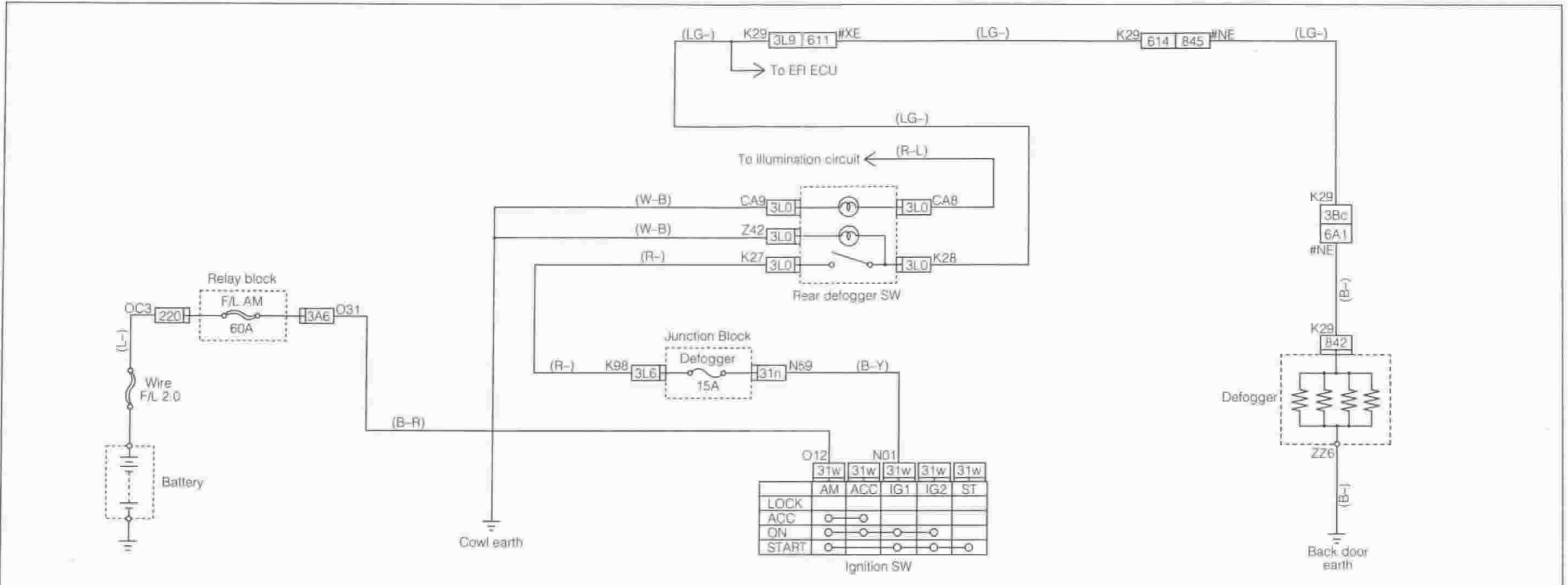

220 : Engine wire No. 2
(To relay block F)

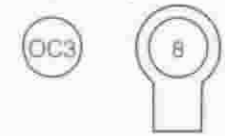

31n : Cowl wire RH
(To junction block B)

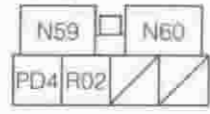

611 : Floor wire No. 1
(To cowl wire RH [3L9])



845 : Front door wire RH
(To floor wire No. 1 [614])

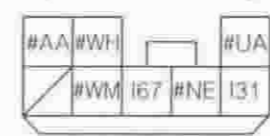

6A1 : Floor wire No. 1
(To cowl wire LH [3Bc])

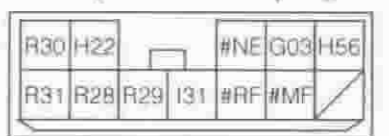

3A6 : Cowl wire RH
(To relay block E)



31w : Cowl wire RH
(To ignition SW)



614 : Floor wire No. 1
(To back door wire No. 1 [845])

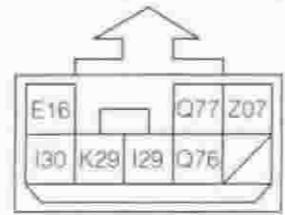

3Bc : Cowl wire LH
(To floor wire No. 1 [6A1])

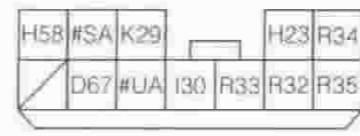

842 : Floor wire No. 1
(To rear window wire No. 1)

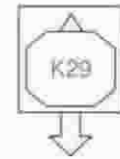

3L0 : Cowl Wire RH
(To rear defogger SW)

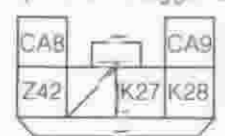

3L9 : Cowl wire RH
(To floor wire No. 1 [611])

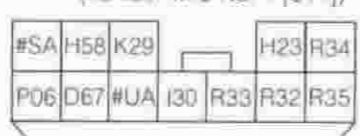

3L6 : Cowl wire RH
(To junction block F)

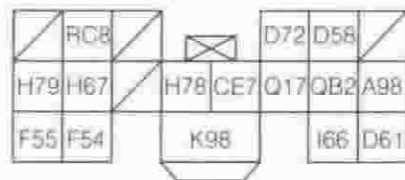

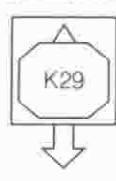
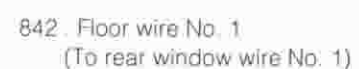
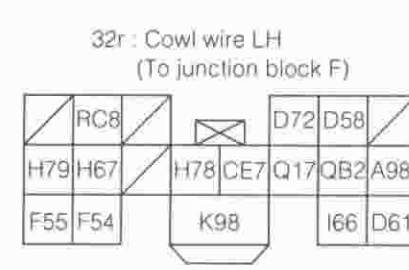
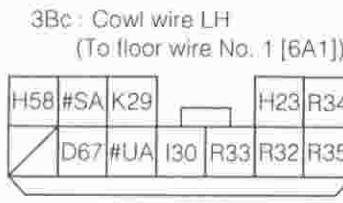
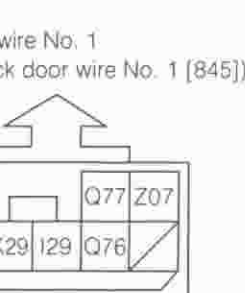
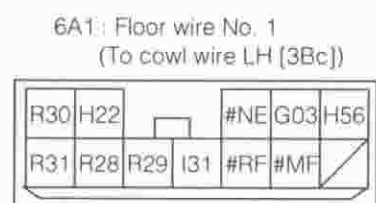
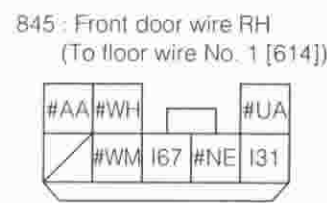
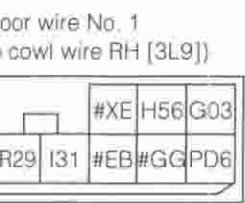
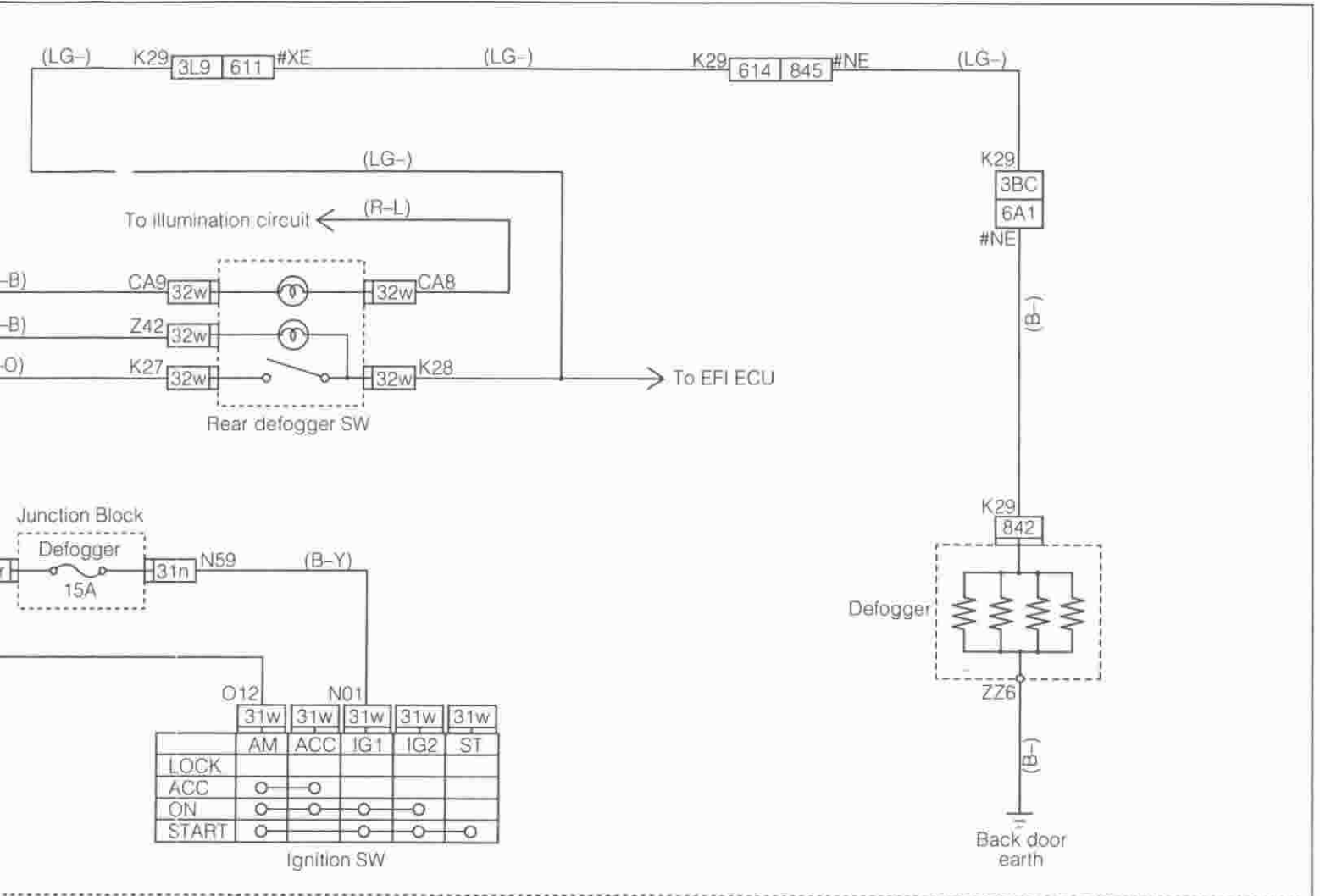

CIGARETTE LIGHTER, HORN, RADIO (LHD)

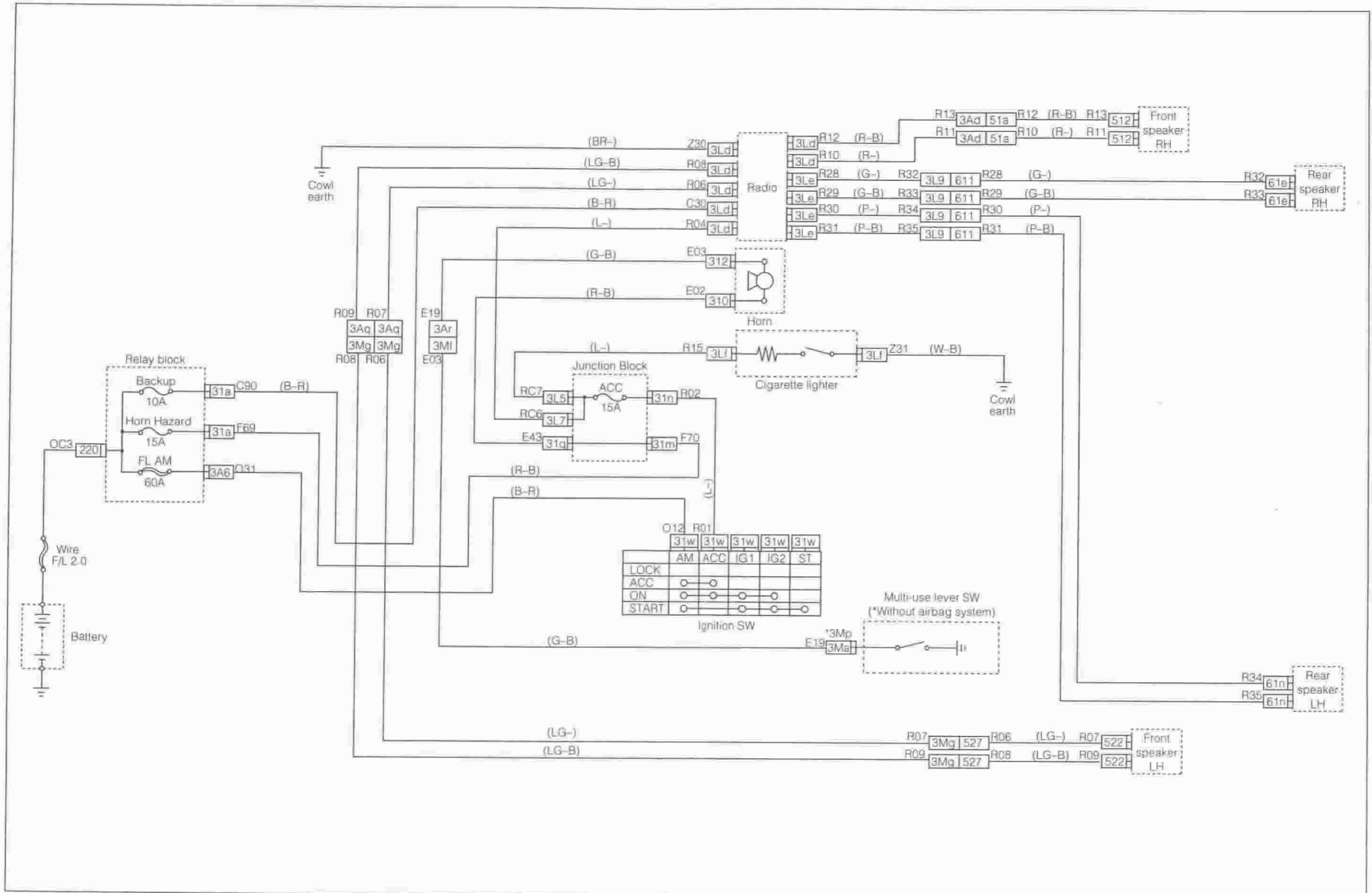

CIGARETTE LIGHTER, HORN, RADIO (RHD)

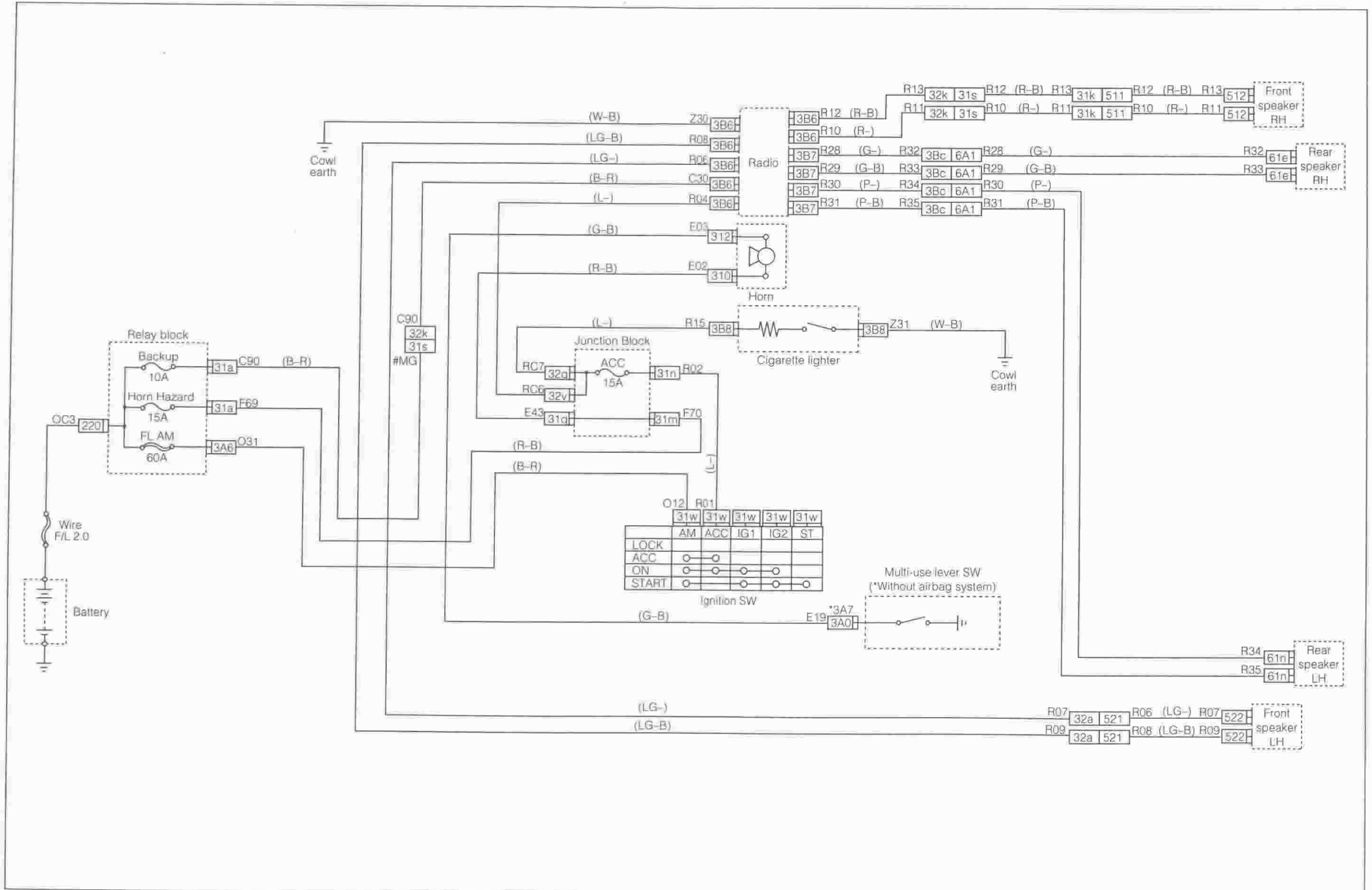

CIGARETTE LIGHTER, HORN, RADIO (CONNECTORS)

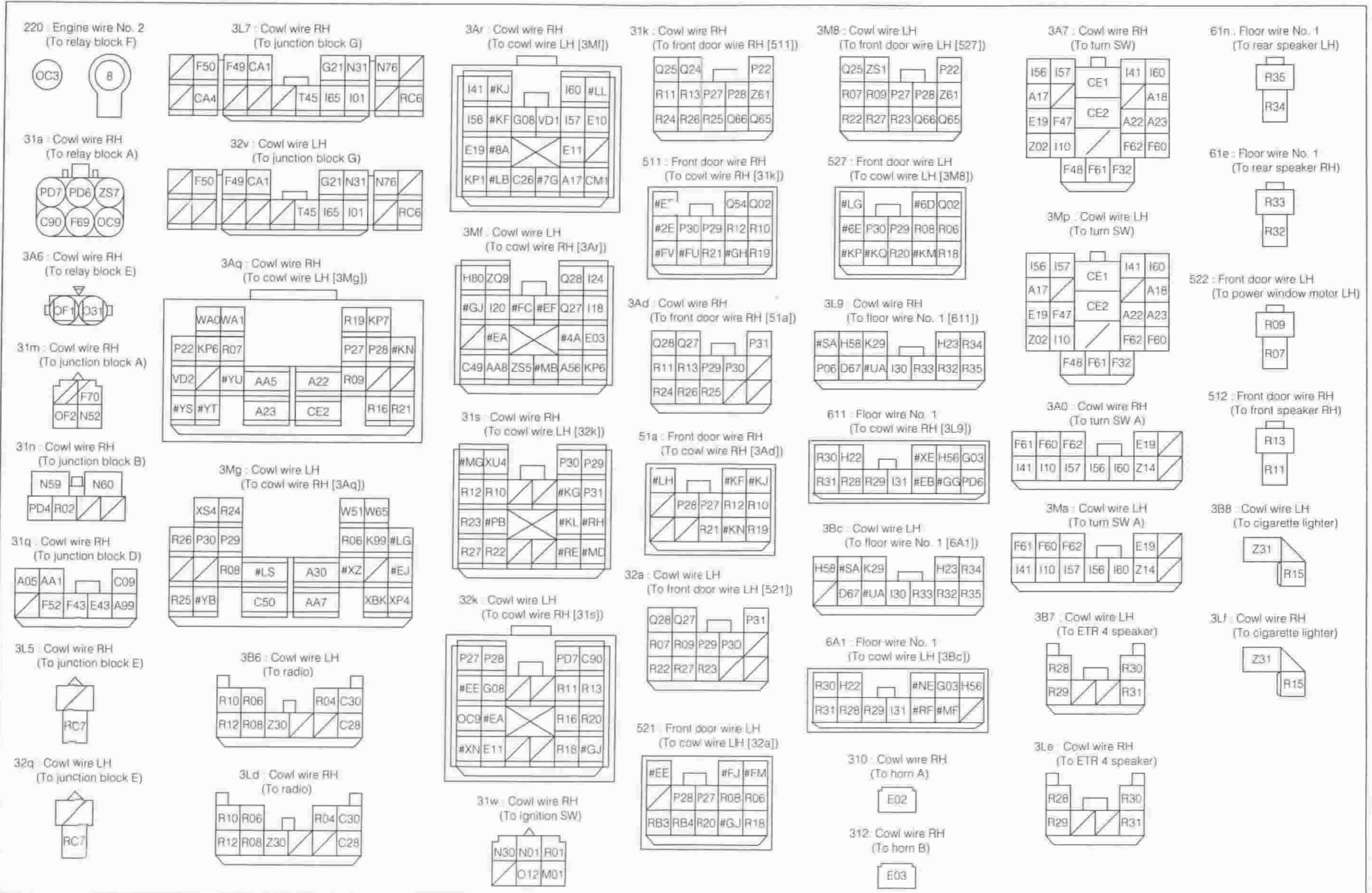

REAR VIEW MIRROR

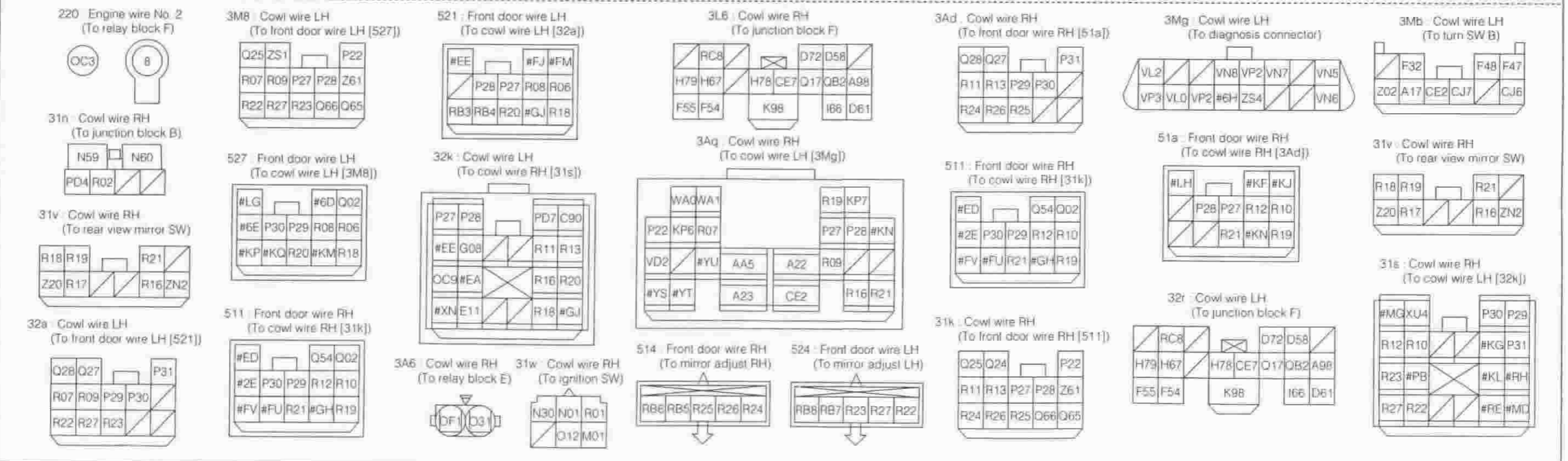
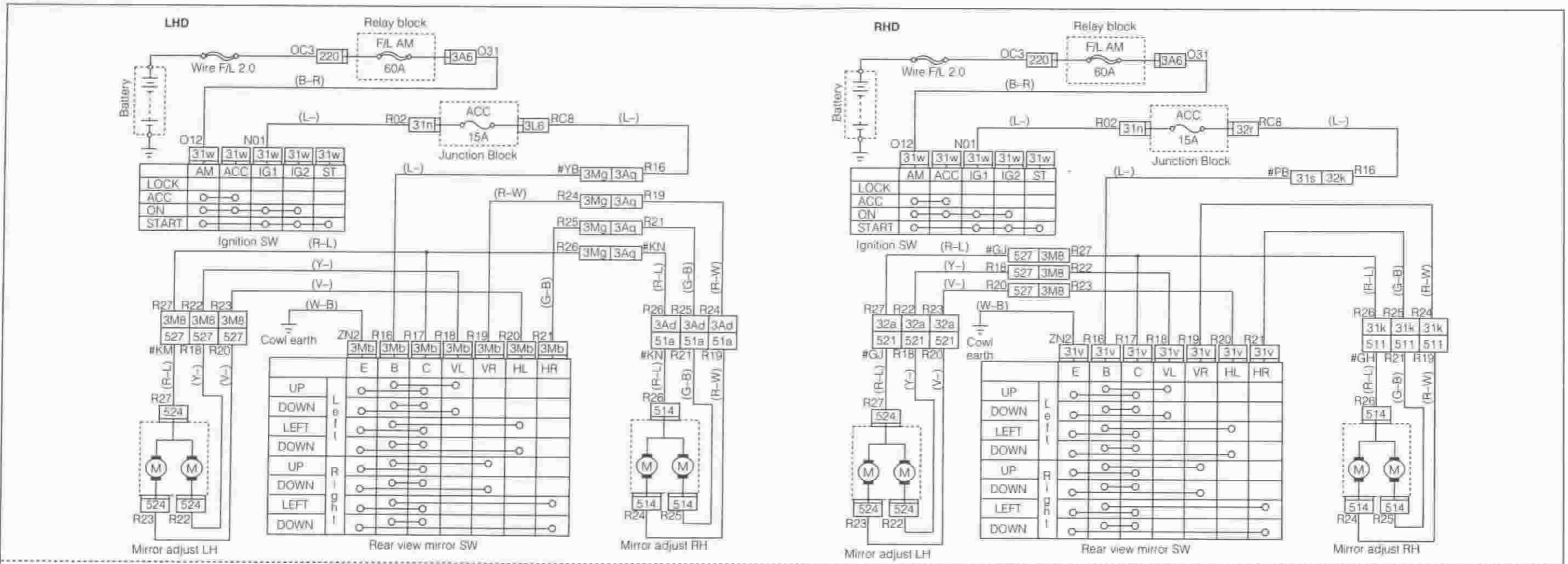

CLOCK

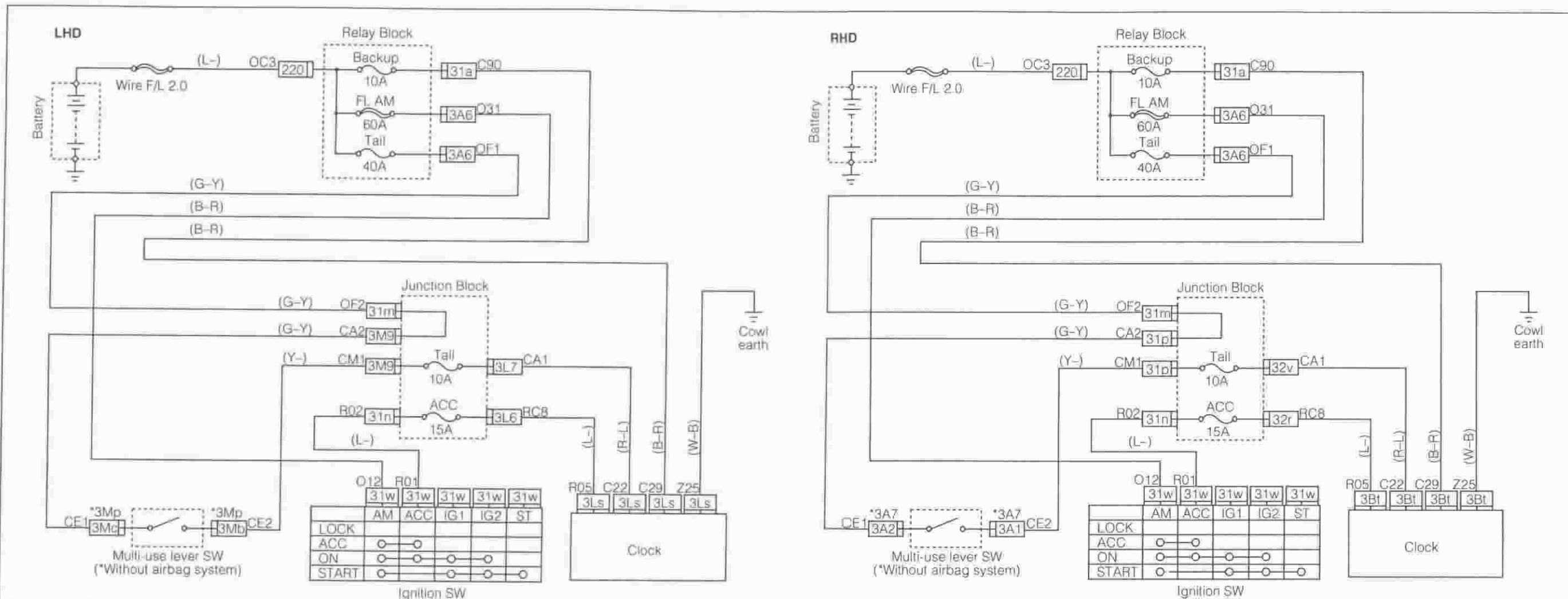

220 : Engine wire No. 2
(To relay block F)

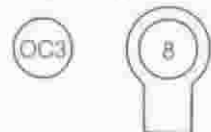

3L7 : Cowl wire RH
(To junction block G)

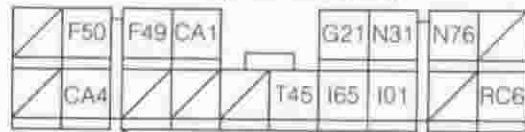

32v : Cowl wire LH
(To junction block G)

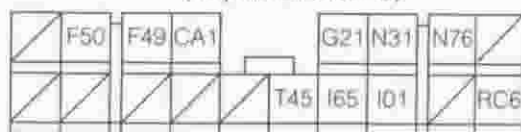

3L6 : Cowl wire RH
(To junction block F)



3A7 : Cowl wire RH
(To turn SW)



3Mp : Cowl wire LH
(To turn SW)



3A6 : Cowl wire RH
(To relay block E)



31p : Cowl wire RH
(To junction block C)



3M9 : Cowl wire LH
(To junction block C)



32r : Cowl wire LH
(To junction block F)



3A2 : Cowl wire RH
(To turn SW C)



3Mc : Cowl wire LH
(To turn SW C)



31a : Cowl wire RH
(To relay block A)

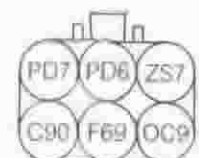

31n : Cowl wire RH
(To junction block B)



31m : Cowl wire RH
(To junction block A)



31w : Cowl wire RH
(To ignition SW)

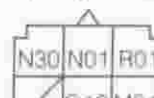

3Ls : Cowl wire RH
(To clock)



3Bt : Cowl wire LH
(To clock)



3A1 : Cowl wire RH
(To turn SW B)

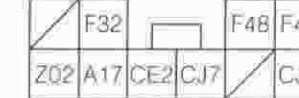

3Mb : Cowl wire LH
(To turn SW B)



ITC 1/2 (LHD)

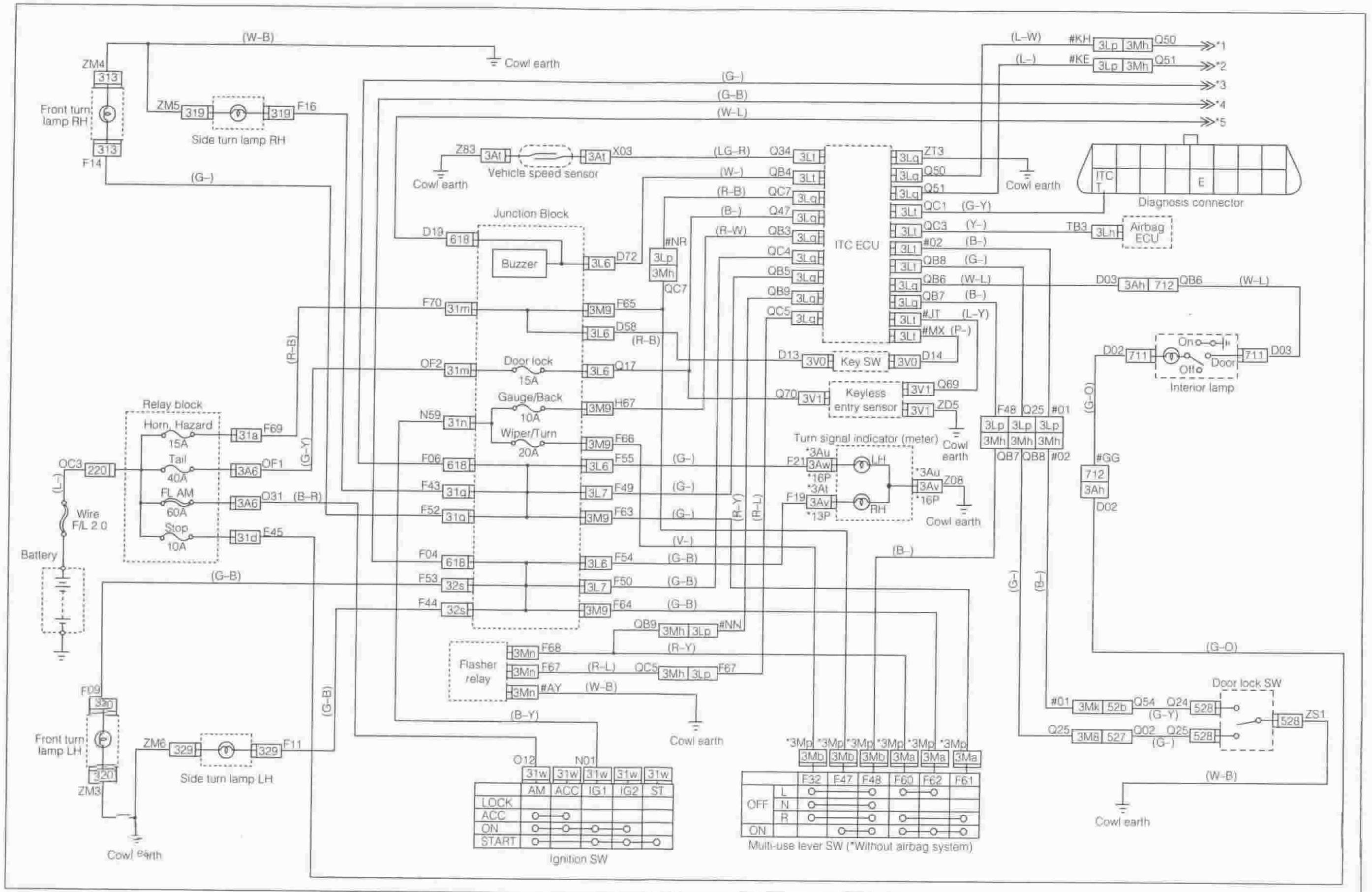

ITC 2/2 (LHD)

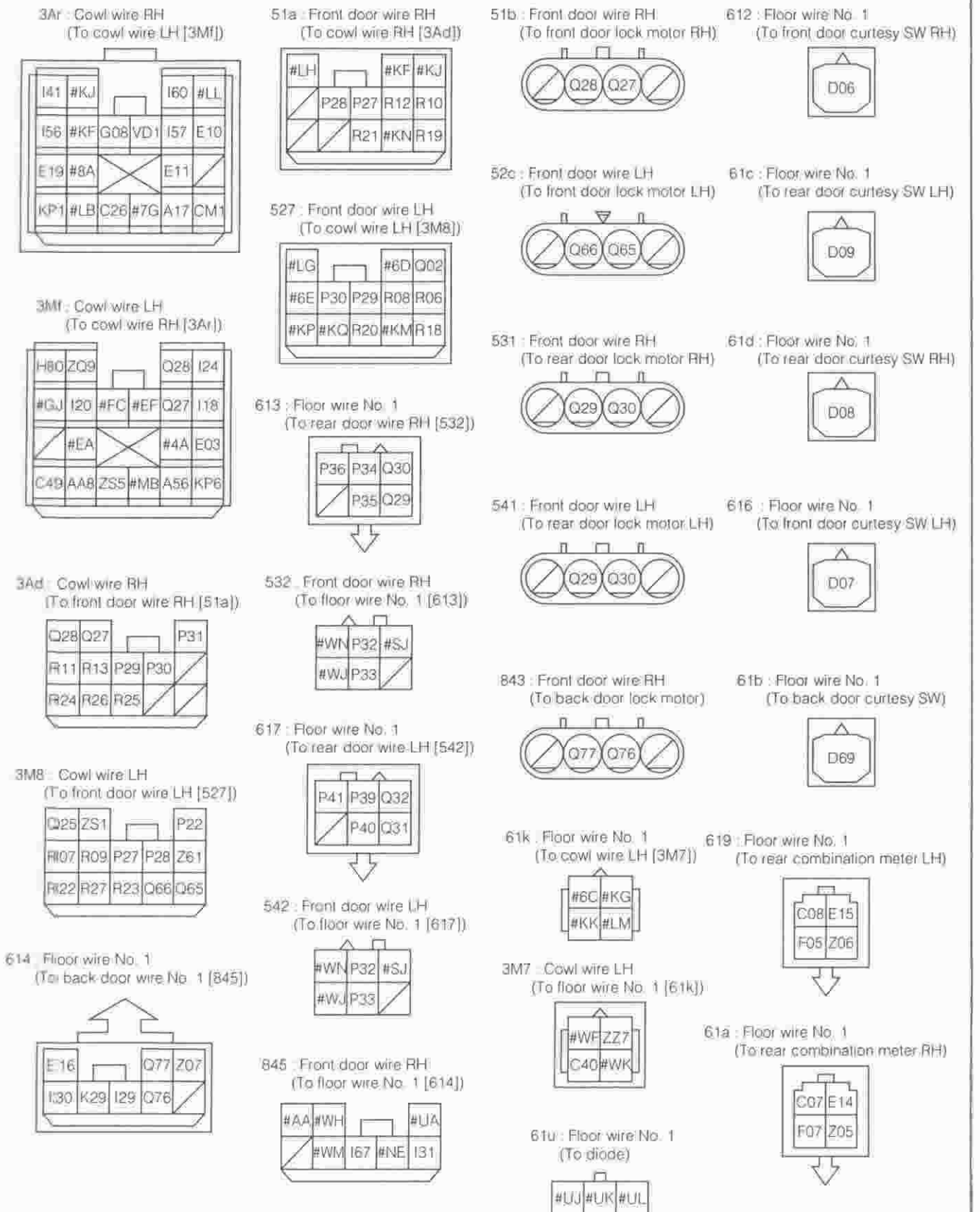
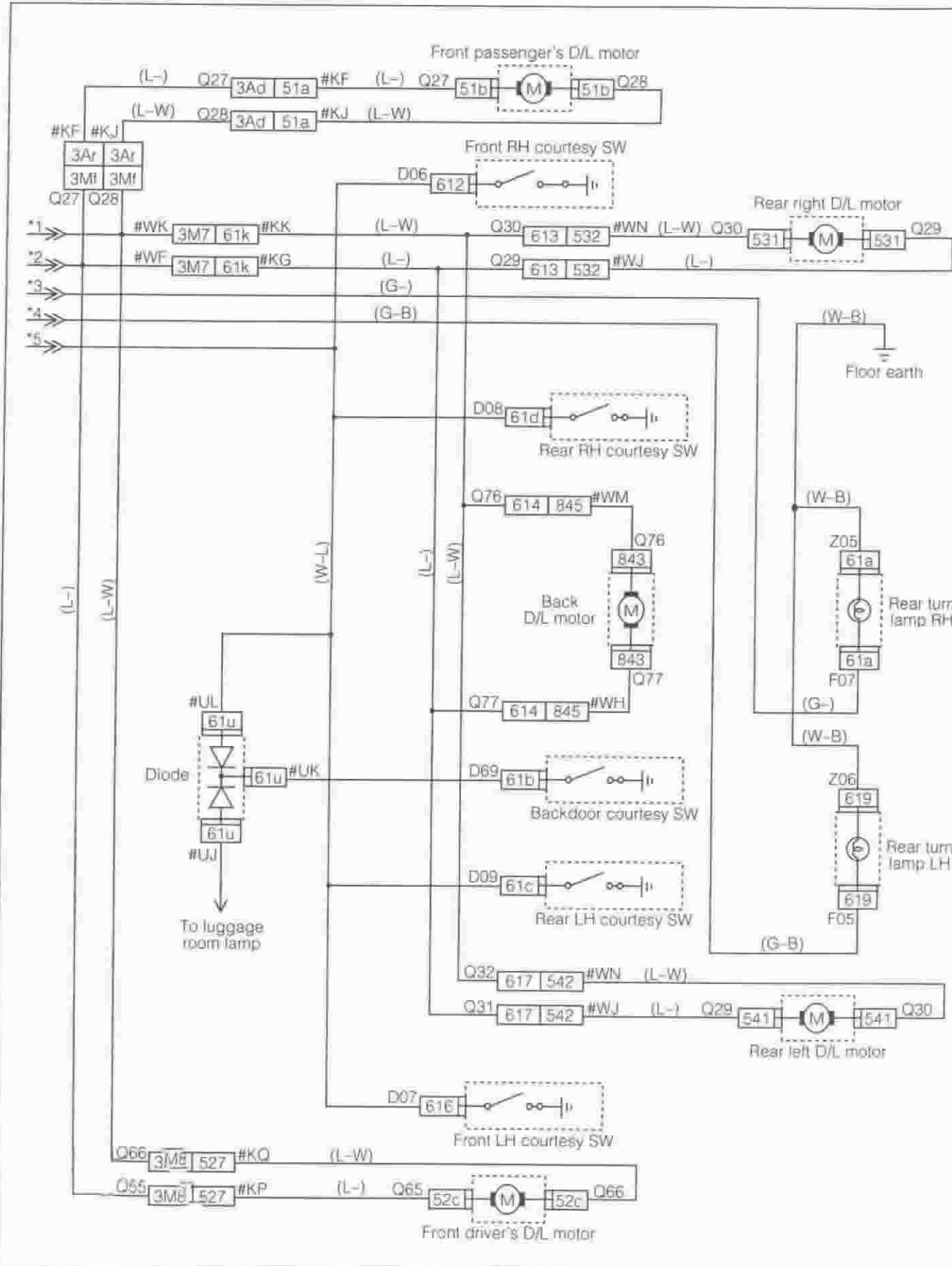

ITC 1/2 (RHD)

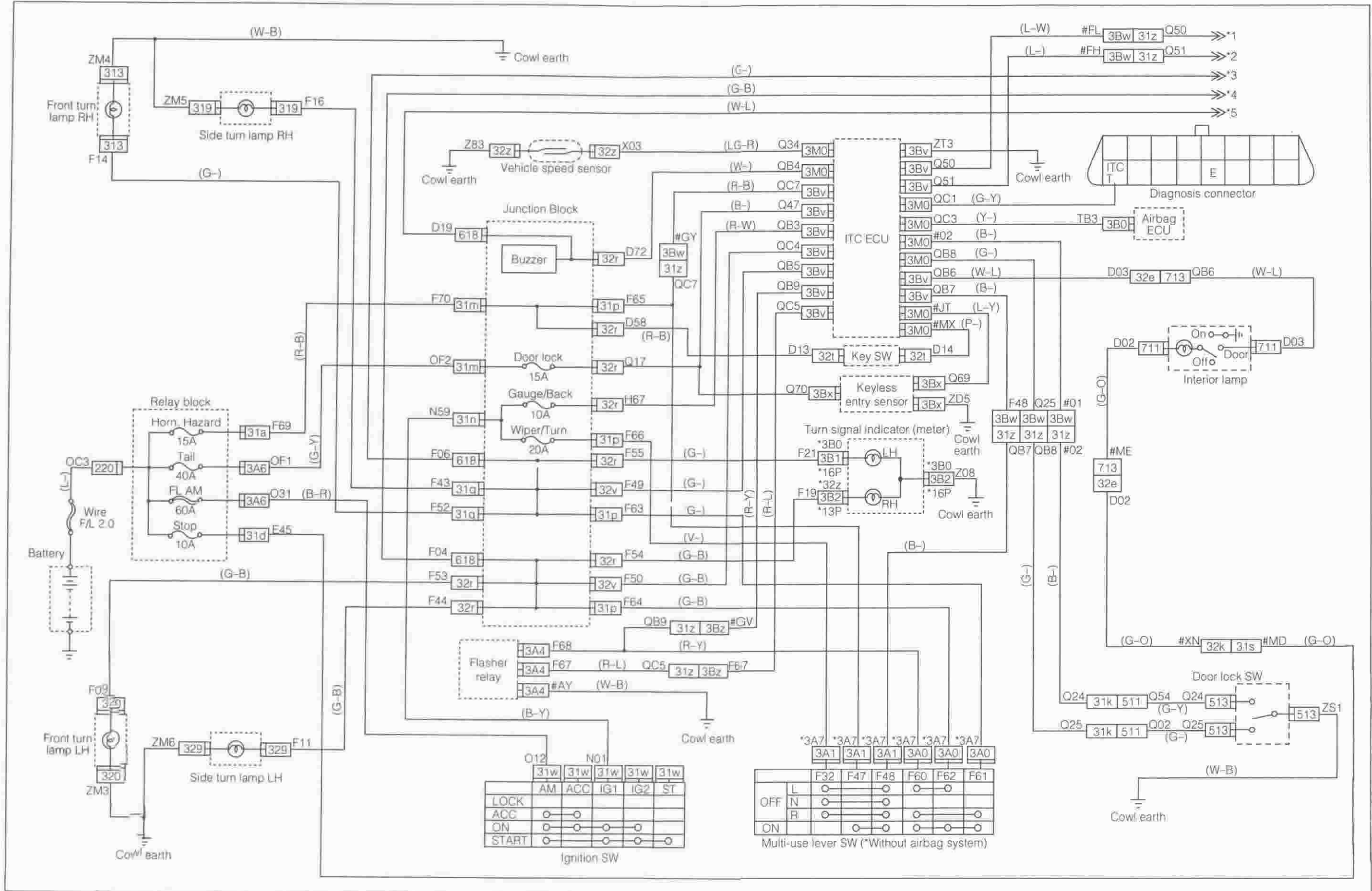

ITC 2/2 (RHD)

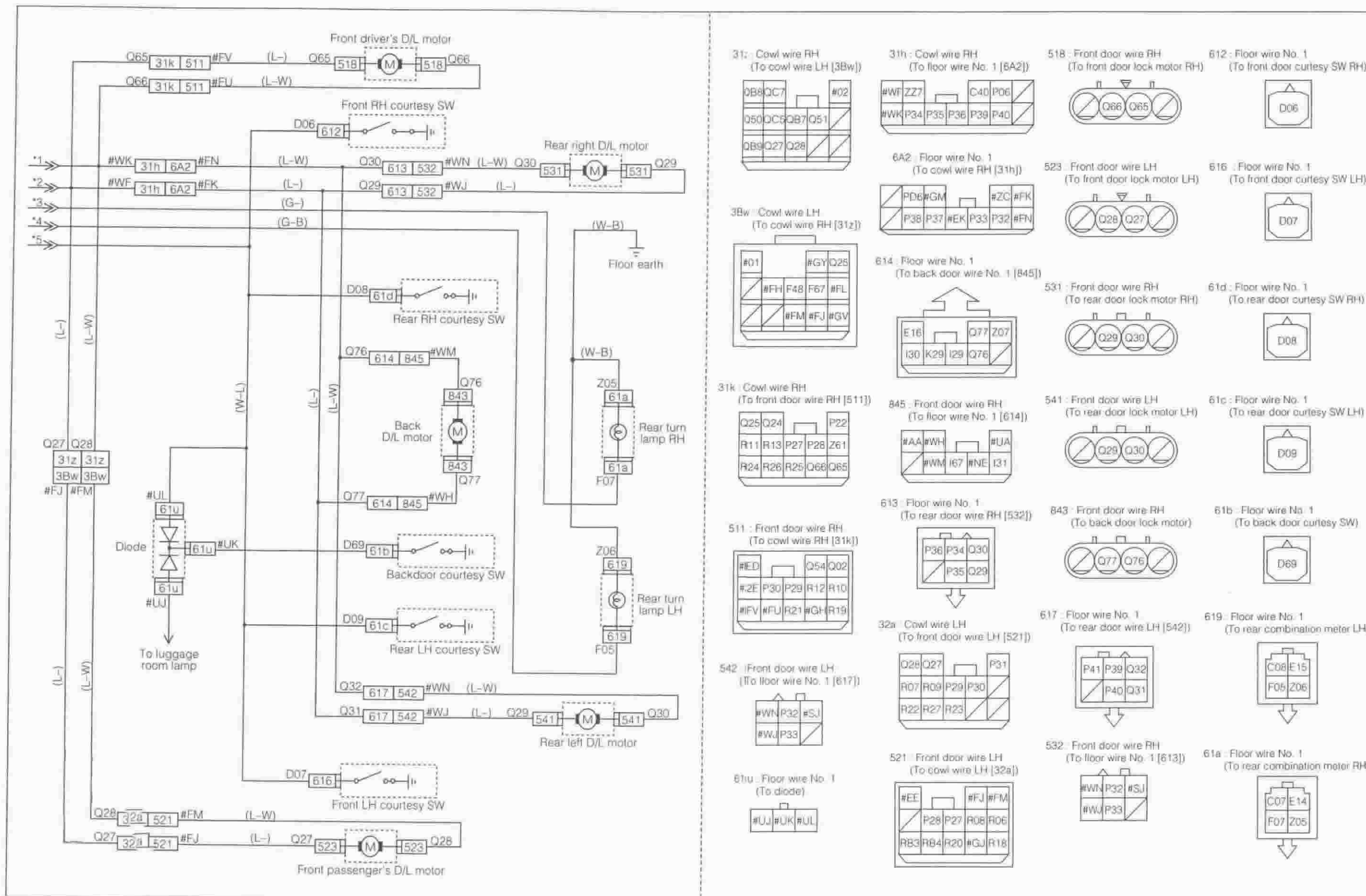

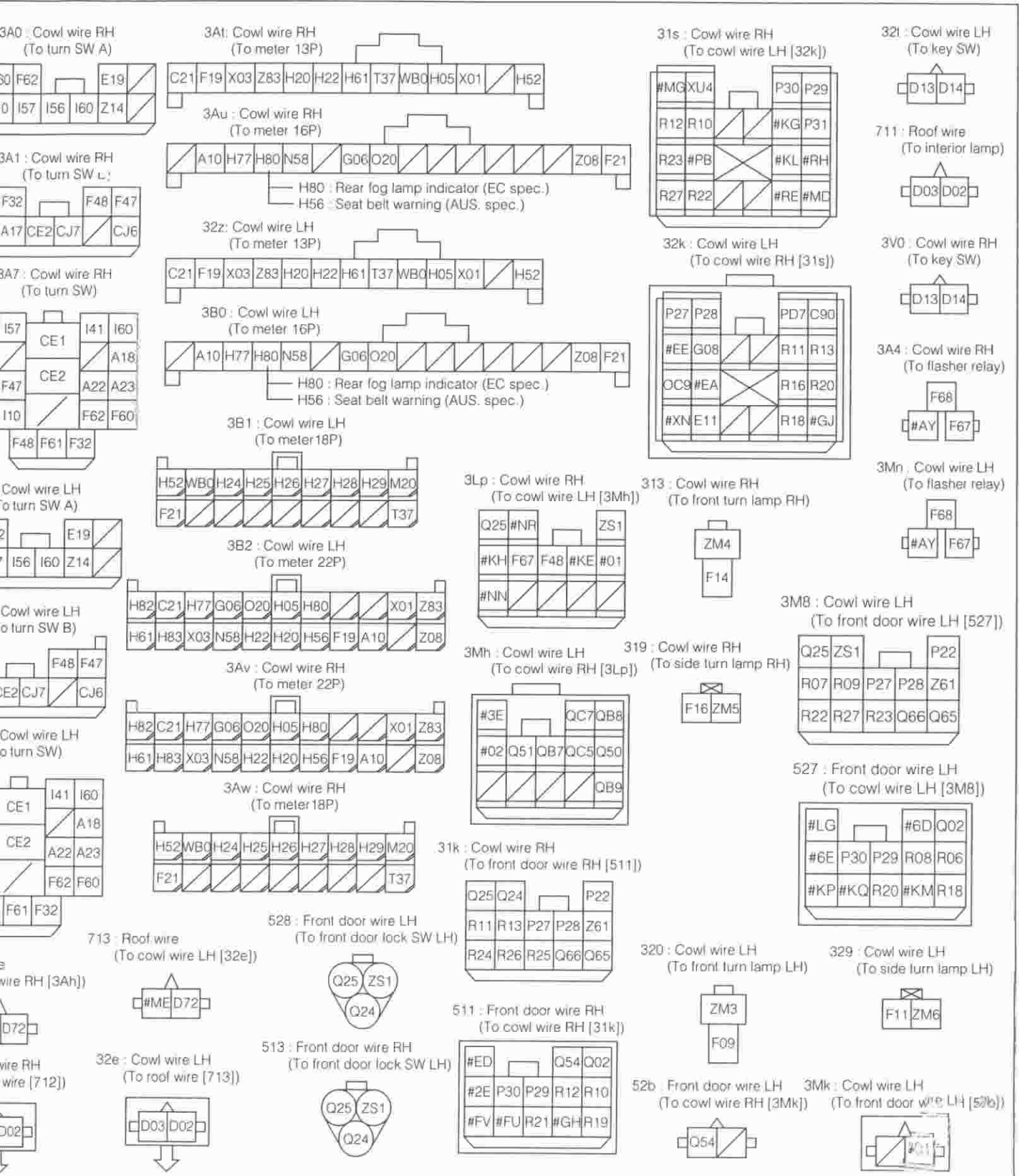

IMMOBILIZER SYSTEM

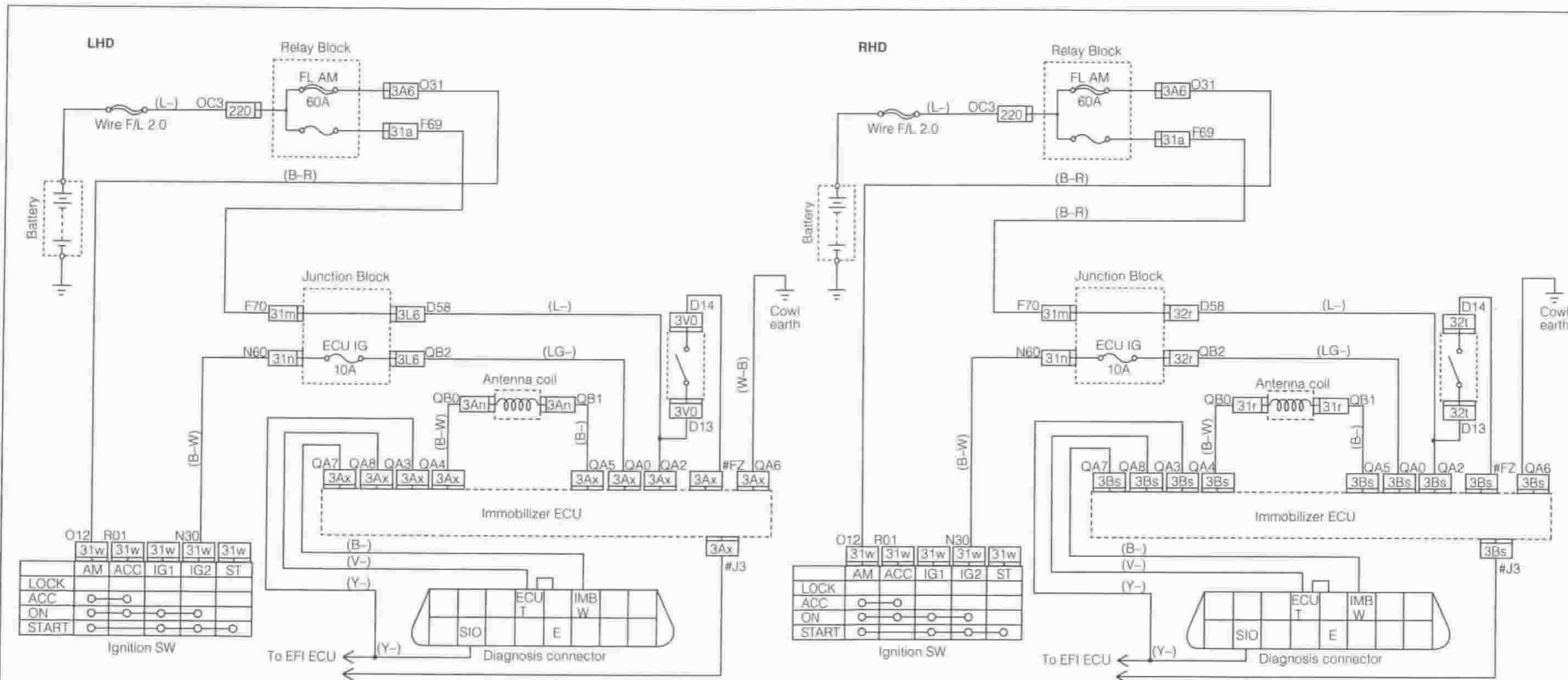

220 : Engine wire No. 2
(To relay block F)

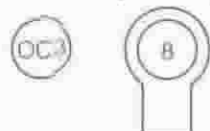

3A6 : Cowl wire RH
(To relay block E)



31n : Cowl wire RH
(To junction block B)

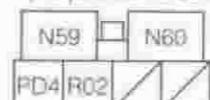

3L6 : Cowl wire RH
(To junction block F)

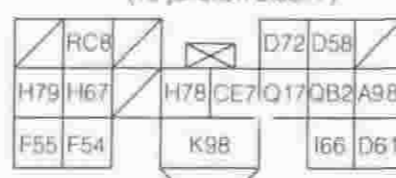

31w : Cowl wire RH
(To ignition SW)



32r : Cowl wire LH
(To junction block F)

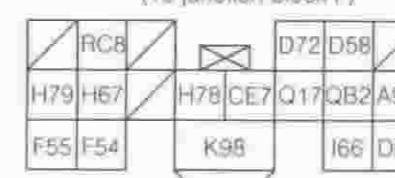

31r : Cowl wire RH
(To antenna coil)



31a : Cowl wire RH
(To relay block A)

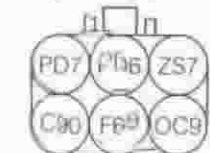

31m : Cowl wire RH
(To junction block A)



3An : Cowl wire RH
(To antenna coil)



3Ax : Cowl wire RH
(To immobilizer ECU)

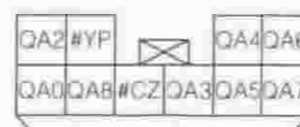

3Bs : Cowl wire LH
(To immobilizer ECU)



3V0 : Cowl wire RH
(To key SW)



32i : Cowl wire LH
(To key SW)



SRS AIR BAG SYSTEM (LHD)

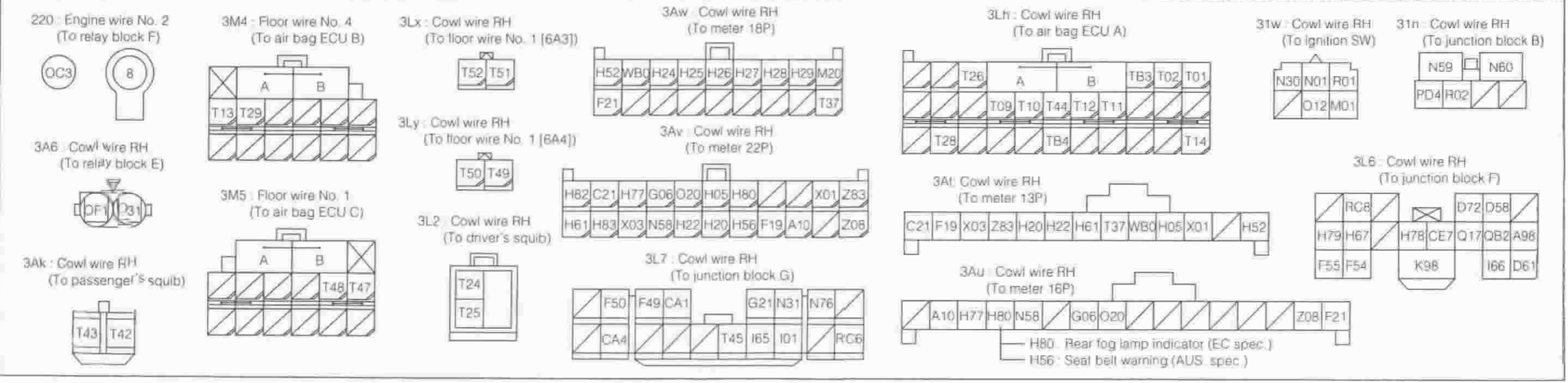
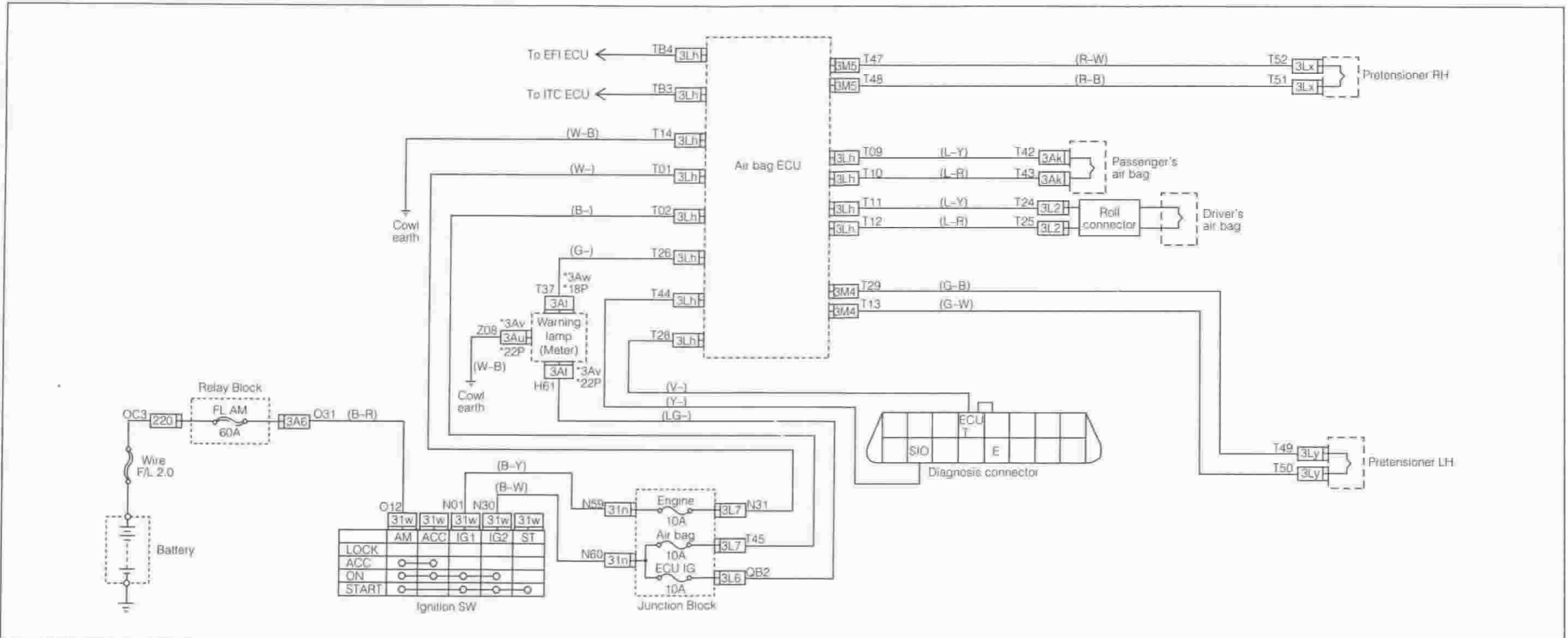

SRS AIR BAG SYSTEM (RHD)

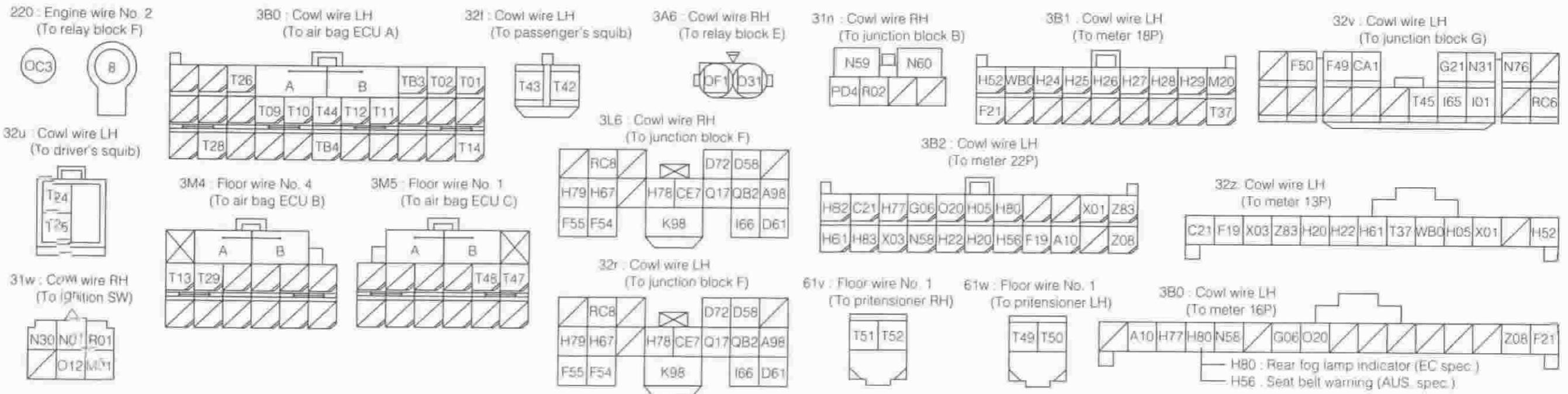
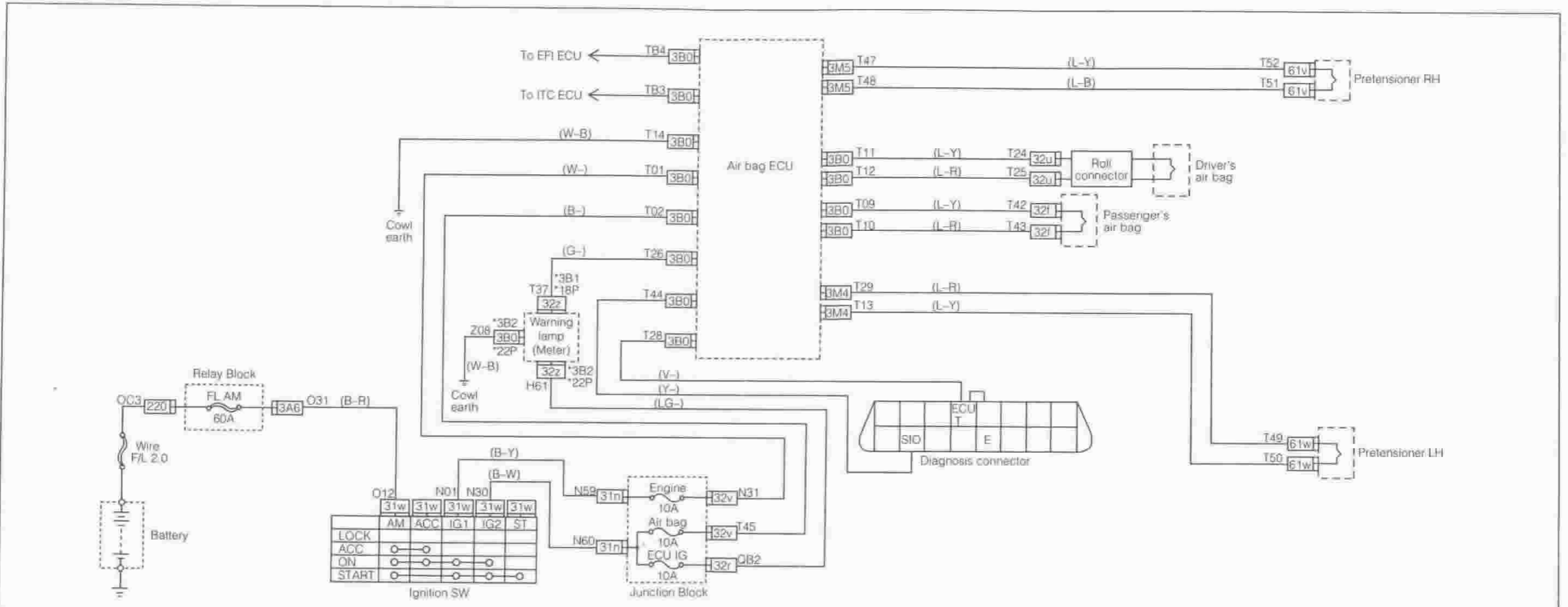

LOCATION OF CONNECTOR
LHD vehicle

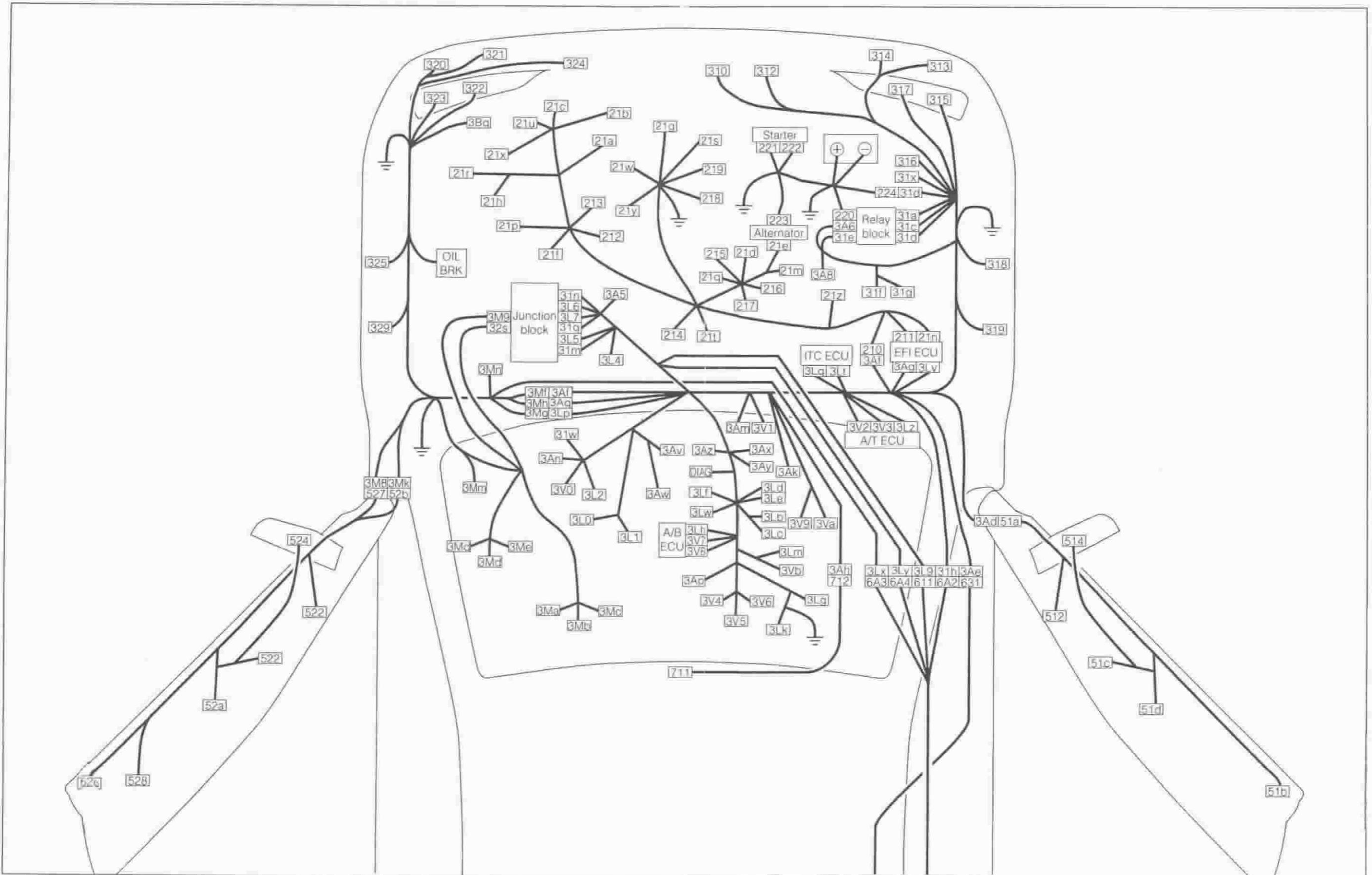

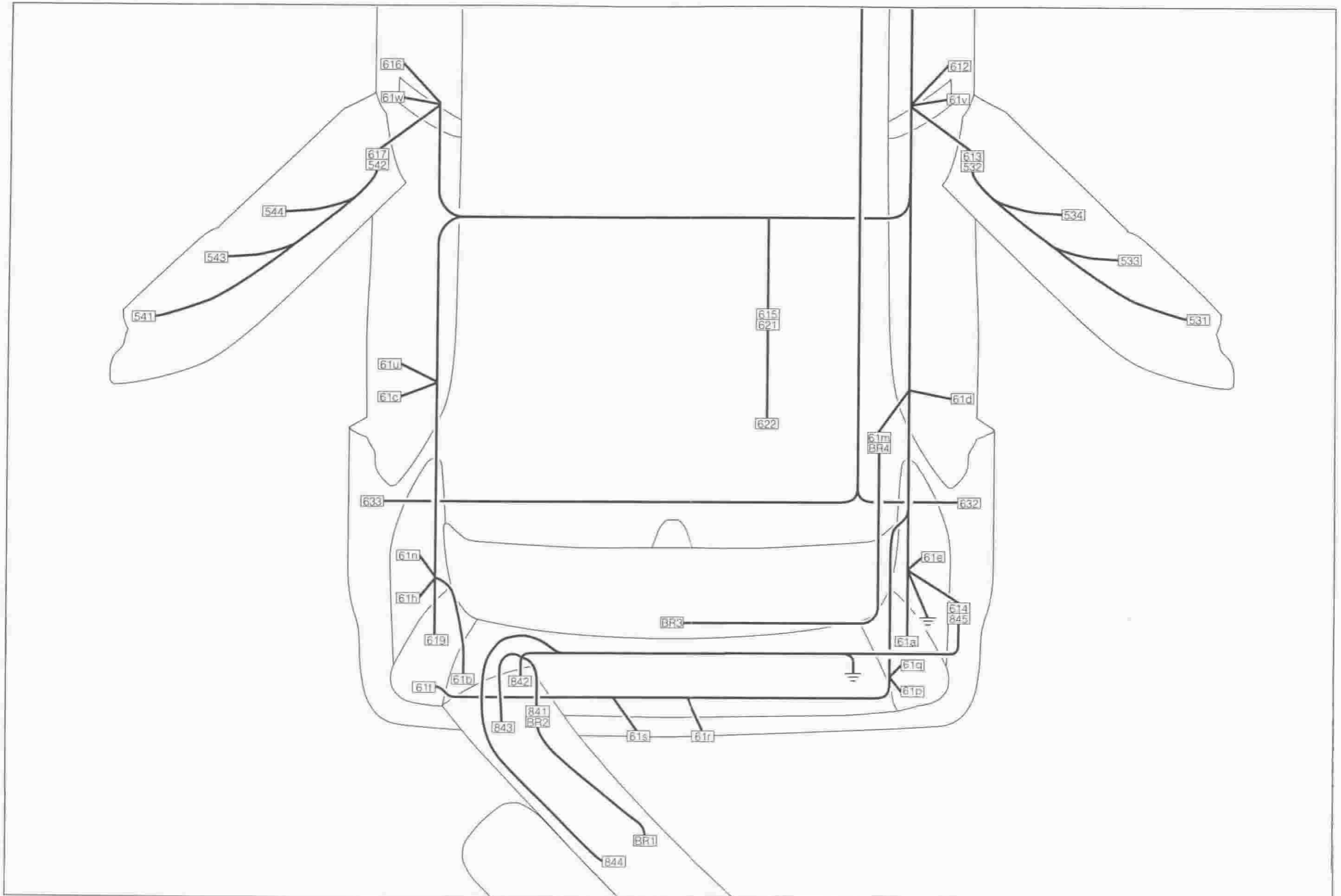

RHD vehicle

