

## SECTION 01

## 4ZD1 GASOLINE ENGINE

## INDEX

CONTENTS	PAGE
General description. ....	.01— 2
Main data and specifications. ....	.01— 4
Major parts fixing nuts and bolts. ....	.01— 7
Engine repair kit. ....	.01— 11
Engine assembly. ....	.01— 12
Removal and installation. ....	.01— 12
Disassembly. ....	.01— 15
Inspection and repair. ....	.01— 26
Reassembly. ....	.01— 46
Oil pump. ....	.01— 66
Water pump. ....	.01— 69
Radiator. ....	.01— 71
Thermostat. ....	.01— 73
Diagnosis. ....	.01— 75
Special tools. ....	.01—110

## GENERAL DESCRIPTION

### ENGINE

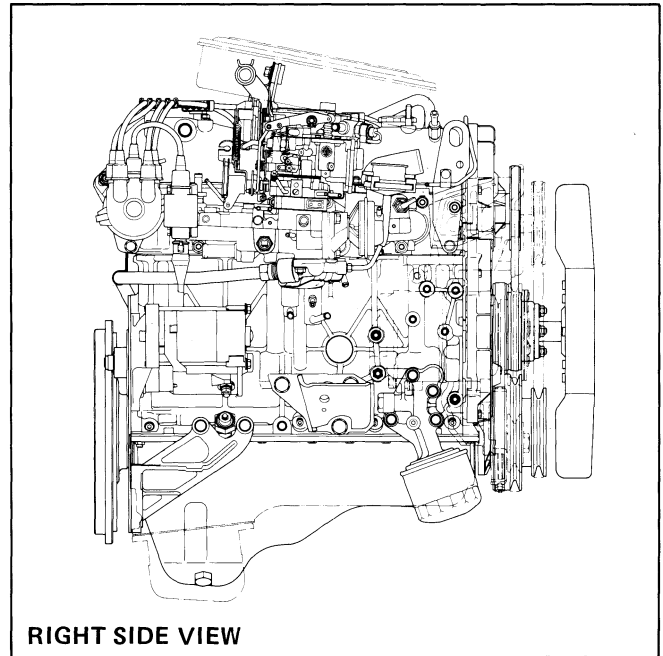
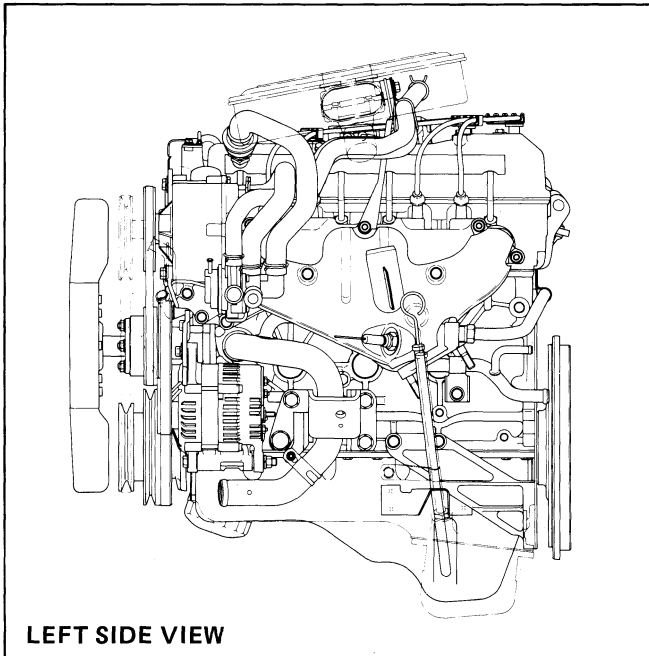
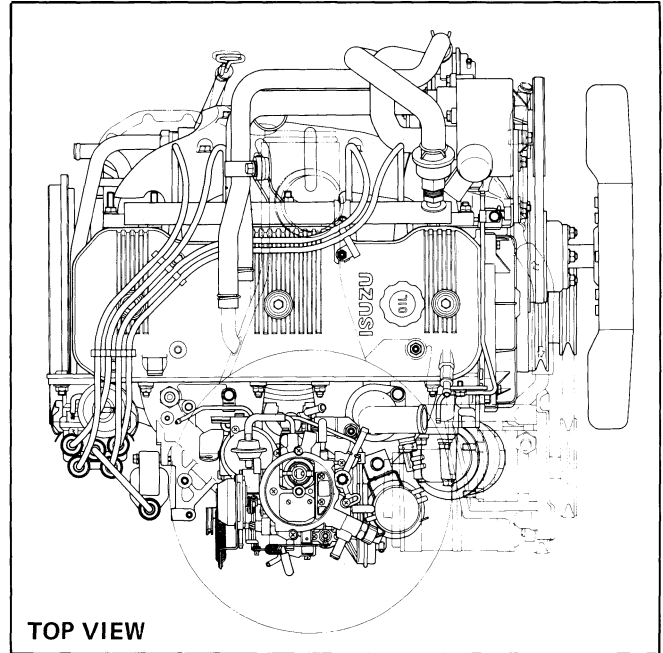
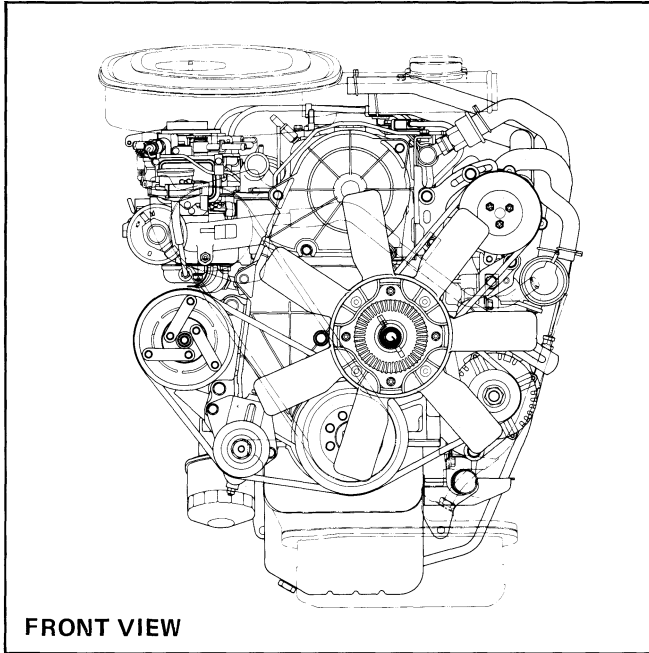

LUBRICATING SYSTEM

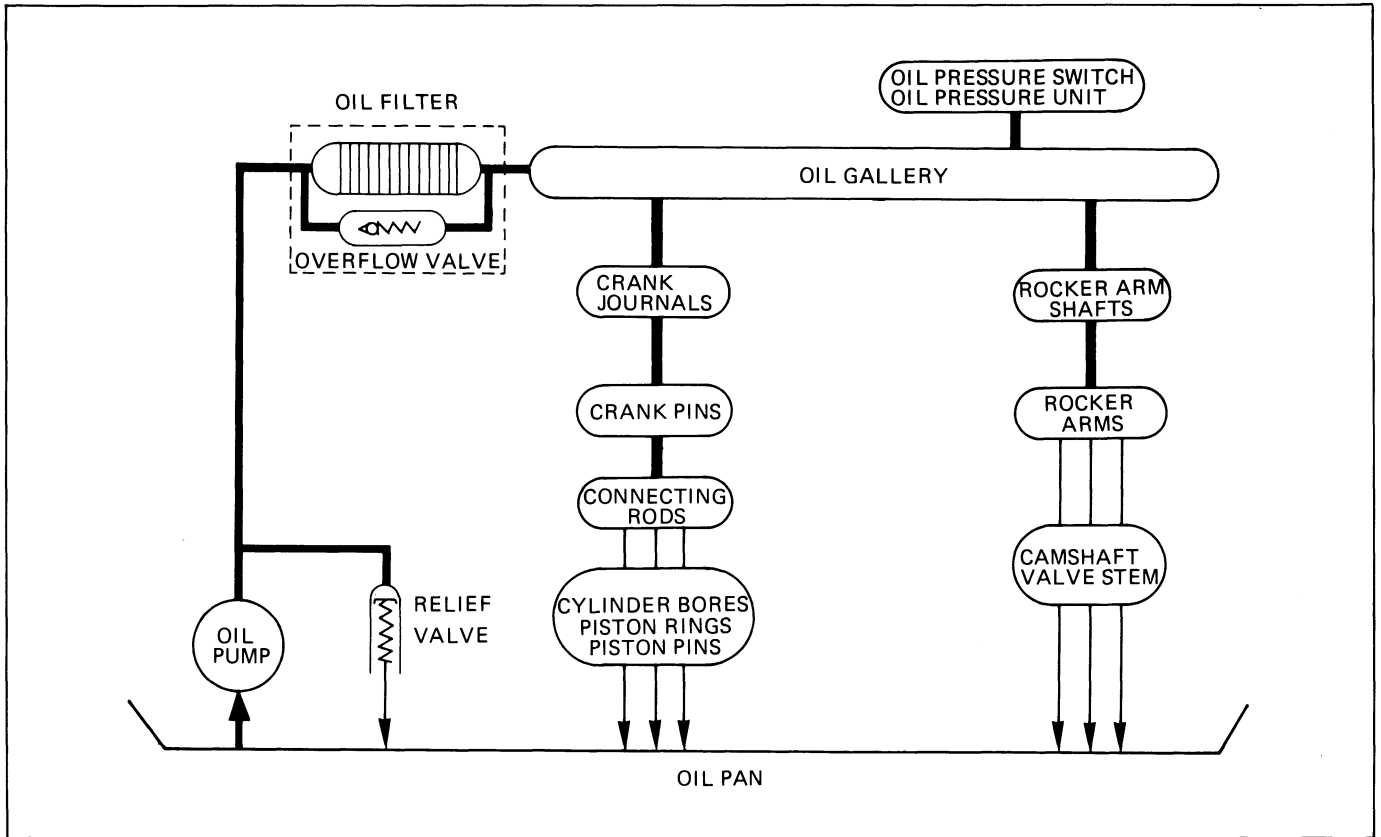

COOLING SYSTEM

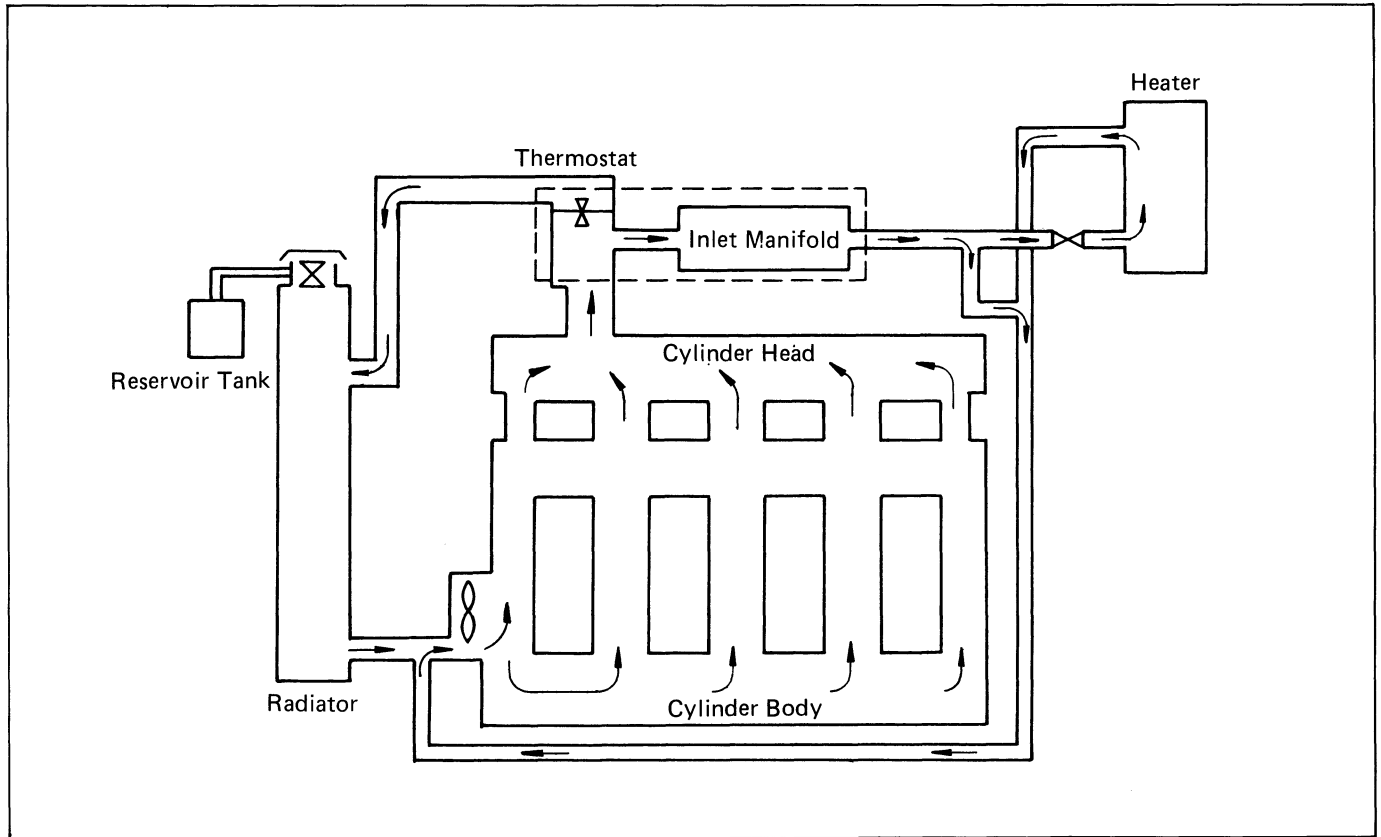

## MAIN DATA AND SPECIFICATIONS

Engine model Items	4ZD1
<b>ENGINE</b>	
Engine type	Gasoline, Water-cooled, 4-cycle cross-flow
Valve Mechanism	Single over-head camshaft (belt drive)
Combustion chamber type	Hemispherical type
No. of cylinders - Bore x Stroke	4 - 89.3 x 90 (3.52 x 3.54)
Piston displacement	2.25(138)
Compression ratio	8.3
Engine dimensions (length x width x height)	676 x 653 x 752 (26.63 x 25.72 x 29.62)
Engine weight: dry	148(326)
<b>PISTON</b>	
Type	Without T slot
Material	LO-EX
Number of rings (compression — Oil rings)	2 - 1
<b>VALVE SYSTEM</b>	
Intake valve	open at B.T.D.C. degree 21
	close at A.B.D.C. degree 65
Exhaust valve	open at B.B.D.C. degree 55
	close at A.T.D.C. degree 20
Valve clearance	Intake mm(in.) 0.15/0.20 (0.006/0.008)
Cold/Hot	Exhaust mm(in.) 0.25/0.30 (0.010/0.012)
Valve head diameter	Intake mm(in.) 42.4 (1.67)
	Exhaust mm(in.) 36.0 (1.42)
<b>IGNITION SYSTEM</b>	
Firing order	1-3-4-2
Ignition timing	B.T.D.C. degree/rpm 6/800 (Federal), 6/900 (California)
Distributor type	Full transistorized
Type of advance	Centrifugal and vacuum
Spark plugs	mm NGK BPR 6ES-11
Spark plug size	mm(in.) M14 P=1.25 (0.050)
Spark gap	mm(in.) 1.05 (0.040)



**01-6 4ZD1 GASOLINE ENGINE**

<b>Items</b>	<b>Engine model</b>	<b>4ZD1</b>
<b>CHARGING SYSTEM</b>		
Alternator type		Stator diode rectified alternator (4x4, LT1 50— 1 88) (4x2, LT150-187)
Voltage-capacity	<b>(V-AH)</b>	1 2 - 5 0
Drive and rotation		V-belt, clockwise viewed from front
Speed ratio to engine	<b>(to 1)</b>	2.14
Regulator type		IC Integrated in alternator
<b>STARTER MOTOR</b>		
Type		Magnet shift, reduction type
Voltage-Output	<b>(V-kW)</b>	1 2 - 1.0
Gear ratio		9:115

# MAJOR PARTS ; FIXING NUTS AND BOLTS

## CYLINDER HEAD, CYLINDER AND OIL PAN

kg-m(ft.lbs)

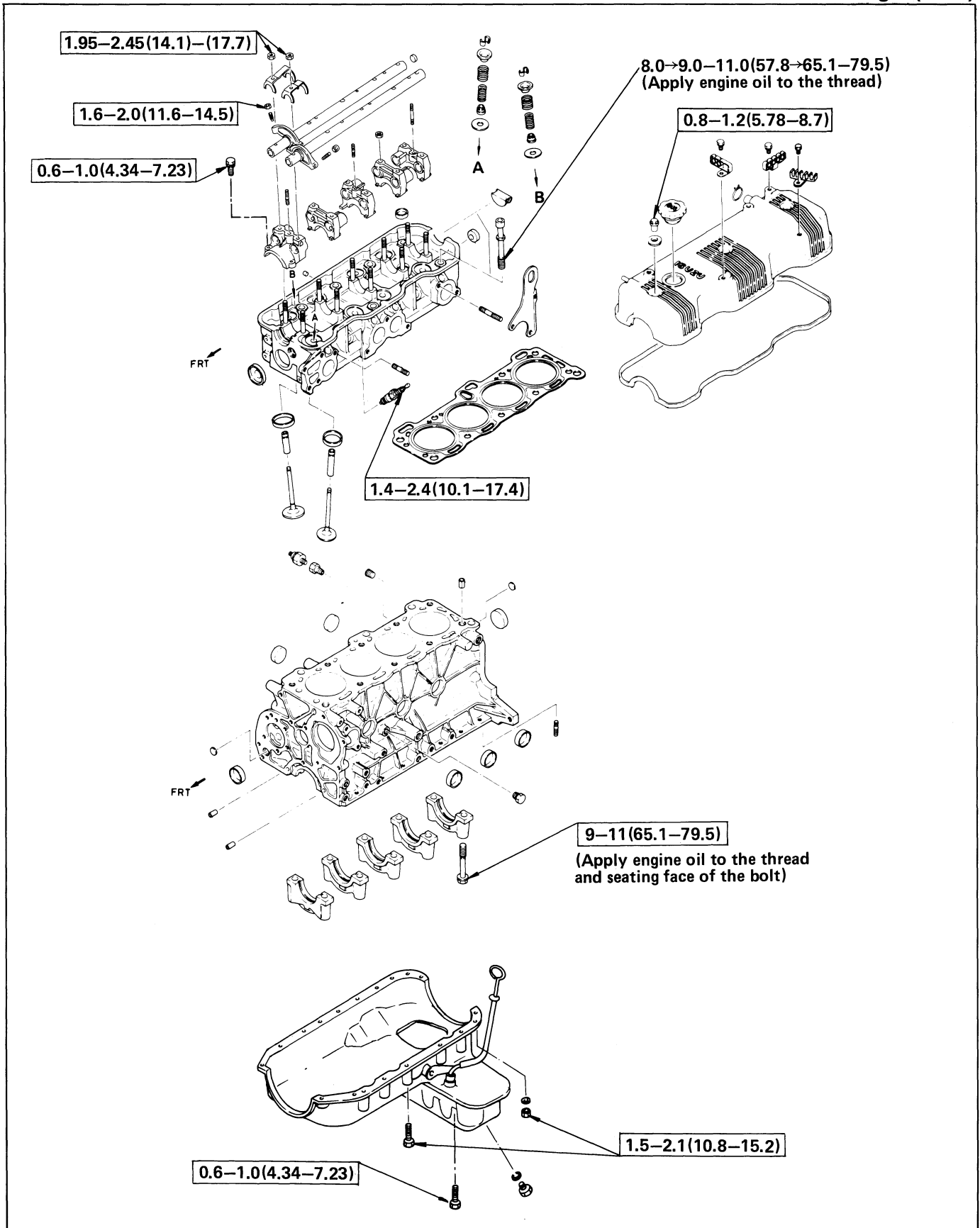

PISTON AND CRANKSHAFT

kg-m(ft.lbs)

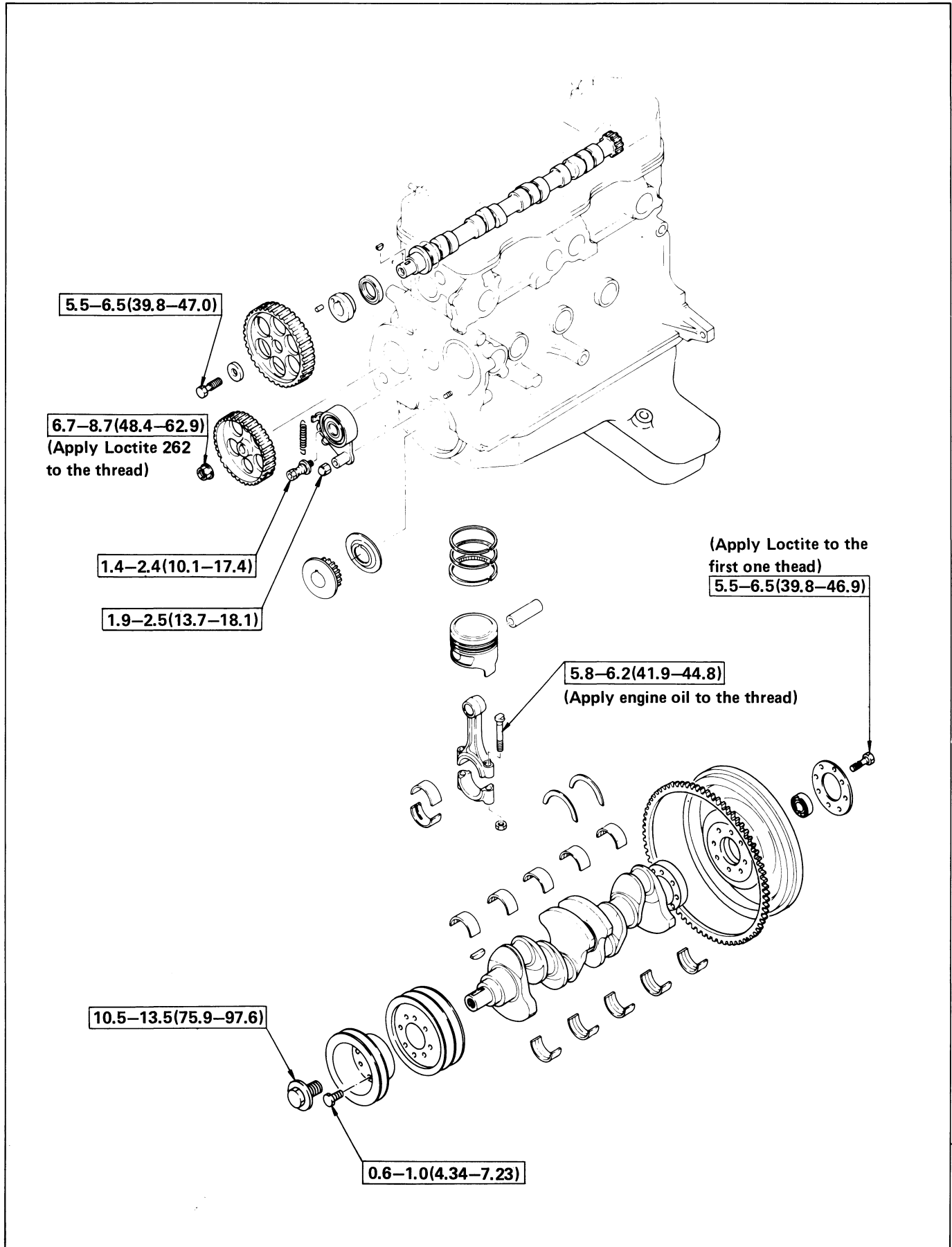



TIMING SPROCKET, GEAR CASE, WATER PUMP, FRONT COVER AND REAR COVER

kg-m(ft.lbs)

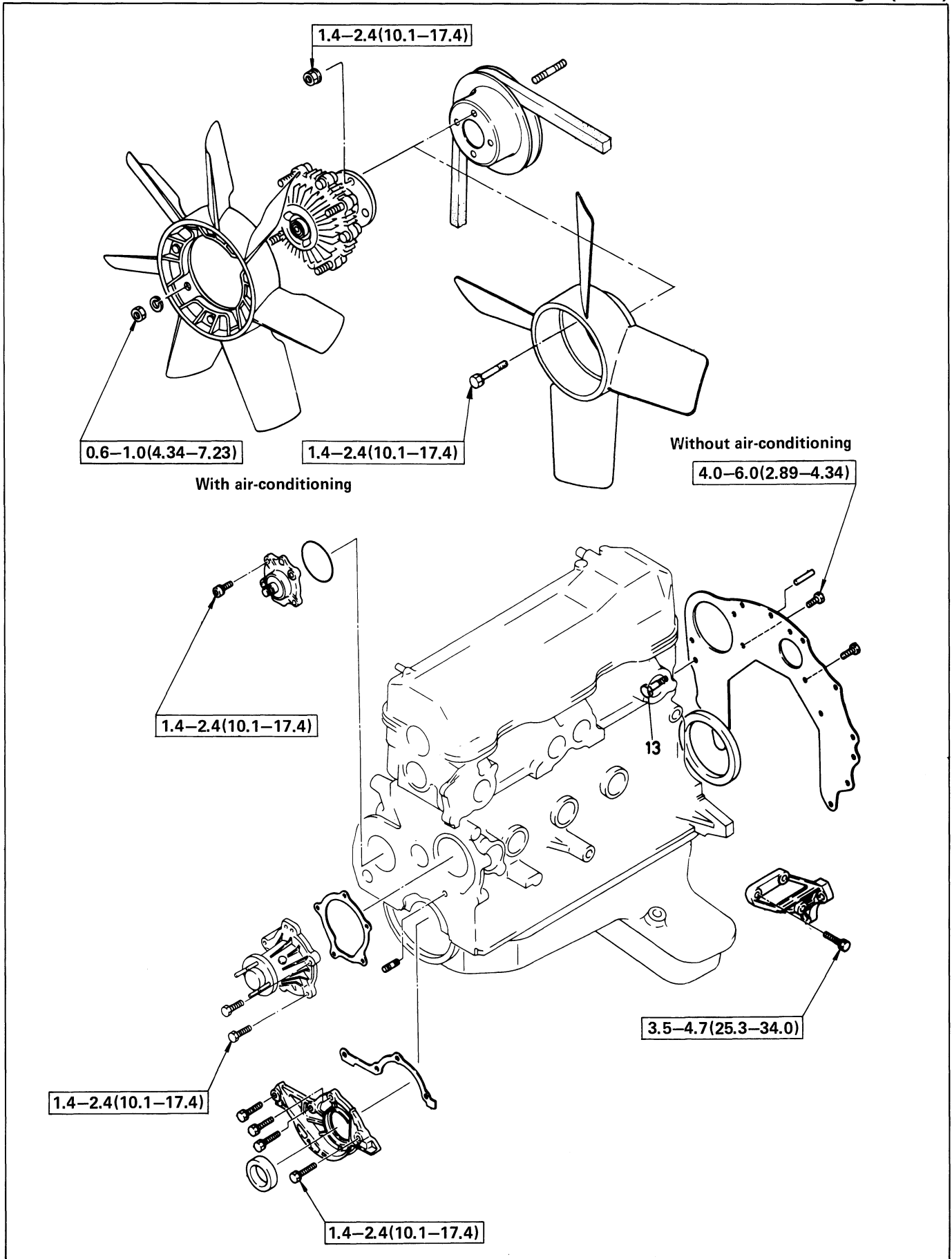

INTAKE MANIFOLD AND EXHAUST MANIFOLD

kg-m(ftlbs)

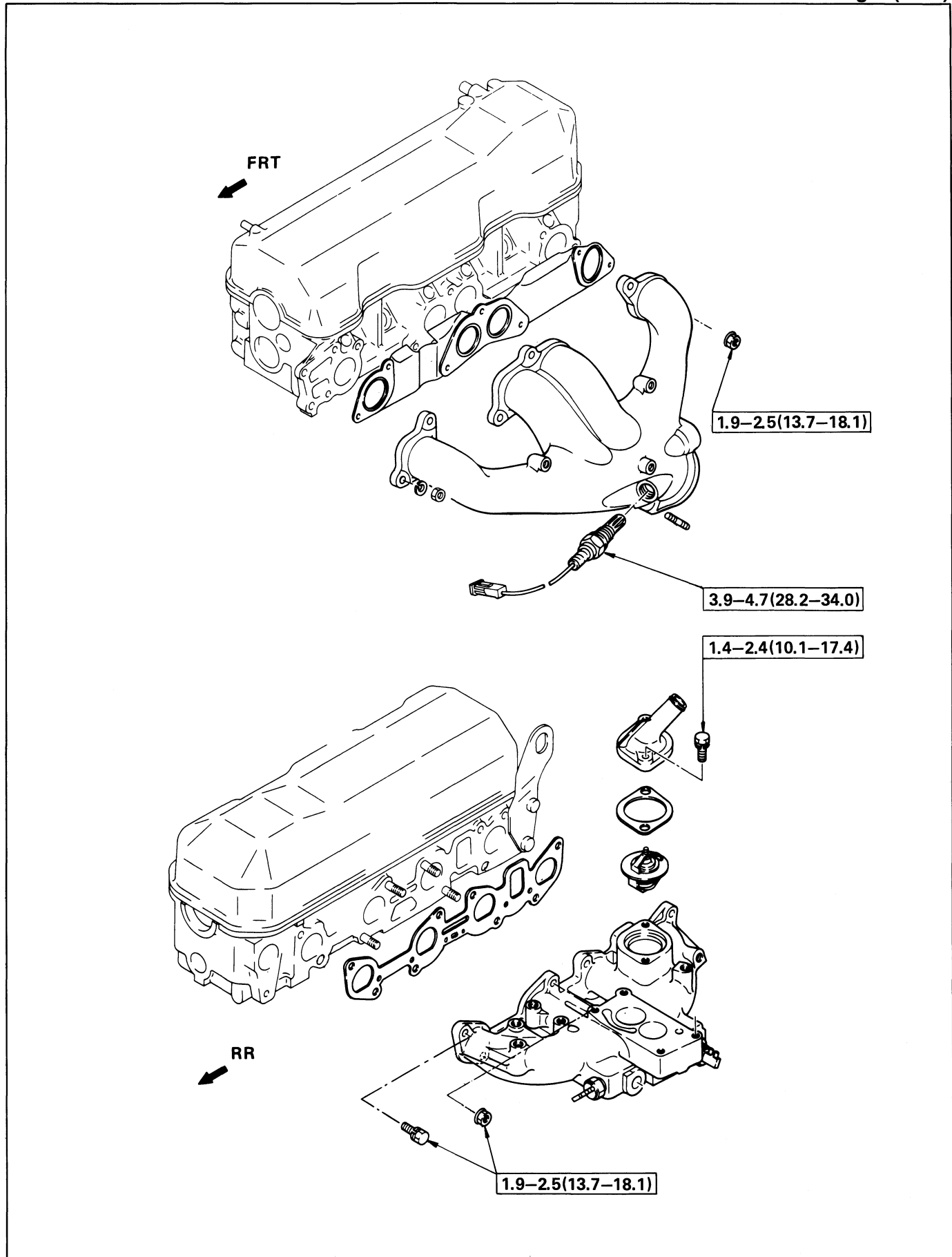

## ENGINE REPAIR KIT

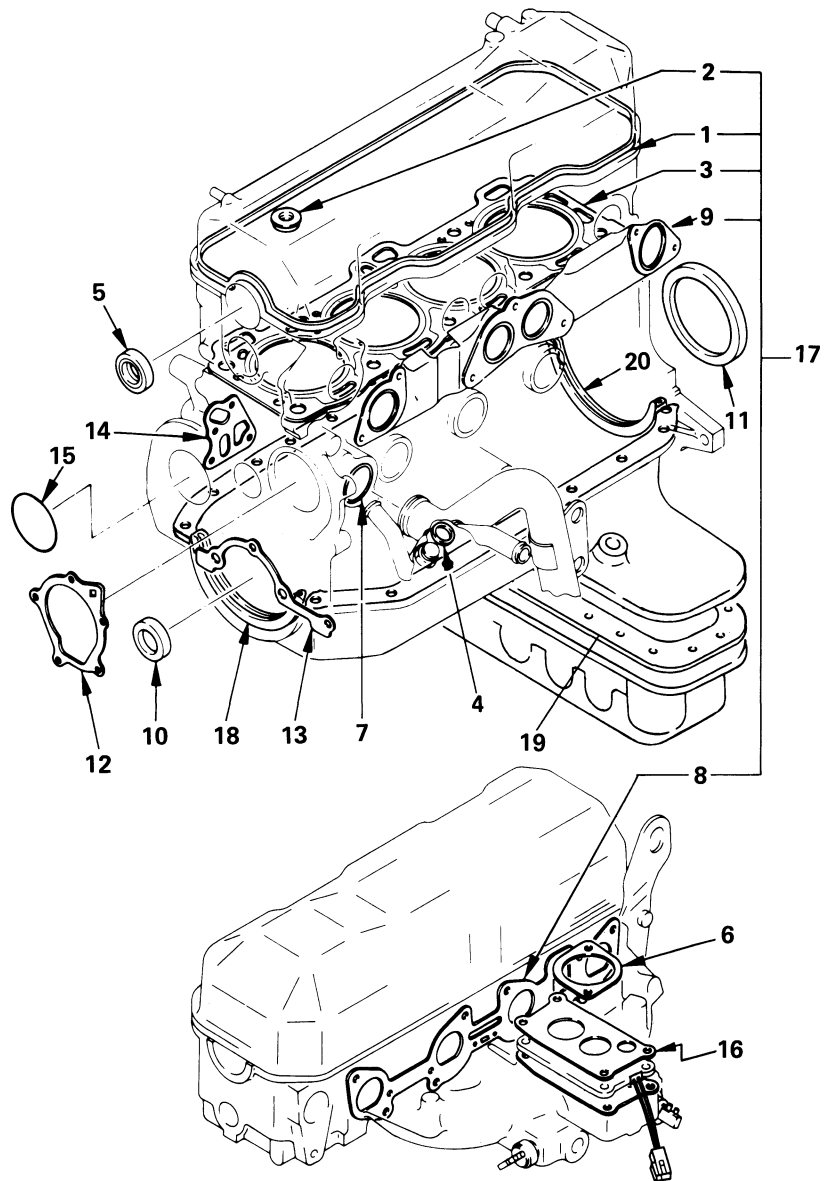

- |                                       |                               |
|---------------------------------------|-------------------------------|
| 1. Gasket; Cylinder head cover        | 11. Seal; Crankshaft rear     |
| 2. Gasket; Cap, head cover            | 12. Gasket; Water pump        |
| 3. Gasket; Cylinder head              | 13. Gasket; Retainer to block |
| 4. Gasket; Oil drain, oil pan         | 14. Gasket; Adapter to block  |
| 5. Seal; Oil camshaft frt.            | 15. Gasket; O-ring oil pump   |
| 6. Gasket; Outlet pipe to inl. manif. | 16. Gasket; Heat insulation   |
| 7. Gasket; O-ring, water pipe         | 17. Repair kit; Head overhaul |
| 8. Gasket; Inlet manifold             | 18. Gasket; Crank case, fit   |
| 9. Gasket; Exh. manifold              | 19. Gasket; Crank case, rear  |
| 10. Seal; Crankshaft front            | 20. Gasket; oil pan           |

## ENGINE ASSEMBLY

### REMOVAL AND INSTALLATION

#### REMOVAL

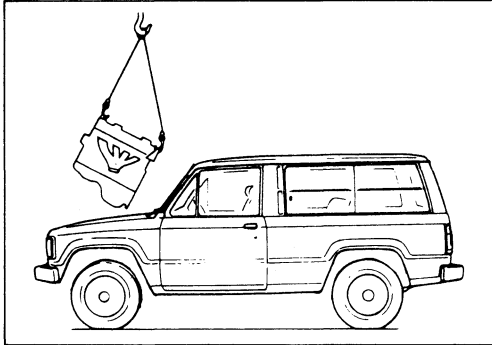

#### Removal steps

1. Remove battery cables.
2. Scribe position of the hinges on the engine hood, remove the four bolts attaching the hinges to the engine hood and remove the engine hood.
3. Remove the undercover and drain the cooling system by opening the drain plugs on the radiator and on the cylinder block.
4. Drain the engine oil.

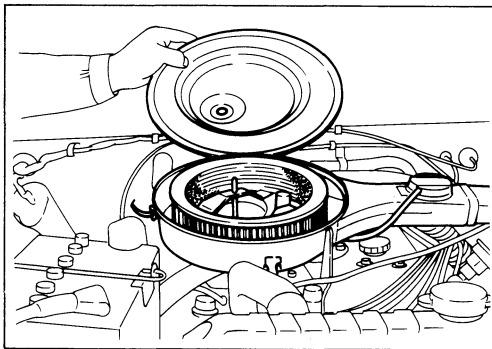

#### Removal air cleaner

1. Disconnect the PCV hose from the air cleaner body.
2. Disconnect the air hose from the AIR pump.
3. Remove the air duct from air cleaner.
4. Remove the bolts attaching the air cleaner and remove the wing nut attaching the air cleaner.
5. Lift the air cleaner slightly and disconnect the TCA hose (from thermosensor and hot idle compensator to intake manifold), then remove the air cleaner assembly.

#### Removal of parts at left side of engine

1. Disconnect the TCA hot air hose and remove the manifold cover.
2. Disconnect the generator wiring at the connector.
3. Remove the two nuts connecting the exhaust pipe to the engine exhaust manifold, and disconnect the exhaust pipe.
4. Take the tension off of the clutch control cable by loosening the adjusting nut.
5. Disconnect the heater hoses at heater core tubes.
6. Disconnect the oxygen sensor wiring at the connector. (California only).
7. Disconnect the rubber hose at air switching valve and vacuum switching valve (California only).
8. Remove the engine mounting nut.

**Removal of parts at right side of engine**

1. Disconnect the cable grounding the cylinder block to the frame.
2. Disconnect the fuel hoses from the carburetor.
3. Pull out the high-tension cable from the ignition coil.
4. Disconnect the vacuum hose from the connector at the rear part of the intake manifold.
5. Disconnect rubber hoses at canister.
6. Disconnect the accelerator control cable from the carburetor.
7. Disconnect the starter motor connections.
8. Disconnect the thermo-unit, oil pressure switch and distributor wiring at the connector.
9. Disconnect rubber hose at vacuum switch (California only).
10. Disconnect the thermo switch wiring at the connector.
11. Disconnect the ground wiring at the connector on the rear part of intake manifold. (California only).
12. Disconnect the EFE heater wiring at the connector.
13. Disconnect the carburetor solenoid valve lead and automatic choke wiring at the connector.
14. Disconnect the back-up light switch and transmission switch wiring at the connector on the rear part of the engine.
15. Remove the engine mounting nut.
16. Raise the engine slightly and remove the left side engine mounting stopper plate.

**Removal of parts at front of engine**

**NOTICE:** Remove the transmission from the engine before engine removal from vehicle (4x4 only). Refer to "Transfer case replacement procedure" section 05B of this manual.

1. Disconnect compressor flex hoses (If equipped).
2. Disconnect the radiator reserve tank pipe at the radiator side.
3. Disconnect the radiator upper and lower hoses from the outlet pipe and from the radiator, respectively.
4. Remove the radiator attaching bolts, and remove radiator.
5. Remove fan blade assembly.

**Removal of interior parts**

1. Take out the gearshift lever assembly.

**Removal of parts under the floor**

1. Remove the parking brake return spring and disconnect brake cable.
2. Disconnect the propeller shaft from the transmission. (Refer to "Propeller shaft replacement procedure" section 07 & 07A of this manual.)
3. Remove the clutch return spring.
4. Disconnect the clutch control cable from the clutch lever and remove it from engine stiffener.
5. Remove the front side exhaust pipe bracket from the transmission.

## 01-14 4ZD1 GASOLINE ENGINE

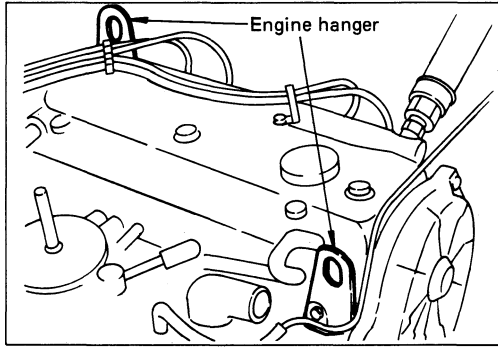

6. Disconnect the mounting clamp of front side exhaust pipe.
7. Disconnect the speedometer cable.
8. Remove the rear speedometer cable.

**NOTICE:** Check that the engine is slightly lifted before removing the rear engine mounting bolts.

### Engine removal

1. Check to make certain all the parts have been removed or disconnected from the engine.
2. Raise the engine toward front of the vehicle.
3. Remove the transmission assembly from the engine.

## INSTALLATION

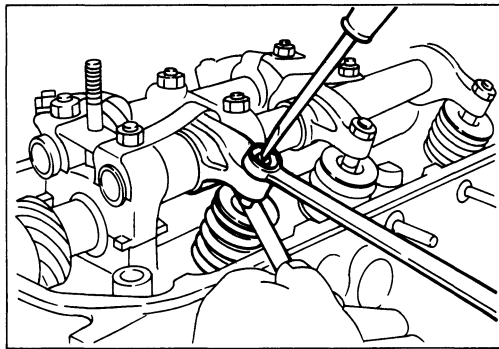

### Installation steps

To install the engine in the vehicle, reverse the removal procedure.

### Preparation for engine installation

1. Check harnesses for damage and correct or replace with new ones as necessary.
2. Check the engine mounting rubbers for looseness or damage and tighten or replace with new ones as necessary.



### Steps to be followed after engine installation

1. Fill the engine cooling system.
2. Fill the engine crankcase with engine oil.
3. Check and adjust clutch pedal free play as necessary.
4. Start and let the engine run at idle and check for leakage.
5. Adjust the following.
  - a. Check and adjust fan belt tension as necessary.
  - b. Adjust valve clearances.
  - c. Adjust ignition timing.
  - d. Adjust engine idle.



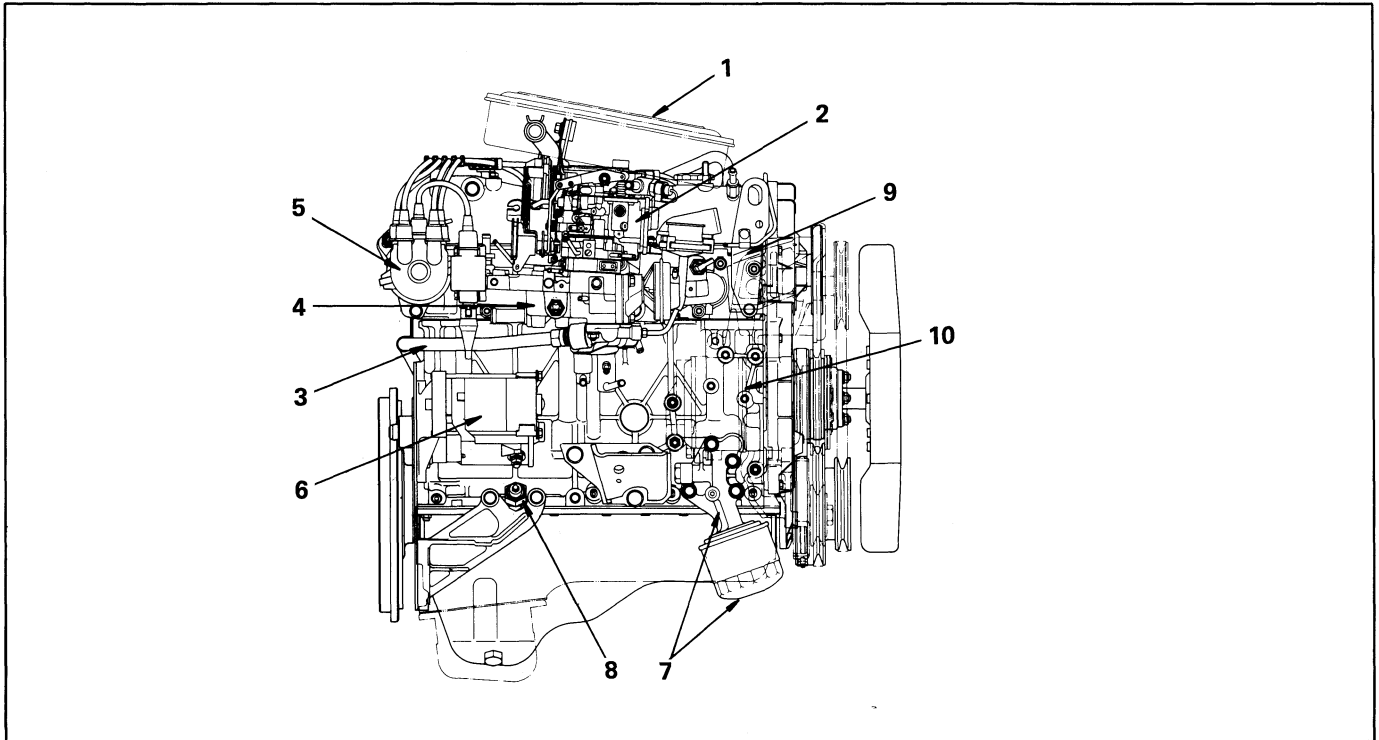

**DISASSEMBLY**
**EXTERNAL PARTS (Right hand side)****Disassembly steps**

- |                         |  |
|-------------------------|--|
| 1. Air cleaner assembly | 6. Starter motor assembly                        |
| 2. Carburetor assembly  | 7. Oil filter and unit                           |
| 3. EGR pipe             | 8. Oil pressure switch                           |
| 4. Inlet manifold       | 9. Power steering pump and bracket               |
| 5. Distributor assembly | 10. Air conditioning compressor (If so equipped) |

## 01-16 4ZD1 GASOLINE ENGINE

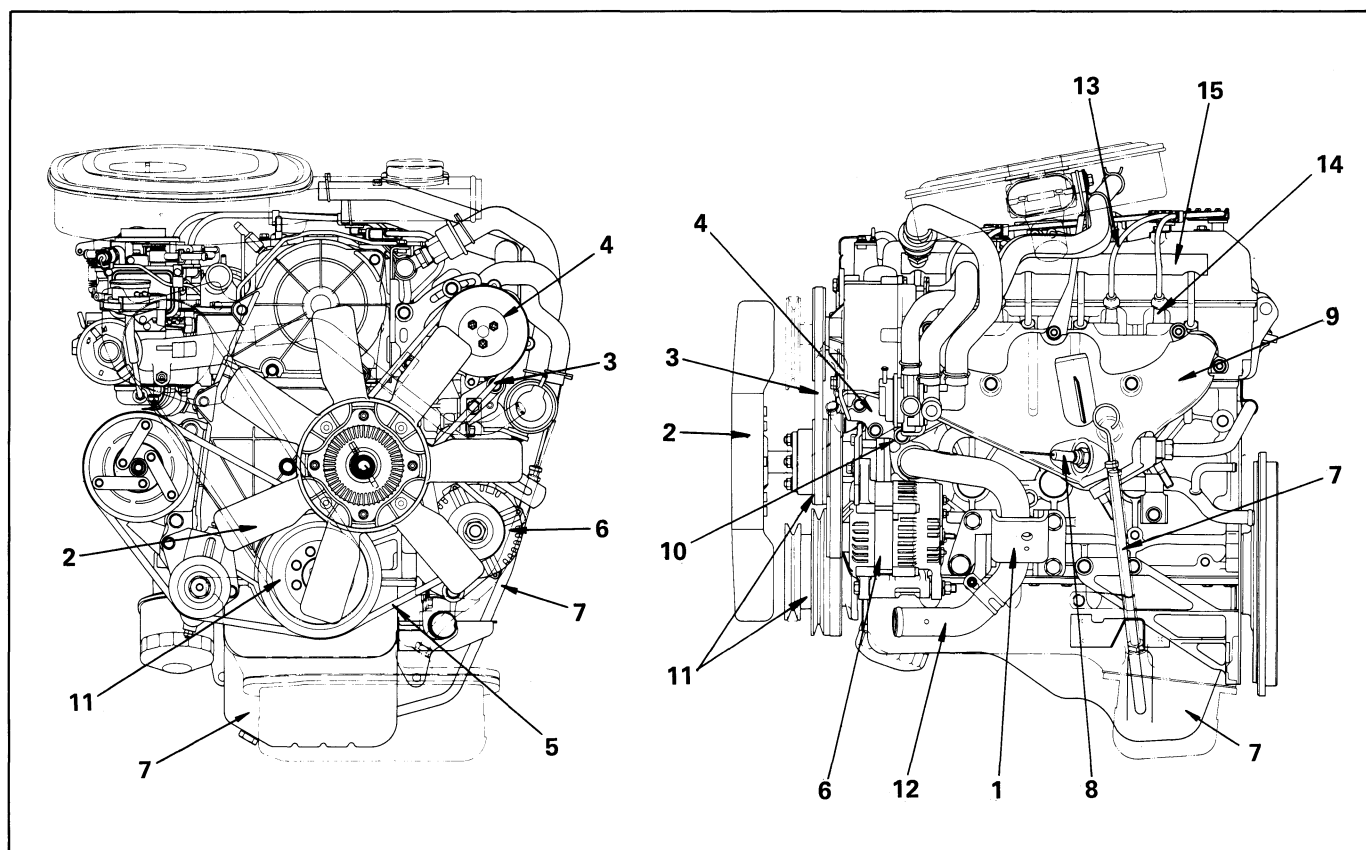
### EXTERNAL PARTS (Front and left hand side)



#### Disassembly steps

1. Engine mounting bracket
  2. Fan and clutch assembly
  3. V-belt; air pump
  4. Air pump and bracket "B"
  5. V-belt; alternator
  6. Generator and bracket
  7. Oil pan and oil level gauge
  8. O<sub>2</sub> sensor (California only)
  9. Exhaust manifold
  10. Air pump bracket "A"
  11. Crankshaft pulley and water pump pulley
  12. Water inlet pipe
  13. High-tension cord
  14. Spark plug
  15. Air injection manifold
- \* Installation engine assembly to engine stand, then remove the engine hanger.



MAJOR COMPONENTS (1)

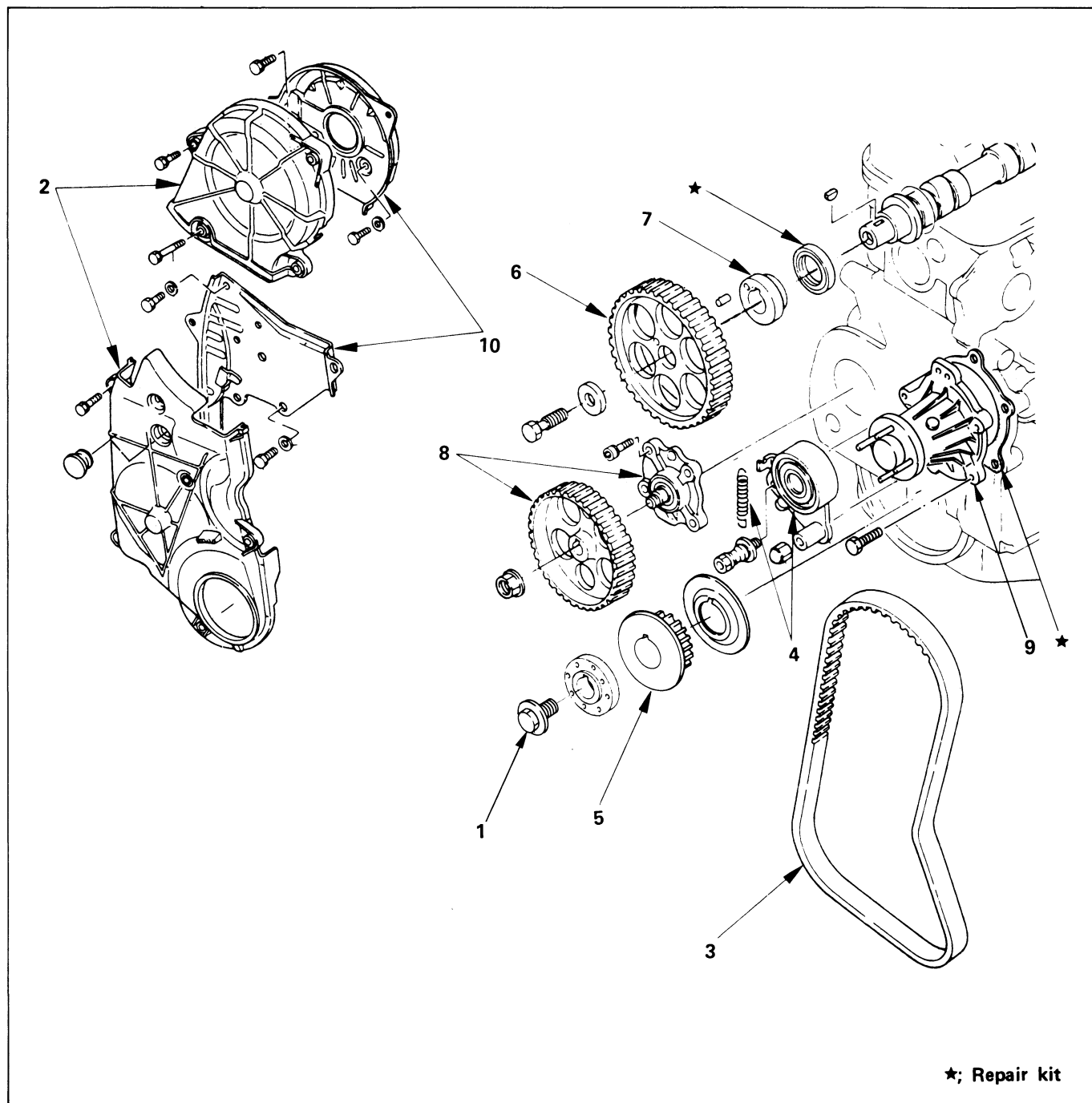

★; Repair kit

Disassembly steps

- |  |                             |
|--|-----------------------------|
| 1. Crankshaft pulley bolt              | A 6. Camshaft timing pulley |
| 2. Timing belt cover                   | 7. Camshaft boss            |
| A 3. Timing belt                       | A 8. Oil pump and pulley    |
| A 4. Tension pulley and tension spring | 9. Water pump               |
| 5. Crankshaft timing pulley            | 10. Front plate             |



### Important operations

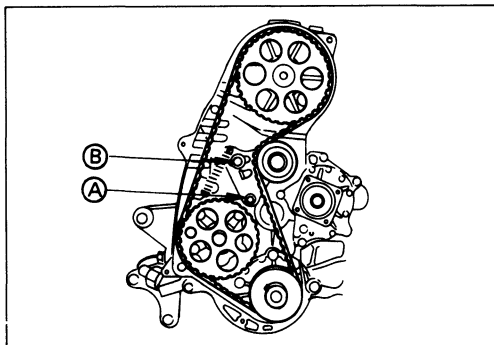

#### 3. Timing belt

#### 4. Tension pulley and tension spring

- (1) Remove the tension spring.
- (2) Loosen bolt (§), draw the tension pulley fully to the water pump side.
- (3) Remove the timing belt.
- (4) Remove the tension pulley and tension spring.
- (5) Remove the crank timing pulley and guide plate.

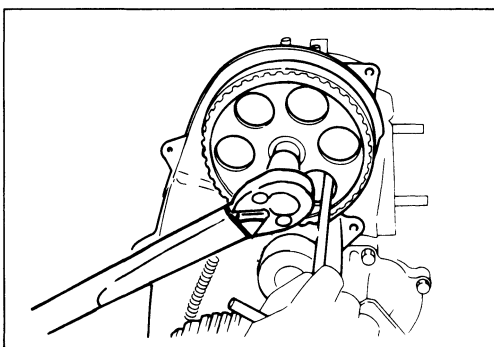

#### 6. Camshaft timing pulley

Apply a detent to the pulley by putting a T-bar wrench or other proper tool over the front-plate fitting bolt and loosen the pulley fitting bolts.

**Note:** The timing belt must be off (removed from) the camshaft timing pulley during both removal and installation of the camshaft timing pulley.

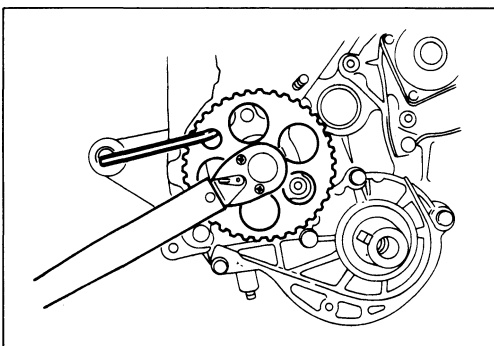

#### 8. Oil pump and pulley

Apply a detent with an inner hex, and loosen the oil pump pulley bolt and remove the pulley.

Wrench; inner hex = 6 mm

MAJOR COMPONENTS (2)

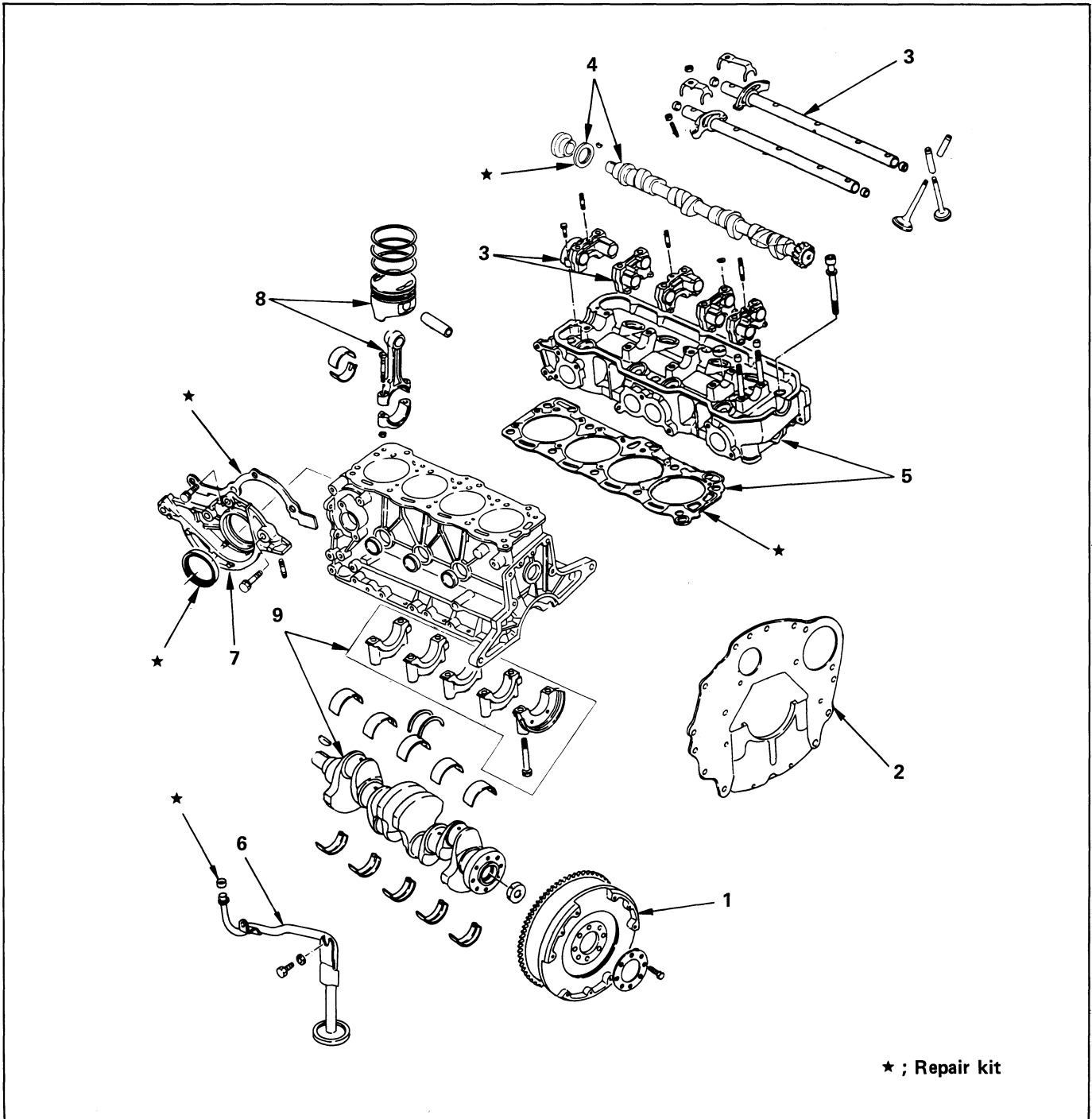

**Disassembly steps**

- |  |  |
|--|--|
| <ul style="list-style-type: none"> <li>A 1. Flywheel</li> <li>A 2. Rear plate</li> <li>A 3. Rocker arm bracket and shaft</li> <li>A 4. Camshaft and oil seal</li> <li>A 5. Cylinder head and gasket</li> </ul> | <ul style="list-style-type: none"> <li>A 6. Oil pipe assembly</li> <li>A 7. Front oil seal retainer</li> <li>A 8. Piston and connecting-rod</li> <li>A 9. Crankshaft and bearing caps</li> </ul> |
|--|--|



**Important operations**

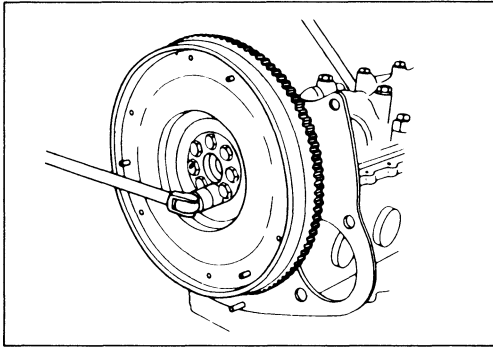

**1. Flywheel**

Hold the crankshaft from turning using wooden bar and remove the flywheel mounting bolts.

Remove the flywheel by tapping on it with a plastic hammer. Flywheel is a heavy mass and should be handled carefully so as not to drop it.

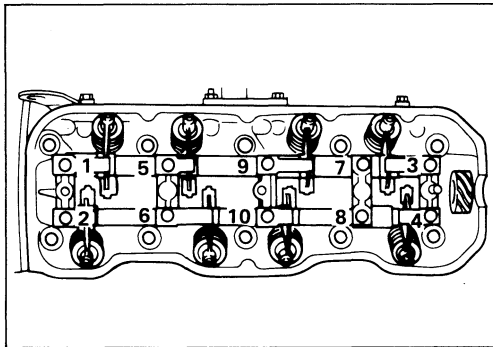

**3. Rocker arm bracket and shaft**

Sequentially loosen and remove the rocker arm shaft tightening nuts from the outermost one, and remove the rocker arm shaft with the bracket as an assembly.

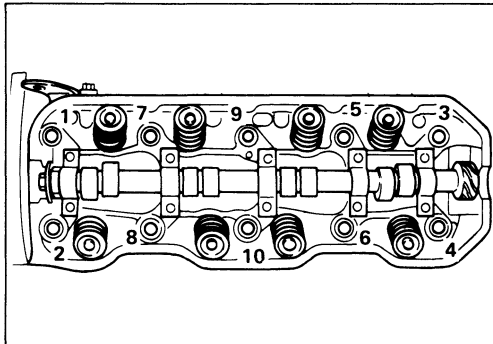

**5. Cylinder head and gasket**

Loosen the head bolts evenly from the outermost one using an extension bar wrench and thereby remove the cylinder head. Remove also the gasket at this time.

Wrench ; inner hex = 10 mm

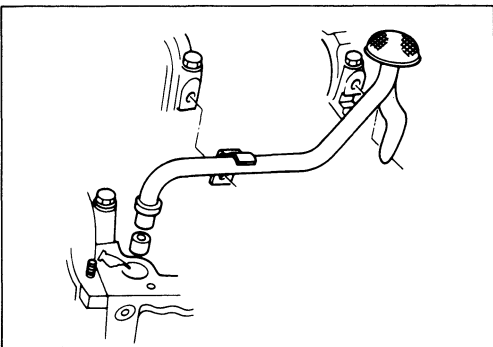

**6. Oil pipe assembly**

Remove the oil pipe assembly fitting bolts and draw the pipe out from the cylinder block.

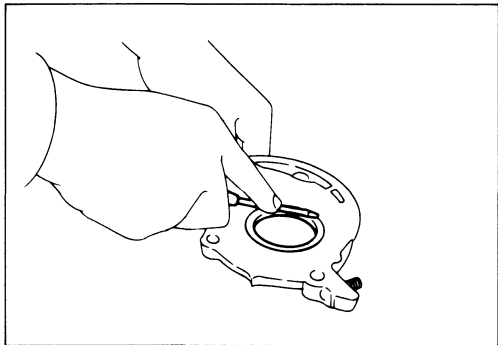

**7. Front oil seal retainer**

Front oil seal replacement.  
Remove the front oil seal with driver.

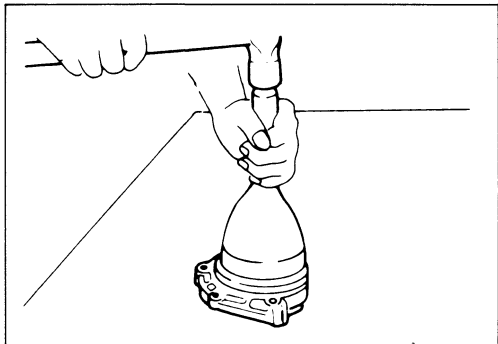

**Attach the oil seal using a special tool**

Front oil seal installer : J-26587

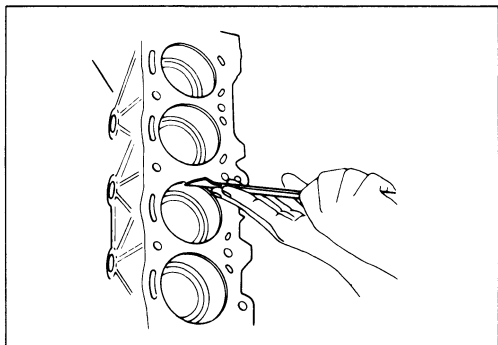

**8. Piston and connecting-rod**

(1) Remove carbon adhering to the upper section of the cylinder bore.

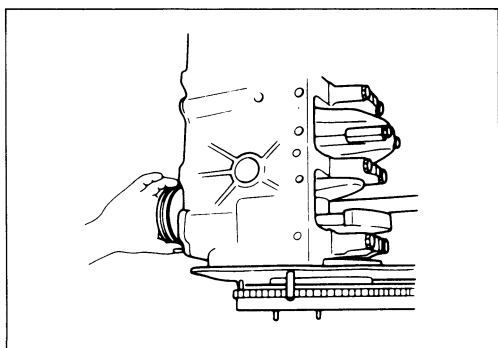

(2) Draw out the piston while pushing the end of the connecting-rod.

(3) Remove the connecting-rod bearing.

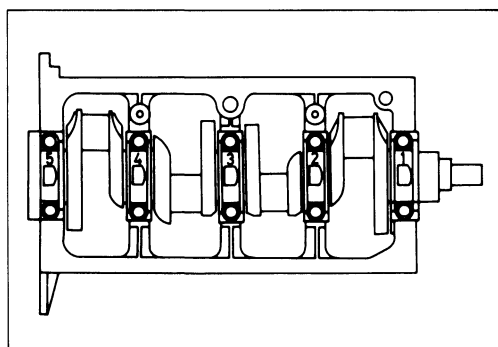

**9. Crankshaft and bearing caps**

Loosen and remove the crankshaft bearing caps in the order indicated in the figure.

Remove the crankshaft.

MINOR COMPONENTS

PISTON AND CONNECTING-ROD ASSEMBLY

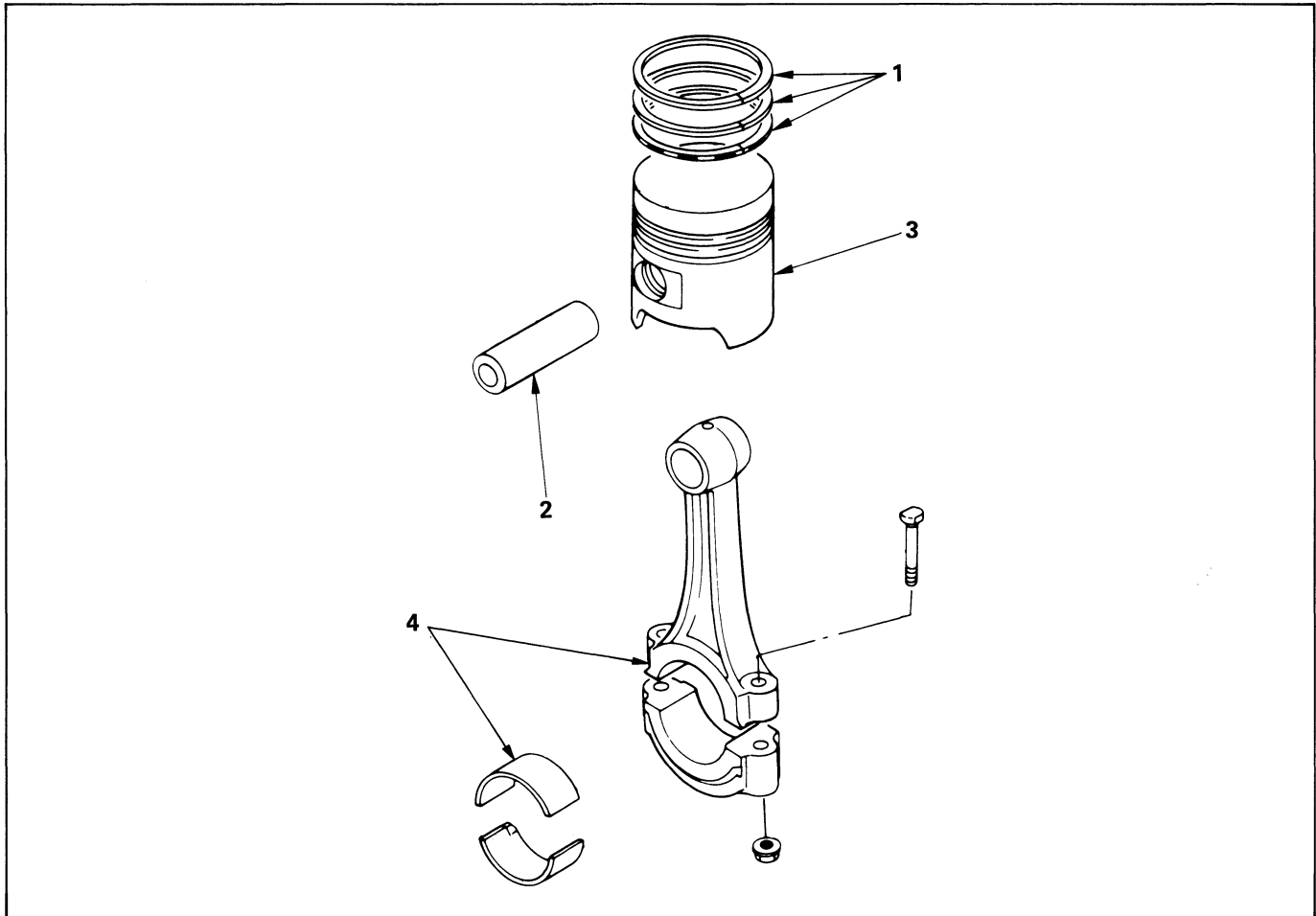

**Disassembly steps**

- A 1. Piston rings
- A 2. Piston pin

- 3. Piston
- 4. Connecting-rod with bearing



**Important operations**



**1. Piston rings**

Remove the piston rings with a piston ring expander.

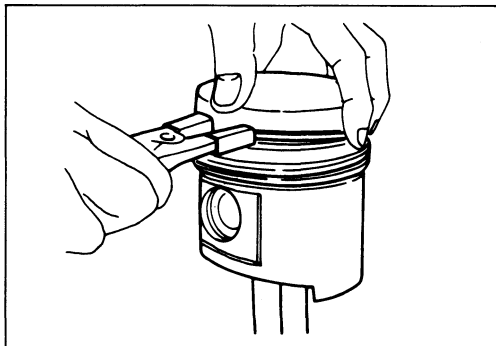

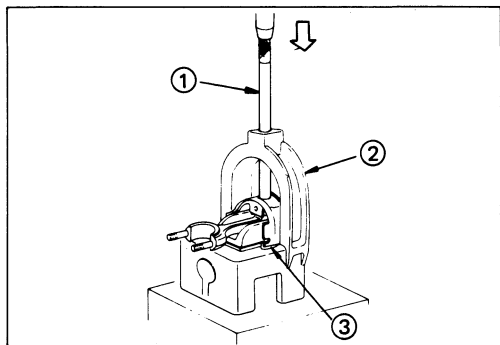

## 2. Piston pin

Remove the piston pin using a piston pin service set piston support with a press.

Remover and installer : J-24086

- 1. Remover : J-24086-8
- 2. Bass fixture : J-24086-8
- 3. Piston support : J-24086-75

ROCKER ARM SHAFT

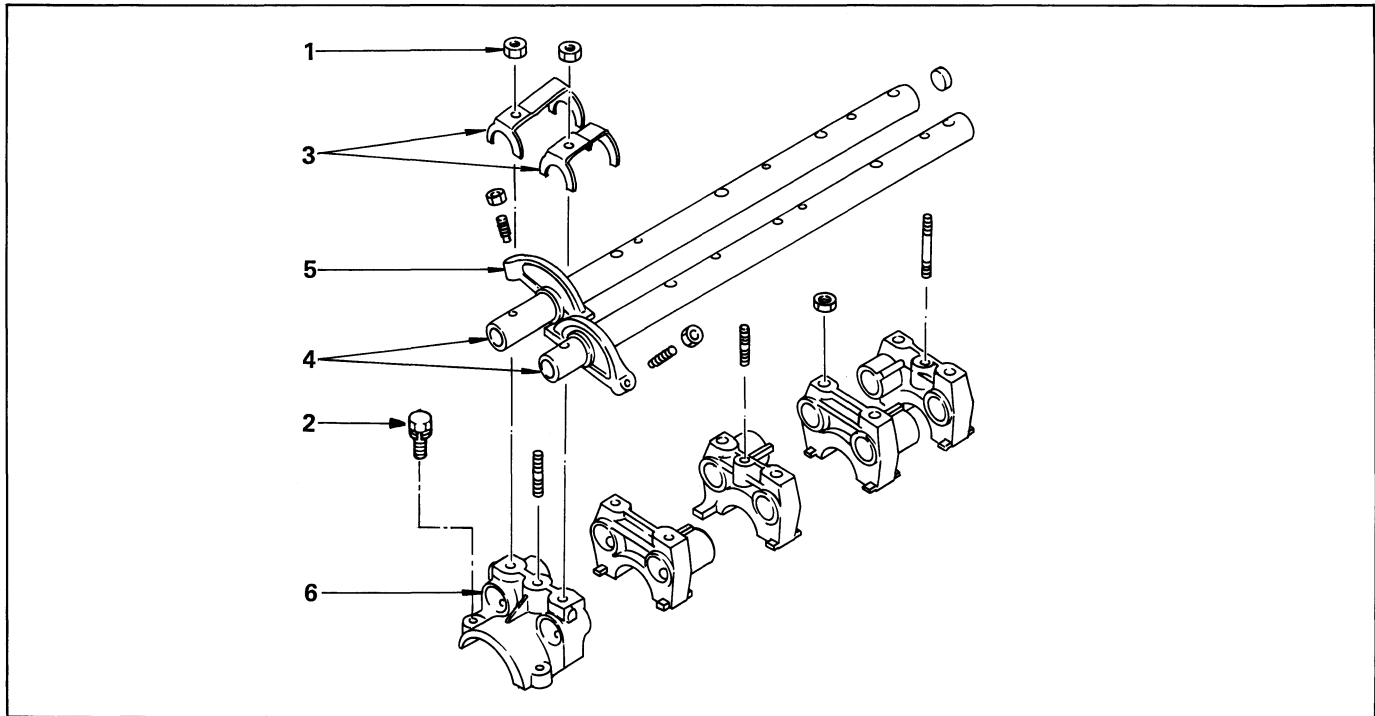

Disassembly steps

- |                             |                              |
|-----------------------------|------------------------------|
| 1. Nut; rocker arm bracket  | 4. Shaft; rocker arm         |
| 2. Bolt; rocker arm bracket | 5. Rocker arm                |
| 3. Spring ; rocker arm      | 6. Bracket; rocker arm shaft |



CYLINDER HEAD

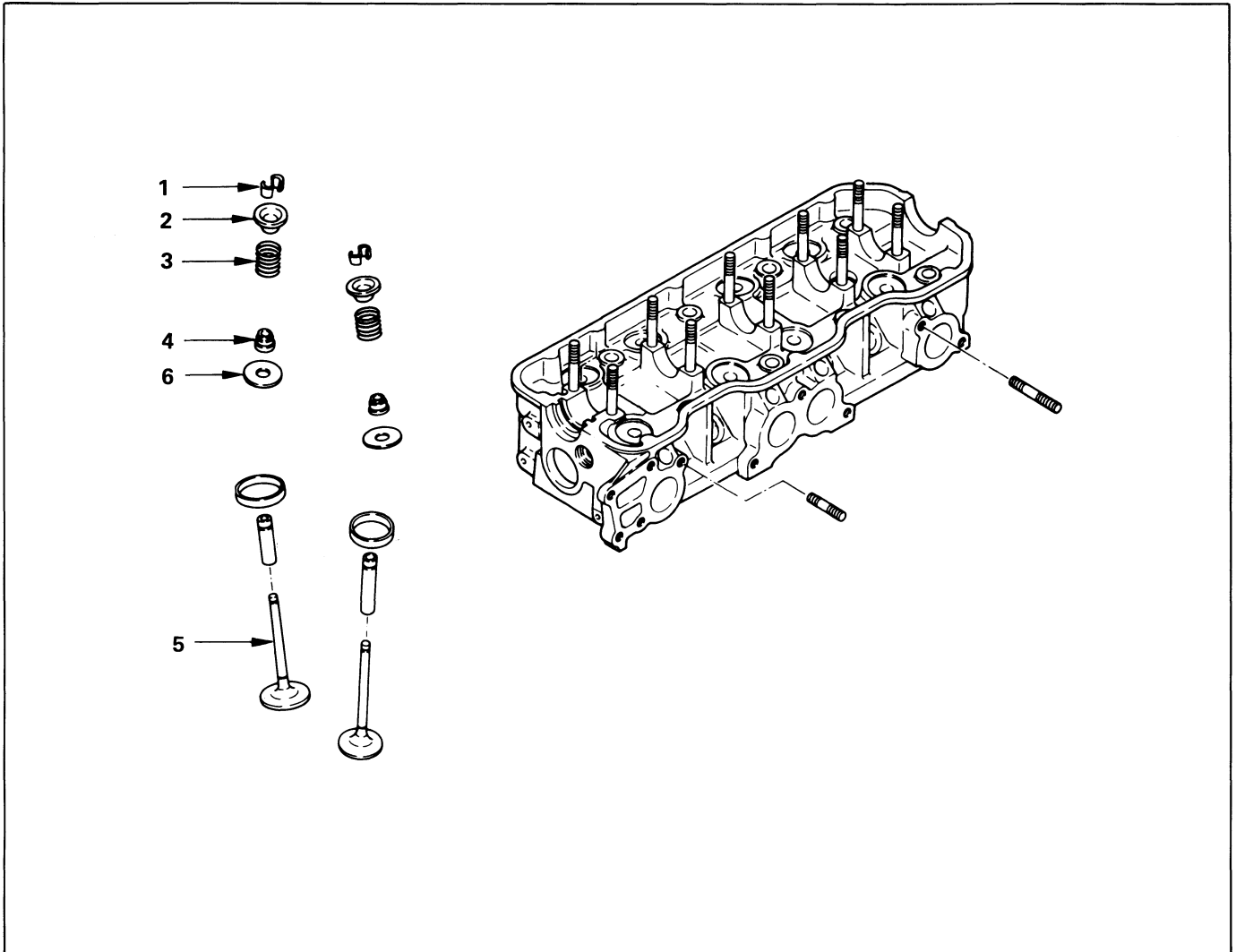

**Disassembly steps**

- 1. Split collar
- 2. Upper spring seat
- 3. Valve spring
- 4. Oil controller
- 5. Valve
- 6. Lower spring seat



**Important operations**



**1. Split collars**

Compress the spring with valve spring compressor and remove the split collars.

When compressing the spring, push the valve up by your hand.  
Valve spring compressor : J-26513-A

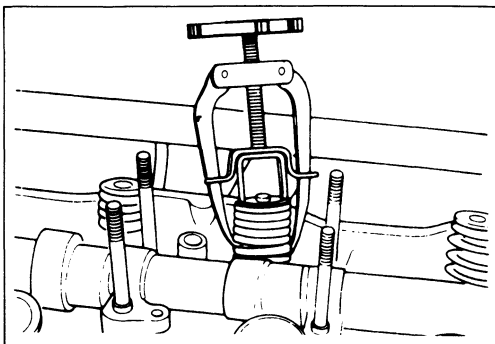

# **INSPECTION AND REPAIR**

Make necessary correction or parts replacement if wear, damage or any other abnormal condition are found through inspection.

**Note:** Wash and clean each parts detected to remove all dirt, carbon, contaminated oil, rust, fur and other foreign matters. Ample care should be taken to avoid damage when removing carbon adhering to the piston, cylinder head, valve, and other parts. Employ compressed air to remove foreign matters in the oil hole of each parts, and confirm there is no choking.

## CYLINDER HEAD

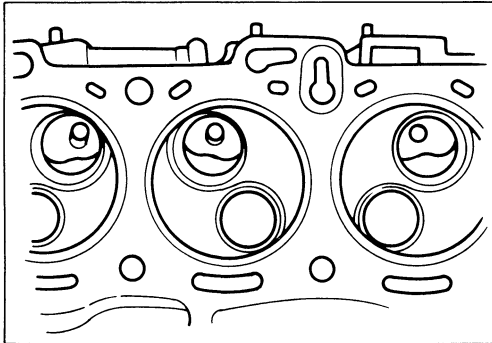

### Visual check

Remove carbon adhering to the lower face while taking care not to damage the valve seat and other parts, and check for cracks and damage.

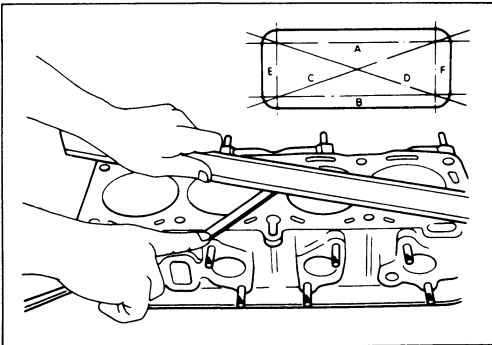

### Distortion of lower face

Make six measurements on the four sides and the diagonals, and if the limit is exceeded make necessary correction or replacement.

mm (in.)		
Standard	Limit	Maximum repairable limit
0.05(0.003) or less	0.2(0.008)	0.4(0.016)

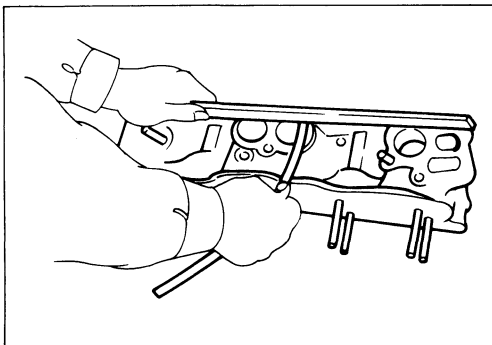

### Distortion of manifold face

Make measurement in a manner similar to that for the cylinder head. If the limit is exceeded make necessary correction.

mm(in.)	
Standard	Limit
0.05 (0.002) or less	0.4 (0.016)

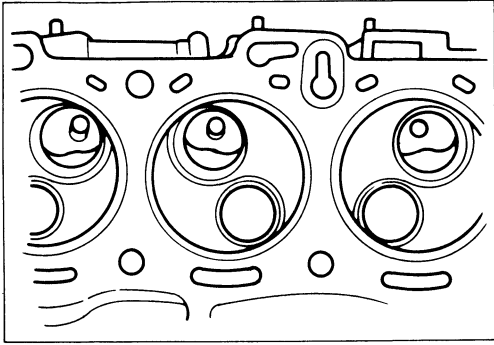

**Combustion chamber**

Remove adhering carbon and inspect the combustion chamber inside, spark plug hole, valve seat insert engagement section and other parts. If there is a crack or considerable damage replace it with a new one.



**CYLINDER BODY**

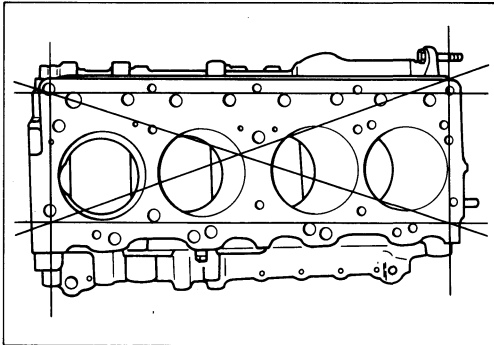

**Distortion of upper face**

Make measurements on the four sides and the diagonals with a straightedge and thickness gauge as shown in the figure. If the limit is exceeded make necessary correction or replacement.

mm(in.)

Standard	Limit	Maximum repairable limit
0.05(0.002) or less	0.2(0.008)	0.4(0.016)

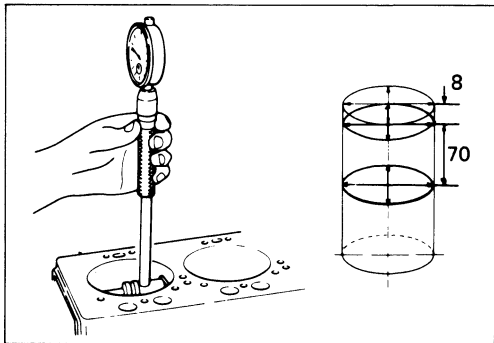

**Cylinder bore**

Measure the cylinder bore diameter at points approximately 8 to 70mm from the upper end in directions in line with and at a right angle to the crankshaft.

mm(in.)

Standard	Limit	Max. bore dia
89.30-89.34 (3.518-3.520)	0.2 (0.008)	90.34 (3.557)



Reboring is necessary if the amount of wear is greater than 0.2mm over standard size, or if scuffing or trace of seizure is noticeable.

All cylinder should be rebored even if only one cylinder fails to meet standard. Replace the cylinder block if bore diameter exceeds max. bore dia. specified above.



Remove steps at upper part of cylinder walls with a ridge reamer whenever the engine is overhauled.

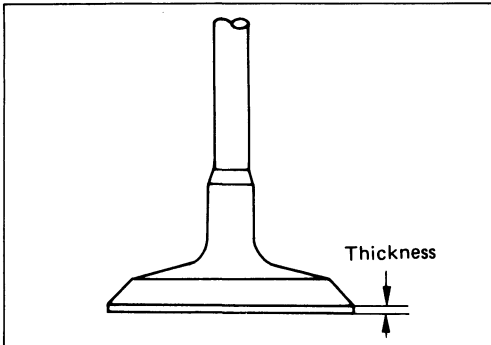
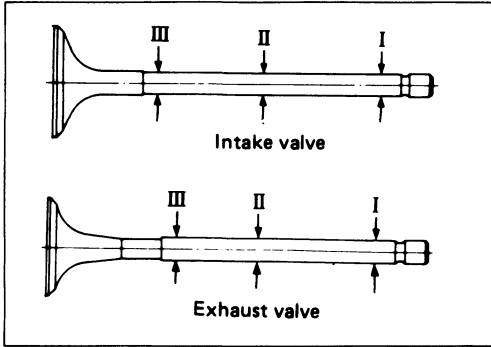

**Valve seat thickness**

Head edge thickness:

mm(in.)

	Standard	Limit
Inlet	1.1 (0.0433)	0.8 (0.0315)
Exhaust	1.3 (0.0512)	1.0 (0.0394)

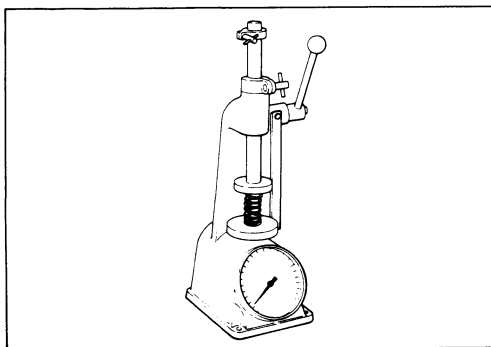
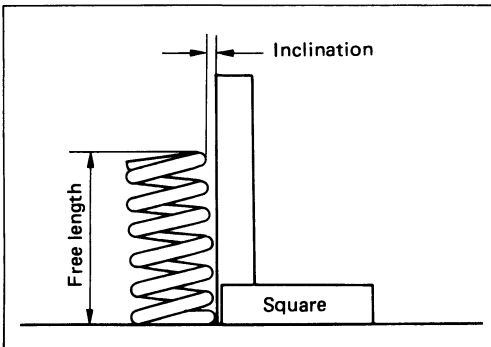

**VALVE GUIDE**

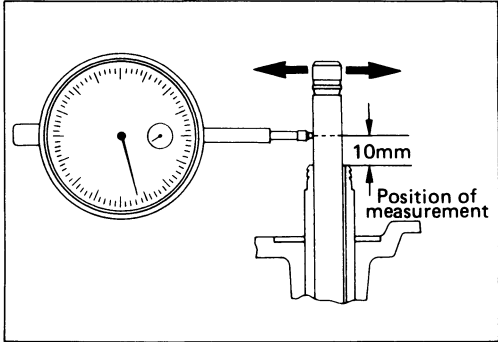

**Valve stem diameter**

Set a dial gauge as shown in the figure and measure the clearance between the valve guide and valve stem.

		mm(in.)
	Standard	Limit
Intake	0.023 - 0.056 (0.009 - 0.0022)	0.2 (0.0079) or more
Exhaust	0.038 - 0.070 (0.0015 - 0.0031)	0.25 (0.0097) or more

**Note:** If the clearance between the valve stem outer circumference and valve guide exceeds the limit replace the valve and valve guide as a pair.

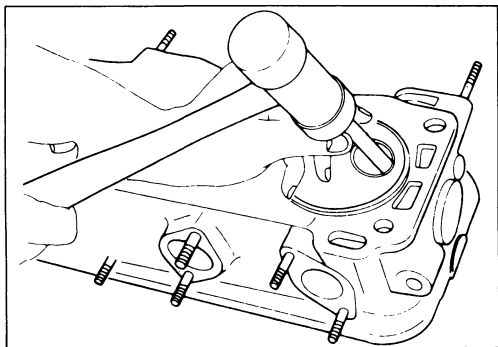

**Valve guide replacement**

Hit the valve guide out from the combustion chamber side to the cam side using a valve guide remover.



Valve guide remover : J-26512-1

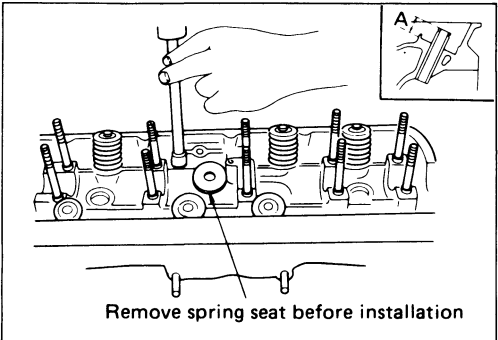

Apply engine oil to the outer circumference of the valve guide and hit it in, with a valve guide installer, until the top end of the installer hits the cylinder head.



	mm(in.)
Height of valve guide upper-end from cylinder head upper face (A)	16.1 - 16.3 (0.634 - 0.642)



Valve guide installer J-26512  
J-26512-1  
J-26512-2

VALVE SEAT

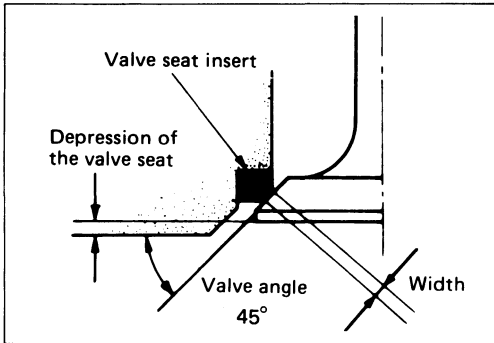

Valve seat insert

Attach a new valve to the cylinder head and measure the amount of sinking from the head surface with a depth gauge. If the limit is exceeded replace the valve seat insert.

mm(in.)	
Standard	Limit
1.0 (0.039)	1.7 (0.067)

If the seat contact surface is damaged or made rough or if the wear of the contact width exceeds the limit make necessary correction.

mm(in.)	
Standard	Limit
1.2-1.6 (0.048 - 0.063)	2.0 (0.078)

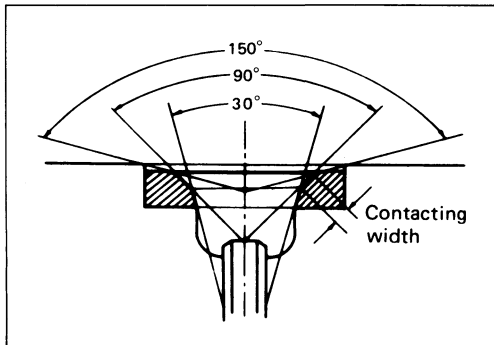

Correction of valve seat

Remove carbon from the seat surface, cut to the minimum extent to remove flaws and roughness of the seat surface with 15°, 45° and 75° valve seat cutters, and thus correct the contact width to a standard value.

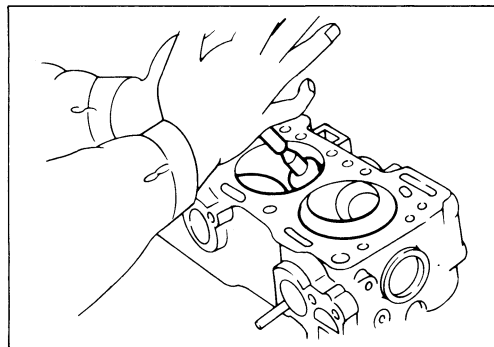

Apply compound to the valve seat surface and fit while turning the valve and hitting light. Insure that the whole circumference contacts the valve in the center of the valve seat surface and that the valve seat contact width is a standard value.

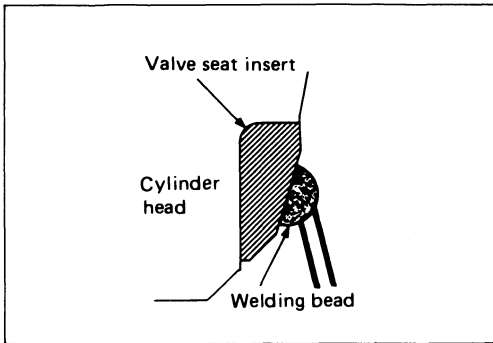

**Valve seat insert replacement**

1. Arc-weld, at several points, a rod to draw it into the valve seat while taking care to avoid damage to the aluminum apply section.
2. When the cylinder head heated by welding is cooled by air for 2 to 5 minutes, the valve seat shrinks because of local cooling of the valve seat. So give a shock to the welded rod and draw it out.
3. Clean the valve seat press-fit section on the cylinder head side while taking care to avoid damage to it, heat and expand the insert press-fit section using steam or other means, and press fit horizontally the valve seat cooled and contracted with dry ice or other means.



Standard fitting interference	mmdh.)	0.08-0.12 (0.0032-0.0047)
-------------------------------	--------	---------------------------

**FLYWHEEL**

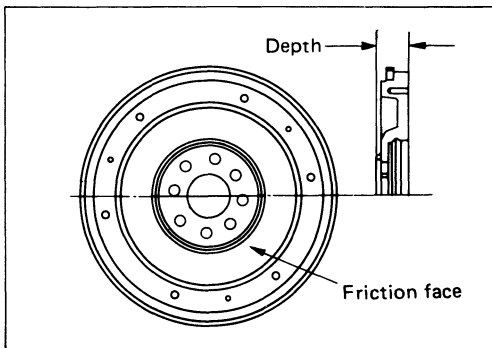

**Flywheel**

Check the flywheel's friction face with the clutch driven plate for cracks and damage.

		mm(in.)
	Standard	Limit
	43.45 (1.711)	42.45 (1.671)

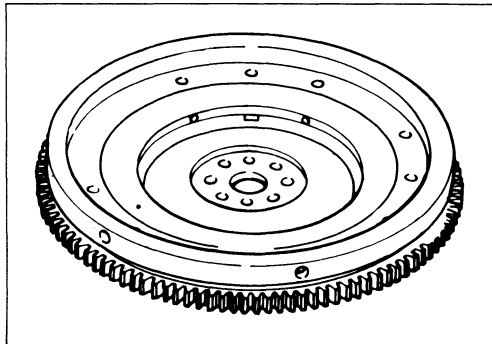

If damage or considerable wear is found in the surfaces of the ring gear teeth, replace it with a new one.

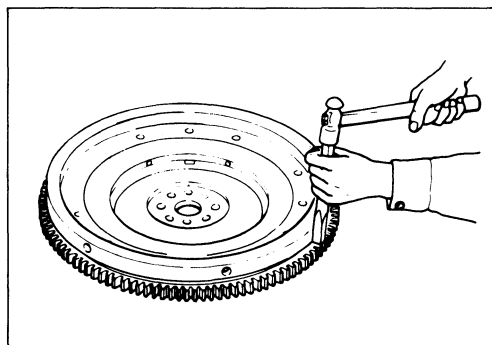

**Ring gear replacement**

Remove the ring gear by hitting with a hammer through a brass rod placed between it and the hammer.

## 01-32 4ZD1 GASOLINE ENGINE

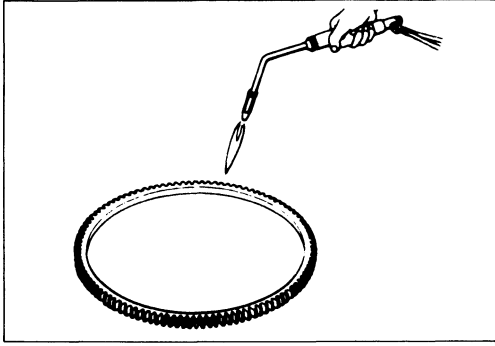

Heat and expand the ring gear evenly with a gas burner or other means and tap it into the flywheel.

**Note:** After shrink fitting confirm that the ring gear is in close contact with the flywheel.

## INLET AND EXHAUST MANIFOLD

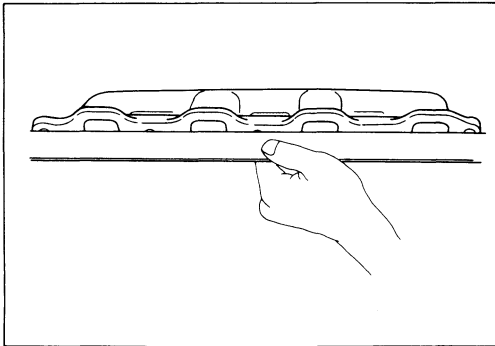

### Inlet manifold

Check the cylinder head fitting face of the intake manifold for distortion.

Limit	mm(in.)	0.4 (0.016)

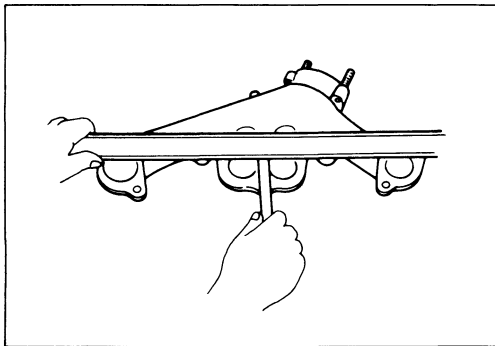

### Exhaust manifold

Check the cylinder head fitting face of the exhaust manifold for distortion.

Limit	mm(in.)	0.4 (0.016)



**ROCKER ARM SHAFT AND ARM ASSEMBLY**

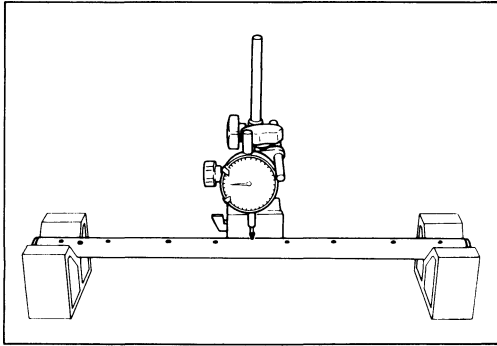

**Rocker arm shaft**

Visually inspect for damage or other abnormal conditions.



Run-out:

mm(in.)	
Standard	Limit
0.2 (0.008) or less	0.4 (0.016)

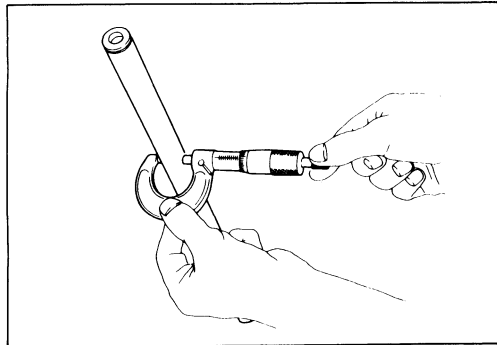

Make measurement on four rocker arm fitting positions, and if the limit is exceeded replace it with a new one.

Diameter:

mm(in.)	
Standard	Limit
20.5 (0.807)	20.35(0.801)

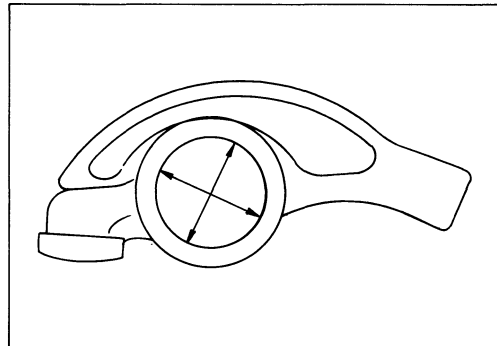

**Clearance between rocker arm shaft and rocker arm**

Measure the inner diameter of the rocker arm, and if the clearance between it and the outer diameter of the rocker arm shaft exceeds the limit, replace the rocker arm or shaft.

mm(in.)	
Standard	Limit
0.005-0.045(0.0020-0.0018)	0.2 (0.0078)

# 01-34 4ZD1 GASOLINE ENGINE

## CAMSHAFT ASSEMBLY

When the limit is exceeded in the following inspection, replace the camshaft.

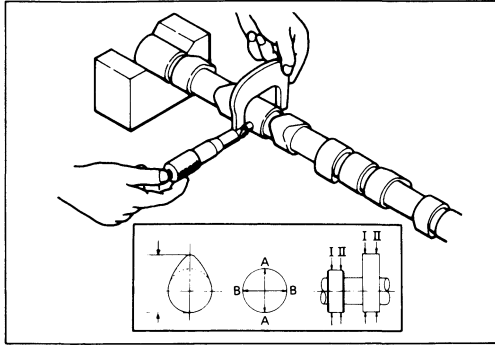

### Camshaft diameter and hight of camlobe

Journal diameter

mm(in.)

	Standard	Limit
Journal diameter	34.0(1.339)	33.8(1.332)
Height of camlobe	36.85(1.452)	36.35(1.432)
Taper	0.05(0.002) or less	0.05(0.002)

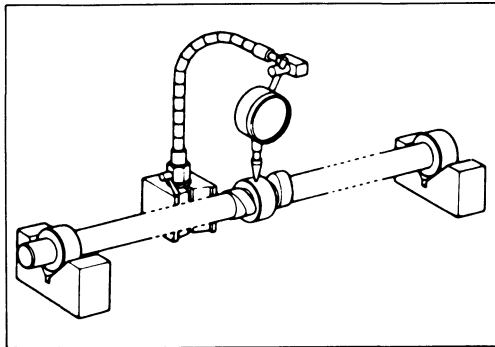

Run out:

mm(in.)

Standard	Limit
0.05(0.002) or less	0.1(0.004)

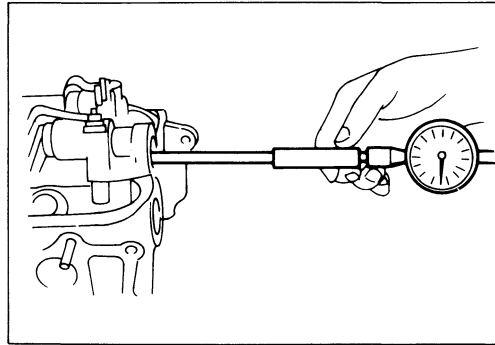

### Clearance between journal and bearing

Tighten the rocker arm shaft bracket with predetermined torque and make measurement.

Torque	kg-m(ft.lbs.)	2.1-2.3 (15.2-16.6)



Clearance between journal and bearing:

mm(in.)

Standard	Limit
0.065 - 0.110 (0.0026 - 0.0043)	0.15 (0.0059)

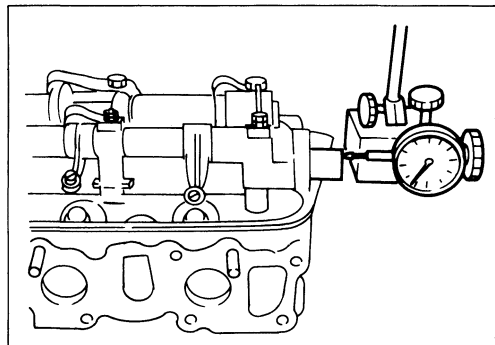

End play

mm(in.)

Standard	Limit
0.05 - 0.15 (0.0002 - 0.0059)	0.2 (0.0079)

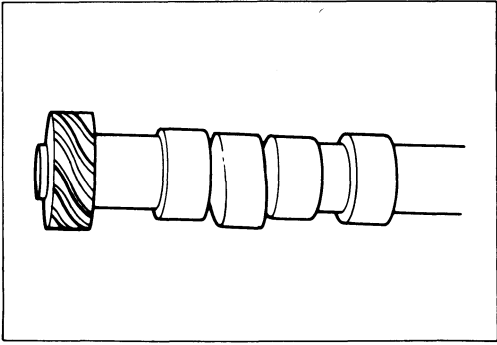

**Distributor drive gear**  
Check for wear or damage.

### CRANK SHAFT PILOT



**Crankshaft pilot bearing and sleeve**  
Turn the pilot bearing with your finger and check for bearing backlash or abnormal noise.

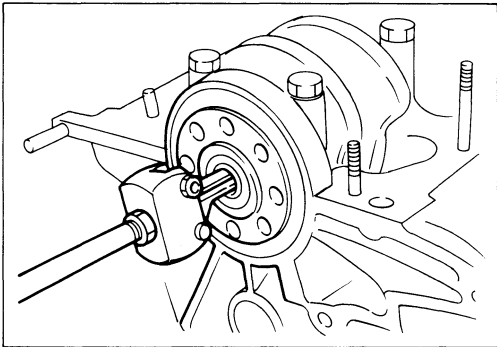

When an abnormality is noted, remove the pilot bearing using a pilot bearing puller and replace it with a new one.



Pilot bearing remover : J-23097  
Sleeve remover : J-33950

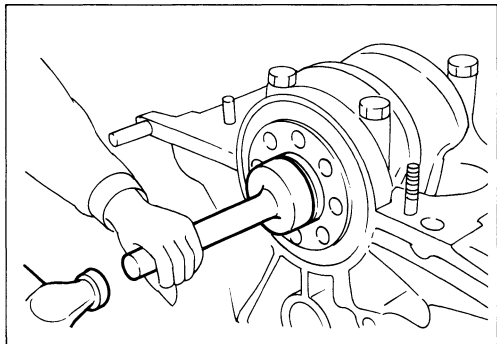

Attach the pilot bearing using a pilot bearing installer.

Pilot bearing installer : J-26516-A  
Sleeve installer : J-29818



CRANKSHAFT AND BEARINGS

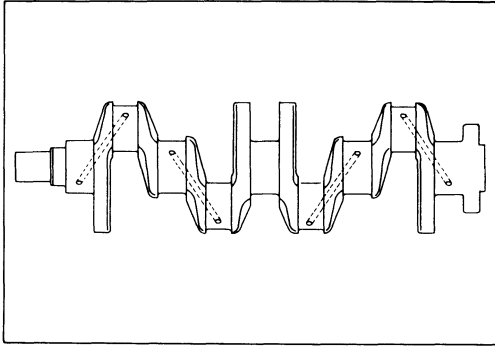

**Crankshaft and bearings**

Check the faces of the crankshaft journals, crankpins and oil seal fitting faces for wear and damage and oil passages for restrictions.

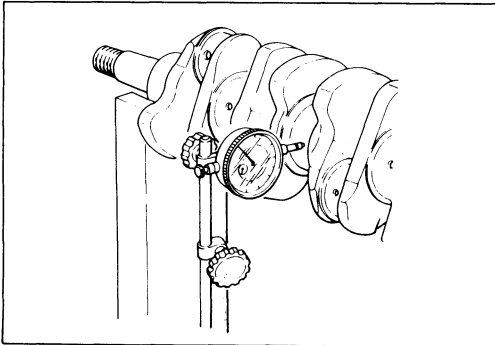

Check for run-out by turning the crankshaft slowly with the probe of a dial indicator set against the No. 3 journal.

Run out:

		mm(in.)
	Standard	Limit
	0.03 (0.0012) or less	0.1 (0.004)

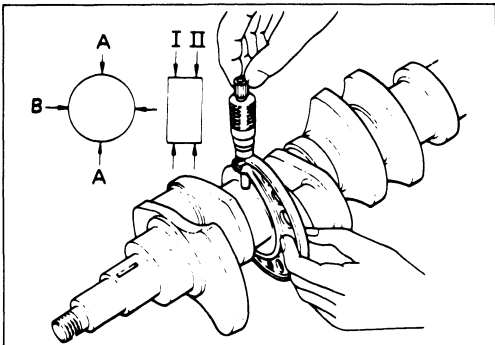

Measure the journal and pin diameters for front and back (I and II shown in the figure) in two directions of A and B.

Crankshaft journal and pin diameter:

			mm(in.)
	Journal dia.	Pin dia.	
Standard	55.920-55.935 (2.2032-2.2038)	48.925-48.940 (1.9276-1.9282)	
Limit for use	55.420 (2.184)	48.425 (1.908)	

When the wear of the journal or pin exceeds the limit, replace the crankshaft.

Crankshaft journal and pin taper:

			mm(in.)
	Journal	Pin	
Limit for use	0.05 (0.002)	0.05 (0.002)	

When the limit is exceeded correct with a grinder and replace with an undersized bearing.

CRANKSHAFT AND CRANKPIN BEARINGS

(mm)

Bearing Size	Journal Diameter	Pin Diameter
STD	55.920-55.935	48.925-48.940
U/S 0.25	55.670-55.685	48.675-48.690
U/S 0.50	55.420-55.435	48.425-48.440

If the amount of wear is beyond the value specified, correct with crankshaft grinder and install undersize bearings.

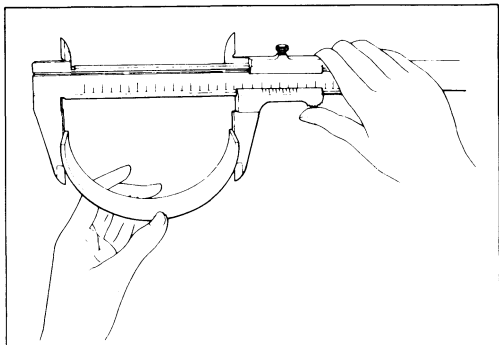

**Crankshaft bearing**

Bearing tension free width:

mm(in.)

	Limit
Crankshaft bearing	More than 59.25 (2.334)
Connecting-rod bearing	More than 52.25 (2.059)

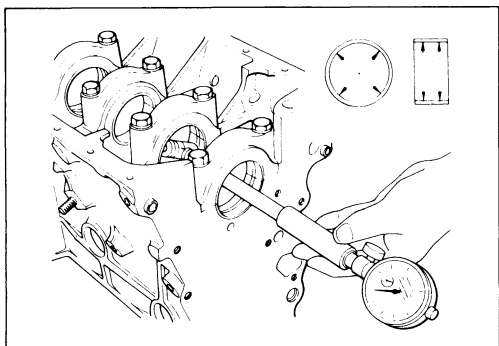

Attach the bearing normally to the body and bearing caps and tighten the bearing cap with predetermined torque and measure the inner diameter.

Torque	kg-m(ft.lbs.)	9 - 11 (65.1 - 79.5)

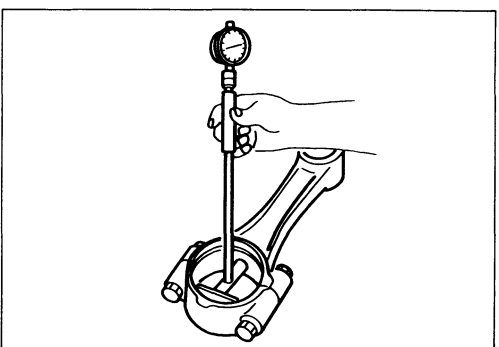

Attach the bearing normally to the larger end of the connecting-rod and tighten the connecting-rod cap with predetermined torque and measure the inner diameter.

Torque	kg-m(ft.lbs.)	5.8 - 6.2 (41.9 - 44.8)

Clearance between pins and bearings:

mm(in.)

Standard	Limit
0.011 - 0.065 (0.0004 - 0.0026)	0.12 (0.0047)

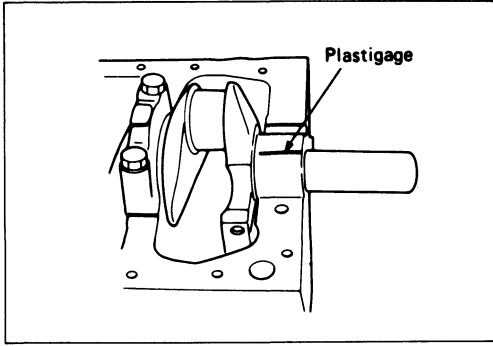

**Measurement of clearance using plastigage**

Clean the journal cap and bearing.  
Lay a plastigage over the full width of the bearing.

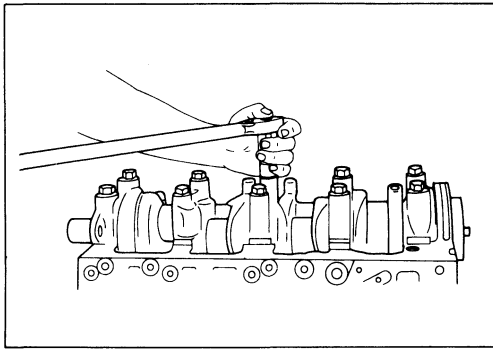

Tighten the bearing cap with predetermined torque.

Torque	kg-m(ft.lbs.)	9 - 1 1 (65.1 - 79.5)
--------	---------------	-----------------------



Do not turn the crankshaft

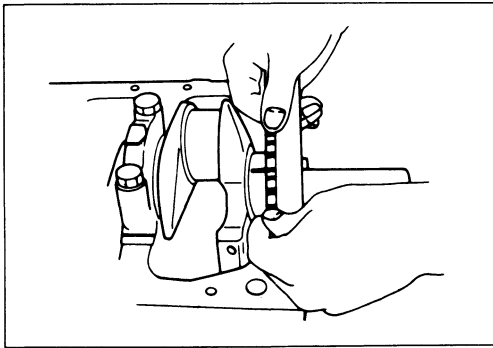

Check the width of plastigage stuck to either crankshaft or bearing against the scale printed on the container of the plastigage.

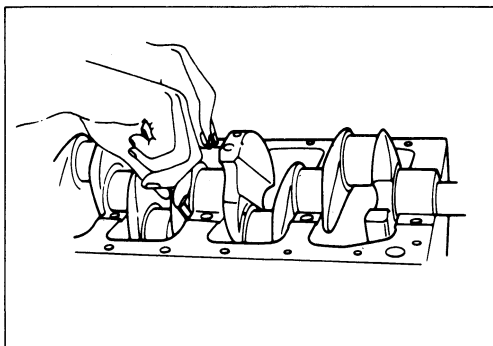

Measure play at thrust bearing installed on bearing cap No. 3 using a feeler gauge.

Crankshaft end play:

		mm(in.)
Standard		Limit
0.06 - 0.25 (0.0024 - 0.0099)		0.3 (0.012)

**PISTON AND PISTON RING**



**Pistons**

If there is a crack, streak, or considerable wear found in the piston, replace it with a new one.



Clearance between piston and cylinder bore (at Grading piston and measuring position).

If the clearance exceeds the limit, select and use an oversized piston.

Standard	mm(in.)	0.045 - 0.065 (0.0018 - 0.0026)
----------	---------	------------------------------------

Piston grading position (from piston head)

Piston grading position	mm(in.)	42 (1.65)
-------------------------	---------	-----------

Take measurement in direction at a right angle to the piston pin hole.

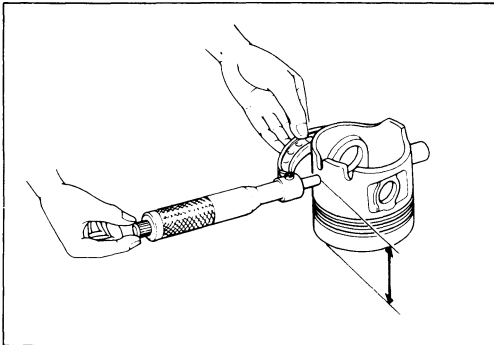

**Reboring Procedure of Cylinder Block**

1. Determine size of oversize pistons to be installed according to largest bore diameter.
2. When the oversize is determined, measure the outside diameter of the pistons at a grading point below the upper face of the piston (grading positions) and in a direction at right angles to the crankshaft.

Calculate the cylinder bore diameter to be obtained after reboring by the following formula:

$$\text{Cylinder bore diameter (after boring)} = D + C - H$$

D: Oversize piston diameter (mm)

C: Piston clearance (0.035 — 0.055 mm)

H: Allowance for honing (0.03 mm or less)

	mm
Grading position	42
STD piston	89.255 - 89.295
O/S piston 0.50	89.755 - 89.795
O/S piston 1.00	90.255 - 90.295
Allowance for honing	0.01 - 0.03
Variance of bore diameter	0.02 or less

(Reference) Grade of cylinder Bore and Piston (STD size)

Grade	Cylinder bore diameter	Piston diameter
(A)	89.300 - 89.320	89.255 - 89.275
(C)	89.321 - 89.340	89.276 - 89.295

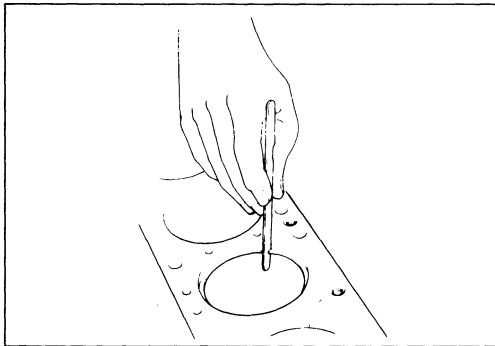

**Piston ring**

Remove carbon adhering to the piston ring and inspect the piston ring for damage.



Put the ring in the cylinder, push it in with the head of the piston to the section of minimum inner diameter, and measure the abutment clearance. If the limit is exceeded replace it with a new one.



	Standard	Limit
1 st compression ring	0.30-0.45 (0.012-0.018)	1.5 (0.059)
2nd compression ring	0.25-0.40 (0.010-0.016)	1.5 (0.059)
Oil ring	0.20-0.70 (0.008-0.028)	1.5 (0.059)

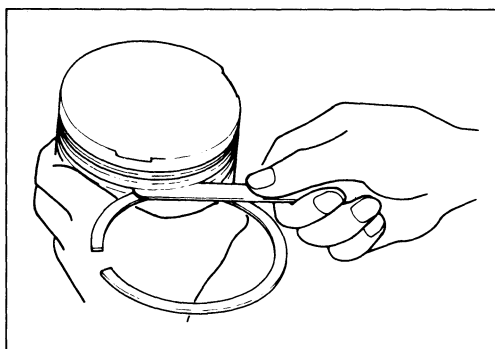

**Clearance between piston ring and ring groove:**

Remove carbon in the gaps between the piston ring grooves and rings, and measure the outer circumference at several points with a thickness gauge.



	Standard	Limit
1 st compression ring	0.025-0.060 (0.001-0.0024)	0.15 (0.006)
2nd compression ring	0.020-0.055 (0.001-0.0024)	0.15 (0.006)



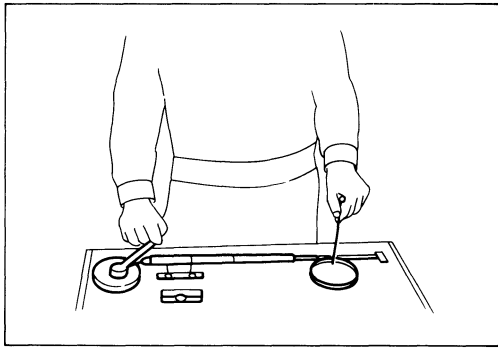

**Piston ring tension**

Measure the piston ring tension with a piston ring tester. If the tension is beyond the limit replace the piston ring with new one.

		kg(lbs.)
	Standard	Limit
1 st compression ring	1.11-1.59 (2.448-3.506)	0.8 (1.764)
2nd compression ring	0.89-1.31 (1.962-2.889)	0.6 (1.323)
O-ring	3.05-4.35 (6.725-9.592)	2.0 (4.410)

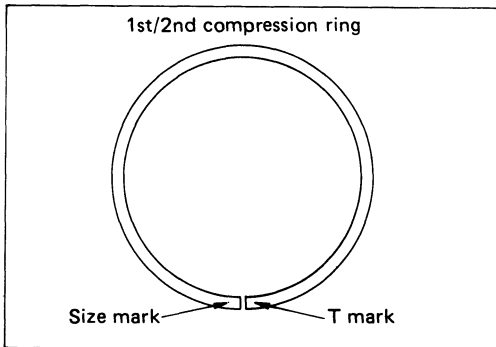

**Piston ring size mark**

	1 st comp. ring	2nd comp. ring	Oil ring
STD	None	None	Red
O/S 0.50	50	50	Blue
O/S 1.00	100	100	Yellow

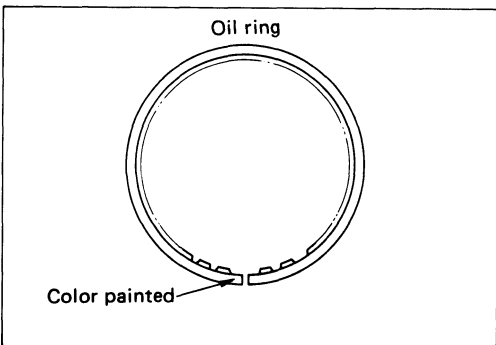

CONNECTING-ROD AND PISTON PIN

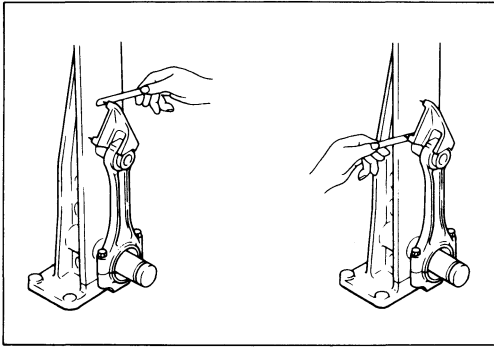

**Connecting-rod and piston pin**

**Connecting-rod**

Measure distortion and parallelism between the larger end hole and smaller end hole using a connecting-rod aligner. If the limit is exceeded replace it with a new one.

Connecting-rod aligner (Per length of 100 mm (3.97 in.)

	mm(in.)	
	Standard	Limit
Distortion	0.05 or less (0.002 or less)	0.2 (0.008)
Parallelism	0.05 or less (0.002 or less)	0.15 (0.006)

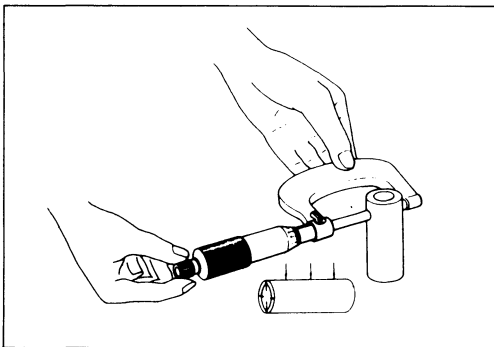

**Piston pin**

Visually inspect for damage, wear or the abnormal conditions.

Outside diameter:

		mm(in.)
Standard	Limit	
23.0 (0.906)	22.97 (0.905)	

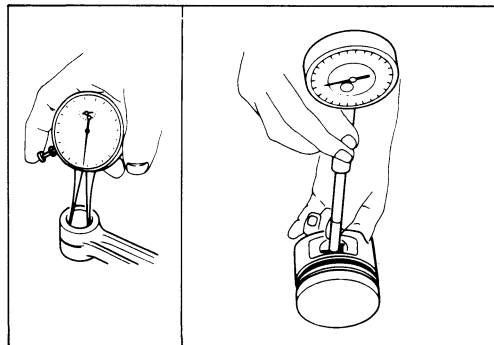

Clearance between piston pin and connecting-rod small end.

		mm(in.)
Standard	Limit	
0.008 - 0.020 (0.0003 - 0.0008)	0.05 (0.002)	



**Note:** If the limit is exceeded replace the piston pin or connecting-rod to bring the clearance into the standard value range.

**TIMING BELT TIMING PULLEY AND TENSION SPRING**



**INSPECTION AND REPAIR**

**TIMING BELT**

**Caution in handling**

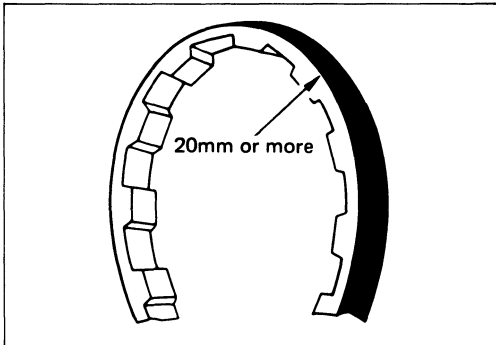

1. Do not bend in less than 20 mm in radius.

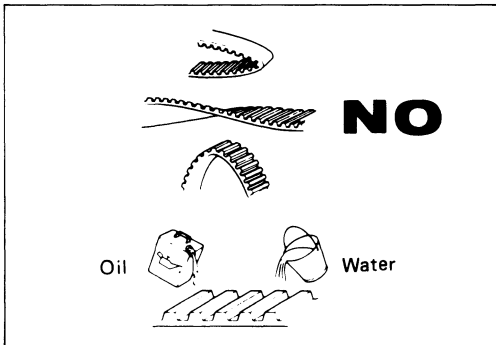

2. Avoid twisting or kinking the belt and keep it free from water, oil, dust and other foreign matter.

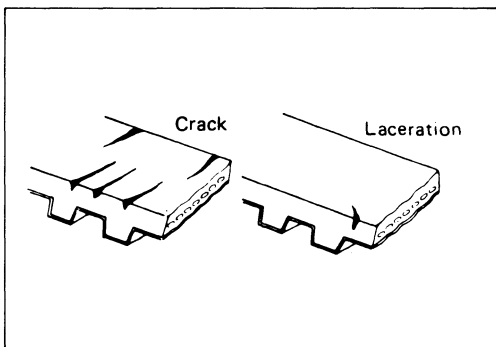

**Visual check**

The belt must be replaced if cracks are found in the side and rear faces.

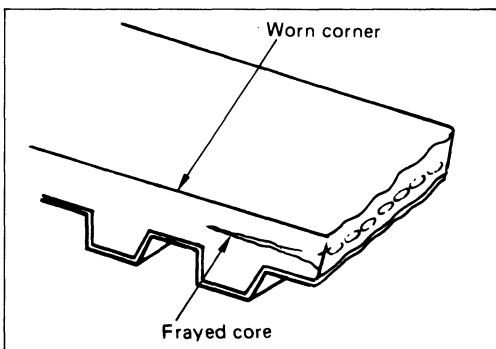

Also replacement is necessary when abnormal wear is found in the side face.

# 01-44 4ZD1 GASOLINE ENGINE

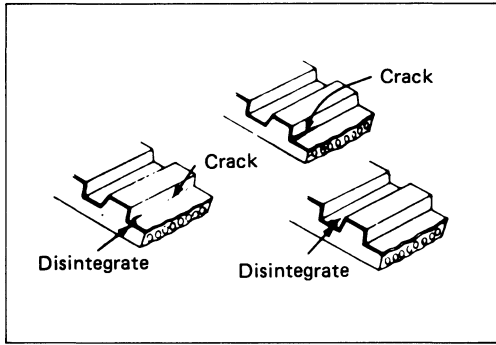

Replacement is necessary when fabric is found to be cracked or disintegrated.

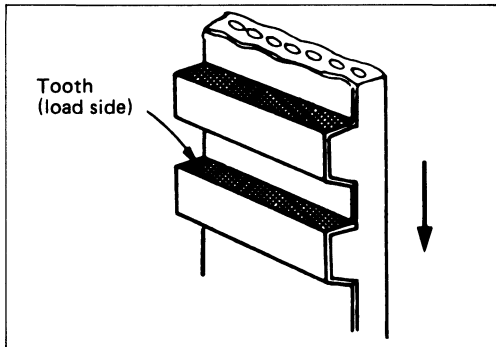

Replacement is also necessary when cogs are found to have abnormal wear.

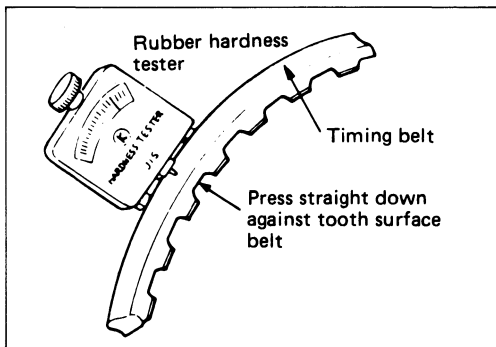

Take measurements at 3 — 5 points around the circumference of the belt. The belt must be replaced even if a single measurement is beyond the limit.

Limit of rubber hardness (HS)	90
-------------------------------	----



Rubber hardness tester



The timing belt is a vital part of the engine and should be maintained properly.

**Timing pulley and tension spring**

- Crankshaft pulley
- Camshaft pulley
- Oil pump pulley
- Idler pulley



**Visual check**

If uneven wear, crack or wear exceeding the limit is found in the pulley, replace it with a new one.

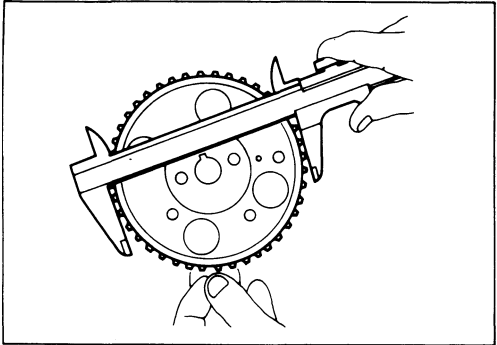

**Timing pulley**

Outside diameter:

mm(in.)



Pulley	Standard	Limit
Crankshaft	65.33 (2.574)	65.23 (2.570)
Oil pump	113.84 (4.485)	113.74 (4.481)
Camshaft	132.03 (5.202)	131.93 (5.198)

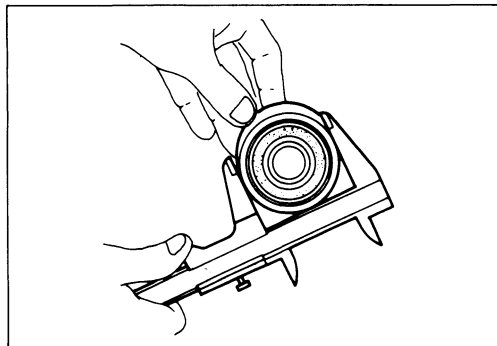

**Tension pulley**

Check the roller for excessive wear and damage.

Check to see that the roller rotates smoothly.

Check to see that there is no play in the pulley shaft/fixing plate caulked area.

Outside diameter:

mm(in.)

Standard	Limit
60.00 (2.364)	<b>59.80 (2.356)</b>

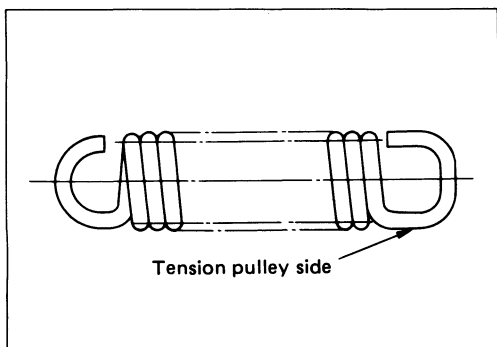

**Tension spring**

Check for tension:

	Set length	Set force
Tension	78.8 mm (3.105 in.)	23.8 - 25.8 kg (172 - 186 lbs.)

If the set length or set force is out of the specified range, replace the tension spring with a new one.



# REASSEMBLY

## MINOR COMPONENTS

### PISTON AND CONNECTING-ROD ASSEMBLY

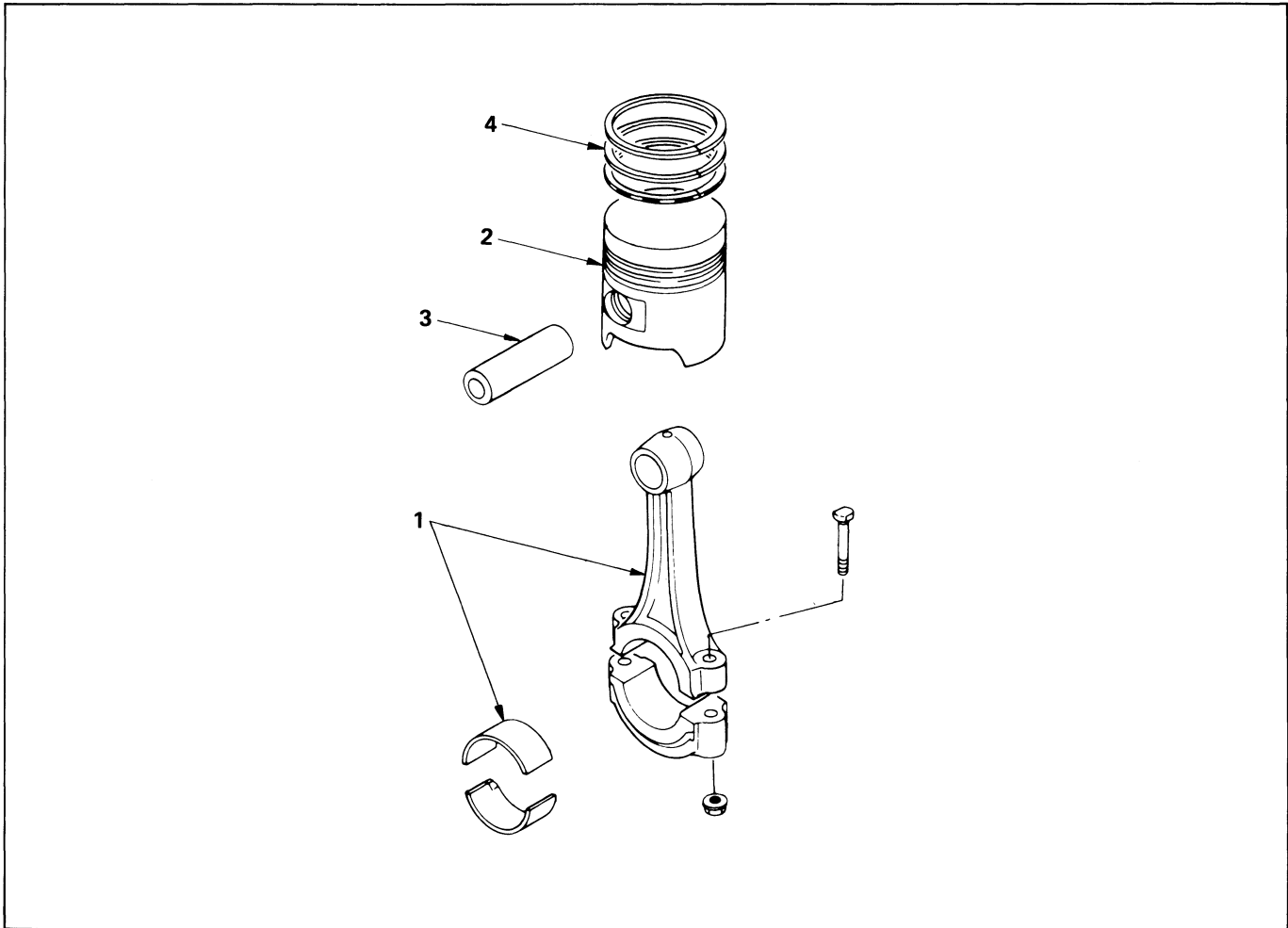

#### Reassembly steps

- |   |                                |   |                |
|---|--------------------------------|---|----------------|
| A | 1. Connecting-rod with bearing | A | 3. Piston pin  |
| • | 2. Piston                      | • | 4. Piston ring |



#### Important operations

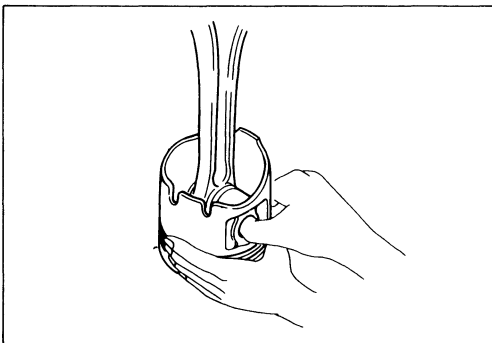

1. Connecting-rod
2. Piston

Apply engine oil to the piston and connecting-rod and then touch the piston hole with finger to check if insertion is possible.

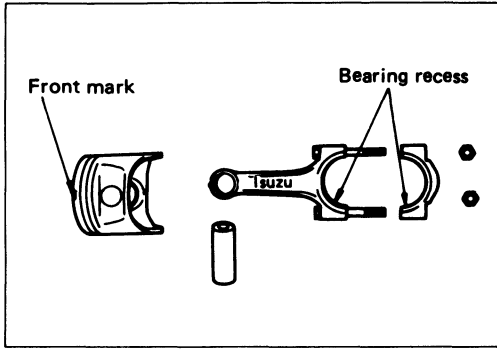

Bring the capital letter ISUZU side of the connecting-rod into agreement with the cut-out front mark of the piston.

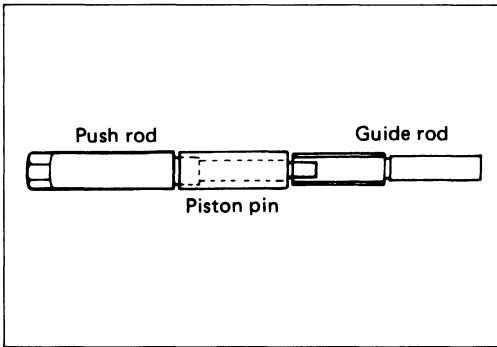

Insert the piston pin into push rod, then screw these parts into guide rod.

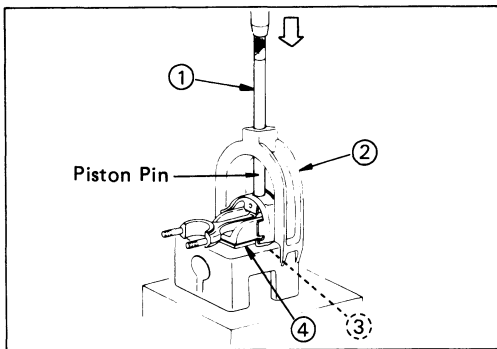

### 3. Piston pin

Press in the piston pin using a piston pin service set piston support and installer and a press.

Remover and installer : J-24086

- 1. Installer : J-24086-9
- 2. Base fixture : J-24086-12
- 3. Pin guide : J-24086-5
- 4. Piston support : J-24086-75

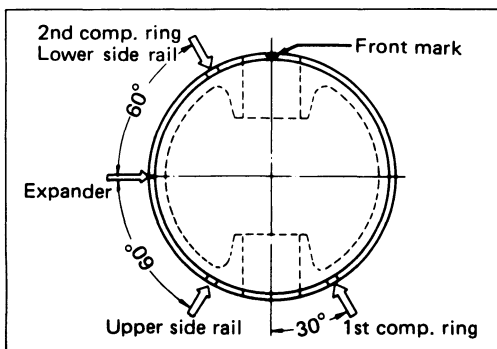

### 4. Piston ring

Install the oil control ring assembly in the order of expander ring, lower side rail and upper side rail.

Assemble the piston rings to the piston so that the T mark is turned up.

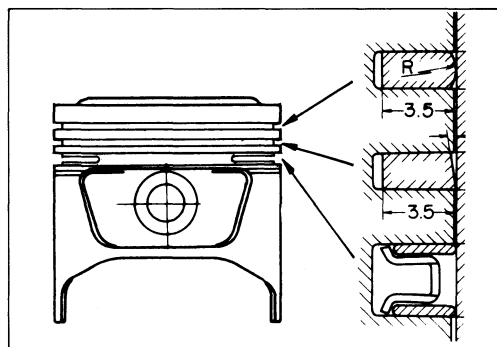

# 01-48 4ZD1 GASOLINE ENGINE

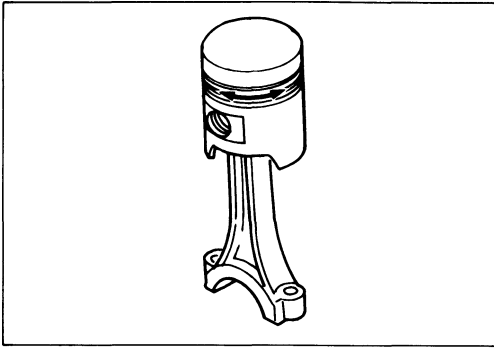

After installation of piston rings, apply engine oil to the circumference of the rings and check that each ring rotates smoothly.

## ROCKER ARM SHAFT

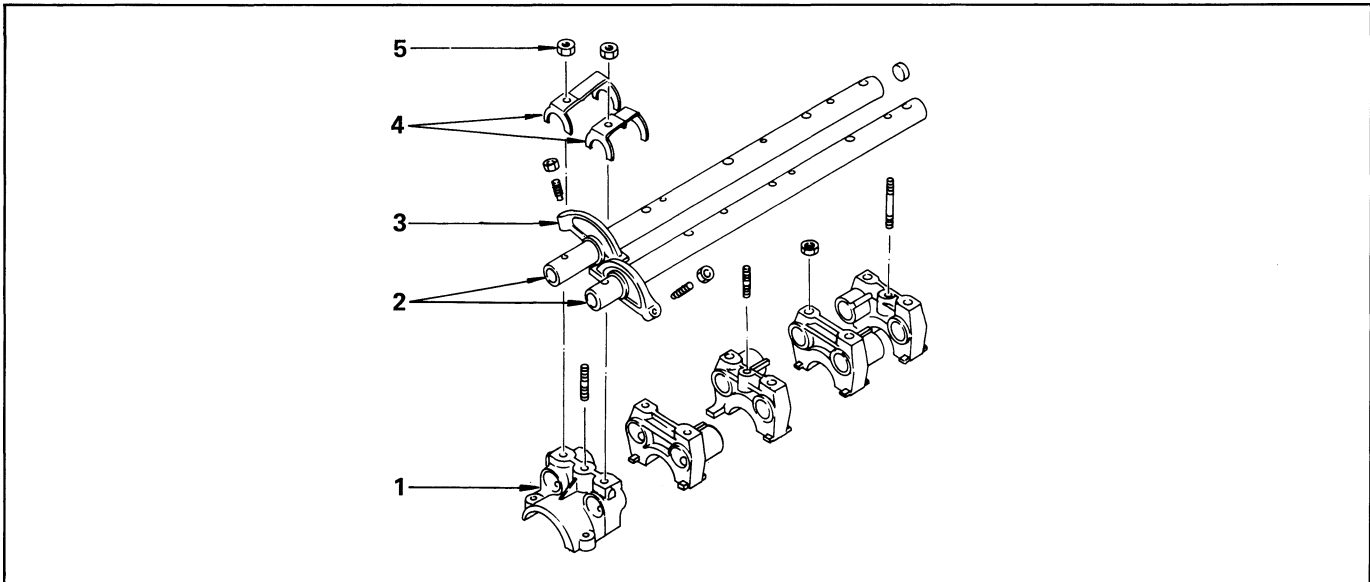

### Reassembly steps

1. Bracket; rocker arm
2. Shaft; rocker arm
3. Rocker arm
4. Spring ; rocker arm
5. Nut; rocker arm bracket



### Important operations



2. Shaft; rocker arm



3. Rocker arm

Apply oil sufficiently to the rocker arm and shaft. Place the longer end of the shaft on the exhaust side, the shorter end on the inlet side, and the shaft mark to the front

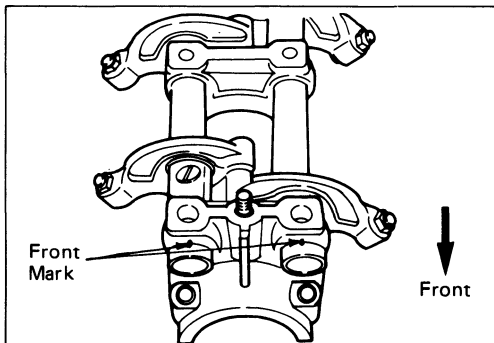



CYLINDER HEAD ASSEMBLY

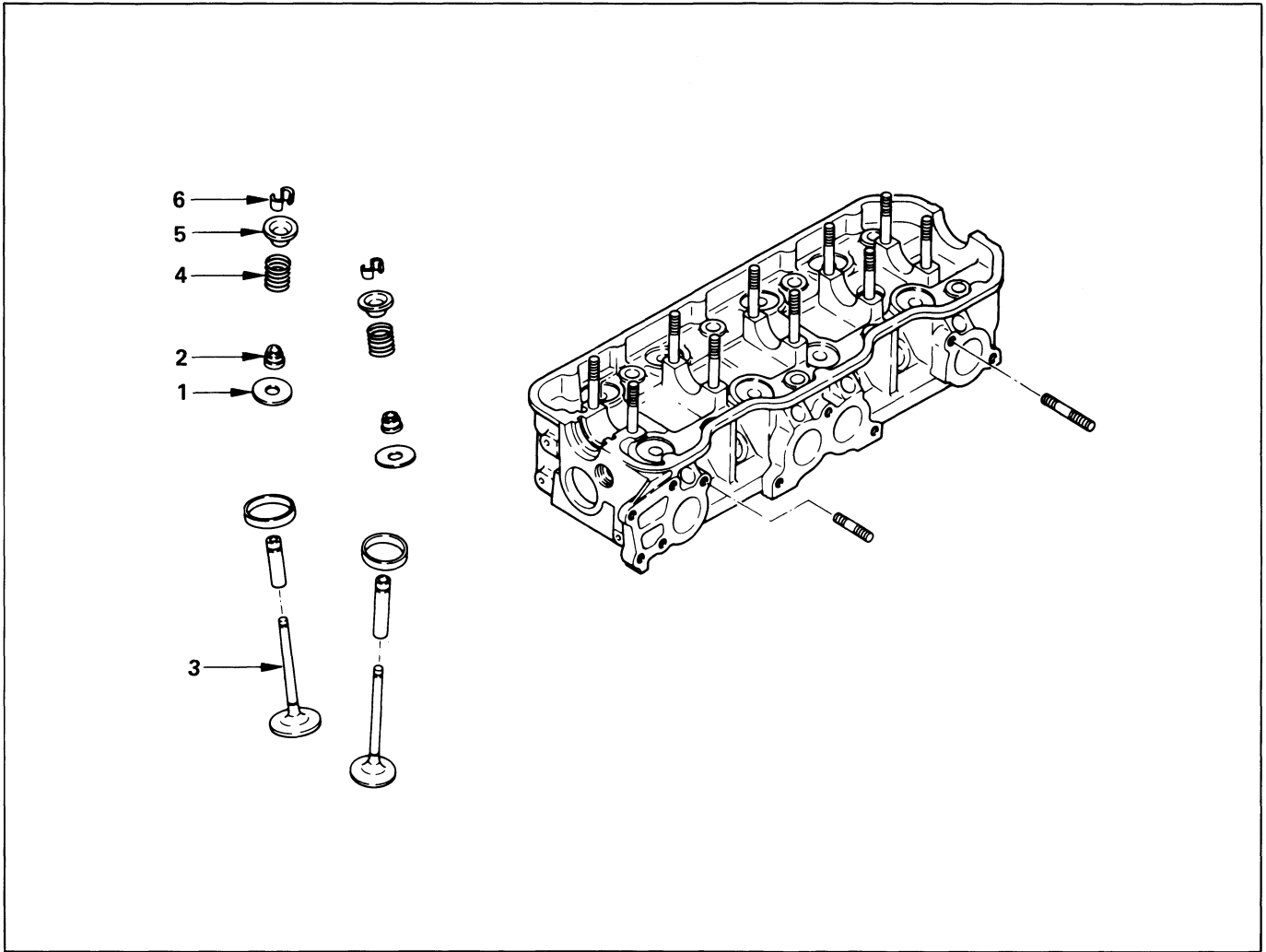

**Reassembly steps**

- |                      |                      |
|----------------------|----------------------|
| 1. Lower spring seat | 4. Valve spring      |
| 2. Oil controller    | 5. Upper spring seat |
| 3. Valve             | 6. Split collar      |



**Important operation**

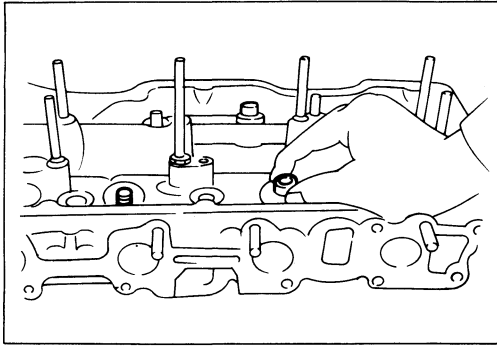

1. Lower spring seat
2. Oil controller

Install the spring seat (lower) and fit the oil controller in the valve guide.

**Note:** Be sure to set the inner projection of the oil controller in the head groove of the valve guide.



3. Valve

Apply engine oil to the valve stem and insert it into the valve guide.

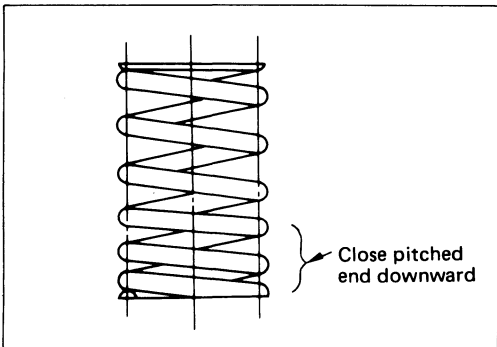

4. Valve spring

Install the inner and outer springs with light green colored ends turned to lower seat or install the valve springs with their close pitched end down.

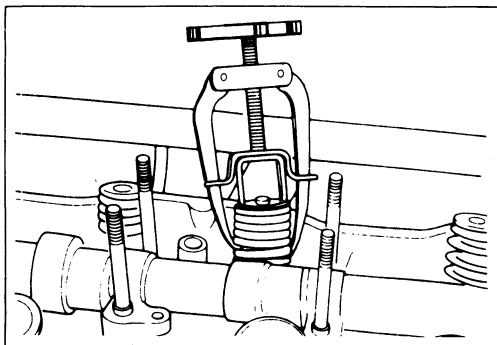

6. Split collars

Compress the spring with the aid of valve spring compressor, then install the valve collars properly.

When compressing the spring, push the valve up by your hand.

Valve spring compressor : 26513-A

## MAJOR COMPONENTS (1)

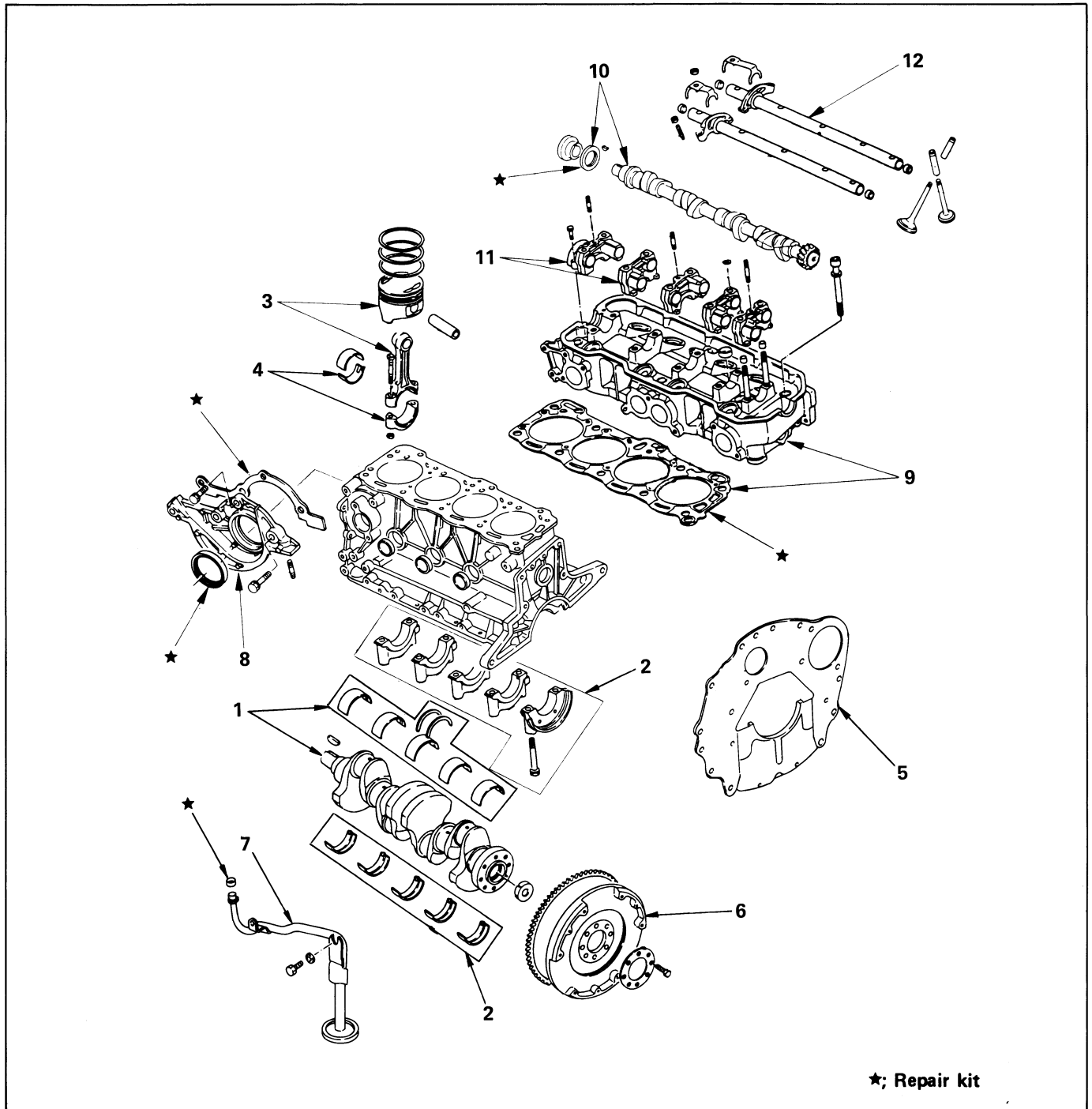

## Reassembly steps

- |   |                             |
|---|-----------------------------|
| 1. Crankshaft bearing and thrust bearing  | 6. Flywheel                 |
| 2. Crankshaft bearing cap and bearing     | 7. Oil pipe assembly        |
| 3. Piston and connecting-rod              | 8. Front oil seal retainer  |
| 4. Connecting-rod bearing cap and bearing | 9. Cylinder head and gasket |
| 5. Rear plate                             | 10. Camshaft                |
|   | 11. Rocker arm bracket      |
|   | 12. Rocker arm shaft        |



**Important operation**

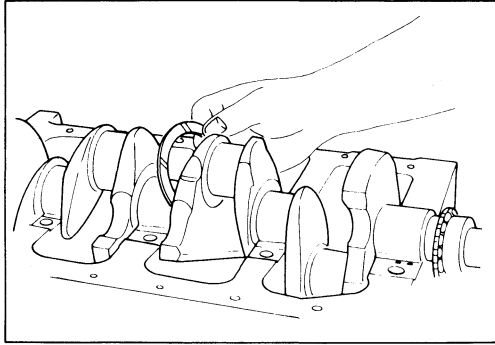

**1. Crankshaft, bearing and thrust bearing**

Apply engine oil sufficiently to the inner surface of the bearing and place the crankshaft on it.

**Note:** Assemble with the oil groove of the thrust washer turned outward.

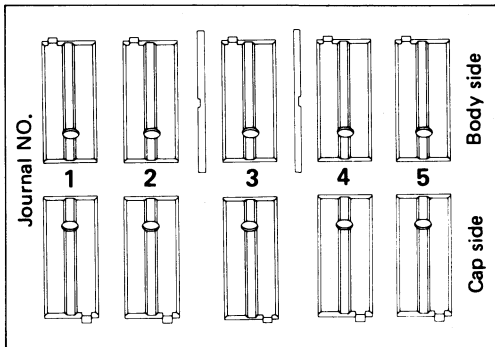

The bearing should be installed correctly in their respective position, install the thrust bearing with the oil grooved side turned outward.

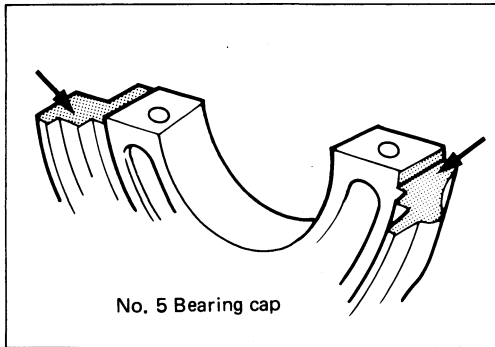

Apply silicon gasket to the fit surface of No. 5 bearing cap and assemble with care to avoid any misalignment between the rear surface of the cylinder body and that of the bearing cap.

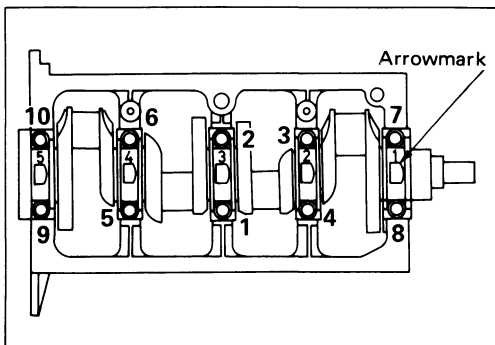

**2. Crankshaft bearing cap and bearing**



Apply engine oil to the threads and seating face of the bolts. Install the bearing caps in sequence of cylinder numbers with the arrow mark pointing to front of engine and semitighten the bolts.

Then retighten the bolts to specification.

Torque	kg-m(ftlbs.)	9-11 (65.1-79.5)
--------	--------------	------------------

After tightening, check to make certain the crankshaft rotates smoothly.

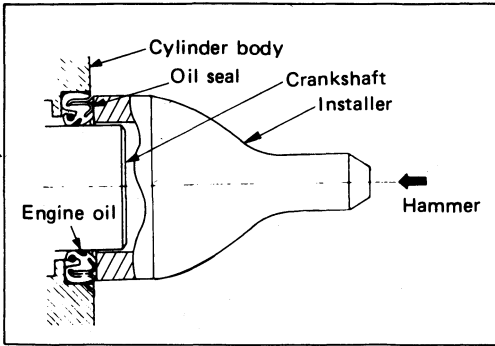

Apply engine oil to the lip of the rear oil seal and set the oil seal in place using an installer.



Crankshaft rear oil seal installer : J-29818

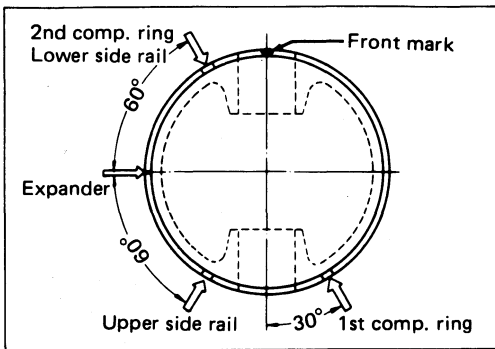

### 3. Piston and connecting-rod

Fit the bearing into the connecting-rod and bearing cap and apply engine oil. Confirm that the opening portion of the piston ring is positioned as shown in the figure and then apply engine oil to the outer circumference of the piston.

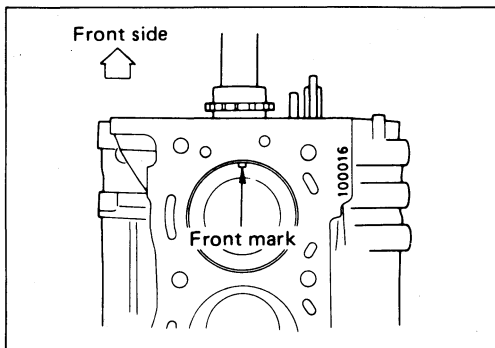

Insert the piston and connecting-rod assembly into cylinder bore with the front mark on the piston turned to the front of engine using the piston ring compressor and hammer handle.

Piston ring compressor : J-8037

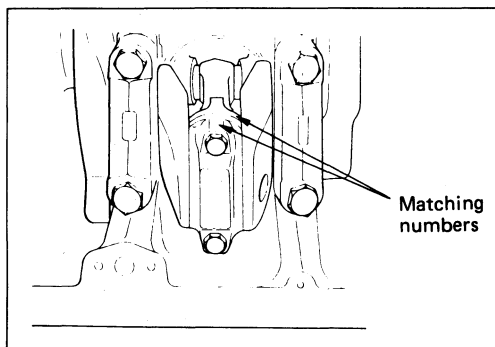

### 4. Connecting-rod bearing cap and bearing

Bring the matching (cylinder) number of the connecting-rod bearing cap into agreement with that of the connecting-rod.

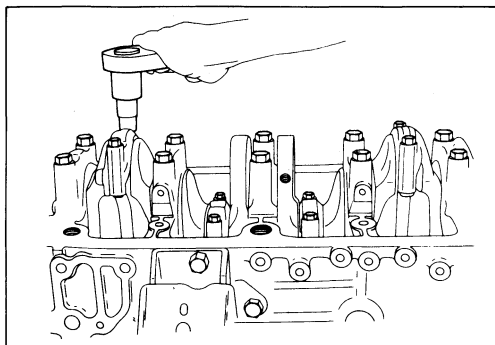

Apply engine oil to the threads, then install and tighten the bolt to specification.



Torque	kg-m(ft.lbs.)	5.8-6.2 (41.9-44.8)
--------	---------------	---------------------

After tightening bolt, check to make certain the crankshaft rotates smoothly.

# 01-54 4ZD1 GASOLINE ENGINE

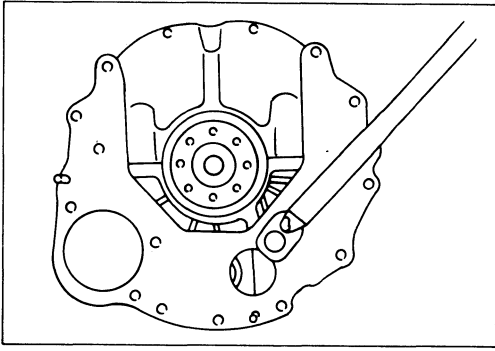

## 5. Rear plate

Install the rear plate in position by aligning it with dowel on the cylinder body.

Torque	kg-m(ft.lbs.)	4.0-6.0(2.89-4.34)
--------	---------------	--------------------

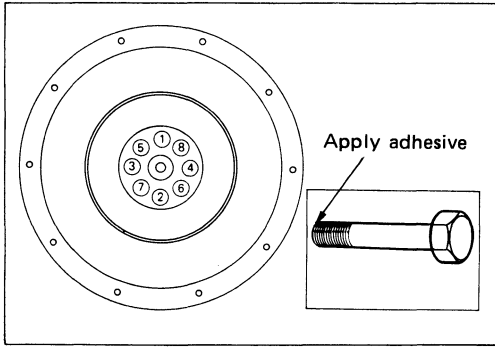

## 6. Flywheel

- (1) Apply adhesive to the first thread of the bolt.
- (2) Attach the flywheel, hold the crankshaft and tighten with predetermined torque diagonally with the pallet of the washer turned outward.
- (3) Be sure to replace the flywheel fitting bolts with new ones because they cannot be reused.

Torque	kg-m(ft.lbs.)	5.5-6.5(39.8-46.9)
--------	---------------	--------------------

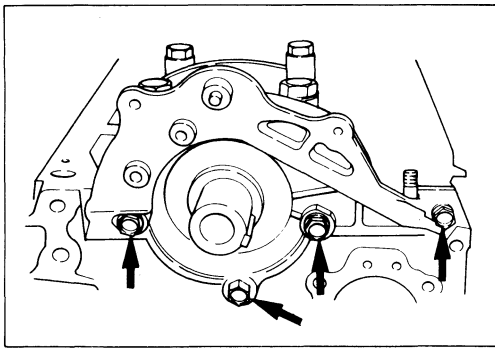

## 8. Front oil seal retainer

Apply engine oil to lipped portion of oil seal, then install the front oil seal retainer by aligning it with the dowels on the cylinder body together with gasket. The gasket should be flush with the face of the cylinder face.

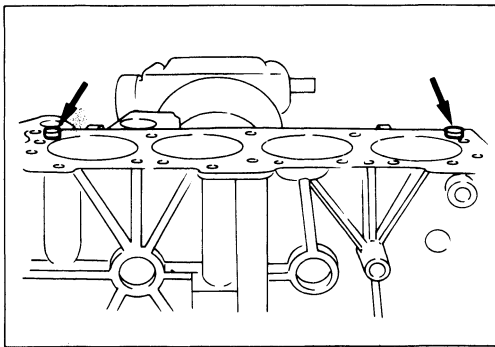

## 9. Cylinder head and gasket

Clean the upper face of the cylinder head and attach the dowels.

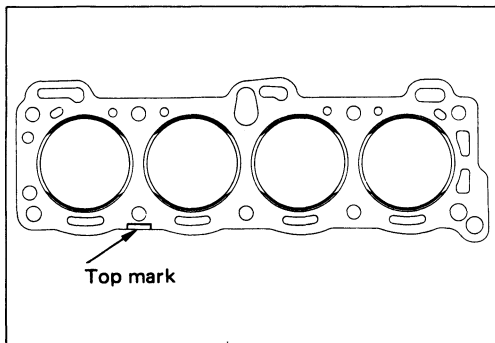

Turn the TOP mark of the cylinder head gasket upwards and attach it so as to fit the dowel.

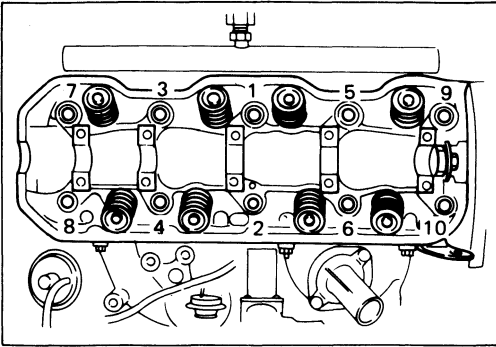

Apply engine oil to the threaded sections of the head bolts and temporarily tighten them in the order indicated in the figure, followed by tightening with predetermined torque.

		kg-m(ft.lbs.)
Torque	First step	8.0 (57.8)
	Final step	9.0-11.0 (65.1-79.5)

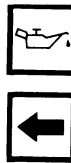
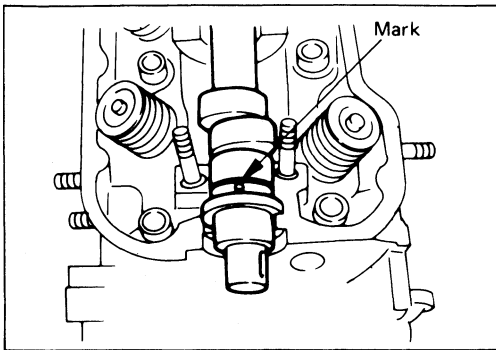

**10. Camshaft**

Apply engine oil sufficiently to the journal of the camshaft and the journal and thrust receivers of the head. Turn the camshaft mark upward.

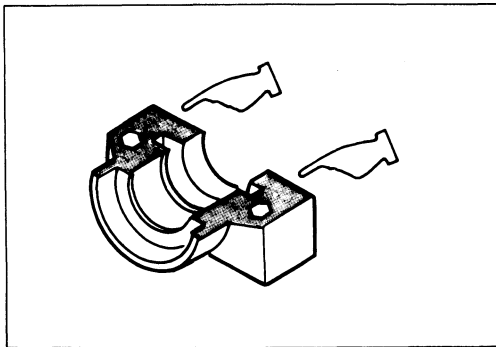

**11. Rocker arm bracket**

Apply silicon gasket beforehand to the front side of the fit surface of No. 1 rocker arm bracket with the cylinder head.

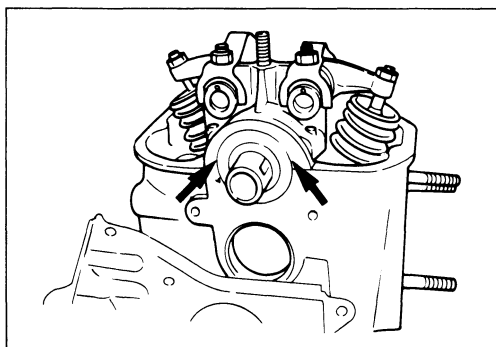

**12. Rocker arm shaft**

Assemble the rocker arm assembly, with the matchmark turned upward.

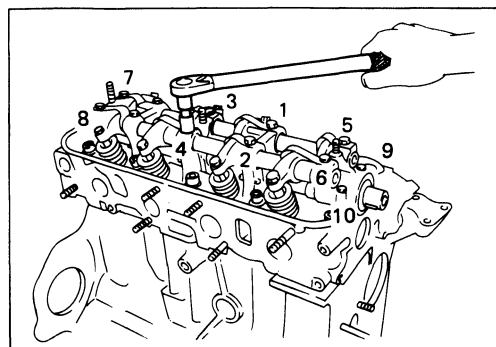

Attach the rocker shaft spring and tighten the shaft bracket in the order indicated with predetermined torque.

		kg-m(ft.lbs.)
Torque	No. 1 - 10 (Nut)	2.1-2.3 (15.2-16.6)
	Bolt	0.6-1.0 (4.34-7.23)



After assembly apply enough drops of engine oil around the rocker arm shaft and valve.

MAJOR COMPONENTS (2)

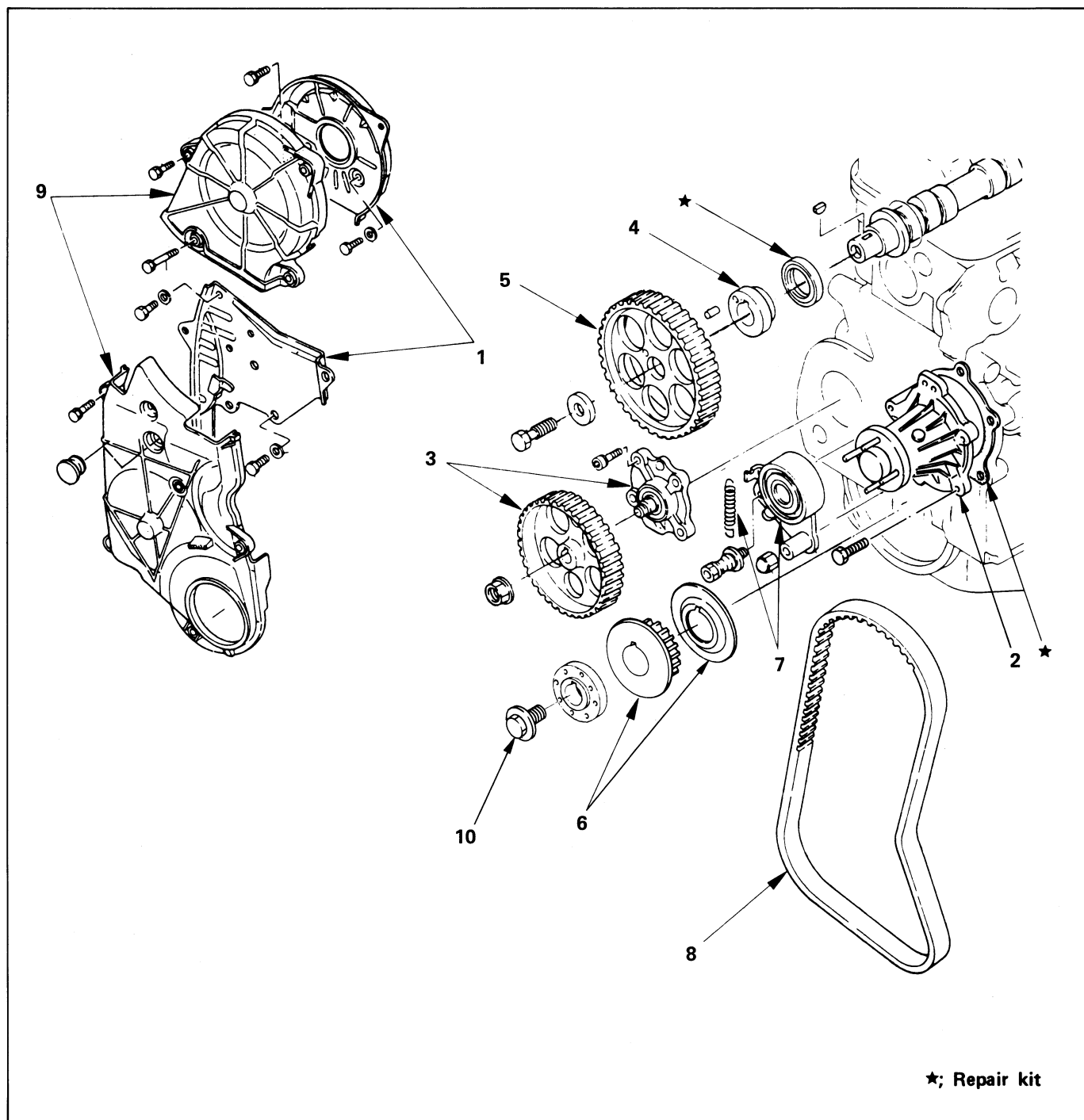

★; Repair kit

Reassembly steps

- |                             |   |
|-----------------------------|---|
| 1. Front plate              | A 6. Crankshaft timing pulley and guide plate |
| A 2. Water pump             | A 7. Tension pulley and tension spring        |
| A 3. Oil pump and pulley    | A 8. Timing belt                              |
| 4. Camshaft boss            | A 9. Timing belt cover                        |
| A 5. Camshaft timing pulley | A 10. Crankshaft pulley bolt                  |



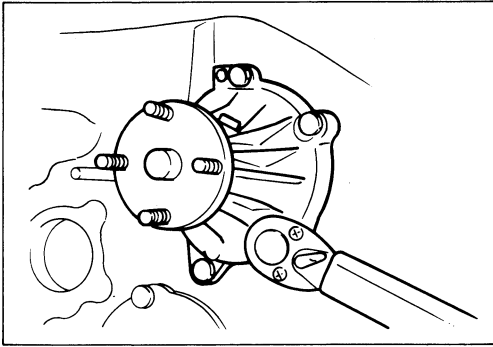

**2. Water pump**

Tighten the water pump assembly with predetermined torque.

Torque	kg-m(ft.lbs.)	1.4-2.4(10.1-17.4)
--------	---------------	--------------------

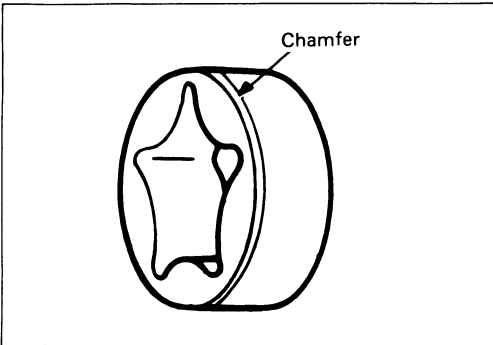

**3. Oil pump and pulley**

(1) Apply a generous amounts of engine oil to the rotor, then install the rotor with the chamfered side turned to the cylinder body.

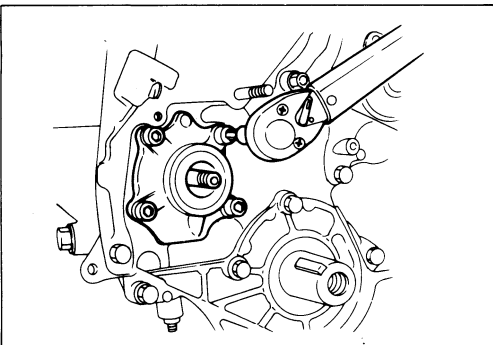

(2) Apply engine oil to the O-ring and insert it into the groove in the housing. Attach the rotor after applying generous amounts of engine oil.



Torque	kg-m(ftlbs.)	1.4-2.4(10.1-17.4)
--------	--------------	--------------------



Wrench ; inner hex = 6 mm

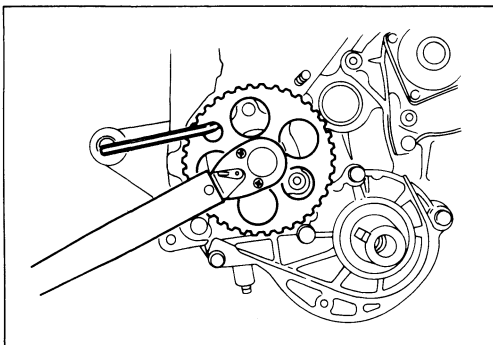

(3) Check if it turns smoothly. If not replace the cartridge assembly.

(4) Attach the pulley and tighten with predetermined torque.

Torque	kg-m(ft.lbs.)	6.7-8.7(48.4-62.9)
--------	---------------	--------------------

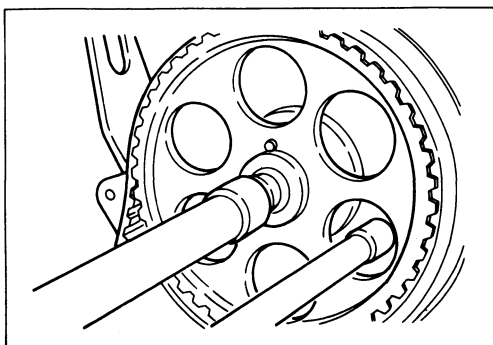

**5. Camshaft timing pulley**

Apply a detention to the pulley by putting a T-bar wrench or other proper tool over the front plate upper fitting bolt and tighten with predetermined torque.

Torque	kg-m(ftlbs.)	6.7-8.7(48.4-62.9)
--------	--------------	--------------------

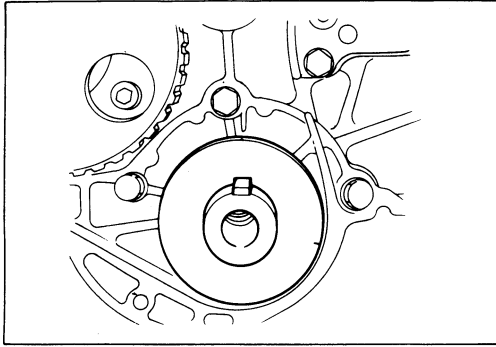

**6. Crankshaft timing pulley**

Attach the guide plate and assemble with the brim side of the timing pulley turned upward.

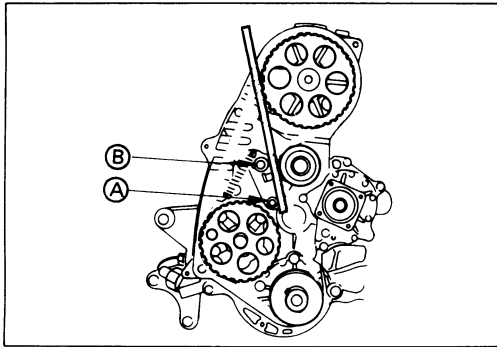

**7. Tension pulley and tension spring**

Insert the tension pulley into stud A, set the tension spring in plate, and temporarily tighten bolt B after pulling it fully to the water pump side.

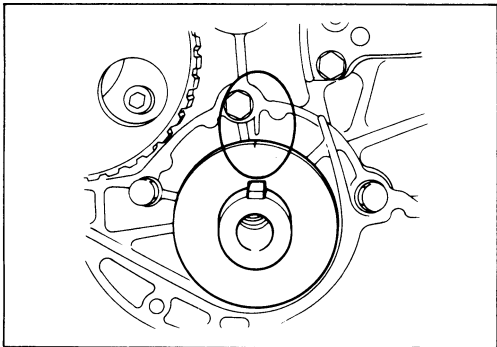

**8. Timing belt**

Install the timing belt in the sequence indicated below.

(1) Bring the matchmark of the crankshaft timing pulley into agreement with that of the front oil seal retainer.

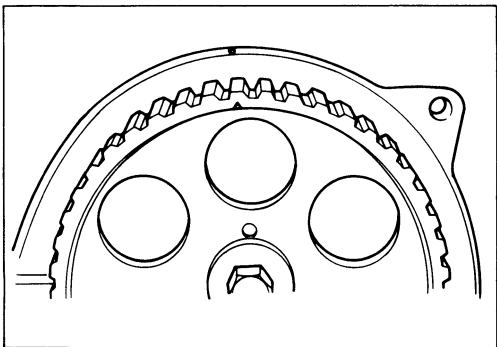

(2) Bring the matchmark of the camshaft timing pulley into agreement with that of the front plate. Keep the rocker arm altogether in a free state.



**Note:** At this point the No. 4 cylinder comes to its compression upper dead center.

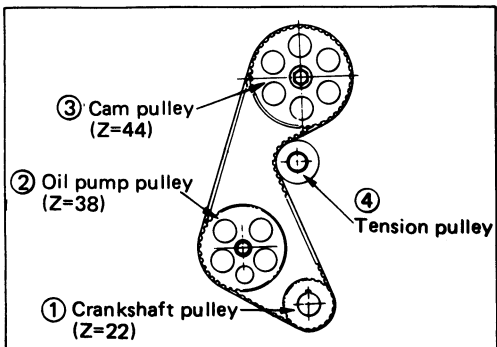

(3) Lay the timing belt over the crank pulley, oil pump pulley, cam pulley, and tension pulley in said order while avoiding loosening between them.

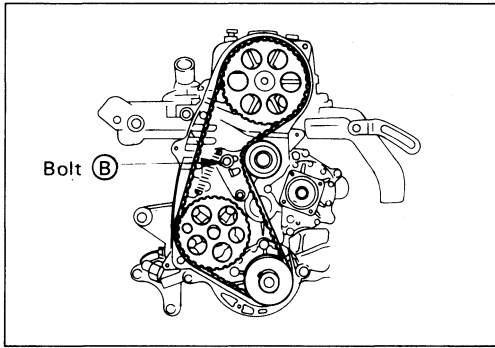

- (4) Loosen bolt B, tighten the belt by the force of the tension spring, and then tighten bolt B temporarily.

**Note:** At this point check if the matchmark of the crankshaft is in agreement with that of the camshaft timing pulley.

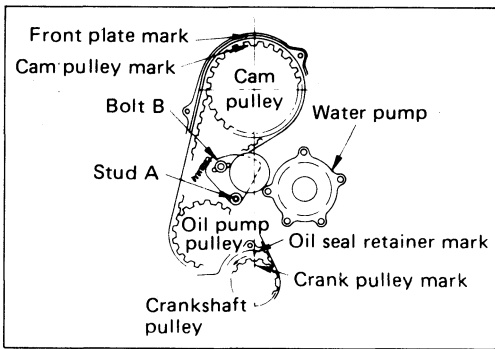

- (5) Temporarily attach the crank pulley. Turn the crankshaft two revolutions in the opposite direction of normal rotation to bring the crankshaft setting mark into agreement with the crankshaft pulley setting mark loosen bolt B and tighten the belt with the tension pulley. Tighten bolt B to the specified torque.

Torque	kg-m(ft.lbs.)	1.4-2.4(10.1-17.4)
--------	---------------	--------------------

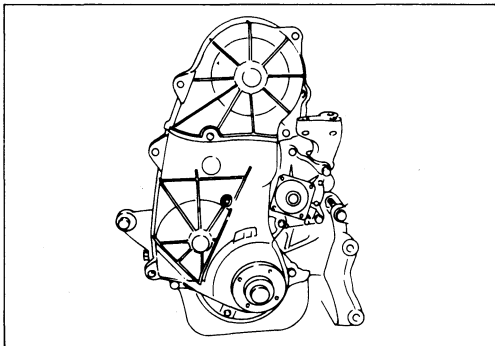

**9. Timing belt cover (upper and lower)**

Attach the timing belt cover and tighten with predetermined torque.

Torque	kg-m(ft.lbs.)	0.5-1.0(3.6-7.2)
--------	---------------	------------------

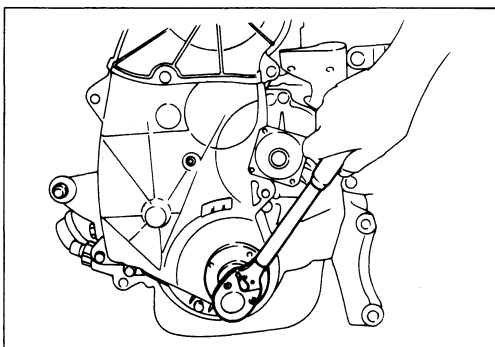

**10. Crankshaft pulley bolt**

Apply a detention to the crankshaft and tighten with predetermined torque.

Torque	kg-m(ft.lbs.)	10.5-13.5(75.9-97.6)
--------	---------------	----------------------

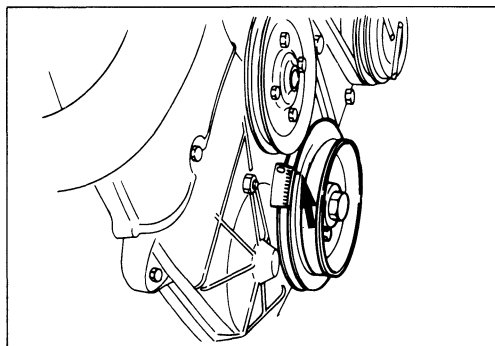

**Valve clearance adjustment**

Bring either the No. 1 or No. 4 piston to top dead center on the compression stroke. Do this by turning the crankshaft to align mark on crankshaft pulley with timing mark.



Hold crankshaft in above position and adjust clearance of the valves indicated.

# 01-60 4ZD1 GASOLINE ENGINE

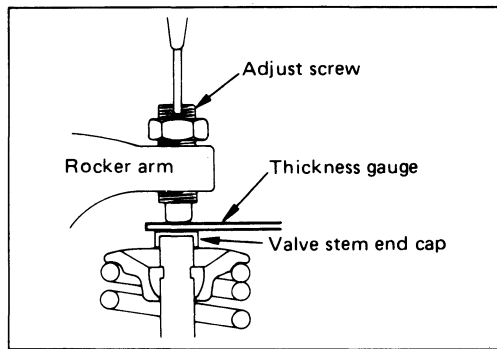

Adjust the valve clearance in the following manner using a feeler gauge.

	mm(in.)
Intake (cold)	0.15 (0.006)
Exhaust (cold)	0.25 (0.010)

Cylinder No.	1	2	3	4
Valve	1	2	3	4
Intake	○	○	•	•
Exhaust	○	•	○	•

**Note:** ○ When piston in No. 1 cylinder is at TDC on compression stroke.

- When piston in No. 4 cylinder is at TDC on compression stroke.

## EXTERNAL PARTS (Right hand side)

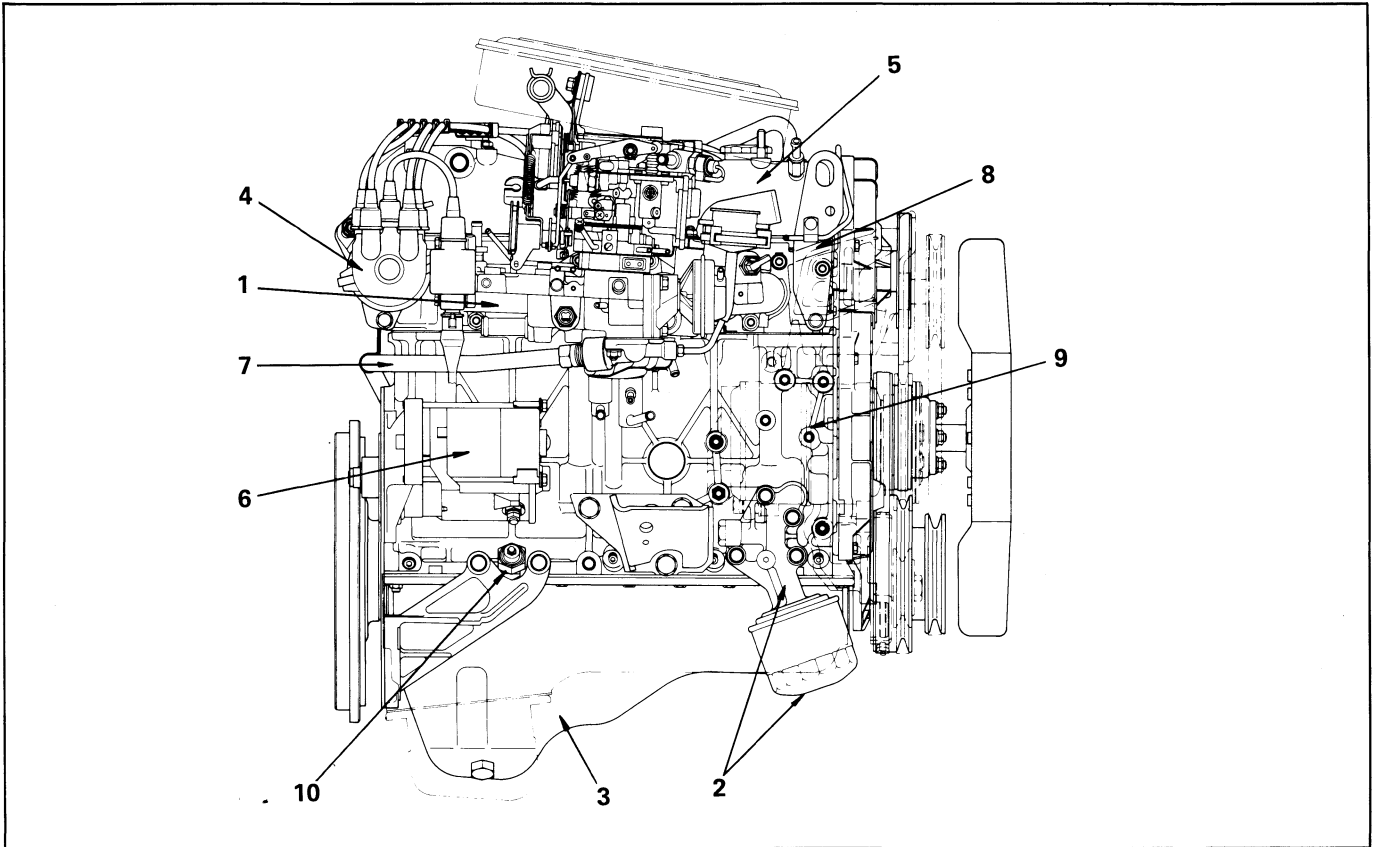

## Reassembly steps

- |                         |                                       |
|-------------------------|---------------------------------------|
| 1. Inlet manifold       | 6. Starter motor assembly             |
| 2. Oil filter and unit  | 7. EGR pipe                           |
| 3. Oil pan              | 8. Power steering pump and bracket    |
| 4. Distributor assembly | 9. Aircon compressor (If so equipped) |
| 5. Head cover           | 10. Oil pressure switch               |



**Important operations**

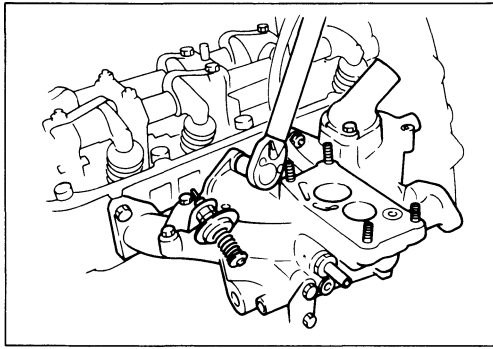

**1. Inlet manifold bolt**

Tighten the intake manifold with predetermined torque.

Torque	kg-m(ft.lbs.)	1.9-2.5(13.7-18.1)

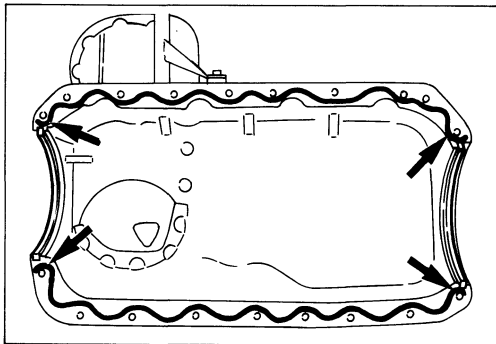

Be absolutely certain to apply an adequate amount of silicon gasket to the area indicated by the arrow in the illustration.

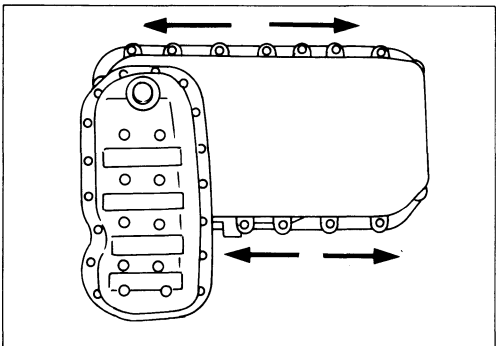

**3. Oil pan**

Install the bolts in sequence commencing with the bolts on center.

Torque	kg-m(ft.lbs.)	1.5—2.1(10.8—15.2)

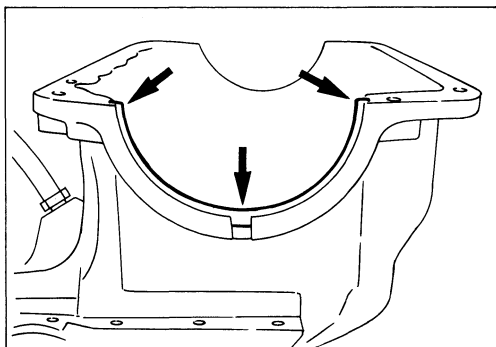

Carefully note the position of the crankcase front and rear arches.

Insert the packing.

Minimize the packing level as much as possible.

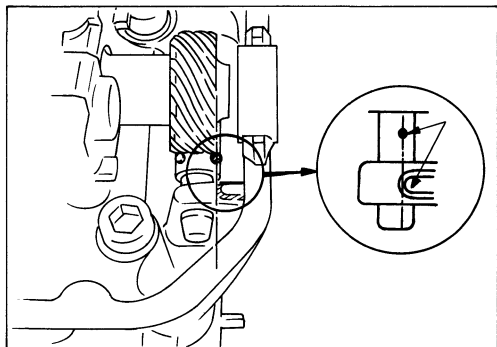

**4. Distributor**

- (1) Move the No. 4 piston (cylinder) to the top dead center position on the compression stroke.
- (2) Apply engine oil to the O-ring.
- (3) Check to see that the setting marks on the distributor shaft and the cylinder head are aligned.

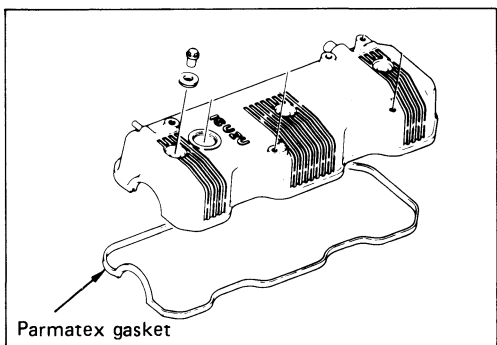

**5. Head cover**

Apply silicon gasket to the arched portion of the camshaft bearing cap.

Tighten the head cover with predetermined torque.

Torque	kg-m (ft. lbs.)	0.8-1.2(5.78-8.7)
--------	-----------------	-------------------

# 01-64 4ZD1 GASOLINE ENGINE

## EXTERNAL PARTS (Front and left hand side)

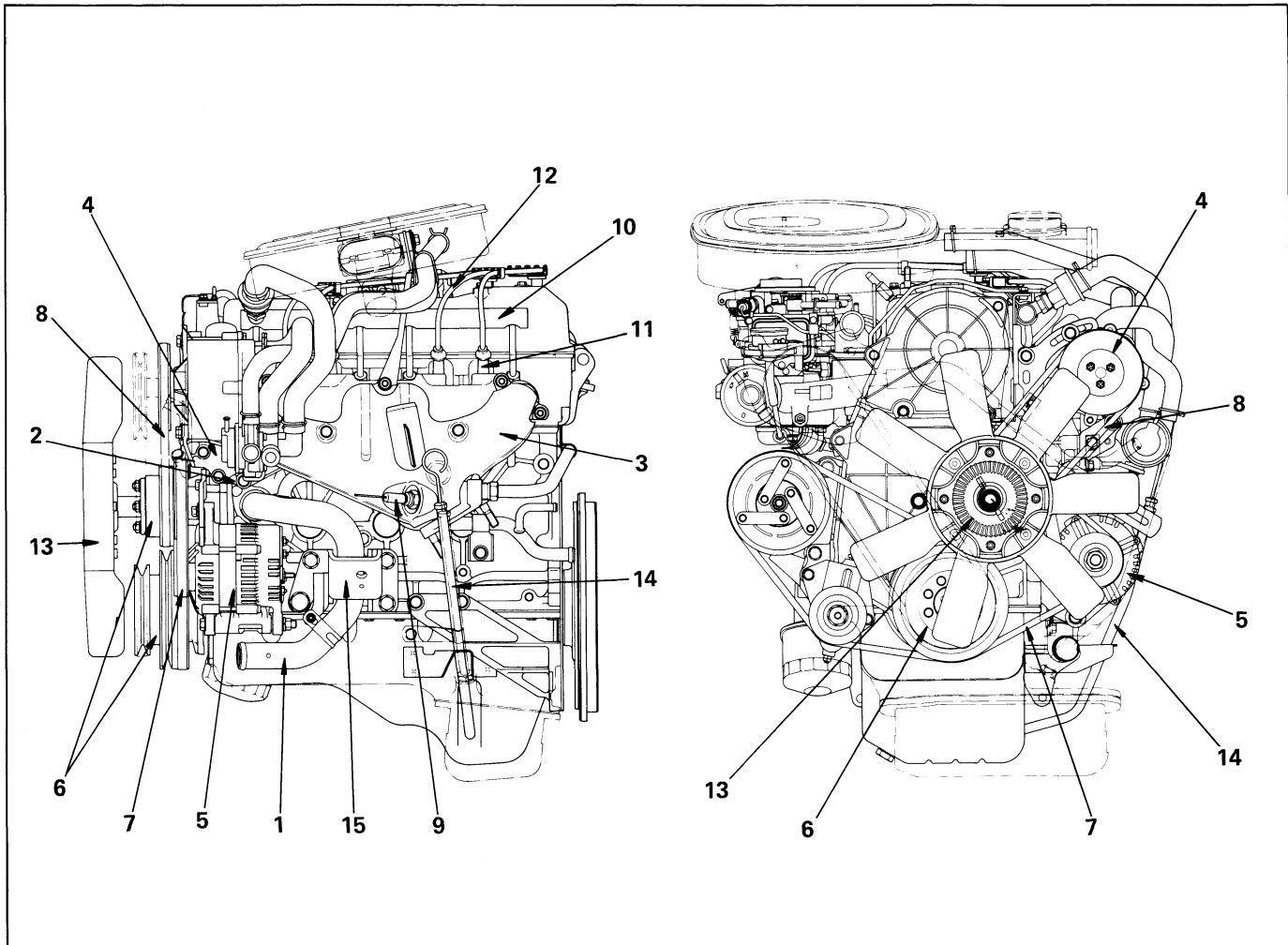

### Reassembly steps

1. Water inlet pipe
2. Air pump bracket "A"
- A 3. Exhaust manifold
4. Air pump and bracket "B"
5. Generator and bracket
6. Crankshaft pulley and water pump pulley
7. V-belt generator
8. V-belt air pump
- 9. O<sub>2</sub> Sensor (California only)
10. Air injection manifold
11. Spark plug
12. High-tension cord
13. Fan and clutch assembly
14. Oil level gauge
15. Engine mounting bracket





**Important operation**

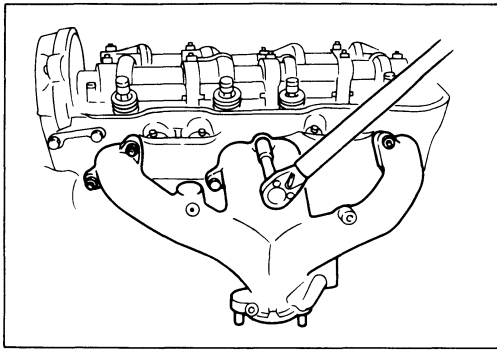

**3. Exhaust manifold**

Tighten the exhaust manifold with predetermined torque.

Torque	kg-m(ftlbs.)	1.9-2.5(13.7-18.1)
--------	--------------	--------------------

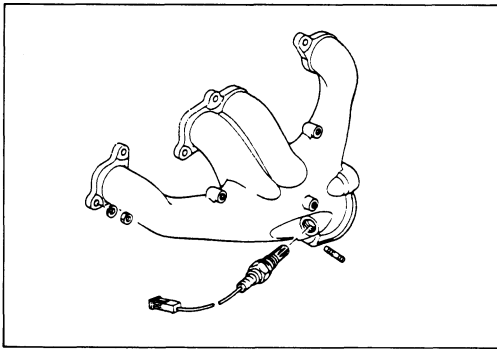

**9. O<sub>2</sub> Sensor (California)**

Apply rubber sealant to the threads before installation.

Torque	kg-m(ft.lbs.)	3.9-4.7 (28.2-34.0)
--------	---------------	---------------------

## OIL PUMP



### DISASSEMBLY

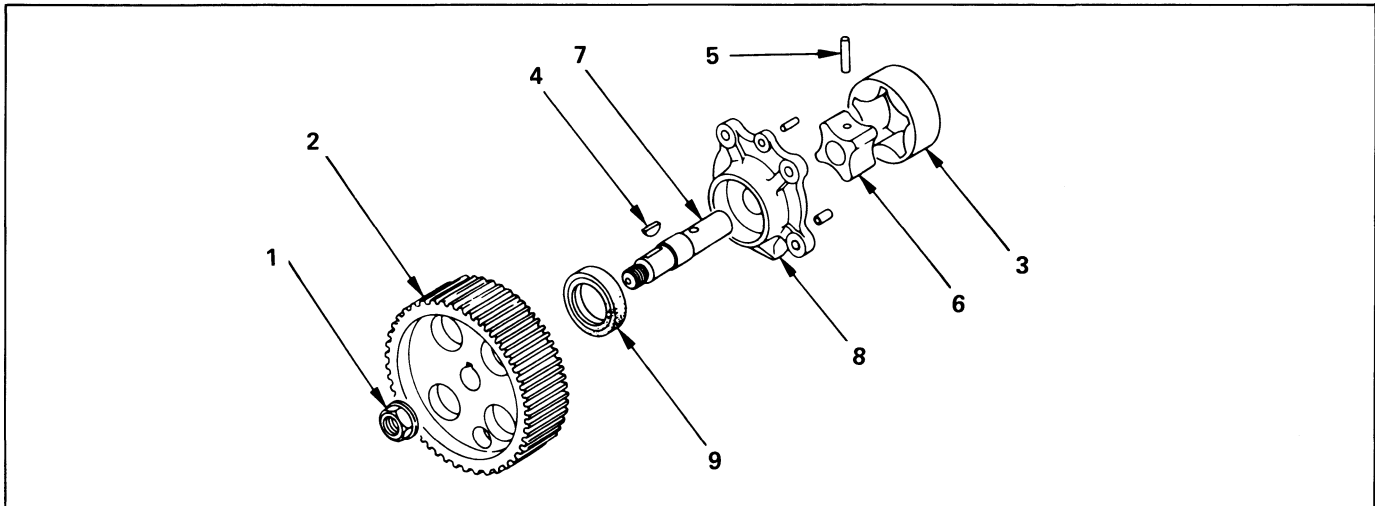

#### Disassembly steps

- |                      |                |
|----------------------|----------------|
| 1. Nut               | 6. Inner rotor |
| 2. Oil pump pulley   | 7. Shaft       |
| 3. Outer rotor       | 8. Housing     |
| 4. Key               | 9. Oil seal    |
| 5. Pin (Shaft-Rotor) |                |



**INSPECTION AND REPAIR**

Make necessary correction or parts replacement if wear, damage or any other abnormal condition are found through inspection.

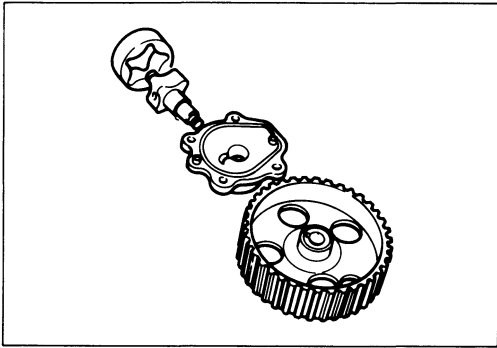

Visually inspect the disassembled parts for wear, damage, or other abnormal conditions.

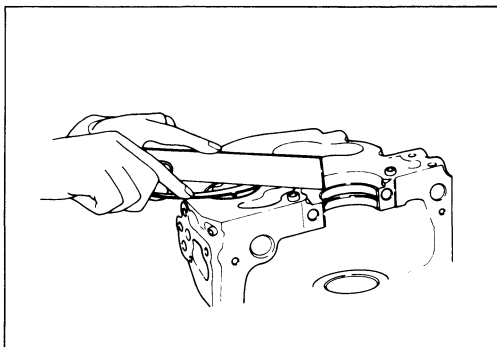

Insert the vane into the cylinder body and measure the top clearance.

mm(in.)	
Standard	Limit
0.04 - 0.09 (0.002 - 0.004)	0.15 (0.006)

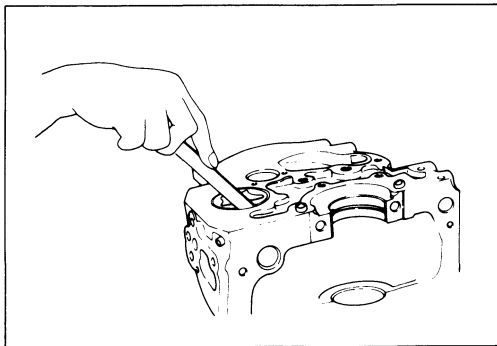

Measure the clearance between the slide surfaces of the outer rotor and the cylinder body.

mm(in.)	
Standard	Limit
0.24 - 0.36 (0.009 - 0.014)	0.4 (0.016)

# 01-68 4ZD1 GASOLINE ENGINE

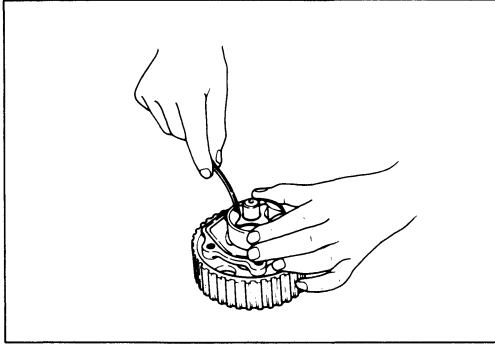

Clearance between the outer rotor and the inner rotor

mm(in.)

Standard	Limit
0.13 - 0.15 (0.005 - 0.006)	0.2 (0.008)



## REASSEMBLY

To assemble, follow the disassembly procedure in reverse order.

## WATER PUMP



### REMOVAL AND INSTALLATION

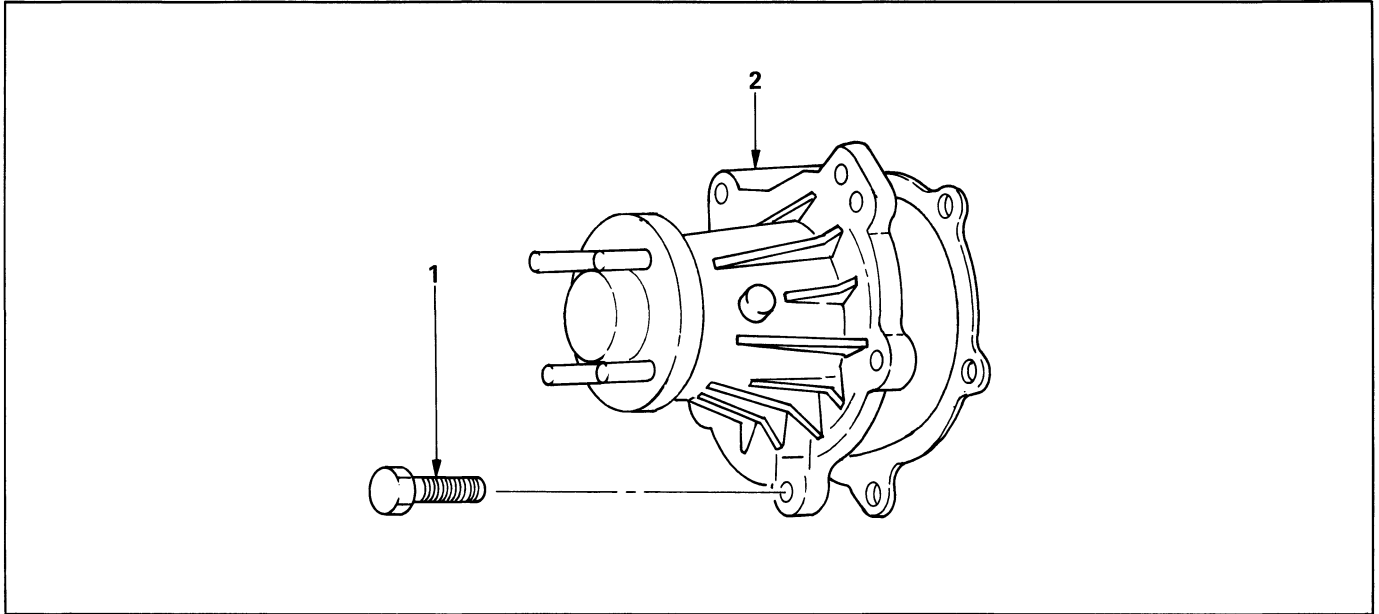

#### Removal steps

1. Bolts
2. Water pump assembly

#### Installation steps

2. Water pump assembly
1. Bolts



## INSPECTION AND REPAIR

Make necessary correction or parts replacement if wear, damage or any other abnormal conditions are found through inspection.



### Visual check

Should any of the following problems occur, the entire water pump should be replaced as a unit.

1. Cracks in the water pump body
2. Water leakage from the seal unit
3. Play or abnormal noise in the bearing
4. Cracks or corrosion in the impeller



### Important operation — Installation

#### 1. Bolt

Tighten the water pump assembly with predetermined torque.

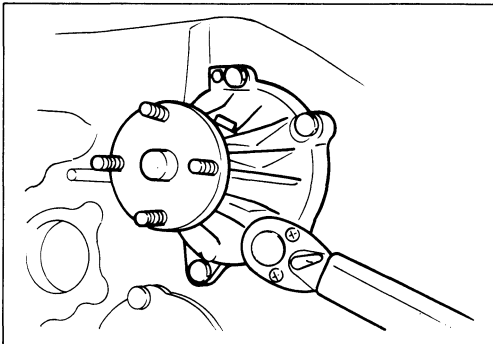

Torque	kg-m(ft.lbs.)	1.4-2.4 (10.1-17.4)

# RADIATOR



## REMOVAL AND INSTALLATION

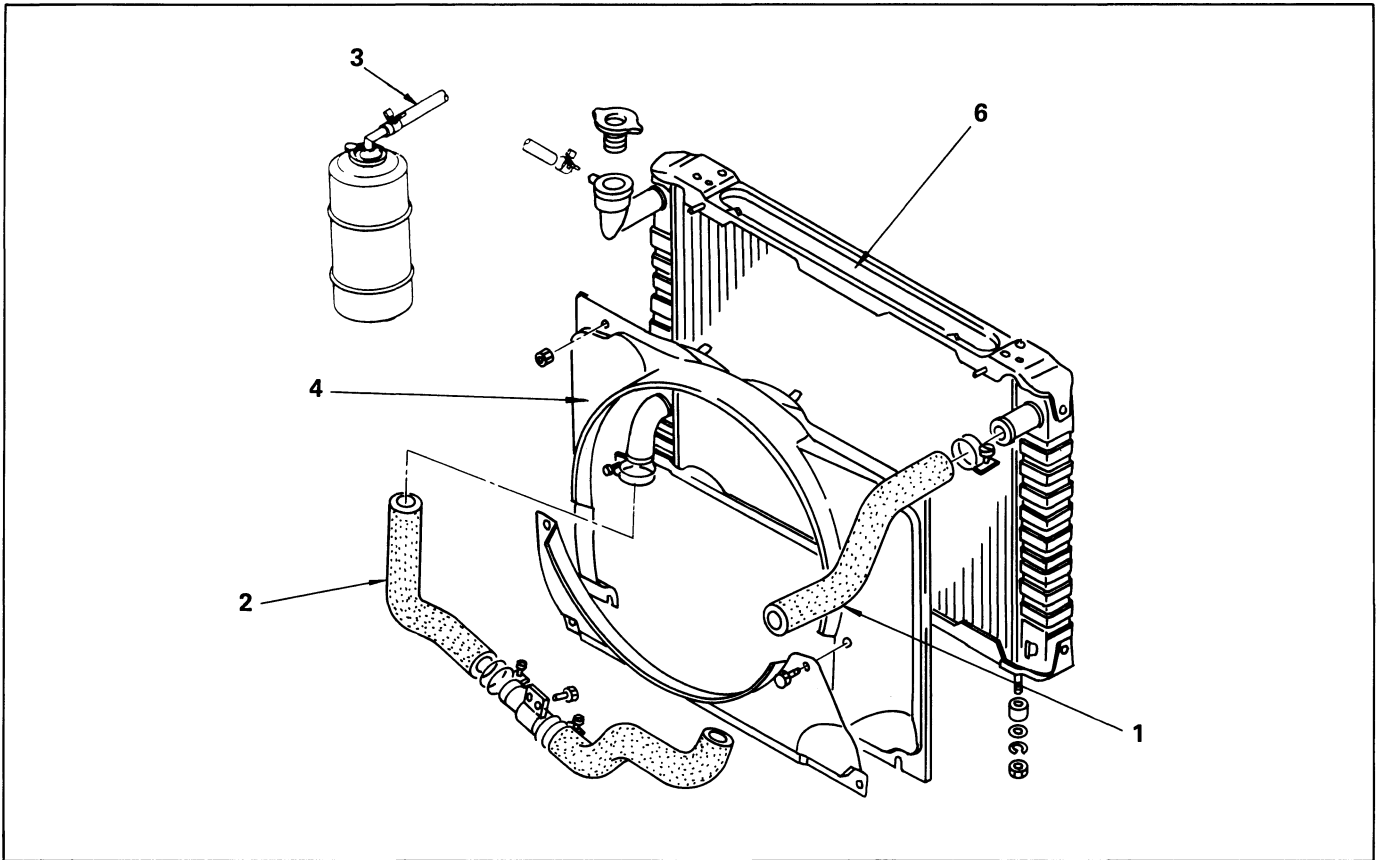

### Removal steps

1. Top hose
2. Bottom hose
3. Hose ; surge tank
4. Fan shroud
5. Stay
6. Radiator assembly

### Installation steps

To install, follow the removal procedure in reverse order.



## INSPECTION AND REPAIR

Make necessary adjustments, repairs, and part replacements if wear, damage, or other problems are discovered during inspection.

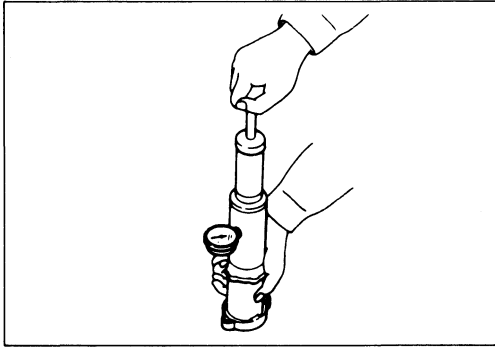

## (1) Radiator filler cap

Check the filler cap pressure valve opening pressure using a radiator filler cap tester. If the measurement deviates from the specified range, replace the cap assembly with a new one.



Cap tester : J24460-01

Pressure valve kg/cm <sup>2</sup> (lb/in <sup>2</sup> )(psi)	0.8 - 1.2 (12.8 - 17.1)
---	-------------------------

Check the condition of the vacuum valve at the center part of the valve seat on the filler cap. Replace the cap with a new one if it is found to be rusted or fouled.

Negative pressure valve kg/cm <sup>2</sup> (psi)	0.04 - 0.05 (0.6 - 0.7)
---	-------------------------

Check to see if the vacuum valve can be operated smoothly by hand. Clean or replace the valve with a new one if necessary.

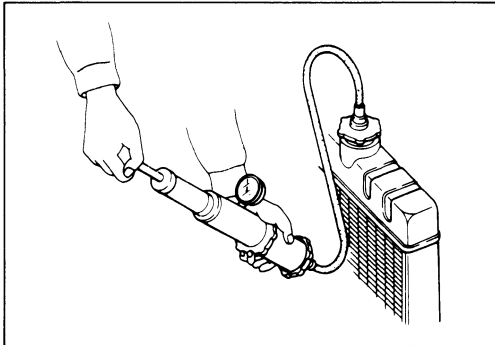

## (2) Inspection of the radiator for leakage

Check the cooling system for leakage at the following points by applying a pressure of 2 kg/cm<sup>2</sup> (28.5 psi) with a cap tester:

- Leakage from the radiator
- Leakage from the water pump
- Leakage from the water hoses
- Check the rubber hoses for swelling.



Cap tester : J-24460-01



## (3) Radiator core

Thoroughly clean the radiator core to remove deposits of foreign matter from the front face and from between the cooling fins.

If the cooling fins are found to be distorted, make corrections taking care not to damage the joining portions between the fins and the water tubes.



## (4) Water hoses

Check the top and bottom hoses for deterioration, swelling, or damage, and replace with new ones as necessary.



## THERMOSTAT



### REMOVAL AND INSTALLATION

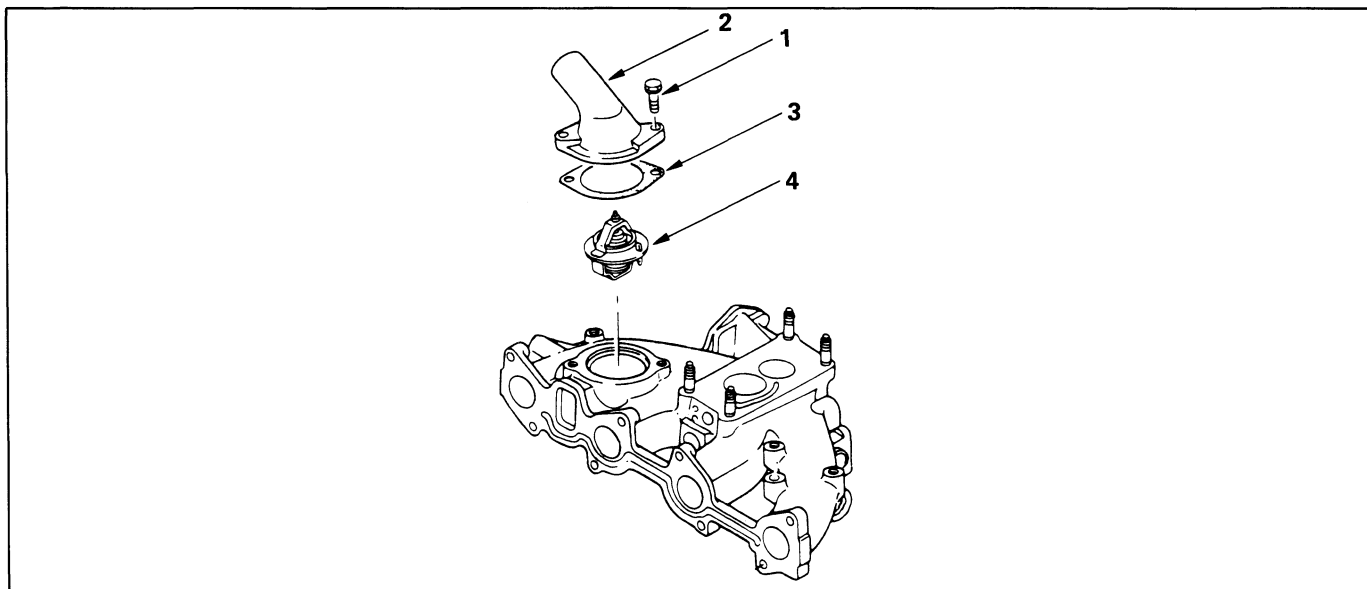

#### Removal steps

1. Bolts
2. Water outlet pipe
3. Outlet pipe packing
4. Thermostat

#### Installation steps

4. Thermostat
3. Outlet pipe packing
2. Water outlet pipe
1. Bolts



**Important operation — Installation**

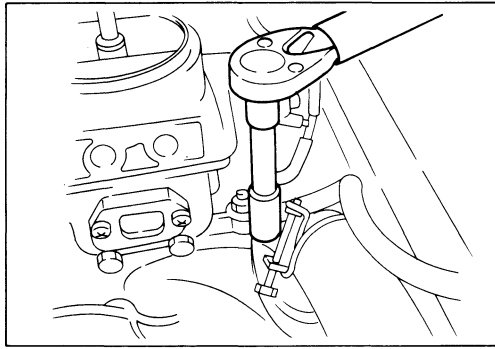

**1. Bolts**

Tighten the water pump assembly with predetermined torque.

Torque	kg-m(ft.lbs.)	1.4-2.4 (10.1-17.4)
--------	---------------	---------------------



**INSPECTION AND REPAIR**

Make necessary correction or parts replacement if wear, damage or any other abnormal conditions are found through inspection.

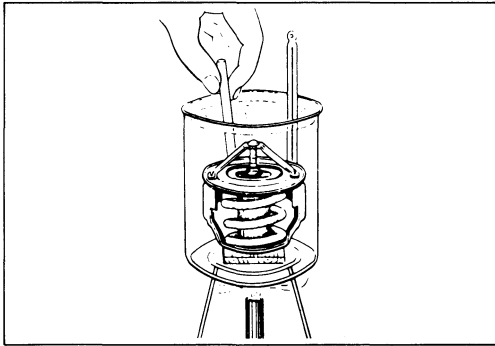

Submerge the thermostat assembly in water. Gradually increase the temperature of the water. Observe and record the temperature of the water at the time the valve first begins to open. Then observe and record the temperature at which the valve becomes fully open.

Valve opening temperature	80.5 - 83°C
Valve lift	8 mm or more at 95°C



- Note:**
- 1) It should take from three to five minutes for the valve to first begin to open, depending on the initial temperature of the water.
  - 2) Do not directly apply heat to the thermostat during this procedure.  
Place wooden blocks at the bottom of the hot water container or suspend the thermostat with wire or rope into the container.
  - 3) Frequently stir the hot water to ensure that the temperature is constant throughout the container.

# DIAGNOSIS

## HARD STARTING

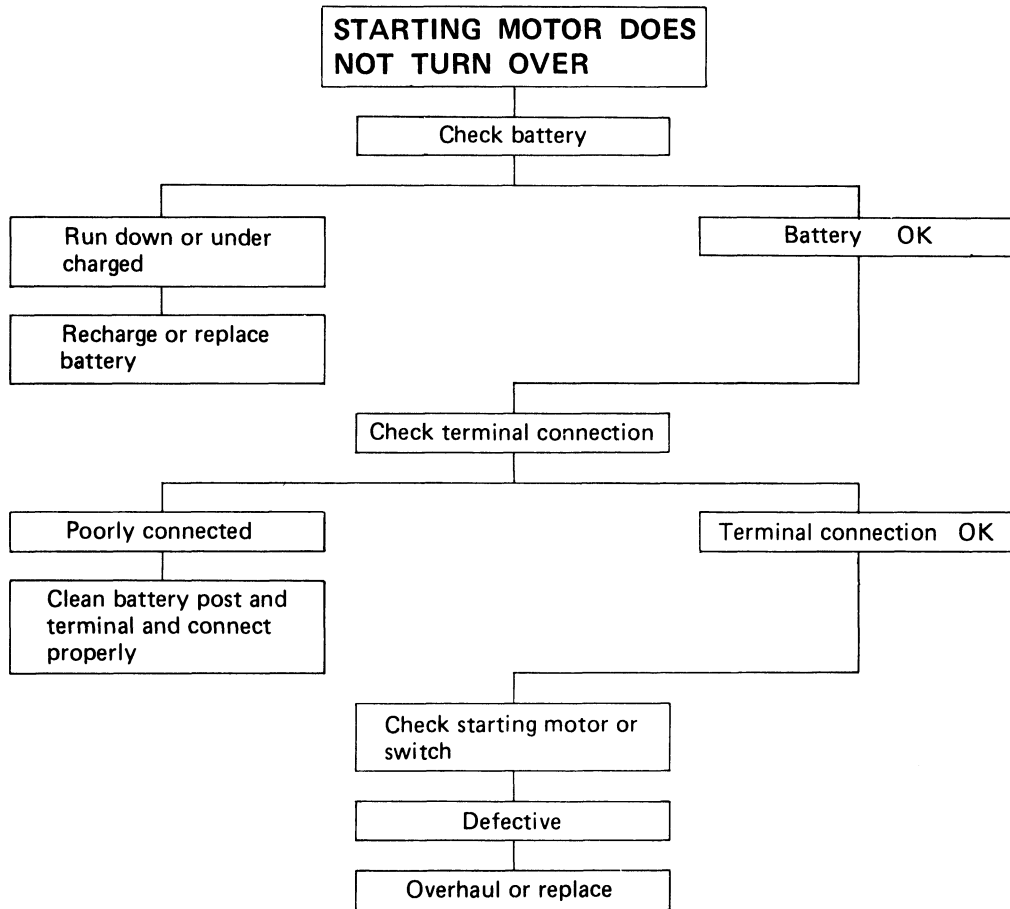

### Troubleshooting Procedure

Turn on headlights and starter switch.

Headlights go out or dim considerably.	<ul style="list-style-type: none"> <li>a) Battery undercharged,</li> <li>b) Starting motor coil circuit shorted,</li> <li>c) Starting motor parts defective.</li> </ul>
Headlights stay bright	<ul style="list-style-type: none"> <li>a) Starting motor circuit open,</li> <li>b) Starting motor coil open,</li> <li>c) Starting switch defective.</li> </ul>

01-76 4ZD1 GASOLINE ENGINE

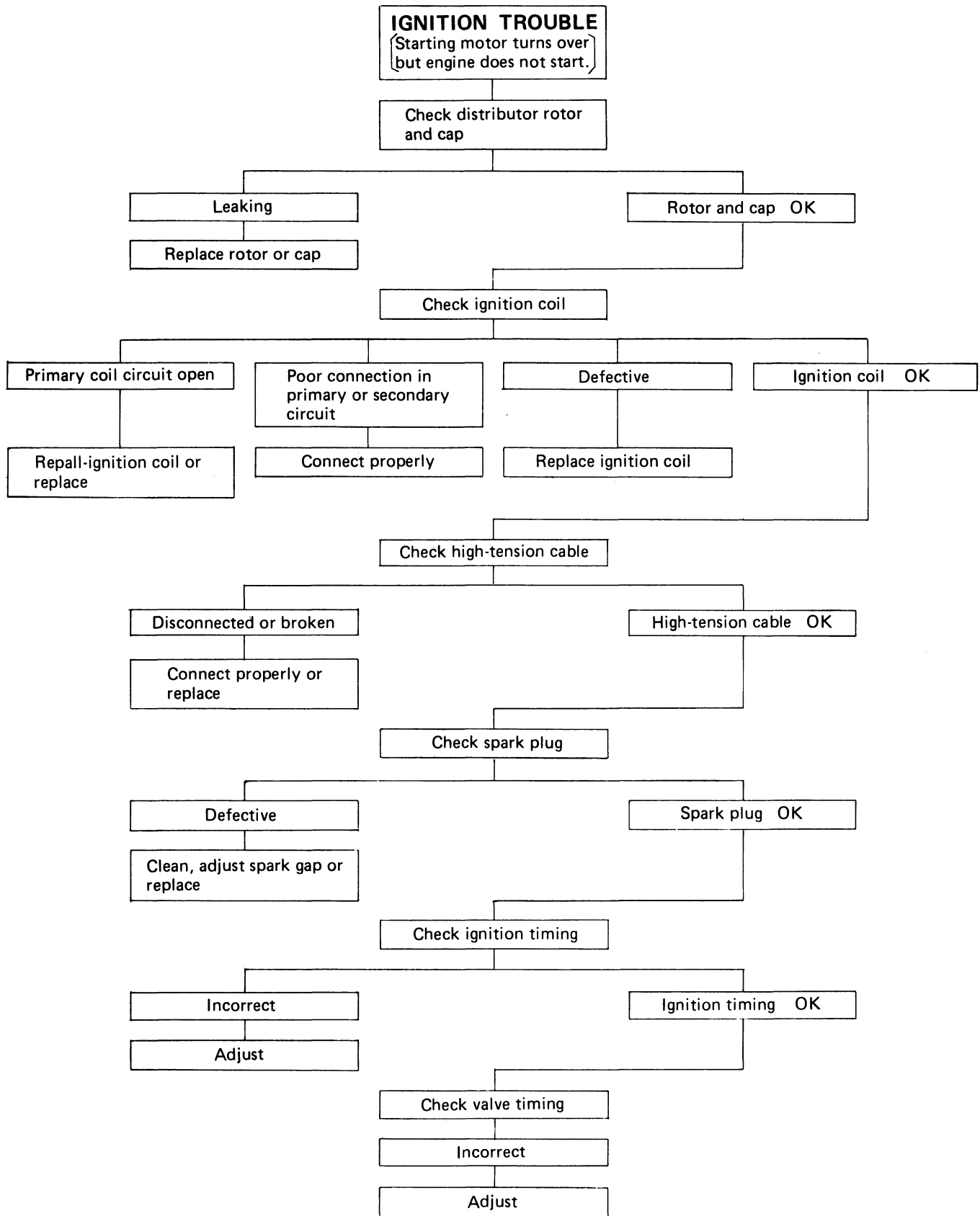

**Spark Test**

Remove the high-tension cable from any spark plug. Hold the end of the high-tension cable close to the engine block and while cranking engine, check to see if a spark jumps across the gap.

Be sure to cover the high-tension cable with dry paper, or some other good insulating material to prevent shock before cranking the engine.

Spark jumps across the gap.	a) Ignition timing incorrect, b) Spark plug defective, c) Fuel not reaching carburetor or engine, d) Engine lacks compression.
No sparking takes place.	a) Primary coil circuit shorting, b) Distributor air gap incorrect, c) Distributor points burned, d) Primary coil circuit open or loosely connected.

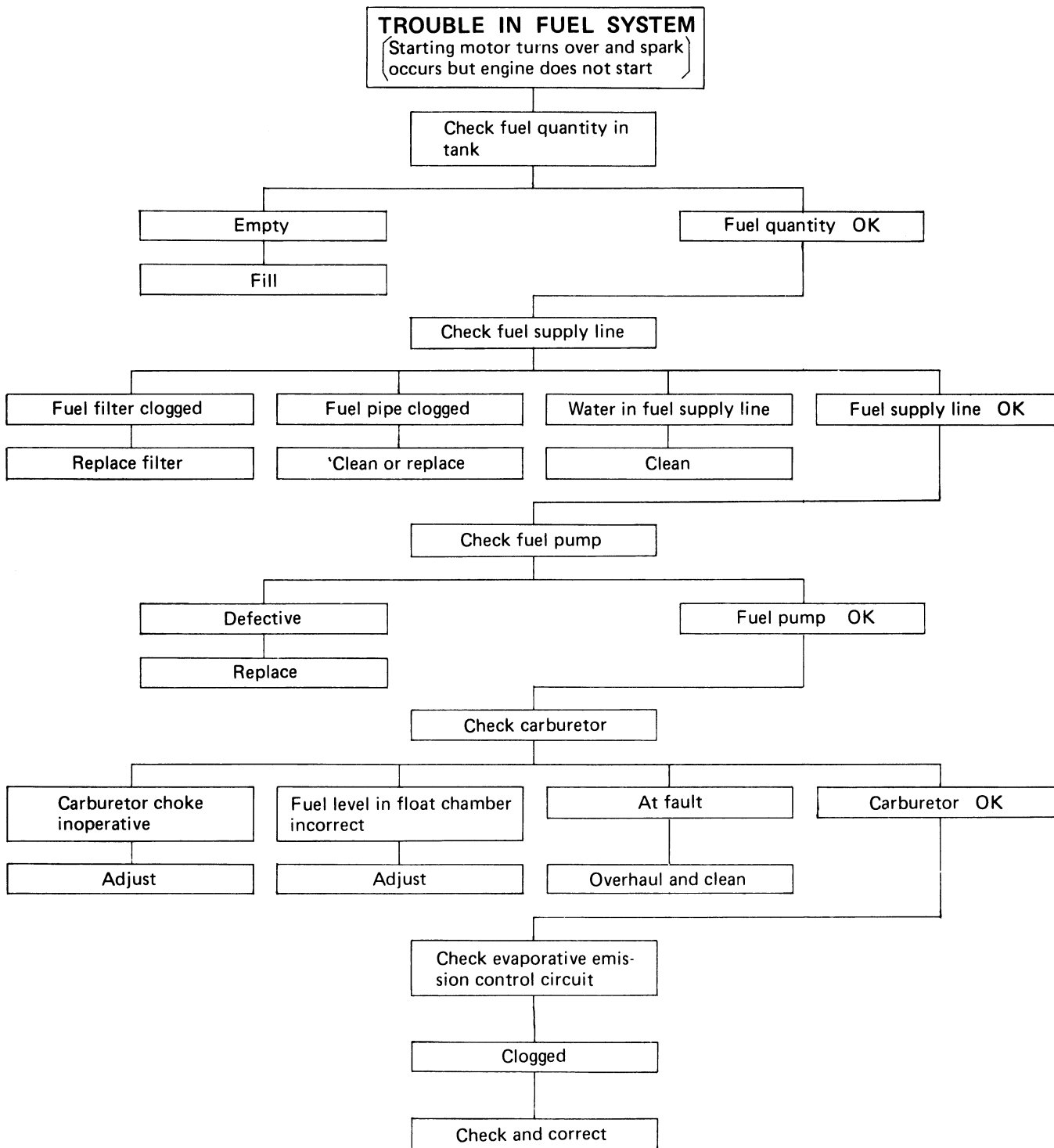

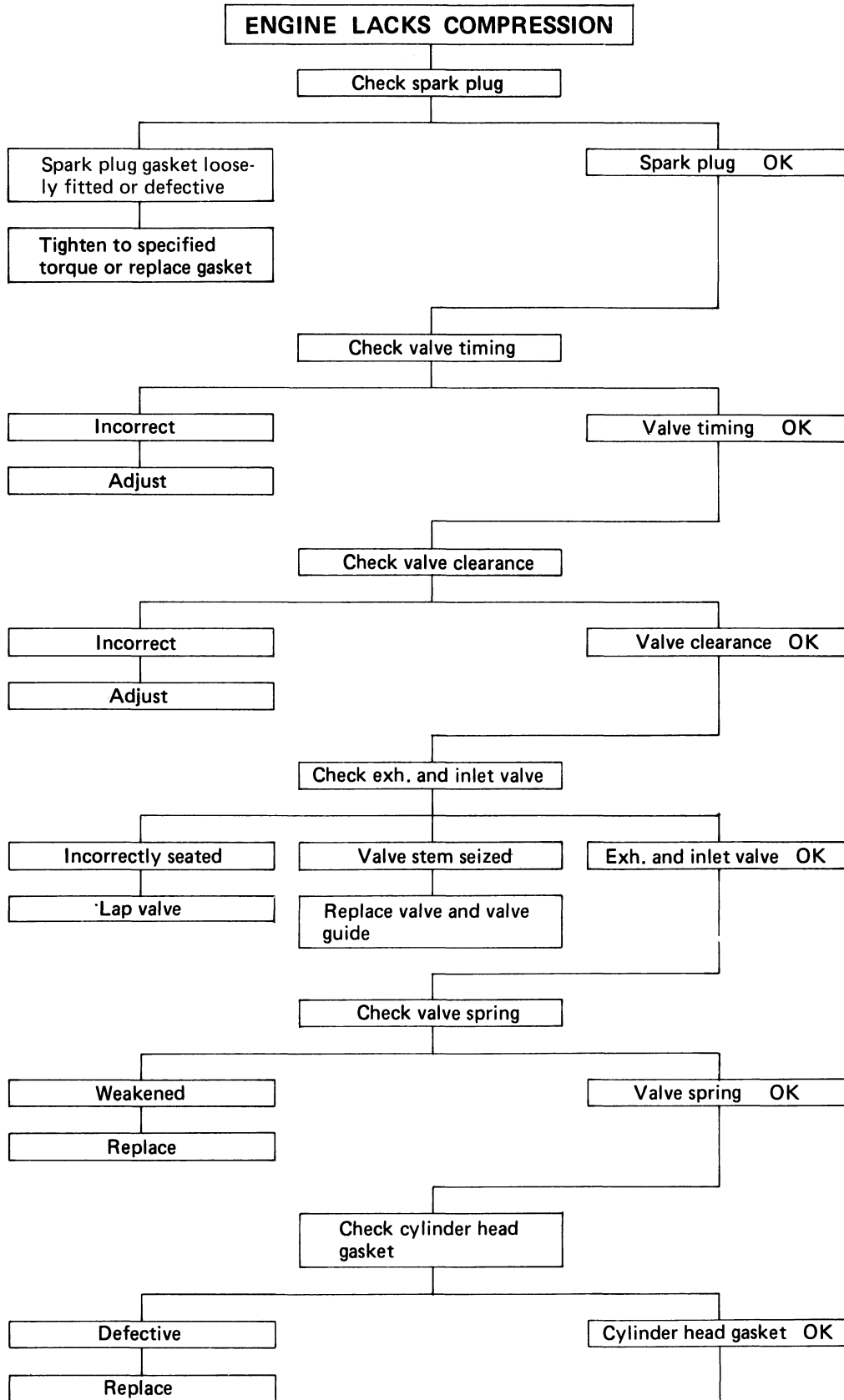

Continued on next page

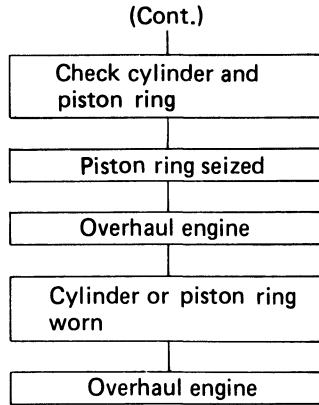

**Trouble Shooting Procedure**

- a) Start and warm up the engine. Remove all spark plugs and apply a few drops of engine oil to the spark plug holes.
- b) Connect a tachometer and crank the engine, checking that the cranking speed is 300 rpm or higher.
- c) Press the adapter of the cylinder compression gauge onto a spark plug hole hard enough to prevent air leakage.  
Crank the engine with the throttle valve wide open and take the highest reading of the compression gauge.
- d) Note the reading of the tachometer and the compression gauge.
- e) Check the compression in each cylinder by repeating the above procedure. If the variation between cylinders is more than 0.6 kg/cm<sup>2</sup> (8.53 psi.), perform a cylinder leakage test to determine the cause.





ROUGH ENGINE IDLING

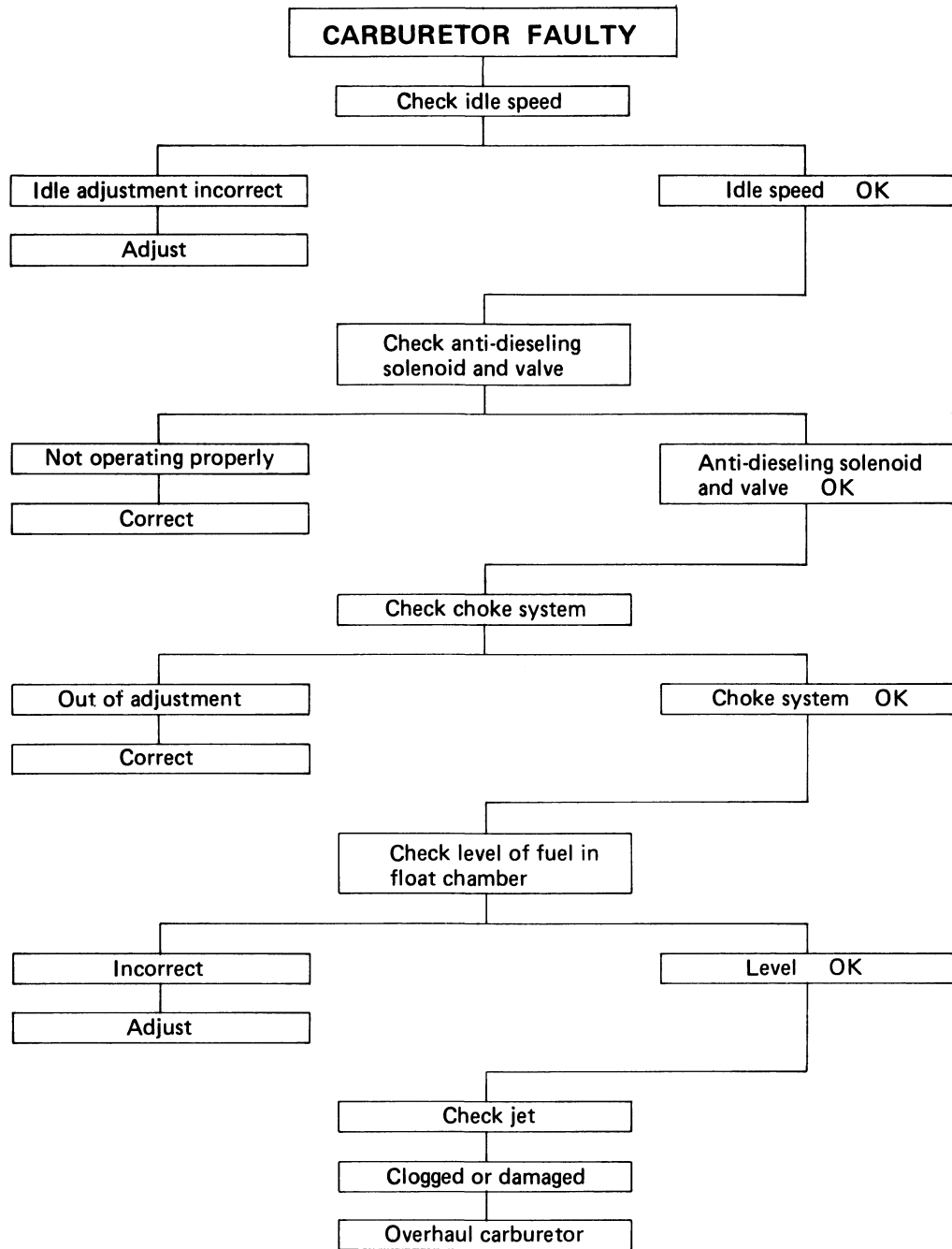

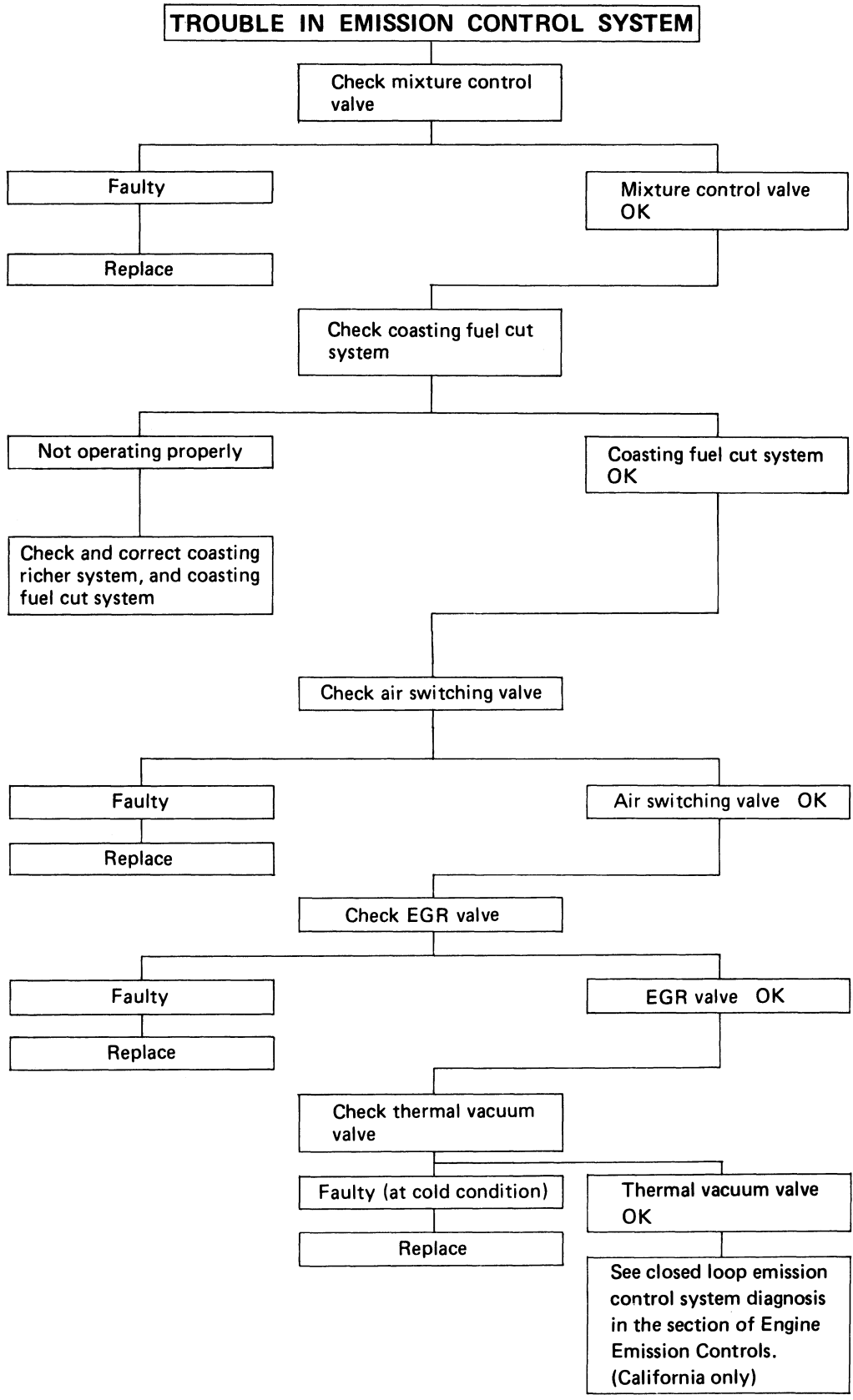

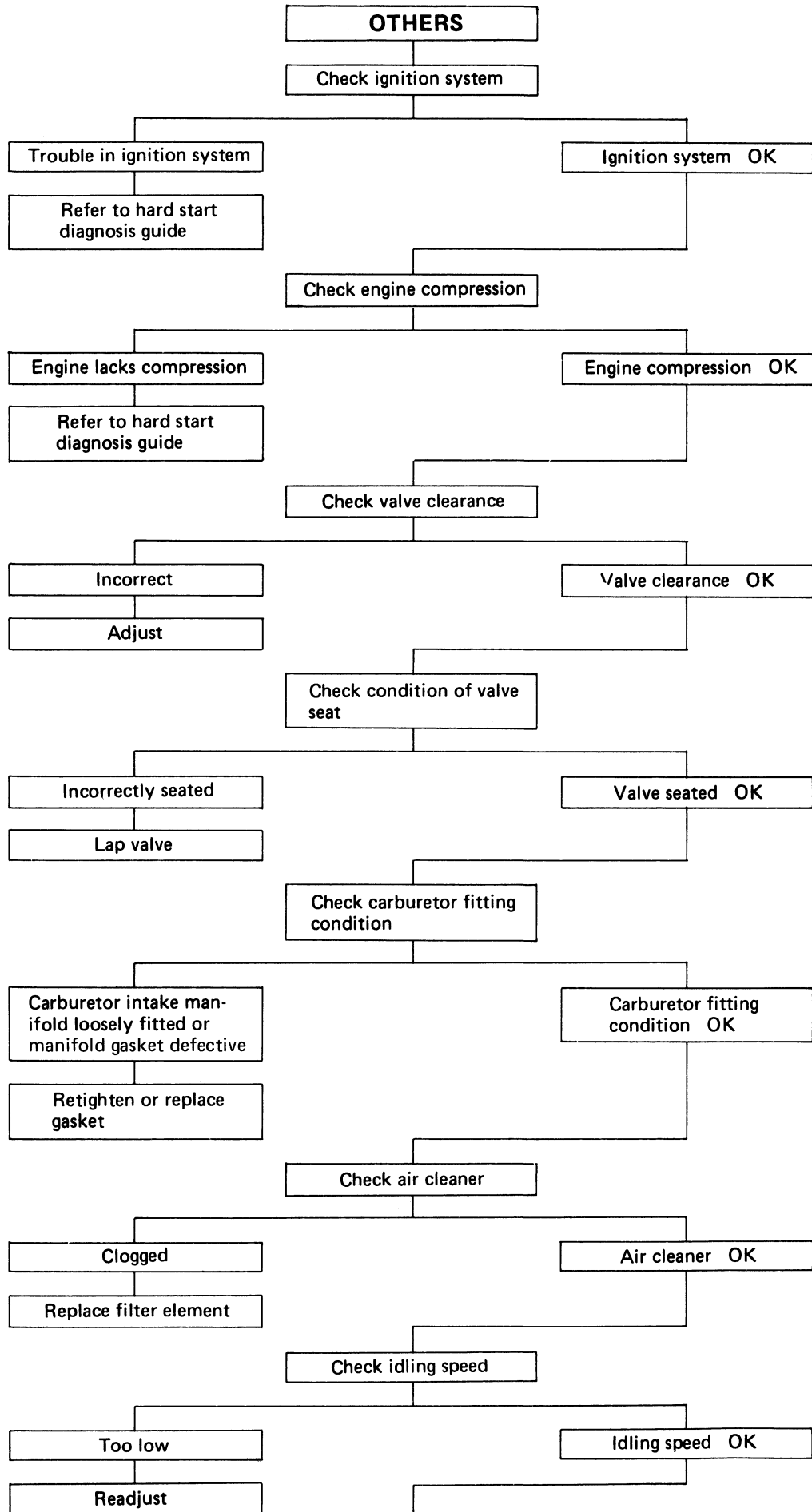

Continued on next page

01-84 4ZD1 GASOLINE ENGINE

(Cont.)

Check camshaft timing

Incorrect

Readjust

ENGINE LACKS POWER

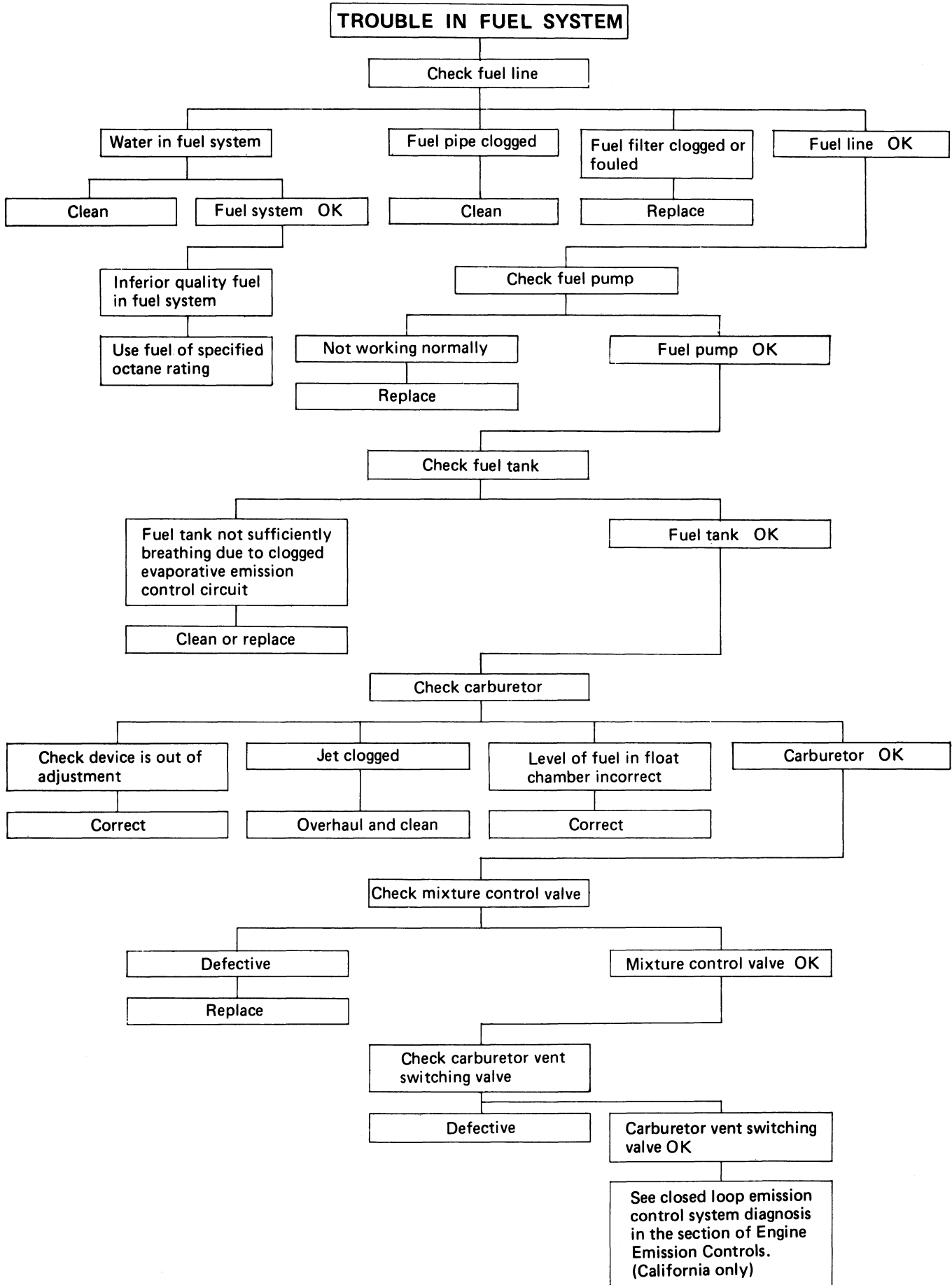

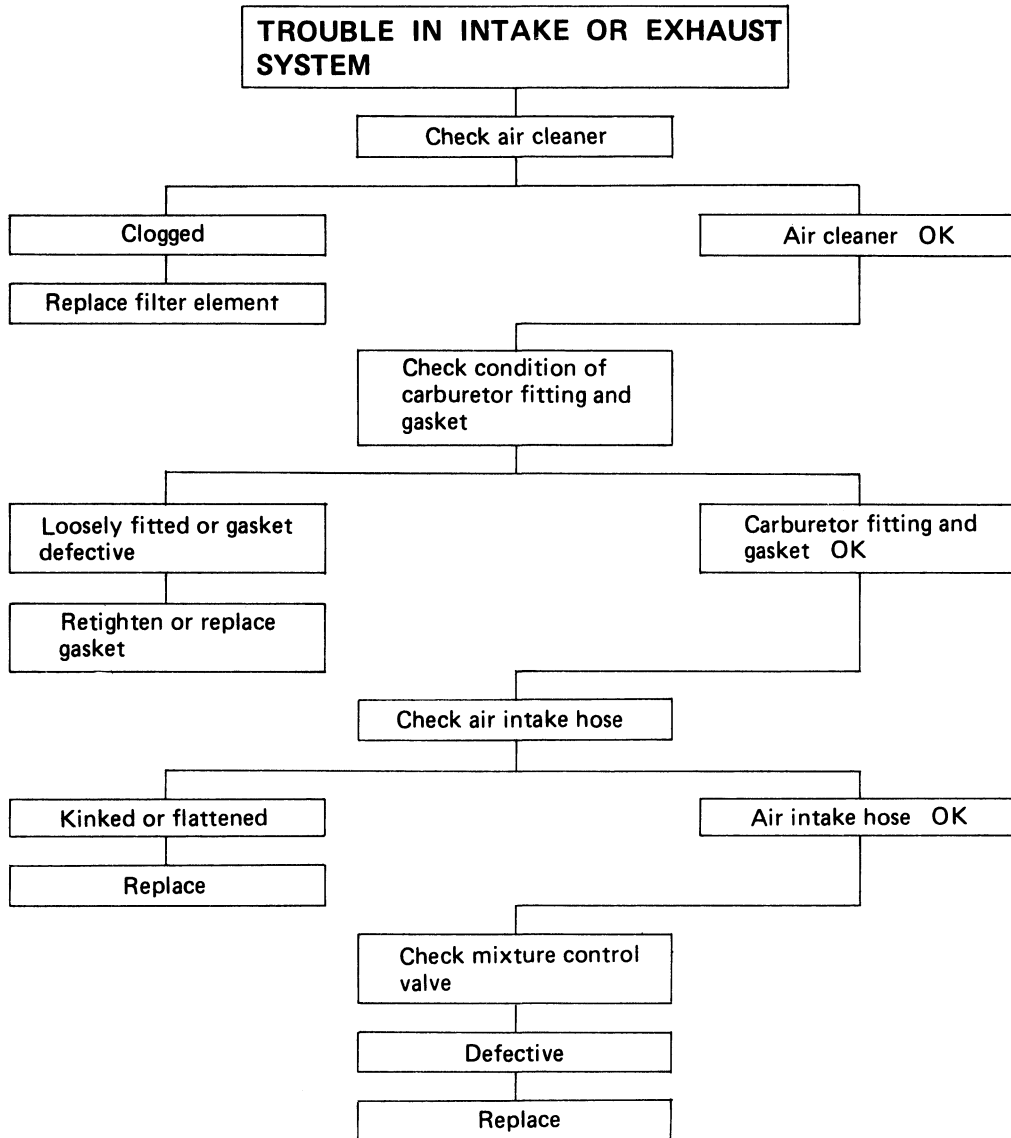

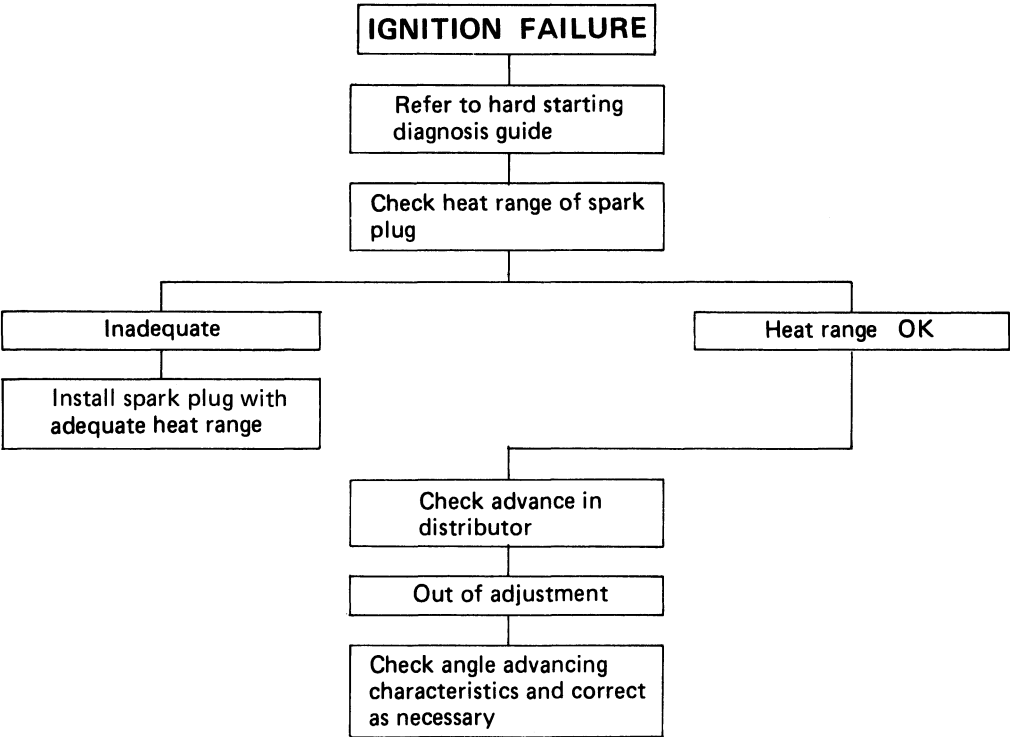

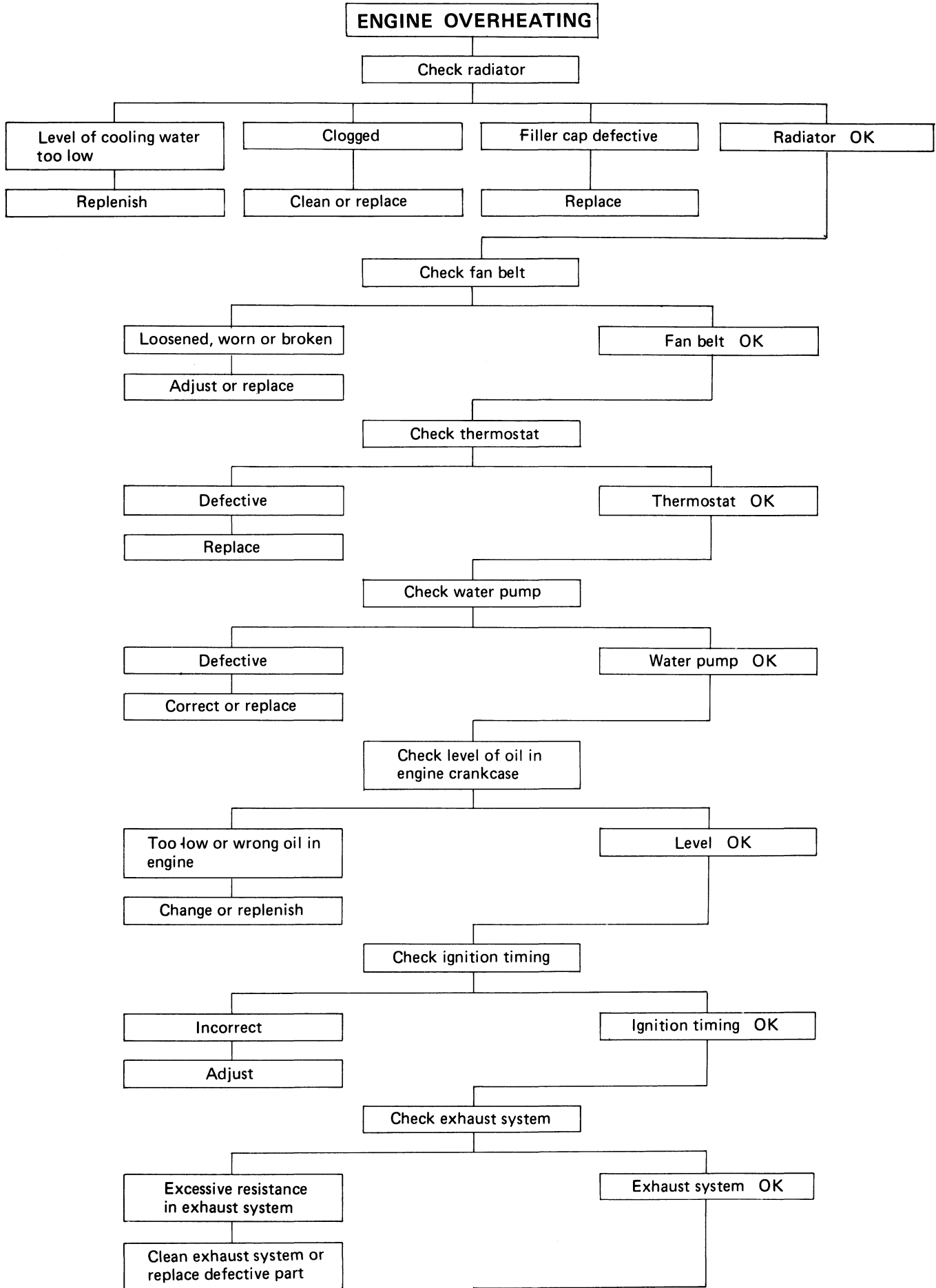

Continued on next page



(Cont.)

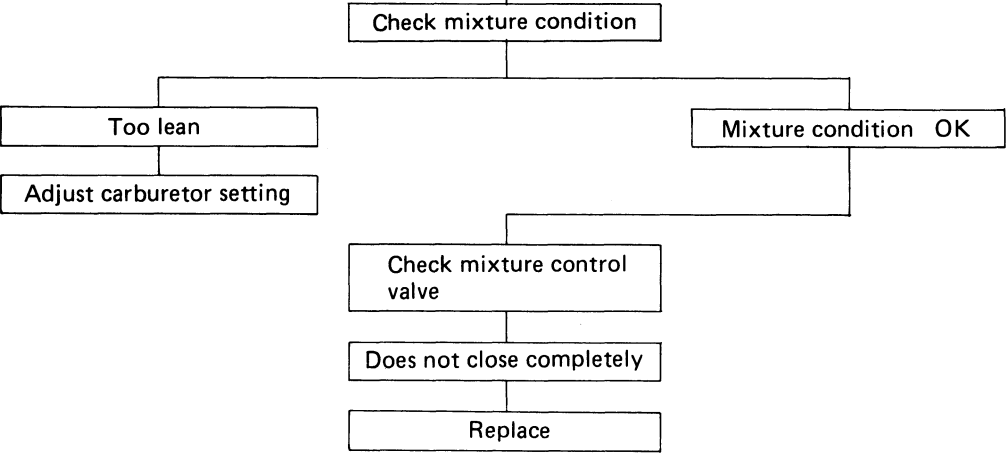

**ENGINE OVERCOOLING**

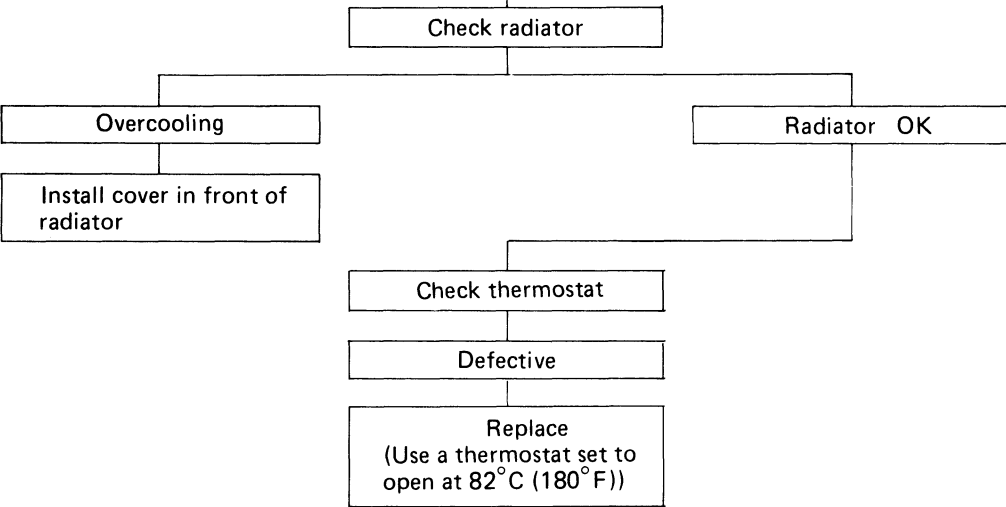

**ENGINE LACKS COMPRESSION**

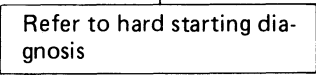

ENGINE NOISY

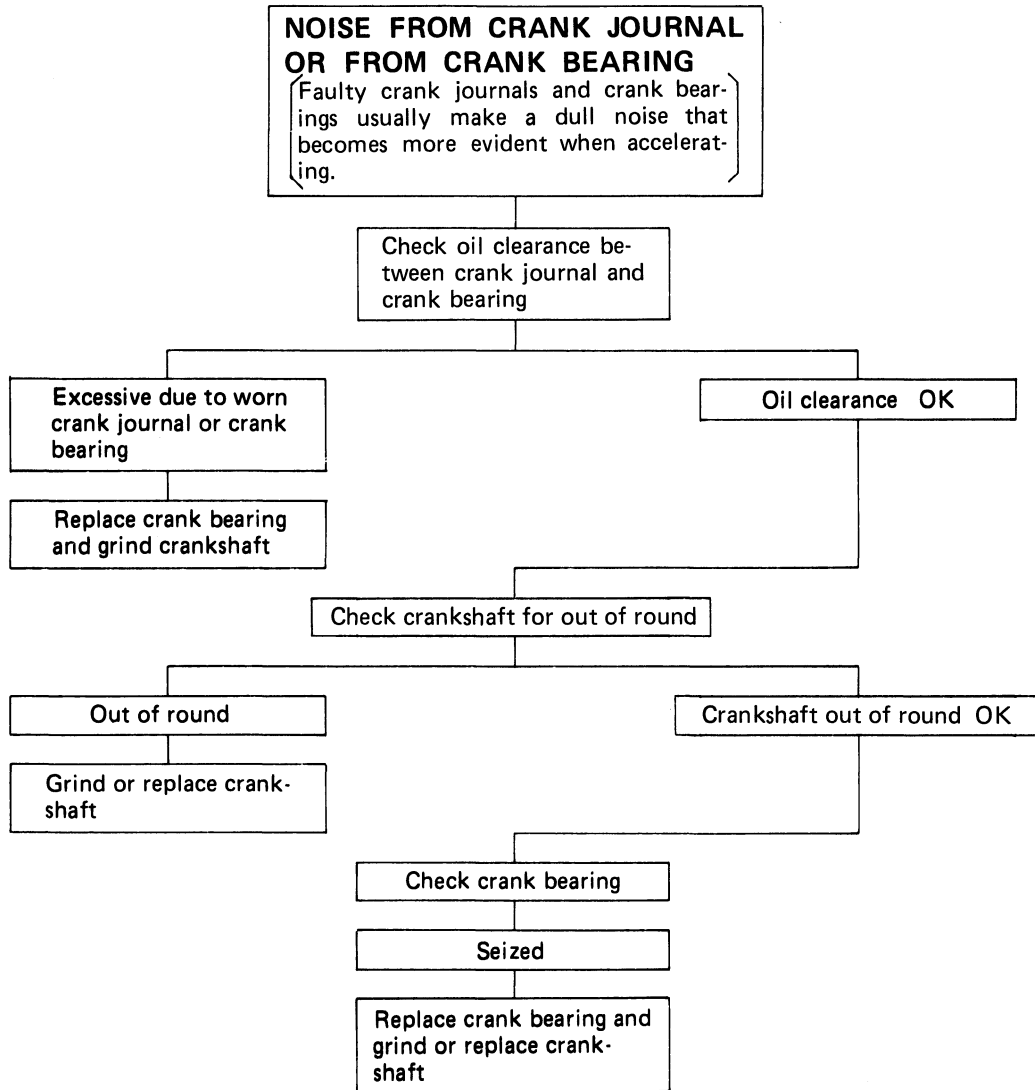

Troubleshooting procedure

Short out each spark plug in sequence with a screwdriver with an insulated handle. Locate the cylinder with the defective bearing by listening for abnormal noise that stops when the spark plug is shorted out.

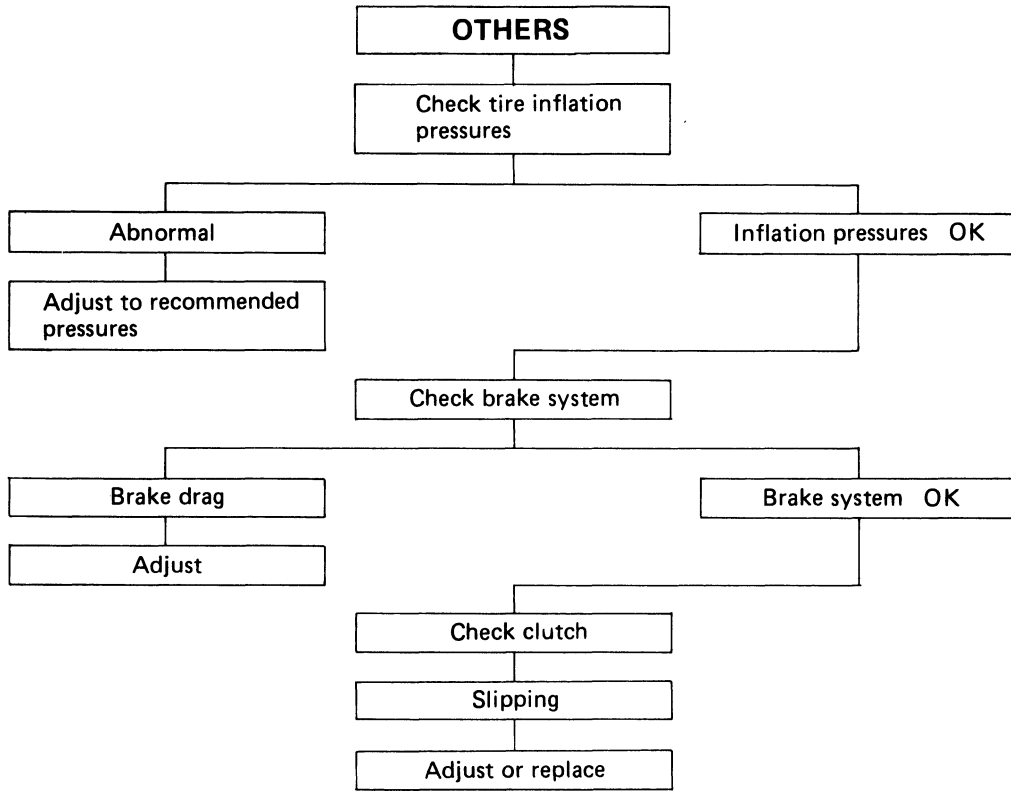

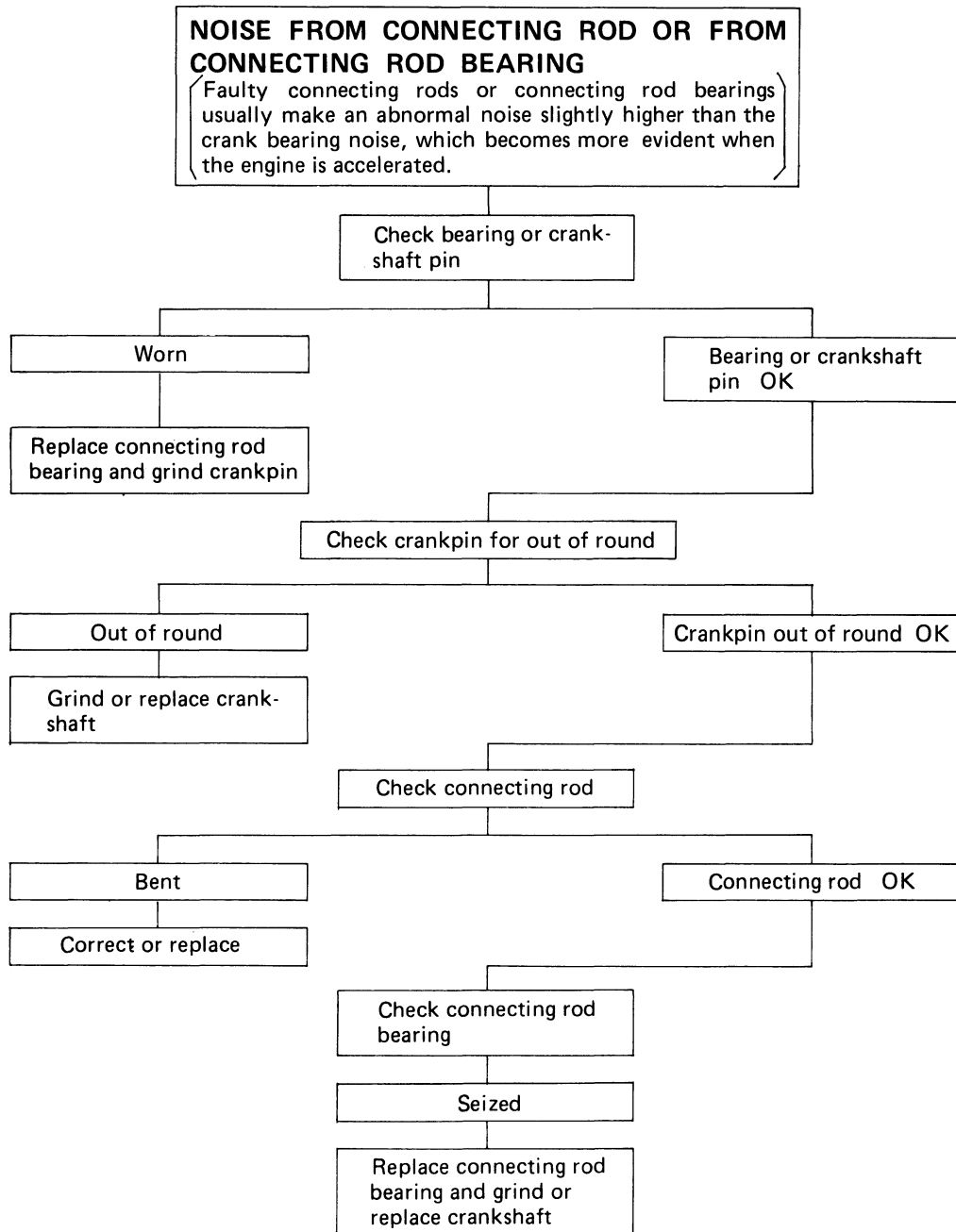

**Troubleshooting procedure**

Abnormal noise diminishes when the spark plug on the cylinder with defective parts is shorted out.

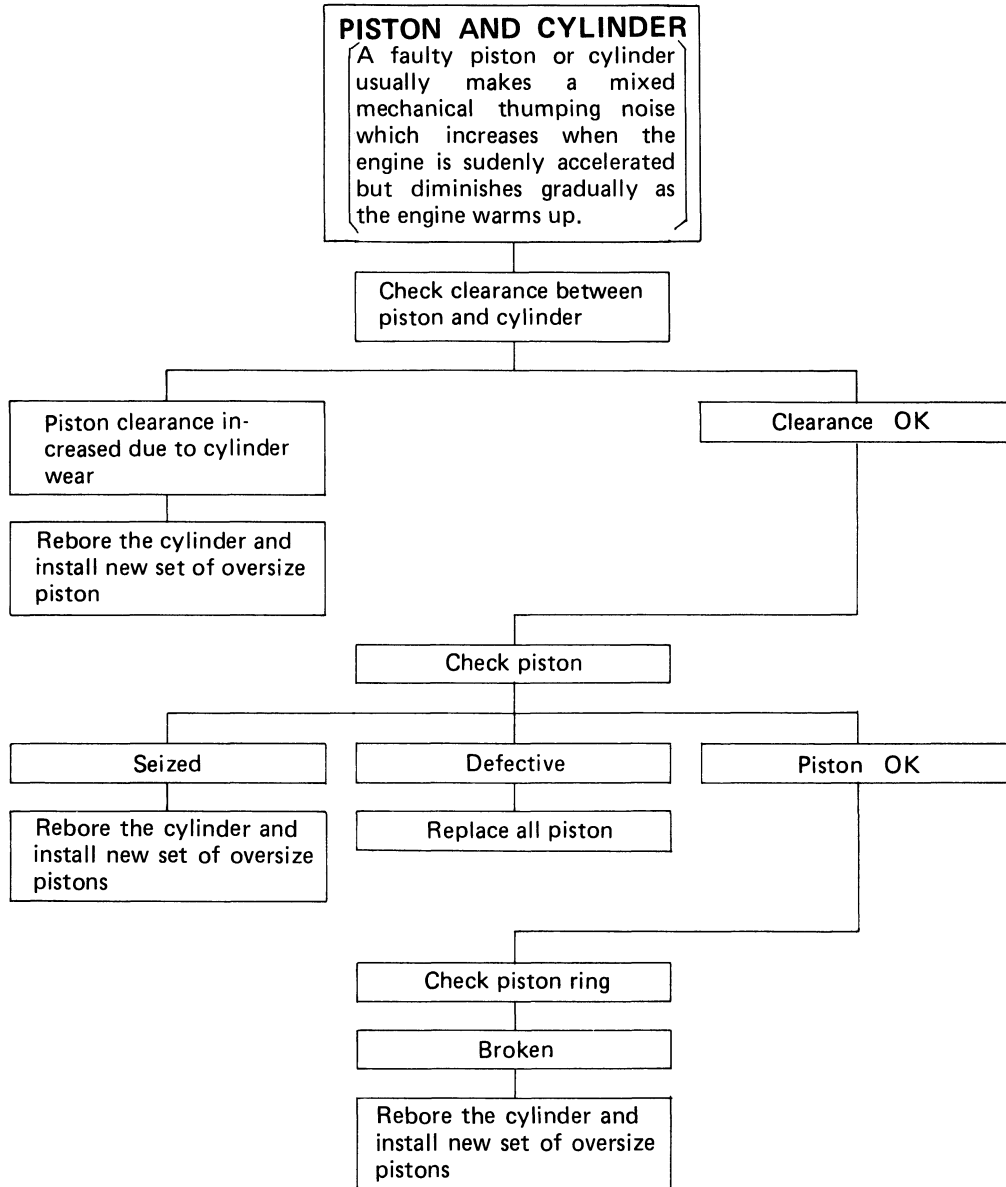

**Trouble-shooting procedure**

Short out each spark plug and listen for a change in engine noise.

# 01-94 4ZD1 GASOLINE ENGINE

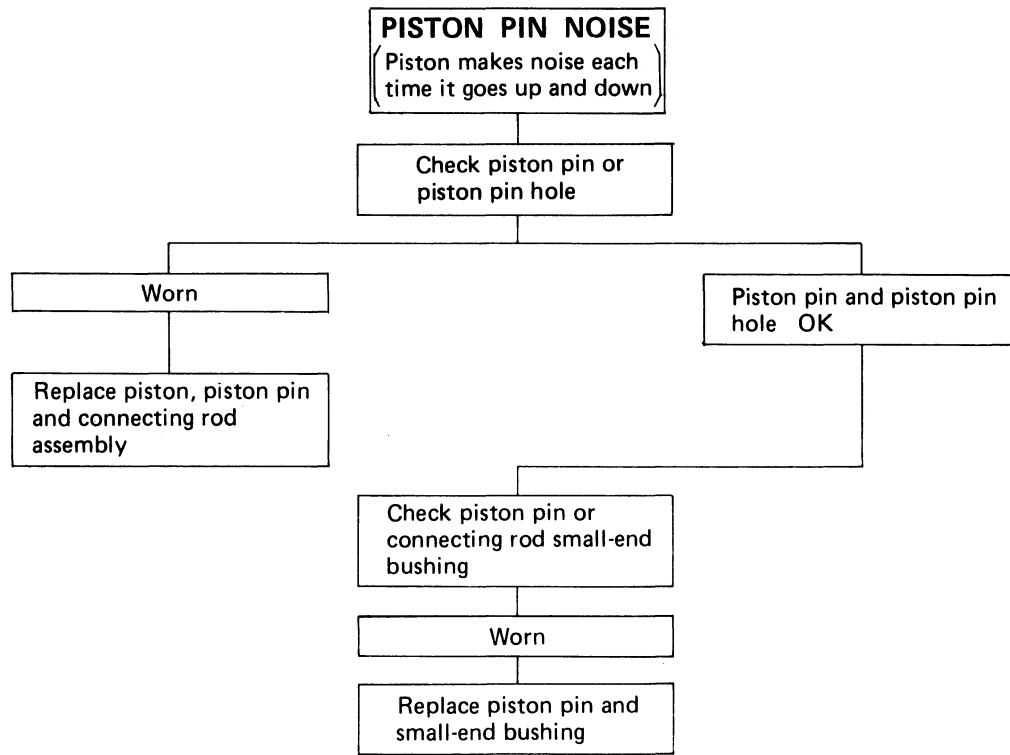

## Trouble-shooting procedure

The slapping sound diminishes when the spark plug on the cylinder with trouble is shorted out.

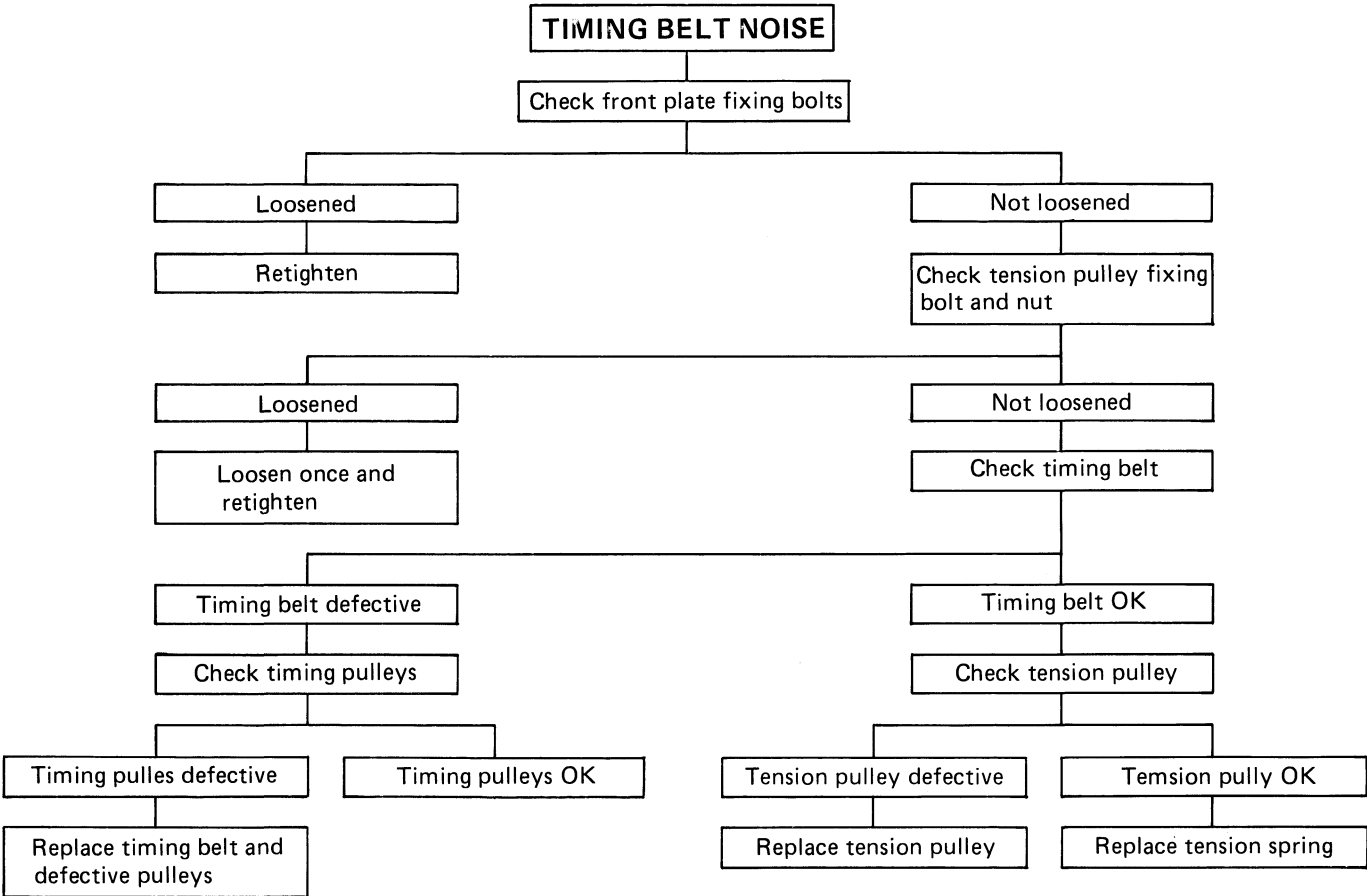

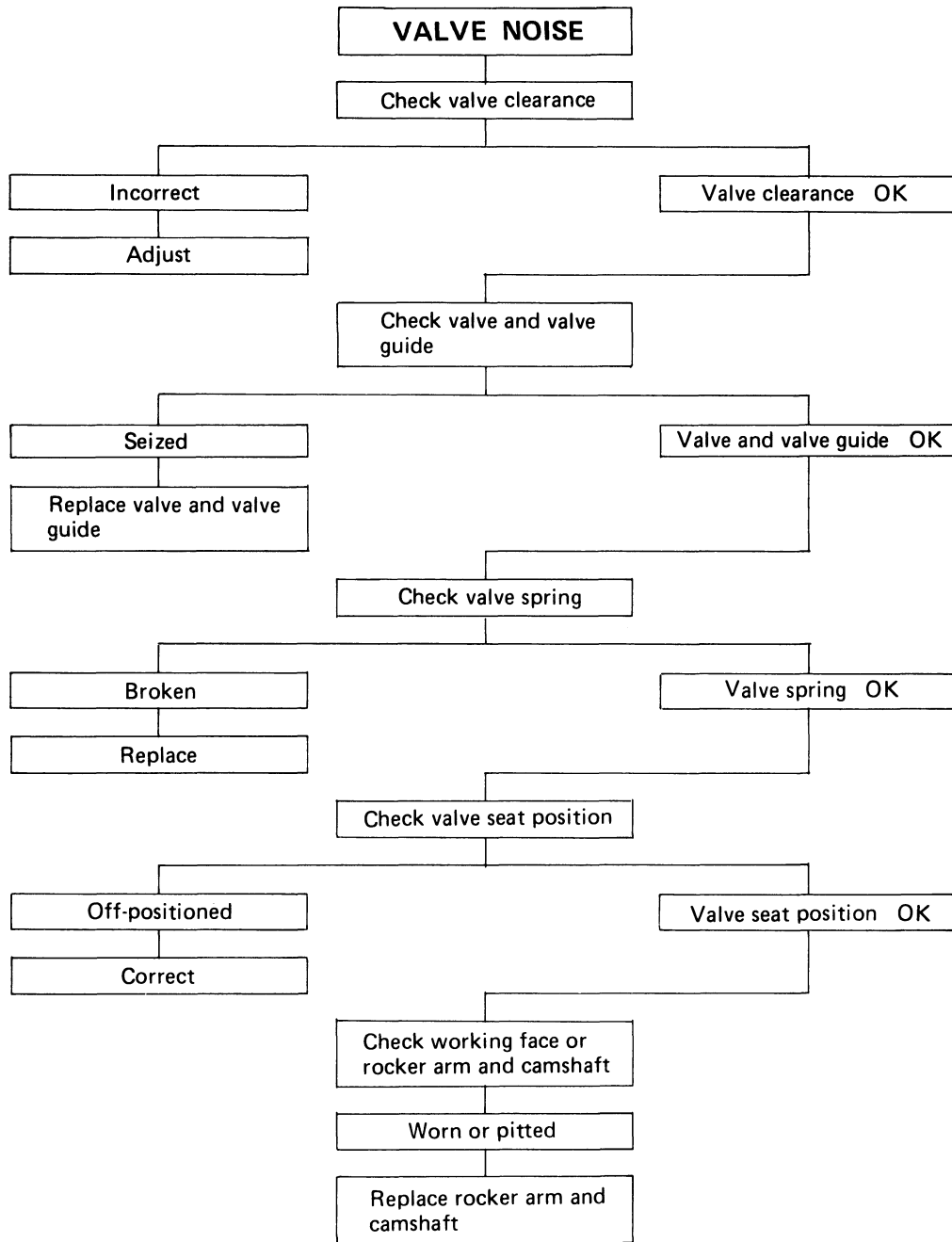



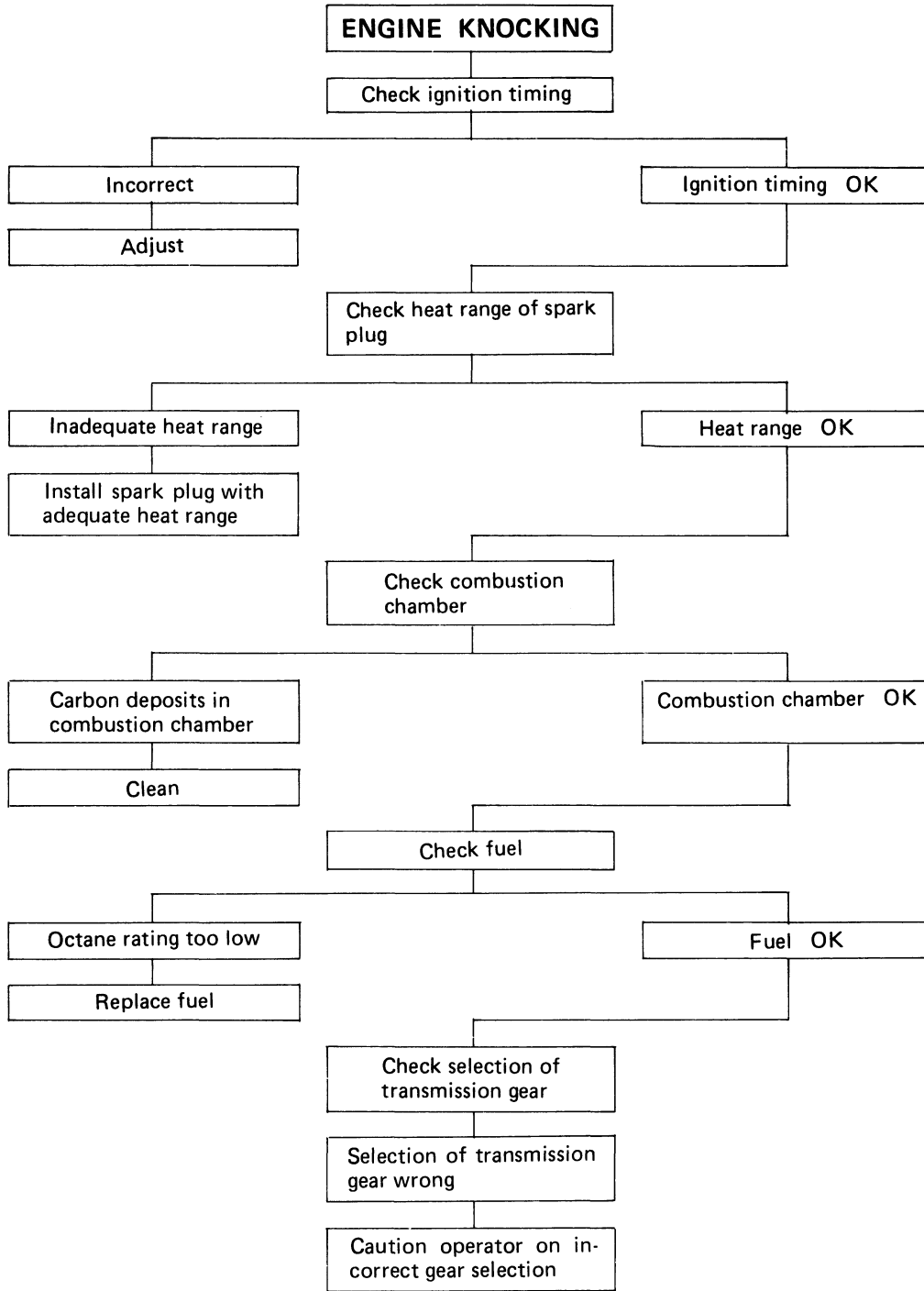

01-98 4ZD1 GASOLINE ENGINE

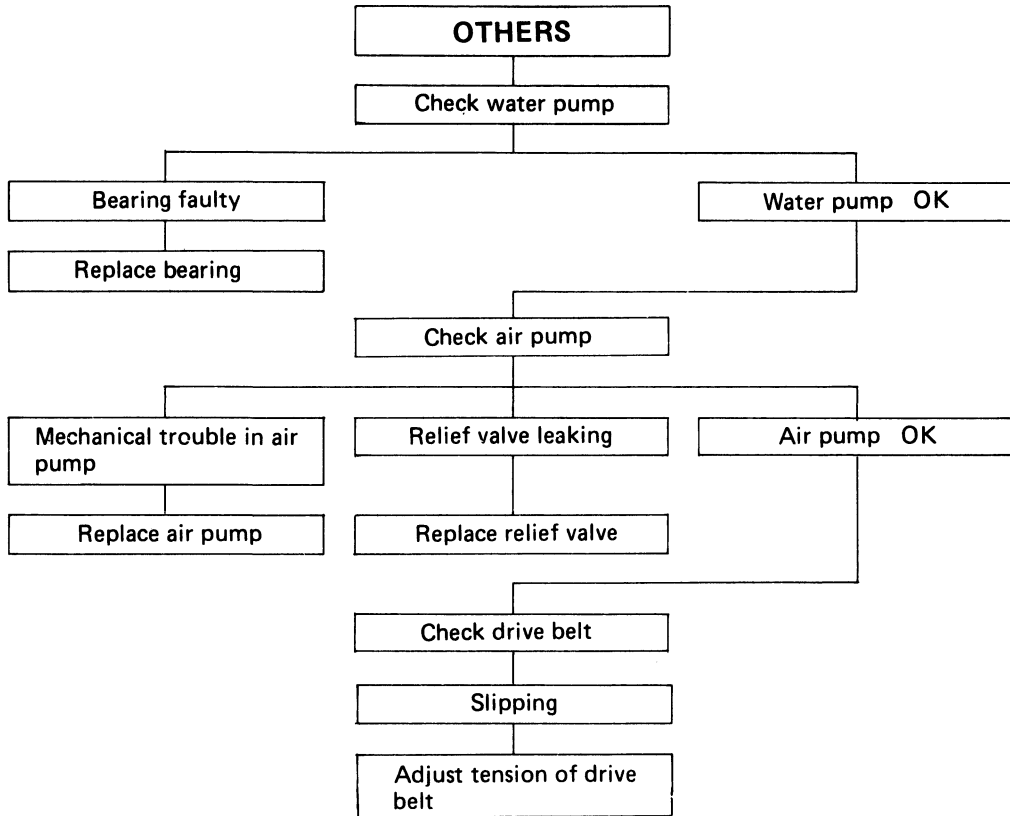

ABNORMAL COMBUSTION

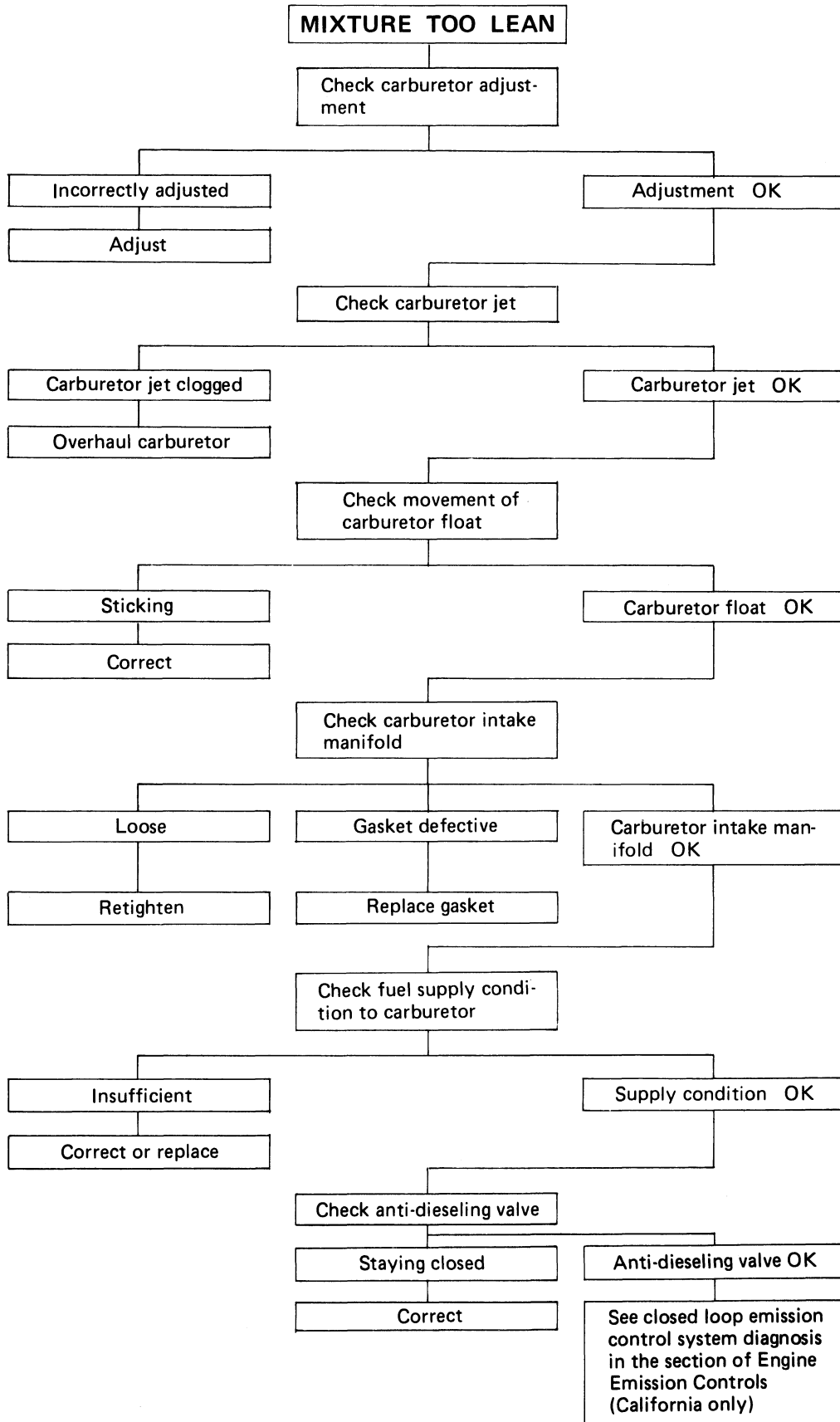

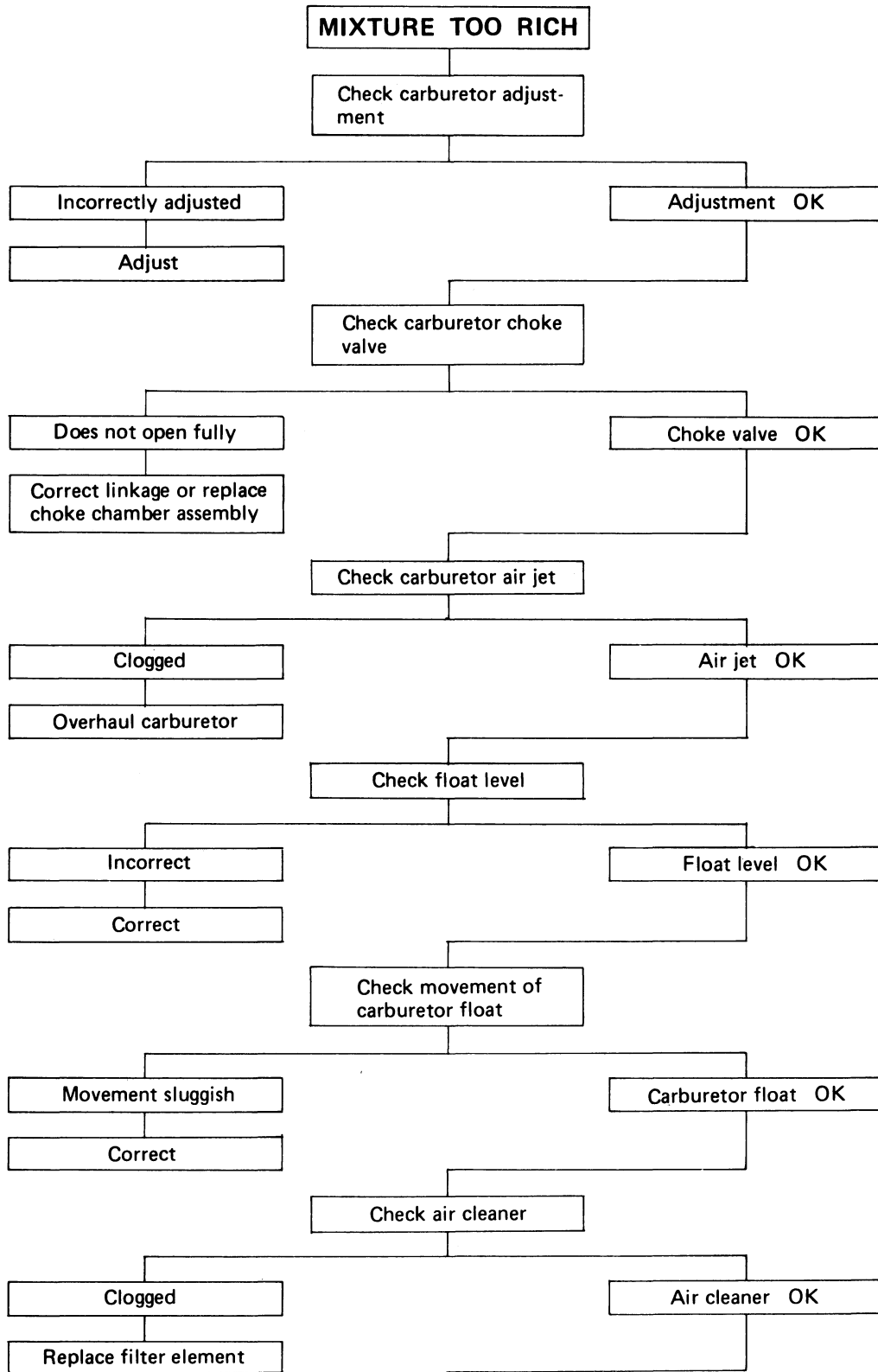

Continued on next page

(Cont.)

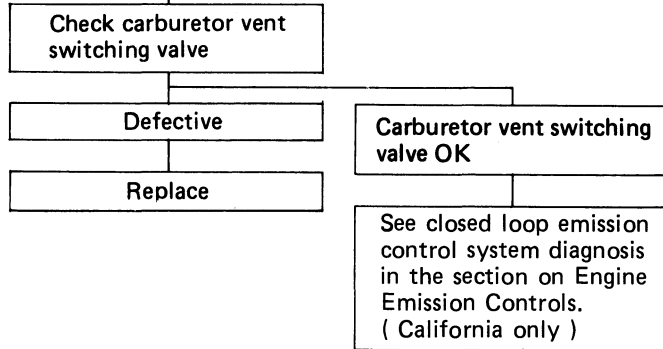

### TROUBLE IN IGNITION SYSTEM

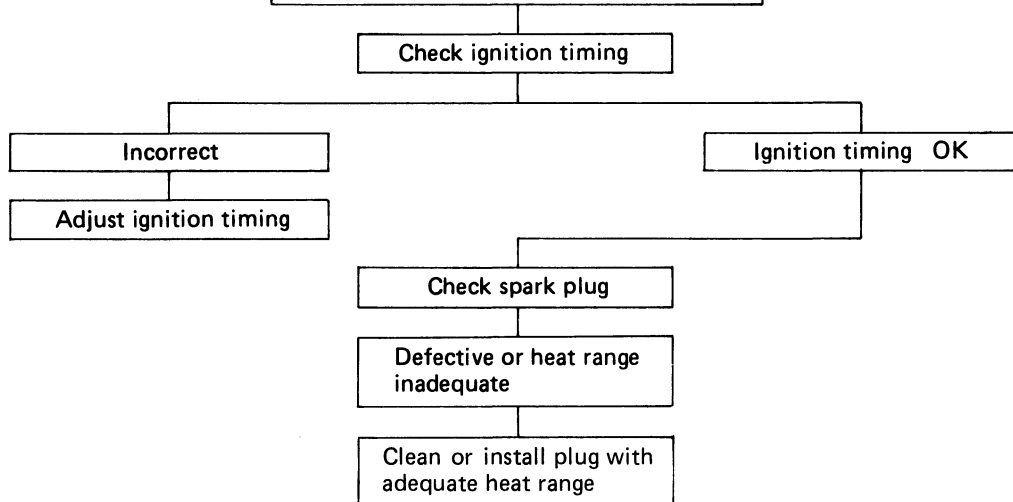

01-102 4ZD1 GASOLINE ENGINE

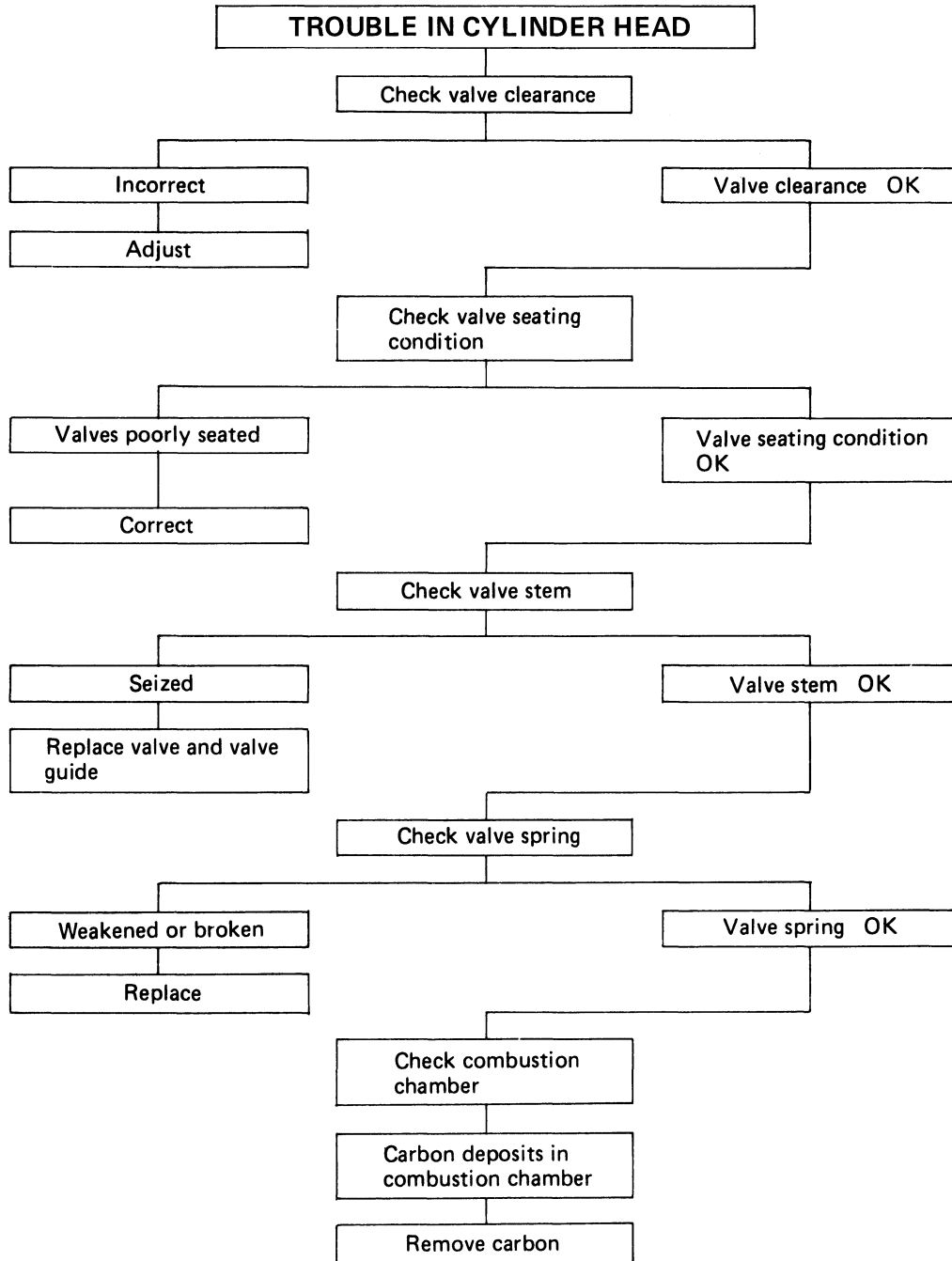

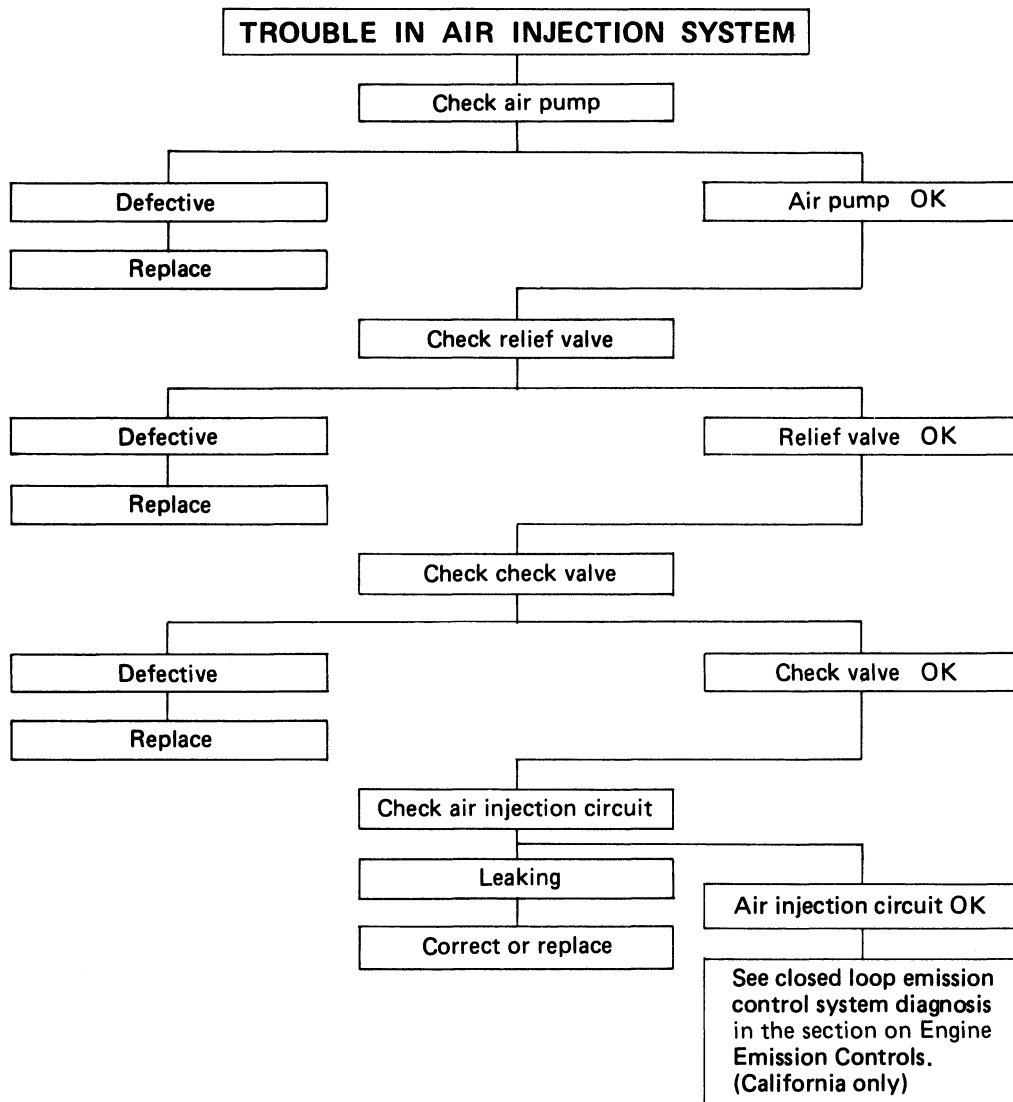

ENGINE OIL CONSUMPTION EXCESSIVE

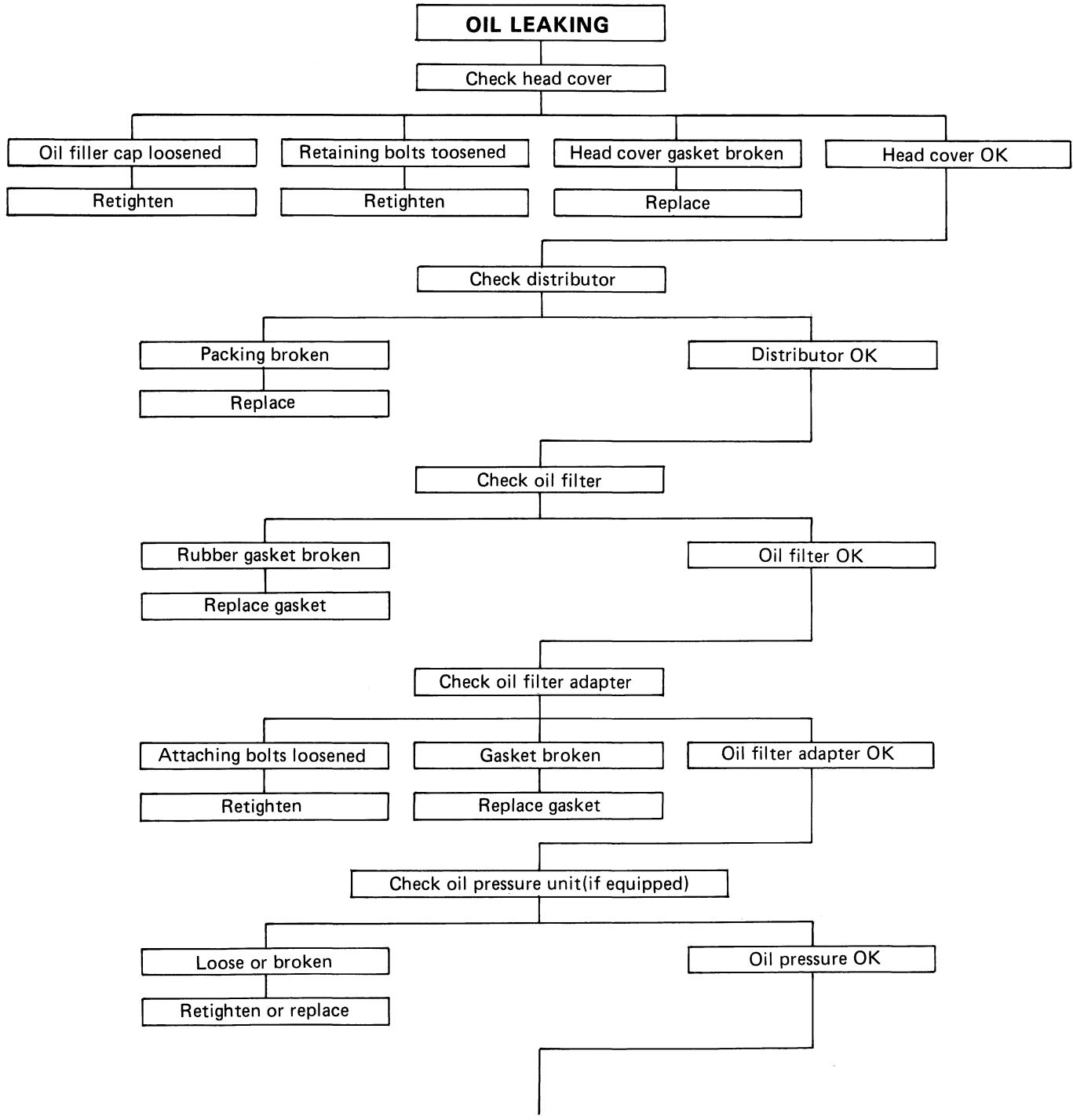



(Cont.)

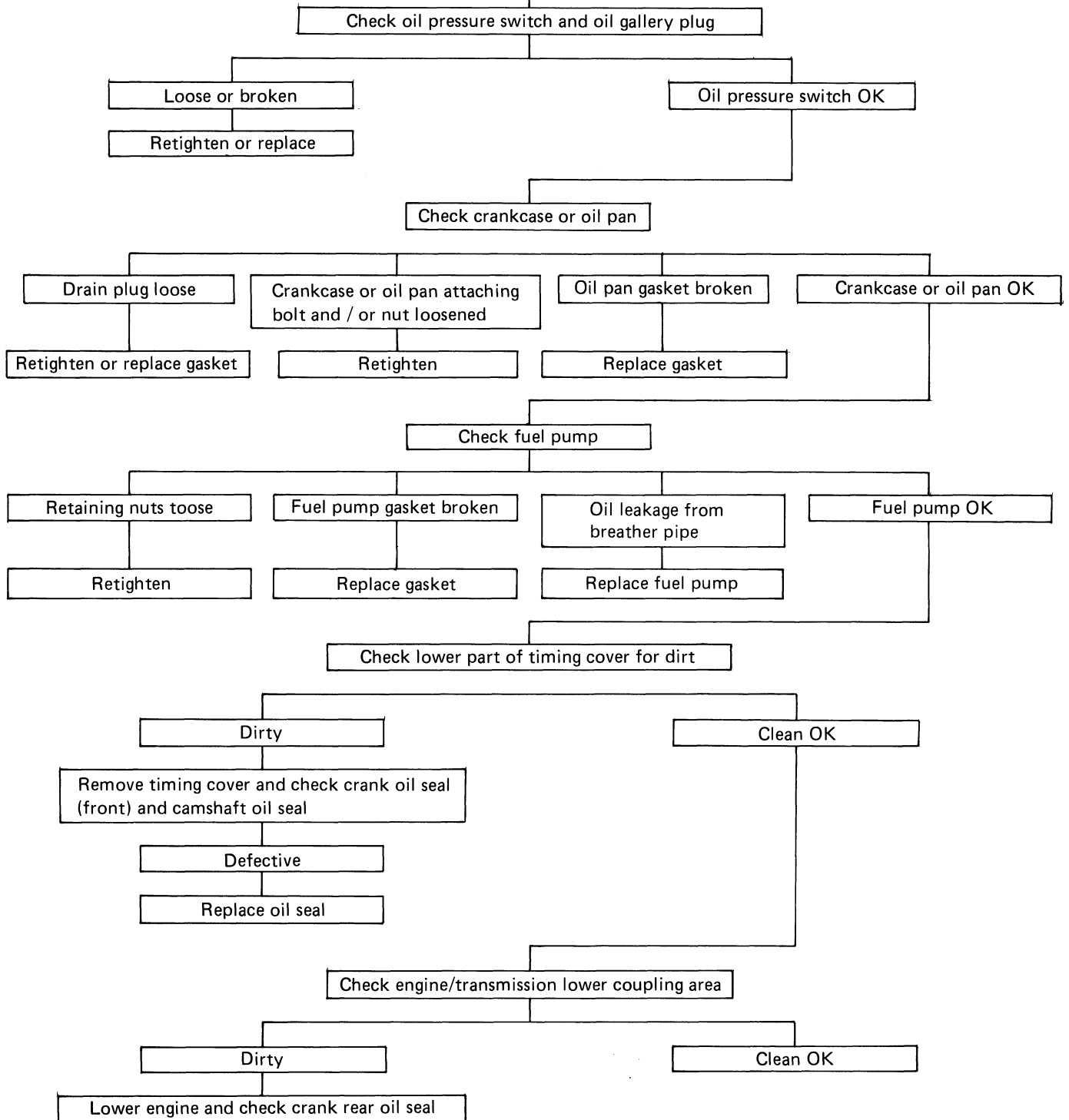

01-106 4ZD1 GASOLINE ENGINE

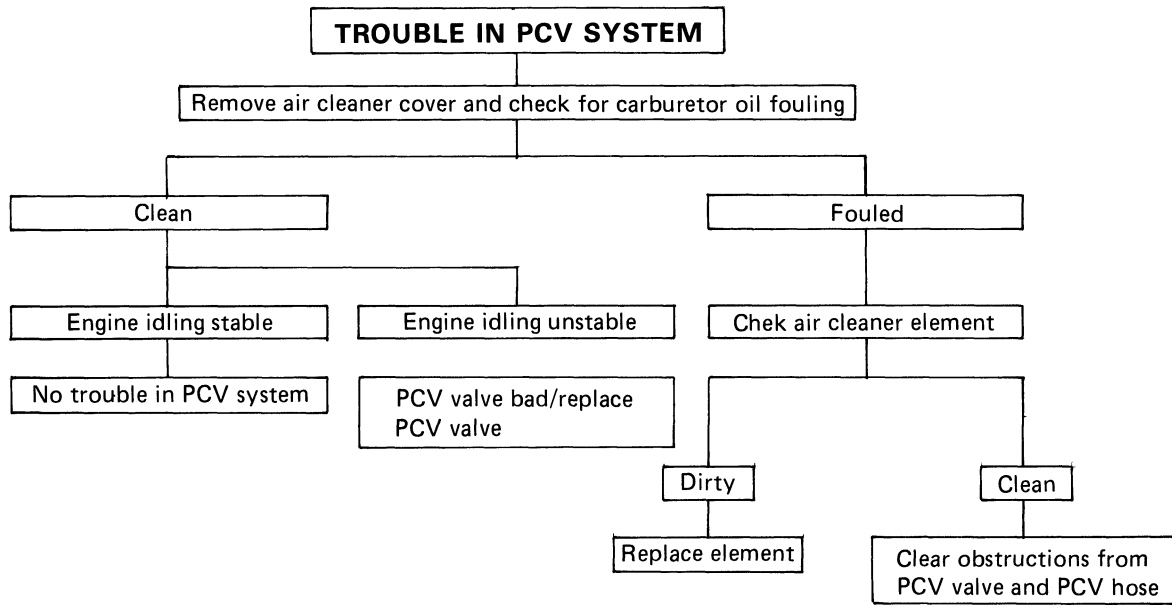

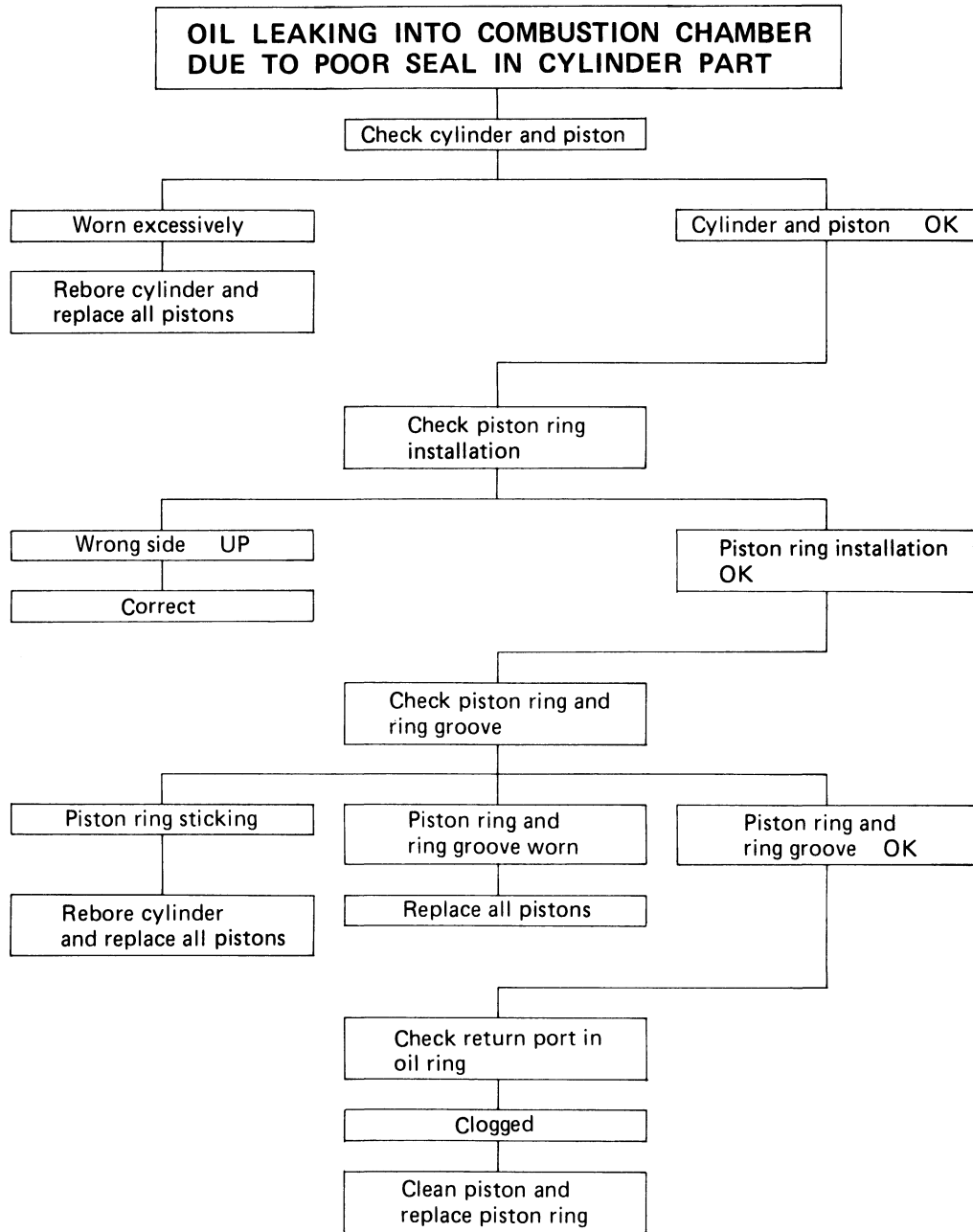





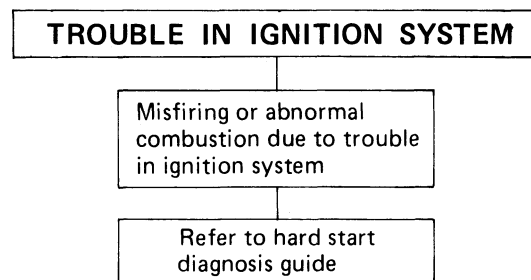
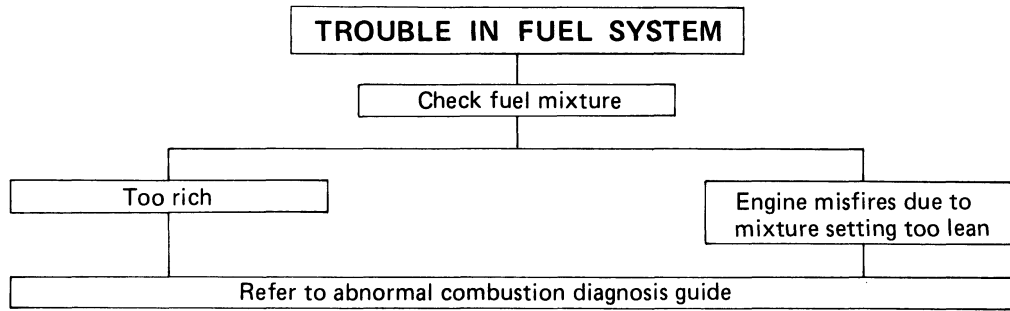

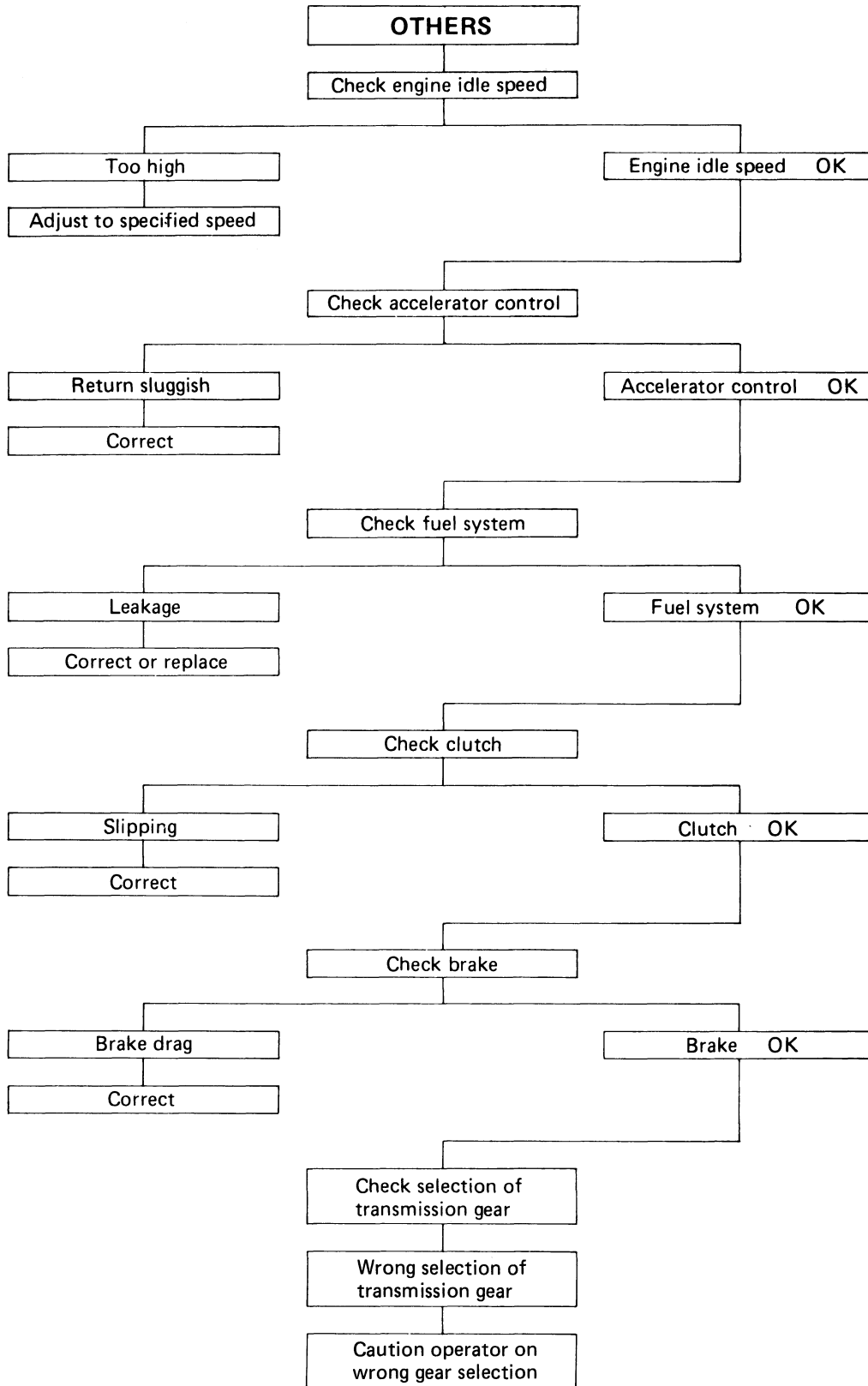



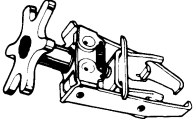

01-108 4ZD1 GASOLINE ENGINE



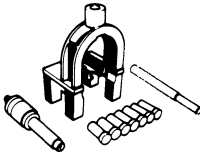

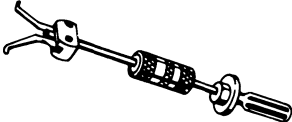

FUEL CONSUMPTION EXCESSIVE



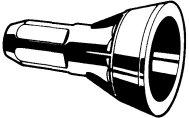

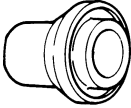
## SPECIAL TOOLS

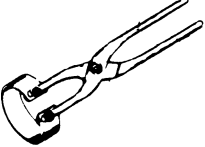
ESSENTIAL OR AVAILABLE	ILLUSTRATION	PARTS NO.	PARTS NAME
		J-26513-A	Compressor ; valve spring
		J-26512 J-26512-1 J-26512-2	Remover ; guide pin and installer Adapter ; installer
		J-24086 J-24086-8 J-24086-10 J-24086-75 J-24086-9 J-24086-5	Service set ; piston pin Remover ; Base fixture Piston support Installer ; Pin guide
		J-23097 J-33950	Remover ; pilot bearing Sleeve remover
		J-26516-A	Installer ; pilot bearing
		J-22928-A	Installer ; oil seal rear

ESSENTIAL OR AVAILABLE	ILLUSTRATION	PARTS NO.	PARTS NAME
		J-29818	Rear crankshaft seal installer
		J-26587	Installer ; oil seal front cover
		J-8037	Ring installer
		J-24460-1	Tester ; radiator cap

# MEMO