



TECHNICAL ALERT

November 22, 2000

TA00 4402

NAS US Only Cda Only

ATTENTION: *General Manager* *Sales Manager*
 Service Manager *Service Advisor* *Technician*

AT Breather Repositioning and Fluid Check



IMPORTANT NOTE: This Technical Alert supersedes and replaced TA00 4401



NOTE: The Service Action described in this Technical Alert is required due to a safety defect notification made by Land Rover North America to NHTSA. Ensure that this Technical Alert is routed immediately to all of the persons in the "ATTENTION" distribution.

Land Rover North America will be issuing a Safety Recall for vehicles in service that are within the affected VIN range. Appropriate notices will be mailed to all owners once the recall procedures are developed and verified for in-service vehicles.

VEHICLES WITHIN THE AFFECTED VIN RANGE THAT ARE IN RETAILER STOCK MUST BE MODIFIED PRIOR TO SALE.

This Service Action is to be executed on all affected new and used vehicles in Retailer inventory prior to delivery.

The **Repair 1** procedural steps only apply to undelivered vehicles which **have not been deep water waded**, which do not have a warranty start date activated and have less than 500 miles on the odometer.

The **Repair 2** procedural steps apply to new and used vehicles in retailer inventory which have in excess of 500 miles on the odometer.



NOTE: Used vehicles within the VIN range in retailer inventory, **INCLUDING DEMOS WITH AN ACTIVE WARRANTY DATE**, must pass the AT fluid test outlined below. Vehicles that fail the visibility test may *not* be retailed until the Recall bulletin for vehicles with accumulated mileage has been issued.

No action is to be taken on vehicles that have been delivered to customers. Delivered vehicles will be addressed by the Recall bulletin where additional procedures will be outlined.

AFFECTED VEHICLE RANGE:

Range Rover (LP)

XA410504 to 1A449412

Discovery Series II (LT)

XA200000 to 1A299999

XA900000 to XA907212

1A700000 to 1A706116

SITUATION:

TRANSMISSION WATER INGRESS THROUGH BREATHER

Condensation from Air Conditioning and water from a “deep wading” event can flow over the transmission and collect on the transmission breather tube on Range Rover and Discovery Series II vehicles. It can then migrate up the transmission tube. Over time these small water droplets can cause an accumulation of water in the transmission causing problems associated with water contamination – harsh gear changes, poor gear selection, gear slip or loss of drive and intermittent failure of the park lock function. Inspections and resolution for these faults will be addressed by the formal Recall.

RESOLUTION:

REPAIR 1: REPOSITION BREATHER TUBE AT PDI – NEW VEHICLES UP TO 500 MILES

At or before delivery of a vehicle to a purchaser, re-route the breather tube to the top of the transmission to eliminate the breather tube as a source of transmission contamination.

REPAIR 2: REPOSITION BREATHER TUBE AND INSPECT FLUID – NEW AND USED VEHICLES OVER 500 MILES

At or before delivery of a vehicle to a purchaser test the AT fluid as outlined in the Procedure section of the Alert. If the AT fluid is found to be **uncontaminated** by the test, re-route the breather tube to the top of the transmission to eliminate the breather tube as a source of transmission contamination.

PARTS INFORMATION:

No Parts Involved

LRN0002LABELCampaign Label Qty 1 (Order quantity 1 = 100)

WARRANTY CLAIMS:

Position breather tube

- Claim Type: M
- Campaign Code: SE25

Reimbursement Information

- Labor Allowance Option A: Perform Repair 1 0.25 hrs.
- Labor Allowance Option B: Perform Repairs 1 & 2 0.45 hrs
- Part Reimbursement: Material cost is included in Labor Allowance

Normal warranty policy and procedures apply

REPAIR PROCEDURE



CAUTION: No vehicle that has been waded, or has been delivered to a customer is to be corrected following the breather hose positioning procedure **ONLY**. Additional instructions for in-service vehicles will be provided at a later time in a Recall bulletin.

REPAIR 1: POSITION BREATHER TUBE - VEHICLES UNDER 500 MILES IN RETAILER INVENTORY

1. Raise vehicle on lift.
2. Locate end of transmission breather tube clipped to the edge of the transmission pan.(Figure 1)
3. Inspect the end of the tube for blockage or damage.
4. Unfasten clip from transmission and remove the clip from the tube. Discard the clip.
5. Guide the end of the breather tube up over the top of the transmission housing.
6. Locate the white three-hole tube-locating clip near the top of the transmission housing.
7. Spray a small amount of silicon lubricant on the breather tubing near the locating clip.

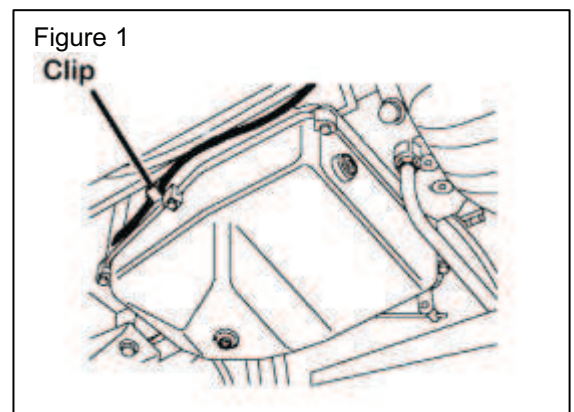



CAUTION: The orientation of the breather pipes is slightly different on Range Rover and Discovery Series II vehicles

- On Discovery the Transfer Gearbox breather and the Gearbox breather come from opposite sides of the vehicle.
 - The Discovery breather is secured to an electric harness and must be released from that restraint.
 - Movement of the white clip is limited by the divergence of the tubes.
 - Care must be exercised to avoid crimping or deforming the tubing.
8. On Range Rover vehicles slide the white tube clip toward the rear of the vehicle until it stops against the bulge at the end of the repositioned drain tube. (Figure 2)
 9. On Discovery Series II vehicles perform the following:
 - Snip the cable tie to release the breather tube from the electrical harness.
 - Slide the white tube clip toward the rear of the vehicle until resistance is met because of the divergence of the transmission and transfer box tubes. (Figure 3)
 - Verify that the end of the breather tube is parallel with the AT breather and pointed toward the LH rear of the vehicle.
 10. Wipe any residual silicon lubricant from tubes.

Figure 2
Range Rover illustration

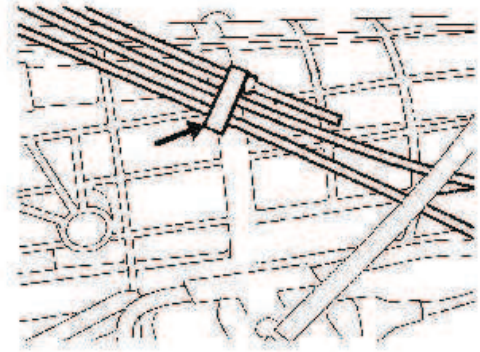
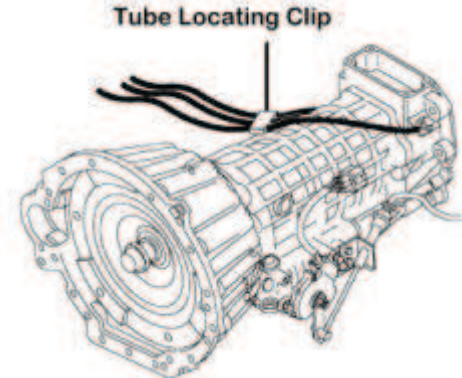

Figure 3
Discovery illustration



REPAIR 2: POSITION BREATHER TUBE AND INSPECT AT FLUID FOR CLARITY VEHICLES IN RETAILER INVENTORY OVER 500 MILES

1. Raise the vehicle on a lift.



NOTE: The testing process outlined below must be followed carefully to avoid unnecessary loss of AT fluid. Done with care and with the proper tools, approximately 100 cc (3-4 oz.) of fluid can be drained for evaluation. You must have approximately two inches of fluid in the bottom of your container when the fluid sample is taken.



CAUTION – Fluid drained from the sump pan may be ‘hot’ - Due care and attention must be observed when draining the fluid.

2. Test the fluid to determine the presence of water contamination as follows:
 - Obtain a clean clear plastic container about three inches in diameter and about 6 inches tall.
 - Using a 5mm Allen wrench break the seal on the transmission drain plug.
 - Orient the Allen wrench with the long portion vertical and carefully unscrew the plug until AT fluid seepage is observed.
 - Hold the container under the plug opening and carefully unscrew the plug until no threads are engaged but maintaining pressure against the opening.
 - Tilt the plug slightly to drain the fluid sample required to give 1.5 to 2 inches of fluid in the bottom of the container.
 - Thread the plug back into the opening.

 **NOTE: If a level of uncertainty exists as to the correct appearance of the sample, a comparison of the sample taken to new fluid from stock will be helpful.**

3. Visually inspect the fluid for the presence of water contamination against the following parameters:
 - Uncontaminated fluid will have a bright red appearance and will be “clear.” You can easily see your finger on the bottom of the clear container from the top through the 2 inches of drawn fluid.
 - Lightly contaminated fluid will have a deep burgundy red color and cloudy appearance,
 - Heavily contaminated fluid will have a ‘milky pink’ appearance.

 **WARNING: Contaminated transmissions may experience intermittent failure of the park lock function. Recall inspection and repair process will be issued for vehicles that exhibit symptoms of contaminated fluid.**

4. If the gearbox fluid exhibits a contaminated appearance THE VEHICLE MUST NOT BE SOLD and no further action can be taken until the issuance of the formal Recall documentation and procedures.
5. If the gearbox fluid is clear perform the following:
 - Re-route the gearbox breather pipe as described in procedure “Position Breather Tube - Vehicles under 500 miles in Retailer Inventory”
 - Top up the transmission fluid level to the correct level making sure to follow the procedure outlined in TIB 44/01/98/NAS.
 - Install the campaign label as outlined in the next section.

CAMPAIGN LABEL INSTALLATION

 **NOTE: Campaign labels may have multiple campaign numbers written on them if multiple campaigns are performed at the same time.**

1. When all specified repairs have been accomplished, prepare the campaign label (LRN0002LABEL) as follows:
 - a) Place the label on a hard surface.
 - b) Use a ballpoint pen to neatly write/scribe in the bare aluminum areas of the label the following information:
 - Campaign code performed (“SE25”)
 - Your Retailer code
 - The date of repair
2. Peel the label back, apply to radiator support and roll the label with the special roller.

Figure 4

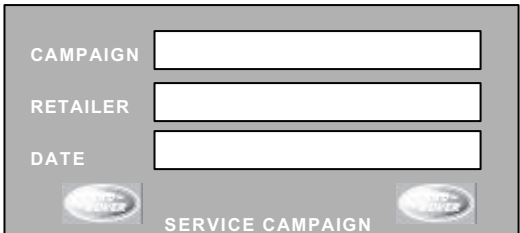

CAMPAIGN	<input type="text"/>
RETAILER	<input type="text"/>
DATE	<input type="text"/>
 SERVICE CAMPAIGN 