



# TECHNICAL INFORMATION

	
No: 76/15/99/NAS	
Ref:	
Issue: 1	
Date: 06/04/99	

## Child Seat Tether Bracket Installation

*AFFECTED VEHICLE RANGE:*

**DISCOVERY (LT) ALL**

*SITUATION:*

**AFTER-MARKET CHILD SEATS MAY REQUIRE A TETHER TO SECURE THE CHILD SEAT.**  
Some after-market child seats require tether brackets to be installed in the vehicle to properly secure the child seat. Rather than using a bracket that is supplied with the child seat, Land Rover has specified a factory approved tether bracket and trim finisher that accommodates for a tether bracket and will offer the correct tethering of child seats.

**NOTE:** There are two outboard tether locations in the vehicle

*RESOLUTION:*

**FIT FACTORY APPROVED CHILD SEAT TETHER BRACKET.**  
Upon customer request, fit seat tether bracket to the vehicle following the procedure below for 5 or 7-seater vehicles.

*INSTALLATION TIMES*

**0.20 hrs .....Center Position Installation**  
**0.20 hrs .....Outboard Position Installation, each**

*PARTS INFORMATION:*

**LRN0449.....Child Seat Tether Bracket**  
**EDV100440LUM.....Rear Header Finisher (7-seater), Center Position Only – Availability Pending**  
**EDV100460LUM.....Rear Header Finisher (5-seater), Center Position Only**

*WARRANTY CLAIMS:*

*Normal warranty policy and procedures apply*

<b>TIB</b> 76/15/99/NAS	<b>CIRCULATE:</b> <b>TO</b>	<b>Service Mgr</b> <b>X</b>	<b>Warranty</b> <b>X</b>	<b>Workshop</b> <b>X</b>	<b>Body Shop</b> <b>X</b>	<b>Parts</b> <b>X</b>
----------------------------	--------------------------------	--------------------------------	-----------------------------	-----------------------------	------------------------------	--------------------------



## REPAIR PROCEDURE:

### CHILD SEAT TETHER BRACKET INSTALLATION (CENTER POSITION).



**CAUTION:** . To avoid damage to the rear header finisher, pry the finisher off at the clipping points.

1. If vehicle is 7-passenger configuration, perform the following:
  - Place the head restraints in the stored position.
  - Carefully remove the trim finisher from the clips.
  - Once unclipped from the body, hold the finisher out of the way and carefully fold the head restraints downward.
  - Remove the finisher.
2. If vehicle is 5-passenger configuration, carefully remove rear header finisher.
3. Carefully remove the two trim studs securing the edge of the headliner to the body.
4. Locate mounting hole in body (on the centerline of the vehicle).



**NOTE:** Tracing the spacer while located on the center point of the hole aids in cutting the correct size and location. The hole must be large enough to allow the spacer for the bracket to pass through

5. Carefully cut a 15mm (5/8 inch) diameter hole in the headliner around the attachment location.
6. Remove the tape patch over the body attachment location.
7. Apply Loctite 242 to threads of bolt.
8. Fit tether bracket as shown in Figure 1.
9. Torque bolt to **35Nm (25lb.ft)**.



**NOTE:** Ensure that all the spring clips are removed from the old finisher, and body, and securely pushed onto the new finisher.

10. Remove the spring clips from the older header finisher and fit to new header finisher.
11. If 7-passenger configuration, deploy head restraints.
12. Line up clips to body holes and push clips/finisher assembly home to fit new header finisher.
13. If 7-passenger configuration, store head restraints after the finisher is fitted.

Figure 1

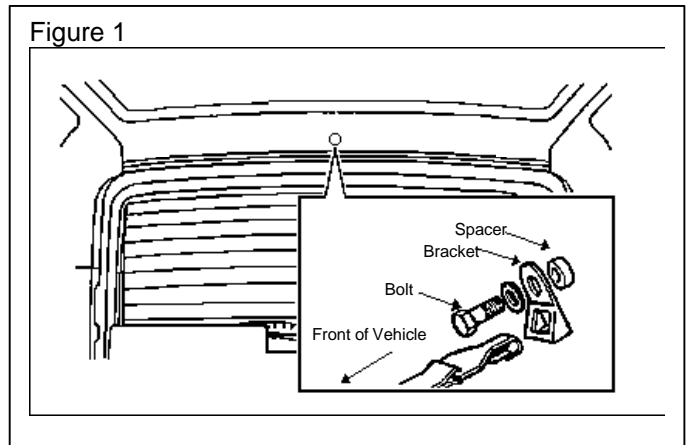



## CHILD SEAT TETHER BRACKET INSTALLATION (OUTBOARD POSITIONS).

1. Carefully remove seat back trim panel of the requested side (60% or 40%).
2. Locate anchor point for tether bracket. See Figure 2.



**NOTE: The anchor mounting hole must be large enough to allow the spacer to pass through and sit flush on the seat frame. Cut the hole from the trimmed side and insure that the hole has a clean edge to it.**

3. Refer to dimensional locations supplied in Figures 3 and 4 and drill a 15mm (5/8 inch) hole.
4. Align the trim panel fir-tree studs with the seat back cupsacks prior to trim panel installation.
5. Carefully install the trim panel,
6. When the trim panel is installed, assemble the bracket and hardware in the same order as illustrated for the header position (Refer to Figure 1).

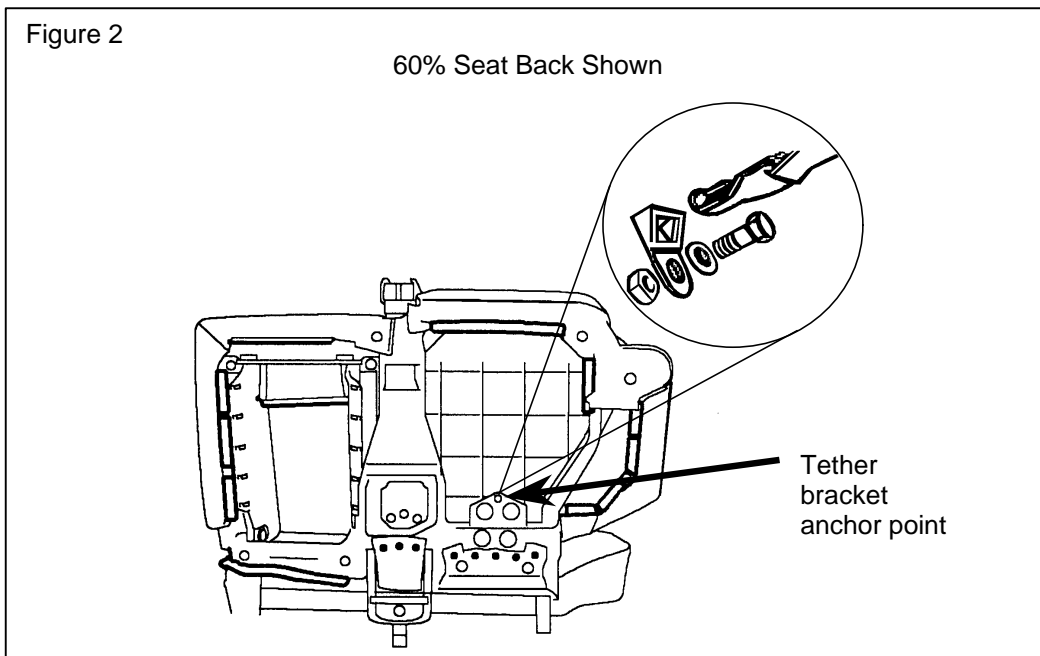

7. Apply Loctite 242 to threads of bolt threads and install.
8. Torque bolt to **35Nm (25lb.ft)**.
9. Inform customer of anchor point locations.

