



# TECHNICAL INFORMATION

	
No:	76/03/99/NAS
Ref:	
Issue:	3
Date:	07/30/99

## Front Power Seat Mechanism Binding

*AFFECTED VEHICLE RANGE:*

**DISCOVERY Series II (LT) ALL**

*SITUATION:*

**FAILURE OF POWER SEAT TO MOVE CORRECTLY**

A customer may complain of binding seats or seats which move erratically. These symptoms may be the result of insufficient lubrication on adjustment lead screws or tension introduced into the seat frame by an incorrect mounting process. Seat frame alignment to the body may require a spacer.

**NOTE: A similar symptom can occur on non-powered seats. The customer may experience resistance when moving the seat fore-and-aft. The correct torque and spacer installation used for power seats may be a remedy for similar binding conditions on non-powered seats.**

*RESOLUTION:*

**SEAT TRAVEL DURATION AND SEAT FRAME MOUNTING TORQUES**

To resolve the symptoms of a binding seat mechanism, inspect the seat for correct fore/aft travel characteristics and duration. Apply lubricant to the under-seat lead screw mechanism and correctly torque the seat platform as outlined in the procedure below using spacers as required.

*PARTS INFORMATION:*

<b>WA110061L</b> .....2 mm (0.080 in.) Spacer washer	<b>Qty 2</b>
<b>LRNR600D</b> .....EVO Lube R-600-D	<b>2 cc (0.07 oz.) per leadscrew.</b>

*WARRANTY CLAIMS:*

**78.10.89/26** .....Time 0.60 hrs.  
**Slacken and torque seat-mounting bolts installing spacer if required.**  
**Lubricate leadscrew mechanism. Time for each seat.**

**FAULT CODE: F**

*Normal warranty policy and procedures apply*

*REPAIR PROCEDURE:*

**INSPECT FOR INCORRECT TRAVEL CHARACTERISTICS**

1. Start the engine and allow idle to stabilize.
2. Using a timer, cycle the **unoccupied** seat from the fully forward position to the fully aft position. The observed elapsed time should be 20 seconds or less.
3. During travel observation, note any slowing of seat movement or symptoms of binding.
4. If binding or extended travel time (above 20 seconds) is confirmed, perform the following repairs.

<b>TIB</b> 76/03/99/NAS	<b>CIRCULATE:</b> <b>TO</b>	<b>Service Mgr</b> <b>X</b>	<b>Warranty</b> <b>X</b>	<b>Workshop</b> <b>X</b>	<b>Body Shop</b> <b>X</b>	<b>Parts</b> <b>X</b>
----------------------------	--------------------------------	--------------------------------	-----------------------------	-----------------------------	------------------------------	--------------------------



Figure 1

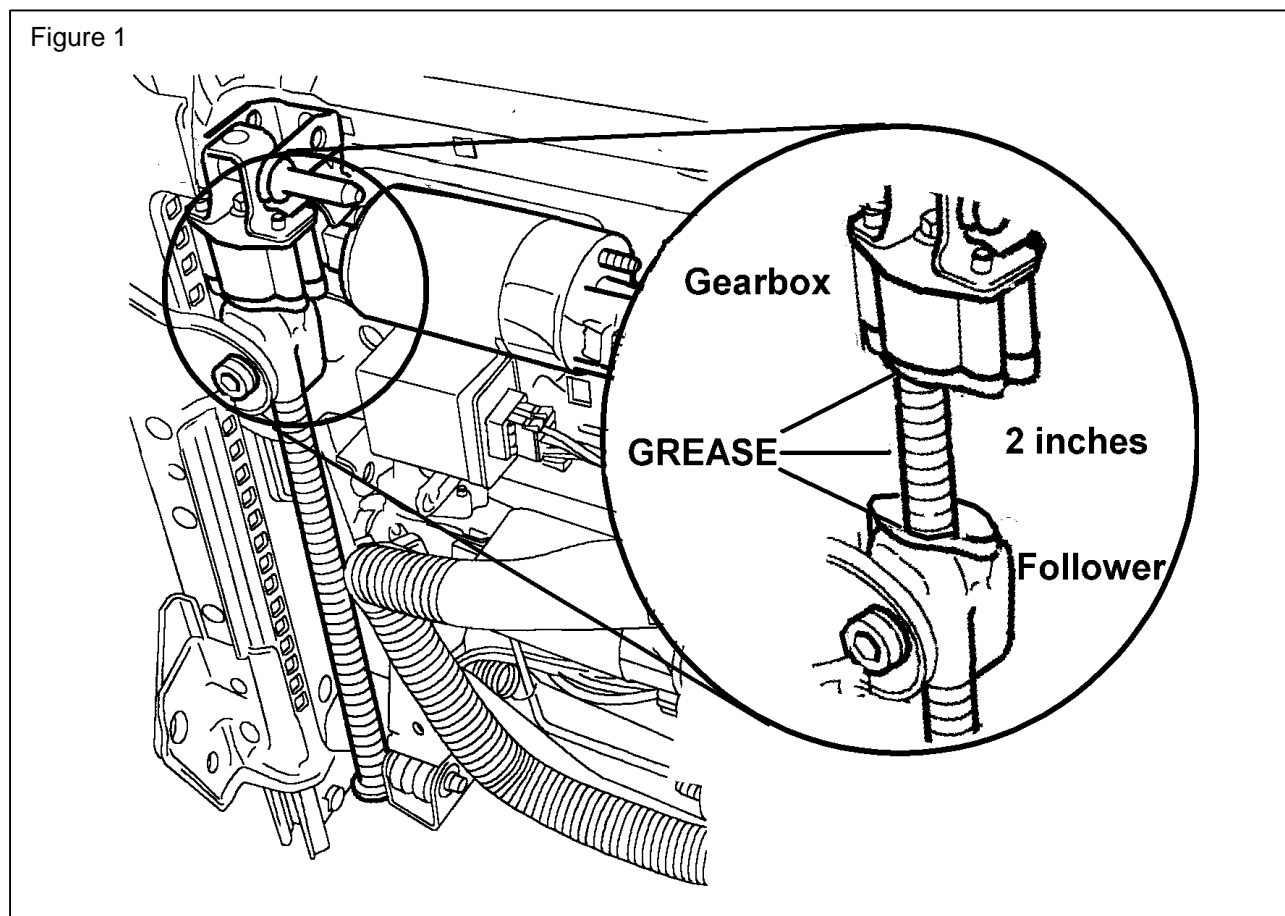

## LEADSCREW LUBRICATION



**CAUTION:** The use of washers or other foreign materials as a “buffer” on the lead screw may damage the seat mechanism. Use only the EVO-Lube grease as described below to affect the repair.

1. Perform the following lubrication procedure:
  - Raise the seat cushion to its highest adjustment position.
  - Move the seat to a location two inches forward of its rear-most position.
  - Apply EVO-Lube grease liberally to the face of the gearbox where it interfaces with the leadscrew.
  - Apply EVO-Lube grease liberally to the face of the leadscrew follower where it interfaces with the leadscrew.
  - Apply EVO-Lube grease liberally to the leadscrew.



## SEAT MOUNTING FASTENER TORQUE

1. Loosen all four mounting bolts.
1. Tighten the bolts to **45 Nm (33 lbf.ft.)** in the sequence specified by the numbers in Figure 2.
2. Perform unoccupied seat travel time observation to determine if properly torqued frame has resolved the problem.

 **NOTE: No more than 2 spacers for a total of 4mm (0.160 in.) may be used in the following step.**

3. If excessive travel time or binding is observed after correct torque sequence, perform the following repair:
  - Remove the inboard rear fastener (Figure 2, Position 2).
  - Measure the space between the space frame and the chassis floor.
  - Install a maximum of two 2mm (0.080 in.) spacer washers on the Position 2 fastener between the seat frame and the chassis floor to fill the measured gap.
4. Tighten the Position 2 bolt to **45 Nm (33 lbf.ft.)**.
5. Verify unhindered seat travel:
  - With the engine running, cycle the unoccupied seat from the fully forward position to the fully aft position.
  - The elapsed time should be 20 seconds or less.
  - Verify smooth seat movement during travel observation.
  - Verify no binding at the end of rearward seat travel.

Figure 2

