

TECHNICAL INFORMATION



No: 86/08/01/NAS
Ref:
Issue: 1
Date: 07/27/01

Knocking Noise When Starting

AFFECTED VEHICLE RANGE:

Discovery Series II (LT)	XA900012 to XA907212 XA200412 to 1A299999 1A700000 to 1A729921
Range Rover 4.0/4.6 (LP)	XA410483 to 1A459035

SITUATION:

KNOCKING SOUND WHILE STARTER OPERATING, OR STARTER FAILURE

The customer may complain that a knocking noise is heard when the starter motor is activated. The noise will go away when the engine starts and the starter disengages. The starter pinion may be coming in contact with original style drive plate balance weights.

RESOLUTION:

INSTALL NEW DRIVE PLATE BALANCE WEIGHTS

New configuration drive plate balance weights have been developed to eliminate the potential contact with the starter during engagement. The new weights should be installed when a customer complaint is confirmed and whenever a new starter is installed on vehicles within the affected VIN range.

PARTS INFORMATION:



NOTE: The new 9.5 gram weight replaces the original 9.5 gram and 9.7 gram weights, (Refer to items 4 and 5 on Attachment 1).

LBB000550 Kit, Balance Weights (See Attachment 1)

- 3.3 gram Qty 2
- 4.3 gram Qty 2
- 6.4 gram Qty 2
- 9.5 gram Qty 1

WARRANTY CLAIMS:

12.53.89/41..... Time 0.55 hrs.
Install replacement drive plate balance weights

FAULT CODE: K

Use applicable starter motor replacement operation number if required.

Normal warranty policy and procedures apply.

Material allowance is included in labor operation.

TIB	CIRCULATE:	Service Mgr	Warranty	Workshop	Body Shop	Parts
86/08/01/NAS	TO	X	X	X	X	X

REPAIR PROCEDURE

INSTALL NEW SPECIFICATION DRIVE PLATE BALANCE WEIGHTS

 **NOTE:** The new weights should be fitted whenever a starter motor is replaced. Always perform the procedures in TIB 86/04/00/NAS before replacing a starter motor for a “no-crank/no-start” symptom. If the starter requires replacement, inspect pinion and over-run clutch for evidence of contact or “machining” damage to components. If damage is evident, balance weight replacement is required to remove the source of the damage.

1. Confirm customer complaint of noise when cranking.
2. Disconnect the battery earth lead.
3. Raise the vehicle.
4. Identify the two rubber access plugs fitted to the rear flange of the engine oil sump.

 **NOTE:** Determining the best rubber plug to remove is a vehicle-dependant technician choice.

5. Select and remove the most convenient plug for access.







 **CAUTION:** Any weights dropped into the power unit must be retrieved via the access plate on the gearbox.

6. Replace the drive plate balance weights with the low profile balance weights from kit (LBB000550) as follows:
 - Rotate the drive plate until a weight becomes visible through the plug opening.
 - Carefully remove that weight using an Allen wrench.
 - Select a new balance weight from the kit, of equivalent mass to the original removed weight.
 - Fit the new weight to the drive plate in the same location as the removed weight.
 - Tighten weight securing Allen screw to 10 Nm (88.5 lbf.in.).

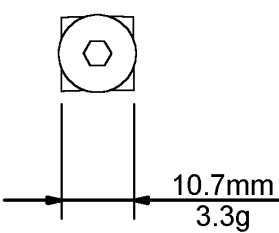
 **CAUTION:** Refer to *Attachment 1* for dimensional and visual identification of original weights and the equivalent mass new weights.

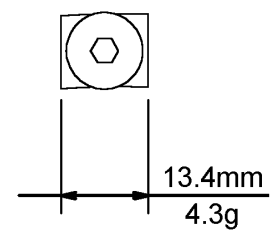
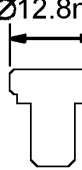
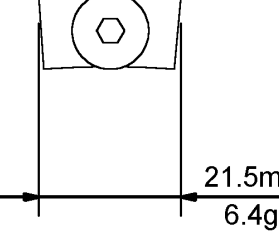
- The replacement weight must always be fitted to the same hole from which the original weight was removed.
 - Always replace the weights on a **ONE FOR ONE BASIS** to ensure that they are of the correct mass and fitted in their correct positions.
 - The new balance weight is designed so that it can only be fitted in one orientation.
7. Repeat the replacement process in step 6 until all weights have been replaced.
 8. When all weights are in position and tightened, rotate the drive plate one complete revolution to confirm that all weights have been replaced.
 9. Refit the rubber access plug to the rear flange.
 10. Lower the vehicle and reconnect the battery ground cable.
 11. Verify proper starter operation.

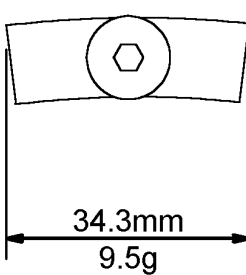
Attachment 1

	Original Weight		Replacement Weight
1	 <p>Ø9mm 3.3g Steel</p>		 <p>10.7mm 3.3g</p>
2	 <p>Ø10.1mm 4.3g Steel</p>		 <p>13.4mm 4.3g</p>
3	 <p>Ø12.8mm 6.4g Steel</p>		 <p>21.5mm 6.4g</p>
4	 <p>Ø12.5mm 9.5g Brass</p>		 <p>34.3mm 9.5g</p>
5	 <p>Ø16.5mm 9.7g Brass</p>		