

SUB-SUB-SECTION H3.4

CHAPTER 5

CLUTCH PEDAL - REMOVAL AND REPLACEMENT

REMOVAL

1. To remove the clutch pedal:

(1) Remove the bonnet (see Sub-section M3, Chapter 1).

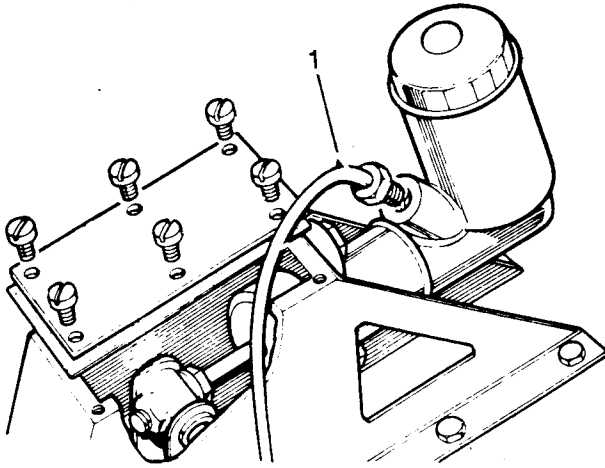

Fig H3.9

(2) Refer to Fig H3.9. Disconnect the fluid pipe (1) from the clutch master cylinder.

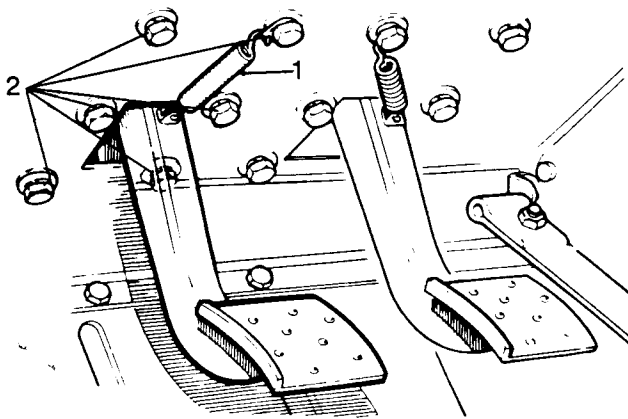

Fig H3.10

(3) Refer to Fig H3.10. Disconnect the return spring (1) from the pedal.

(4) From inside the cab remove the six fixing bolts (2) securing the clutch pedal bracket.

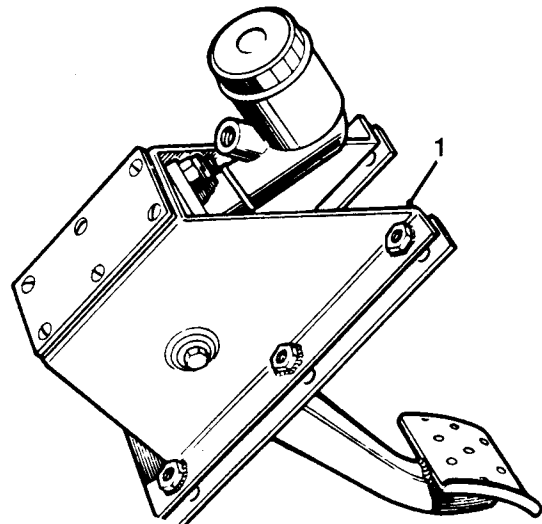

Fig 3.11

(5) Refer to Fig H3.11. Withdraw the bracket (1) complete with pedal and master cylinder.

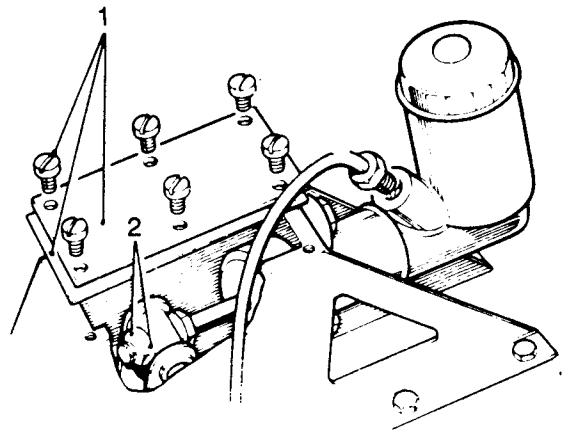

Fig H3.12

(6) Refer to Fig H3.12. Remove the top cover and gasket (1) from the clutch pedal bracket.

(7) Remove the nut (2) from the end of the master cylinder push rod and push rod into the master cylinder to clear the pedal trunnion.

SUB-SUB-SECTION H3.4

CHAPTER 5

CLUTCH PEDAL - REMOVAL AND REPLACEMENT

REMOVAL

1. To remove the clutch pedal:

(1) Remove the bonnet (see Sub-section M3, Chapter 1).

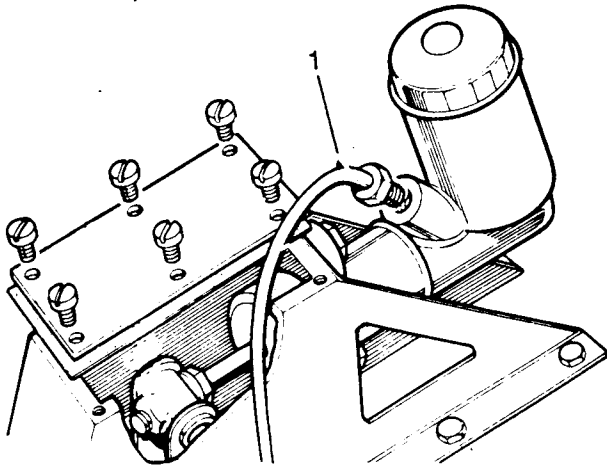

Fig H3.9

(2) Refer to Fig H3.9. Disconnect the fluid pipe (1) from the clutch master cylinder.

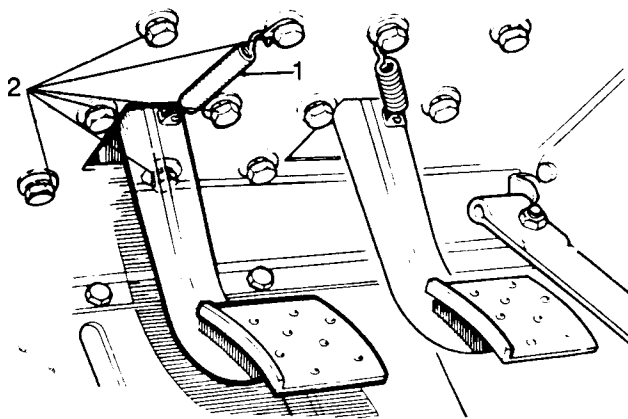

Fig H3.10

(3) Refer to Fig H3.10. Disconnect the return spring (1) from the pedal.

(4) From inside the cab remove the six fixing bolts (2) securing the clutch pedal bracket.

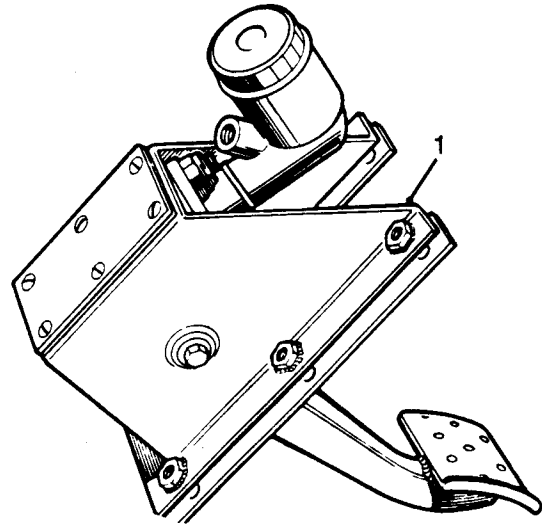

Fig 3.11

(5) Refer to Fig H3.11. Withdraw the bracket (1) complete with pedal and master cylinder.

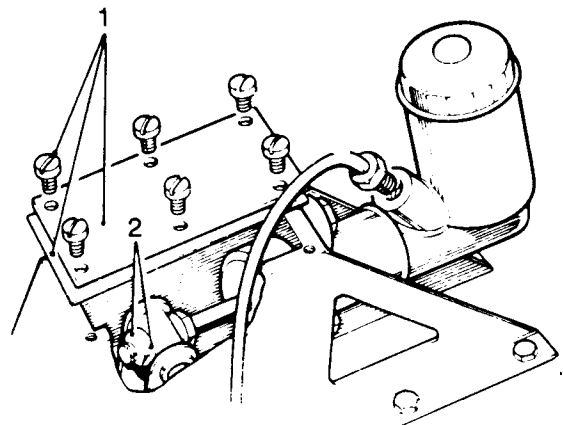

Fig H3.12

(6) Refer to Fig H3.12. Remove the top cover and gasket (1) from the clutch pedal bracket.

(7) Remove the nut (2) from the end of the master cylinder push rod and push rod into the master cylinder to clear the pedal trunnion.

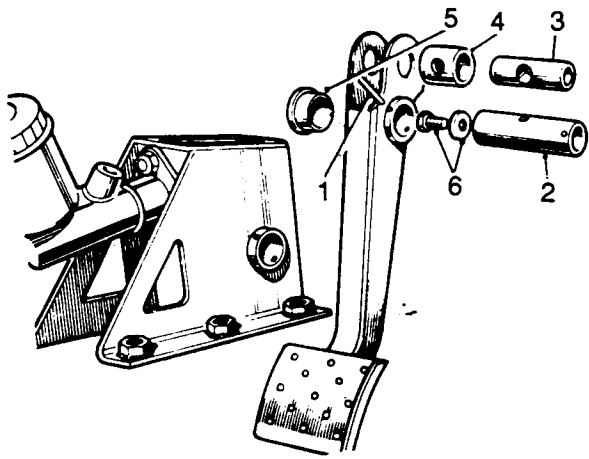

Fig H3.13

- (8) Refer to Fig H3.13. Using a suitable punch, drift out the pin (1) from the pedal shaft.
- (9) Withdraw the pedal shaft (2).
- (10) Withdraw the clutch pedal complete with trunnion (3), bush (4) and distance piece (5).
- (11) If required, remove the trunnion, bushes and distance piece from the clutch pedal.

REPLACEMENT

2. To replace the clutch pedal:

- (1) If removed, fit the distance piece (5), bush (4) and trunnion (3) to the clutch pedal. Lubricate the trunnion and distance piece with general purpose grease on assembly. New pedal bushes must be reamed to $15,87 \text{ mm} \pm 0,02 \text{ mm}$.
- (2) Remove the oil plug (6) and washer from the pedal shaft (2). Fill the shaft bore with clean engine oil and refit the plug and washer.
- (3) Replace the pedal shaft into the clutch pedal bracket.
- (4) Fit the pedal shaft (2) and replace the pin (1).

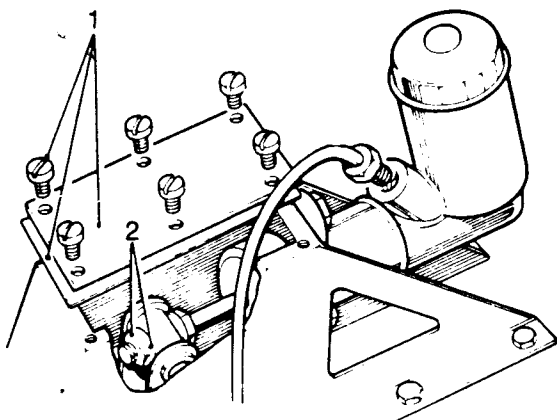

Fig H3.14

- (5) Refer to Fig H3.14. Push the master cylinder push rod through the trunnion and fit the nut (2) and washer.

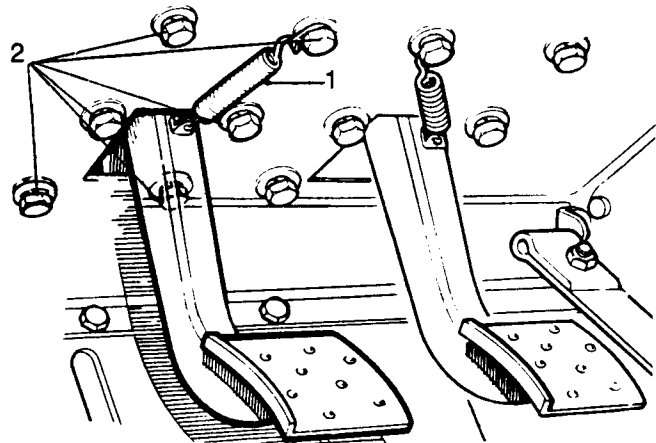

Fig H3.15

- (6) Refer to Fig H3.15. Fit the clutch pedal bracket complete with pedal and master cylinder and secure from inside cab with six fixing bolts (2).
- (7) Refit the clutch return spring (1).

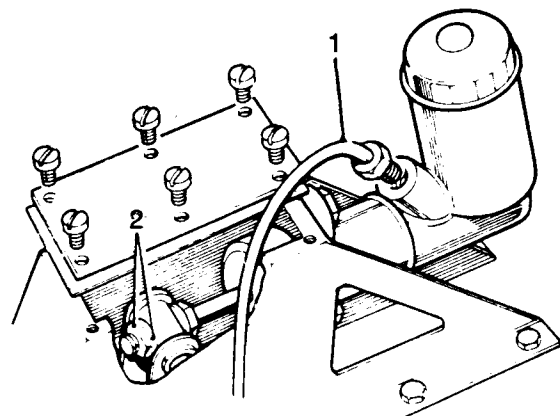

Fig H3.16

- (8) Refer to Fig H3.16. Refit the fluid pipe (1) to the clutch master cylinder.
- (9) Bleed the system (see Sub-sub-section H3.6).
- (10) Set the clutch pedal and master cylinder (see Sub-sub-section H3.3).

SUB-SUB-SECTION CONTENTS LIST

SUB-SUB-SECTION H3.5

OVERHAUL PROCEDURES

CHAPTER	DESCRIPTION	PAGE
1	MASTER CYLINDER - OVERHAUL	H3.21
2	SLAVE CYLINDER - OVERHAUL	H3.24

SUB-SUB-SECTION H3.5

CHAPTER 1

MASTER CYLINDER OVERHAUL

DISMANTLING

1. First dismantle the master cylinder:

- (1) Remove the master cylinder (see Sub-sub-section H3.4, Chapter 2).

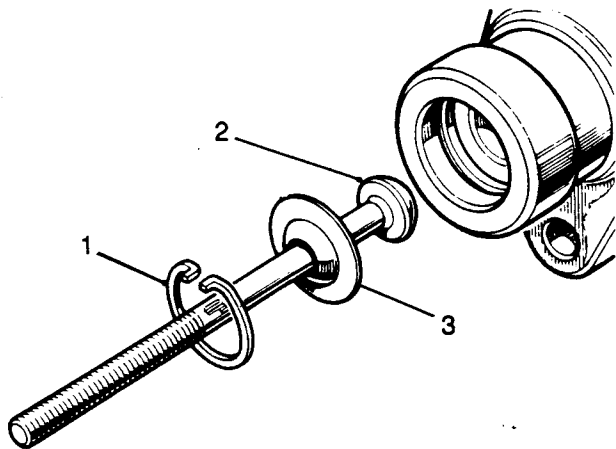

Fig H3.17

- (2) Refer to Fig H3.17. Remove the circlip (1).
(3) Withdraw the push rod (2) and retaining washer (3).

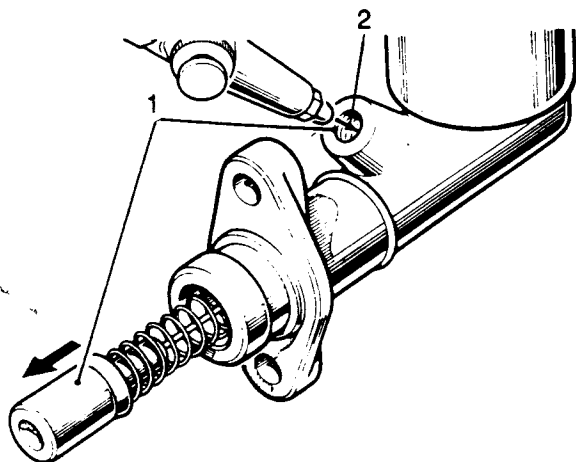

Fig H3.18

- (4) Refer to Fig H3.18. Withdraw the piston assembly (1). If necessary apply a low air pressure to the fluid outlet port (2) to expel the piston.

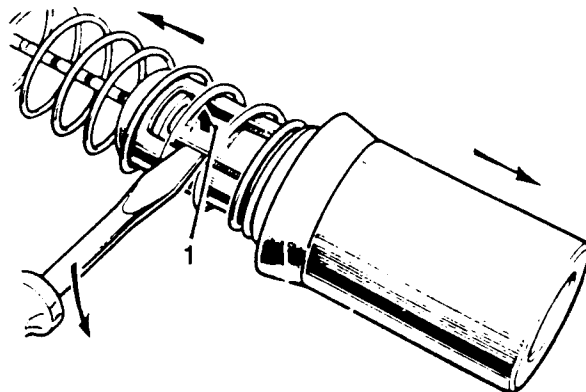

Fig H3.19

- (5) Refer to Fig H3.19. Prise the locking prong (1) of the spring retainer clear of the piston shoulder and withdraw the piston.
(6) Withdraw the piston seal.

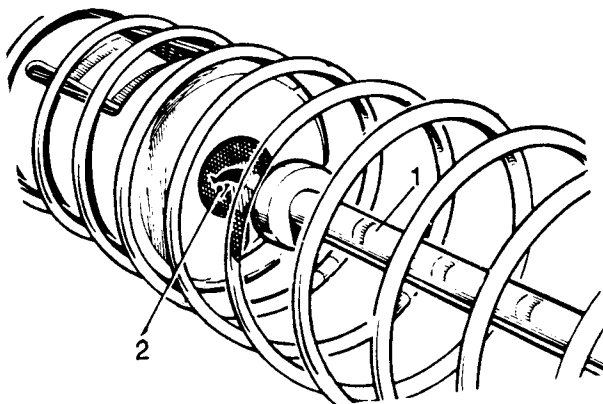

Fig H3.20

- (7) Refer to Fig H3.20. Compress the spring and position the valve stem (1) to align with the larger hole (2) in the spring retainer.

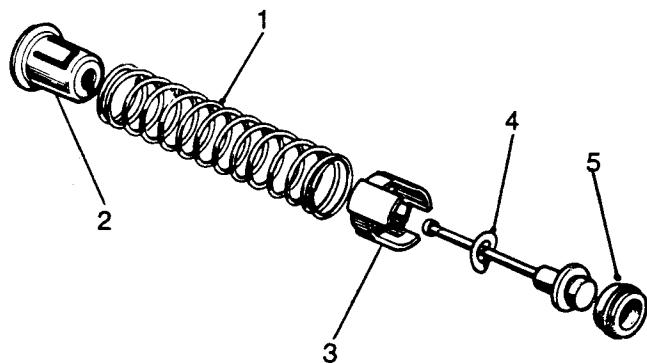

Fig H3.21

- (8) Refer to Fig H3.21. Withdraw the spring (1) and retainer (2).
- (9) Withdraw the valve spacer (3) and spring washer (4) from the valve stem.
- (10) Remove the valve seal (5).

INSPECTING

- 2. Inspect the master cylinder components:
 - (1) Clean all components in Girling cleaning fluid and allow to dry.
 - (2) Examine the cylinder bore and piston. Ensure that they are smooth to the touch with no corrosion, score marks or ridges. If there is any doubt, replace with new components.
 - (3) Discard all seals and fit new ones.

REASSEMBLY

- 3. Reassemble the master cylinder as detailed below:
 - (1) Apply a smear of Castrol-Girling rubber grease to the seals.
 - (2) Smear the remaining internal components with Castrol-Girling brake and clutch fluid.

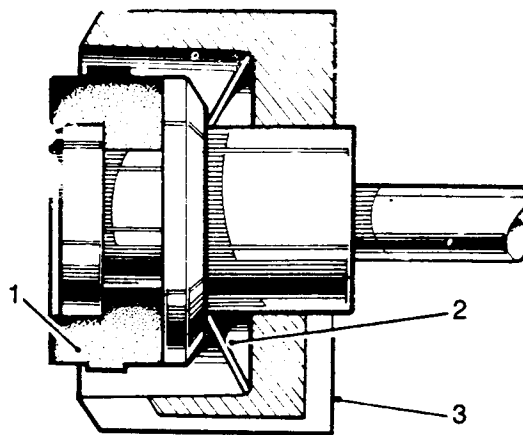

Fig H3.22

- (3) Refer to Fig H3.22. Fit the valve seal (1), flat side first, on to the end of the valve stem (2).
- (4) Fit the spacer (3), legs first.

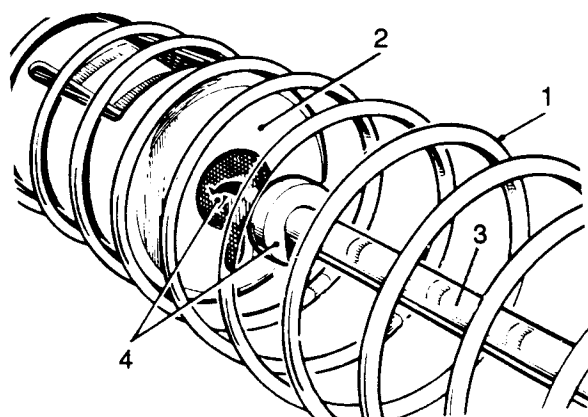

Fig H3.23

- (5) Refer to Fig H3.23. Place the coil spring (1) over the valve stem.
- (6) Insert the retainer (2) into the spring.
- (7) Compress the spring and engage the valve stem (3) in the keyhole slot (4) in the retainer.

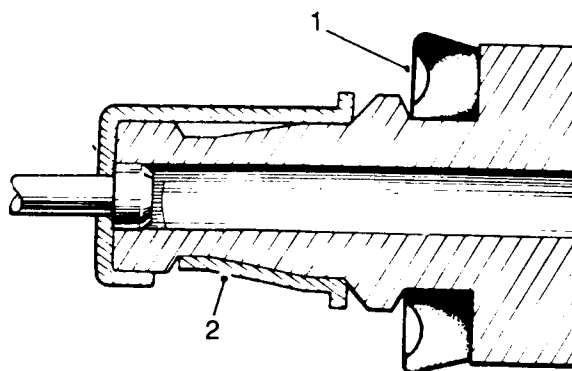

Fig H3.24

- (8) Refer to Fig H3.24. Fit the seal (1), large diameter last, to the piston.
- (9) Insert the piston into the spring retainer and engage the locking prong (2).

(10) Smear the piston with Castrol-Girling rubber grease and insert the assembly, valve end first, into the cylinder.

(12) Replace the master cylinder as detailed in Sub-sub-section H3.4, Chapter 2.

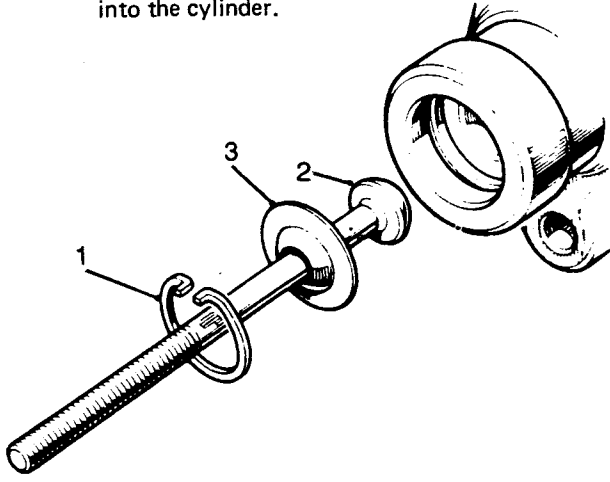

Fig H3.25

(11) Refer to Fig H3.25. Fit the push rod (2) retaining washer (3) and circlip (1).

SUB-SUB-SECTION H3.5

CHAPTER 2

SLAVE CYLINDER OVERHAUL

DISMANTLING

1. To dismantle the slave cylinder:
 - (1) Remove the slave cylinder (see Sub-sub-section H3.4, Chapter 3).

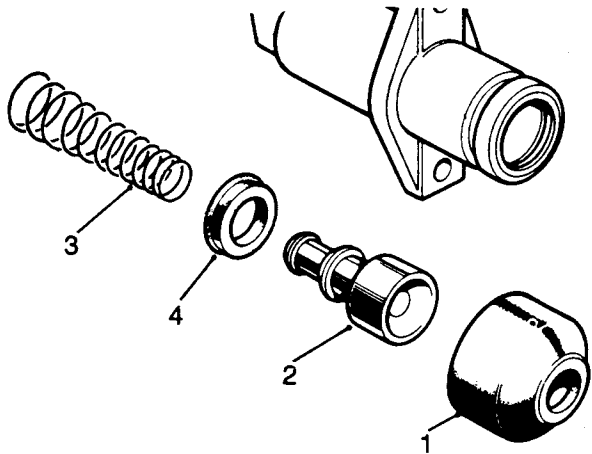

Fig H3.26

- (2) Refer to Fig H3.26. Withdraw the dust cover (1).
- (3) Expel the piston assembly (2) by applying low pressure air to the fluid inlet.
- (4) Withdraw the spring (3).
- (5) Remove the seal (4) from the piston.

INSPECTION

2. Inspect the slave cylinder components:
 - (1) Clean all components in Girling cleaning fluid and allow to dry.
 - (2) Examine the cylinder bore and the piston. Ensure that they are smooth to the touch with no corrosion, score marks or ridges. If there is any doubt, replace with new components.
 - (3) Discard the seal and replace with a new one.

REASSEMBLY

3. Reassemble the slave cylinder as follows:
 - (1) Apply a smear of Castrol-Girling rubber grease to the seal.
 - (2) Smear the remaining internal components with Castrol-Girling brake and clutch fluid.
 - (3) Fit the seal (4), large diameter last, to the piston (2).
 - (4) Locate the conical spring (3), small diameter first, over the end of the piston.
 - (5) Smear the piston with Castrol-Girling rubber grease and insert the assembly, spring end first, into the cylinder.
 - (6) Fill the dust cover (1) with Castrol-Girling rubber grease and fit the cover to the cylinder.
 - (7) Refit the slave cylinder (see Sub-sub-section H3.4, Chapter 3).

SUB-SUB-SECTION H3.6

MAINTENANCE

GENERAL

1. The fluid level in the reservoir on the master cylinder must be checked at regular intervals and topped up if necessary. Only use the specified hydraulic fluid in the reservoir.
2. Periodically, check the master and slave cylinders and the hydraulic pipe between the two for leaks. Since leaking components can allow air to enter the system, remedial action must be taken immediately a leak is found.
3. Spongy operation of the clutch is a sign that air has entered the system. When the driver becomes aware of a spongy feeling when operating the clutch the system should first be checked for leaks. If there is a leak this should be repaired. If there is no leak or after repair or replacement of any clutch component the hydraulic system must be bled (see below).

BLEEDING THE SYSTEM

4. To bleed the clutch hydraulic system:

NOTE

During the following procedure keep the fluid reservoir topped up to avoid introducing further air into the system. Use only the recommended type of hydraulic fluid.

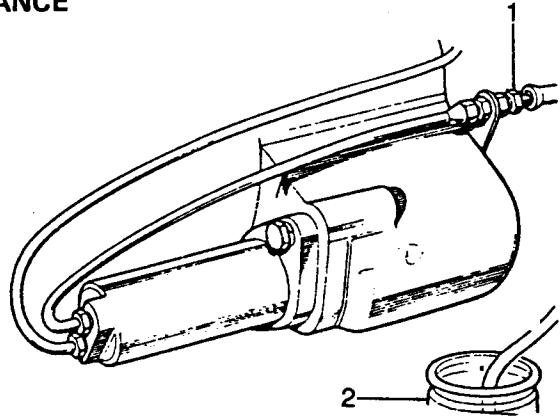

Fig H3.27

- (1) Refer to Fig H3.27. Attach a length of suitable tubing to the slave cylinder bleed screw (1).
- (2) Place the free end of the tube into a clean glass jar (2) containing clutch fluid.
- (3) Slacken the bleed screw.
- (4) Pump the clutch pedal, pausing at the end of each stroke, until the fluid issuing from the tube is free from air with the tube free end below the surface of the fluid in the jar.
- (5) Hold the tube free end immersed and tighten the bleed screw before starting a pedal up-stroke.

SUB-SECTION CONTENTS LIST

SUB-SECTION H4

PROPELLER SHAFTS

SUB-SUB-SECTION	DESCRIPTION	PAGE
H4.1	DESCRIPTION AND SPECIFICATIONS	H4.3
H4.2	FAULT DIAGNOSIS AND CORRECTIVE ACTION	H4.7
H4.3	REMOVAL AND REPLACEMENT PROCEDURES	H4.9
H4.4	OVERHAUL PROCEDURES	H4.11
H4.5	MAINTENANCE	H4.15

SUB-SUB-SECTION CONTENTS LIST

SUB-SUB-SECTION H4.1

DESCRIPTION AND SPECIFICATIONS

CHAPTER	DESCRIPTION	PAGE
1	DESCRIPTION	H4.5
2	PROPELLER SHAFT SPECIFICATIONS	H4.6

SUB-SUB-SECTION H4.1

CHAPTER 1

DESCRIPTION

1. Two propeller shafts are fitted, one between the transfer box and the rear axle differential and the other from the transfer box to the front axle differential.
2. Both propeller shafts incorporate splined sliding portions, the front one being covered by a flexible boot.
3. The shafts are connected to the driving and driven flanges via universal joints.

SUB-SUB-SECTION H4.1

CHAPTER 2

PROPELLER SHAFT SPECIFICATIONS

INTRODUCTION

1. General data for the propeller shafts is given in Table H4.1 below. There are no torque specifications for propeller shaft components.

TABLE H4.1 - GENERAL DATA

ITEM	DESCRIPTION
Type	Hardy-Spicer, needle bearing
Diameter of tubular shaft	50,8 mm

SUB-SUB-SECTION H4.2

FAULT DIAGNOSIS AND CORRECTIVE ACTION

INTRODUCTION

1. This sub-section deals with fault diagnosis and suggested action to cure a fault. Table H4.2 gives a list of symptoms, the probable cause and necessary remedial action. The Table is not exhaustive and faults may occur which are not listed. In this case the suspected components should be removed for closer inspection and/or overhaul.

TABLE H4.2 - PROPELLER SHAFTS FAULT DIAGNOSIS CHART

SYMPTOM	POSSIBLE CAUSE	REMEDY
Vibrating propellor shaft	Fixings loose. Incorrectly assembled propellor shaft. Worn needle roller bearings. Worn splines. Shaft out of balance.	Tighten the fixings evenly and securely. Reassemble propellor shaft correctly aligned. Fit new bearings. Fit new propeller shaft complete. Fit new propellor shaft complete.
Noisy universal joints	Lack of lubrication. Fixing loose. Worn needle roller bearings. Worn splines.	Lubricate propellor shaft. Tighten the fixings evenly and securely. Fit new bearings. Fit new propellor shaft complete.

SUB-SUB-SECTION H4.3

PROPELLER SHAFTS - REMOVAL AND REPLACEMENT

REMOVAL

1. To remove a propeller shaft:

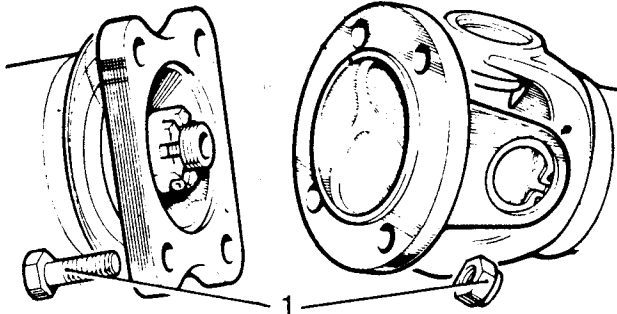

Fig H4.1

- (1) Refer to Fig H4.1. Remove the bolts and locknuts (1) from the coupling flanges at both ends of the shaft.
- (2) Withdraw the shaft.

REPLACEMENT

2. Replace a propeller shaft as detailed below:

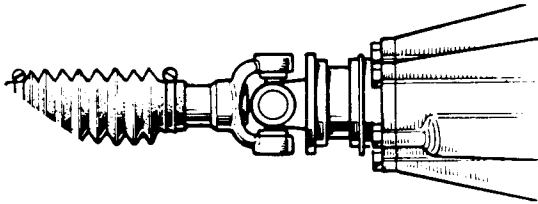

Fig H4.2

- (1) **Front propeller shaft:** Refer to Fig H4.2. Locate the shaft in position with the sleeve end towards the front axle.

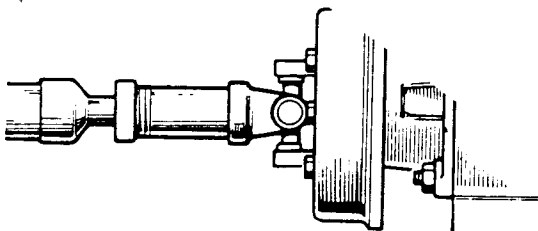

Fig H4.3

- (2) **Rear propeller shaft:** Refer to Fig H4.3. Locate the shaft in position with the sleeve end towards the gearbox.

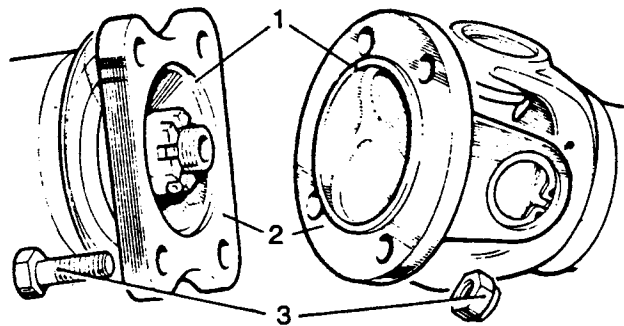

Fig H4.4

- (3) **Both shafts:** Refer to Fig H4.4. Ensure that the registers (1) on the coupling flanges (2) engage.
- (4) Secure the coupling flanges with the four bolts and locknuts (3).

SUB-SUB-SECTION H4.4

OVERHAUL PROCEDURES

DISMANTLING

1. To dismantle a propeller shaft:

- (1) Remove the propeller shaft (see Sub-sub-section H4.3).

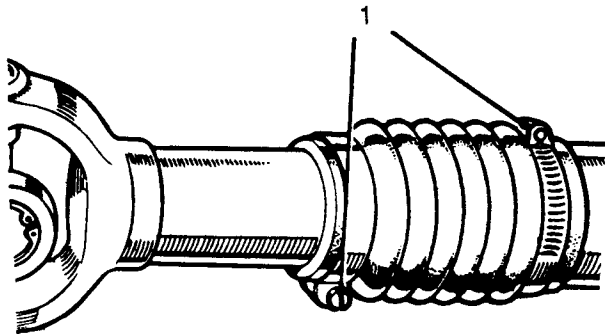

Fig H4.5

- (2) **Front propeller shaft:** Refer to Fig H4.5. Release the two hose clips (1) and slide the rubber boot along the propeller shaft.

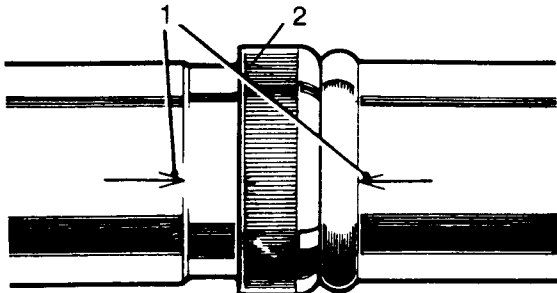

Fig H4.6

- (3) **Both shafts:** Refer to Fig H4.6. Check that the alignment marks (1) on the splined sleeve and the splined shaft are clearly visible. If necessary inscribe new alignment marks.
- (4) Unscrew the dust cap (2).
- (5) Withdraw the splined sleeve.
- (6) Clean the splined shaft and the splined sleeve in a grease solvent.
- (7) Temporarily locate the splined shaft into the sleeve, maintaining the marked alignment.

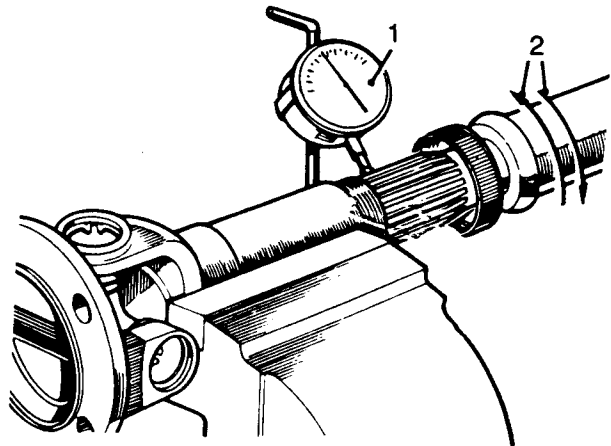

Fig H4.7

- (8) Refer to Fig H4.7. Secure the shaft in a vice.
- (9) Mount a test dial indicator (1) to read off the outside diameter of the shaft splines.
- (10) Check the circumferential movement (2) between the sleeve and shaft. If the movement exceeds 0,1 mm fit a new propeller shaft complete.

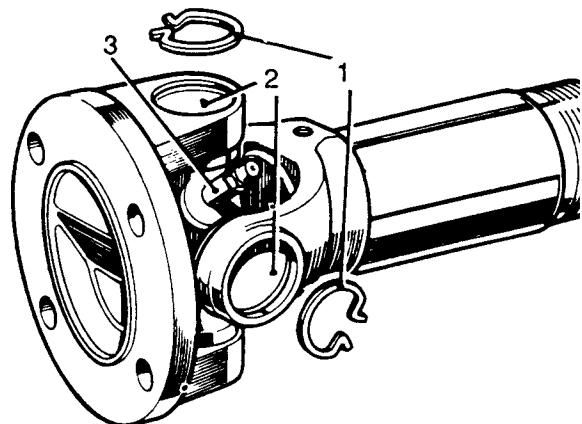

Fig H4.8

- (11) Refer to Fig H4.8. Clean any dirt and enamel from the circlips (1) and the tops of the bearing races (2).
- (12) Remove the circlips.

- (13) Remove the grease nipple (3) from the universal joint.

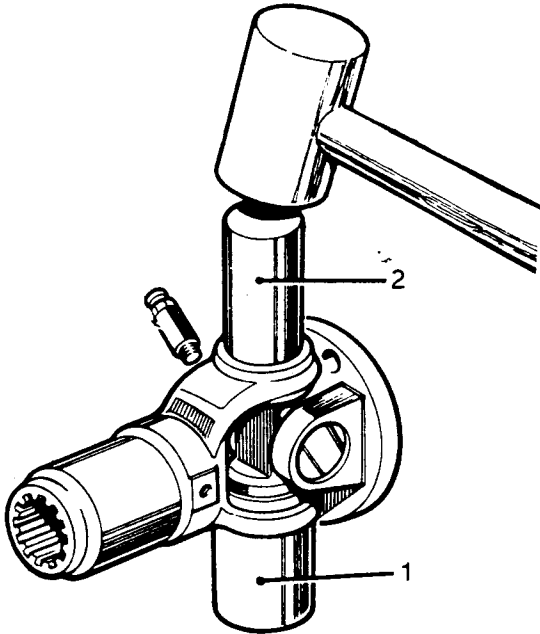

Fig H4.9

- (14) Refer to Fig H4.9. Locate the yoke of the splined sleeve onto a suitable piece of tube (1) which has a slightly larger internal diameter than the journal bearing.

- (15) Using a brass drift (2) drive the universal joint downwards until it is clear of the lower yoke.

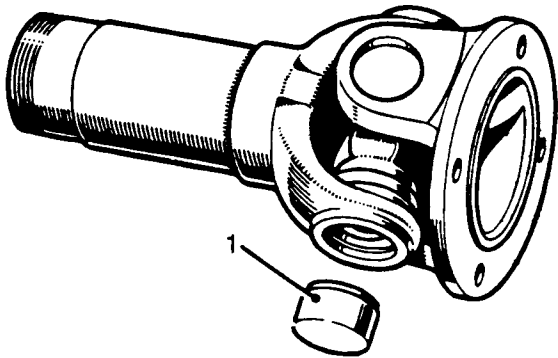

Fig H4.10

- (16) Refer to Fig H4.10. Lift the sleeve clear of the tube and withdraw the bearing (1) downwards to avoid dropping the needle rollers.

- (17) Repeat steps (14) to (16) for the opposite bearing.

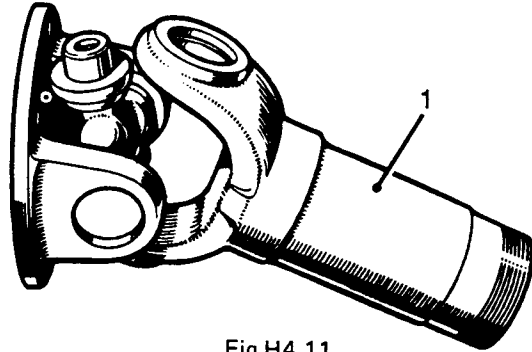

Fig H4.11

- (18) Refer to Fig H4.11. Withdraw the splined sleeve (1) from the flanged yoke.

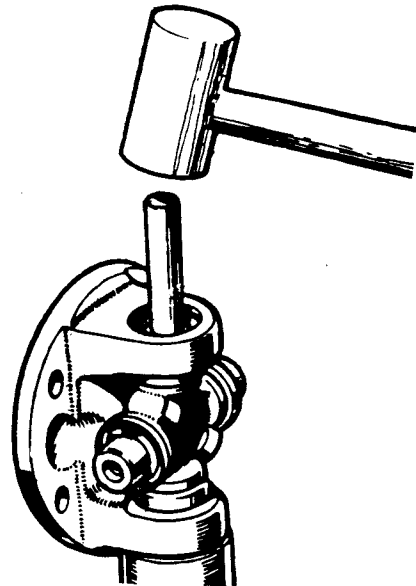

Fig H4.12

- (19) Refer to Fig H4.12. Remove the bearings from flanged yoke.

- (20) Repeat steps (14) to (19) for the splined shaft.

INSPECTING

2. Clean all components in a grease solvent and allow to dry. Make the following inspection:
 - (1) Examine all components for obvious wear and damage.
 - (2) If the journal or bearings for the universal joints show any signs of wear, load markings or distortion they must be replaced complete. Replacement journal assemblies comprise a spider complete with oil seals and bearings.
 - (3) In the event of wear in any of the eight yoke cross holes, rendering them oval, a new propeller shaft complete must be fitted.

REASSEMBLY

3. Reassemble the propeller shaft as detailed below:

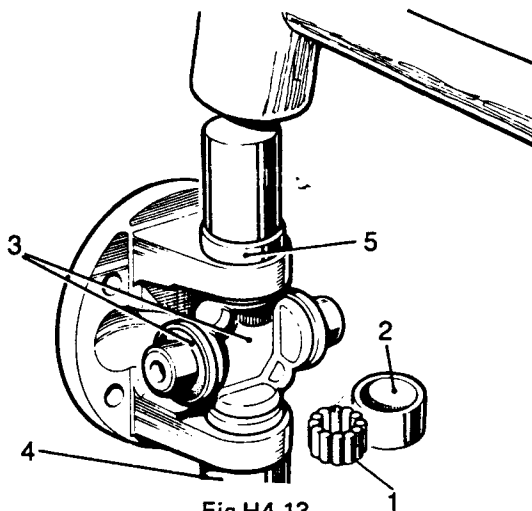

Fig H4.13

- (1) Refer to Fig H4.13. Assemble the needle rollers (1) in the bearing races (2). If necessary, use a smear of vaseline to retain them in place.
- (2) About half fill the races with a recommended grease.
- (3) Insert the journal (3), complete with seals, into the flange yoke holes with the grease nipple tapping pointing away from the flange.
- (4) Place the flanged yoke on a suitable flat support (4).
- (5) Place the first bearing (5) in position.
- (6) Using a brass drift slightly smaller in diameter than the hole in the yoke, tap the bearing into position.
- (7) Fit the circlip to retain the bearing.

NOTE

The bearing outer races must be a drive fit, otherwise fit a new propeller shaft complete.

- (8) Repeat steps (4) to (7) for the other three bearings comprising the universal joint.
- (9) Ensure that all four circlips are firmly located in their grooves. If a joint appears to bind, tap the yoke ears lightly with a soft mallet.
- (10) Repeat steps (1) to (9) for the other universal joint.
- (11) **Front propeller shaft:** Slide the rubber boot and hose clips over the splined shaft.
- (12) **Both propeller shafts:** Liberally smear the splines of the shaft and sleeve with the recommended grease.
- (13) Assemble the splined shaft and sleeve, maintaining the marked alignment.

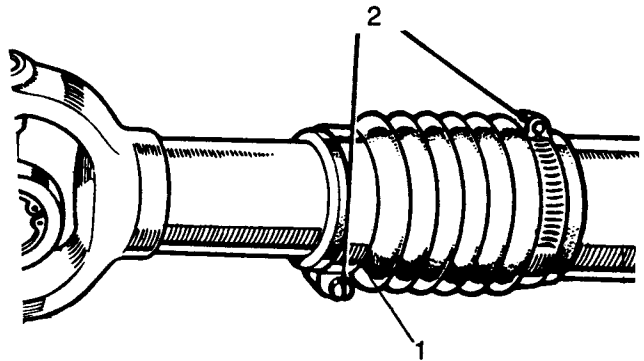

Fig H4.14

- (14) **Front propeller shaft:** Refer to Fig H4.14. Place the rubber boot (1) in position and secure the hose clips (2) 180° to each other to maintain balance.

- (15) **Both propeller shafts:** Fit the grease nipple to the universal joints and lubricate.

CAUTION

Do not fill the sliding joint with grease, use only sufficient to lubricate the splines otherwise hydrauliclocking will result.

- (16) Refit the propeller shafts (see Sub-sub-section H4.3).

SUB-SUB-SECTION H4.5

MAINTENANCE

INTRODUCTION

1. The propeller shafts and universal joints fitted to this vehicle are virtually maintenance free. They should be inspected periodically for wear and deterioration and grease should be applied at regular intervals.
2. Note that the cavity between the sliding portion and the universal joint must not be packed with grease since damage may be caused to the shafts or bearings of connected assemblies.

SPECIAL WORKSHOP TOOLS FOR SECTION H - TRANSMISSION

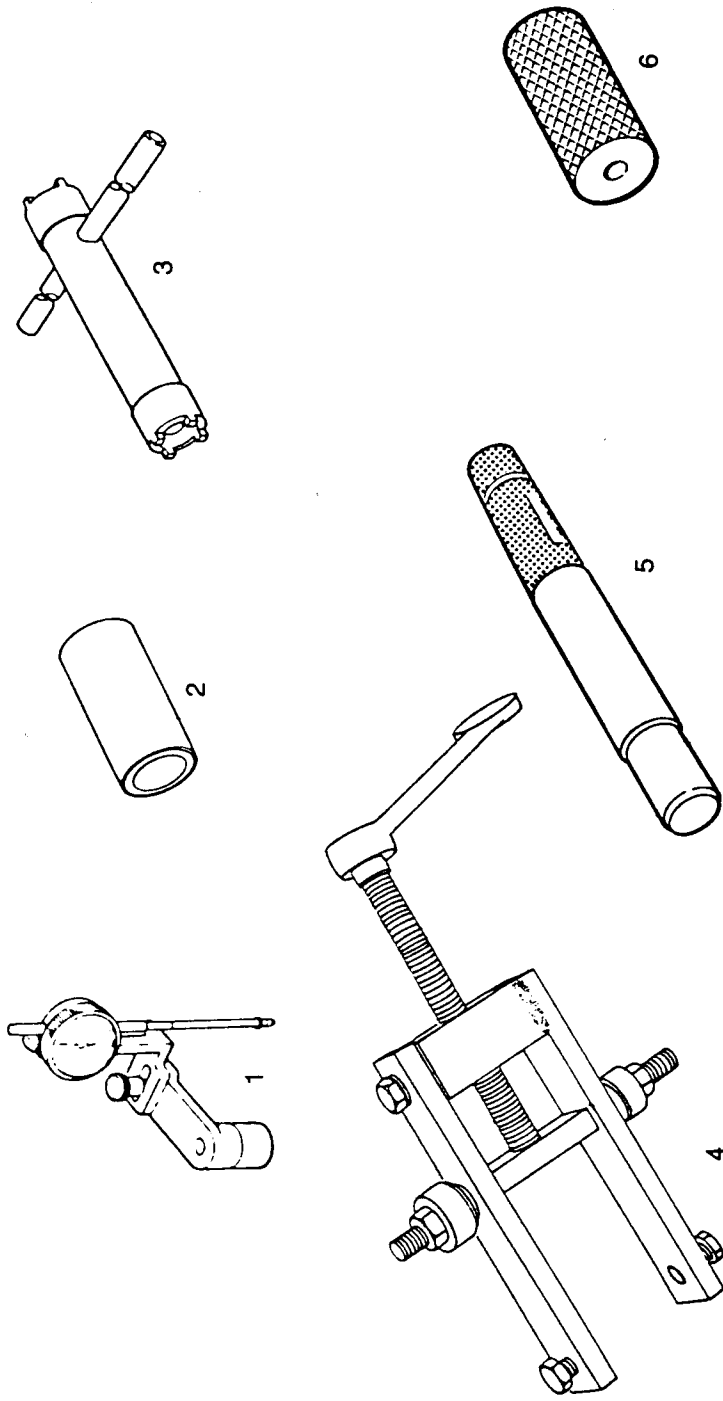

SPECIAL WORKSHOP TOOLS FOR SECTION H - TRANSMISSION

Item Ref	Mfr. Part No. & / or Drg.No. &/or Spec. No.	I. C. N.º	Item Name and Description	Items/ Unit	Repair Lines
Item Verw.	Verv. Ond. Nr. & / of Tek.Nr. &/of Spes.Nr.	I. B. N.	Itemnaam en Beskrywing	Items/ Eenhd.	Herstel Lyne 1 2 4
1	18G191		DIAL GAUGE and SUPPORT to measure layshaft constant gear end play		
2	243241		PROTECTION CAP, GEARBOX OUTPUT SHAFT to prevent thread damage		
3	600300		DOUBLE ENDED SPANNER for removing mainshaft shaft nut		
4	RO1004		REMOVER for removing mainshaft spacer		
5	18G79SA		TOOL for centralising clutch		
6	262772		TOOL for removing the intermediate shaft		

SECTION CONTENTS LIST

SECTION I

SUSPENSION SYSTEM

SUB-SECTION	DESCRIPTION	PAGE
11	DESCRIPTION AND SPECIFICATIONS	11.1
12	FAULT DIAGNOSIS AND CORECTIVE ACTION	12.1
13	CHECKS AND ADJUSTMENTS	13.1
14	REMOVAL AND REPLACEMENT PROCEDURES	14.1
15	OVERHAUL OF A ROAD SPRING ASSEMBLY	15.1
16	MAINTENANCE	16.1
17	SPECIAL WORKSHOP TOOLS	17.1

SUB-SECTION CONTENTS LIST

SUB-SECTION 11

DESCRIPTION AND SPECIFICATIONS

CHAPTER	DESCRIPTION	PAGE
1	DESCRIPTION OF THE SUSPENSION SYSTEM	11.3
2	SPECIFICATIONS FOR THE SUSPENSION SYSTEM	11.4

SUB-SECTION I1

CHAPTER 1

DESCRIPTION OF THE SUSPENSION SYSTEM

GENERAL

1. The Land Rover is a four wheel drive vehicle, therefore the drive must be transmitted to two axles, front and rear.
2. The front axle combines the function of the steering and driving unit. A differential, similar to that fitted to the rear axle, accepts the power input from the propeller shaft connected to the front of the transfer box and transmits it via a universally jointed shaft to the front wheels. Steering and braking functions are accomplished by swivelling stub axles mounted in housings.

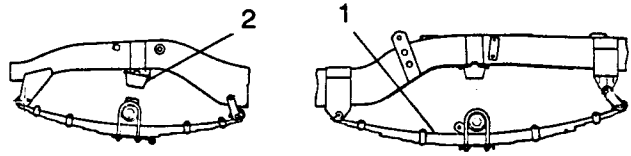

Fig I1.1

3. The suspensions, front and rear, are by semi-elliptical leaf springs (1) damped by hydraulic dampers mounted between axle and chassis frame. Differential units are fitted to both front and rear axles.
4. Rubber shock absorbers (2) prevent excessive upward travel of the axles against the springs.

SUB-SECTION 11

CHAPTER 2

SPECIFICATIONS FOR THE SUSPENSION SYSTEM

INTRODUCTION

1. The specifications are given in the following Tables:

TABLE 11.1 - GENERAL DATA
TABLE 11.2 - TORQUE SPECIFICATIONS

TABLE 11.1 - GENERAL DATA

ITEM	DESCRIPTION
Type of springs	Semi elliptical leaf
Number of leaves:	
Front	4
Rear	8
Free camber:	
Front springs	150 mm
Rear springs	170 mm
Shock absorbers	Double acting, hydraulic telescopic type. Non adjustable

TABLE 11.2 - TORQUE SPECIFICATIONS

ITEM	TORQUE (N.m)
Shackle pins	96
'U' bolt nuts	50 to 60

SUB-SECTION 12

FAULT DIAGNOSIS AND CORRECTIVE ACTION

INTRODUCTION

1. This Sub-section deals with fault diagnosis and the corrective action required for the suspension. In Table 12.1, a list of symptoms, the probable cause and the necessary remedies are given. If a fault is suspected, the faults listed in the accompanying Table should be consulted. It should be remembered that the Table is not exhaustive and, therefore, faults may occur which are not listed. Should this fail to reveal the fault, remove the suspect component/s for a closer inspection and/or overhaul of components.

TABLE 12.1 - SUSPENSION FAULT DIAGNOSIS CHART

SYMPTOM	POSSIBLE CAUSE	REMEDY
Vehicle leaning to one side	Broken main leaf spring. Spring/s sagged (collapsed). Heavy load not centralised on load body.	Replace leaf spring. Replace complete spring/s. Educate loading personnel.
Poor directional (stability) control	Leaf clip bolts loose. Shock absorber/s leaking. Shock absorber mounting bracket broken. Broken centre bolt/s.	Replace worn or damaged bolts then torque tighten the bolts. Replace shock absorber/s. Replace mounting bracket. Replace centre bolt/s.
Bumpy (harsh) ride	Shock absorber seized or bent. Vehicle overloaded. Springs sagged (collapsed).	Replace shock absorber. Educate loading personnel. Replace complete spring.
Vehicle leaning excessively during cornering	Spring/s sagged (collapsed). Vehicle overloaded.	Replace complete spring/s. Educate loading personnel.

SUB-SECTION CONTENTS LIST

SUB-SECTION I3

CHECKS AND ADJUSTMENTS

CHAPTER	DESCRIPTION	PAGE
1	CHECKING TRIM HEIGHT	13.3
2	SPRING SETTING PROCEDURE	13.4
3	CHECKING SHOCK ABSORBER OPERATION	13.5

SUB-SECTION I3

CHAPTER 1

CHECKING TRIM HEIGHT

GENERAL

1. The road springs differ in spring rating according to their fitting position and no adjustment is provided. An incorrect replacement spring or incorrect fitting procedure can adversely affect the vehicle trim; check before replacing parts.

CHECKING PROCEDURE

2. Check trim height as follows:

- (1) Position the vehicle on firm level ground.
- (2) Ensure that the vehicle is in the static, unladen weight condition, that is with a full coolant and lubrication system and 22,5 litres of fuel.
- (3) Check and if necessary adjust tyres to recommend pressures.

3. Where the measurements are not within these limits:

- (1) Check that the correct springs are fitted. The spring part number is marked on the spring top face and also on the underside of one of the leaves.
- (2) If the springs are correct, jack up the vehicle and take the weight off the road springs.
- (3) Remove the shackle pins and ensure that they are a free fit in the shackle plate threads and not binding in the shackle pin bushes. Lubricate or polish to achieve this condition.
- (4) Deflect the springs and torque the pins as detailed in Sub-section I3, Chapter 2.
- (5) Lower the vehicle and recheck trim height.

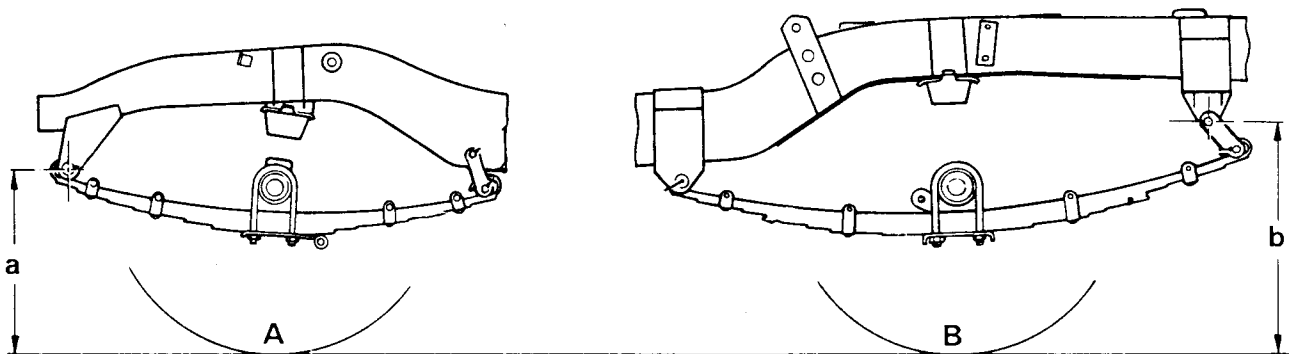

Fig I3.1

- (4) Refer to Fig I3.1. Measure the distance from the ground to the shackle pin centres on both front and both rear wheels (measurements 'a' for the front wheels and 'b' for the rear wheels). The two 'a' measurements shall be the same to within 25 mm. The two 'b' measurements shall be the same to within 25 mm.

SUB-SECTION I3

CHAPTER 2

SPRING SETTING PROCEDURE

GENERAL

1. In the following procedure, the spring shackles are tightened onto the shackle bushes whilst in their approximate working positions thus minimising the torque load on the shackle bush rubbers when the vehicle weight is taken on the springs and so prolonging the bush working life.

(2) With the springs held in position, tighten first the shackle pin then the locknut. Torque 96 N.m.

(3) Replace the springs as in Sub-section 14, Chapter 1, para 2, step (8) onwards.

SETTING

2. This operation should normally be carried out during the replacement of a spring (see Sub-section 14, Chapter 1).

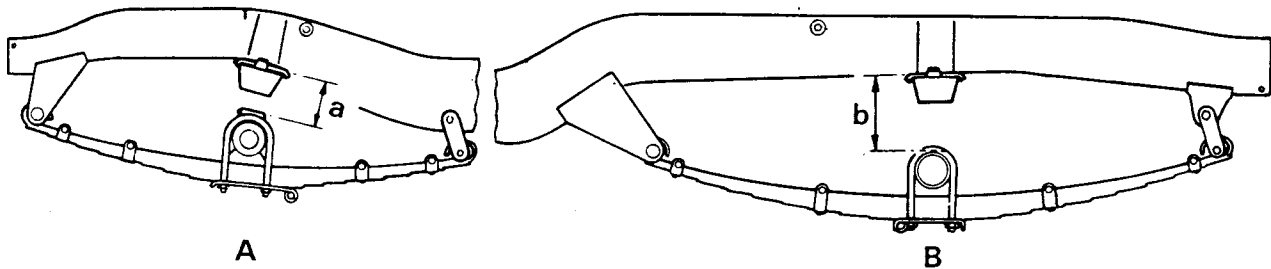

A
Fig 13.2

(1) Refer to Fig 13.2. Deflect the spring (A front spring, B rear spring) toward the chassis, using a suitable chain and lever, until the following dimensions are obtained.

Front springs - 95 mm (dimension 'a')
Rear springs - 151 mm (dimension 'b')

SUB-SECTION I3

CHAPTER 3

CHECKING SHOCK ABSORBER OPERATION

1. To check a shock absorber:

(1) Remove the shock absorber from the vehicle (see Sub-section 14, Chapter 2).

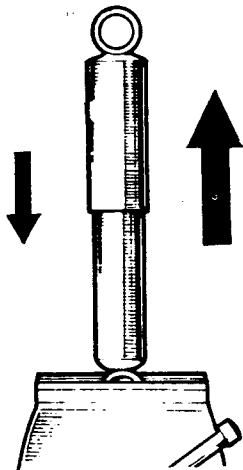

Fig I3.3

(2) Refer to Fig I3.3. Secure the shock absorber vertically in a vice by holding the bottom fixing between the jaws.

(3) The shock absorber incorporates differential damping, having greater resistance on the extension stroke. Check the operation by extending and compressing the shock absorber, there must be a uniform resistance throughout the length of the stroke. If the resistance is erratic or weak, fit a new shock absorber.