

SUB-SUB-SECTION H1.4

CHAPTER 8

MAIN GEAR LEVER - DISMANTLING AND REASSEMBLY

DISMANTLING

1. To strip the gear lever:
 - (1) Remove the gear lever (see Sub-sub-section H1.3, Chapter 3).

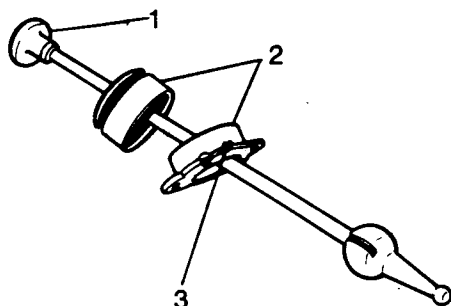

Fig H1.159

- (2) Refer to Fig H1.159. Remove the knob and fixing nut (1).
- (3) Remove the support and dust cover (2) from the ball joint.
- (4) Remove the fixing screw (3).

INSPECTION

2. Inspect as follows:

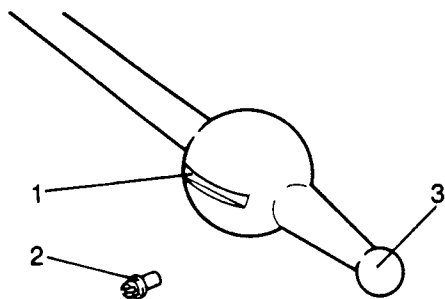

Fig H1.160

- (5) Refer to Fig H1.160. Inspect for wear the fixing groove (1) for the gear lever.
- (6) Inspect the fixing screw (2).
- (7) Inspect the selector finger (3) of the gear lever for wear.
- (8) Replace damaged or worn items.

REASSEMBLY

3. Carry out the following when reassembling the gear lever:

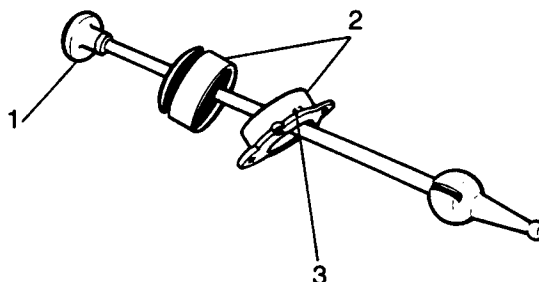

Fig H1.161

- (1) Refer to Fig H1.161. Replace the fixing screw (3).
- (2) Replace the dust cover and support (2) onto the ball joint.
- (3) Replace the fix ring nut and knob (1).
- (4) Refit the gear lever to the gearbox (see Sub-sub-section H1.3, Chapter 3).

SUB-SUB-SECTION H1.5

MAINTENANCE

INTRODUCTION

1. The gearbox is designed for maintenance free operation, requiring only periodic inspections for obvious defects and checking of the oil level. At intervals specified, the oil should be drained and replenished with fresh, clean oil of the correct grade.
2. At frequent intervals, depending on operating conditions, the exterior of the gearbox should be cleaned to prevent the accumulation of dirt, mud and oil, etc.

OIL CHECKING AND CHANGING

Checking Gearbox Oil Level

NOTE

The vehicle must be parked on a completely level surface when checking or changing the oil.

3. To check the oil level:

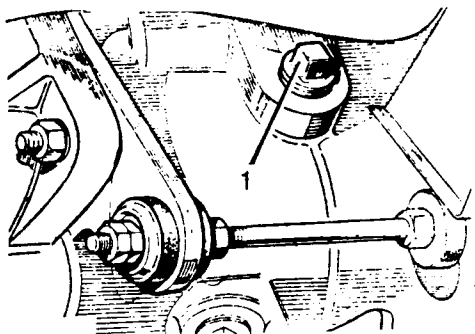

Fig H1.162

- (1) Refer to Fig H1.162. Remove the filler level plug (1).
- (2) Check that the oil is up to the bottom of the filler plug hole.
- (3) If necessary pour oil into the filler plug hole to bring the oil up to this level.
- (4) Allow excess oil to drain off through the filler hole.
- (5) Replace and tighten the filler level plug.
- (6) Wipe off any excess oil around the plug.

NOTE

If significant topping up is required check for oil leaks at the drain and filler plugs, all joint faces and through the drain hole in the bell housing.

Changing Gearbox Oil

NOTE

Before changing the oil the vehicle shall have been driven sufficiently to warm up the oil in the gearbox.

4. To change the oil in the gearbox:

- (1) Place a container under the gearbox of sufficient capacity to hold 2 litres of old oil.

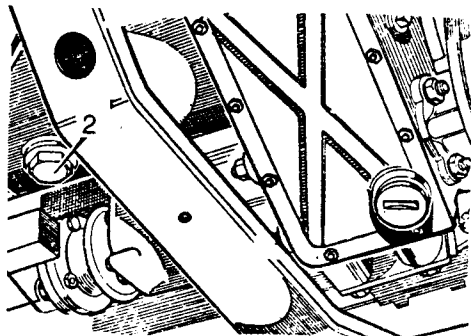
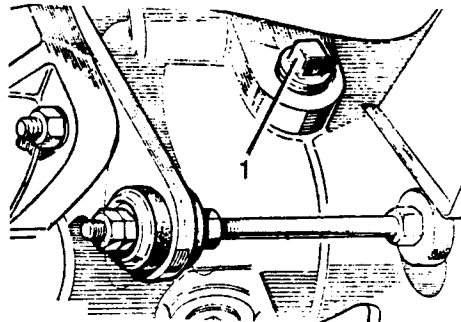

Fig H1.163

- (2) Refer to Fig H1.163. Remove the gearbox filler plug (1).
- (3) Remove the gearbox drain plug (2) and allow the oil to drain into the container.
- (4) Replace and tighten the drain plug using a new gasket.
- (5) Fill the gearbox with oil through the filler hole until the oil level is up to the bottom of the filler hole.
- (6) Allow excess oil to drain from the filler hole.
- (7) Replace and tighten the filler hole plug.
- (8) Wipe off excess oil from around the plugs.

SUB-SECTION CONTENTS LIST

SUB-SECTION H2

TRANSFER BOX

| SUB-SUB-SECTION | DESCRIPTION | PAGE |
|-----------------|---|-------|
| H2.1 | DESCRIPTION AND SPECIFICATIONS | H2.3 |
| H2.2 | FAULT DIAGNOSIS AND CORRECTIVE ACTION | H2.7 |
| H2.3 | REMOVAL AND REPLACEMENT PROCEDURES | H2.9 |
| H2.4 | TRANSFER BOX - OVERHAUL | H2.17 |
| H2.5 | MAINTENANCE | H2.21 |
| H2.6 | SPECIAL WORKSHOP TOOLS (see Sub-Section H5) | |

SUB-SUB-SECTION CONTENTS LIST

SUB-SUB-SECTION H2.1

DESCRIPTION AND SPECIFICATIONS

| CHAPTER | DESCRIPTION | PAGE |
|----------------|---------------------------------|-------------|
| 1 | DESCRIPTION OF THE TRANSFER BOX | H2.5 |
| 2 | TRANSFER BOX SPECIFICATIONS | H2.6 |

SUB-SUB-SECTION H2.1

CHAPTER 1

DESCRIPTION

1. The transfer box transfers the drive from the gear-box to the front and rear axles and provides high and low ranges to suit a variety of off- and on-road conditions.

SUB-SUB-SECTION H2.1

CHAPTER 2

TRANSFER BOX SPECIFICATIONS

INTRODUCTION

1. Specifications for the transfer box are given in the following Tables:

TABLE H2.1 - GENERAL DATA
TABLE H2.2 - TORQUE SPECIFICATIONS

TABLE H2.1 - GENERAL DATA

| ITEM | | DESCRIPTION | |
|---|---------|---|--------------|
| Type | | Two speed reduction on main gearbox output | |
| Front wheel drive | | Two/four wheel drive control on transfer box output | |
| Overall ratios (final drive) with helical and spur gear transfer gearbox: | | | |
| | | High Transfer | Low Transfer |
| Top | 5,4:1 | 11,1:1 | |
| Third | 8,05:1 | 16,5:1 | |
| Second | 12,0:1 | 24,6:1 | |
| First | 19,88:1 | 40,7:1 | |
| Reverse | 21,6:1 | 44,3:1 | |

TABLE H2.2 - TORQUE SPECIFICATIONS

| ITEM | TORQUE (N.m) |
|--|--------------|
| Transfer box double intermediate gear nut | 20 to 25 |
| Front output shaft casing to transfer box nuts | 12 to 17 |
| Speedometer drive housing to transfer box nuts | 20 to 30 |
| Transfer box lower cover nuts | 7,5 to 12,5 |

SUB-SUB-SECTION H2.2

FAULT DIAGNOSIS AND CORRECTIVE ACTION

INTRODUCTION

1. Faults on the transfer box are dealt with in this Sub-sub-section. In Table H2.3 a list of symptoms, probable causes and the necessary remedies are given. It should be noted that the Table is not exhaustive and that faults may occur which are not listed. Should the fault not be found by consulting the Table the transfer box should be overhauled.

TABLE H2.3 - TRANSFER BOX FAULT DIAGNOSIS CHART

| SYMPTOM | POSSIBLE CAUSE | REMEDY |
|----------------------------------|---|--|
| Noisy transfer box | Excessive end float of intermediate gear. End float on output shaft incorrect. Worn bearings. Low oil level. | Overhaul transfer box. Overhaul transfer box. Replace bearings. Fill transfer box to correct level. |
| Jumping out of high transfer | Selector spring weak. | Replace spring. |
| Jumping out of low transfer | Transfer fork assembled wrongly. Excessive end float of intermediate gear. Selector spring weak. | Overhaul transfer box. Overhaul transfer box. Replace spring. |
| Four-wheel drive will not engage | Return spring below yellow knob wrongly adjusted. Shafts sticking in casing. | Correct the adjustment. Overhaul transfer box. |

SUB-SUB-SECTION CONTENTS LIST

SUB-SUB-SECTION H2.3

REMOVAL AND REPLACEMENT PROCEDURES

| CHAPTER | DESCRIPTION | PAGE |
|---------|---|-------|
| 1 | TRANSFER BOX - REMOVAL AND REPLACEMENT OF THE VEHICLE | H2.11 |
| 2 | TRANSFER BOX - REMOVAL AND REPLACEMENT OUT OF THE VEHICLE | H2.13 |
| 3 | DOUBLE INTERMEDIATE GEAR - REMOVAL AND REPLACEMENT | H2.14 |

SUB-SUB-SECTION H2.3

CHAPTER 1

TRANSFER BOX - REMOVAL AND REPLACEMENT ON THE VEHICLE

REMOVAL

1. The transfer box may be removed without removing the gearbox. To do so:
 - (1) Drain the oil from the transfer box (see Sub-sub-section H2.5).
 - (2) Disconnect the front propeller shaft from the output shaft flange (see Sub-sub-section H4.3).
 - (3) Remove the rear propeller shaft (see Sub-sub-section H4.3).
 - (4) Remove the speedometer cable (see Sub-sub-section H1.3, Chapter 19).
 - (5) Remove the transmission brake coupling mechanism.
 - (6) Remove the fixings of the rear transfer box mountings.

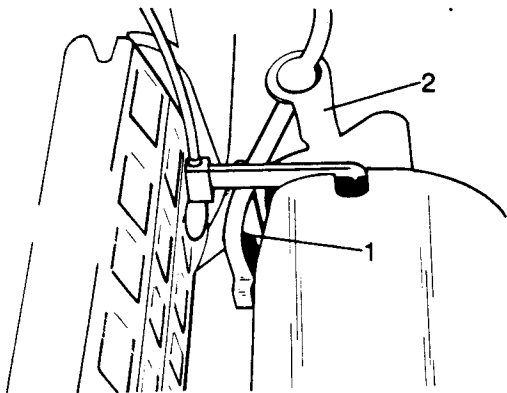

Fig H2.1

- (7) Refer to Fig H2.1. Remove the transfer box gear lever (1) from its bracket fixed to the clutch housing.
- (8) Remove the link (2) that joins the lever of the transfer box to the high and low gear selector. Take care not to lose the spring.
- (9) Remove the yellow knob, nut and spring of the selector lever for four wheel drive.
- (10) From inside the vehicle, remove the seat base centre plate, the plate of the RH floor and gearbox tunnel.
- (11) Remove the transmission brake assembly (see Sub-sub-section K2.4, Chapter 2).
- (12) Remove the double intermediate transfer box gear (see Sub-sub-section H2.3, Chapter 3).

- (13) With a hydraulic jack supporting the rear part of the engine, lift this sufficiently so that the transfer box mountings separate from the chassis.

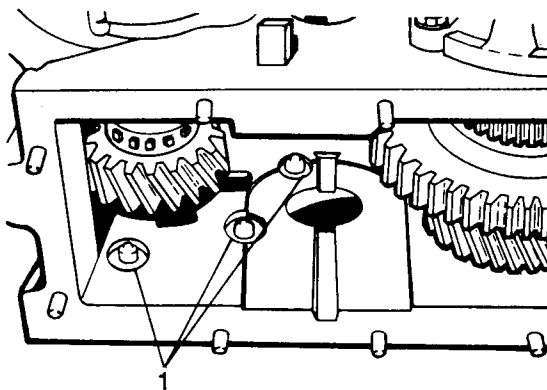

Fig H2.2

- (14) Refer to Fig H2.2. Remove the fixing elements (1) that join the transfer box to the gearbox and remove the transfer box and washer.

REPLACEMENT

2. To replace the transfer box:
 - (1) Apply a film of sealing compound Hermetical 600 on both faces of the washer which is fitted between the transfer box and gearbox.
 - (2) Fit the washer and transfer box to the gearbox. Tighten the fixing nuts to 20 to 30 N.m.
 - (3) Lower the hydraulic jack until the transfer box mountings are on the chassis.
 - (4) Replace the double intermediate transfer box gear (see Sub-sub-section H2.3, Chapter 3).
 - (5) Refit the transmission brake assembly (see Sub-sub-section K2.4, Chapter 2).
 - (6) Inside the vehicle replace the gearbox tunnel, the plate of the RH floor and the seat base centre plate.
 - (7) Replace the yellow knob, nut and spring of the four wheel drive selector lever.

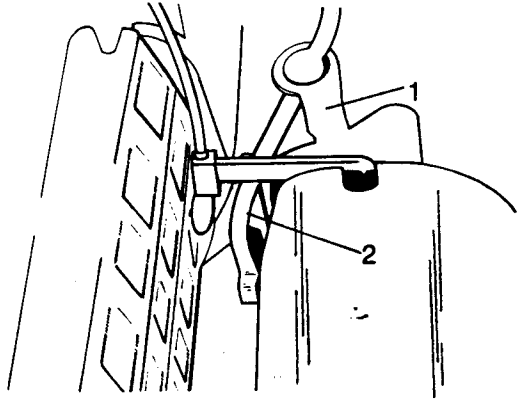

Fig H2.3

(8) Refer to Fig H2.3. Replace the link (2) and spring that join the lever of the transfer box to the high and low gear selector.

- (9) Refit the transfer box gear lever (1) into the bracket fixed to the clutch housing.
- (10) Replace the fixings of the rear transfer box mountings.
- (11) Refit the transmission brake coupling mechanism.
- (12) Replace the speedometer cable.
- (13) Refit the front and rear propeller shafts (see Sub-sub-section H4.3).
- (14) Fill the transfer box with the correct grade of oil (see Sub-sub-section H2.5).

SUB-SUB-SECTION H2.3

CHAPTER 2

TRANSFER BOX - REMOVAL AND REPLACEMENT OUT OF THE VEHICLE

REMOVAL

1. Separate the transfer box from the gearbox as follows:
 - (1) Remove the gearbox from the vehicle (see Sub-sub-section H1.3, Chapter 1).
 - (2) Remove the double intermediate gear from the transfer box (see Sub-sub-section H2.3, Chapter 3).

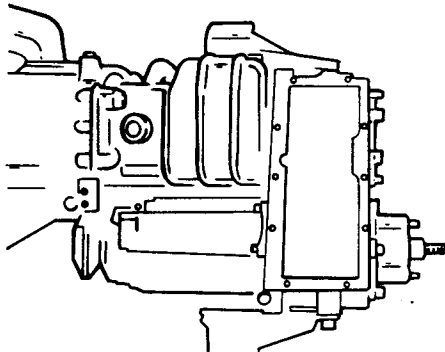

Fig H2.4

- (3) Refer to Fig H2.4. Position the gearbox assembly vertically with the clutch housing downwards. To maintain the assembly in this position, make use of the flywheel housing.
- (4) Remove the screw and nut that holds the selector lever for high and low speeds and extract the lever.

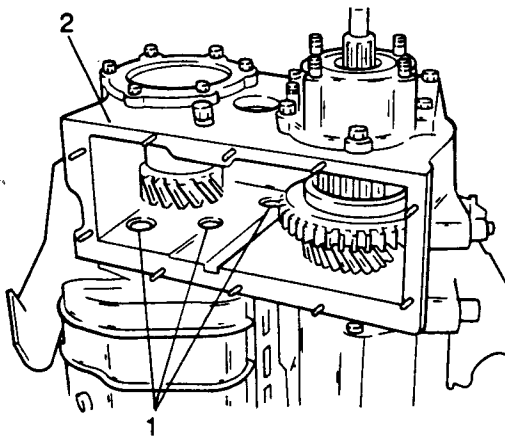

Fig H2.5

- (5) Refer to Fig H2.5. Remove the fixings bolts/nuts (1) that hold the gearbox to the transfer box.
- (6) Separate the transfer box (2) from the gearbox.

REPLACEMENT

2. Replace the transfer box as follows:
 - (1) Examine the joint washer and clean off any sealing compound that could exist on the mating surfaces of the casings.
 - (2) Apply a film of Hermetical 600 on both faces of the washer and position it on the casing.
 - (3) Fit the transfer box assembly and tighten up the nuts to a torque of 20 to 30 N.m.

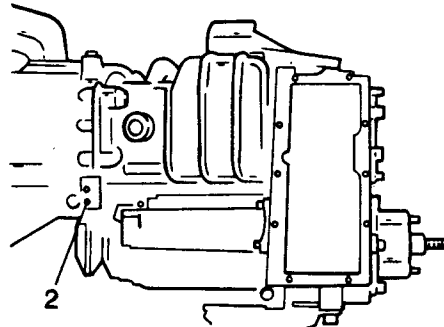

Fig H2.6

- (4) Refer to Fig H2.6. Replace the selector lever (2) for high and low speeds and secure with the screw and nut.
- (5) Replace the double intermediate gear (see Sub-sub-section H2.3, Chapter 3).
- (6) Refit the gearbox to the vehicle (see Sub-sub-section H1.3, Chapter 1).

SUB-SUB-SECTION H2.3

CHAPTER 3

DOUBLE INTERMEDIATE GEAR - REMOVAL AND REPLACEMENT

REMOVAL

1. To remove the gear:

- (1) Remove the transmission brake (see Sub-sub-section K2.4, Chapter 2).

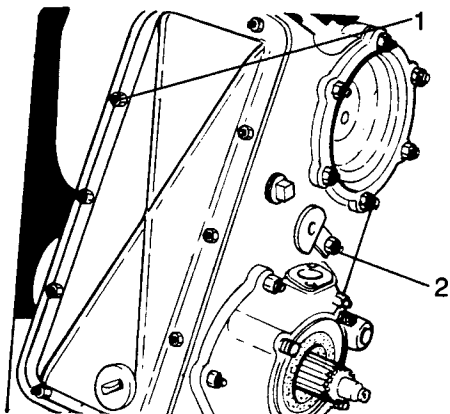

Fig H2.7

- (2) Refer to Fig H2.7. Remove the fixings (1) from the transfer box cover, together with its joint washer.
- (3) Remove the retaining nut, washer and lock washer (2) from the shaft.

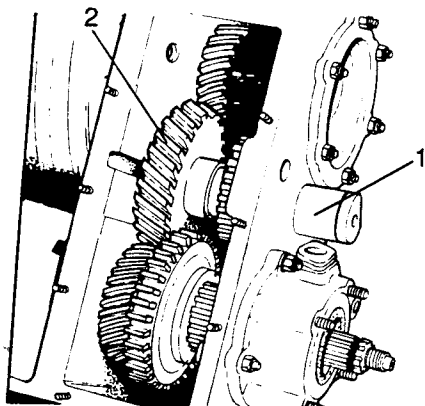

Fig H2.8

- (4) Refer to Fig H2.8. Remove the double intermediate gear shaft (1) using special tool 262772.
- (5) Remove the gear (2) together with its roller bearings and thrust washers.

INSPECTION

2. Inspect the components as follows:

- (1) Change all components that show signs of wear.

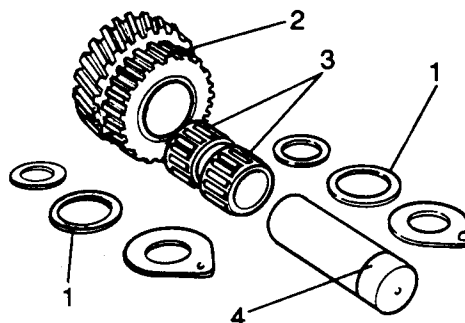

Fig H2.9

- (2) Refer to Fig H2.9. It is fundamental that the copper thrust washers (1) are not worn and if they are they must be changed.
- (3) Inspect the teeth of the gears (2).
- (4) Inspect the roller bearings (3) making sure that the fibre cages are not damaged or worn. Replace if necessary.
- (5) Inspect and change, if necessary, the shaft sealing ring (4).

REPLACEMENT

3. To replace the double intermediate gear:

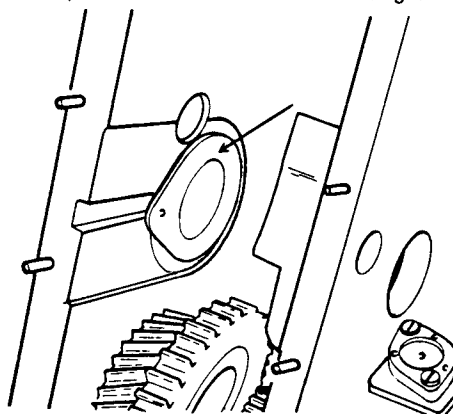

Fig H2.10

- (1) Refer to Fig H2.10. First fit the thrust washer on the casing which is fitted with dowels.

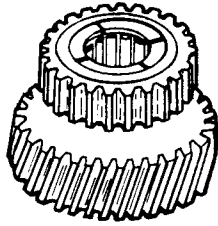

Fig H2.11

- (2) Refer to Fig H2.11. Form an assembly with the gear, bearings and thrust washers, taking into account that these have oil grooves which must face outwards. All these parts are held together by grease.

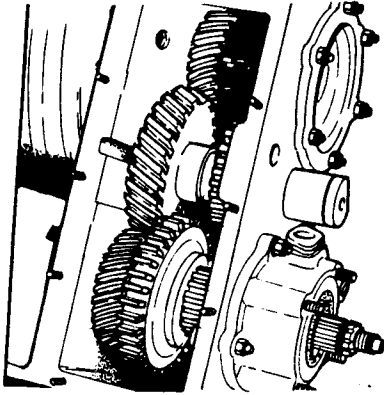

Fig H2.12

- (3) Refer to Fig H2.12. Fit the gear, bearings and washer assembly, centring them perfectly with the shaft hole and push the latter in with the hand until it reaches the shaft seal. Continue pushing the shaft home with the aid of a plastic mallet.

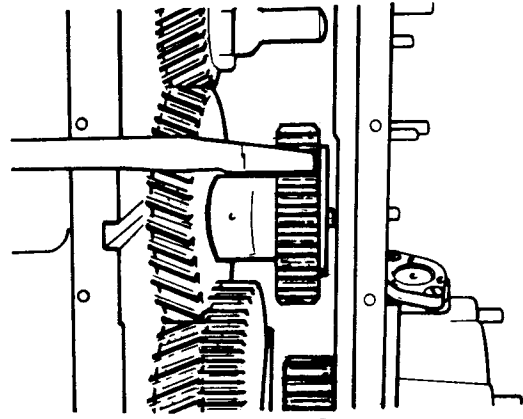

Fig H2.13

- (4) Refer to Fig H2.13. Check the end play of the intermediate double gear, which should be between 0,10 to 0,20 mm. The adjustment is carried out by sand papering the thrust washers or adding shims as necessary.

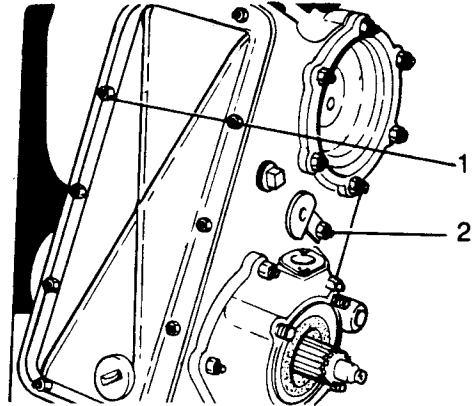

Fig H2.14

- (5) Refer to Fig H2.14. Replace the lock washer, washer and retaining nut (2) on the shaft.
- (6) Replace the joint washer cover, and the fixings (1).
- (7) Replace the transmission brake (see Sub-sub-section K2.4, Chapter 2).

SUB-SUB-SECTION H2.4

TRANSFER BOX - OVERHAUL

REMOVAL AND DISMANTLING

1. First, follow the procedure detailed below:
 - (1) Remove the transfer box from the vehicle (see Sub-sub-section H2.3, Chapter 1).
 - (2) Remove the front output shaft cover (see Sub-sub-section H1.4, Chapter 3).
 - (3) Remove the speedometer drive assembly (see Sub-sub-section H1.3, Chapter 2).
2. Strip the transfer box as follows:

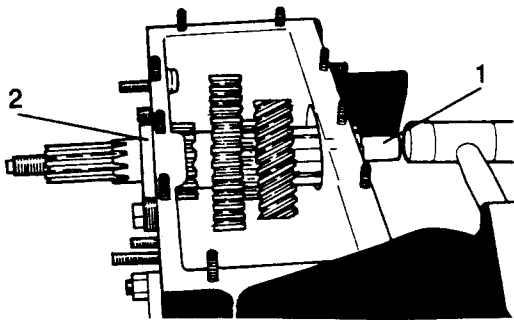

Fig H2.15

- (1) Refer to Fig H2.15. Use a plastic hammer to knock the output shaft (1) backwards.
- (2) Extract the rear bearing outer track (2) when it moves out of its housing in the casing.

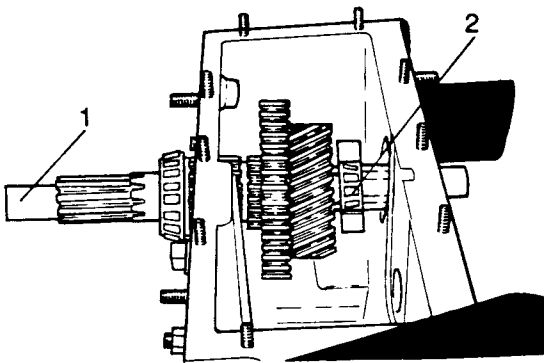

Fig H2.16

- (3) Refer to Fig H2.16. Fit special tool 243241 (1) over the threaded portion of the output shaft.
- (4) Slide the shaft backwards and between the outer track and the front bearing a second outer track (2) (used one) must be fitted, which has been cut away so that through this the shaft can pass, and slide easily into its housing.

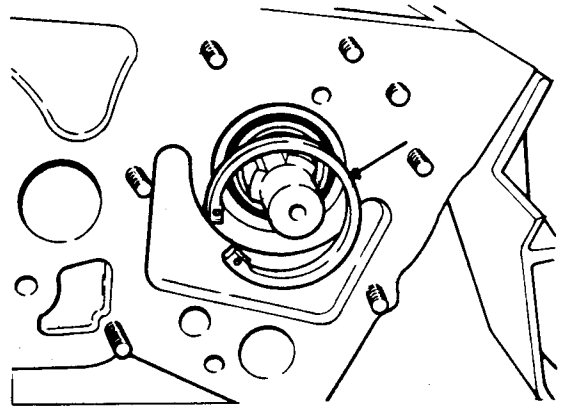

Fig H2.17

- (5) Refer to Fig H2.17. Remove the spring clip that retains the front bearing.

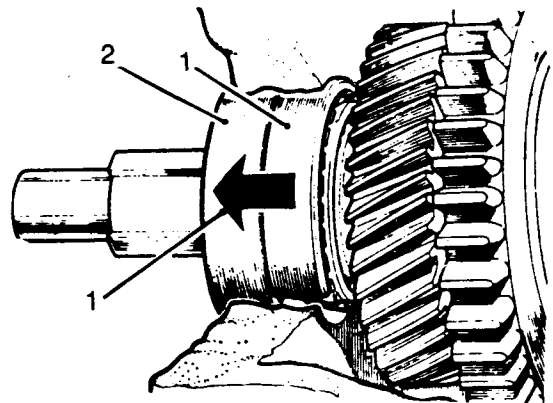

Fig H2.18

- (6) Refer to Fig H2.18. With the slave bearing (1) fitted in position, knock the output shaft forward.
- (7) Remove the front bearing outer track (2).
- (8) Once the front bearing outer track has been removed, remove the slave outer track which was used as an extractor.

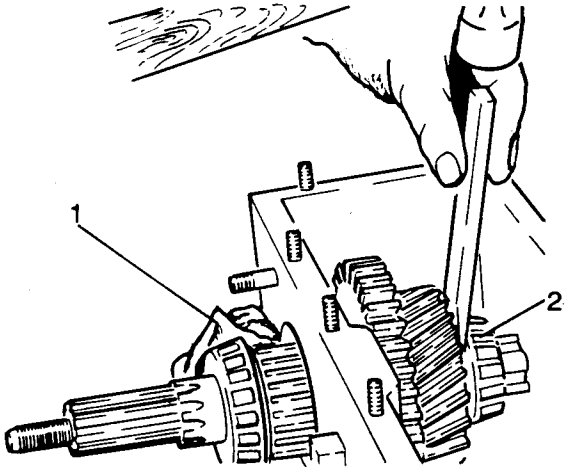

Fig H2.19

(9) Refer to Fig H2.19. Fit rags (1) in position so as to protect the bearing housing during the following operation.

(10) Use a mild steel chisel to remove the output shaft front bearing (2).

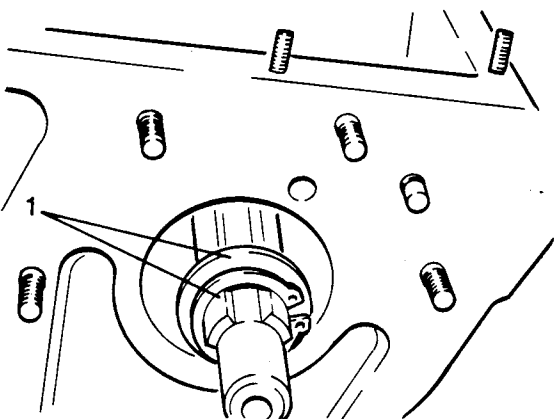

Fig H2.20

(11) Refer to Fig H2.20. Once the bearing has been removed, take off the circlip and thrust washers (1) for the output shaft gears.

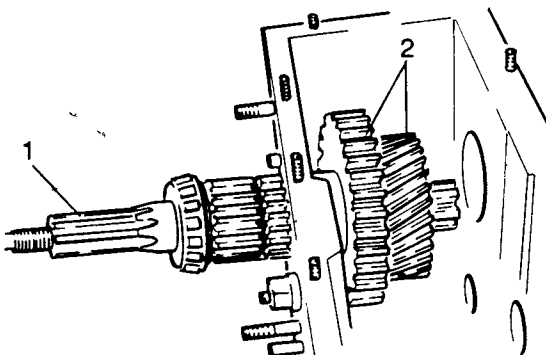

Fig H2.21

(12) Refer to Fig H2.21. Remove the output shaft (1) by sliding it backwards and the gears (2) forward into the casing.

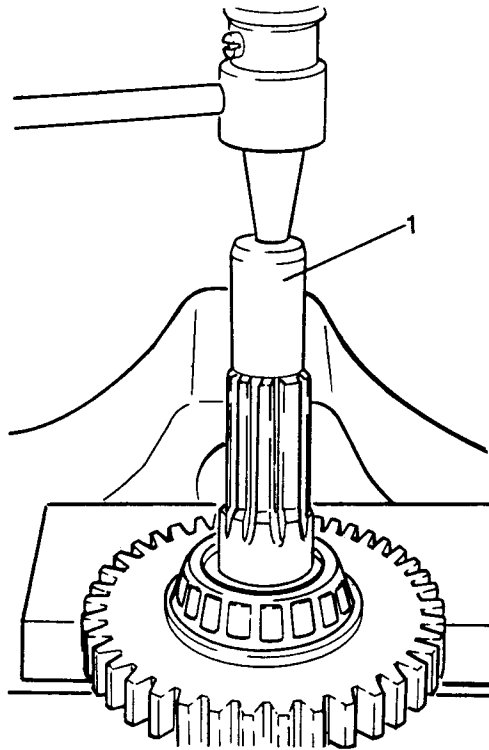

Fig H2.22

(13) Refer to Fig H2.22. Remove the rear bearing by means of a press and employing the low gear as a retaining block for the bearing (as shown).

(14) For this operation the special tool 243241 (1) must be used to protect the thread.

INSPECTION AND CHECK

3. Carry out the following inspection:

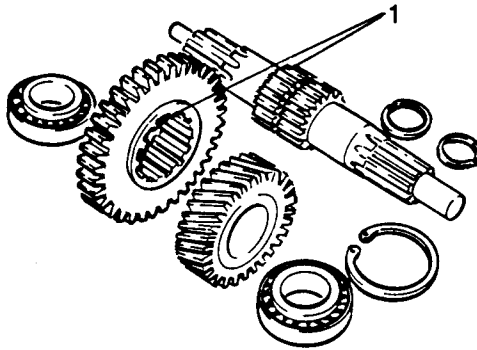

Fig H2.23

(1) Refer to Fig H2.23. Change all components that are worn or damaged. It is of utmost importance that the angles of the low gear splines (1) are not worn.

NOTE

It will be observed that the low gear fits easily over the shaft which permits the shaft to lock when in operation. This makes the output shaft spline edges mesh with the spline edges of the low gear, working in such a way that it is impossible when in low speeds to jump out of gear.

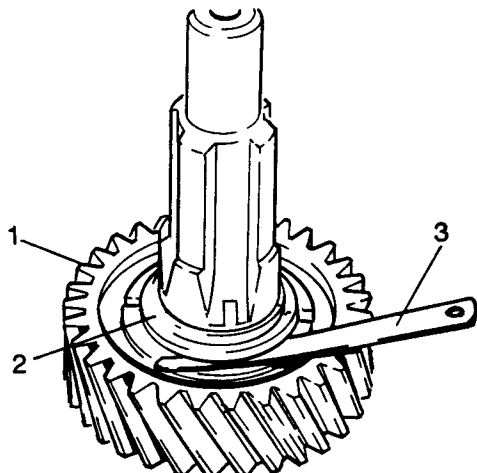

Fig H2.24

- (2) Refer to Fig H2.24. Fit the high gear (1) on the output shaft.
- (3) Fit the thrust washer and circlip (2).
- (4) Position an adequate length of tube over the shaft and push the circlip towards the gear, so as to eliminate any play of this circlip in its groove.
- (5) Maintain pressure on the circlip, measure the end float of high gear which should be between 0,10 and 0,20 mm (3).
- (6) The end float is adjusted by reducing the thickness of the thrust washer or fitting of a new washer. If the fitting of a new thrust washer does not reduce the end float to the desired limits change the gear and /or shaft.

REASSEMBLY

4. Reassemble the transfer box:

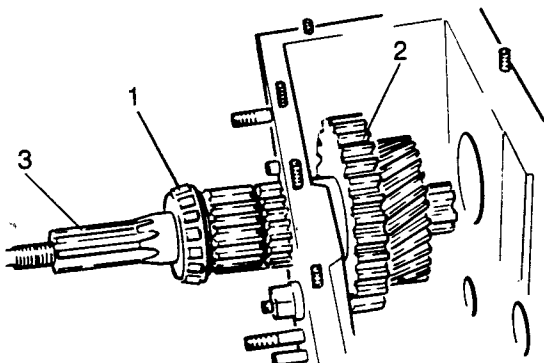

Fig H2.25

- (1) Refer to Fig H2.25. Fit the conical roller bearing (1) to the rear of the shaft.
- (2) Position the high and low gears (2).
- (3) Introduce the shaft (3) through the rear of the casing and fit the high and low gears at the same time.

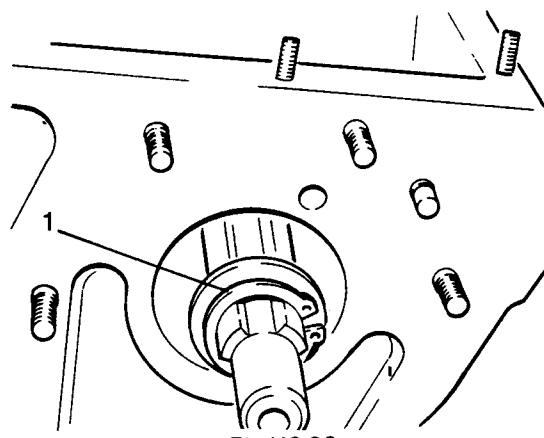

Fig H2.26

- (4) Refer to Fig H2.26. Fit the thrust washer and circlip (1).

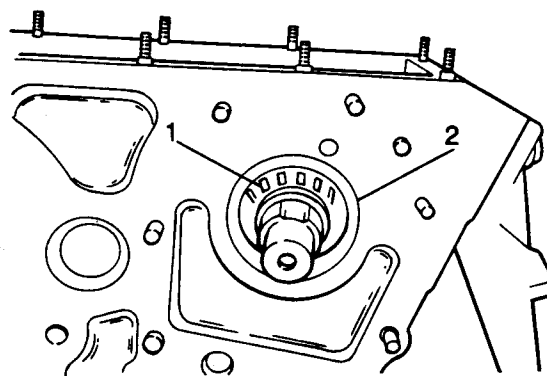

Fig H2.27

- (5) Refer to Fig H2.27. Fit the conical roller bearing (1) to the front of the shaft.
- (6) Install the front bearing outer track (2) and retain it with the circlip.

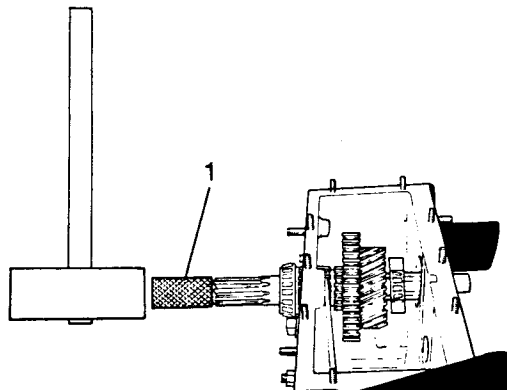

Fig H2.28

- (7) Refer to Fig H2.28. Using special tool 243241 (1) knock the shaft forward, until the front bearing remains perfectly seated between the outer track and the circlip which retains gears.
- (8) Fit the rear bearing outer track, pushing it home until there is no end float of the shaft, but maintaining the rotation of it without any preload.

5. Adjust preload of the output shaft bearing:

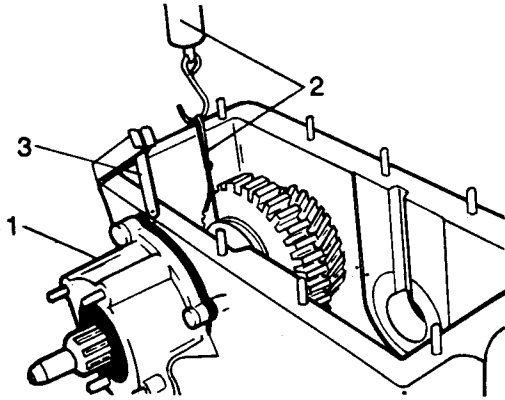

Fig H2.29

- (1) Refer to Fig H2.29. Fit the speedometer drive housing (1) without any shims and tighten the nuts with the fingers.
- (2) Measure the rolling resistance by means of a string tied around the groove of the selector gear for high and low speeds, and a spring balance. The string must not slip which would give a false reading (2).
- (3) The correct preload of the bearings is when a reading of 0,90 to 1,80 kg is achieved on the spring balance. The preload is increased by tightening the speedometer drive housing nuts uniformly.
- (4) When the preload is correct, measure the distance with feeler gauges between the speedometer drive housing and the transfer box surfaces (3). The distance is the same as the thickness of the shims to be fitted between the speedometer drive housing and transfer box.

(5) Remove the spring balance, string and speedometer drive housing.

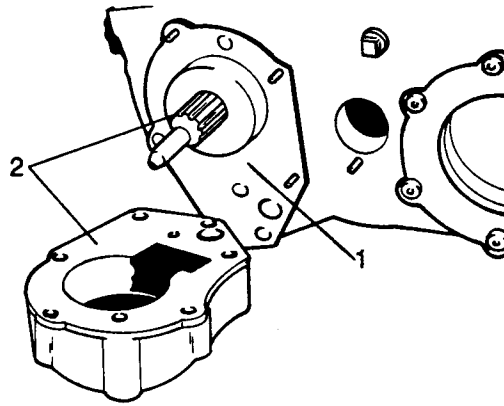

Fig H2.30

- (6) Refer to Fig H2.30, Fit the shims (1) calculated in steps (3) and (4) above.
- (7) Fit the speedometer drive worm and speedometer drive casing (2) retaining them with the nuts and lock washers. Tighten the nuts to a torque of 13 to 18 N.m.
- (8) Replace the front output shaft cover (see Sub-sub-section H1.4, Chapter 3).
- (9) Refit the transfer box to the vehicle (see Sub-sub-section H2.3, Chapter 1).

SUB-SUB-SECTION H2.5

MAINTENANCE

INTRODUCTION

1. The transfer box is designed for maintenance free operation, requiring only periodic inspections for obvious defects and checking the oil level. At intervals specified, the oil should be drained and replenished with fresh, clean oil of the correct grade.
2. At frequent intervals, depending on operating conditions, the exterior of the transfer box should be cleaned to prevent the accumulation of dirt, mud and oil, etc.

OIL CHECKING AND CHANGING

Checking Oil Level

NOTES

1. The transfer box and front wheel drive housing are lubricated as one unit.
2. The vehicle must be parked on a completely level surface before checking or changing the oil.
3. To check the oil level:

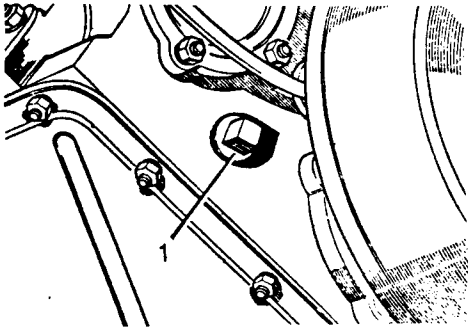

Fig H2.31

- (1) Refer to Fig H2.31. Remove the filler level plug (1) on the rear face of the transfer box.
- (2) Check that the oil level is up to the bottom of the filler plug hole.
- (3) If necessary, pour oil into the filler plug hole to bring the oil up to this level.
- (4) Allow excess oil to drain through the filler hole.
- (5) Replace and tighten the filler hole plug using a new gasket.
- (6) Wipe off excess oil around the filler plug.

NOTE

If significant topping up is required check for oil leaks at the drain and filler plugs, all joint faces and through the drain hole in the bell housing.

Changing the Oil

NOTE

Before changing the oil, the vehicle shall have been driven sufficiently to warm up the oil in the transfer box and front wheel drive housing.

4. To change the oil:
 - (1) Place a container under the transfer box of sufficient capacity to hold 2,5 litre of old oil.
 - (2) Remove the transfer box filler plug ((1) on Fig H2.31).

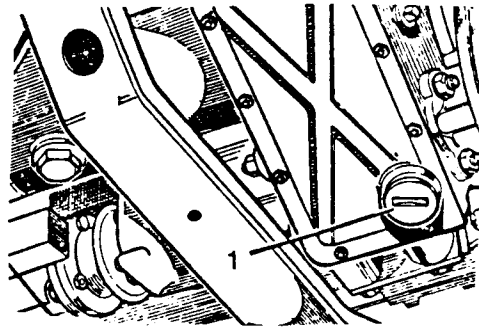

Fig H2.32

- (3) Refer to Fig H2.32. Remove the transfer box drain plug (1) and allow the oil to drain into the container.
- (4) Replace and tighten the drain plug using a new gasket.
- (5) Fill the transfer box with oil through the filler hole until the oil level is up to the bottom of the filler hole.
- (6) Allow excess oil to drain from the filler hole.
- (7) Replace and tighten the filler hole plug.
- (8) Wipe off excess oil from around the plugs.

SUB-SECTION CONTENTS LIST

SUB-SECTION H3

CLUTCH SYSTEM

| SUB-SUB-SECTION | DESCRIPTION | PAGE |
|-----------------|--|-------|
| H3.1 | DESCRIPTION AND SPECIFICATIONS | H3.3 |
| H3.2 | FAULT DIAGNOSIS AND CORRECTIVE ACTION | H3.7 |
| H3.3 | ADJUSTING THE CLUTCH PEDAL AND MASTER CYLINDER | H3.9 |
| H3.4 | REMOVAL AND REPLACEMENT PROCEDURES | H3.11 |
| H3.5 | OVERHAUL PROCEDURES | H3.19 |
| H3.6 | MAINTENANCE | H3.25 |

SUB-SUB-SECTION CONTENTS LIST

SUB-SUB-SECTION H3.1

| CHAPTER | DESCRIPTION | PAGE |
|---------|----------------------------------|------|
| 1 | DESCRIPTION OF THE CLUTCH SYSTEM | H3.5 |
| 2 | CLUJCH SPECIFICATIONS | H3.6 |

SUB-SUB-SECTION H3.1

CHAPTER 1

DESCRIPTION OF THE CLUTCH SYSTEM

GENERAL

1. The clutch is of the single dry-plate, diaphragm spring type. It is hydraulically operated from the clutch pedal through a master cylinder and a slave cylinder. The clutch is fitted between the flywheel and the gearbox, its housing being bolted to the flywheel.
2. The clutch and flywheel are covered by a bell housing to which the slave cylinder is attached. The slave cylinder push rod operates the clutch release lever inside the bell housing.
3. The master cylinder is attached to the rear wall of the engine compartment and incorporates a clutch fluid reservoir with a screw cap. The cylinder push rod is connected directly to the clutch pedal in the driver's cab.

OPERATION

4. Pushing the clutch pedal down pushes a piston in the master cylinder forwards and forces hydraulic fluid to flow through the pipe connecting the master to the slave cylinder. The fluid flow pushes the slave cylinder piston forwards and the rod attached to the piston moves the clutch release lever on its fulcrum to move clutch driven plate away from the flywheel. In this manner the engine is disconnected from the gearbox until the clutch pedal is released. When this occurs the flow of fluid between the master and slave cylinders is reversed and the clutch driven plate again contacts the flywheel to provide a drive to the gearbox.

SUB-SUB-SECTION H3.1

CHAPTER 2

CLUTCH SPECIFICATIONS

INTRODUCTION

1. The specifications for the clutch system are given in the following Tables:

TABLE H3.1 - GENERAL DATA

TABLE H3.2 - TORQUE SPECIFICATIONS

TABLE H3.1 - GENERAL DATA

| ITEM | DESCRIPTION |
|--|--------------------------------|
| Make and type | Girlock S.A., diaphragm spring |
| Driven plate diameter | 241,3 mm |
| Master cylinder diameter | 15,875 mm |
| Master cylinder push rod free play | 1,5 mm |
| Slave cylinder diameter | 22,225 mm |
| Thrust bearing type | RHP, ball bearing |
| Clutch pedal pivot bushes, reamed diameter | 15,87 ± 0,02 mm |
| Clutch pedal height setting | 140 mm |
| Clutch pedal free play (minimum) | 6 mm |

TABLE H3.2 - TORQUE SPECIFICATIONS

| ITEM | TORQUE (N.m) |
|--------------------|--------------|
| Clutch cover bolts | 30 to 35 |

SUB-SUB-SECTION H3.2

FAULT DIAGNOSIS AND CORRECTIVE ACTION

INTRODUCTION

1. This sub-section deals with fault diagnosis and corrective action on the clutch system. In Table H3.3 a list of symptoms, the probable causes and the necessary remedies are set out. If a fault is suspected, the list of symptoms should be consulted. It should be noted that the Table is not exhaustive and faults may occur which are not listed. Should the Table fail to reveal the fault, the suspected component/s should be removed for closer inspection and/or overhaul.

2. The clutch assembly is of the diaphragm spring type and no overhaul procedures are applicable. Repair is by replacement only.

TABLE H3.3 - CLUTCH FAULT DIAGNOSIS CHART

| SYMPTOM | POSSIBLE CAUSE | REMEDY |
|-------------------------------------|--|--|
| Gear grating and difficult shifting | Lack of clutch pedal reserve total travel. Air in clutch hydraulic system. Lost motion in clutch release fork at pivot point. Cracked release fork. Leaking master or slave cylinder. Excessive idle speed. Clutch binding on input shaft. Excessive clutch plate runout. Oil or grease on clutch lining. Loose linings on clutch plate. Clutch housing or gearbox misaligned. | Check clutch mechanism adjustment. Bleed system. Replace damaged or worn parts. Replace defective part. Repair or replace defective parts. Adjust engine idle rev/min. Check for burrs on splines of clutch and input shaft, remove burrs or replace defective parts. Replace clutch plate. Replace clutch plate and check for leaks on engine, gearbox or release bearing. Replace clutch plate. Check alignment of clutch housing and gearbox. |
| Clutch slipping | Incorrect adjustment of clutch release mechanism. Worn clutch lining. Damaged or contaminated clutch lining (oil, grease). | Check clutch mechanism adjustment. Replace clutch plate. Replace clutch plate. |
| Clutch judder | Damaged or contaminated clutch lining. Clutch housing or gearbox misaligned. Driven plate not parallel to flywheel face. Loose, broken or worn engine mountings. | Replace clutch plate. Check alignment of clutch housing and gearbox. Replace driven plate. Tighten or replace engine mountings. |
| Clutch rattle | Damaged clutch plate. Worn splines. Worn gearbox bearings. Excessive backlash in gearbox. | Replace clutch plate. Replace defective parts. Overhaul gearbox. Overhaul gearbox. |
| Fractured clutch | Clutch housing or gearbox misaligned. Clutch centre bent during assembly. | Check alignment of clutch housing and gearbox. Fit new clutch plate taking care during assembly. |

TABLE H3.3 - CLUTCH FAULT DIAGNOSIS CHART - CONTINUED

| SYMPTOM | POSSIBLE CAUSE | REMEDY |
|----------------------|---|---|
| Abnormal clutch wear | Overloading vehicle (slipping clutch during pull-off). Too high a gear ratio used when pulling off. Pedal mechanism incorrectly adjusted. | Do not overload vehicle. Educate driver. Check pedal free play and travel. |
| Clutch grabbing | Dry or rusted spigot shaft spline. Rusted flywheel. | Clean and lubricate with dry graphite based lubricant. Release clutch very slowly until grabbing stops, if it persists, the rust is severe and cleaning after removal of the gearbox and driven plate will be necessary. |

SUB-SUB-SECTION H3.3

ADJUSTING THE CLUTCH PEDAL AND MASTER CYLINDER

1. The following is the procedure for setting the clutch pedal height and free play and the free play in the master cylinder push rod:

(1) Remove the bonnet (see Sub-section M3, Chapter 1).

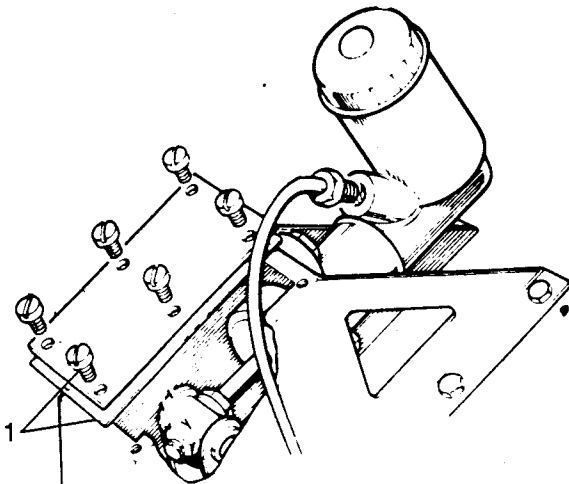

Fig H3.1

(2) Refer to Fig H3.1. Remove the top cover (1) and gasket from the clutch pedal bracket.

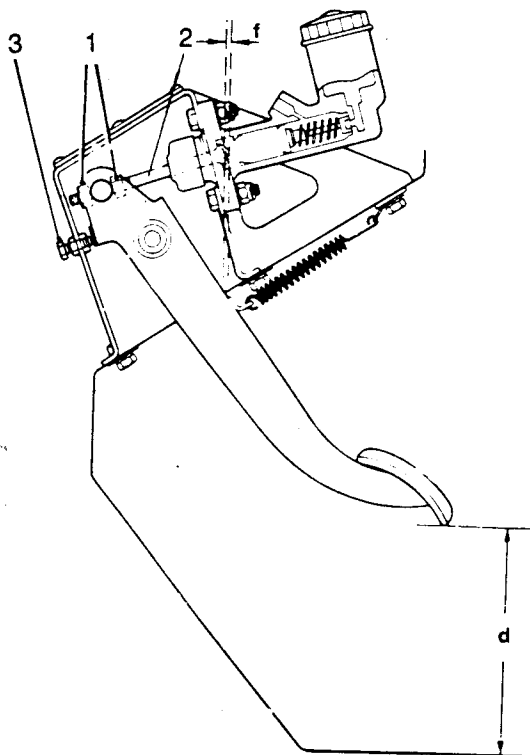

Fig H3.2

(3) Refer to Fig H3.2. Slacken both lock nuts (1) on the master cylinder push rod (2).

(4) Check the distance from the lower edge of the clutch pedal to the floor (distance 'd' in Fig H3.2). The correct distance is 140 mm.

(5) Adjust the pedal stop (3) if necessary to obtain the correct distance.

(6) Adjust the position of the master cylinder push rod (2) until there is approximately 1,5 mm free play between the push rod and the master cylinder piston (distance 'f' on Fig H3.2).

(7) Tighten both lock nuts (1).

(8) Check the clutch pedal for a minimum of 6 mm free movement of the pedal before pressure is felt. Readjust the master cylinder push rod if necessary.

(9) Replace the top cover and gasket. Use a silicon rubber adhesive to retain the gasket if necessary.

(10) Replace the bonnet.

SUB-SUB-SECTION CONTENTS LIST

SUB-SUB-SECTION H3.4

REMOVAL AND REPLACEMENT PROCEDURES

| CHAPTER | DESCRIPTION | PAGE |
|---------|---|-------|
| 1 | CLUTCH ASSEMBLY - REMOVAL AND REPLACEMENT | H3.13 |
| 2 | MASTER CYLINDER - REMOVAL AND REPLACEMENT | H3.14 |
| 3 | SLAVE CYLINDER - REMOVAL AND REPLACEMENT | H3.15 |
| 4 | CLUTCH RELEASE ASSEMBLY - REMOVAL AND REPLACEMENT | H3.16 |
| 5 | CLUTCH PEDAL - REMOVAL AND REPLACEMENT | H3.17 |

SUB-SUB-SECTION H3.4

CHAPTER 1

CLUTCH ASSEMBLY - REMOVAL AND REPLACEMENT

REMOVAL

1. To remove the clutch assembly:
 - (1) Remove the gearbox assembly (see Sub-sub-section H1.3, Chapter 1).

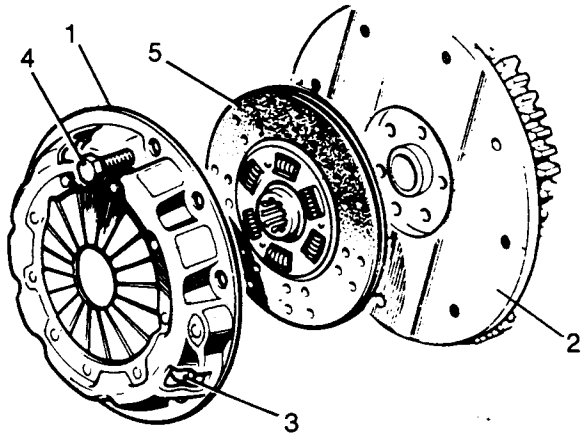
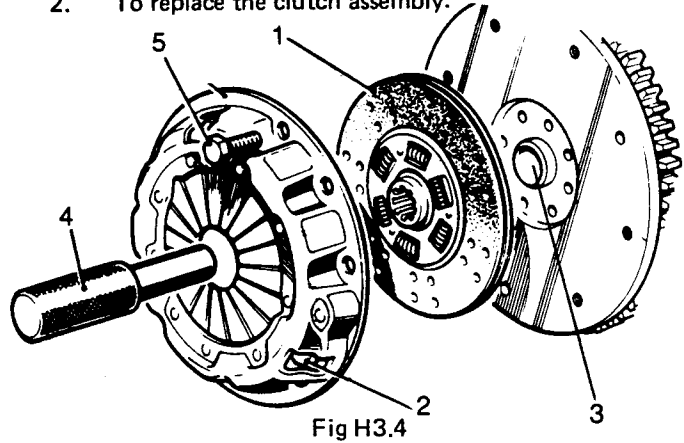

Fig H3.3

- (2) Refer to Fig H3.3. Mark the clutch cover (1) fitted position relative to the flywheel (2).
- (3) Do not disturb the three bolts in the apertures (3) in the clutch cover.
- (4) Remove the bolts (4) holding the clutch cover to the flywheel and remove the cover.
- (5) Withdraw the clutch driven plate (5).

REPLACEMENT

2. To replace the clutch assembly:



- (1) Refer to Fig H3.4. Position the clutch driven plate (1) with the side marked 'flywheel side' towards the flywheel.
- (2) Ensure that the marks on the cover and flywheel are aligned and offer up the cover/driven plate to the flywheel.
- (3) Line up the hole in the cover with the splined hole in the driven plate (2) and the bearing in the crankshaft (3) using special tool 18G79SA (4).
- (4) Secure the cover to the flywheel with the bolts (5) and, using diagonal selection, tighten the bolts evenly to 30 to 35 N.m.
- (5) Remove special tool 18G79SA.

SUB-SUB-SECTION H3.4

CHAPTER 2

MASTER CYLINDER - REMOVAL AND REPLACEMENT

REMOVAL

1. To remove the master cylinder:
 - (1) Remove the bonnet (see Sub-section M3, Chapter 1).

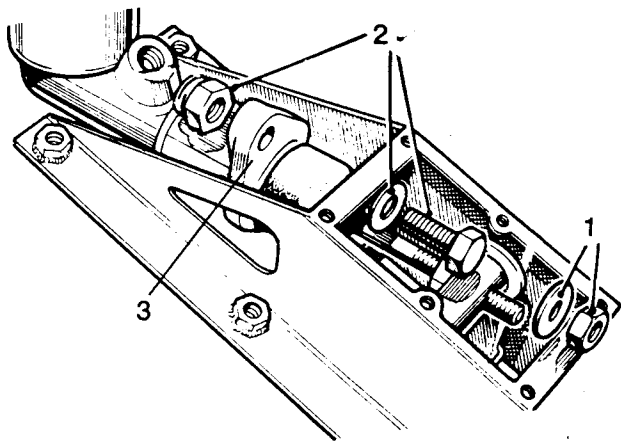

Fig H3.5

- (2) Refer to Fig H3.5. Disconnect the fluid pipe from the master cylinder.
- (3) Remove the top cover and gasket from the clutch pedal bracket.
- (4) Remove the fixing (1) from the end of the master cylinder push rod.
- (5) Remove the master cylinder fixings (2).
- (6) Remove the master cylinder (3) from the pedal bracket.

REPLACEMENT

2. Replace the master cylinder as follows:
 - (1) Fit the master cylinder to the pedal bracket, engaging the cylinder push rod through the pedal trunion (4).
 - (2) Fit the plain washer and nut to the end of the push rod.
 - (3) Connect the fluid pipe to the master cylinder.
 - (4) Bleed the hydraulic system (see Sub-sub-section H3.6).
 - (5) Adjust the pedal and master cylinder (see Sub-sub-section H3.3).

SUB-SUB-SECTION H3.4

CHAPTER 3

SLAVE CYLINDER - REMOVAL AND REPLACEMENT

REMOVAL

1. To remove the slave cylinder:

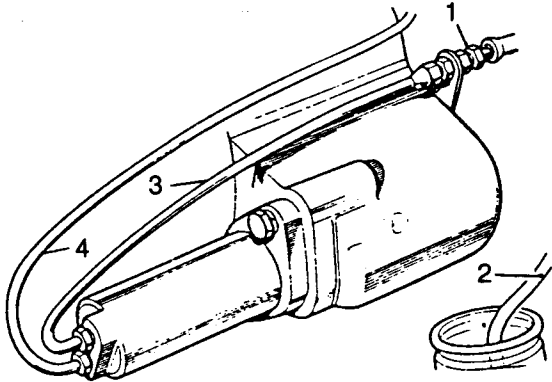

Fig H3.6

- (1) Refer to Fig H3.6. Slacken the bleed screw (1) and drain the hydraulic fluid into a suitable container using a bleed tube (2).
- (2) Disconnect the bleed pipe (3).
- (3) Disconnect the fluid pipe (4).

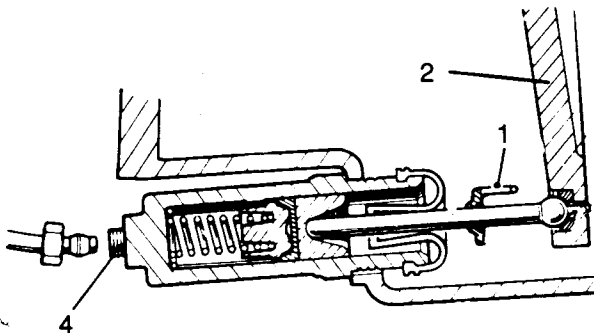

Fig H3.7

- (4) Refer to Fig H3.7. Release the plastic clip (1) from the clutch release lever (2) and slide the clip along the push rod (3).

- (5) Remove the two retaining bolts and pull the slave cylinder away.

REPLACEMENT

2. Replace the slave cylinder as detailed below:

- (1) Partially extend the push rod by applying low pressure air to the fluid connector (4).
- (2) Position the push rod central to the body.
- (3) Locate the push rod end into the seating in the release lever (2) and retain with the plastic clip (1).
- (4) Fit the slave cylinder, bleed valve uppermost and secure with the two bolts and washers.
- (5) Fit the fluid pipe (4).
- (6) Fit the bleed pipe.
- (7) Bleed the system (see Sub-sub-section H3.6).

SUB-SUB-SECTION H3.4

CHAPTER 4

CLUTCH RELEASE ASSEMBLY - REMOVAL AND REPLACEMENT

REMOVAL

1. To remove the clutch release assembly:
 - (1) Remove the gearbox assembly (see Sub-sub-section H1.3, Chapter 1).

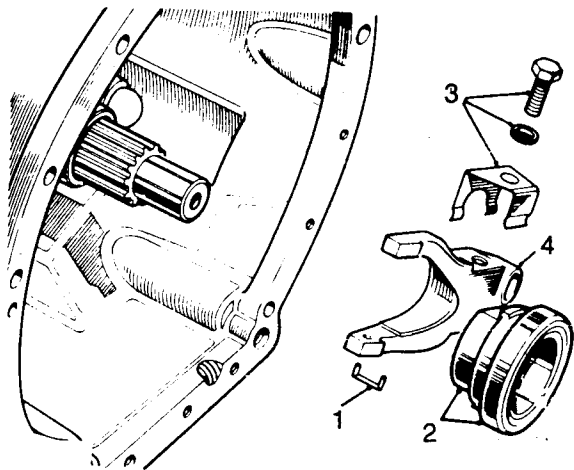

Fig H3.8

- (2) Refer to Fig H3.8. Withdraw the retainer staple (1).
- (3) Withdraw the bearing and sleeve (2). If required, press the bearing off the sleeve.
- (4) Remove the spring clip (3) and fixings.
- (5) Withdraw the release lever (4).

REPLACEMENT

2. Replace the clutch release assembly as follows:
 - (1) Fit the release lever (4).
 - (2) Replace the spring clip and fixings (3).
 - (3) If required, fit a replacement bearing onto the sleeve (2) with the domed face outwards from the sleeve.
 - (4) Lubricate the bearing sleeve inner diameter with PBC (Poly Butyl Caprysil) grease.
 - (5) Refit the bearing and retainer staple (1).
 - (6) Replace the gearbox (see Sub-sub-section H1.3, Chapter 1).