

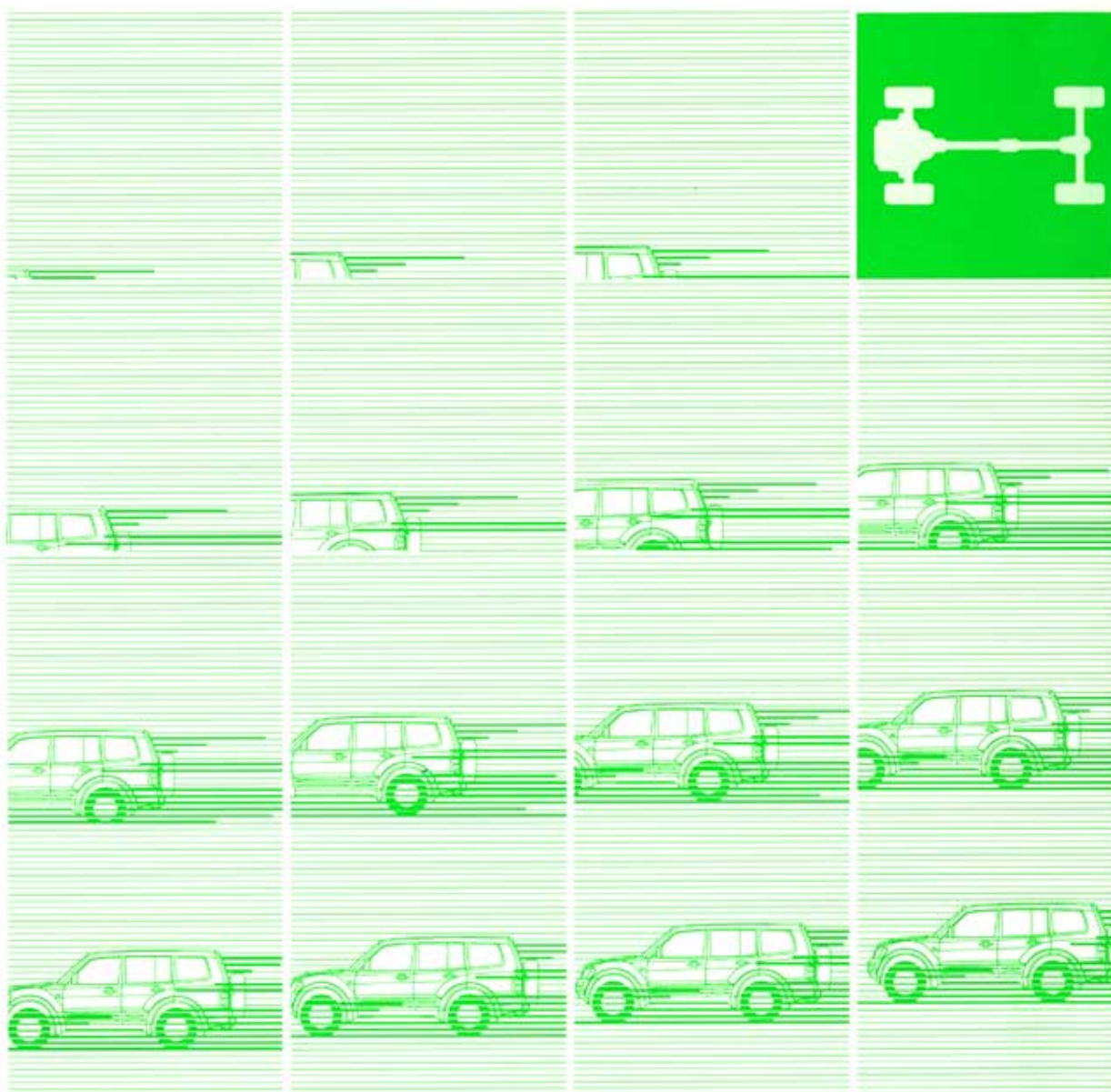

Workshop Manual

chassis

PAJERO



PAJERO

WORKSHOP MANUAL

FOREWORD

This Workshop Manual contains procedures for service mechanics, including removal, disassembly, inspection, adjustment, reassembly and installation. Use the following manuals in combination with this manual as required.

TECHNICAL INFORMATION MANUAL	PYJE0001
WORKSHOP MANUAL	
ENGINE GROUP	PWEE _____ (Looseleaf edition)
CHASSIS GROUP	PWJE0001
ELECTRICAL WIRING	PHJE0001
BODY REPAIR MANUAL	PBJE0001
PARTS CATALOGUE	B603H601A□

All information, illustrations and product descriptions contained in this manual are current as at the time of publication. We, however, reserve the right to make changes at any time without prior notice or obligation.

General	00
Engine	11
Engine Lubrication	12
Fuel	13
Engine Cooling	14
Intake and Exhaust	15
Engine Electrical	16
Engine and Emission Control	17
Clutch	21
Manual Transmission	22
Automatic Transmission	23
Propeller Shaft	25
Front Axle	26
Rear Axle	27
Wheel and Tyre	31
Power Plant Mount	32
Front Suspension	33
Rear Suspension	34
Service Brakes	35
Parking Brakes	36
Steering	37
Body	42
Exterior	51
Interior and Supplemental Restraint System (SRS)	52
Chassis Electrical	54
Heater, Air Conditioner and Ventilation	55



"GDI" is a trade mark of Mitsubishi Motors Corporation.

WARNING!

- (1) Improper service or maintenance of any component of the SRS and any SRS-related component, can lead to personal injury or death to service personnel (from inadvertent firing of the air bag or to the driver and passenger (from rendering the SRS inoperative).**
- (2) SRS components should not be subjected to heat, so remove the SRS-ECU, air bag module (driver's side and front passenger's side), clock spring, side impact sensor and front seat assembly (side air bag module) before drying or baking the vehicle after painting.
SRS-ECU, air bag module, clock spring and side impact sensor: 93°C or more**
- (3) Service or maintenance of any SRS component and SRS-related component must be performed only at an authorized MITSUBISHI dealer.**
- (4) MITSUBISHI dealer personnel must thoroughly review this manual, and especially its GROUP 52B - Supplemental Restraint System (SRS), before beginning any service or maintenance of any component of the SRS and any SRS-related component.**

NOTE

Section titles with asterisks (*) in the table of contents in each group indicate operations requiring warnings.

ENGINE

CONTENTS

ENGINE <6G7>	11A
ENGINE <4D5>	11B
ENGINE <4M4>	11C



FUEL

CONTENTS

GASOLINE DIRECT INJECTION (GDI)	13A
DIESEL FUEL <4D5>	13B
DIESEL FUEL <4M4>	13C
FUEL SUPPLY	13D

SERVICE BRAKES

CONTENTS

BASIC BRAKE SYSTEM	35A
ANTI-SKID BRAKING SYSTEM (ABS) <4WD>	35B



INTERIOR AND SUPPLEMENTAL RESTRAINT SYSTEM (SRS)

CONTENTS

INTERIOR	52A
SUPPLEMENTAL RESTRAINT SYSTEM (SRS)	52B



CHASSIS ELECTRICAL

CONTENTS

CHASSIS ELECTRICAL	54A
SMART WIRING SYSTEM (SWS)	54B



HEATER, AIR CONDITIONER AND VENTILATION

CONTENTS

MANUAL A/C	55A
AUTOMATIC A/C	55B

GENERAL

Click on the applicable bookmark to selected the required model year.

GENERAL

CONTENTS

HOW TO USE THIS MANUAL	2	VEHICLE IDENTIFICATION	16
Scope of Maintenance, Repair and Servicing		Vehicle Information Code Plate	16
Explanations	2	Models	16
Definition of Terms	2	Model Code	18
Indication of Tightening Torque	2	Chassis Number	19
Model Indications	3	Engine Model Number	20
Explanation of Manual Contents	4	Theft Protection <For R.H.D.>	21
HOW TO USE TROUBLESHOOTING/INSPECTION SERVICE POINTS	6	MAJOR SPECIFICATIONS	23
Troubleshooting Contents	6	PRECAUTIONS BEFORE SERVICE	29
Diagnosis Function	7	SUPPLEMENTAL RESTRAINT SYSTEM (SRS)	33
How to Use the Inspection Procedures	10	SUPPORT LOCATIONS FOR LIFTING AND JACKING	37
Connector Measurement Service Points	11	Support Positions for a Garage Jack	37
Connector Inspection	12	Support Positions for axle stands and a Single-Post Lift or Double-Post Lift	38
Inspection Service Points for a Blown Fuse ...	13	STANDARD PARTS-TIGHTENING-TORQUE TABLE	39
Points to Note for Intermittent Malfunctions ...	13		
TREATMENT BEFORE/AFTER THE FORDING A STREAM	14		
Inspection and Service before Fording a Stream	14		
Inspection and Service after Fording a Stream	15		

HOW TO USE THIS MANUAL

SCOPE OF MAINTENANCE, REPAIR AND SERVICING EXPLANATIONS

This manual provides explanations, etc. concerning procedures for the inspection, maintenance, repair and servicing of the subject model. Note, however, that for engine and transmission-related component parts, this manual covers only on-vehicle inspections, adjustments, and the removal and installation procedures for major components.

For detailed information concerning the inspection, checking, adjustment, disassembly and reassembly of the engine, transmission and major components after they have been removed from the vehicle, please refer to separate manuals covering the engine and the transmission.

ON-VEHICLE SERVICE

“On-vehicle Service” is procedures for performing inspections and adjustments of particularly important locations with regard to the construction and for maintenance and servicing, but other inspection (for looseness, play, cracking, damage, etc.) must also be performed.

INSPECTION

Under this title are presented inspection and checking procedures to be performed by using special tools and measuring instruments and by feeling, but, for actual maintenance and servicing procedures, visual inspections should always be performed as well.

DEFINITION OF TERMS

STANDARD VALUE

Indicates the value used as the standard for judging the quality of a part or assembly on inspection or the value to which the part or assembly is corrected and adjusted. It is given by tolerance.

LIMIT

Shows the standard for judging the quality of a part or assembly on inspection and means the maximum or minimum value within which the part or assembly must be kept functionally or in strength. It is a value established outside the range of standard value.

REFERENCE VALUE

Indicates the adjustment value prior to starting the work (presented in order to facilitate assembly and adjustment procedures, and so they can be completed in a shorter time).

CAUTION

Indicates the presentation of information particularly vital to the worker during the performance of maintenance and servicing procedures in order to avoid the possibility of injury to the worker, or damage to component parts, or a reduction of component or vehicle function or performance, etc.

INDICATION OF TIGHTENING TORQUE

Tightening torques (units: N·m) are set to take into account the central value and the allowable tolerance. The central value is the target value, and the allowable tolerance provides the checking range for tightening torques. If bolts and nuts are not provided with tightening torques, refer to P.00-39.

MODEL INDICATIONS

The following abbreviations are used in this manual for classification of model types.

GDI: Indicates the gasoline direct injection.

DOHC: Indicates an engine with the double overhead camshaft, or models equipped with such an engine.

M/T: Indicates the manual transmission, or models equipped with the manual transmission.

A/T: Indicates the automatic transmission, or models equipped with the automatic transmission.

A/C: Indicates the air conditioner.

EXPLANATION OF MANUAL CONTENTS

Indicates procedures to be performed before the work in that section is started, and procedures to be performed after the work in that section is finished.

Component Diagram

A diagram of the component parts is provided near the front of each section in order to give a reader a better understanding of the installed condition of component parts.

Indicates (by symbols) where lubrication is necessary.

Maintenance and Servicing Procedures

The numbers provided within the diagram indicate the sequence for maintenance and servicing procedures.

- **Removal steps:**
The part designation number corresponds to the number in the illustration to indicate removal steps.
- **Disassembly steps:**
The part designation number corresponds to the number in the illustration to indicate disassembly steps.

- **Installation steps:**
Specified in case installation is impossible in reverse order of removal steps. Omitted if installation is possible in reverse order of removal steps.
- **Reassembly steps:**
Specified in case reassembly is impossible in reverse order of disassembly steps. Omitted if reassembly is possible in reverse order of disassembly steps.





Classifications of Major Maintenance/Service Points

When there are major points relative to maintenance and servicing procedures (such as essential maintenance and service points, maintenance and service standard values, information regarding the use of special tools, etc.), these are arranged together as major maintenance and service points and explained in detail.

- ◀A▶ : Indicates that there are essential points for removal or disassembly.
▶A◀ : Indicates that there are essential points for installation or reassembly.

Symbols for Lubrication, Sealants and Adhesives

Information concerning the locations for lubrication and for application of sealants and adhesives is provided, by using symbols, in the diagram of component parts or on the page following the component parts page, and explained.

-  : Grease
(multipurpose grease unless there is a brand or type specified)
-  : Sealant or adhesive
-  : Brake fluid or automatic transmission fluid
-  : Engine oil, gear oil or air conditioner compressor oil
-  : Adhesive tape or butyl rubber tape

Indicates the group title.

Indicates the section title.

Indicates the group number.

Indicates the page number.

STEERING – Power Steering Oil Pump 37A-29

POWER STEERING GEAR BOX

120000039

REMOVAL AND INSTALLATION

Pre-removal Operation

- (1) Power Steering Fluid Draining (Refer to P. 37A-10.)
- (2) Air Cleaner Assembly Removal
- (3) Under Cover Removal (Refer to GROUP 42 – Under Cover.)

<2WD>

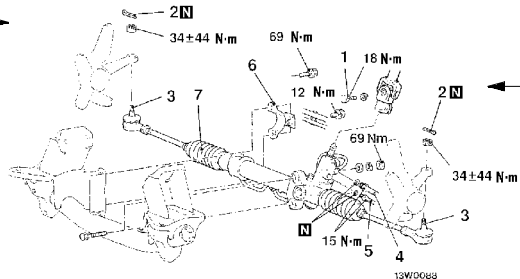

N denotes non-reusable part.

Denotes tightening torque. For bolts and nuts which do not have a tightening torque listed, refer to the "Standard Parts-tightening-torque Table".

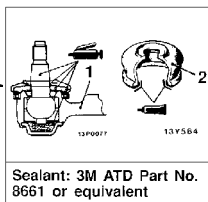

Sealant: 3M ATD Part No. 8661 or equivalent

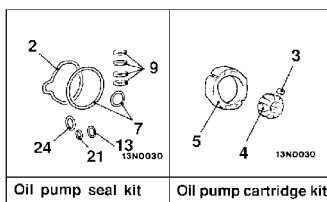

Repair kit or set parts are shown. (Only very frequently used parts are shown.)

Removal steps

1. Lower shaft assembly and gear box connecting bolt
2. Split pin
3. Connection for tie-rod end and knuckle
4. Connection for return tube

5. Connection for pressure tube
6. Clamp
7. Gear box assembly

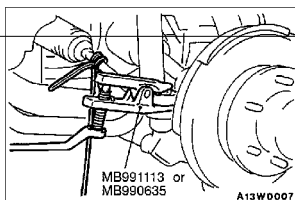

REMOVAL SERVICE POINTS

▲ TIE-ROD END DISCONNECTION

Caution

1. Using the special tool, loosen the tie rod end mounting nut. Only loosen the nut; do not remove it from the ball joint.
2. Support the special tool with a cord, etc. to prevent it from coming off.

Operating procedures, cautions, etc. on removal, installation, disassembly and reassembly are described.

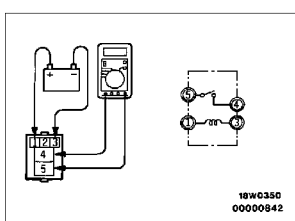

HEADLAMP RELAY CONTINUITY INSPECTION

Battery voltage	Terminal No.			
	1	3	4	5
Power is not supplied	○	○	○	○
Power is supplied	⊕	- ⊖	○	○

○—○ indicates that there is a continuity between the terminals.
 ⊕—⊖ indicates terminals to which battery voltage is applied.

35A-26 BASIC BRAKE SYSTEM – Master Cylinder and Brake Booster

Lubrication and sealing points

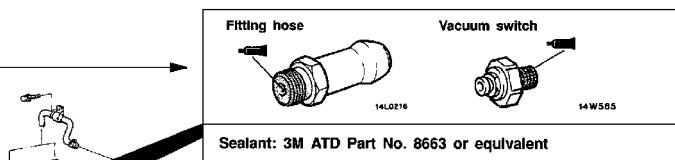

The title of the page (following the page on which the diagram of component parts is presented) indicating the locations of lubrication and sealing procedures.

HOW TO USE TROUBLESHOOTING/INSPECTION SERVICE POINTS

Troubleshooting of electronic control systems for which the MUT-II can be used follows the basic outline described below. Furthermore, even in systems for which the MUT-II cannot be used, part of these systems still follow this outline.

TROUBLESHOOTING CONTENTS

1. STANDARD FLOW OF DIAGNOSIS TROUBLESHOOTING

The troubleshooting sections follow the basic diagnosis flow which is given below. If the diagnosis flow is different from that given below, or if additional explanation is required, the details of such differences or additions will also be listed.

Diagnosis method

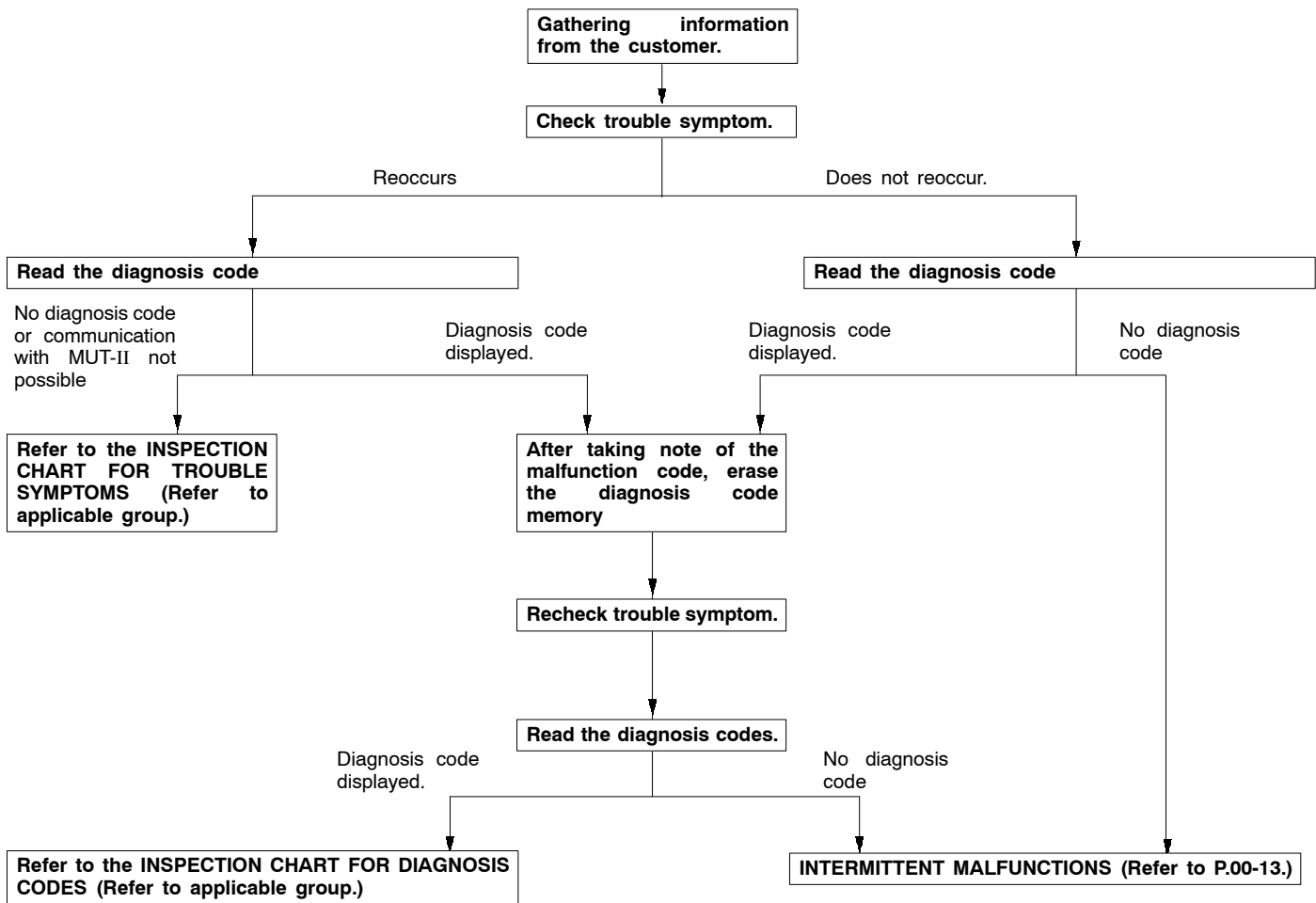

2. SYSTEM OPERATION AND SYMPTOM VERIFICATION TESTS

If verification of the trouble symptoms is difficult, procedures for checking operation and verifying trouble symptoms are shown.

3. DIAGNOSIS FUNCTION

Details which are different from those in the "Diagnosis Function" section on the next page are listed.

4. INSPECTION CHART FOR DIAGNOSIS CODES**5. INSPECTION PROCEDURE FOR DIAGNOSIS CODES**

Indicates the inspection procedures corresponding to each diagnosis code. (Refer to P.00-10 for how to use the inspection procedures.)

6. INSPECTION CHART FOR TROUBLE SYMPTOMS

If there are trouble symptoms even though the results of inspection using the MUT-II show that all diagnosis codes are normal, inspection procedures for each trouble symptom will be found by means of this chart.

7. INSPECTION PROCEDURE FOR TROUBLE SYMPTOM

Indicates the inspection procedures corresponding to each trouble symptoms classified in the Inspection Chart for Trouble Symptoms. (Refer to P.00-10 for how to use the inspection procedures.)

8. SERVICE DATA REFERENCE TABLE

Inspection items and normal judgement values have been provided in this chart as reference information.

9. CHECK AT ECU TERMINALS

Terminal numbers for the ECU connectors, inspection items and standard values have been provided in this chart as reference information.

10. INSPECTION PROCEDURES USING AN OSCILLOSCOPE

When there are inspection procedures using an oscilloscope, these are listed here.

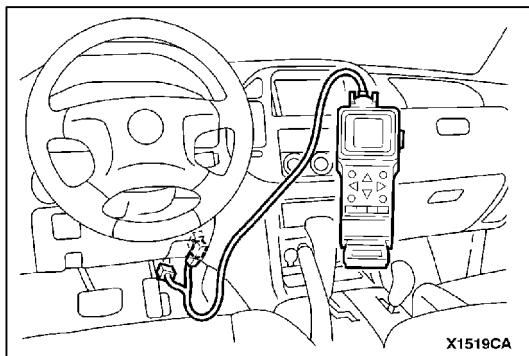
**DIAGNOSIS FUNCTION****METHOD OF READING DIAGNOSIS CODES****WHEN USING THE MUT-II**

Connect the MUT-II to the diagnosis connector and take a reading of the diagnosis codes.

Caution

Turn the ignition switch to “LOCK(OFF)” position before connecting or disconnecting the MUT-II.

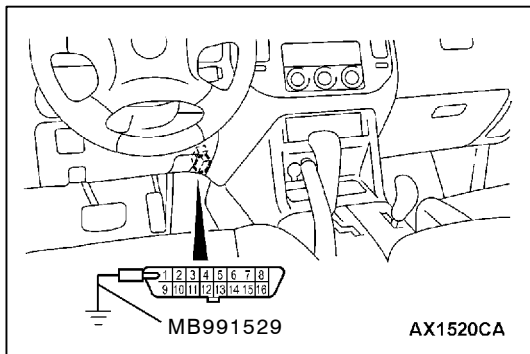

WHEN USING THE WARNING LAMP

1. Use the special tool to earth No.1 terminal (diagnosis control terminal) of the diagnosis connector.
2. Turn on the ignition switch.
3. Read out a diagnosis code by observing how the warning lamp flashes.

Applicable systems

System name	Warning lamp name
A/T	Neutral position indicator lamp
ABS	ABS warning lamp
SS4 II	4WD warning lamp
Hydraulic Brake Booster(HBB)	Brake warning lamp

Indication of diagnosis code by warning lamp

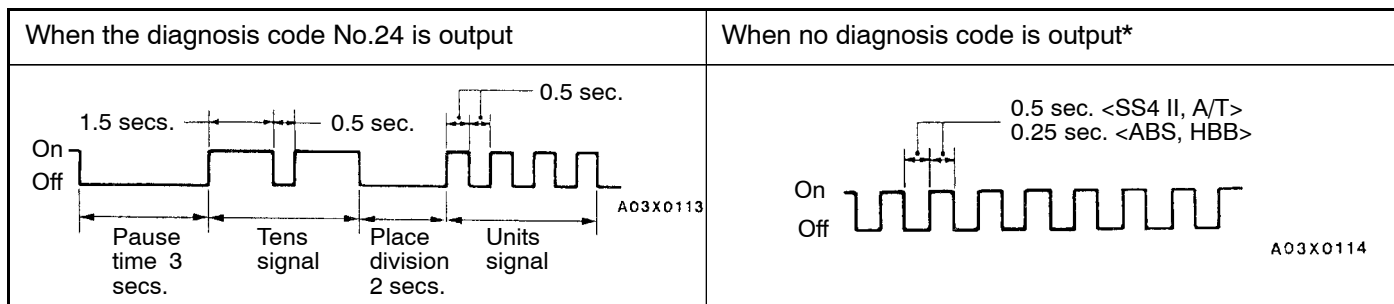

NOTE

*: Even if the ABS system is normal, removing the valve relay causes the diagnosis code No.52 to be output.

METHOD OF ERASING DIAGNOSIS CODES

WHEN USING THE MUT-II

Connect the MUT-II to the diagnosis connector and erase the diagnosis code.

Caution

Turn the ignition switch to "LOCK (OFF)" position before connecting or disconnecting the MUT-II.

WHEN NOT USING THE MUT-II

1. Turn the ignition switch to "LOCK(OFF)" position.
2. After disconnecting the battery cable from the battery (-) terminal for 10 seconds or more, reconnect the cable.
3. After the engine has warmed up, run it at idle for about 15 minutes.

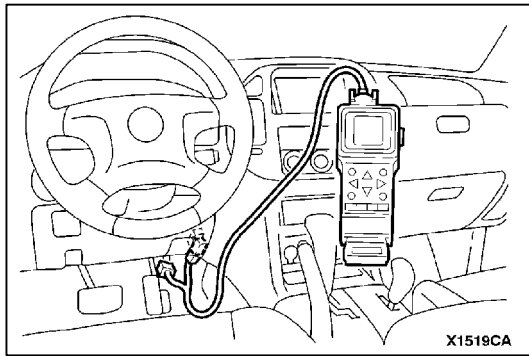
**INPUT SIGNAL CHECK <SWS>****WHEN USING THE MUT-II**

- (1) Connect the MUT-II to the diagnosis connector and erase the diagnosis code.

Caution

Turn the ignition switch to “LOCK (OFF)” position before connecting or disconnecting the MUT-II.

- (2) If the MUT-II buzzer sounds once when each switch is operated (ON/OFF), the input signal for that switch circuit system is normal.

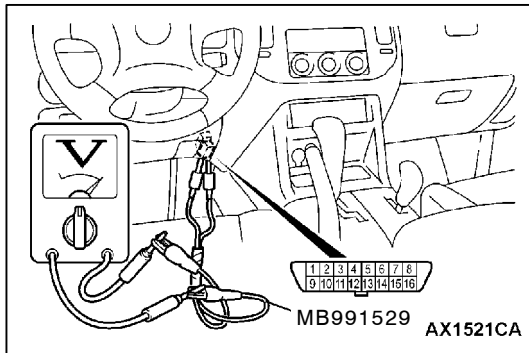
**WHEN USING A VOLTMETER**

- (1) Use the special tool to connect the ETACS terminal (terminal 9) and the earth terminals (terminals 4 and 5) of the diagnosis connector to the voltage meter.
- (2) If the needle of the voltage meter flickers once when each switch is operated (ON/OFF), the input signal for that switch circuit system is normal.

HOW TO USE THE INSPECTION PROCEDURES

The causes of a high frequency of problems occurring in electronic circuitry are generally the connectors, components, the ECU and the harnesses between connectors, in that order. These inspection procedures follow this order, and they first try to discover a problem with a connector or a defective component.

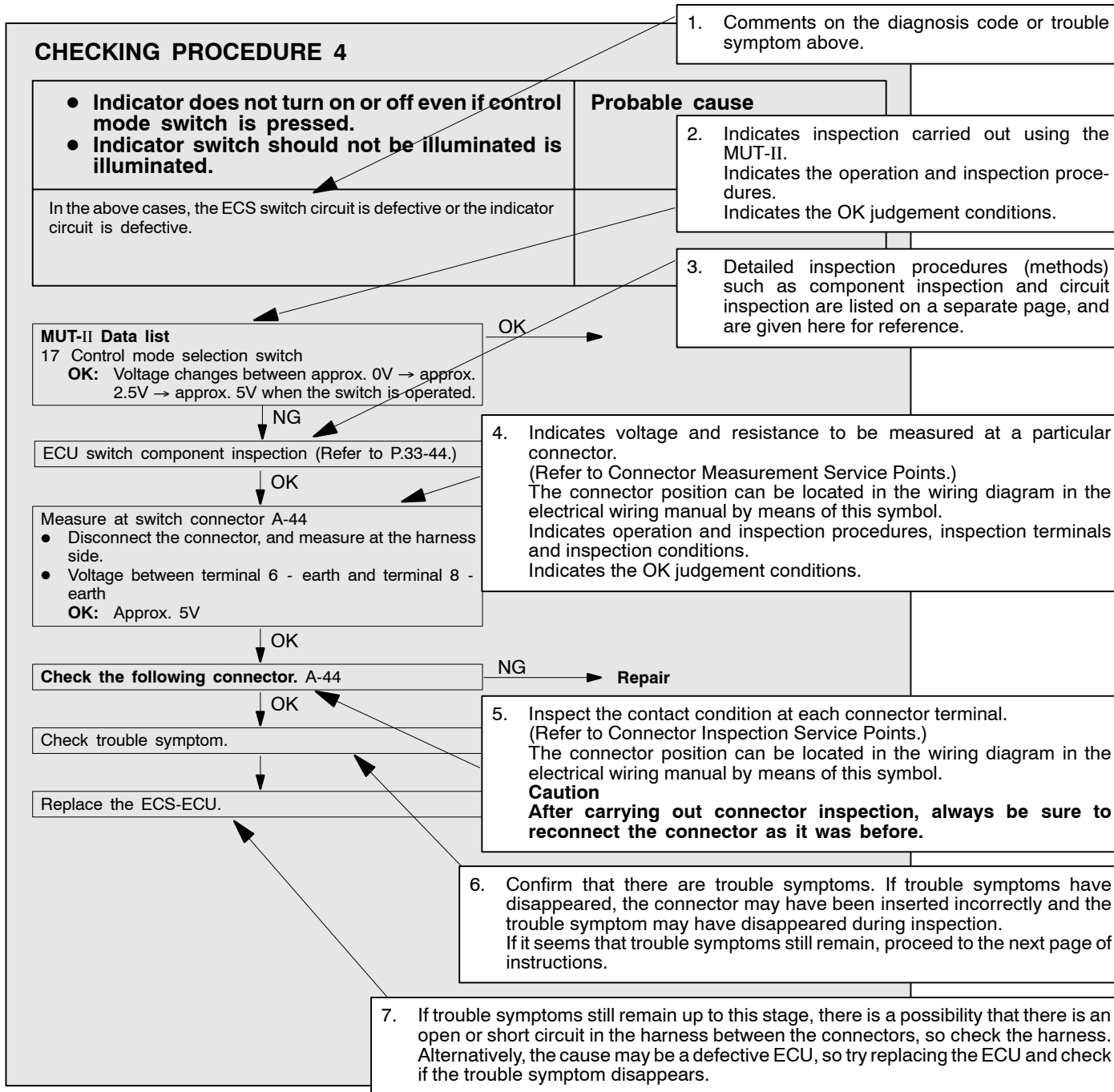

HARNESS INSPECTION

Check for an open or short circuit in the harness between the terminals which were defective according to the connector measurements. Carry out this inspection while referring to the electrical wiring manual. Here, "Check harness between power supply and terminal xx" also includes checking for blown fuses. For inspection service points when there is a blown fuse, refer to "Inspection Service Points for a Blown Fuse."

MEASURES TO TAKE AFTER REPLACING THE ECU

If the trouble symptoms have not disappeared even after replacing the ECU, repeat the inspection procedure from the beginning.

CONNECTOR MEASUREMENT SERVICE POINTS

Turn the ignition switch to OFF when connecting/disconnecting the connectors, and turn the ignition switch to ON when measuring if there are no instructions to be contrary.

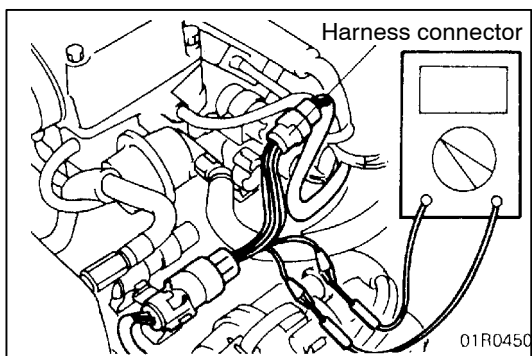

IF INSPECTING WITH THE CONNECTOR CONNECTED (WITH CIRCUIT IN A CONDITION OF CONTINUITY)

Waterproof Connectors

Be sure to use the special tool (harness connector). Never insert a test bar from the harness side, because to do so will reduce the waterproof performance and result in corrosion.

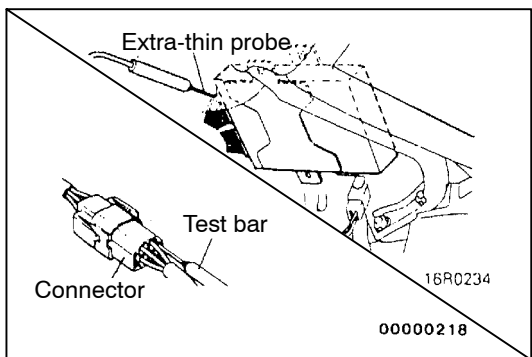

Ordinary (non-waterproof) Connectors

Check by inserting the test bar from the harness side. Note that if the connector (control unit, etc.) is too small to permit insertion of the test bar, it should not be forced; use a special tool (the extra-thin probe in the harness set for checking for this purpose).

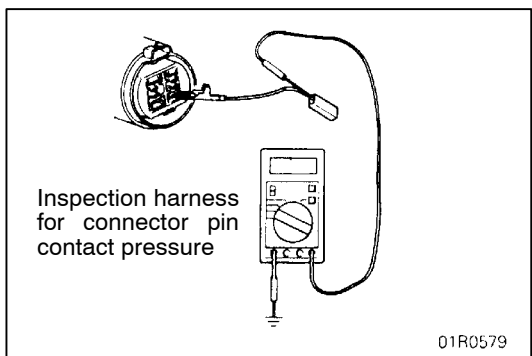

IF INSPECTING WITH THE CONNECTOR DISCONNECTED <When Inspecting a Female Pin>

Use the special tool (inspection harness for connector pin contact pressure in the harness set for inspection). The inspection harness for connector pin contact pressure should be used. The test bar should never be forcibly inserted, as it may cause a defective contact.

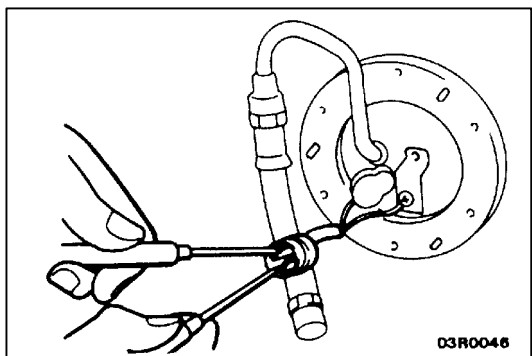

<When Inspecting a Male Pin>

Touch the pin directly with the test bar.

Caution

At this time, be careful not to short the connector pins with the test bars. To do so may damage the circuits inside the ECU.

Connector disconnected or improperly connected

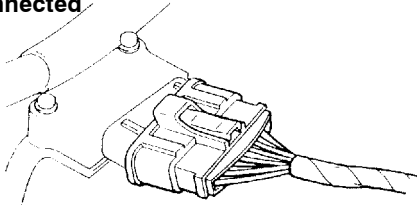

Defective connector contact

16S0256

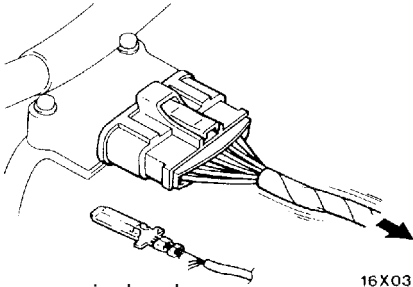

Harness wire breakage at terminal section

16X0369

Low contact pressure

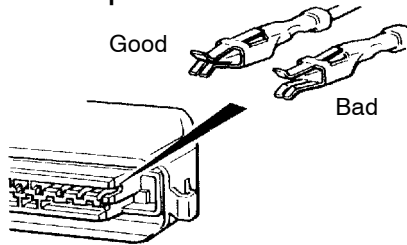

16S0254
00000219

CONNECTOR INSPECTION

VISUAL INSPECTION

- Connector is disconnected or improperly connected
- Connector pins are pulled out
- Due to harness tension at terminal section
- Low contact pressure between male and female terminals
- Low connection pressure due to rusted terminals or foreign matter lodged in terminals

CONNECTOR PIN INSPECTION

If the connector pin stopper is damaged, the terminal connections (male and female pins) will not be perfect even if the connector body is connected, and the pins may pull out of the reverse side of the connector. Therefore, gently pull the harnesses one by one to make sure that no pins pull out of the connector.

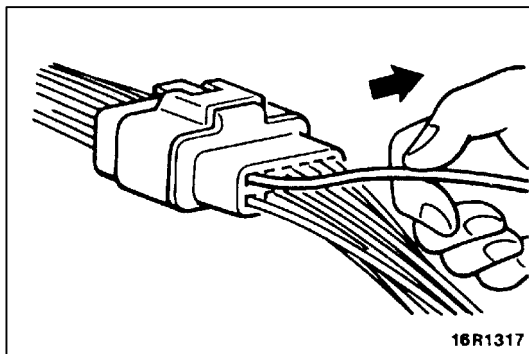

16R1317

CONNECTOR ENGAGEMENT INSPECTION

Use the special tool (connector pin connection pressure inspection harness of the inspection harness set) to inspect the engagement of the male pins and females pins. (Pin drawing force : 1 N or more)

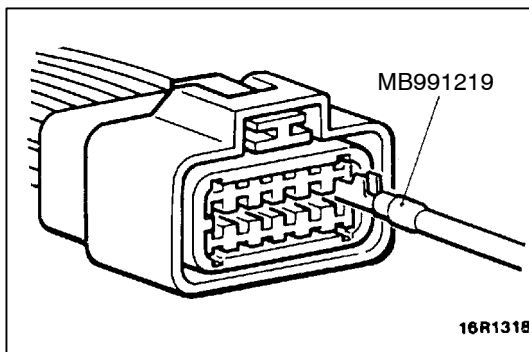

16R1318

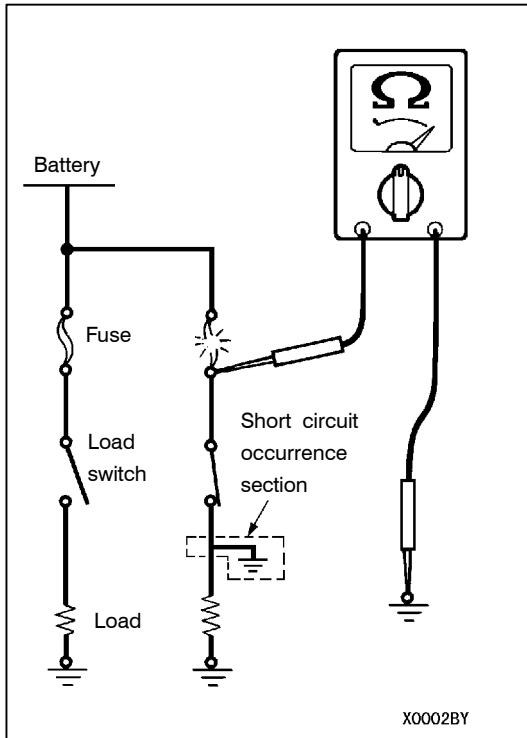

INSPECTION SERVICE POINTS FOR A BLOWN FUSE

Remove the blown fuse and measure the resistance between the load side of the blown fuse and the earth. Set the switches of all circuits which are connected to this fuse to a condition of continuity. If the resistance is almost 0 Ω at this time, there is a short somewhere between these switches and the load. If the resistance is not 0 Ω, there is no short at the present time, but a momentary short has probably caused the fuse to blow.

The main causes of a short circuit are the following.

- Harness being clamped by the vehicle body
- Damage to the outer casing of the harness due to wear or heat
- Water getting into the connector or circuitry
- Human error (mistakenly shorting a circuit, etc.)

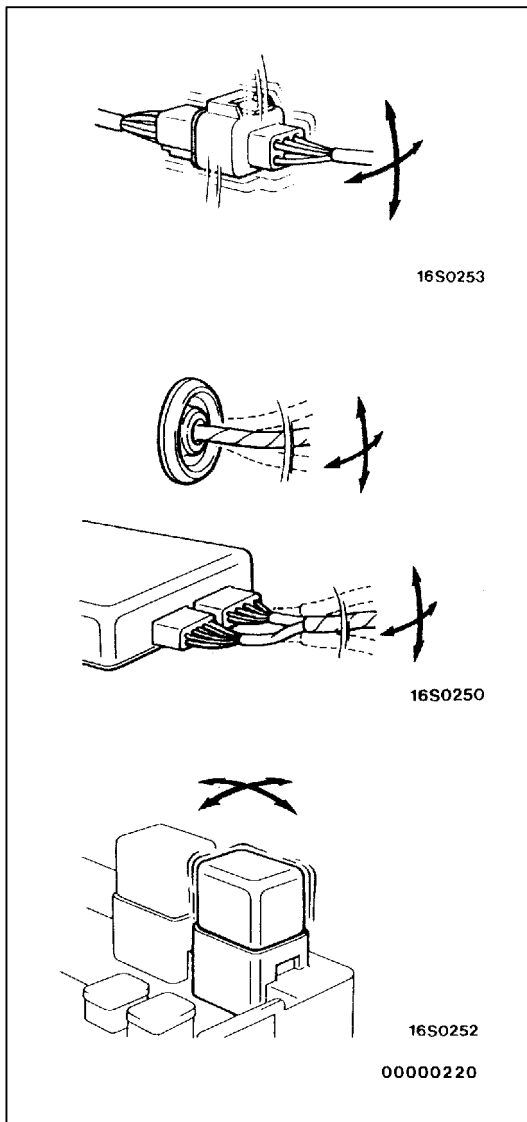

POINTS TO NOTE FOR INTERMITTENT MALFUNCTIONS

Intermittent malfunctions often occur under certain conditions, and if these conditions can be ascertained, determining the cause becomes simple. In order to ascertain the conditions under which an intermittent malfunction occurs, first ask the customer for details about the driving conditions, weather conditions, frequency of occurrence and trouble symptoms, and then try to recreate the trouble symptoms. Next, ascertain whether the reason why the trouble symptom occurred under these conditions is due to vibration, temperature or some other factor. If vibration is thought to be the cause, carry out the following checks with the connectors and components to confirm whether the trouble symptom occurs.

The objects to be checked are connectors and components which are indicated by inspection procedures or given as probable causes (which generates diagnosis codes or trouble symptoms.)

- Gently shake the connector up, down and to the left and right.
- Gently shake the wiring harness up, down and to the left and right.
- Gently rock each sensor and relay, etc. by hand.
- Gently shake the wiring harness at suspensions and other moving parts.

NOTE

If determining the cause is difficult, the flight recorder function of the MUT-II can also be used.

TREATMENT BEFORE/AFTER FORDING A STREAM

INSPECTION AND SERVICE BEFORE FORDING A STREAM

- Vehicles which are driven through water, or which may possibly be driven through water, should be subjected to the following inspections and maintenance procedures in advance.
- Inspect the dust boot and breather hose for cracks or damage, and replace them if cracks or damage are found.

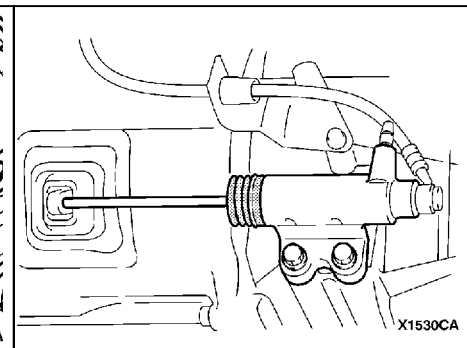
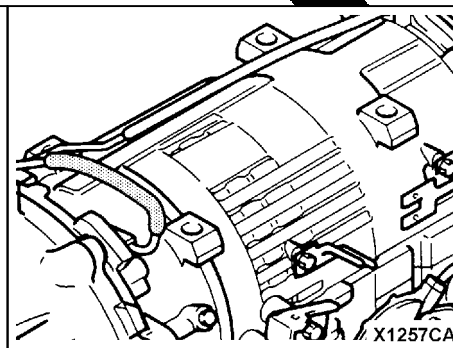
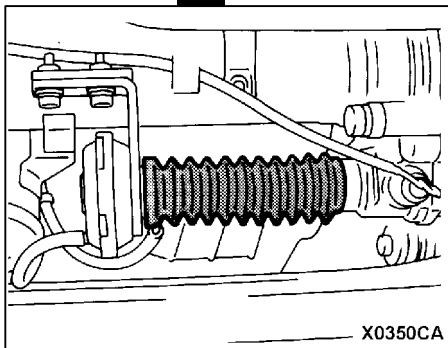
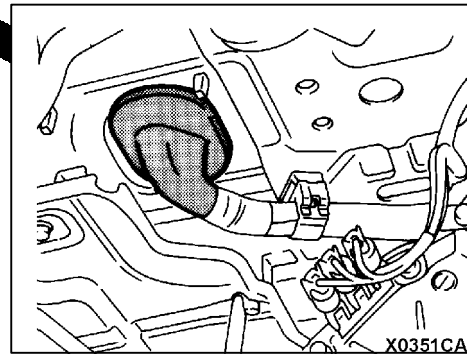
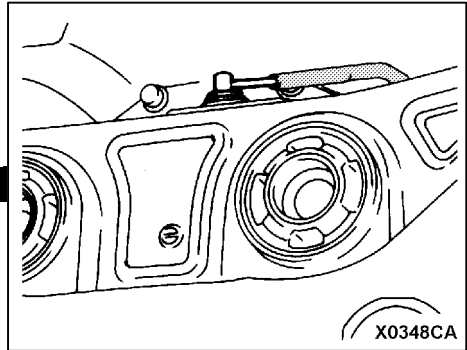
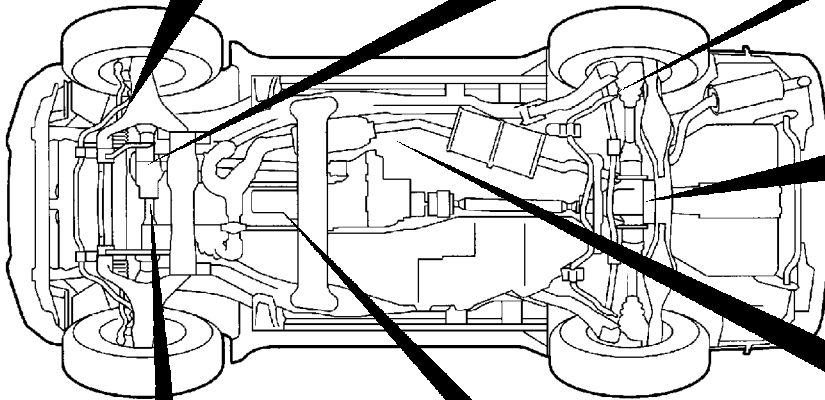
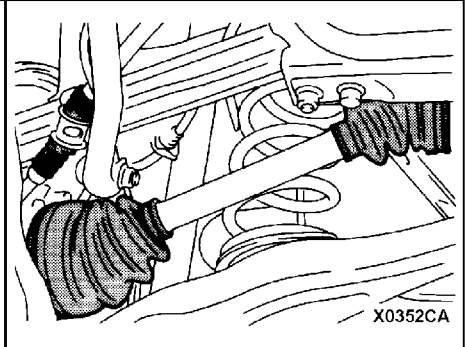
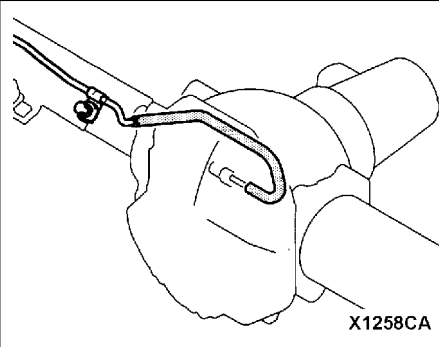
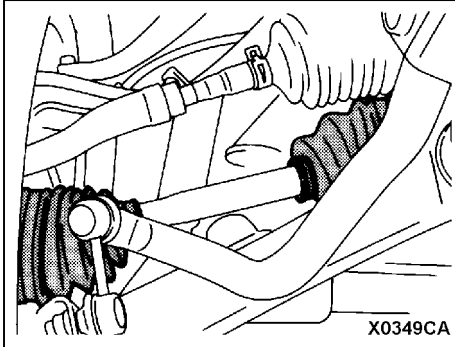

INSPECTION AND SERVICE AFTER FORDING A STREAM

After fording a stream, check the following points. If abnormal condition is evident, clean, replace or lubricate.

- Check for water, mud, sand, etc. in the rear brake drum, clutch housing, starter motor, brake pipe and fuel pipe.

- Check for water in the fluid or oil inside the front differential, rear differential, transmission and transfer.
- Check all boots and breather hoses for cracks and damage.

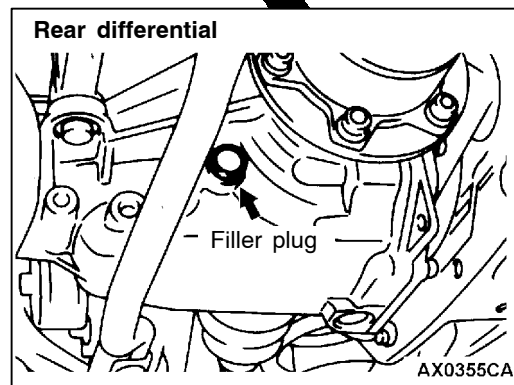
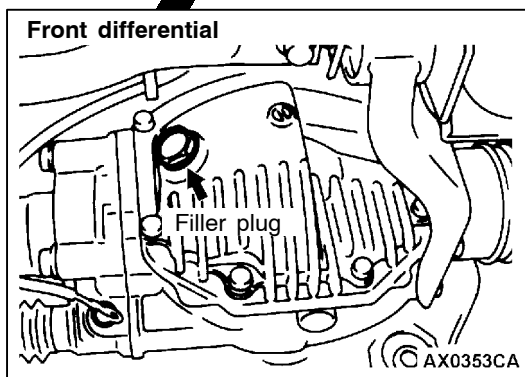
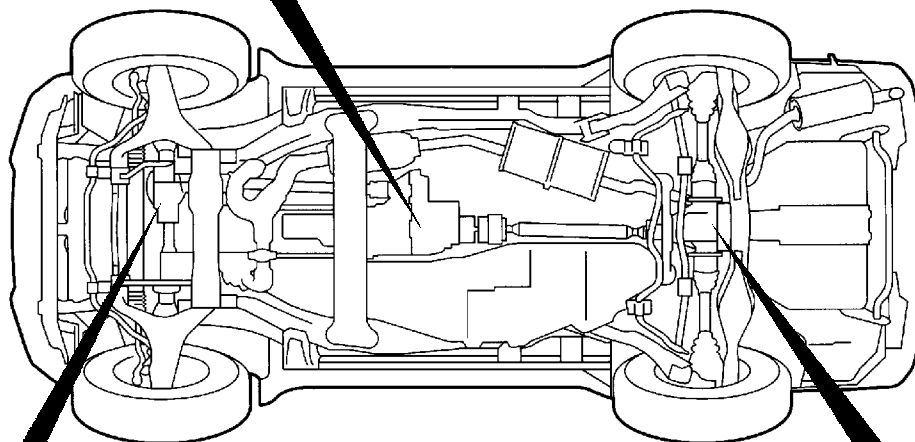
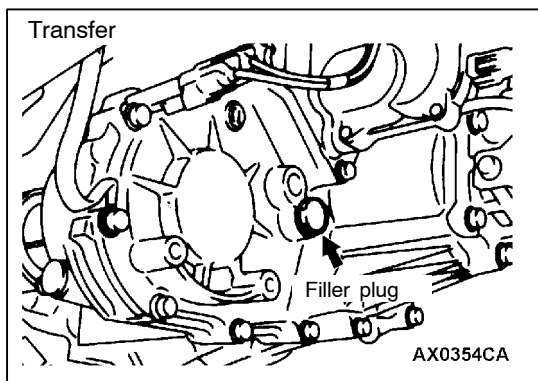

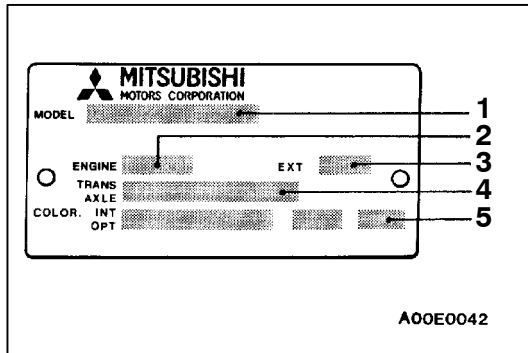
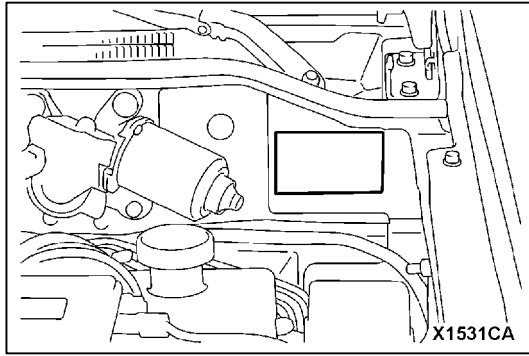

VEHICLE IDENTIFICATION

VEHICLE INFORMATION CODE PLATE

LOCATION

Vehicle information code plate is riveted on the toeboard inside the engine compartment.

CODE PLATE DESCRIPTION

The plate shows model code, engine model, transmission model, and body colour code.

No.	Item	Contents	
1	MODEL	V65W	V65W: Vehicle model
		MYHCL6	MYHCL6: Model series
2	ENGINE	6G74GDI	Engine model
3	EXT	S74B	Exterior code
4	TRANS AXLE	V5A51	Transmission code
5	COLOR INT OPT	S74 15Q Z06	S74: Body colour code
			15Q: Interior code
			Z06: Equipment code

For monotone colour vehicles, the body colour code shall be indicated. For two-tone or three-way two-tone colour vehicles, each colour code only shall be indicated in series.

MODELS

<Short wheelbase>

Model code		Engine model	Transmission model	Fuel supply system
V64W	MNDFL6	4D56 Intercooler Turbo (2,477 mL)	V5MT1 <5M/T>	Injection
	MNHFL6		V5M31 <5M/T>	
	MNHFR6			
	MNXFL6			
	MNXFR6			

Model code		Engine model	Transmission model	Fuel supply system
V68W	MNDFL6	4M41-DOHC Intercooler Turbo (3,200 mL)	V5M31 <5M/T>	Electronically-controlled high pressure fuel distribution
	MNHFL6			
	MYHFL6		V5A51 <5A/T>	
	MNXFL6		V5M31 <5M/T>	
	MNXFR6			
	MYXFL6		V5A51 <5A/T>	
	MYXFR6			
V65W	MNHCL6	6G74GDI (3,496 mL)	V5M31 <5M/T>	GDI
	MNHCR6			
	MYHCL6		V5A51 <5A/T>	
	MYHCR6			
	MNXCL6		V5M31 <5M/T>	
	MNXCR6			
	MYXCL6		V5A51 <5A/T>	
	MYXCR6			

<Long wheelbase>

Model code		Engine model	Transmission model	Fuel supply system
V74W	LNDFL6	4D56 Intercooler Turbo (2,477 mL)	V5MT1 <5M/T>	Inyection
	LNHFL6		V5M31 <5M/T>	
	LNXFL6			
V78W	LNDFL6	4M41-DOHC Intercooler Turbo (3,200 mL)	V5M31 <5M/T>	Electronically-controlled high pressure fuel distribution
	LNHFL6			
	LNHFR6			
	LYHFL6		V5A51 <5A/T>	
	LYHFR6			
	LNXFL6		V5M31 <5M/T>	
	LNXFR6			
	LYXFL6		V5A51 <5A/T>	
	LYXFR6			

Model code		Engine model	Transmission model	Fuel supply system
V75W	LNHCL6	6G74GDI (3,496 mL)	V5M31 <5M/T>	GDI
	LNHCR6		V5A51 <5A/T>	
	LYHCL6			
	LYHCR6		V5M31 <5M/T>	
	LNXCL6			
	LNXCR6		V5A51 <5A/T>	
	LYXCL6			
	LYXCR6			

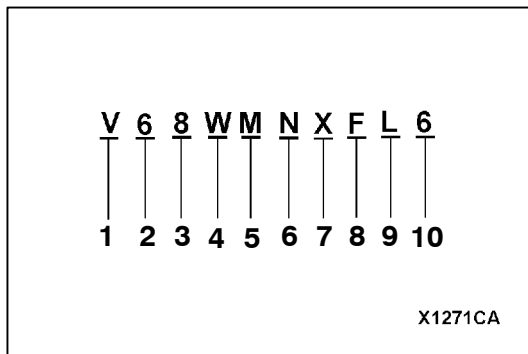

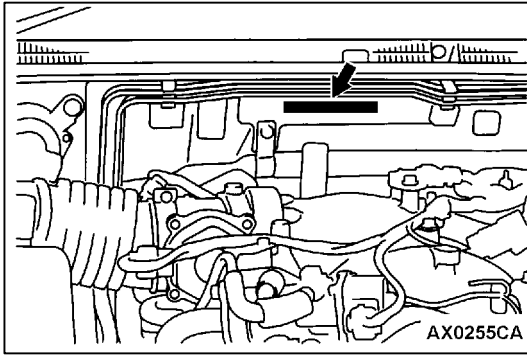

MODEL CODE

No.	Items	Contents
1	Development	V: MITSUBISHI PAJERO
2	wheelbase	6: Short wheelbase 7: Long wheelbase
3	Engine type	4: 2,477 mL diesel engine 5: 3,496 mL petrol engine 8: 3,200 mL diesel engine
4	Sort	W: Wagon
5	Body style	M: 3-door L: 5-door
6	Transmission type	N: 5-speed manual transmission Y: 5-speed automatic transmission
7	Trim level	D: GL H: GLX X: GLS
8	Specification engine feature	C: GDI F: Intercooler Turbocharger
9	Steering wheel location	L: Left hand R: Right hand
10	Destination	6: For Europe



CHASSIS NUMBER

The chassis number is stamped on the toeboard inside the engine compartment.

J M B M N V6 4 W 1 J 00001

 1 2 3 4 5 6 7 8 9 10 11

X1428CA

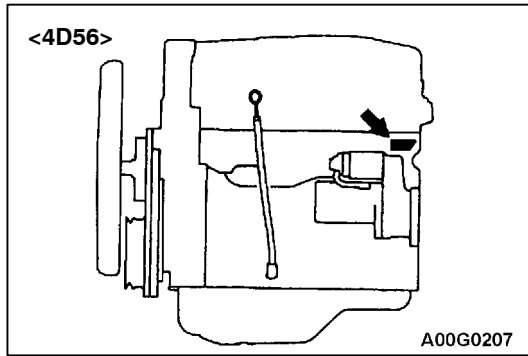
No.	Items	Contents
1	Fixed figure	J Asia
2	Distribution channel	M Japan channel
3	Destination	A For Europe, right hand drive
		B For Europe, left hand drive
4	Body style	M 3-door
		L 5-door
5	Transmission type	N 5-speed manual transmission
		Y 5-speed automatic transmission
6	Development order	V6 MITSUBISHI PAJERO short wheelbase
		V7 MITSUBISHI PAJERO long wheelbase
7	Engine	4 4D56: 2,477 mL diesel engine
		5 6G74: 3,496 mL petrol engine
		8 4M41: 3,200 mL diesel engine
8	Sort	W Station wagon
9	Model year	1 2001
10	Plant	J Nagoya-3
11	Serial number	-



ENGINE MODEL NUMBER

1. The engine model number is stamped at the cylinder block as shown in the following.

Engine model	Engine displacement mL
4D56	2,477
4M41	3,200
6G74	3,496

2. The engine serial number is stamped near the engine model number.

Engine serial number	AA0201 to YY9999
----------------------	------------------

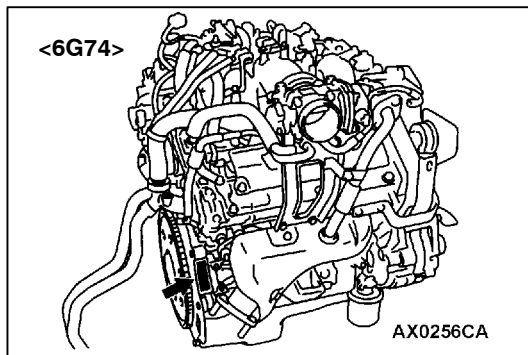
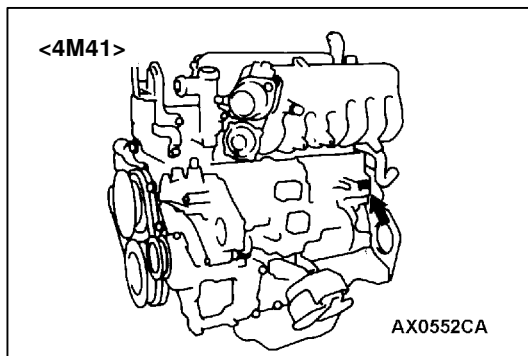

THEFT PROTECTION LABEL

FOR MAIN OUTER PANELS

[FOR ORIGINAL PARTS]

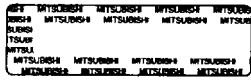

[FOR REPLACEMENT PARTS]



X1629CA

THEFT PROTECTION<R.H.D.>

In order to protect against theft, a Vehicle Identification Number (VIN) is attached as a plate or label to the following major parts of the main outer panels:

Fender, Doors, Back door, Quarter panel, Hood, Bumpers

In addition, a theft-protection label is attached to replacement parts for the body outer panel main components.

Cautions regarding panel repairs:

1. When repainting original parts, do so after first masking the theft-protection label, and, after painting, be sure to peel off the masking tape.
2. The theft-protection label for replacement parts is covered by masking tape, so such parts can be painted as is. The masking tape should be removed after painting is finished.
3. The theft-protection label should not be removed from original parts or replacement parts.

LOCATIONS

TARGET AREA (A: FOR ORIGINAL EQUIPMENT PARTS, B: FOR REPLACEMENT PARTS)

Fender

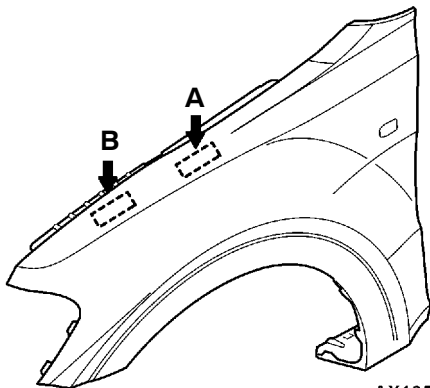

AX1658CA

The illustration indicates left outer side. Right side is symmetrically opposite.

Quarter panel

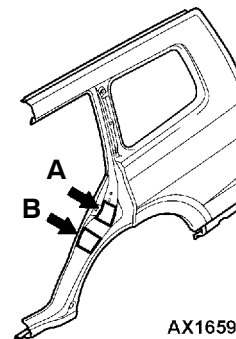

AX1659CA

The illustration indicates left outer side. Right side is symmetrically opposite.

Front door

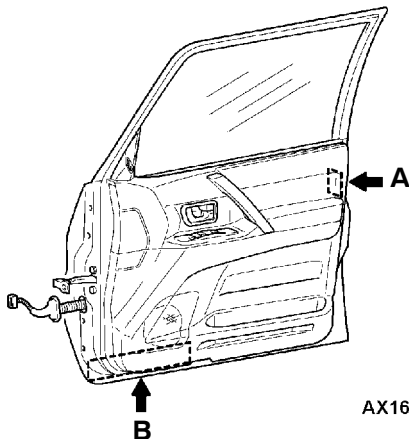

AX1660CA

The illustration indicates right outer side. Left side is symmetrically opposite.

Rear door

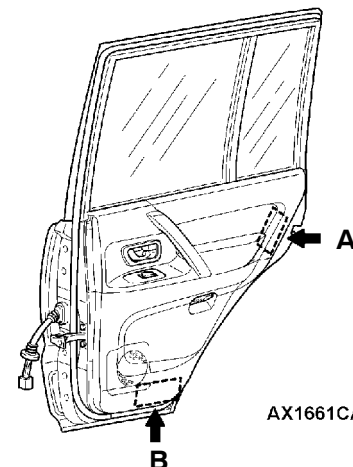

AX1661CA

The illustration indicates right outer side. Left side is symmetrically opposite.

TARGET AREA (A: FOR ORIGINAL EQUIPMENT PARTS, B: FOR REPLACEMENT PARTS)

Hood

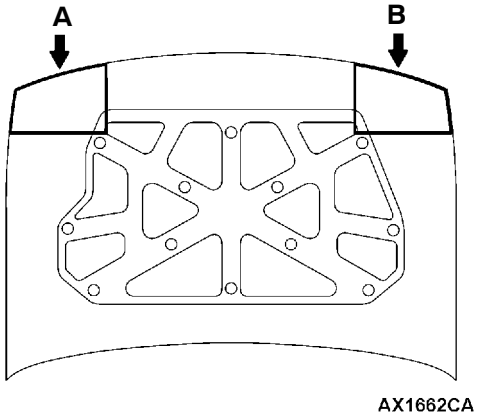

Back door

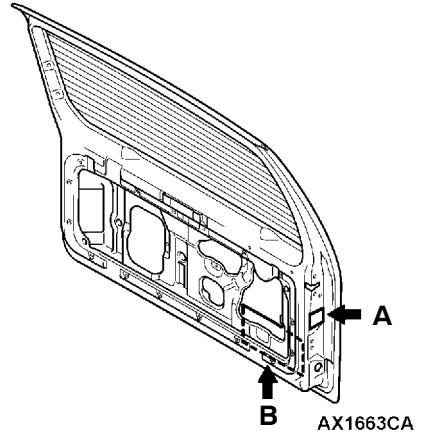

Front bumper

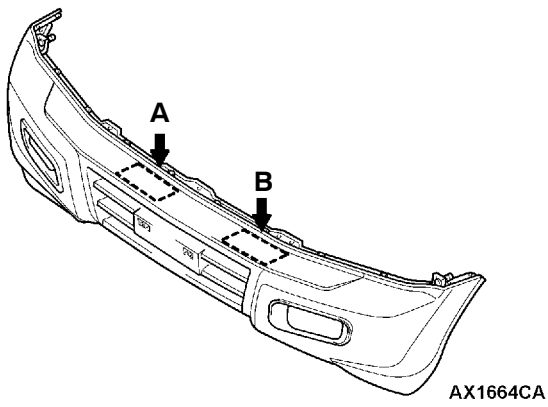

Rear bumper

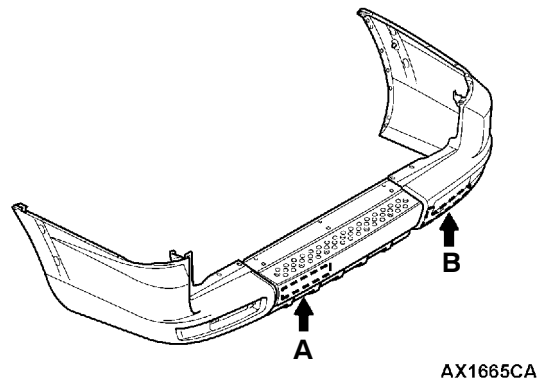

MAJOR SPECIFICATIONS

<Short wheelbase>

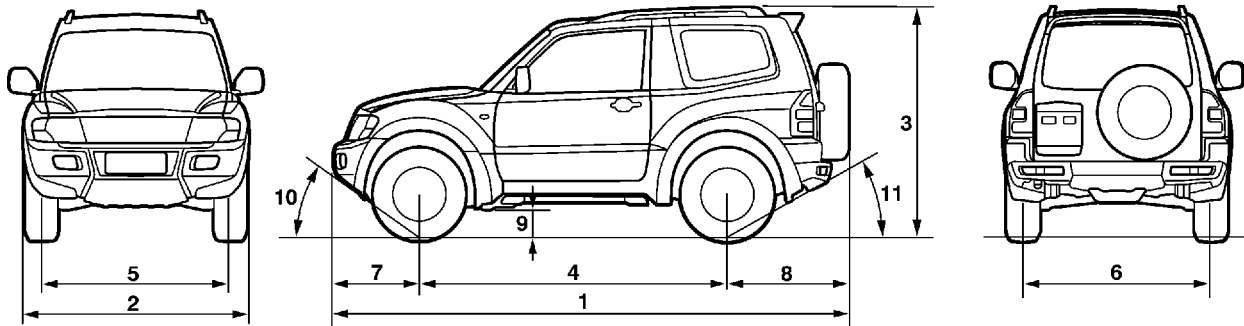

X1508CA

Items			V64W			V68W		
			MNDFL6	MNHFL6, MNHFR6	MNXFL6, MNXFR6	MNDFL6	MNHFL6	
Vehicle dimensions mm	Overall length	1	4,260		4,280	4,260		
	Overall width	2	1,845		1,875	1,845		
	Overall height (unladen)	3	1,845, 1,875*1					
	Wheelbase	4	2,545					
	Track-front	5	1,560					
	Track-rear	6	1,560					
	Overhang-front	7	710					
	Overhang-rear	8	1,005*2, 1,025*3					
	Ground clearance (unladen)	9	235			225		
	Angle of approach degrees	10	42*					
Angle of departure degrees	11	33.5*						
Vehicle weight kg	Kerb weight		1,865	1,900	1,920	1,975	1,980	
	Max. gross vehicle weight		2,510					
	Max. axle weight rating-front		1,070	1,090	1,100	1,165		
	Max. axle weight rating-rear		1,440	1,420	1,410	1,345		
Seating capacity			5					
Engine	Model No.		4D56 Intercooler Turbo			4M41-DOHC Intercooler Turbo		
	Total displacement mL		2,477			3,200		
Transmission	Model No.		V5MT1	V5M31				
	Type		5-speed manual					
Fuel system	Fuel supply system		Inyection			Electronically-controlled high pressure fuel distribution		

NOTE:

*1: Vehicles with roof rails

*2: Vehicles with 235/80R16 Tyre

*3: Vehicles with 265/70R16 Tyre

Items			V68W			V65W	
			MYHFL6	MNXFL6, MNXFR6	MYXFL6, MYXFR6	MNHCL6, MNHCR6	MYHCL6, MYHCR6
Vehicle dimensions mm	Overall length	1	4,260	4,280			
	Overall width	2	1,845	1,875		1,845	
	Overall height (unladen)	3	1,845,1,875* ¹				
	Wheelbase	4	2,545				
	Track-front	5	1,560				
	Track-rear	6	1,560				
	Overhang-front	7	710				
	Overhang-rear	8	1,005* ² , 1,025* ³				
	Ground clearance (unladen)	9	225			235	
	Angle of approach degrees	10	42*				
	Angle of departure degrees	11	33.5*				
Vehicle weight kg	Kerb weight		1,980	2,000		1,915	
	Max. gross vehicle weight		2,510				
	Max. axle weight rating-front		1,165	1,170		1,075	
	Max. axle weight rating-rear		1,345	1,340		1,435	
Seating capacity			5				
Engine	Model No.		4M41-DOHC Intercooler Turbo			6G74GDI	
	Total displacement mL		3,200			3,496	
Transmission	Model No.		V5A51	V5M31	V5A51	V5M31	
	Type		5-speed automatic	5-speed manual	5-speed automatic	5-speed manual	
Fuel system	Fuel supply system		Electronically-controlled high pressure fuel distribution			GDI	

NOTE:

*1: Vehicles with roof rails

*2: Vehicles with 235/80R16 Tyre

*3: Vehicles with 265/70R16 Tyre

Items			V65W	
			MNXCL6, MNXCR6	MYXCL6, MYXCR6
Vehicle dimensions mm	Overall length	1	4,280	
	Overall width	2	1,875	
	Overall height (unladen)	3	1,845,1,875* ¹	
	Wheelbase	4	2,545	
	Track-front	5	1,560	
	Track-rear	6	1,560	
	Overhang-front	7	710	
	Overhang-rear	8	1,005* ² , 1,025* ³	
	Ground clearance (unladen)	9	235	
	Angle of approach degrees	10	42*	
	Angle of departure degrees	11	33.5*	
Vehicle weight kg	Kerb weight	1,935		
	Max. gross vehicle weight	2,510		
	Max. axle weight rating-front	1,080		
	Max. axle weight rating-rear	1,430		
Seating capacity		5		
Engine	Model No.	6G74GDI		
	Total displacement mL	3,496		
Transmission	Model No.	V5M31	V5A51	
	Type	5-speed manual	5-speed automatic	
Fuel system	Fuel supply system	GDI		

NOTE:

*1: Vehicles with roof rails

*2: Vehicles with 235/80R16 Tyre

*3: Vehicles with 265/70R16 Tyre

<Long wheelbase>

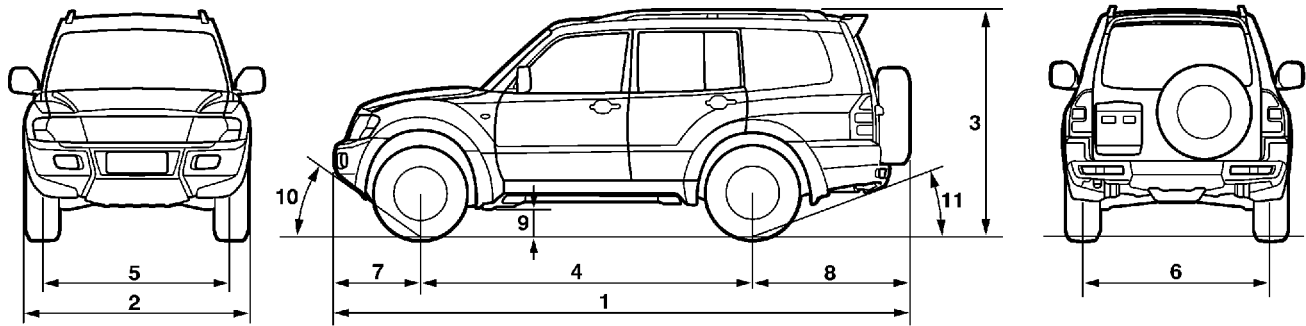

X1509CA

Items			V74W			V78WL	
			LNDFL6	LNHFL6	LNXL6	LNDFL6	LNHFL6, LNHFR6
Vehicle dimensions mm	Overall length	1	4,775			4,795	4,775
	Overall width	2	1,845			1,875	1,845
	Overall height (unladen)	3	1,855, 1,885* ¹				
	Wheelbase	4	2,780				
	Track-front	5	1,560				
	Track-rear	6	1,560				
	Overhang-front	7	710				
	Overhang-rear	8	1,285* ² , 1,305* ³				
	Ground clearance (unladen)	9	235			225	
	Angle of approach degrees	10	42*				
	Angle of departure degrees	11	24*				
Vehicle weight kg	Kerb weight		2,015	2,055	2,090	2,120	2,125
	Max. gross vehicle weight		2,760				
	Max. axle weight rating-front		1,110	1,110	1,125	1,160	
	Max. axle weight rating-rear		1,650	1,650	1,635	1,600	
Seating capacity			7				
Engine	Model No.		4D56 Intercooler Turbo			4M41-DOHC Intercooler Turbo	
	Total displacement mL		2,477			3,200	
Transmission	Model No.		V5MT1	V5M31			
	Type		5-speed manual				
Fuel system	Fuel supply system		Injection			Electronically-controlled high pressure fuel distribution	

NOTE:

*1: Vehicles with roof rails

*2: Vehicles with 235/80R16 Tyre

*3: Vehicles with 265/70R16 Tyre

Items			V78W			V75W	
			LYHFL6, LYHFR6	LNFL6, LNFR6	LYXFL6, LYXFR6	LNHCL6, LNHCR6	LYHCL6, LYHCR6
Vehicle dimensions mm	Overall length	1	4,775	4,795			
	Overall width	2	1,845	1,875		1,845	
	Overall height (unladen)	3	1,855,1,885* ¹				
	Wheelbase	4	2,780				
	Track-front	5	1,560				
	Track-rear	6	1,560				
	Overhang-front	7	710				
	Overhang-rear	8	1,285* ² , 1,305* ³				
	Ground clearance (unladen)	9	225			235	
	Angle of approach degrees	10	42*				
	Angle of departure degrees	11	24*				
Vehicle weight kg	Kerb weight		2,125	2,155		2,060	
	Max. gross vehicle weight		2,760	2,800		2,760	
	Max. axle weight rating-front		1,160			1,110	
	Max. axle weight rating-rear		1,600			1,650	
Seating capacity			7				
Engine	Model No.		4M41-DOHC Intercooler Turbo			6G74GDI	
	Total displacement mL		3,200			3,496	
Transmission	Model No.		V5A51	V5M31	V5A51	V5M31	
	Type		5-speed automatic	5-speed manual	5-speed automatic	5-speed manual	
Fuel system	Fuel supply system		Electronically-controlled high pressure fuel distribution			GDI	

NOTE:

*1: Vehicles with roof rails

*2: Vehicles with 235/80R16 Tyre

*3: Vehicles with 265/70R16 Tyre

Items			V75W	
			LNXCL6, LNXCR6	LYXCL6, LYXCR6
Vehicle dimensions mm	Overall length	1	4,795	
	Overall width	2	1,875	
	Overall height (unladen)	3	1,855,1,885* ¹	
	Wheelbase	4	2,780	
	Track-front	5	1,560	
	Track-rear	6	1,560	
	Overhang-front	7	710	
	Overhang-rear	8	1,285* ² , 1,305* ³	
	Ground clearance (unladen)	9	235	
	Angle of approach degree	10	42*	
	Angle of departure degree)	11	24*	
Vehicle weight kg	Kerb weight	2,095		
	Max. gross vehicle weight	2,760		
	Max. axle weight rating-front	1,110		
	Max. axle weight rating-rear	1,650		
Seating capacity		7		
Engine	Model No.	6G74GDI		
	Total displacement mL	3,496		
Transmission	Model No.	V5M31	V5A51	
	Type	5-speed manual	5-speed automatic	
Fuel system	Fuel supply system	GDI		

NOTE:

*1: Vehicles with roof rails

*2: Vehicles with 235/80R16 Tyre

*3: Vehicles with 265/70R16 Tyre

PRECAUTIONS BEFORE SERVICE

SUPPLEMENTAL RESTRAINT SYSTEM (SRS)

1. Items to follow when servicing SRS
 - (1) Be sure to read GROUP 52B - Supplemental Restraint System (SRS).
For safe operations, please follow the directions and heed all warnings.
 - (2) Wait at least 60 seconds after disconnecting the battery cable before doing any further work.
The SRS system is designed to retain enough voltage to deploy the air bag even after the battery has been disconnected. Serious injury may result from unintended air bag deployment if work is done on the SRS system immediately after the battery cable is disconnected.
 - (3) Warning labels must be heeded when servicing or handling SRS components. Warning labels are located in the following locations.
 - Hood
 - Sun visor
 - Glove box
 - SRS-ECU
 - Steering wheel
 - Steering gearbox
 - Air bag module (driver's side and front passenger's side)
 - Front impact sensor
 - Clock spring
 - Side air bag module
 - Side impact sensor
 - (4) Always use the designated special tools and test equipment.
 - (5) Store components removed from the SRS in a clean and dry place.
The air bag module should be stored on a flat surface and placed so that the pad surface is facing upward.
Do not place anything on top of it.
 - (6) Never attempt to disassemble or repair the SRS components (SRS-ECU, air bag module, clock spring).
 - (7) Whenever you finish servicing the SRS, check the SRS warning lamp operation to make sure that the system functions properly.
 - (8) Be sure to deploy the air bag before disposing of the air bag module or disposing of a vehicle equipped with an air bag. (Refer to GROUP 52B - Air Bag Module Disposal Procedures.)
2. Observe the following when carrying out operations on places where SRS components are installed, including operations not directly related to the SRS air bag.
 - (1) When removing or installing parts do not allow any impact or shock to the SRS components.
 - (2) SRS components should not be subjected to heat, so remove the SRS components before drying or baking the vehicle after painting.
 - SRS-ECU, air bag module, clock spring, front and side impact sensors: 93°C or moreAfter re-installing them, check the SRS warning lamp operation to make sure that the system functions properly.

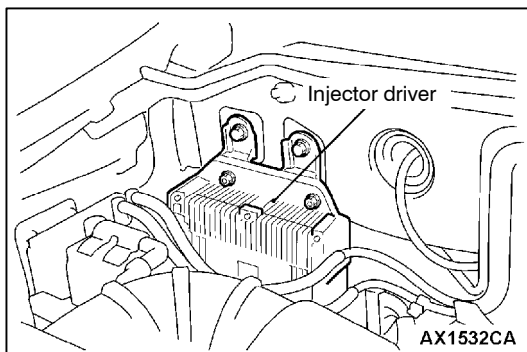

SERVICING INJECTOR DRIVER

After driving the vehicle, the injector driver will be hot. In addition, high voltages and high currents are supplied to the injector driver and the injectors while the engine is running, so take sufficient care when handling the injector driver and surrounding components at such times.

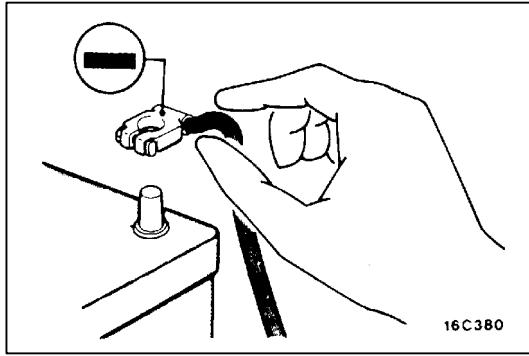

SERVICING THE ELECTRICAL SYSTEM

Before replacing a component related to the electrical system and before undertaking any repair procedures involving the electrical system, be sure to first disconnect the negative (-) cable from the battery in order to avoid damage caused by short-circuiting.

Caution

Before connecting or disconnecting the negative (-) cable, be sure to turn off the ignition switch and the lighting switch.

(If this is not done, there is the possibility of semiconductor parts being damaged.)

APPLICATION OF ANTI-CORROSION AGENTS AND UNDERCOATS

If oil or grease gets onto the oxygen sensor, it will cause a drop in the performance of the sensor.

Cover the oxygen sensor with a protective cover when applying anti-corrosion agents and undercoats.

PRE-INSPECTION CONDITION

“Pre-inspection condition” refers to the condition that the vehicle must be in before proper engine inspection can be carried out. If you see the words “Set the vehicle to the pre-inspection condition”. in this manual, it means to set the vehicle to the following condition.

- Engine coolant temperature: 80-90°C
- Lamps, electric cooling fan and all accessories: OFF
- M/T: Neutral
- A/T: P range

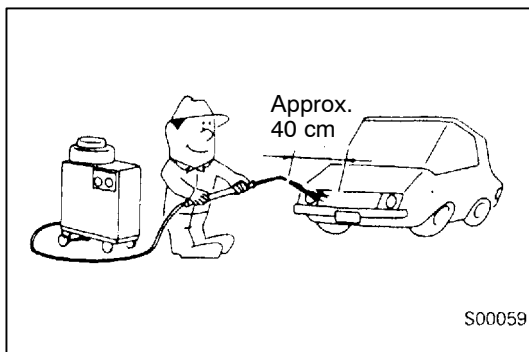

VEHICLE WASHING

If high-pressure car-washing equipment or steam car-washing equipment is used to wash the vehicle, be sure to note the following information in order to avoid damage to plastic components, etc.

- Spray nozzle distance: Approx. 40 cm or more
- Spray pressure: 3,900 kPa or less
- Spray temperature: 82°C or less
- Time of concentrated spray to one point: within 30 sec.

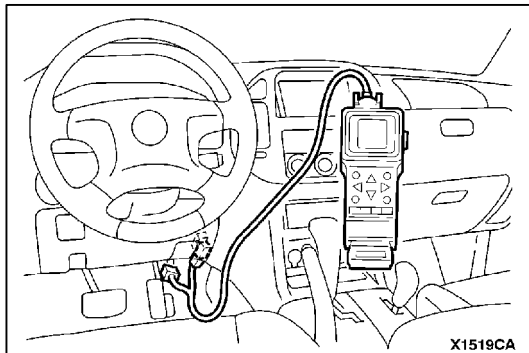
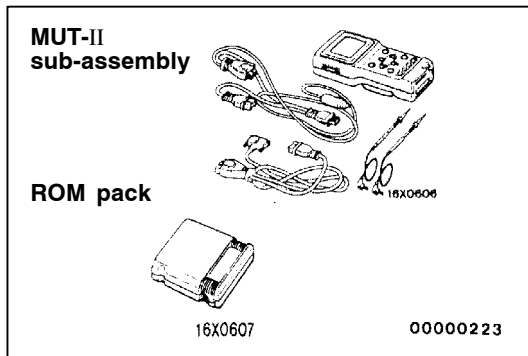

MUT-II

Refer to the "MUT-II REFERENCE MANUAL" or "MUT-II OPERATING INSTRUCTIONS" for instructions on handling the MUT-II.

Connect the MUT-II to the diagnosis connector as shown in the illustration.

Caution

Connection and disconnection of the MUT-II should always be made with the ignition switch in the "LOCK(OFF)" position.

IN ORDER TO PREVENT VEHICLES FROM FIRE

"Improper installation of electrical or fuel related parts could cause a fire. In order to retain the high quality and safety of the vehicle, it is important that any accessories that may be fitted or modifications/repairs that may be carried out which involve the electrical or fuel systems, **MUST** be carried out in accordance with MMC's information/Instructions".

ENGINE OILS

Health Warning

Prolonged and repeated contact with mineral oil will result in the removal of natural fats from the skin, leading to dryness, irritation and dermatitis. In addition, used engine oil contains potentially harmful contaminants which may cause skin cancer. Adequate means of skin protection and washing facilities must be provided.

Recommended Precautions

The most effective precaution is to adapt working practices which prevent, as far as practicable, the risk of skin contact with mineral oils, for example by using enclosed systems for handling used engine oil and by degreasing components, where practicable, before handling them.

Other precautions:

- Avoid prolonged and repeated contact with oils, particularly used engine oils.
- Wear protective clothing, including impervious gloves where practicable.
- Avoid contaminating clothes, particularly underpants, with oil.
- Do not put oily rags in pockets, the use of overalls without pockets will avoid this.
- Do not wear heavily soiled clothing and oil-impregnated foot-wear. Overalls must be cleaned regularly and kept separately from personal clothing.
- Where there is a risk of eye contact, eye protection should be worn, for example, chemical goggles or face shields; in addition an eye wash facility should be provided.
- Obtain First Aid treatment immediately for open cuts and wounds.
- Wash regularly with soap and water to ensure all oil is removed, especially before meals (skin cleansers and nail brushes will help). After cleaning, the application of preparations containing lanolin to replace the natural skin oils is advised.
- Do not use petrol, kerosine, diesel fuel, gas oil, thinners or solvents for cleaning skin.
- Use barrier creams, applying them before each work period, to help the removal of oil from the skin after work.
- If skin disorders develop, obtain medical advice without delay.

SUPPLEMENTAL RESTRAINT SYSTEM (SRS)

To improve safety, the SRS is available as optional parts. This system enhances collision safety by restraining the front occupants in case of an accident.

The SRS consists of four air bag modules, SRS air bag control unit (SRS-ECU), front and side impact sensors, SRS warning lamp and clock spring. The air bags are located in the centre of the steering wheel, above the glove box, and built into the front seat back assemblies. Each air bag has a folded air bag and an inflator unit. The SRS-ECU under the floor console monitors the system and has a safing G-sensor and an analog G-sensor. The front impact sensors are installed in the headlamp support. The side impact sensors are installed inside the center pillars or the quarter panels, inner monitor any shocks coming from the

side of the vehicle. The warning lamp on the instrument panel indicates the operational status of the SRS. The clock spring is installed in the steering column.

The SRS side air bags deploy if an impact received at the front or side of the vehicle is stronger than a certain set value, in order to protect the front seat occupant's torso in the event of a collision. Only authorized service personnel should do work on or around the SRS components. Those service personnel should read this manual carefully before starting any such work. Extreme care must be used when servicing the SRS to avoid injury to the service personnel (by inadvertent deployment of the air bags) or the driver (by rendering the SRS inoperative).

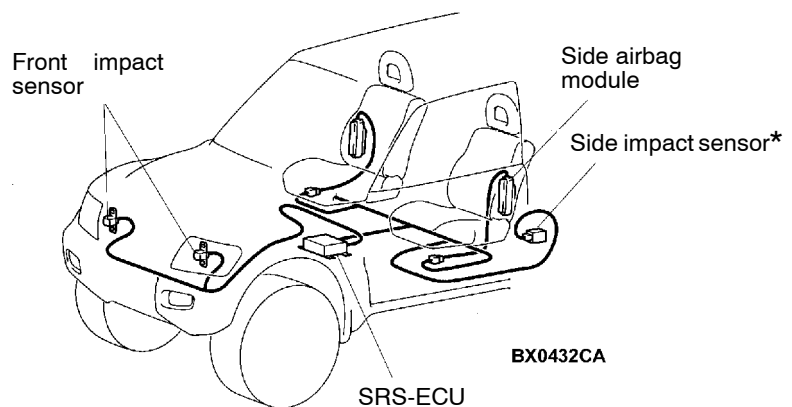
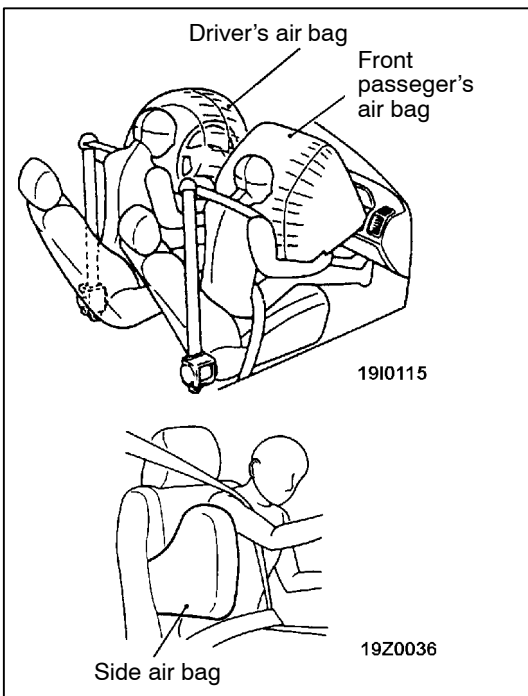
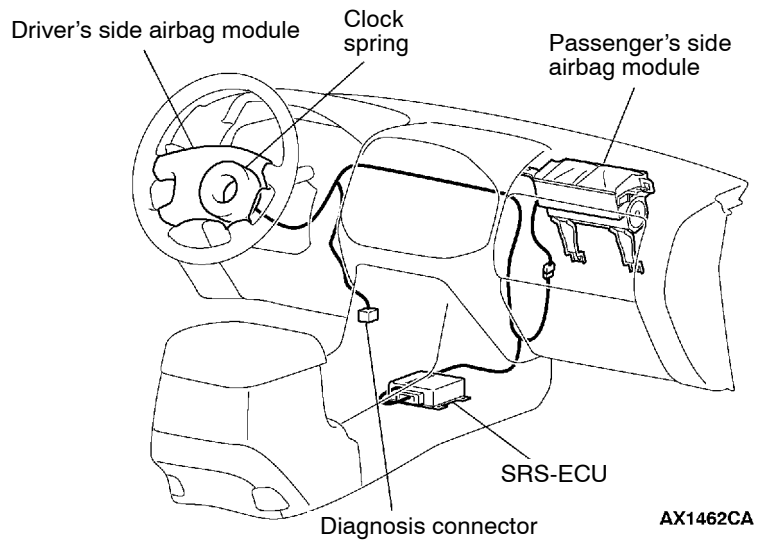
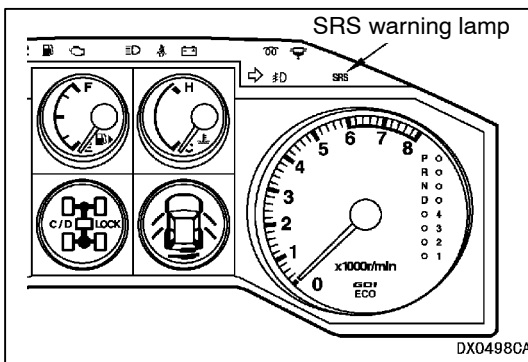

NOTE

*: Indicates the parts equipped on the right and left sides.

SRS SERVICE PRECAUTIONS

1. In order to avoid injury to yourself or others from accidental deployment of the air bag during servicing, read and carefully follow all the precautions and procedures described in this manual.
2. Do not use any electrical test equipment on or near SRS components, except those specified on GROUP 52B.
3. **Never Attempt to Repair the Following Components:**
 - SRS air bag control unit (SRS-ECU)
 - Clock spring
 - Driver's and front passenger's air bag modules
 - Side air bag modules
 - Front impact sensors
 - Side impact sensors

NOTE

If any of these components are diagnosed as faulty, they should only be replaced, in accordance with the **INDIVIDUAL COMPONENTS SERVICE** procedures in this manual. (Refer to GROUP 52B.)

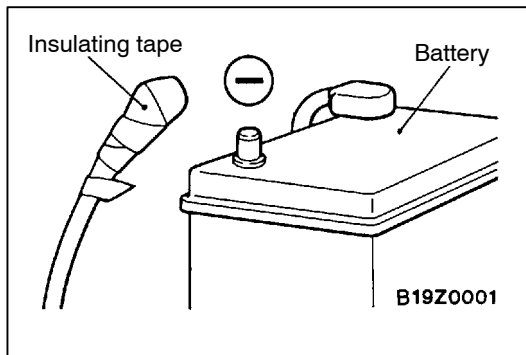

4. After disconnecting the negative (–) battery cable, wait 60 seconds at least before any service and insulate the disconnected cable with tape. The SRS retain enough voltage to deploy the air bags for a short time even after the disconnection of the battery. So, serious injury may result by accidental air bag deployment if a work is done on the SRS just after the disconnection of the battery.

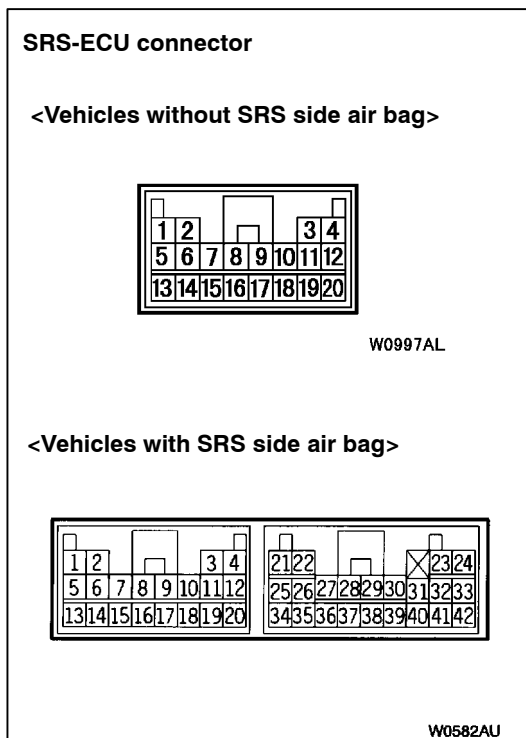

5. Do not attempt to repair the wiring harness connectors of the SRS. If the connector(s) are diagnosed as defective, replace the wiring harness(es). If the harness(es) are diagnosed as faulty, replace or repair the wiring harness(es) according to the table that follows.

SRS-ECU Terminal No.	Destination of harness	Corrective action
1, 2, 3, 4	Instrument panel wiring harness → Front wiring harness → Front impact sensor	Repair or replace each wiring harness
7	Instrument panel wiring harness → Earth	Repair or replace Instrument panel wiring harness
8	Instrument panel wiring harness → Combination meter (SRS warning lamp)	
9, 10	Instrument panel wiring harness → Front passenger's air bag module	
11, 12	Instrument panel wiring harness → Clock spring → Driver's air bag module)	Repair or replace the Instrument panel wiring harness. Replace clock spring.
13	Instrument panel wiring harness → Junction block (fuse No.8)	Repair or replace Instrument panel wiring harness.
16	Instrument panel wiring harness → Junction block (fuse No.6)	
20	Instrument panel wiring harness → Diagnosis connector	
21, 22	Side air bag wiring harness → Side air bag module (L.H.)	Repair or replace side air bag wiring harness.
23, 24	Side air bag wiring harness → Side air bag module (R.H.)	
34, 35, 36	Side air bag wiring harness → Floor wiring harness → Side impact sensor (L.H.)	Repair or each wiring harness.
40, 41, 42	Side air bag wiring harness → Floor wiring harness → Side impact sensor (R.H.)	

6. Inspection of the SRS-ECU harness connector should be carried out by the following procedure. Insert the special tool (probe, MB991222, in the harness set) into the connector from harness side (rear side), and connect the tester to this probe. If any tool than specified is used, damage to the harness and other components will result. Furthermore, measurement should not be carried out by touching the probe directly against the terminals from the front of the connector. The terminals are plated to increase their conductivity, so that if they are touched directly by the probe, the plating may break, which will cause drops in reliability.

<Vehicles without SRS side air bag>
SRS-ECU harness connector

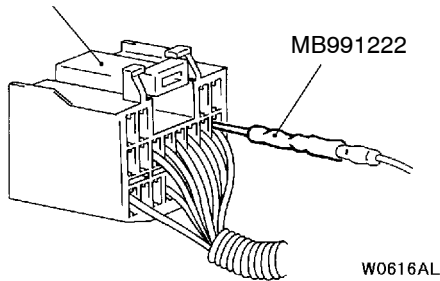

SRS-ECU harness connector (rear view)

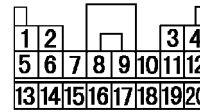

W0999AL

<Vehicles with SRS side air bag>
SRS-ECU harness connector

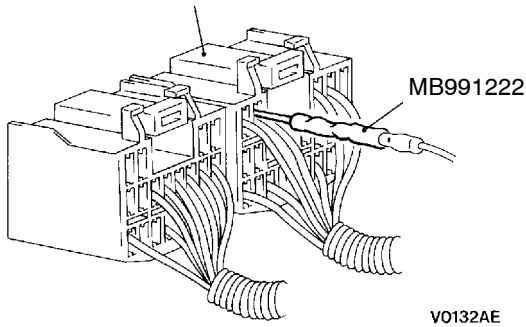

SRS-ECU harness connector (rear view)

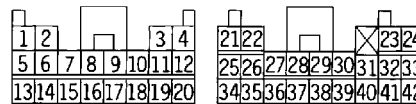

W0584AU

7. SRS components should not be subjected to temperature over 93°C, so remove the SRS-ECU, driver's and front passenger's air bag modules, clock spring, side impact sensors and front seat assemblies (side air bag modules) before drying or baking the vehicle after painting.
8. Whenever you finish servicing the SRS, check warning lamp operation to make sure that the system functions properly. (Refer to GROUP 52B.)
9. Make certain that the ignition switch is LOCK (OFF) position when the MUT-II is connected or disconnected.
10. If you have any questions about the SRS, please contact your local distributor.

NOTE

SERIOUS INJURY CAN RESULT FROM UNINTENDED AIR BAG DEPLOYMENT, SO USE ONLY THE PROCEDURES AND EQUIPMENT SPECIFIED IN THIS MANUAL.

SUPPORT LOCATIONS FOR LIFTING AND JACKING

Caution

Do not support the vehicles at locations other than specified supporting points. If do so, this will cause damage, etc.

SUPPORT POSITIONS FOR A GARAGE JACK

Caution

Never support any point other than the specified one, or it will be deformed.

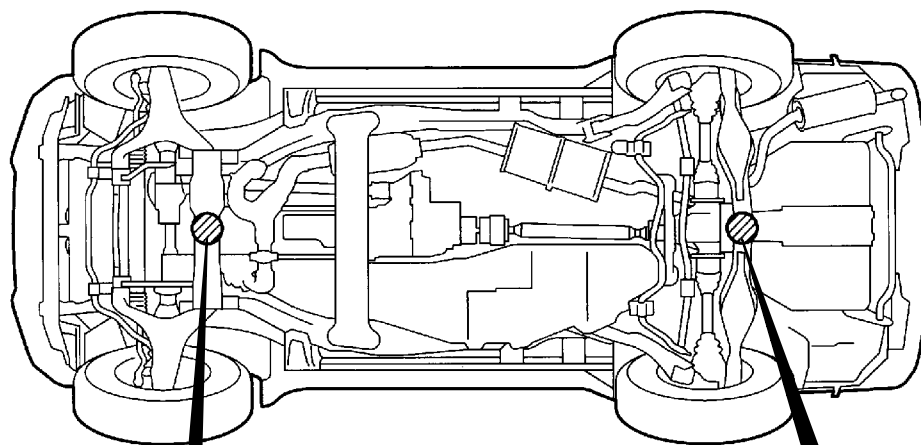

X0417CA

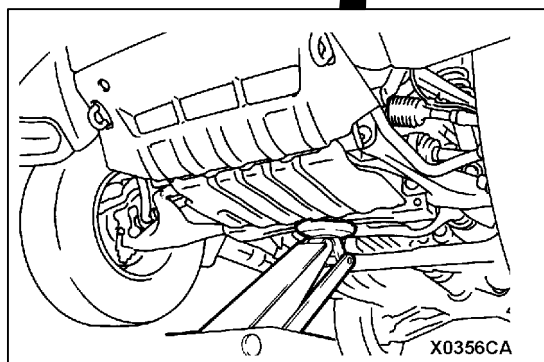

X0356CA

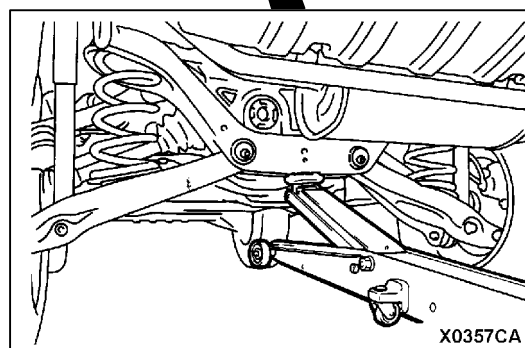

X0357CA

SUPPORT POSITIONS FOR AXLE STANDS AND A SINGLE-POST LIFT OR DOUBLE-POST LIFT

Caution

1. If rubber attachments with grooves that are too thick are used at the front support positions, the front fender may become bent, so be sure to use rubber attachments with groove thicknesses of 18 mm or less.
2. If attachments which are not high enough are used, they may damage areas such as the side step. Be sure to use attachments which are high enough, or remove the side step if not using attachments.

AXLE STANDS

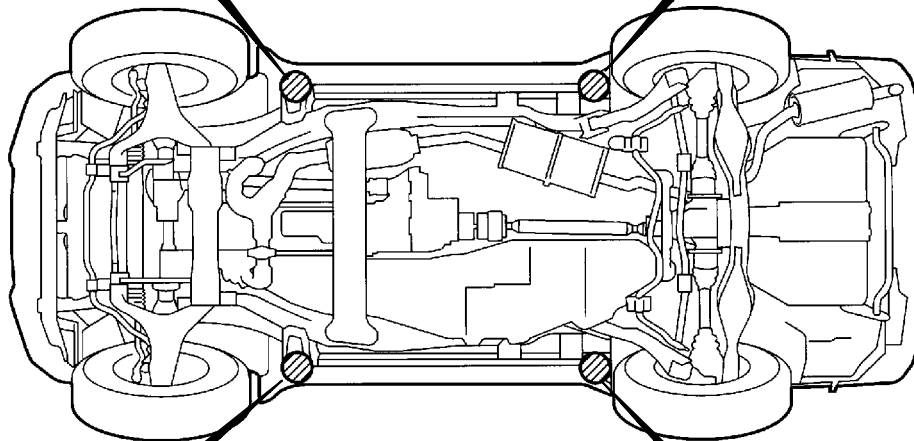
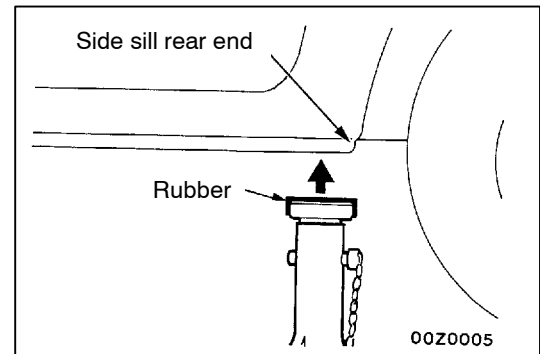
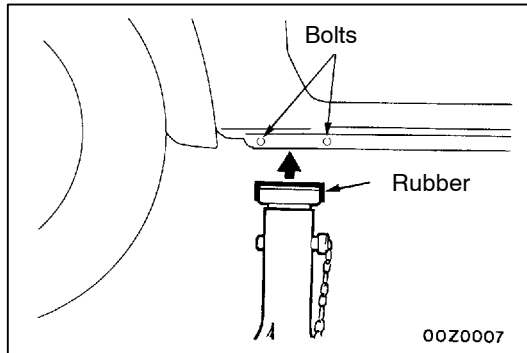

SINGLE-POST LIFT OR DOUBLE-POST LIFT

CX0418CA

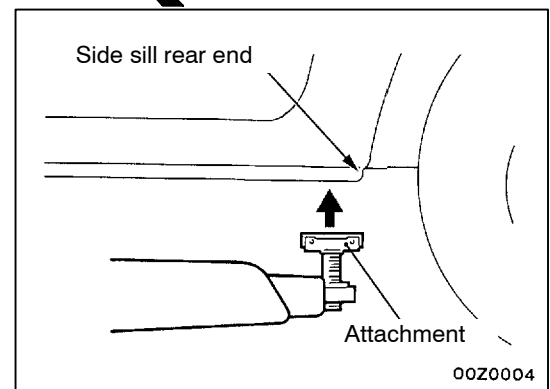
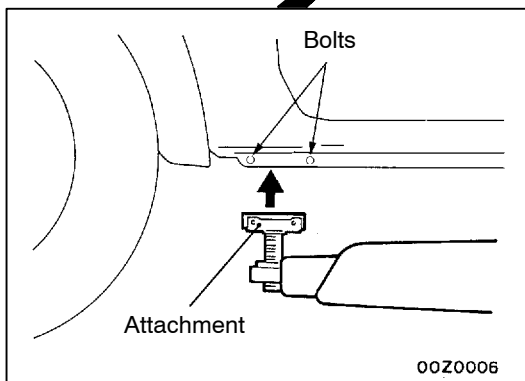

STANDARD PART/TIGHTENING-TORQUE TABLE

Each torque value in the table is a standard value for tightening under the following conditions.

- (1) Bolts, nuts and washers are all made of steel and plated with zinc.
- (2) The threads and bearing surface of bolts and nuts are all in dry condition.

The values in the table are not applicable:

- (1) If toothed washers are inserted.
- (2) If plastic parts are fastened.
- (3) If bolts are tightened to plastic or die-cast inserted nuts.
- (4) If self-tapping screws or self-locking nuts are used.

Standard bolt and nut tightening torque

Thread size		Torque N·m		
Bolt nominal diameter (mm)	Pitch (mm)	Head mark "4"	Head mark "7"	Head mark "8"
M5	0.8	2.5±0.5	5.0±1.0	6.0±1.0
M6	1.0	5.0±1.0	9.0±2.0	10±2
M8	1.25	12±2	22±4	25±4
M10	1.25	24±4	44±10	53±7
M12	1.25	41±8	83±12	98±12
M14	1.5	73±12	140±20	155±25
M16	1.5	110±20	210±30	235±35
M18	1.5	165±25	300±40	340±50
M20	1.5	225±35	410±60	480±70
M22	1.5	300±40	555±85	645±95
M24	1.5	395±55	735±105	855±125

Flange bolt and nut tightening torque

Thread size		Torque N·m		
Bolt nominal diameter (mm)	Pitch (mm)	Head mark "4"	Head mark "7"	Head mark "8"
M6	1.0	5.0±1.0	10±2	12±2
M8	1.25	13±2	24±4	27±5
M10	1.25	26±4	49±9	58±7
M10	1.5	24±4	45±8	55±10
M12	1.25	46±8	95±15	105±15
M12	1.75	43±8	83±12	98±12

NOTE

1. Be sure to use only the specified bolts and nuts, and always tighten them to the specified torques.
2. Bolts marked with indications such as 4T or 7T are reinforced bolts. The larger the number, the greater the bolt strength.

Service Bulletins

Click on the applicable bookmark to select the Service Bulletin.



SERVICE BULLETIN

TECHNICAL SERVICE PLANNING
INTERNATIONAL CAR ADMINISTRATION OFFICE. MITSUBISHI MOTORS CORPORATION

SERVICE BULLETIN		NO. : MSB-00E00-009	
		DATE : 2000-10-20	<MODEL> (EC)PAJERO/MON- TERO(V60,V70)
SUBJECT : ADDITION OF MODELS OF 2001 PAJERO/MONTERO		<M/Y> 00-10	
GROUP : GENERAL		DRAFTNO. : 00SY090209	
INFORMATION	INTERNATIONAL CAR ADMINISTRATION OFFICE	 T. MASAKI - MANAGER TECHNICAL SERVICE PLANNING	

1. Description:

On the 2001 PAJERO/MONTERO, the 4M41 engine equipped models have been added.

2. Applicable Manuals:

Manual	Pub. No.
2001 PAJERO Workshop Manual	PWJE0001 (English)
	PWJS0002 (Spanish)
2001 PAJERO CD-ROM	PWJF0003 (CD-ROM) (French)
	PWJG0004 (CD-ROM) (German)
	PWJT0008R (CD-ROM)

3. Effective Date:

From the 2001 model.

**GROUP 00
GENERAL****OUTLINE OF CHANGES**

The following models have been added for England that are equipped with the 4M41 engine.

VEHICLE IDENTIFICATION**MODELS**

<Short wheelbase>

Model code		Engine model	Transmission model	Fuel supply system
V68W	MNHFR6	4M41-DOHC Intercooler	V5M31 <5M/T>	Electronically-controlled high pressure fuel distribution
	MNHFR6	Turbo (3,200 mL)	V5A51 <5A/T>	

MAJOR SPECIFICATIONS

<Short wheelbase>

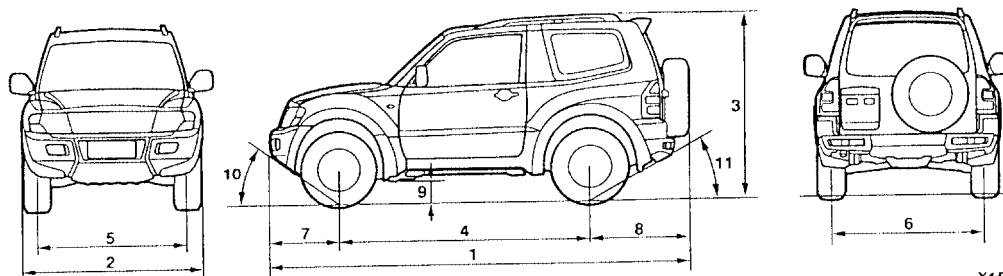

X1508CA

Items			V68W	
			MNHFR6	MYHFR6
Vehicle dimensions mm	Overall length	1	4,260	
	Overall width	2	1,845	
	Overall height (unladen)	3	1,845, 1,875*1	
	Wheelbase	4	2,545	
	Track-front	5	1,560	
	Track-rear	6	1,560	
	Overhang-front	7	710	
	Overhang-rear	8	1,000*2, 1,025*3	
	Ground clearance (unladen)	9	225	
	Angle of approach degrees	10	42°	
	Angle of departure degrees	11	33.5°	
Vehicle weight kg	Kerb weight	1,980		
	Max. gross vehicle weight	2,510		
	Max. axel weight rating-front	1,165		
	Max. axel weight rating-rear	1,345		
Seating capacity			5	
Engine	Model No.	4M41-DOHC Intercooler Turbo		
	Total displacement mL	3,200		
Transmission	Model No.	V5M31	V5A51	
	Type	5-speed manual	5-speed automatic	
Fuel system	Fuel supply system	Electronically-controlled high pressure fuel distribution		

NOTE

*1: Vehicles with roof rails

*2: Vehicles with 235/80R16 Tyre

*3: Vehicles with 265/70R16 Tyre



SERVICE BULLETIN

TECHNICAL SERVICE PLANNING
INTERNATIONAL CAR ADMINISTRATION OFFICE. MITSUBISHI MOTORS CORPORATION

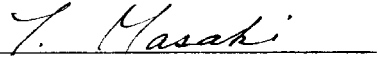
SERVICE BULLETIN		NO. : MSB-00E00-505													
		DATE : 2001 - 1 - 20	<table border="1"> <thead> <tr> <th><MODEL></th> <th><M/Y></th> </tr> </thead> <tbody> <tr> <td>(EC)PAJERO/MONTERO(V60,70)</td> <td>01 - 10</td> </tr> <tr> <td>(EC)GALANT(EA0)</td> <td>99 - 10</td> </tr> <tr> <td>(EC)SPACE RUNNER/SPACE WAGON(N60,80,90)</td> <td>98 - 10</td> </tr> <tr> <td>(EC)CARISMA</td> <td>99 - 10</td> </tr> <tr> <td>(EC)SPACE STAR(H60,70)</td> <td></td> </tr> <tr> <td>(EC)PAJERO PININ</td> <td></td> </tr> </tbody> </table>	<MODEL>	<M/Y>	(EC)PAJERO/MONTERO(V60,70)	01 - 10	(EC)GALANT(EA0)	99 - 10	(EC)SPACE RUNNER/SPACE WAGON(N60,80,90)	98 - 10	(EC)CARISMA	99 - 10	(EC)SPACE STAR(H60,70)	
<MODEL>	<M/Y>														
(EC)PAJERO/MONTERO(V60,70)	01 - 10														
(EC)GALANT(EA0)	99 - 10														
(EC)SPACE RUNNER/SPACE WAGON(N60,80,90)	98 - 10														
(EC)CARISMA	99 - 10														
(EC)SPACE STAR(H60,70)															
(EC)PAJERO PININ															
SUBJECT : ESTABLISHMENT OF GDI ENGINE IDLE LEARNING FUNCTION															
GROUP : GENERAL		DRAFTNO. : 00AL610610													
CORRECTION	INTERNATIONAL CAR ADMINISTRATION OFFICE	 T. MASAKI - MANAGER TECHNICAL SERVICE PLANNING													

1. Description:

On the GDI engine equipped cars, an idle learning function that will be required after replacement of the ECU (for engine control) or after resetting of the battery* has been established.

*: Disconnection of ECU (for engine control) battery backup power supply (disconnection of battery terminals or ECU connectors)

2. Applicable Manuals:

Manual	Pub. No.	Page	
2001 PAJERO Workshop Manual VOL.1	PWJE0001 (1/2) (English)	00-29	
	2001 MONTERO Workshop Manual VOL.1		PWJS0002 (1/2) (Spanish)
	2001 PAJERO/MONTERO Workshop Manual CD-ROM		PWJT0008R (English) (Spanish) (French) (German)
1999 GALANT Workshop Manual Supplement	PWDE9611-A (English)	00-12	
	PWDS9612-A (Spanish)		
	PWDF9613-A (French)		
	PWDG9614-A (German)		
	PWDD9615-A (Dutch)		
	PWDW9616-A (Swedish)		
1999 SPACE RUNNER/SPACE WAGON Workshop Manual	PWDE9803 (English)	00-20	
	PWDS9804 (Spanish)		
	PWDF9805 (French)		
	PWDG9806 (German)		
	PWDD9807 (Dutch)		
	PWDW9808 (Swedish)		

3. Details:

Contents of Attachment are to be added to GROUP 00 (GENERAL).

PRECAUTIONS BEFORE SERVICE

LEARNING FUNCTION OF GDI ENGINE

1. Purpose

On the GDI engine equipped cars, when replacement of the ECU (for engine control) or resetting of the battery* has been performed, an idle learning function of the ECU (for engine control) will be required.

The idle learning function will be completed by running the engine at idle by the following procedure.

NOTE:

*: Disconnection of ECU (for engine control) battery backup power supply (disconnection of battery terminals or ECU connectors)

2. Idle Learning Procedure

- (1) Start the engine, and warm up the engine until its coolant temperature reaches 85°C or higher. When the engine coolant temperature is 85°C or higher, you have only to turn the ignition switch to the ON position.
- (2) Turn the ignition switch to the LOCK (OFF) position, and stop the engine.
- (3) After lapse of ten or more seconds, restart the engine.
- (4) Run the engine at idle for ten minutes under the following conditions.
 - Transmission: Neutral (P range for automatic transmission)
 - Air conditioner and heater: Not operational
 - Engine coolant temperature: 83°C or higher
- (5) Stop the engine.
- (6) Restart the engine, and run it at idle for ten minutes under the following condition.
 - Transmission: Neutral (P range for automatic transmission)
 - Air conditioner: Operational (Temperature set at "maximum cool", fan at high speed, and windows fully opened)
 - Engine coolant temperature: 83°C or higher
- (7) Repeat steps (5) and (6).

NOTE:

- 1) When the atmospheric temperature is 20°C or more and the air conditioner has continuously been operated, step (7) may be omitted.
- 2) During idling operation of the engine in steps (4) and (6), when engine operation switches from lean operation to stoichiometric operation, engine stall can occur. In this case, clean the throttle body (throttle valve) thoroughly, and then repeat step (1) and the subsequent steps.

GROUP 00 GENERAL

OUTLINE OF CHANGES

The following models are equipped with Mitsubishi Stability Control (MITSUBISHI SC) system.

VEHICLE IDENTIFICATION

MODELS

<Short wheelbase>

Model code		Engine model	Transmission model	Fuel supply system
V68W	MNDFL6	4M41-DOHC Intercooler Turbo (3,200 mL)	V5M31 <5M/T>	Electronically-controlled high pressure fuel distribution
	MNHFL6			
	MNHFR6			
	MYHFL6		V5A51 <5A/T>	
	MYHFR6			
	MNXFL6		V5M31 <5M/T>	
	MNXFR6			
	MYXFL6		V5A51 <5A/T>	
	MYXFR6			
V65W	MNHCL6	6G74GDI (3,496 mL)	V5M31 <5M/T>	GDI
	MNHCR6			
	MYHCL6		V5A51 <5A/T>	
	MYHCR6			
	MNXCL6		V5M31 <5M/T>	
	MNXCR6			
	MYXCL6		V5A51 <5A/T>	
	MYXCR6			

<Long wheelbase>

Model code		Engine model	Transmission model	Fuel supply system
V78W	LNDFL6	4M41-DOHC Intercooler Turbo (3,200 mL)	V5M31 <5M/T>	Electronically-controlled high pressure fuel distribution
	LNHF6L6			
	LNHF6R6			
	LYHF6L6		V5A51 <5A/T>	
	LYHF6R6			
	LNXF6L6		V5M31 <5M/T>	
	LNXF6R6			
	LYXF6L6		V5A51 <5A/T>	
	LYXF6R6			
V75W	LNHCL6	6G74GDI (3,496 mL)	V5M31 <5M/T>	GDI
	LNHCR6			
	LYHCL6		V5A51 <5A/T>	
	LYHCR6			
	LNXC6L6		V5M31 <5M/T>	
	LNXC6R6			
	LYXC6L6		V5A51 <5A/T>	
	LYXC6R6			

GROUP 00

GENERAL

INSPECTION SERVICE POINTS

DIAGNOSIS FUNCTION

WHEN USING THE WARNING LAMP

The diagnosis code read-out function, which is available by means of the neutral position indicator lamp, has been discontinued <Vehicles with 6G74 GDI>.

VEHICLE IDENTIFICATION

MODELS

<Short wheelbase>

Model code	Engine model	Transmission model	Fuel supply system
V64W	4D56 Intercooler Turbo (2,477 mL)	V5MT1 <5M/T>	Injection
		V5M31 <5M/T>	
V68W	4M41-DOHC Intercool- er Turbo (3,200 mL)	V5M31 <5M/T>	Electronically-con- trolled high pressure fuel distribution
		V5A51 <5A/T>	
		V5M31 <5M/T>	
		V5A51 <5A/T>	
V65W	6G74 GDI (3,496 mL)	V5A51 <5A/T>	GDI
		V5M31 <5M/T>	
		V5A51 <5A/T>	

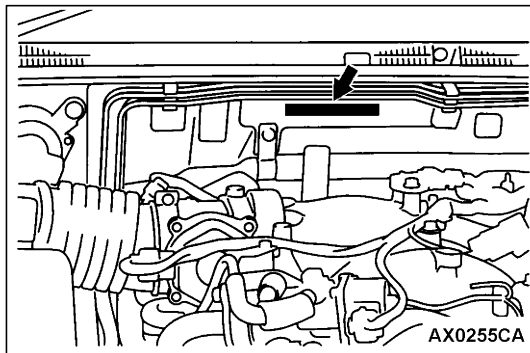

<Long wheelbase>

Model code		Engine model	Transmission model	Fuel supply system
V74W	LNDFL6	4D56 Intercooler Turbo (2,477 mL)	V5MT1 <5M/T>	Injection
	LNHFL6		V5M31 <5M/T>	
	LNXFL6			
V78W	LNDFL6	4M41-DOHC Intercool- er Turbo (3,200 mL)	V5M31 <5M/T>	Electronically-con- trolled high pressure fuel distribution
	LNHFL6			
	LNHFR6			
	LYHFL6		V5A51 <5A/T>	
	LYHFR6			
	LNXFL6		V5M31 <5M/T>	
	LNXFR6			
	LYXFL6		V5A51 <5A/T>	
	LYXFR6			
V75W	LYHCL6	6G74 GDI (3,496 mL)	V5A51 <5A/T>	GDI
	LYHCR6			
	LNXCL6		V5M31 <5M/T>	
	LYXCL6		V5A51 <5A/T>	
	LYXCR6			



CHASSIS NUMBER

The chassis number is stamped on the toeboard inside the engine compartment.

J M B M N V6 4 W 2 J 000001

 1 2 3 4 5 6 7 8 9 10 11

AX1428CA

No.	Items		Contents
1	Fixed figure	J	Asia
2	Distribution channel	M	Japan channel
3	Destination	A	For Europe, right hand drive
		B	For Europe, left hand drive
4	Body style	M	3-door
		L	5-door
5	Transmission type	N	5-speed manual transmission
		Y	5-speed automatic transmission
6	Development order	V6	MITSUBISHI PAJERO short wheelbase
		V7	MITSUBISHI PAJERO long wheelbase
7	Engine	4	4D56: 2,477 mL diesel engine
		5	6G74: 3,496 mL petrol engine
		8	4M41: 3,200 mL diesel engine
8	Sort	W	Station wagon
9	Model year	2*	2002
10	Plant	J	Pajero Manufacturing Co., Ltd. *
11	Serial number	-	-

NOTE

*: Indicates changes.

MAJOR SPECIFICATIONS

The items other than listed below are the same as before.

<Short wheelbase>

Items		V64W		
		MNDFL6	MNHFL6, MNHFR6	MNXFL6, MNXFR6
Vehicle weight kg	Kerb weight	1,875	1,910	1,930
	Max. gross vehicle weight	2,510		
	Max. axle weight rating-front	1,200		
	Max. axle weight rating-rear	1,600		

<Long wheelbase>

Items		V74W		
		LNDFL6	LNHFL6	LNDFL6
Vehicle weight kg	Kerb weight	2,025	2,065	2,100
	Max. gross vehicle weight	2,760		
	Max. axle weight rating-front	1,200		
	Max. axle weight rating-rear	1,650		

Items		V78W				
		LNDFL6	LNHFL6, LNHFR6	LYHFL6, LYHFR6	LNDFL6, LNDFR6	LYXFL6, LYXFR6
Vehicle weight kg	Max. gross vehicle weight	2,810				
	Max. axle weight rating-front	1,200				
	Max. axle weight rating-rear	1,650				

PRECAUTIONS BEFORE SERVICE

SUPPLEMENTAL RESTRAINT SYSTEM (SRS), SEAT BELT WITH PRE-TENSIONER

1. Items to follow when servicing SRS
 - (1) Be sure to read GROUP 52B - Supplemental Restraint System (SRS).
For safe operations, please follow the directions and heed all warnings.
 - (2) Wait at least 60 seconds after disconnecting the battery cable before doing any further work.
The SRS system is designed to retain enough voltage to deploy the air bag even after the battery has been disconnected. Serious injury may result from unintended air bag deployment if work is done on the SRS system immediately after the battery cable is disconnected.
 - (3) Warning labels must be heeded when servicing or handling SRS components and seat belt with pre-tensioner. Warning labels are located in the following locations.
 - Hood
 - Sun visor
 - Glove box
 - SRS-ECU
 - Steering wheel
 - Steering gearbox
 - Air bag module (driver's side and front passenger's side)
 - Front impact sensor
 - Clock spring
 - Seat belt with pre-tensioner
 - Side air bag module
 - Side impact sensor
 - (4) Always use the designated special tools and test equipment.
 - (5) Store components removed from the SRS and seat belt with pre-tensioner in a clean and dry place.
The air bag module and seat belt with pre-tensioner should be stored on a flat surface and placed so that the pad surface is facing upward.
Do not place anything on top of it.
 - (6) Never attempt to disassemble or repair the SRS components (SRS-ECU, air bag module, clock spring and side impact sensor) and seat belt with pre-tensioner.
 - (7) Whenever you finish servicing the SRS and seat belt with pre-tensioner, check the SRS warning lamp operation to make sure that the system functions properly.
 - (8) Be sure to deploy the air bag and seat belt with pre-tensioner before disposing of the air bag module and seat belt with pre-tensioner or disposing of a vehicle equipped with an air bag and seat belt with pre-tensioner. (Refer to GROUP 52B - Air Bag Module and Seat Belt with Pre-tensioner Disposal Procedures.)
2. Observe the following when carrying out operations on places where SRS components and seat belt with pre-tensioner are installed, including operations not directly related to the SRS air bag and seat belt with pre-tensioner.
 - (1) When removing or installing parts do not allow any impact or shock to the SRS components and seat belt with pre-tensioner.
 - (2) SRS components and seat belt with pre-tensioner should not be subjected to heat, so remove the SRS components and seat belt with pre-tensioner before drying or baking the vehicle after painting.
 - SRS-ECU, air bag module, clock spring, front and side impact sensors: 93°C or more
 - Seat belt with pre-tensioner: 90°C or moreAfter re-installing them, check the SRS warning lamp operation to make sure that the system functions properly.

NOTES

ENGINE <6G7>

Click on the applicable bookmark to selected the required model year.

ENGINE <6G7>

CONTENTS

GENERAL INFORMATION	3	Compression Pressure Check	9
SERVICE SPECIFICATIONS	3	Intake Manifold Vacuum Check	10
SEALANT	4	Lash Adjuster Check	10
SPECIAL TOOLS	4	OIL PAN AND OIL SCREEN	13
ON-VEHICLE SERVICE	6	TIMING BELT	15
Drive Belt Tension Check and Adjustment	6	CRANKSHAFT OIL SEAL	23
Auto-tensioner Check	6	CAMSHAFT OIL SEAL	25
Ignition Timing Check	6	CYLINDER HEAD GASKET	27
Idle Speed Check	7	ENGINE ASSEMBLY	30
Idle Mixture Check	8		

GENERAL INFORMATION

Items		6G74-GDI	
Total displacement ml		3,497	
Bore × Stroke mm		93 × 85.8	
Compression ratio		10.4	
Combustion chamber		Pentroof + ball-in-piston	
Camshaft arrangement		DOHC	
Number of valve	Intake	12	
	Exhaust	12	
Valve timing	Intake	Opening	BTDC 8°
		Closing	ABDC 56°
	Exhaust	Opening	BBDC 48°
		Closing	ATDC 16°
Fuel system		Electronically controlled multipoint fuel injection	
Rocker arm		Roller type	
Auto-lash adjuster		Equipped	

SERVICE SPECIFICATIONS

Items	Standard value	Limit
Basic ignition timing	5° BTDC ± 3°	-
Ignition timing	Approx. 20° BTDC*1	-
Idle speed r/min	600 ± 100*1	-
CO contents %	0.5 or less	-
HC contents ppm	100 or less	-
Compression pressure (at engine speed of 280 r/min) kPa	1,275	980
Compression pressure difference of all cylinders kPa	-	Max. 98
Intake manifold vacuum kPa	-	Min. 56*2
Auto tensioner rod depth (mm)	Within 1	-
Timing belt tension torque N·m	4.4	-
Auto-tensioner rod protrusion amount mm	3.8 - 5.0	-

NOTE



*1: Indicates the value measured within 4 minutes since the engine was started.

*2: Indicates the value when more than 4 minutes have passed since the engine was started.

SEALANT

Items	Specified sealants	Remarks
Oil pan	MITSUBISHI GENUINE PART MD970389 or equivalent	Semi-drying sealant

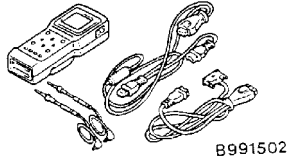
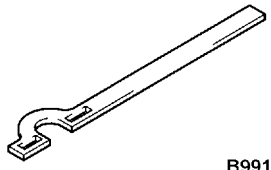
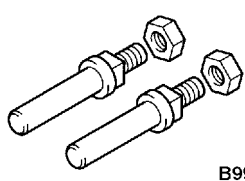
SPECIAL TOOLS

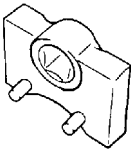
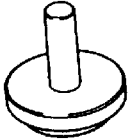
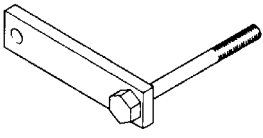
Tool	Number	Name	Use
 B991502	MB991502	MUT-II sub assembly	<ul style="list-style-type: none"> • Checking the ignition timing • Checking the idle speed • Erasing diagnosis code
 B991800	MB991800	Pulley holder	Supporting of crankshaft pulley
 B991802	MB991802	Pin B	
	MD998769	Crankshaft pulley spacer	Operating the crankshaft when installing the timing belt
	MD998767	Tension pulley socket wrench	Timing belt tension adjustment
	MD998718	Crankshaft rear oil seal installer	Press-fitting the crankshaft rear oil seal
	MD998781	Flywheel stopper	Securing the flywheel

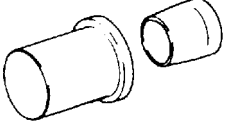
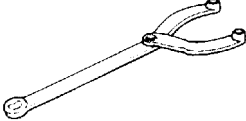
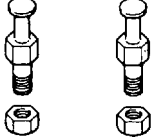
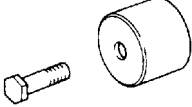
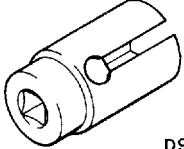
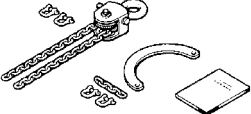
Tool	Number	Name	Use
	MD998717	Crankshaft front oil seal installer	Press-in of the crankshaft front oil seal
	MB990767	End yoke holder	Supporting of camshaft sprocket
	MD998719	Crankshaft pulley holder pin	
	MD998761	Camshaft oil seal installer	Press-in of the camshaft oil seal
 <p data-bbox="331 1115 415 1136">D998773</p>	MD998773	Detonation sensor wrench	Detonation sensor removal and installation
 <p data-bbox="337 1310 399 1331">B991683</p>	MB991683	Sling chain set	Removal and installation of engine assembly

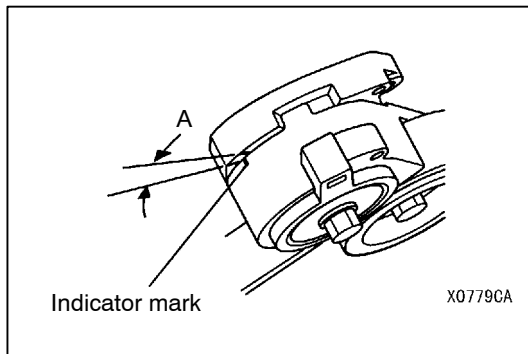

ON-VEHICLE SERVICE

DRIVE BELT TENSION CHECK AND ADJUSTMENT

Caution

Perform the check after rotating the engine to the normal direction (one revolution and over).

1. Check that the indicator mark of the auto-tensioner is located within the scope shown as "A" on the tensioner bracket.
2. If the mark is located out of the scope "A," replace the drive belt.

NOTE

Since the auto-tensioner is used, it is not necessary to adjust the tension of the belt.

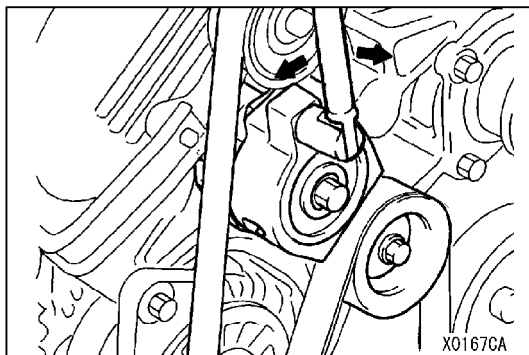

AUTO-TENSIONER CHECK

1. Run the engine at idling speed and then stop it to check whether the drive belt is forced out from the width of the auto-tensioner pulley.
2. Remove the drive belt. (Refer P.11A-17.)
3. Move the auto-tensioner right and left by using a 12.7 mm spinner handle and the like to check whether there is no catch.
4. If some abnormality is found during the above mentioned check (1) and (3), replace the auto-tensioner.
5. Install the drive belt. (Refer P.11A-18.)

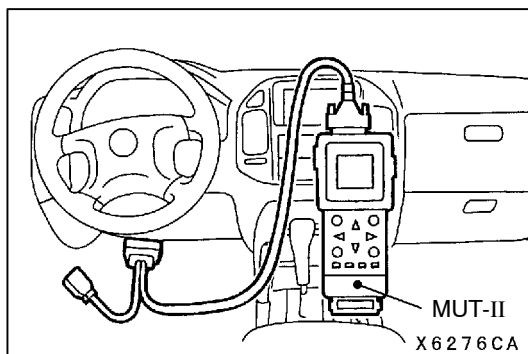

IGNITION TIMING CHECK

1. Before inspection, set the vehicle to the pre-inspection condition.
2. Turn the ignition switch to the LOCK (OFF) position, and then connect the MUT-II to the diagnosis connector.

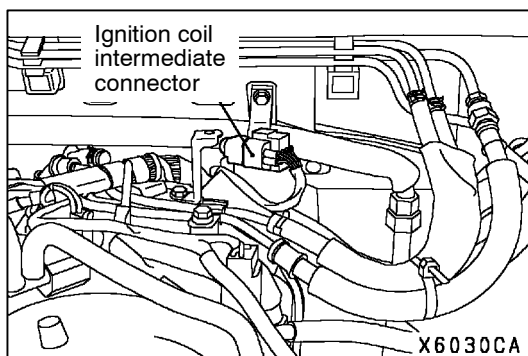

3. Set a timing light to the ignition coil power supply line (intermediate connector No. 7 terminal) of the ignition coil intermediate connector engine-side harness.
4. Start the engine and let it run at idle.
5. Use the MUT-II to measure engine idle speed and check that it is within the standard value.

Standard value: 600 ± 100 (700 ± 100)*

NOTE

*: Indicates the values when more than 4 minutes have passed since the idling condition was started.

6. Select No.17 of the MUT-II Actuator test.

NOTE

At this time, the engine speed will become approximately 700 r/min.

7. Check that basic ignition timing is within the standard value.

Standard value: 5° BTDC $\pm 3^{\circ}$

8. If the basic ignition timing is outside the standard value, inspect the GDI system while referring to GROUP 13A - Troubleshooting.
9. Press the MUT-II clear key (Select a forced driving cancel mode) to release the Actuator test.

Caution

If the test is not cancelled, a forced driving will continue for 27 minutes. Driving under this condition may damage the engine.

10. Check that ignition timing is at the standard value.

**Standard value: approx. 20° BTDC (AT)
approx. 13° BTDC (MT)**

NOTE

- (1) The ignition timing will become approximately 5° BTDC after more than 4 minutes have passed since the basic ignition timing set mode was released.
 - (2) The ignition timing may fluctuate within $\pm 7^{\circ}$ BTDC. This is normal.
 - (3) In higher altitude, the ignition timing is more advanced than the standard value by approximately 5 degree.
11. Remove the timing light.
 12. Turn the ignition switch to the lock (OFF) position, and then disconnect the MUT-II.

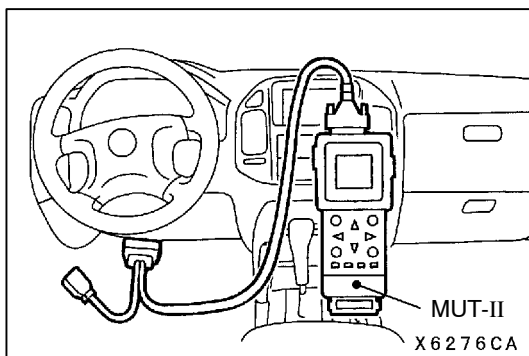

IDLE SPEED CHECK

1. Before inspection, set the vehicle to the pre-inspection condition.
2. Turn the ignition switch to the lock (OFF) position, and then connect the MUT-II to the diagnosis connector.
3. Check the basic ignition timing.

NOTE

Refer to P.11A-6 concerning the check procedure of the basic ignition timing.

Standard value: 5° BTDC $\pm 3^{\circ}$

4. Check the idle speed. Select item No. 22 and take a reading of the idle speed.

Standard value: 600 ± 100 (700 ± 100)*

NOTE

- (1) *: Indicates the values when more than 4 minutes have passed since the idling condition was started.
- (2) The idle speed is controlled automatically by the idle speed control system.

5. If the idle speed is outside the standard value, inspect the GDI components by referring to GROUP 13A - Troubleshooting.

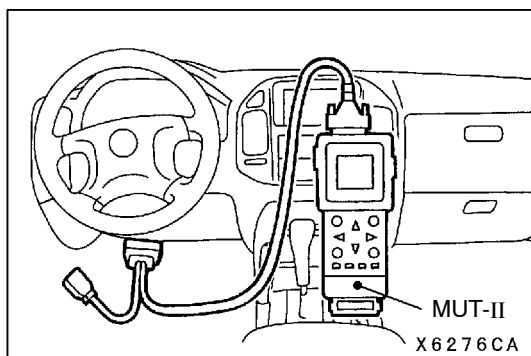

IDLE MIXTURE CHECK

1. Before inspection, set the vehicle to the pre-inspection condition.
2. Turn the ignition switch to the lock (OFF) position, and then connect the MUT-II to the diagnosis connector.
3. Check that the basic ignition timing is within the standard value.

NOTE

Refer to P.11A-6 concerning the check procedure of the basic ignition timing.

Standard value: 5° BTDC ± 3°

4. Run the engine at 2,500 r/min for 2 minutes.
5. Set the CO, HC tester.
6. Check the CO contents and the HC contents at idle.

NOTE

This measurement should be performed in less than approximately 4 minutes since the engine speed become the idle speed.

Standard value

CO contents: 0.5% or less

HC contents: 100 ppm or less

7. If there is a deviation from the standard value, check the following items:
 - Diagnosis output
 - Fuel pressure
 - Injector
 - Ignition coil, spark plug
 - EGR control system
 - Evaporative emission control system
 - Compression pressure

NOTE

Replace the three way catalyst when the CO and HC contents are not within the standard value, even though the result of the inspection is normal on all items.

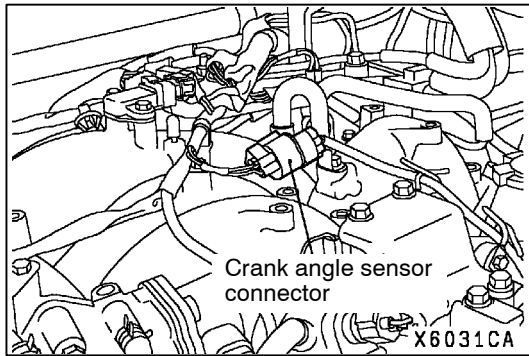

COMPRESSION PRESSURE CHECK

1. Before inspection, check that the engine oil, starter and battery are normal. In addition, set the vehicle to the pre-inspection condition.
2. Remove all of the ignition coils and spark plugs.
3. Disconnect the crank angle sensor connector.

NOTE

Doing this will prevent the engine-A/T-ECU from carrying out ignition and fuel injection.

4. Cover the spark plug hole with a shop towel etc., and after the engine has been cranked, check that no foreign material is adhering to the shop towel.

Caution

- (1) **Keep away from the spark plug hole when cranking.**
 - (2) **If compression is measured with water, oil, fuel, etc., that has come from cracks inside the cylinder, these materials will become heated and will gush out from the spark plug hole, which is dangerous.**
5. Set compression gauge to one of the spark plug holes.
 6. Crank the engine with the throttle valve fully open and measure the compression pressure.

Standard value (at engine speed of 280 r/min):

1,275 kPa

Limit (at engine speed of 280 r/min):

Min. 980 kPa

7. Measure the compression pressure for all the cylinders, and check that the pressure differences of the cylinders are below the limit.

Limit: Max. 98 kPa

8. If there is a cylinder with compression or a compression difference that is outside the limit, pour a small amount of engine oil through the spark plug hole, and repeat the operations in steps 6 and 7.
 - (1) If the compression increases after oil is added, the cause of the malfunction is a worn or damaged piston ring and/or cylinder inner surface.
 - (2) If the compression does not rise after oil is added, the cause is a burnt or defective valve seat, or pressure is leaking from the gasket.
9. Connect the crank angle sensor connector.
10. Install the spark plugs and ignition coils.
11. Use the MUT-II to erase the diagnosis codes.

NOTE

This will erase the diagnosis code resulting from the crank angle sensor connector being disconnected.

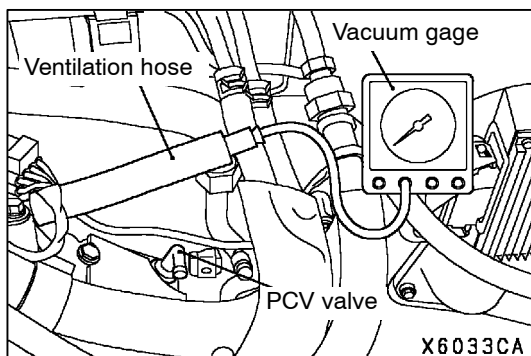
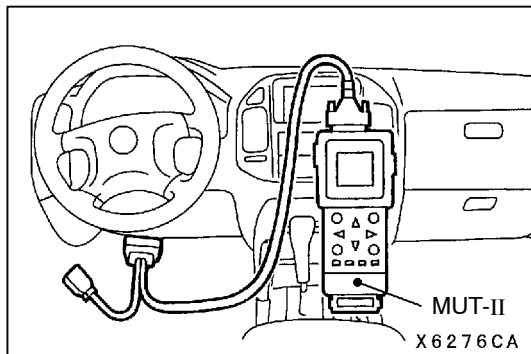

INTAKE MANIFOLD VACUUM CHECK

1. Before inspection, set the vehicle to the pre-inspection condition.
2. Turn the ignition switch to the LOCK (OFF) position.
3. Connect the diagnosis connector to the MUT-II.
4. Remove the ventilation hose from the PCV valve, connect the ventilation hose to a vacuum gauge, and then plug the PCV valve.
5. Start the engine, and let it run at idle.
6. Keep the engine run at idle for at least 4 minutes. The idle speed should be 700 r/min.
7. Check the intake manifold vacuum.

Limit: Min. 60 kPa

8. Turn the ignition switch to the LOCK (OFF) position.
9. Remove the vacuum gauge, and return the ventilation hose to its normal condition.
10. Remove the MUT-II.

LASH ADJUSTER CHECK

If an abnormal noise (knocking) that seems to be coming from the lash adjuster is heard after starting the engine and does not stop, carry out the following check.

NOTE

- (1) If the vehicle is parked on a slope for a long period of time, the amount of oil inside the lash adjuster will decrease, and air may get into the high pressure chamber when starting the engine.
- (2) After parking the vehicle for long periods, the oil drains out of the oil passage, and it takes time for the oil to be supplied to the lash adjuster, so air can get into the high pressure chamber.
- (3) If either of the above situations occur, the abnormal noise can be eliminated by bleeding the air from inside the lash adjusters.
- (4) The abnormal noise, which is caused by a defective lash adjuster, occurs immediately after the engine start and changes in accordance with the engine speed, but not the engine load.
- (5) If there is a problem with the lash adjusters, the noise will almost never disappear, even if the engine has been run at idle to let it warm up.

The only case where the noise might disappear is if the oil in the engine has not been looked after properly and oil sludge has caused the lash adjusters to stick.

FUNCTIONAL TEST

1. Start the engine.
2. Check that the noise occurs immediately after the engine is started, and that the noise changes in accordance with changes in the engine speed.
If the noise does not occur immediately after the engine is started, or if it does not change in accordance with the engine speed, the problem is not being caused by the lash adjusters, so check for some other cause of the problem. Moreover, if the noise does not change in accordance with the engine speed, the cause of the problem is probably not with the engine. (In these cases, the lash adjusters are normal.)
3. While the engine is idling, check that the noise level does not change when the engine load is varied (for example, by shifting from N → D).
If the noise level changes, the cause of the noise is probably parts striking because of worn crankshaft bearings or connecting rod bearings. (In such cases, the lash adjusters are normal.)
4. After the engine has warmed up, run it at idle and check if any noise can be heard.
If the noise has become smaller or disappeared, oil sludge could make the lash adjusters stick. Clean the lash adjusters. (Refer to the Engine Workshop Manual.) If not improved, go to step 5.
5. Bleed air from the lash adjusters. (Refer to P.11A-11.)
6. If the noise has not disappeared even after the air bleeding, clean the lash adjusters. (Refer to the Engine Workshop Manual.)

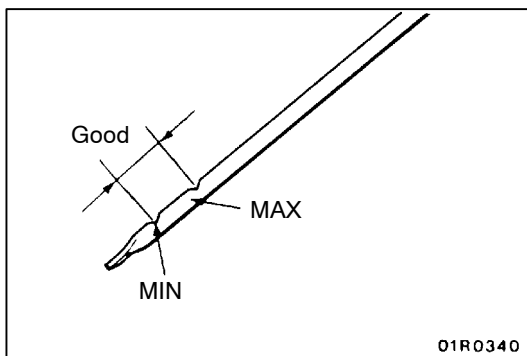
**LASH ADJUSTER AIR BLEEDING**

1. Check the engine oil and replenish or replace the oil if necessary.

NOTE

- (1) If there is a only small amount of oil, air will be drawn in through the oil screen and will get into the oil passage.
- (2) If the amount of oil is greater than normal, then the oil will being mixed by the crankshaft and a large amount of air may get mixed into the oil.
- (3) If the oil is degenerated, air and oil will not separate easily in oil, and the amount of air mixed into the oil will increase.

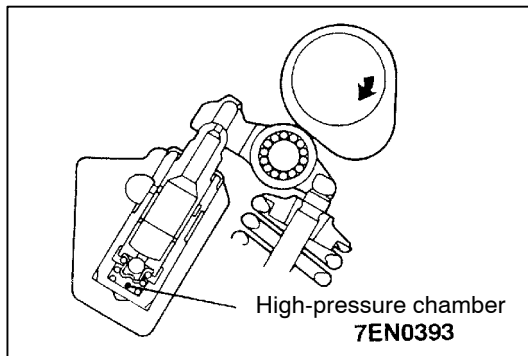

If the air which has been mixed in with the oil due to any of the above reasons gets into the high pressure chamber of the lash adjuster, the air inside the high pressure chamber will be compressed when the valve is open and the lash adjuster will over-compress, resulting in abnormal noise when the valve closes.

This is the same effect as if the valve clearance is adjusted to be too large by mistake. If the air inside the lash adjusters is then released, the operation of the lash adjusters will return to normal.

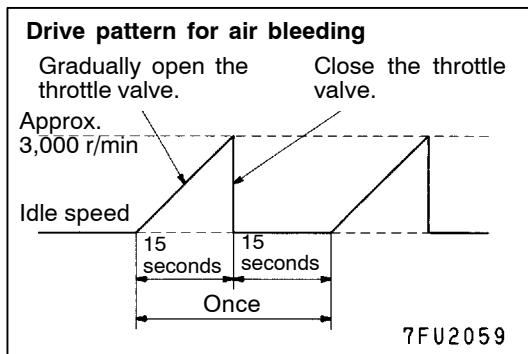

2. Run the engine at idle for 1 - 3 minutes to let it warm up.
3. With no load on the engine, repeat the drive pattern shown in the illustration at left and check if the abnormal noise disappears. (The noise should normally disappear after 10 - 30 repetitions, but if there is no change in the noise level after 30 repetitions or more, the problem is probably not due to air inside the lash adjusters.)
4. After the noise has disappeared, repeat the drive pattern shown in the illustration at left a further 5 times.
5. Run the engine at idle for 1 - 3 minutes and check that the noise has disappeared.

OIL PAN AND OIL SCREEN

REMOVAL AND INSTALLATION

Pre-removal and Post-installation Operation

- Skid Plate and Under Cover Removal and Installation
- Engine Oil Draining and Refilling (Refer to GROUP 12 - On-vehicle Service.)
- Starter Assembly Removal and Installation (Refer to GROUP 16 - Starting System.)

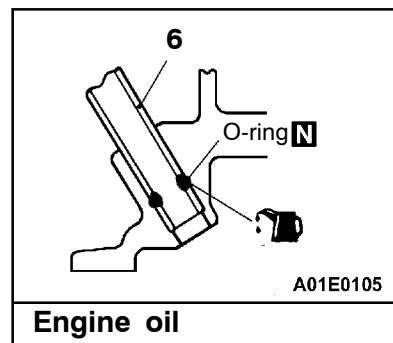
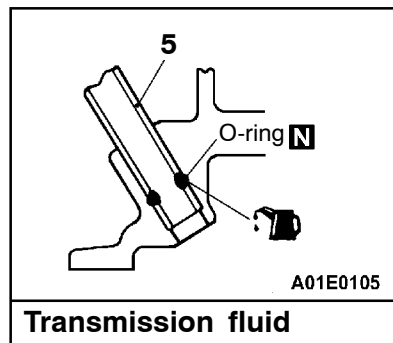
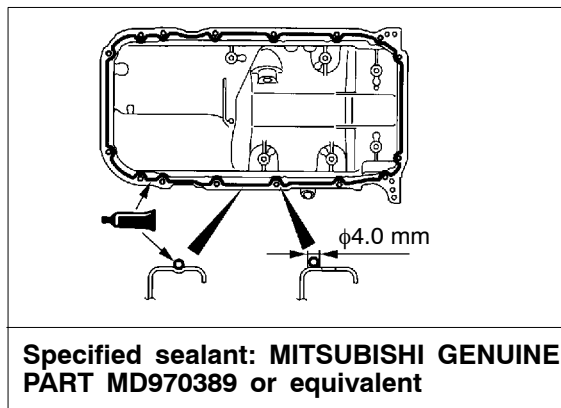
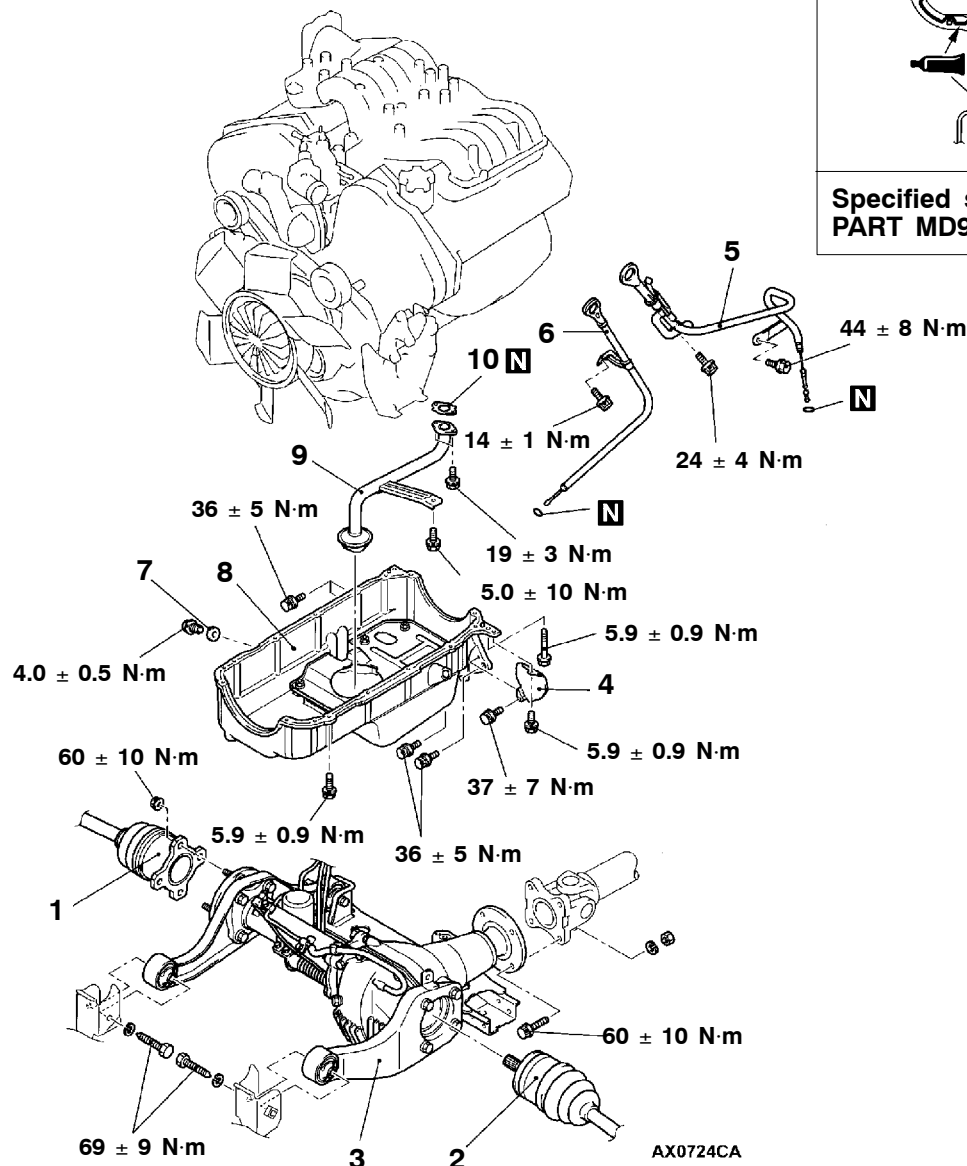

Removal steps

1. Drive shaft <R.H.>
2. Drive shaft <L.H.>
3. Front differential, No.2 crossmember
4. Cover
5. A/T oil dipstick assembly



6. Engine dipstick assembly
7. Gasket
8. Oil pan
9. Oil screen
10. Gasket

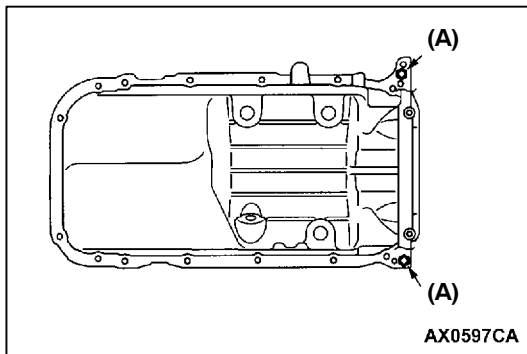

REMOVAL SERVICE POINT

◀A▶ OIL PAN REMOVAL

1. Remove the oil pan installation bolts.

Caution

The use of an oil pan remover (MD998727) can damage the oil pan (aluminum made).

2. Screw the bolts (M10) securing the oil pan to the transmission assembly in the illustrated bolt holes, then remove the oil pan.

INSTALLATION SERVICE POINTS

▶A◀ OIL PAN INSTALLATION

1. Remove sealant from the oil pan and cylinder block mating surfaces.
2. Degrease the sealant-coated surface and the engine mating surface.
3. Apply MITSUBISHI genuine part number MD970389 or equivalent around the gasket surface of oil pan as specified in the illustration.

NOTE

The sealant should be applied in a continuous bead approximately 4.0 mm in diameter.

4. Assemble the oil pan to the cylinder block within 30 minutes after applying the sealant.

Caution

The bolt holes for bolts 13 and 14 in the illustration are cut away on the transmission side. Be careful not to insert these bolts at an angle.

5. Tighten the bolts in order of the numbers shown in the illustration.

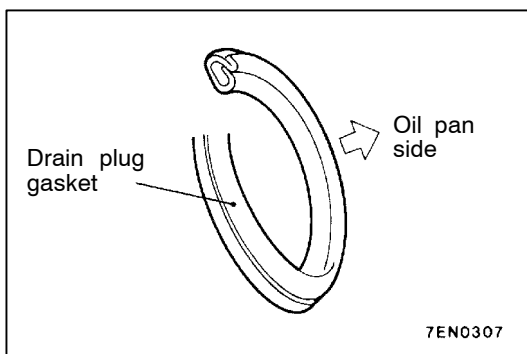
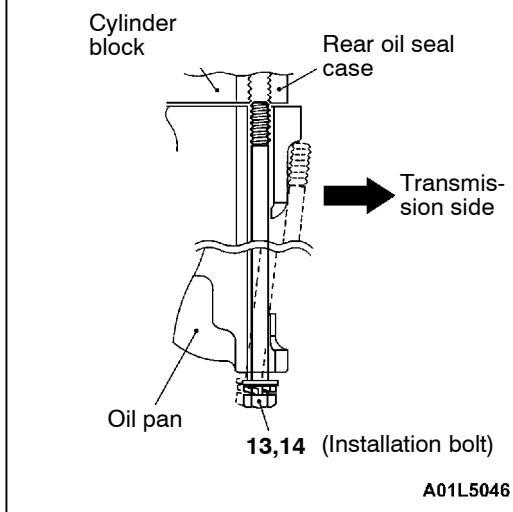
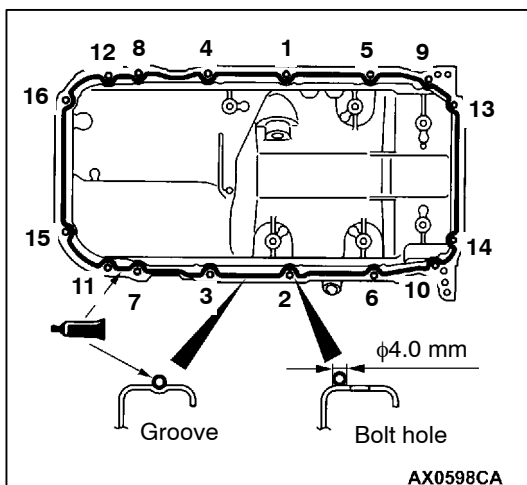

▶B◀ DRAIN PLUG GASKET INSTALLATION

Replace the gasket with a new gasket. Install the new gasket in the direction shown in the illustration.

INSPECTION

- Check the oil pan for cracks.
- Check the oil pan sealant-coated surface for damage and deformation.
- Check the oil screen for cracked, clogged or damaged wire net and pipe.

TIMING BELT

REMOVAL AND INSTALLATION

Pre-removal Operation

- Skid Plate and Under Cover Removal and Installation
- Battery abd batterytray Removal and Installation
- Air cleaner assembly Removal and Installation (Refer to GROUP 15)
- Shroud assembly Removal and Installation (Refer to GROUP 14 - Cooling Fan.)
- Engine Coolant Draining and Refilling (Refer to GROUP 14 - On-vehicle Service.)

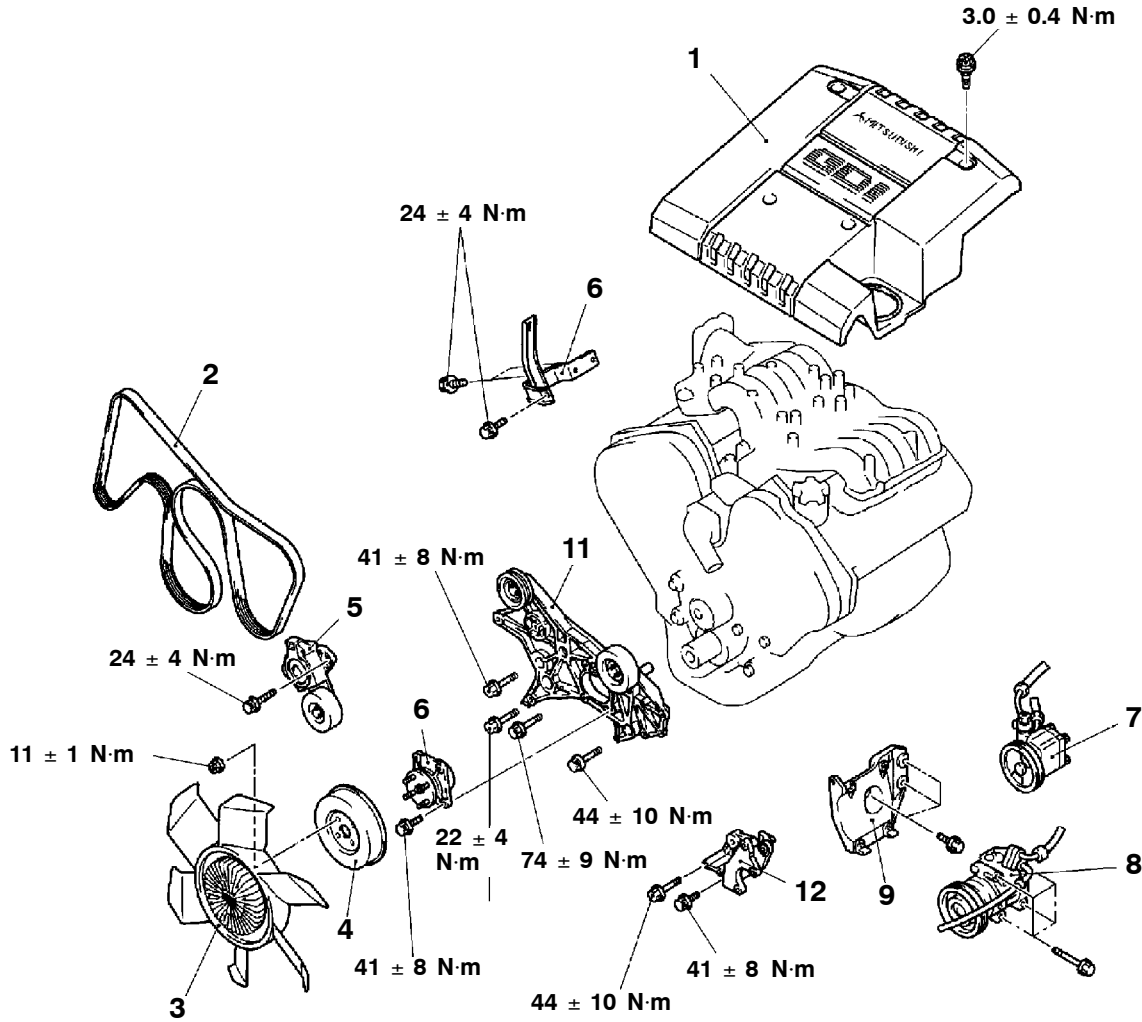

AXD131CA

Removal steps

- | | | | |
|---------------------------|--|-----------------------|---|
| <p>▶F◀</p> <p>◀A▶ ▶E▶</p> | <p>1. Cover</p> <p>2. Drive belt</p> <p>3. Cooling fan and fan clutch assembly</p> <p>4. Cooling fan pulley</p> <p>5. Drive belt auto-tensioner</p> <p>6. Engine hanger <R.H.></p> <p>● Alternator (Refer to Group16.)</p> | <p>◀B▶</p> <p>▶D▶</p> | <p>7. Power steering oil pump assembly</p> <p>8. A/C compressor assembly</p> <p>9. Compressor bracket</p> <p>10. Cooling fan bracket</p> <p>11. Accessory mount assembly</p> <p>12. Power steering oil pump bracket</p> |
|---------------------------|--|-----------------------|---|

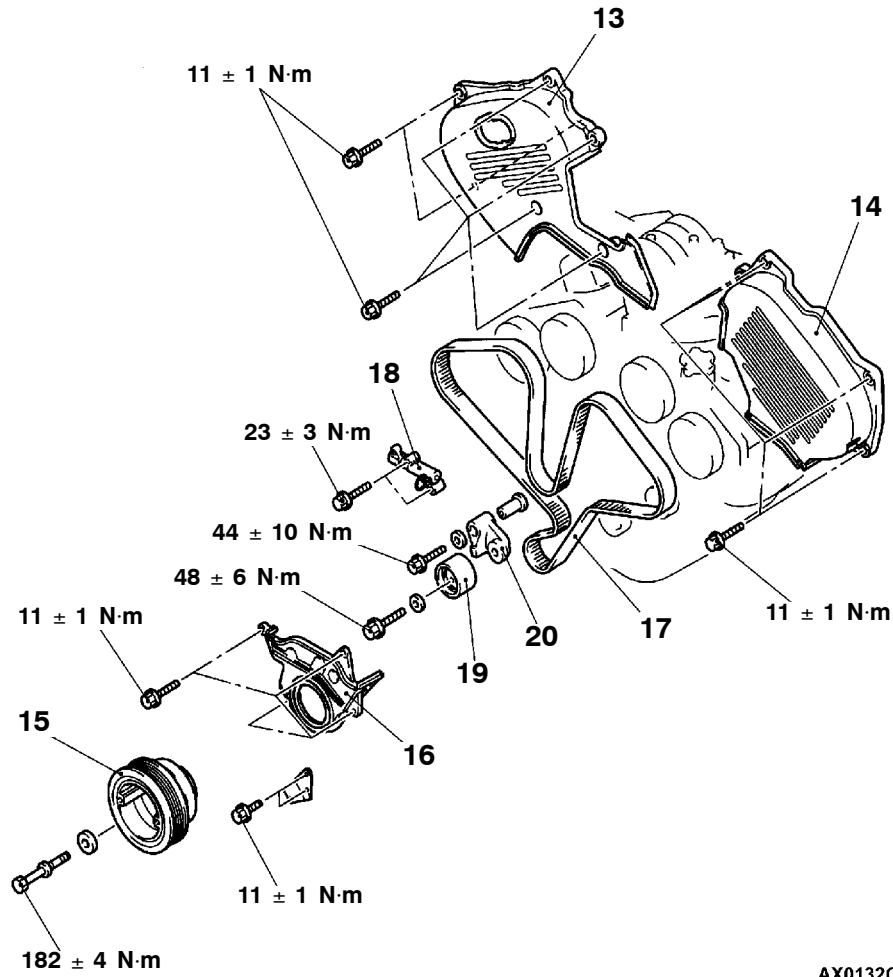

AX0132CA

Removal steps

- 13. Timing belt upper cover assembly <R.H.>
- 14. Timing belt upper cover assembly <L.H.>
- 15. Crankshaft pulley



- 16. Timing belt lower cover assembly
- 17. Timing belt
- 18. Auto-tensioner
- 19. Tension pulley
- 20. Tensioner arm assembly

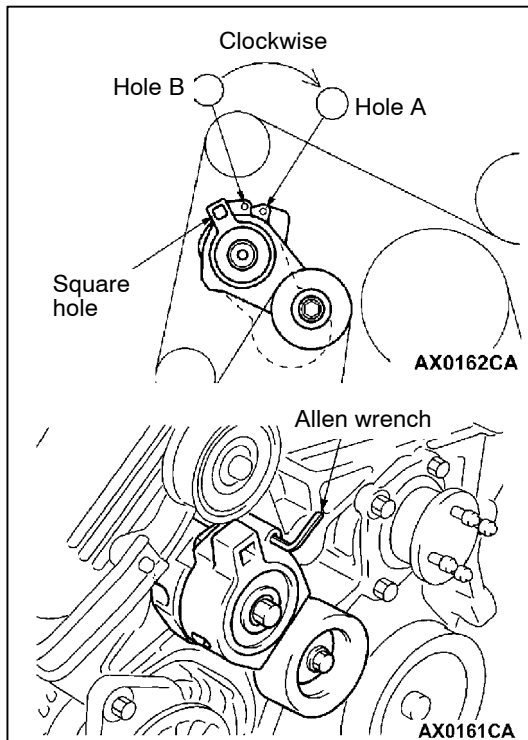

REMOVAL SERVICE POINTS

◀A▶ DRIVE BELT AUTO-TENSIONER REMOVAL

The following operations will be needed due to the introduction of the serpentine drive system with the drive belt auto tensioner.

1. Insert a 12.7 mm spinner handle into the square hole on the drive belt auto tensioner, and rotate it clockwise until the tensioner touches the stopper.
2. Align hole B with hole A, and insert a 5.0 mm Allen wrench to hold the tensioner. Then loosen the drive belt, and then remove the drive belt auto tensioner.

◀B▶ POWER STEERING OIL PUMP ASSEMBLY/A/C COMPRESSOR ASSEMBLY REMOVAL

1. Do not disconnect the hoses to remove the pump and compressor.
2. Support the removed pump and compressor with a wire, etc. so that they will not get in the way while working.

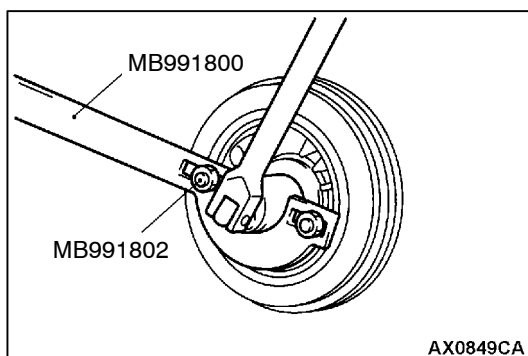

◀C▶ CRANKSHAFT PULLEY REMOVAL

Use special tools to remove the crankshaft pulley from the crankshaft.

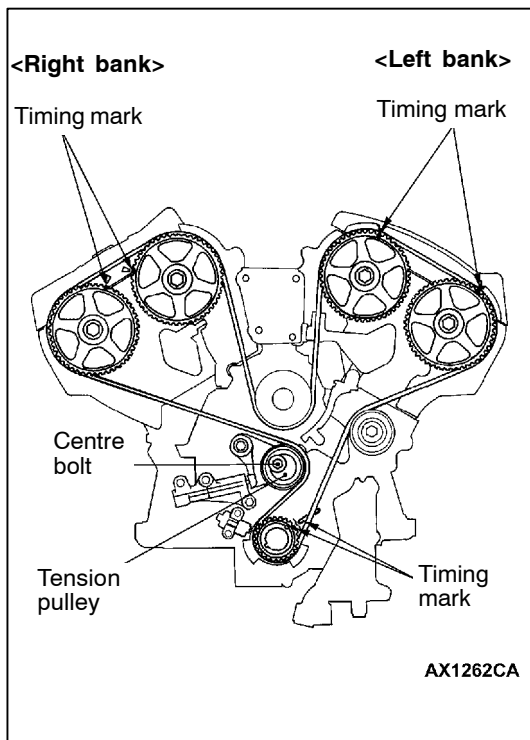

◀D▶ TIMING BELT REMOVAL

1. Turn the crankshaft clockwise to align each timing mark and to set the No. 1 cylinder to compression top dead centre.

Caution

- (1) **The camshaft sprocket (right side) can turn easily due to the valve spring force applied, so be careful not to get your fingers caught.**
 - (2) **Never turn the crankshaft anticlockwise.**
2. If the timing belt is to be reused, chalk mark the flat side of the belt with an arrow indicating the clockwise direction.
 3. Loosen the centre bolt of the tension pulley, and then remove the timing belt.

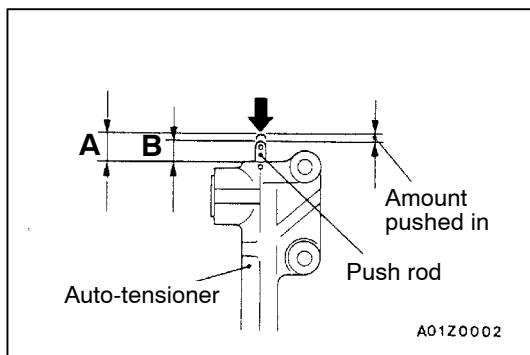

INSTALLATION SERVICE POINTS

▶A◀ AUTO-TENSIONER INSTALLATION

1. While holding the auto-tensioner by hand, press the end of the push rod against a metal surface (such as the cylinder block) with a force of 98 - 196 Nm and measure how far the push rod is pushed in.

Standard value: Within 1 mm

A: Length when no force is applied

B: Length when force is applied

A - B: Amount pushed in

2. If it is not within the standard value, replace the auto-tensioner.

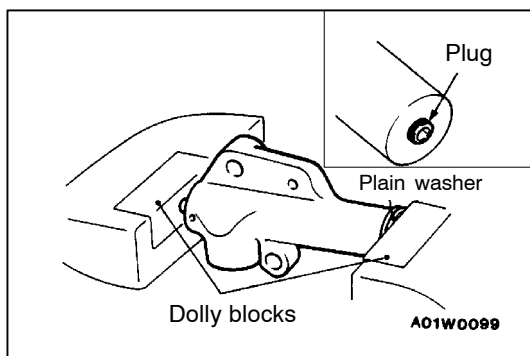

3. Place two dolly blocks in a vice as shown in the illustration, and then place the auto-tensioner in the vice.

Caution

- (1) **Place the auto-tensioner perpendicular to the jaws of the vice.**
- (2) **If there is a plug at the base of the auto-tensioner, insert a plain washer onto the end of the auto-tensioner to protect the plug.**

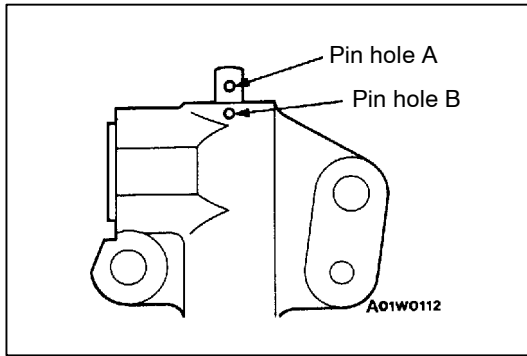

- Slowly compress the push rod of the auto-tensioner until pin hole A in the push rod is aligned with pin hole B in the cylinder.

Caution

Never compress the push rod too fast, or the push rod may be damaged.

- Insert the setting pin into the pin holes once they are aligned.

NOTE

If replacing the auto-tensioner, the pin will already be inserted into the pin holes of the new part.

- Install the auto-tensioner to the engine.

Caution

Do not remove the setting pin from the auto-tensioner.

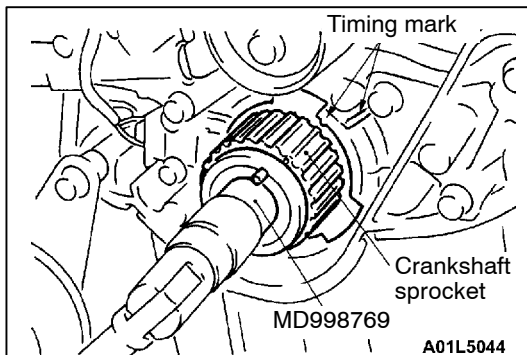
**▶B◀ TIMING BELT INSTALLATION**

- Use special tool to align the timing marks on the crankshaft sprocket.

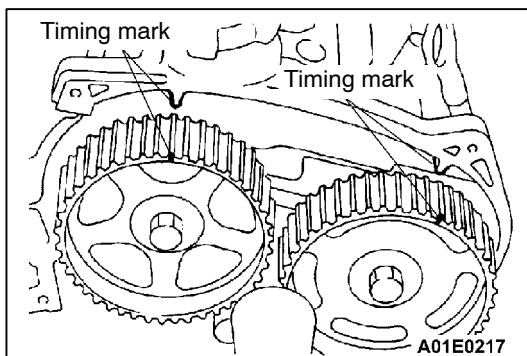

- Align the timing marks on the right bank side crankshaft sprocket.

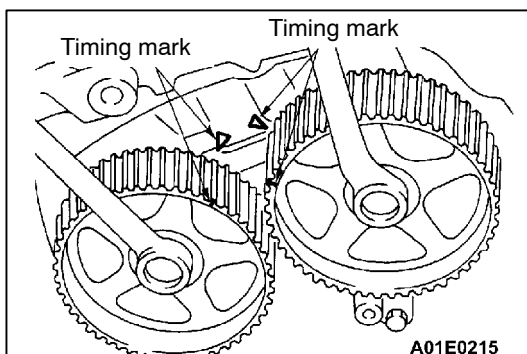

- Align the timing marks on the left bank side crankshaft sprocket, and then hold the sprocket with a wrench as shown.

Caution

(1) The left bank side camshaft sprockets will turn readily because of the spring force being applied, so be careful not to get your fingers caught.

- (2) If the sprocket on one side of the left bank is turned one full revolution while the sprocket timing marks on the opposite side of the left bank are aligned, the intake and exhaust valves will interfere.

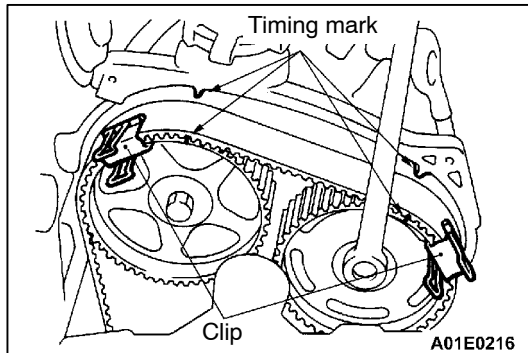

4. Set the timing belt onto the crankshaft sprocket.
5. Set the timing belt onto the idler pulley.
6. Check that the timing marks of the left bank side exhaust camshaft sprocket is aligned, and clamp the timing belt with a clip.
7. Set the timing belt onto the water pump pulley.

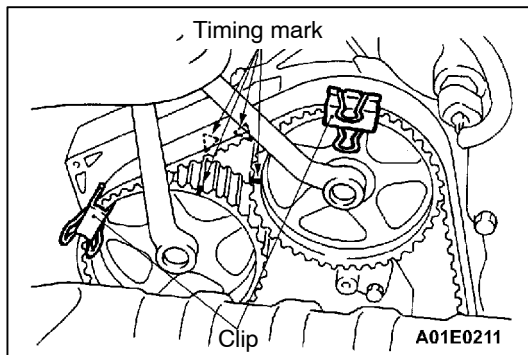

8. Check that the timing marks of the right bank side exhaust camshaft sprocket is aligned, and clamp the timing belt with a clip.
9. Set the timing belt onto the tension pulley.

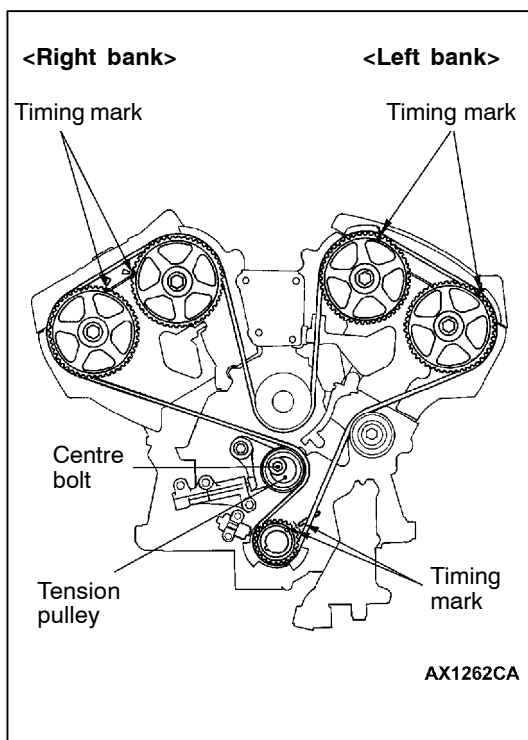

10. Turn the right bank side camshaft sprocket (exhaust side) anticlockwise until the tension side of the timing belt is firmly stretched. Check all timing marks again.

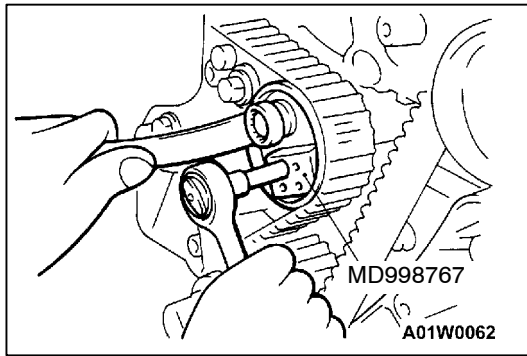

11. Use special tool to push the tensioner pulley into the timing belt, and then temporarily tighten the centre bolt.
12. Loosen all the clips.

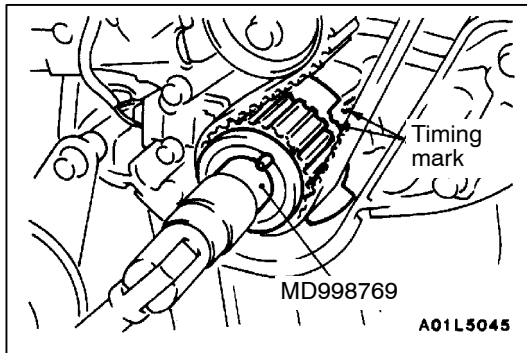

13. Use special tool to turn the crankshaft 1/4 turn anticlockwise and then turn it again clockwise until the timing marks are aligned.

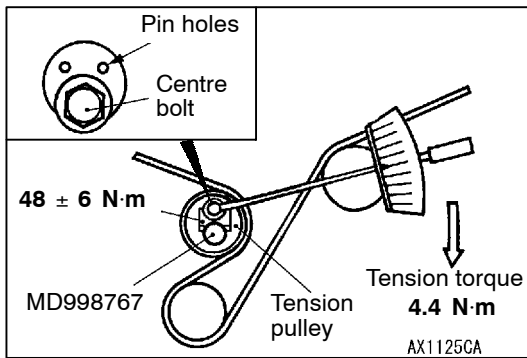

14. Loosen the centre bolt of the tensioner pulley. Use special tool and a torque wrench to apply the standard torque to the timing belt as shown in the illustration. Then tighten the centre bolt to the specified torque.

Standard value: 4.4 N·m
<Timing belt tension torque>

Caution

When tightening the centre bolt, be careful that the tensioner pulley does not turn with the bolt.

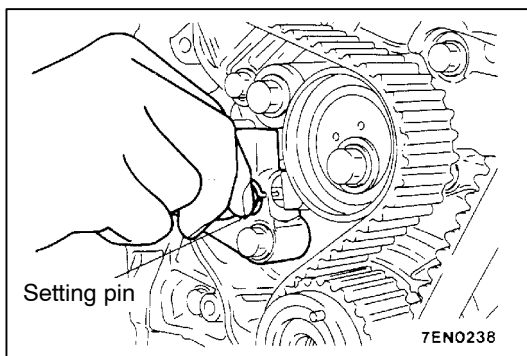

15. Remove the setting pin that has been inserted into the auto-tensioner.
16. Turn the crankshaft two turns clockwise to align the timing marks.

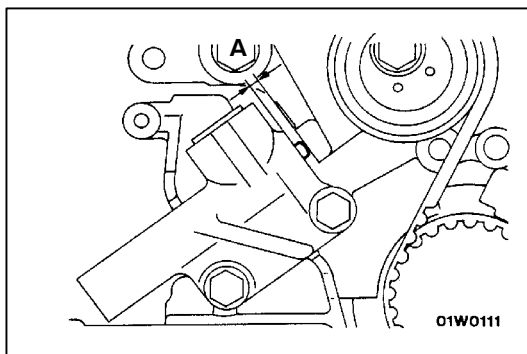

17. Wait for at least five minutes, and then check that the auto-tensioner pushrod extends within the standard value.
Standard value (A): 3.8 - 5.0 mm
18. If no, repeat the operation in steps (13) to (17) above.
19. Check again that the timing marks of each sprocket are aligned.

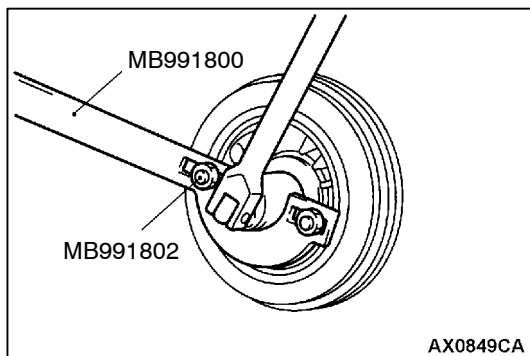

►C◄ CRANKSHAFT PULLEY INSTALLATION

Use special tools MD991800 and MB991802 to install the crankshaft pulley.

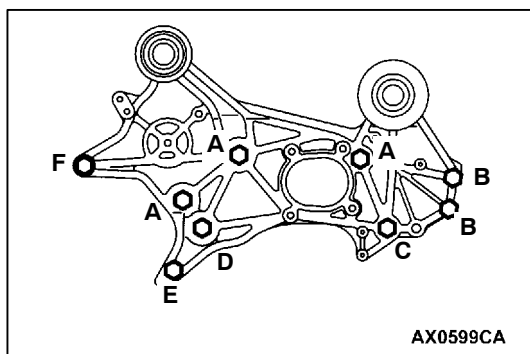

►D◄ ACCESSORY MOUNT ASSEMBLY INSTALLATION

Install the bolts to the shown positions, and tighten them to the specified torque.

Bolt (symbol)	Diameter × length mm	Tightening torque(N·m)
A	10×100	41 ± 8
B	10×30	41 ± 8
C	10×100	44 ± 10
D	12×100	74 ± 9
E	8×30	22 ± 4
F	10×106	44 ± 10

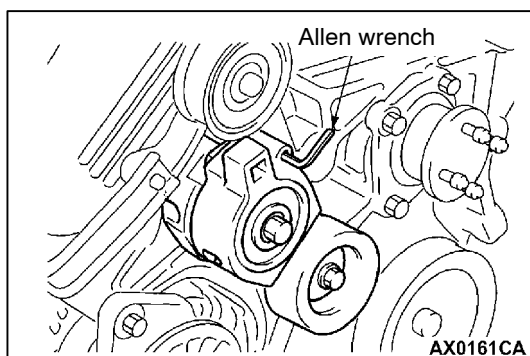

►E◄ DRIVE BELT AUTO TENSIONER INSTALLATION

1. Install the drive belt auto tensioner with the Allen wrench inserted.
2. After the drive belt has been installed, remove the Allen wrench while holding the drive belt auto tensioner with a socket wrench drive. Then release the drive belt auto tensioner slowly.

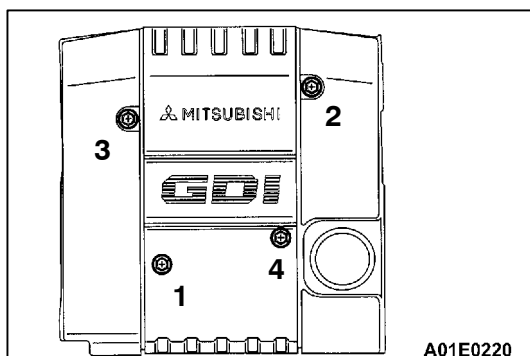

►F◄ ENGINE COVER INSTALLATION

Install the engine cover bolts finger-tight, and tighten them to the specified torque in the order shown.

Tightening torque: 3.0 ± 0.4 N·m

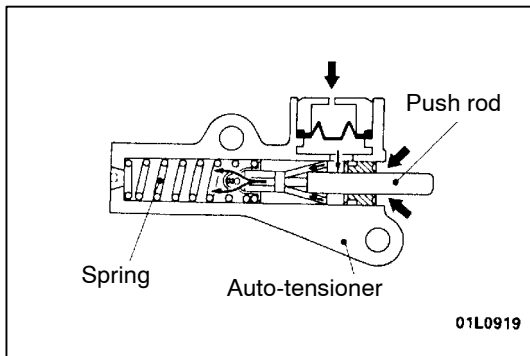

INSPECTION

AUTO-TENSIONER

- Check the auto-tensioner for possible leaks.
- Check the push rod for cracks.

CRANKSHAFT OIL SEAL

REMOVAL AND INSTALLATION

Pre-removal and Post-installation Operation

- Timing Belt Removal and Installation (Refer to P.11A-15.)

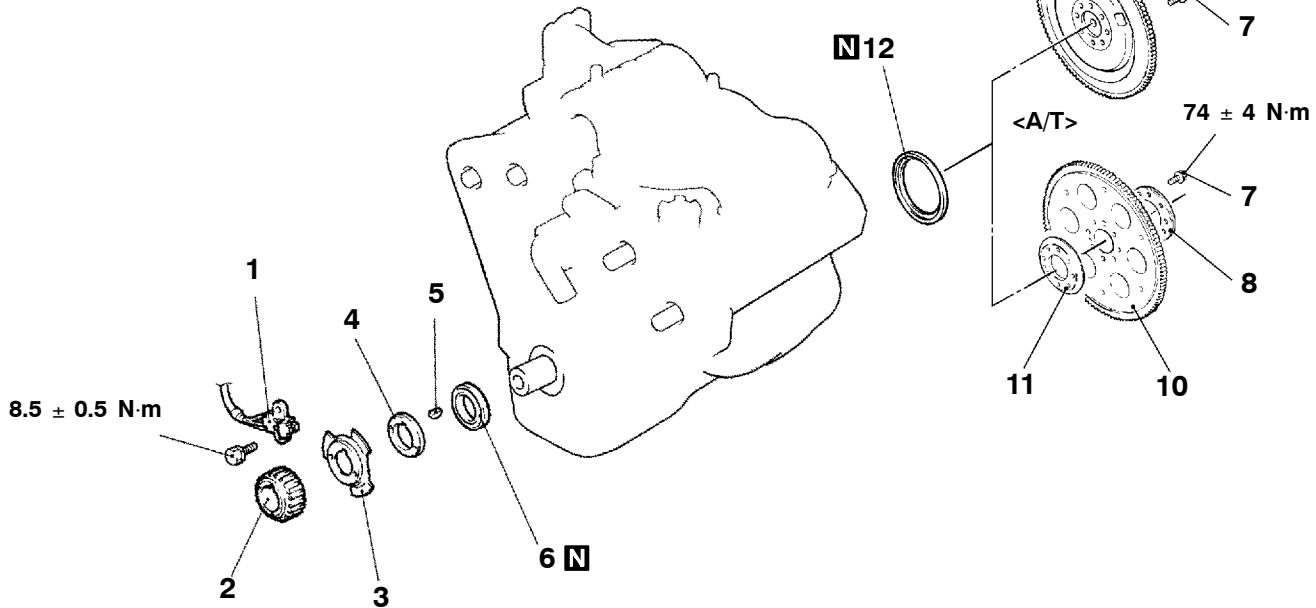
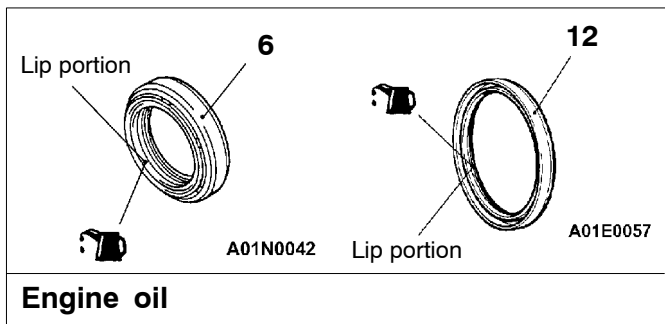

AY0268CA

Removal steps

- ◀D▶ 1. Crank angle sensor
- ◀D▶ 2. Crankshaft sprocket
- ◀D▶ 3. Crankshaft sensing blade
- ▶C▶ 4. Crankshaft spacer
- ▶C▶ 5. Key
- ▶C▶ 6. Crankshaft front oil seal

- ◀A▶ ▶B▶ 7. Bolt
- ▶A▶ 8. Adaptor plate
- ▶A▶ 9. Flywheel
- ▶A▶ 10. Drive plate
- ▶A▶ 11. Crankshaft adaptor
- ▶A▶ 12. Crankshaft rear oil seal

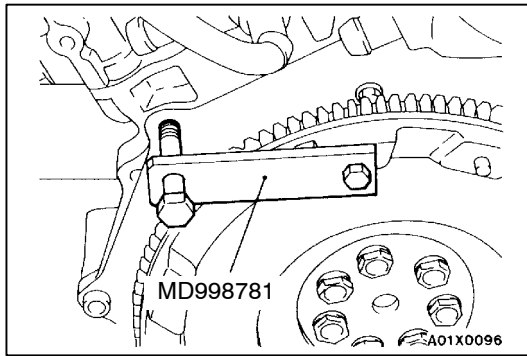
**REMOVAL SERVICE POINT****◀A▶ BOLT REMOVAL**

Use special tool to secure the flywheel or drive plate and remove the bolt.

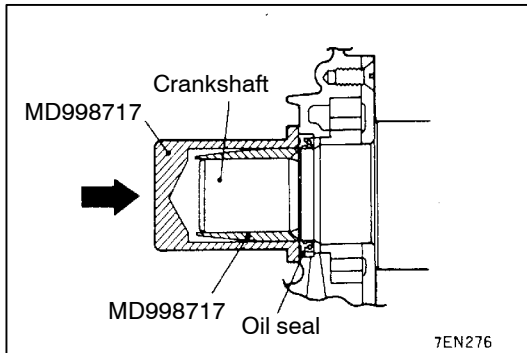
**INSTALLATION SERVICE POINTS****▶A◀ CRANKSHAFT REAR OIL SEAL INSTALLATION**

1. Apply a small amount of engine oil to the entire circumference of the oil seal lip.
2. Use special tool to tap in the oil seal as shown in the illustration.

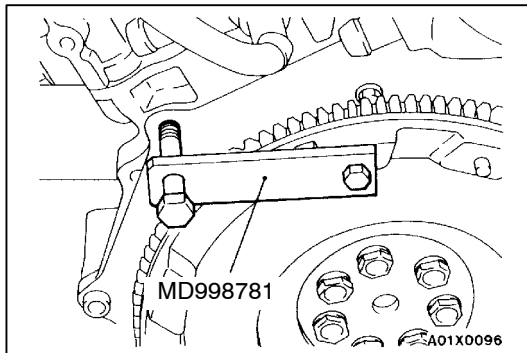
**▶B◀ BOLT INSTALLATION**

Use special tool in the same way as during removal to install the bolt.

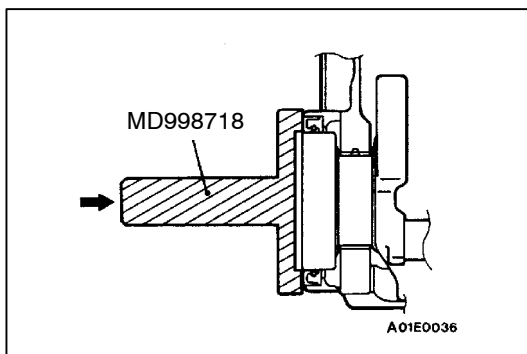
**▶C◀ CRANKSHAFT FRONT OIL SEAL INSTALLATION**

1. Apply a small amount of engine oil to the oil seal lip and then insert.
2. Using special tool, tap the oil seal into the front case.

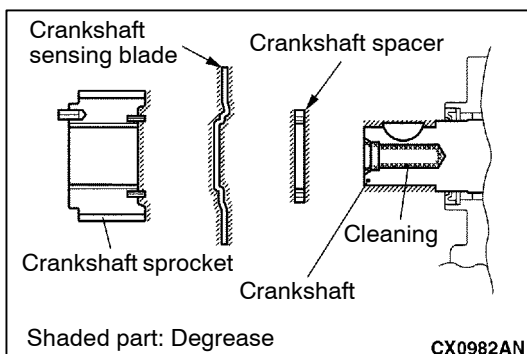
**▶D◀ CRANKSHAFT SPACER/CRANKSHAFT SENSING BLADE/CRANKSHAFT SPROCKET**

To prevent the crankshaft pulley mounting bolt from loosening, degrease or clean the crankshaft, the crankshaft spacer, the crankshaft sensing blade and the crankshaft at the shown positions.

CAMSHAFT OIL SEAL

REMOVAL AND INSTALLATION

Pre-removal and Post-installation Operation

- Timing Belt Removal and Installation (Refer to P.11A-15.)

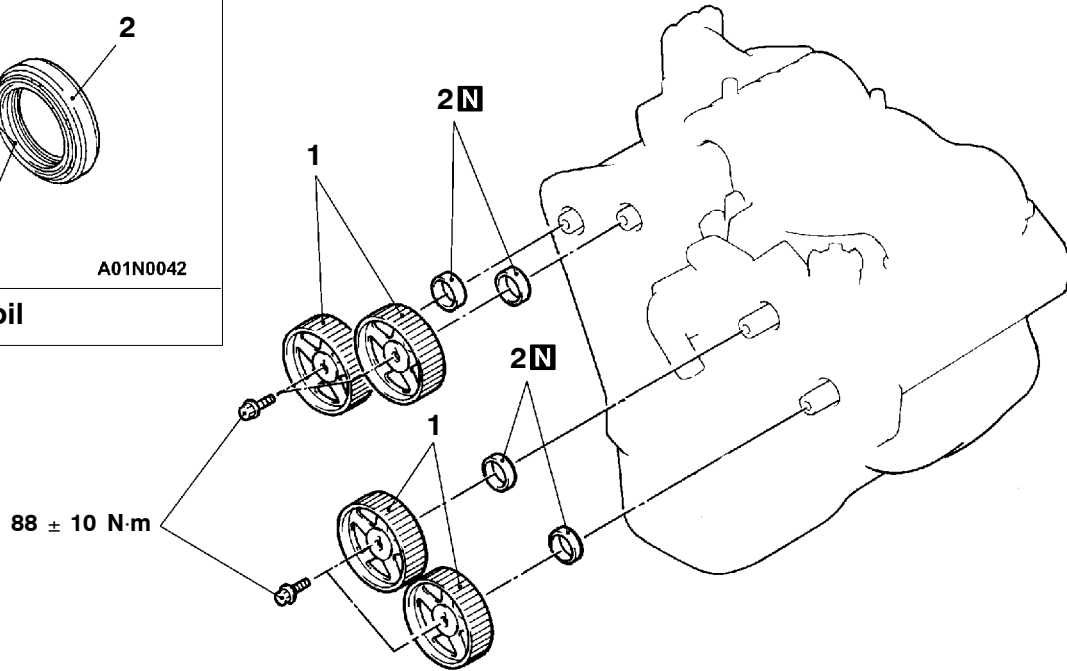
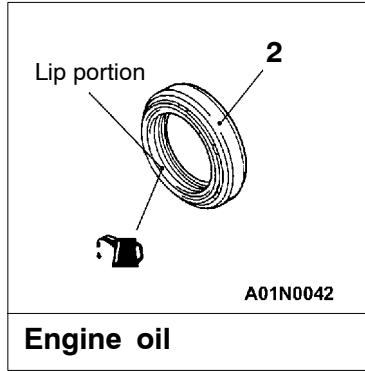

A01E0195

Removal steps



1. Camshaft sprocket
2. Camshaft oil seal

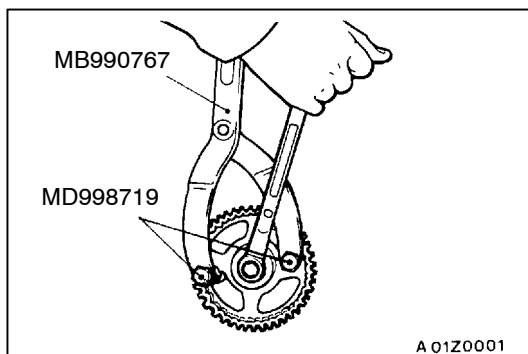

REMOVAL SERVICE POINTS

◀A▶ CAMSHAFT SPROCKET REMOVAL

Use special tools to remove the camshaft sprocket.

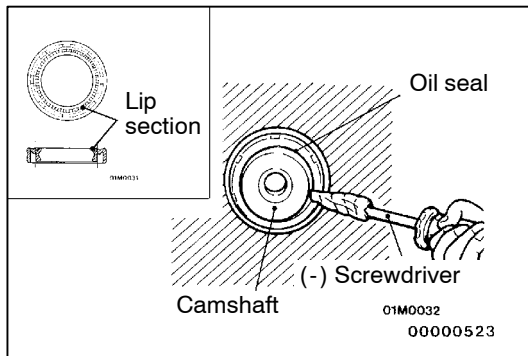

◀B▶ CAMSHAFT OIL SEAL REMOVAL

1. Make a notch in the oil seal lip section with a knife, etc.
2. Cover the end of a flat-tipped screwdriver with a shop towel and insert into the notched section of the oil seal, and pry out the oil seal to remove it.

Caution

Be careful not to damage the camshaft and the cylinder head.

INSTALLATION SERVICE POINTS

▶A▶ CAMSHAFT OIL SEAL INSTALLATION

1. Apply engine oil to the camshaft oil seal lip.
2. Use special tools to press-fit the camshaft oil seal.

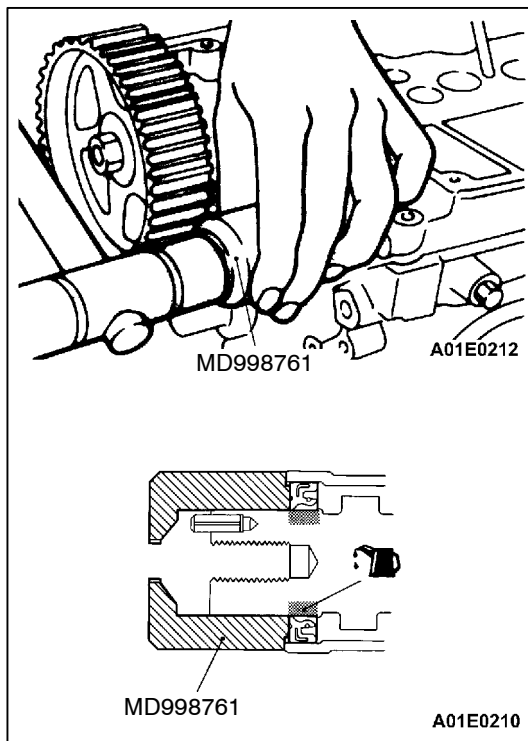

▶B▶ CAMSHAFT SPROCKET INSTALLATION

Use special tools in the same way as during removal to install the camshaft sprocket.

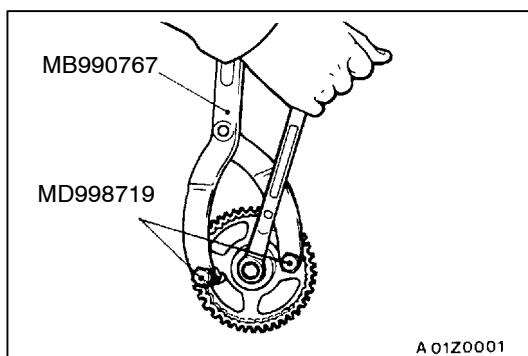

CYLINDER HEAD GASKET

REMOVAL AND INSTALLATION

Pre-removal and Post-installation Operation

- Fuel Discharge Prevention (Pre-removal operation)
- Engine Coolant Draining and Refilling (Refer to GROUP 14 - On-vehicle Service.)
- Engine Oil Draining and Refilling (Refer to GROUP 12 - On-vehicle Service.)
- Front Exhaust Pipe Removal and Installation (Refer to GROUP 15 - Exhaust Pipe and Main Muffler.)
- Timing Belt Removal and installation (Refer to P.11A-15.)
- Thermostat Case and Water Inlet Fitting Removal and Installation (Refer to GROUP 14 - Water Pump.)
- Intake Manifold Removal and Installation (Refer to GROUP 15 - Intake Manifold.)
- Fuel Pump (High Pressure) Removal and Installation (Refer to GROUP 13.)

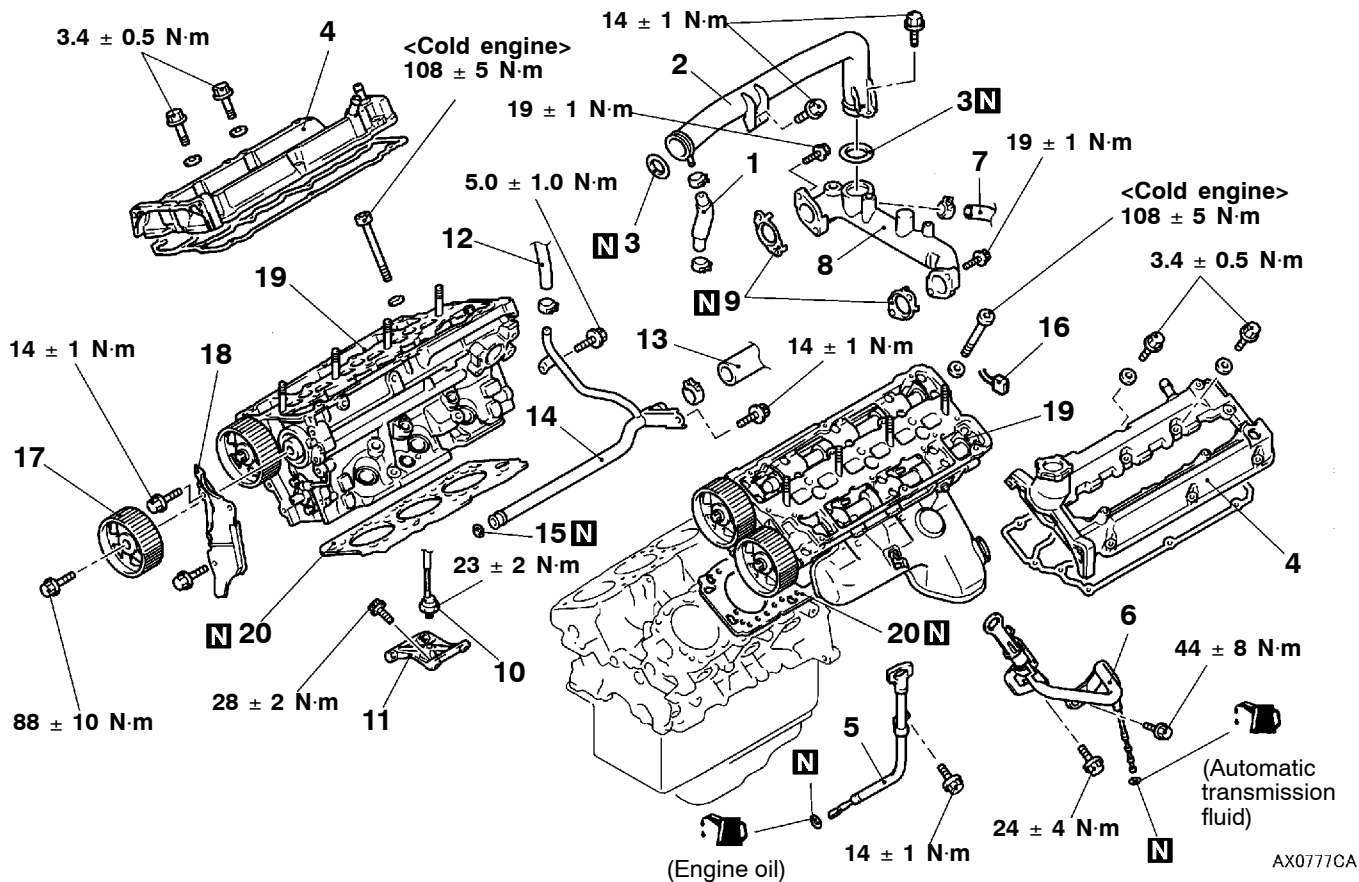

Removal steps

- | | |
|--|---|
| <p>1. Water hose</p> <p>2. Water outlet pipe assembly</p> <p>3. O-ring</p> <p>4. Rocker cover</p> <p>5. Oil dipstick assembly <when removing left bank only></p> <p>6. A/T Fluid dipstick assembly <when removing left bank only></p> <p>7. Heater hose connection</p> <p>8. Water passage assembly</p> <p>9. Gasket</p> <p>10. Detonation sensor</p> <p>11. Detonation sensor bracket</p> | <p>12. Water hose connection</p> <p>13. Heater hose connection</p> <p>14. Water pipe assembly</p> <p>15. O-ring</p> <p>16. Camshaft position sensor connector <when removing left bank only></p> <p>17. Camshaft sprocket (Intake side) <when removing right bank only></p> <p>18. Timing belt rear cover <when removing right bank only></p> <p>19. Cylinder head assembly</p> <p>20. Cylinder head gasket</p> |
|--|---|

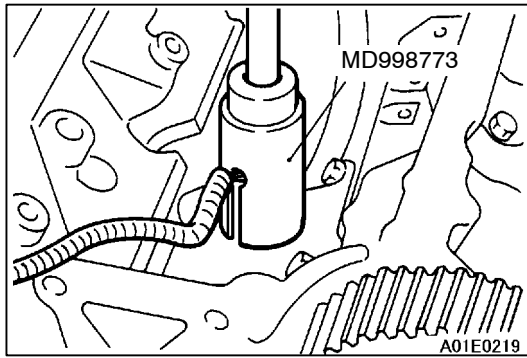
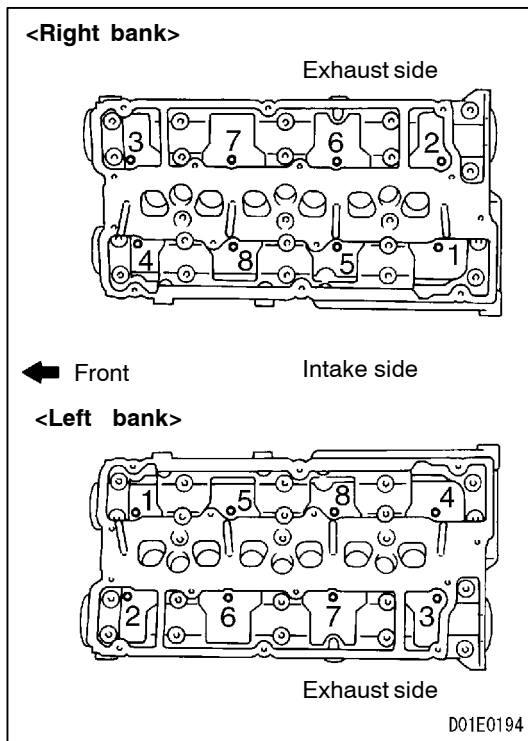
**REMOVAL SERVICE POINTS****◀A▶ DETONATION SENSOR REMOVAL****◀B▶ CYLINDER HEAD ASSEMBLY REMOVAL**

Loosen the bolts in 2 or 3 steps in order of the numbers shown in the illustration, and remove the cylinder head bolt.

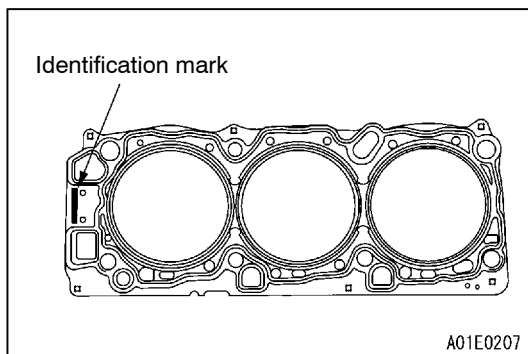
**IINSTALLATION SERVICE POINTS****▶A◀ CYLINDER HEAD GASKET INSTALLATION**

1. Degrease the cylinder head and cylinder block gasket mounting surfaces.
2. Make sure that the gasket has the proper identification mark for the engine.
3. Lay the cylinder head gasket on the cylinder block with the identification mark at the front top.

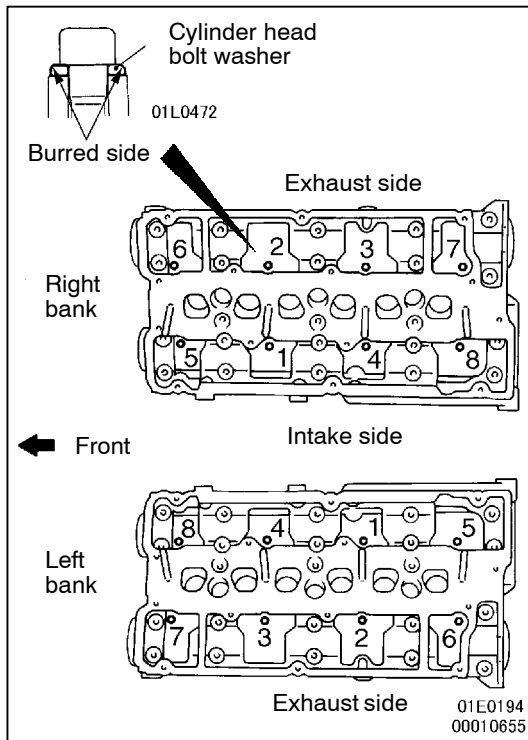

►B◄ CYLINDER HEAD ASSEMBLY INSTALLATION

Tighten the bolts in 2 or 3 steps in order of the numbers shown in the illustration, and install the cylinder head bolt.

Caution

Install the head bolt washers with the beveled side facing upwards as shown in the illustration.

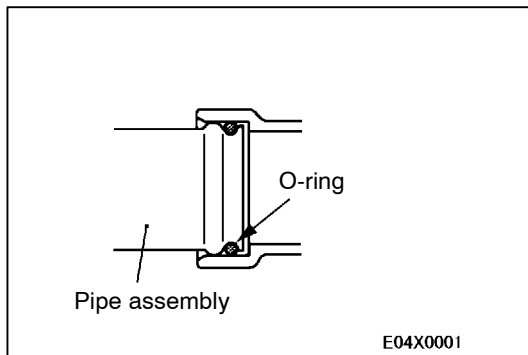

►C◄ O-RING INSTALLATION

Insert the O-ring to the water inlet pipe assembly and coat the outer circumference of the O-ring with water.

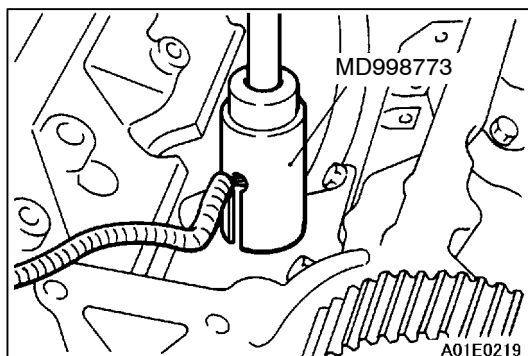

►D◄ DETONATION SENSOR INSTALLATION

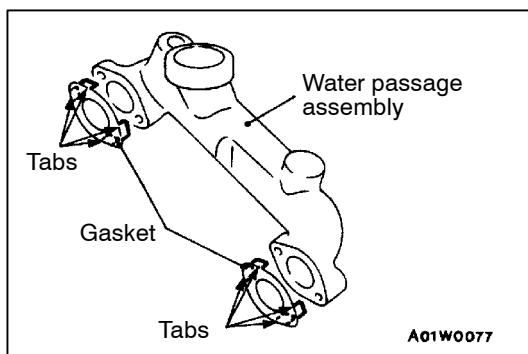

►E◄ GASKET/WATER PASSAGE ASSEMBLY INSTALLATION

Bend the tabs onto the water passage assembly. Then install the water passage assembly to the cylinder head so that the gasket doesn't slip.

ENGINE ASSEMBLY

REMOVAL AND INSTALLATION

Caution

*: Indicates parts which should be initially tightened, and then fully tightened after placing the vehicle horizontally and loading the full weight of the engine on the vehicle body.

Pre-removal and Post-installation Operation

- Hood Removal and Installation (Refer to GROUP 42 - Hood.)
- Skid Plate and Under Cover Removal and Installation
- Fuel Discharge Prevention (Pre-removal operation)
- Engine Coolant Draining and Refilling (Refer to GROUP 14 - On-vehicle Service.)
- Air Cleaner and Air Intake Hose Removal and Installation (Refer to GROUP 15 - Air Cleaner.)
- Battery, Battery Tray and Bracket Removal and Installation
- Radiator Removal and Installation (Refer to GROUP 14 - Radiator.)
- Engine Oil Draining and Refilling (Refer to GROUP 12 - On-vehicle Service.)
- Front Exhaust Pipe Removal (Refer to GROUP 15 - Exhaust Pipe and Main Muffler.)
- Transmission Assembly Removal and Installation (Refer to GROUP 22,23 - Transmission Assembly.)

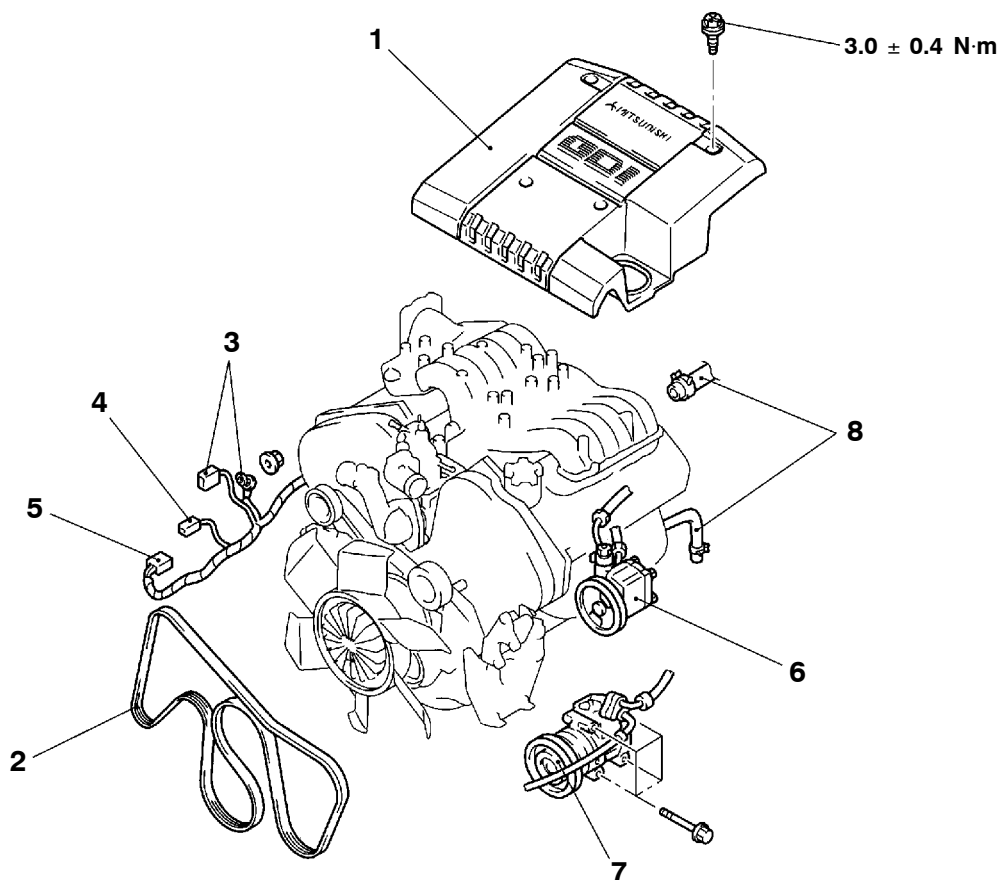

AX0164CA

Removal steps



1. Engine cover
2. Drive belt
3. Alternator connector
4. Starter motor connector



5. Freewheel engage switch connector
6. Power steering oil pump assembly
7. A/C compressor assembly
8. Heater hose connection

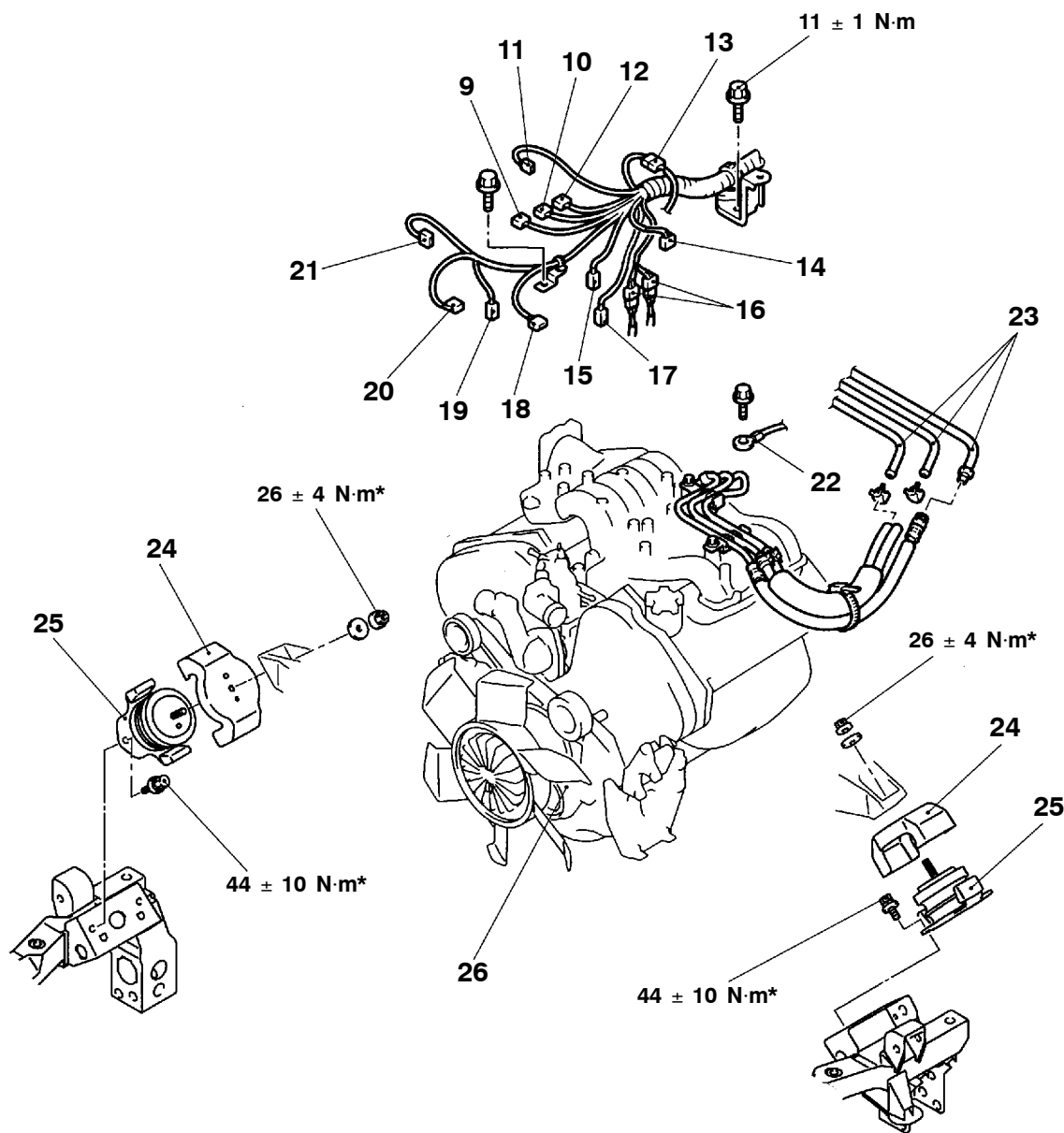

X0166CA
X0393CA
00010658

- | | |
|--|---|
| <ul style="list-style-type: none"> 9. Ignition failure sensor connector 10. Detonation sensor connector 11. Throttle position sensor connector 12. Control wiring harness and injector wiring harness connection 13. Control wiring harness and ignition wiring harness connection 14. Fuel pressure sensor harness, camshaft position sensor harness and control wiring harness injector wiring harness connection 15. Purge control solenoid valve connector 16. Control wiring harness and battery cable connection | <ul style="list-style-type: none"> 17. Oxygen sensor connector 18. Crank angle sensor connector 19. Engine coolant temperature gauge unit connector 20. Engine coolant temperature sensor connector 21. Throttle valve control servo connector 22. Battery cable connection 23. Fuel pipe and hose connection 24. Heat protector 25. Engine front mount insulator 26. Engine assembly |
|--|---|



REMOVAL SERVICE POINTS**◀A▶ POWER STEERING OIL PUMP ASSEMBLY AND A/C COMPRESSOR ASSEMBLY REMOVAL**

1. Remove the oil pump and A/C compressor (with the hose attached).
2. Suspend the removed oil pump (by using wire or similar material) at a place where no damage will be caused during removal/installation of the engine assembly.

◀B▶ ENGINE ASSEMBLY REMOVAL

1. Check that all cables, hoses, harness connectors, etc. are disconnected from the engine.
2. Lift the special tool (MB991683) and chain block slowly to remove the engine assembly upward from the engine compartment.

INSTALLATION SERVICE POINT**▶A◀ ENGINE ASSEMBLY INSTALLATION**

Install the engine assembly. When doing so, check carefully that all pipes and hoses are connected, and that none are twisted, damaged, etc.

▶B◀ ENGINE COVER INSTALLATION

Install the engine cover bolts finger-tight, and tighten them to the specified torque in the order shown.

Tightening torque: 3.0 ± 0.4 N·m

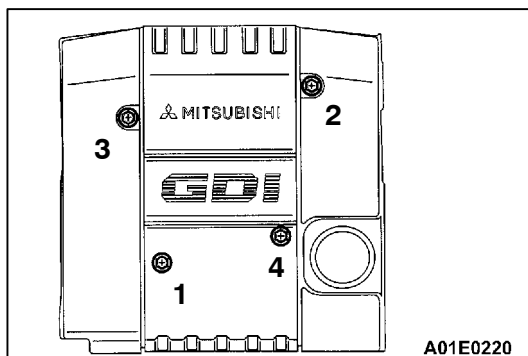

ENGINE <4D5>

Click on the applicable bookmark to selected the required model year.

ENGINE <4D5>

CONTENTS

GENERAL INFORMATION	2	Compression Pressure Check	13
SERVICE SPECIFICATIONS	3	Timing Belt Tension Adjustment	14
SEALANTS	3	Timing Belt B Tension Adjustment	15
SPECIAL TOOLS	4	OIL PAN AND OIL SCREEN	17
ON-VEHICLE SERVICE	5	TIMING BELT AND TIMING BELT B	19
Drive Belt Tension Check and Adjustment	5	CRANKSHAFT OIL SEAL	25
Auto-tensioner check	7	CAMSHAFT AND CAMSHAFT OIL SEAL ..	27
Valve Clearance Check and Adjustment	8	CYLINDER HEAD GASKET	30
Injection Timing Check and Adjustment	9	ENGINE ASSEMBLY	34
Idle Speed Check and Adjustment	12		
Idle-up Mechanism Check and Adjustment-For A/C	12		

GENERAL INFORMATION

Items		4D56	
Total displacement mL		2,477	
Bore x Stroke mm		91.1 x 95.0	
Compression ratio		21	
Combustion chamber		Vortex chamber type	
Camshaft arrangement		SOHC	
Number of valve	Intake	4	
	Exhaust	4	
Valve timing	Intake	Opening	BTDC 20°
	Exhaust	Closing	ABDC 49°
	Intake	Opening	BBDC 55°
	Exhaust	Closing	ATDC 22°
Fuel system		Distribution type injection pump	
Rocker arm		Roller type	
Adjusting screw		Elephant foot type	

SERVICE SPECIFICATIONS



Items		Standard value	Limit
A/C compressor drive belt (When inspection)	Vibration frequency Hz	157 - 176	—
	Tension N	260 - 325	—
	Deflection mm <Reference>	8.0 - 8.5	—
A/C compressor drive belt (When adjustment)	Vibration frequency Hz	157 - 176	—
	Tension N	260 - 325	—
	Deflection mm <Reference>	8.0 - 8.5	—
A/C compressor drive belt (When replacement)	Vibration frequency Hz	192 - 208	—
	Tension N	390 - 450	—
	Deflection mm <Reference>	6.5 - 7.0	—
Valve clearance (at hot) mm		0.25	-
Injection timing (Value indicated on dial gauge mm)		9° ATDC (1 ± 0.03)	-
Idle speed r/min		750 ± 100	-
Compression pressure kPa (at engine speed of 280 r/min)		3,040	Min. 2,256
Compression pressure difference of all cylinder (at engine speed of 280 r/min) kPa		-	Max. 294
Timing belt tension mm		4 - 5	
Timing belt B tension mm		4 - 5	

SEALANTS

Items	Specified sealant	Remarks
Oil pan	MITSUBISHI GENUINE PART MD970389 or equivalent	Semi-drying sealant
Semi-circular packing and rocker cover gasket seal, and cylinder head seal	3M ATD Part No. 8660 or equivalent	

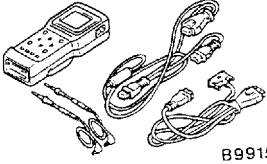
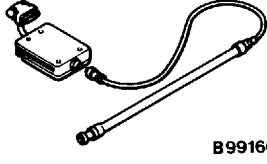
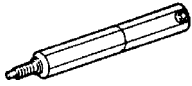
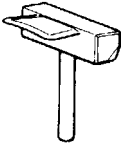
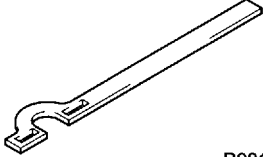
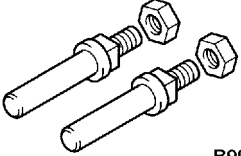
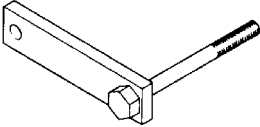
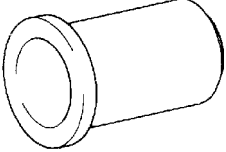
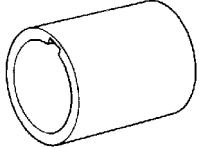
SPECIAL TOOLS

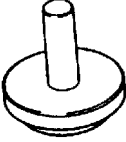
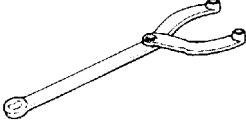
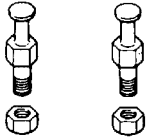
Tools	Number	Name	Use
 B991502	MB991502	MUT-II sub-assembly	Drive belt tension measurements
 B991668	MB991668	Belt tension meter set	
	MD998384	Prestroke measuring adapter	Adjustment of the injection timing
	MD998727	Oil pan remover	Removal of oil pan
 B991800	MB991800	Crankshaft pulley holder	Holding the crankshaft pulley
 B991802	MB991802	Pin B	
	MD998781	Flywheel stopper	Securing the flywheel
	MD998382	Crankshaft front oil seal installer	Installing the crankshaft front oil seal
	MD998383	Crankshaft front oil seal guide	

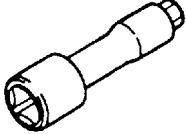
Tools	Number	Name	Use
	MD998376	Crankshaft rear oil seal installer	Press-fitting the crankshaft rear oil seal
	MB990767	End yoke holder	Holding the camshaft sprocket
	MD998719	Crankshaft pulley holder pin	
	MD998381	Camshaft oil seal installer	Installing the camshaft oil seal
	MD998051	Cylinder head bolt wrench	Removal and installation of the cylinder head bolt

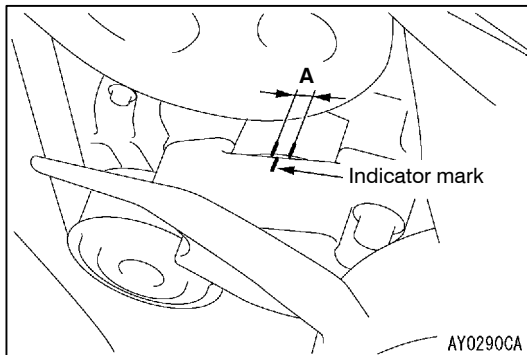

ON-VEHICLE SERVICE

DRIVE BELT TENSION CHECK AND ADJUSTMENT

ALTERNATOR AND POWER STEERING OIL PUMP DRIVE BELT TENSION CHECK

Caution

Perform the check after rotating the engine to the normal direction (one revolution and over).

1. Check that the indicator mark of the auto-tensioner is located within the scope shown as "A" on the tensioner bracket.
2. If the mark is located out of the scope "A," replace the drive belt.

NOTE

Since the auto-tensioner is used, it is not necessary to adjust the tension of the belt.

A/C COMPRESSOR DRIVE BELT TENSION CHECK AND ADJUSTMENT <VEHICLES WITH A/C>

1. Check the drive belt tension by the following procedures.

Standard value:

Item	During inspection	During adjustment	During replacement
Vibration frequency Hz	157 - 176	157 - 176	192 - 208
Tension N	260 - 325	260 - 325	390 - 450
Deflection mm <Reference>	8.0 - 8.5	8.0 - 8.5	6.5 - 7.0

<When using MUT-II>

- (1) Connect the MUT-II to the special tool (MB991668).
- (2) Connect the MUT-II to the diagnosis connector.

Caution

Always turn the ignition switch to LOCK (OFF) position before disconnecting or connecting the MUT-II.

- (3) Turn the ignition switch to ON, and select the "Belt tension measurement" on the menu screen.
- (4) Hold a microphone to the middle of the drive belt between the pulleys (at the place indicated by the arrow), approximately 10 - 20 mm away from the rear surface of the belt and so that it is perpendicular to the belt (within an angle of $\pm 15^\circ$).
- (5) Gently tap the middle of the belt between the pulleys (the place indicated by the arrow) with your finger as shown in the illustration, and check that the vibration frequency of the belt is within the standard value.

Caution

- 1) The temperature of the surface of the belt should be as close to normal temperature as possible.
- 2) Do not allow any contaminants such as water or oil to get onto the microphone.
- 3) If strong gusts of wind blow against the microphone or if there are any loud sources of noise nearby, the values measured by the microphone may not correspond to actual values.
- 4) If the microphone is touching the belt while the measurement is being made, the values measured by the microphone may not correspond to actual values.
- 5) Do not take the measurement while the vehicle's engine is running.

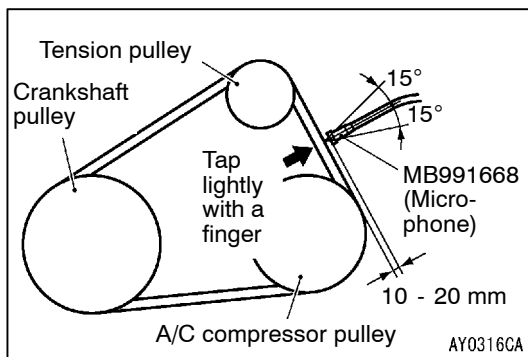

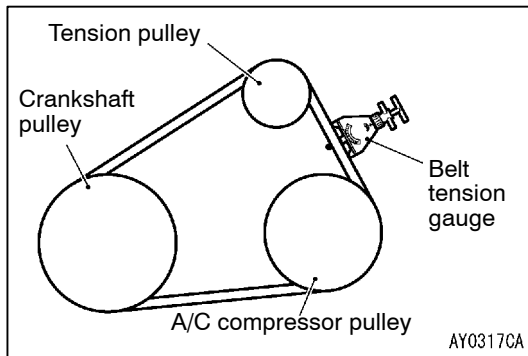
**<When using a tension gauge>**

Use a belt tension gauge to check that the belt tension is within the standard value.

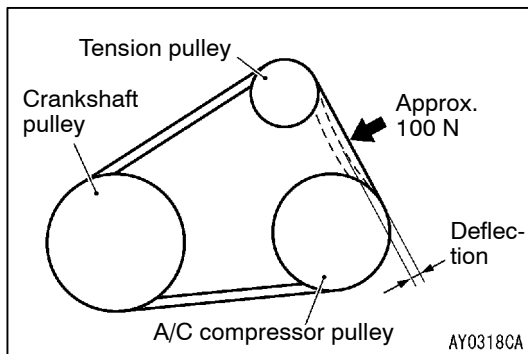
**<When checking the deflection>**

Apply approx. 100 N of force to the middle of the drive belt between the pulleys (at the place indicated by the arrow) and check that the amount of deflection is within the standard value.

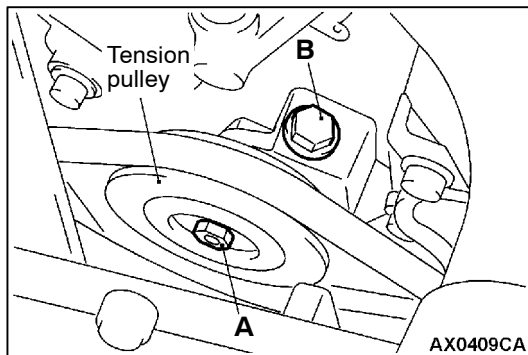

2. If not within the standard value, adjust the belt tension by the following procedure.

- (1) Loosen the tension pulley securing bolt A.
- (2) Use the adjusting bolt B to adjust the belt deflection.
- (3) Tighten the securing bolt A to the specified torque.

Tightening torque: 44 ± 10 N·m

- (4) Check the belt tension, and readjust if necessary.

Caution

When checking the belt tension, turn the crankshaft clockwise one turn or more.

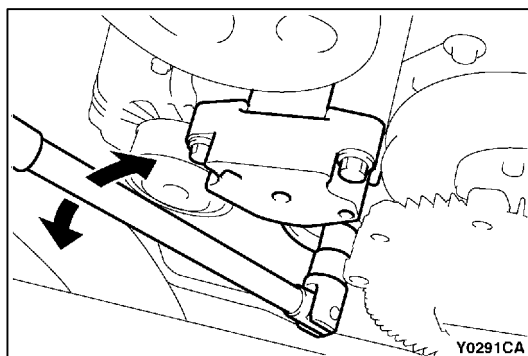
**AUTO-TENSIONER CHECK**

1. Run the engine at idling speed and then stop it to check whether the drive belt is forced out from the width of the auto-tensioner pulley.
2. Remove the alternator and power steering oil pump drive belt. (Refer P.11B-19.)
3. Locate a ring spanner onto the auto-tensioner pulley mounting bolt, and move the tensioner back and forth to confirm there is no stiffness.
4. If some abnormality is found during the above mentioned check (1) and (3), replace the auto-tensioner.
5. Install the alternator and power steering oil pump drive belt. (Refer P.11B-19.)

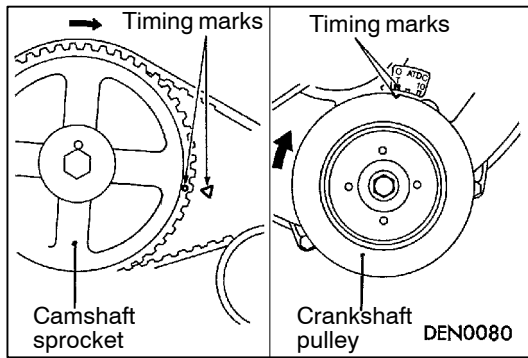

VALVE CLEARANCE CHECK AND ADJUSTMENT

1. Start the engine and allow it to warm up until the engine coolant temperature reaches 80 to 90 °C.
2. Remove the timing belt upper cover.
3. Remove the rocker cover.
4. Align the camshaft sprocket timing marks and set the No. 1 cylinder at top dead centre.

Caution

The crankshaft should always be turned in a clockwise direction.

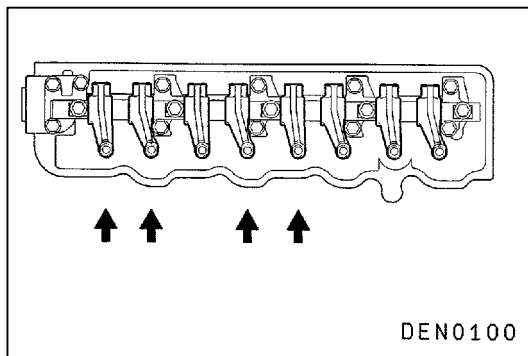

5. Measure the valve clearance at the places indicated by arrows in the illustration.

Standard value: 0.25 mm

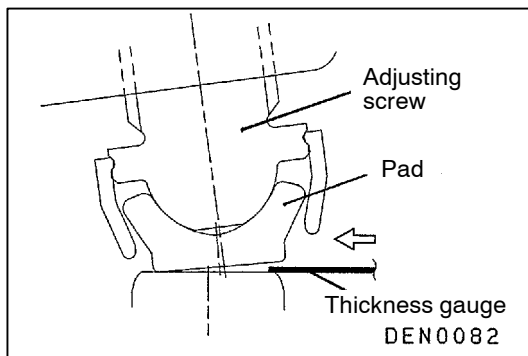

NOTE

Insert the thickness gauge from the centre of the cylinder head towards the outside so that it doesn't touch the pad.

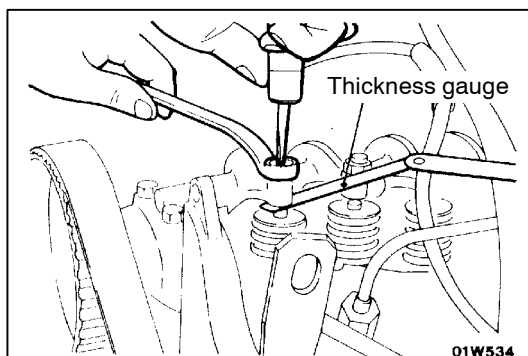

6. If the clearance is outside the standard value, loosen the lock nut of the rocker arm and adjust by turning the adjusting screw while using a thickness gauge to measure the clearance.
7. Tighten the lock nut while holding the adjusting screw with a screwdriver so that it doesn't turn.
8. Turn the crankshaft 360° clockwise to bring No. 4 cylinder to the top dead centre position.

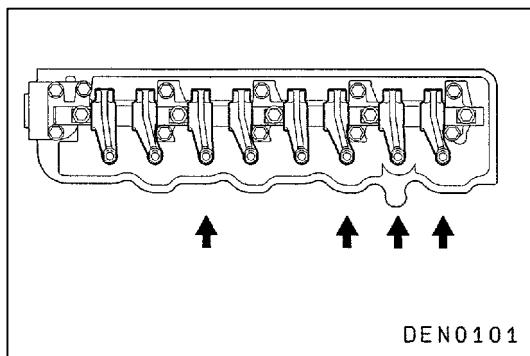

- Measure the valve clearances at the places indicated by arrows in the illustration. If the clearance is not within the standard value, repeat steps 7 and 8 above.

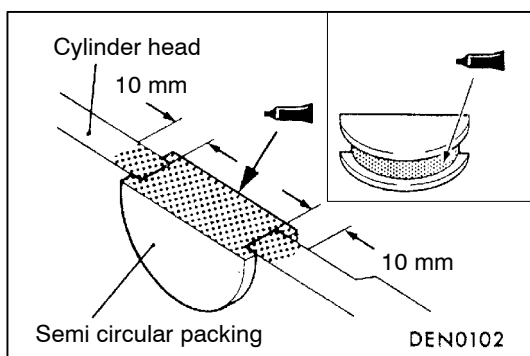

- Apply specified sealant to the section of the semi-circular packing shown in the illustration.

Specified sealant: 3M ATD Part No. 8660 or equivalent

- Install the rocker cover.
- Install the timing belt upper cover.

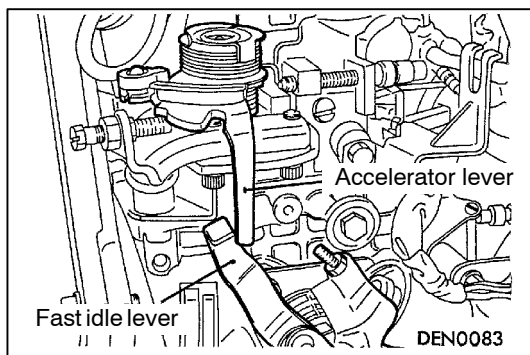

INJECTION TIMING CHECK AND ADJUSTMENT

- Warm up the engine and then check to be sure that the fast idle lever is separated from the accelerator lever.
- Remove all of the glow plugs.
- Remove the timing belt upper cover.

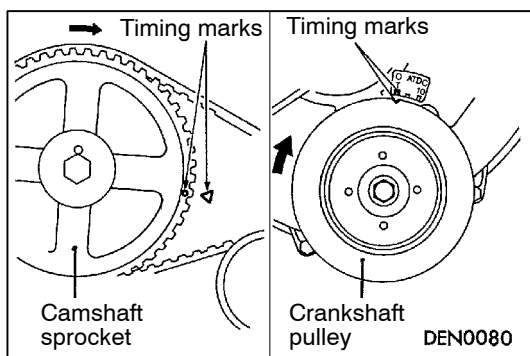

- Align the timing marks of the camshaft sprocket and set the No. 1 cylinder to the top dead centre position.

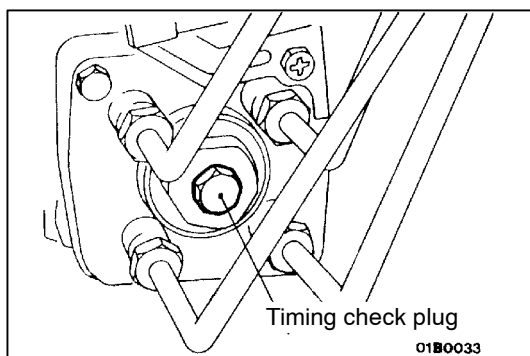

- Remove the timing check plug at the rear of the injection pump.

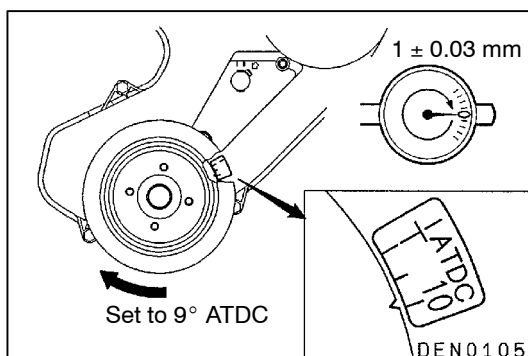
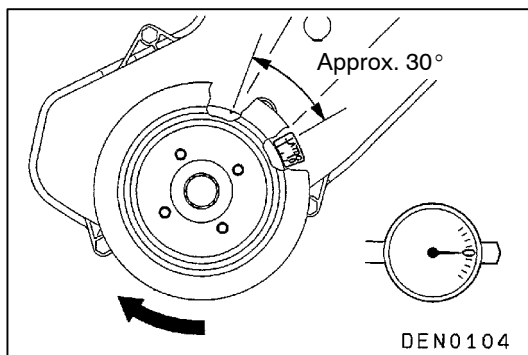
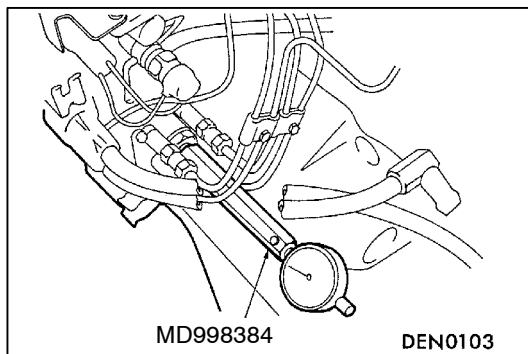
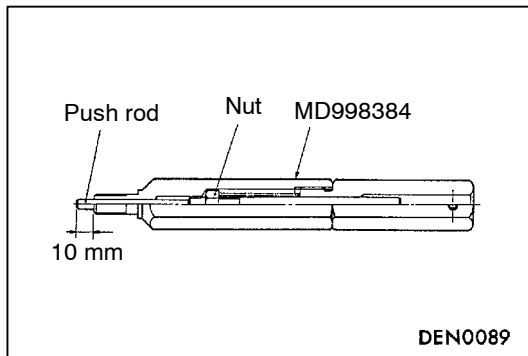

6. Before installation of special tool, make sure that push rod is protruding by 10 mm. Protrusion of push rod can be adjusted with an inner nut.
7. Connect the dial gauge to the special tool.

8. Install the special tool to the check plug at the rear of the injection pump.

9. Turn the crankshaft clockwise to move the No. 1 cylinder approximately 30° before compression top dead centre.
10. Set the needle of the dial gauge to 0.
11. Check that the needle doesn't move even if the crankshaft is turned slightly (2 - 3°) in both clockwise and counterclockwise direction.

NOTE

If the needle moves, the notch is not positioned properly, so once again move the No. 1 cylinder approximately 30° before compression top dead centre.

12. Turn the crankshaft clockwise to align the No. 1 cylinder to 9° ATDC.
13. Check that the value indicated on the dial gauge is at the standard value.

Standard value: 1 ± 0.03 mm

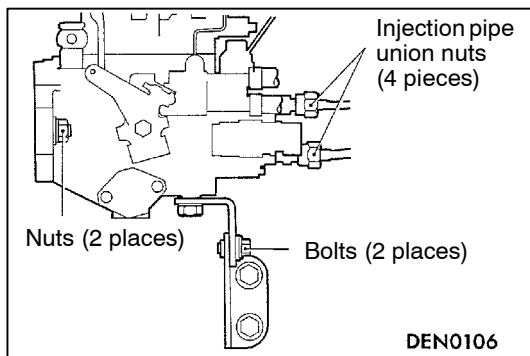

14. If the needle is outside the standard value, adjust the injection timing by the following procedure.

- (1) Loosen the injection pipe union nuts (4 places) on the injection pump. (Do not remove the union nuts.)

Caution

When loosening the nuts, hold the delivery valve holders with a spanner so that they don't turn at the same time.

- (2) Loosen the upper mounting nuts and the lower mounting bolts of the injection pump. (Do not remove the nut and bolt.)

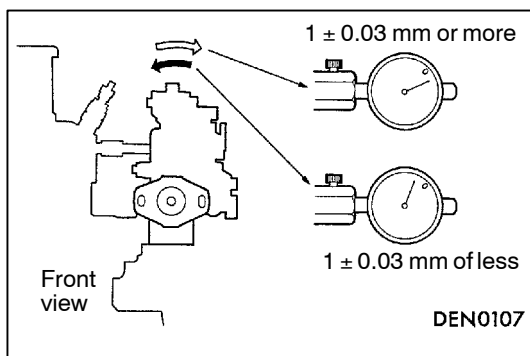

- (3) Tilt the injection pump to the left and right and adjust the needle on the dial gauge so that the display value is uniform.

- (4) Provisionally tighten the mounting nut and bolt of the injection pump.

- (5) Repeat steps 9 - 13 to check if the adjustment has been made correctly.

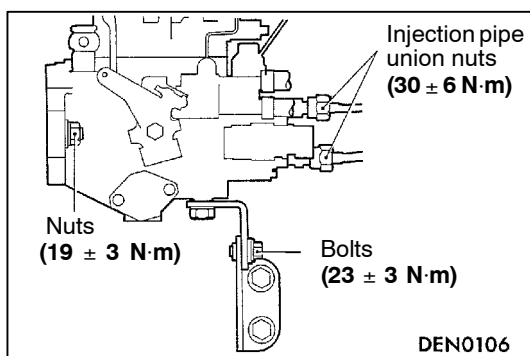

- (6) Tighten the mounting nuts and bolts to the specified torque.

- (7) Tighten the injection pump union nuts to the specified torque.

Caution

When tightening the nuts, hold the delivery valve holders with a spanner so that they don't turn at the same time.

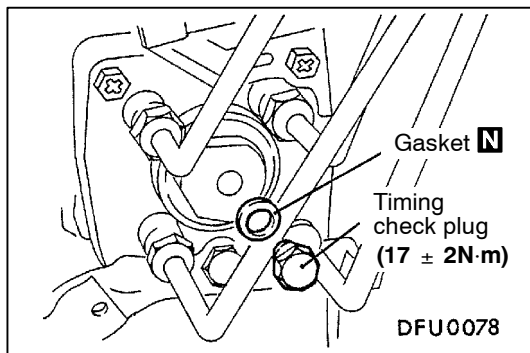

15. Remove the special tool.

16. Install a new gasket to the timing check plug.

17. Tighten the timing check plug to the specified torque.

IDLE SPEED CHECK AND ADJUSTMENT**NOTE**

Check that the injection timing is normal

1. Before inspection, set the vehicle to the pre-inspection condition.

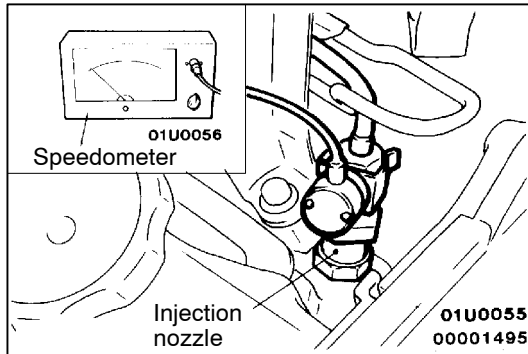

2. Connect the speedometer to the injection nozzle or the injection pipe.

Caution

When the speedometer is connected to the injection pipe, the pipe mounting clamps should all be removed.

3. Start the engine and run it at idle.
4. Check the idle speed.

Standard value: 750 ± 100 r/min

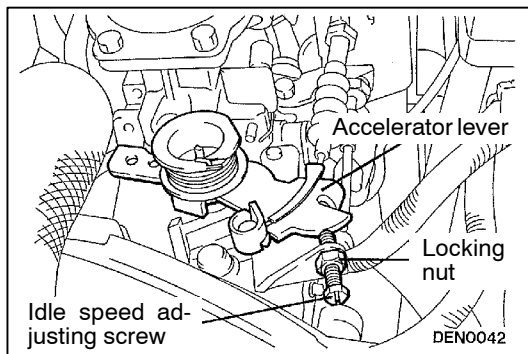

5. If not within the standard value, loosen idle adjusting screw lock nut and adjust the idle speed by rotating adjusting screw. And tighten locking nut.

IDLE-UP MECHANISM CHECK AND ADJUSTMENT-FOR A/C

Refer to GROUP 55 - On-vehicle Service.

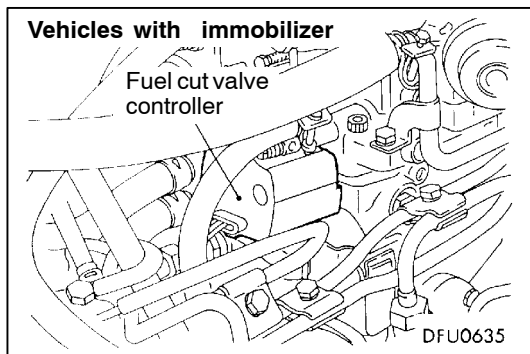
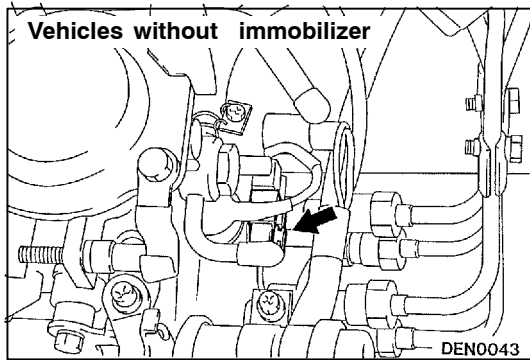

COMPRESSION PRESSURE CHECK

1. Before inspection, check that the engine oil, starter and battery are normal. In addition, set the vehicle to the pre-inspection condition.
2. Remove all of the glow plugs.

3. Disconnect the fuel cut solenoid valve connector. <Vehicles without immobilizer> Disconnect the fuel cut valve controller connector. <Vehicles with immobilizer>

NOTE

Doing this will prevent carrying out fuel injection.

4. Cover the glow plug hole with a shop towel etc., and after the engine has been cranked, check that no foreign material is adhering to the shop towel.

Caution

- (1) **Keep away from the glow plug hole when cranking**
- (2) **If compression is measured with water, oil, fuel, etc., that has come from cracks inside the cylinder, these materials will become heated and will gush out from glow plug hole, which is dangerous.**

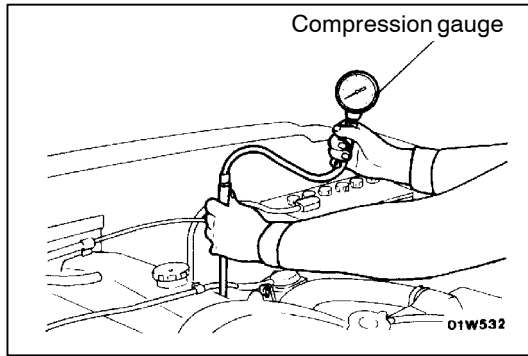

5. Set compression gauge to one of the glow plug holes.
6. Crank the engine and measure the compression pressure.

Standard value (at engine speed of 280 r/min):
3,040 kPa

Limit (at engine speed of 280 r/min): min. 2,256 kPa

7. Measure the compression pressure for all the cylinders, and check that the pressure differences of the cylinders are below the limit.

Limit: max 294 kPa

8. If there is a cylinder with compression or a compression difference that is outside the limit, pour a small amount of engine oil through the glow plug hole, and repeat the operations in steps (6) and (7).
 - (1) If the compression increases after oil is added, the cause of the malfunction is a worn or damaged piston ring and/or cylinder inner surface.
 - (2) If the compression does not rise after oil is added, the cause is a burnt or defective valve seat, or pressure is leaking from the gasket.
9. Connect the fuel cut solenoid valve connector or fuel cut valve controller connector.
10. Install the glow plugs.

Tightening torque: 18 ± 2 N·m

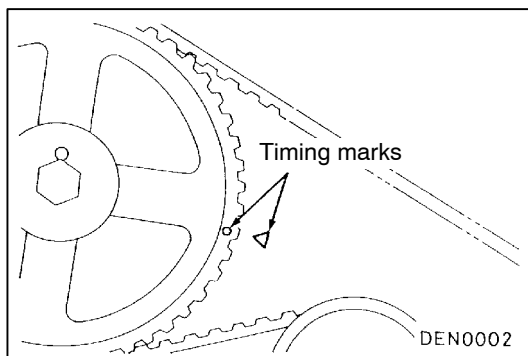

TIMING BELT TENSION ADJUSTMENT

1. Remove the timing belt upper cover.
2. Align the timing mark on the camshaft sprocket with the timing mark on the front upper case to set the No.1 cylinder to top dead centre of its compression stroke.

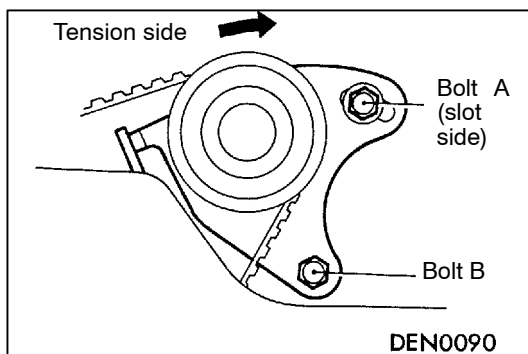

3. Loosen the two tensioner mounting bolts 1 or 2 turns.

NOTE

This will allow the tensioner spring to tension the timing belt automatically.

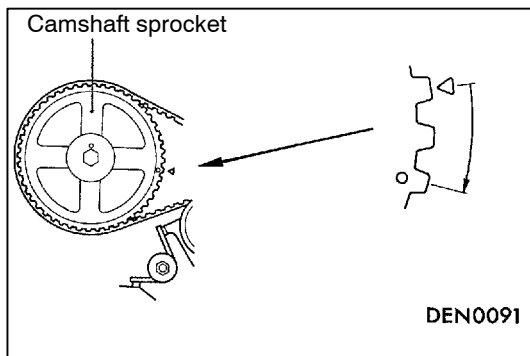

- Turn the crankshaft clockwise and stop at the second teeth of the camshaft sprocket.

Caution

- This will allow the timing belt to be tensioned by a specified amount, so never overturn the crankshaft.
- Never turn the crankshaft counterclockwise.

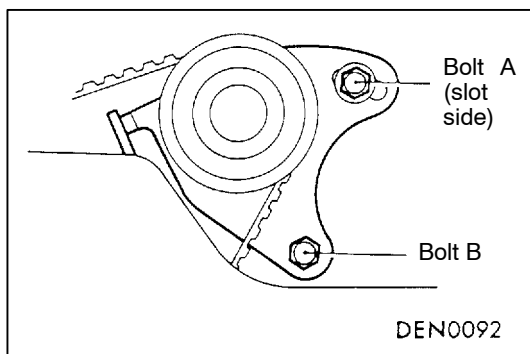

- To prevent the tensioner bracket from being turned together with the crankshaft, first tighten slot-side bolt A to the specified torque, and then tighten bolt B to the specified torque.

Tightening torque: 26 N·m

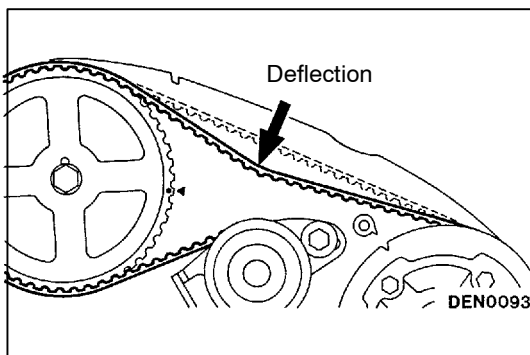

- Turn the crankshaft counterclockwise to align the timing marks. Push down belt at a point halfway with a forefinger to check that deflection of belt is up to standard value.

Standard value: 4.0 - 5.0 mm

- Mount the timing belt upper cover.

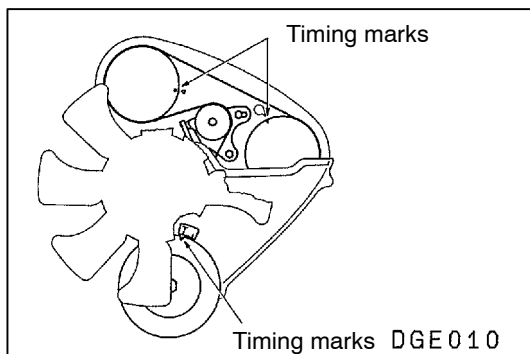
**TIMING BELT B TENSION ADJUSTMENT**

- Remove timing belt upper cover.
- Turn the crankshaft in the clockwise direction and check the timing belt around its entire circumference for abnormalities.
- Align the timing marks on the sprockets with the timing mark on the front upper case.

Caution

When aligning the timing mark, be sure not to turn the crankshaft in the counterclockwise direction as this can cause improper belt tension.

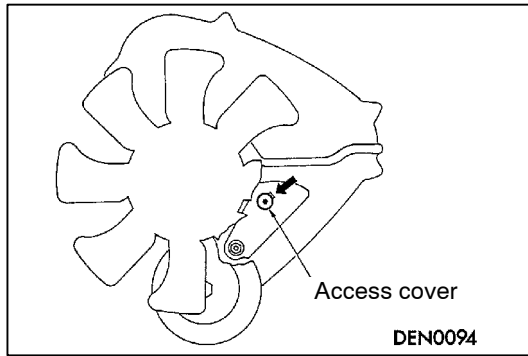

4. Remove the access cover.

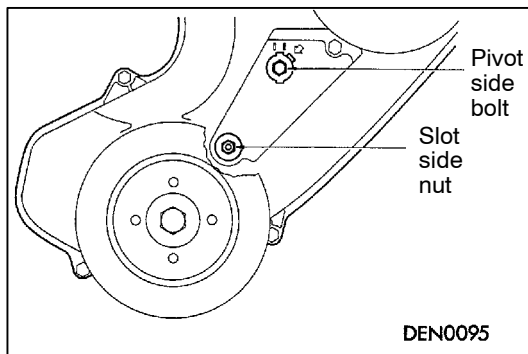

5. Loosen the tensioner pivot side bolt 1 mm and slot side nut 1 or 2 turns.

NOTE

These works will allow the tensioner spring to tension timing belt B automatically.

6. First tighten tensioner slot side nut, and then tighten pivot side bolt to the specified torque.

Tightening torque:

Pivot side bolt 24 ± 4 N·m

Slot side nut 23 ± 3 N·m

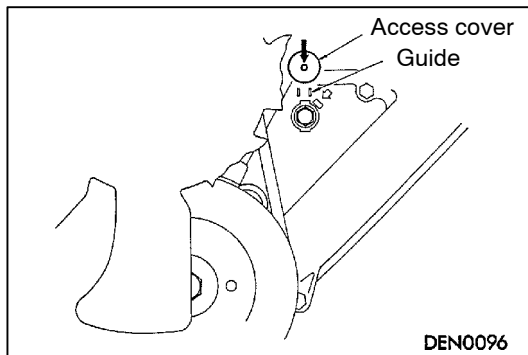

7. Install the access cover while sliding the front lower cover down along the two guides.
8. Install the timing belt upper cover.

OIL PAN AND OIL SCREEN

REMOVAL AND INSTALLATION

Pre-removal and Post-installation Operation

- Skid Plate and Under Cover Removal and Installation
- Engine Oil Draining and Supplying (Refer to GROUP 12 - On-vehicle Service.)
- Differential Gear Oil Draining and Supplying (Refer to GROUP 26 - On-vehicle Service.)
- Front Differential and No.2 Crossmember Assembly Removal and Installation (Refer to GROUP 11A - Oil Pan and Oil Screen.)

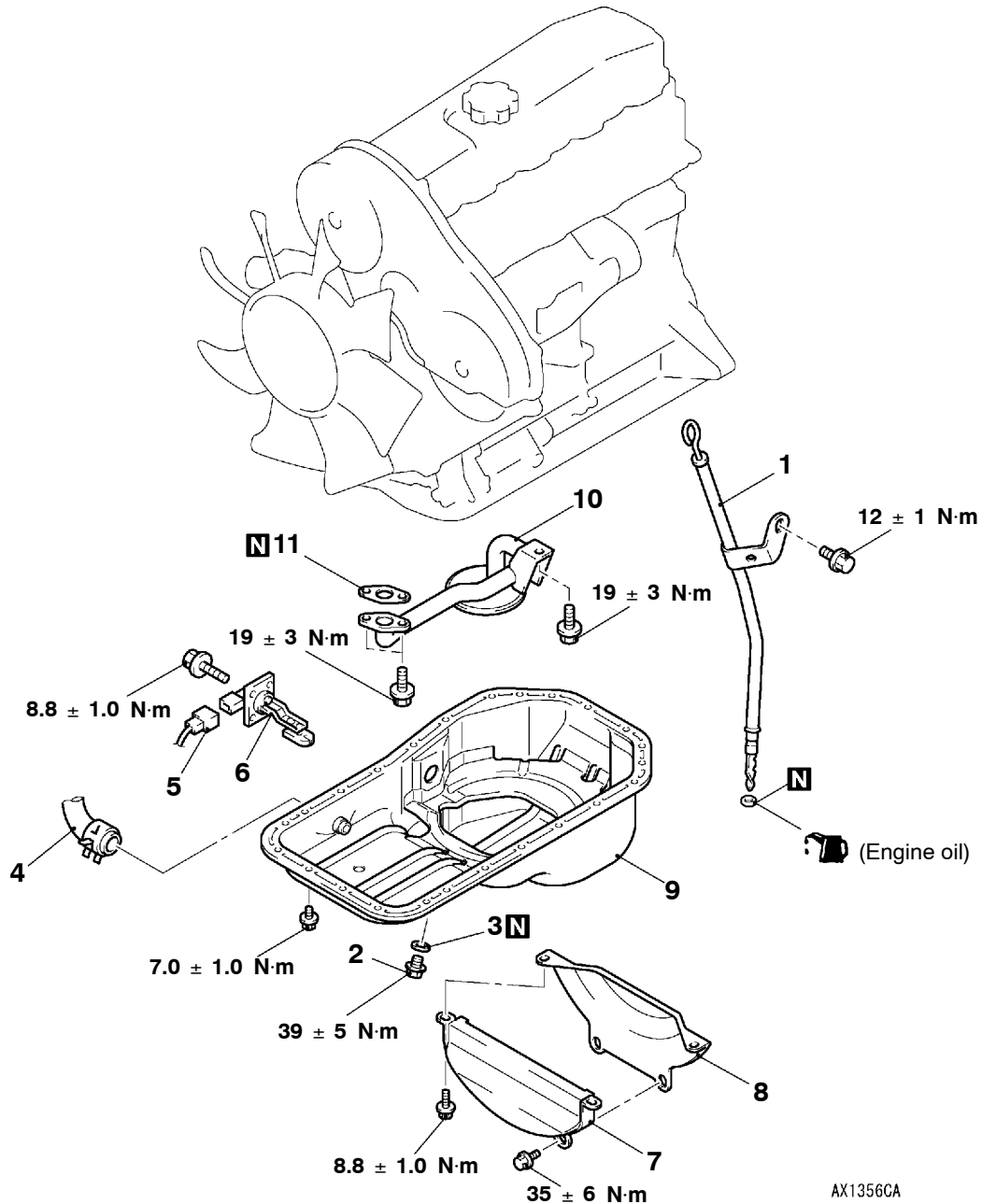
**Removal steps**

- | | |
|---|---|
| <p>▶B◀</p> <ol style="list-style-type: none"> 1. Engine oil level gauge and guide assembly 2. Drain plug 3. Drain plug gasket 4. Alternator vacuum pump oil return hose connection 5. Oil level sensor connector | <p>◀A▶ ▶A▶</p> <ol style="list-style-type: none"> 6. Oil level sensor 7. Space rubber 8. Bell housing cover 9. Oil pan 10. Oil screen 11. Oil screen gasket |
|---|---|

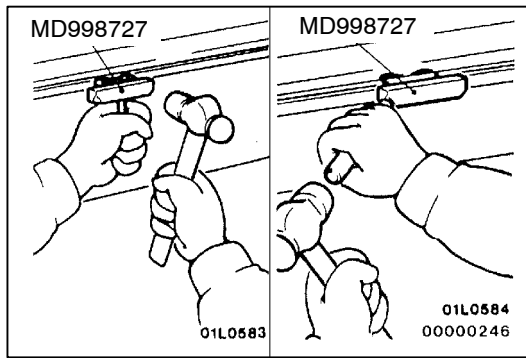
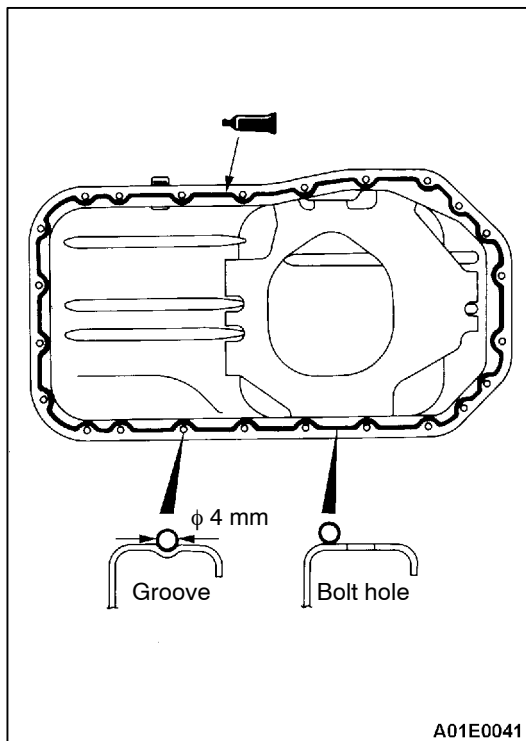
**REMOVAL SERVICE POINT****◀A▶ OIL PAN REMOVAL****INSTALLATION SERVICE POINTS****▶A◀ OIL PAN INSTALLATION**

1. Remove sealant from oil pan and cylinder block mating surfaces.
2. Degrease the sealant-coated surface and the engine mating surface.
3. Apply a continuous bead of the specified sealant to the oil pan mating surface as shown.

Specified sealant:

MITSUBISHI GENUINE PART No. MD970389 or equivalent

NOTE

The sealant should be applied in a continuous bead approximately 4 mm in diameter.

4. Assemble oil pan to cylinder block within 15 minutes after applying the sealant.

Caution

After installing the oil pan, wait at least 1 hour before starting the engine.

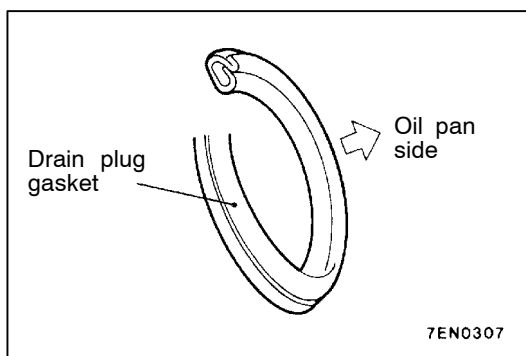
**▶B◀ DRAIN PLUG GASKET INSTALLATION**

Install a new gasket in the direction so that it faces as shown in the illustration.

INSPECTION

- Check oil pan for cracks.
- Check oil pan sealant-coated surface for damage and deformation.
- Check oil screen for cracked, clogged or damaged wire net and pipe.

TIMING BELT AND TIMING BELT B

REMOVAL AND INSTALLATION

Post-installation Operation

Drive Belt Tension Check and Adjustment
(Refer to P.11B-5.)

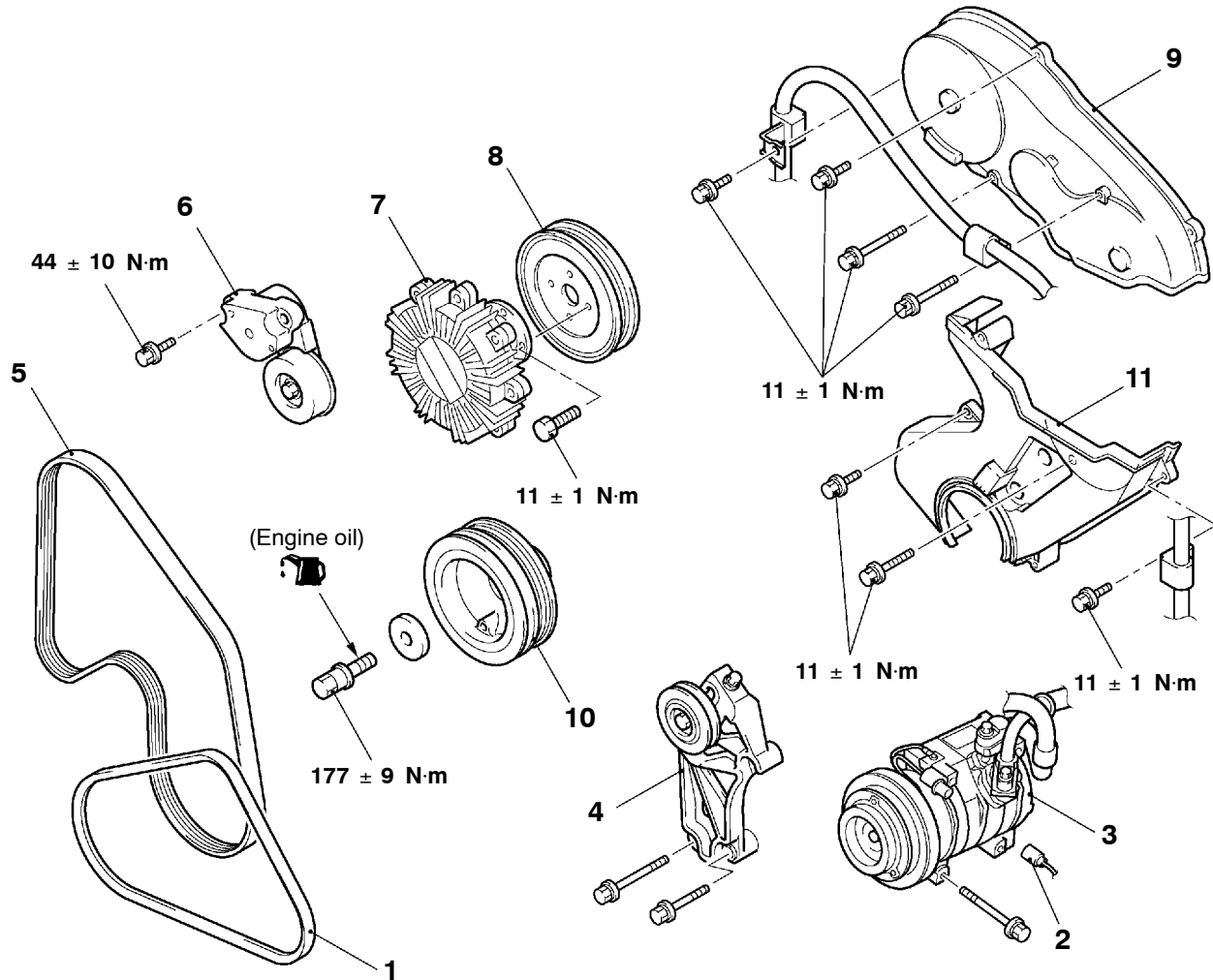

AY0085CA

Removal steps

- Radiator upper shroud (Refer to GROUP 14.)
- ◀A▶ 1. A/C compressor drive belt <Vehicles with A/C>
- ◀B▶ 2. A/C compressor connector <Vehicles with A/C>
3. A/C compressor <Vehicles with A/C>
4. Tension pulley and tension pulley bracket assembly <Vehicles with A/C>
- ◀C▶ 5. Alternator and power steering oil pump drive belt
6. Auto-tensioner
7. Fan Clutch
8. Water pump pulley
- ◀D▶ ▶C▶ 9. Timing belt front upper cover
- ▶C▶ 10. Crankshaft pulley
- ▶C▶ 11. Timing belt front lower cover
- Cooling fan (Refer to GROUP 14.)

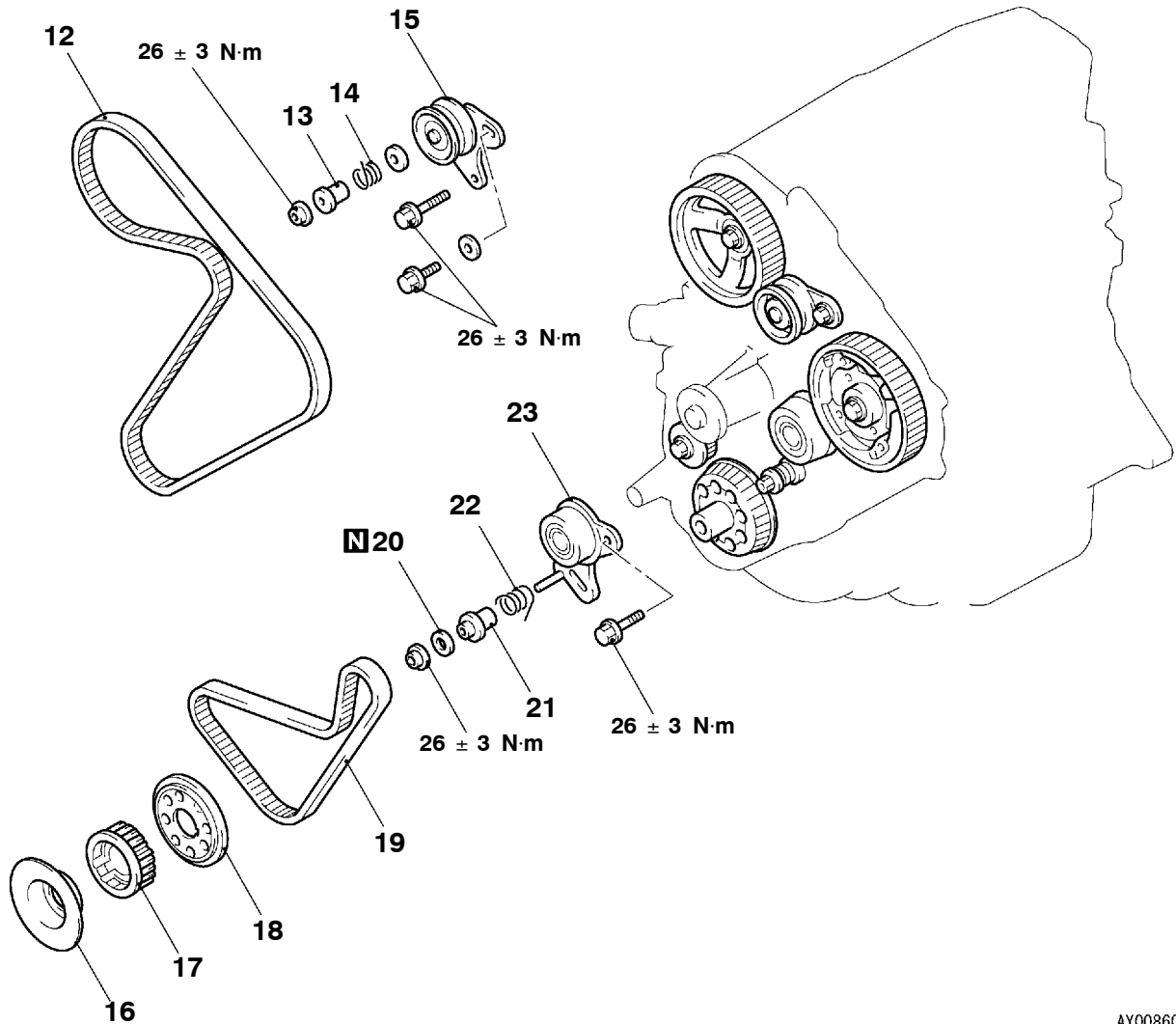

AY0086CA

- ◀E▶ ▶B▶
- 12. Timing belt
 - 13. Tensioner spacer
 - 14. Tensioner spring
 - 15. Timing belt tensioner
 - 16. Front flange
 - 17. Crankshaft sprocket

- ◀F▶ ▶A▶
- 18. Flange
 - 19. Timing belt B
 - 20. Gasket
 - 21. Tensioner spacer B
 - 22. Tensioner spring B
 - 23. Timing belt tensioner B

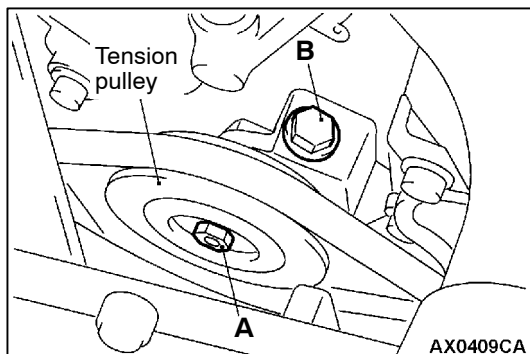

REMOVAL SERVICE POINTS

◀A▶ **A/C COMPRESSOR DRIVE BELT REMOVAL**

1. Loosen the tension pulley securing bolt A.
2. Loosen the adjusting bolt B to remove the belt.

Caution

To reuse the drive belt, mark its running direction (clockwise direction) on the belt back side with a chalk.

◀B▶ A/C COMPRESSOR REMOVAL

1. Remove the A/C compressor from the bracket with its refrigerant hoses still attached.
2. Suspend the A/C compressor with a cord out of the way.

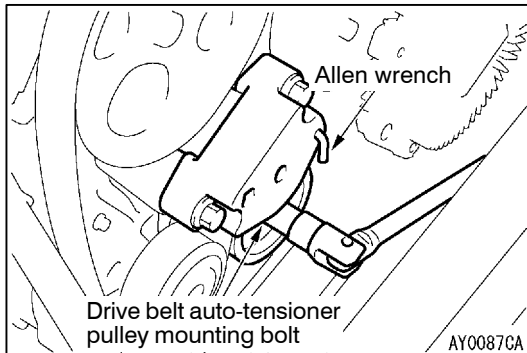
**◀C▶ ALTERNATOR AND POWER STEERING PUMP DRIVE BELT REMOVAL**

The following operations will be needed due to the introduction of the serpentine drive system with the drive belt auto tensioner.

1. Locate a ring spanner onto the drive belt auto-tensioner pulley mounting bolt, and move the tensioner clockwise until it touches the stopper.
2. Hold the tensioner by inserting an Allen wrench as shown, and remove the drive belt.

Caution

To reuse the drive belt, mark its running direction (clockwise direction) on the belt back side with a chalk.

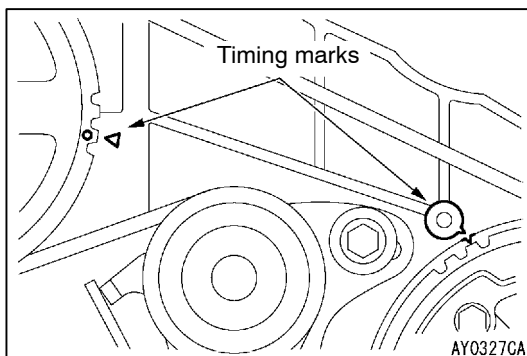
**◀D▶ CRANKSHAFT PULLEY REMOVAL**

1. Turn the crankshaft clockwise, align the timing marks to set No.1 cylinder to TDC of its compression stroke.

Caution

Never turn the crankshaft anticlockwise.

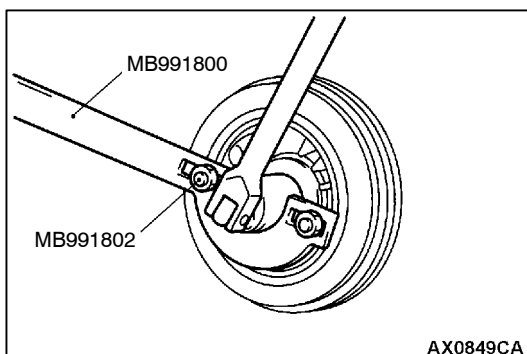

2. Use the special tool to keep crankshaft from turning and remove the bolts.

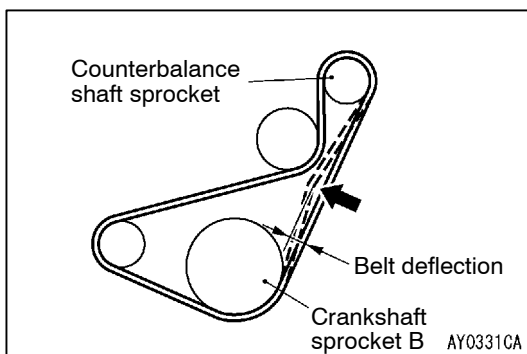
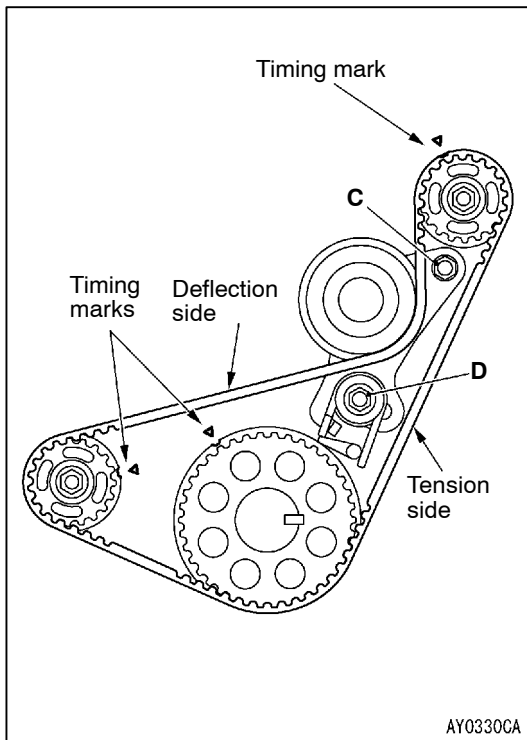
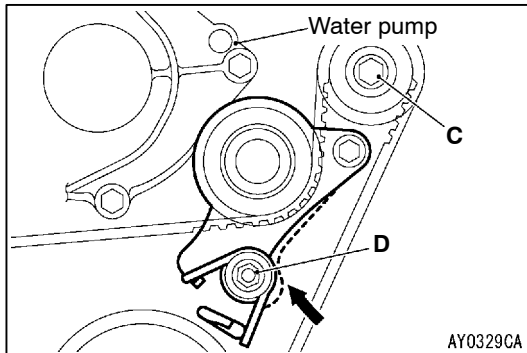
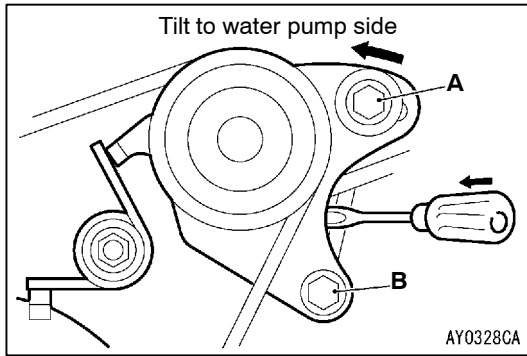

◀E▶ TIMING BELT REMOVAL

1. When reinstalling timing belt, mark an arrow at the belt to show rotation direction.
2. Loosen the tensioner mounting bolt A and B.
3. Push timing belt tensioner to water pump side and tighten the tensioner mounting bolt A and B. Secure so that tensioner will not move back.

◀F▶ TIMING BELT B REMOVAL

1. When reinstalling timing belt B, mark an arrow at the belt to show rotation direction.
2. Loosen the tensioner mounting bolt C and nut D.
3. Push timing belt tensioner to water pump side and tighten the tensioner mounting bolt C and nut D. Secure so that tensioner will not move back.

INSTALLATION SERVICE POINTS

▶A◀ TIMING BELT B INSTALLATION

1. Align the timing marks of the 3 sprockets.
2. When reusing timing belt B, make sure the arrow mark is pointing in the same direction as when the belt was removed.
3. Install timing belt B and make sure there is no deflection on the tension side.
4. Press the deflection side of timing belt B with the hand and fully stretch the tensioner side.
5. Make sure that the timing marks are aligned.
6. Loosen the tensioner mounting bolt and nut so that only the pressure of the spring is applied to timing belt B.
7. Tighten the tensioner mounting bolt C and nut D, tightening the nut first. If the bolt is tightened first, the tensioner will move and tension the belt.

Tightening torque: 26 ± 3 N·m

8. Press in the direction of the arrow in the figure with the index finger to check the amount of deflection.

Standard value: 4 - 5 mm

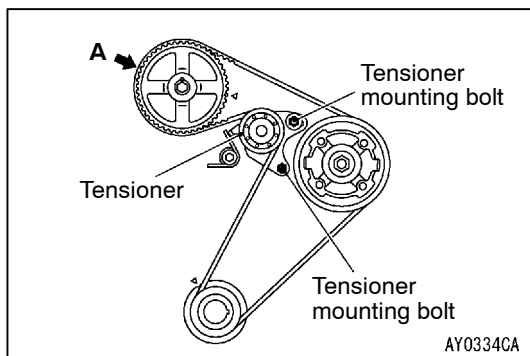
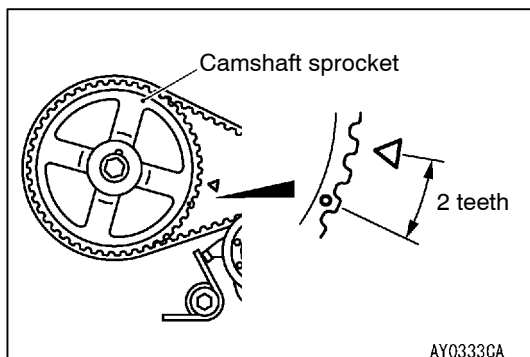
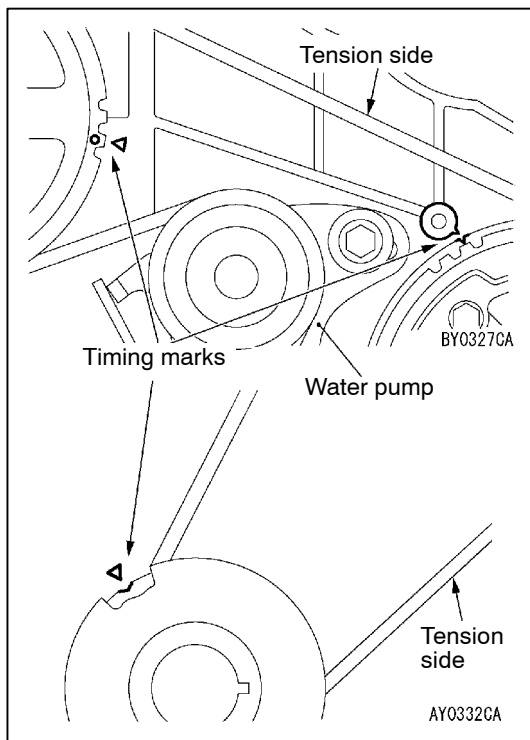

►B◄ TIMING BELT INSTALLATION

1. Align the timing marks of the 3 sprockets.
2. When reusing timing belt, make sure the arrow mark is pointing in the same direction as when the belt was removed.
3. Install the timing belt to the crankshaft sprocket, to injection pump sprocket, to tensioner and to camshaft sprocket in that order. Being careful not to allow deflection on the tension side of the timing belt.

Caution

- (1) Engage the belt on the various sprockets while maintaining tension on the belt of tension side.
- (2) Align the injection pump sprocket with the timing mark, hold the sprocket so that it does not turn and engage the belt.
4. Loosen the tensioner mounting bolts and apply tension with the spring.

5. Turn the crankshaft clockwise and stop at the second lobe of the camshaft sprocket.

Caution

- (1) When turning the crankshaft in item (5), strictly observe the specified amount of rotation (2 teeth on the camshaft sprocket) in order to apply a constant force to the tension side of the belt.
- (2) Do not turn the crankshaft counterclockwise.
- (3) Do not touch the belt during adjustment.
6. Make sure that the part indicated by arrow A does not float upward.
7. Tighten the tensioner mounting bolts, starting with the bolt in the elongated hole. If the lower bolt is tightened first, belt tension will become too tight.
8. Turn the crankshaft anticlockwise and align the timing mark. Next, make sure that the timing marks of all sprockets are aligned.

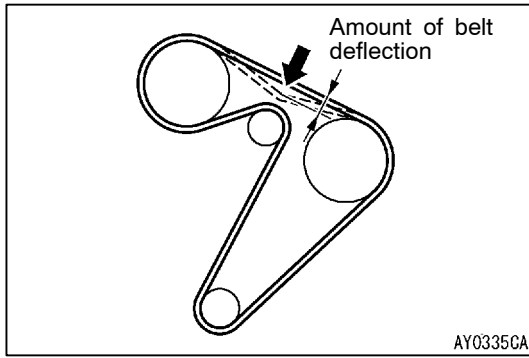

- Press on the center of the bolt with an index finger to check the amount of deflection.

Standard value: 4 - 5 mm

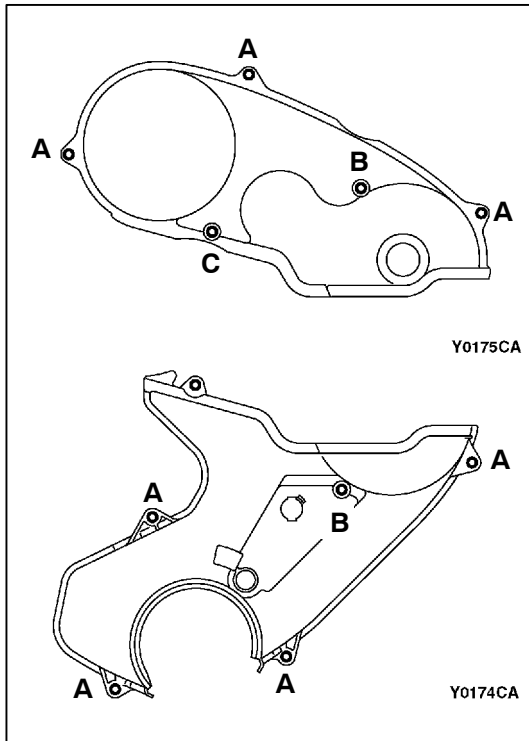

▶◀ TIMING BELT FRONT LOWER COVER/TIMING BELT FRONT UPPER COVER INSTALLATION

Install the bolts to the timing belt cover at the shown positions.

Name	Symbols	Size mm (d × l)
Flange bolt	A	6 × 22
	B	6 × 50
	C	6 × 60

d=Nominal diameter
l=Nominal length

CRANKSHAFT OIL SEAL REMOVAL AND INSTALLATION

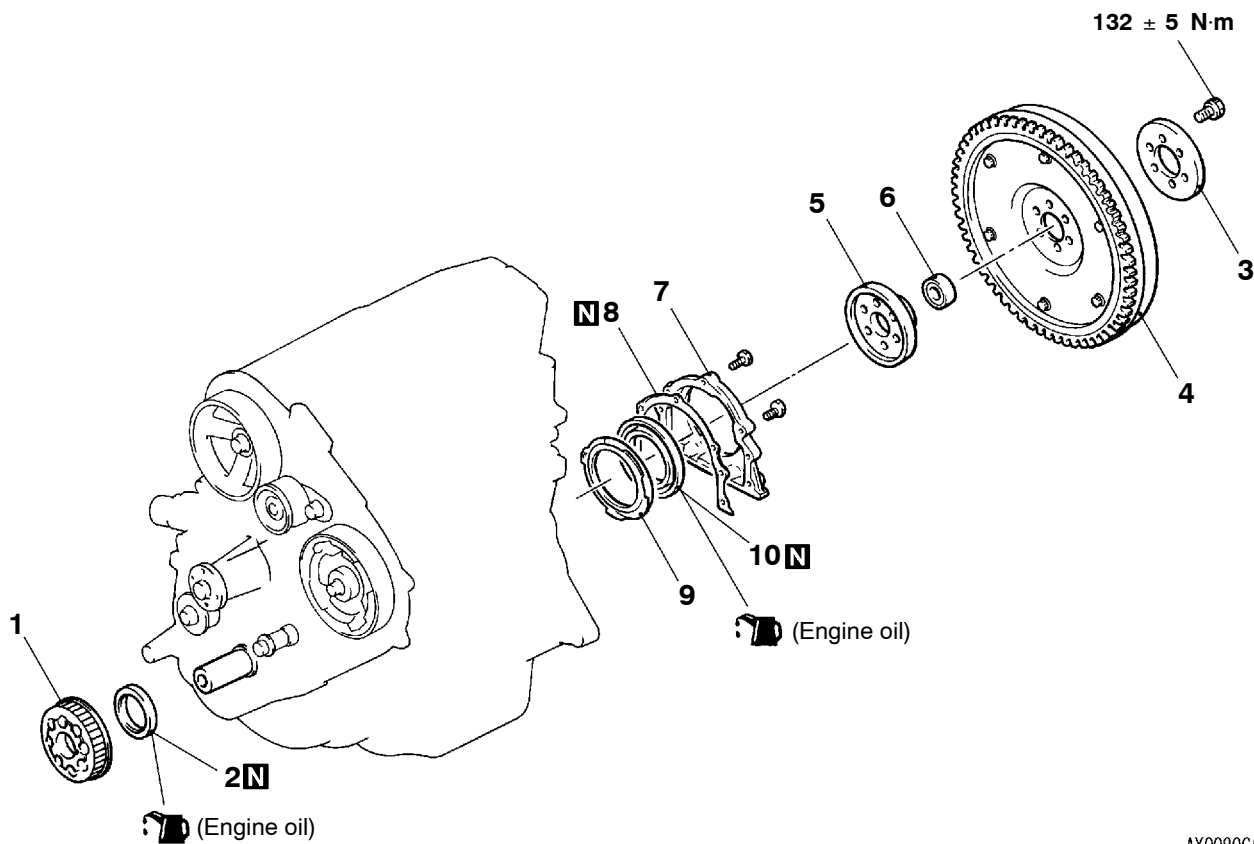

AY0090CA

Crankshaft front oil seal removal steps

- Timing belt and timing belt B removal and installation (Refer to P.11B-19.)

1. Crankshaft sprocket B
2. Crankshaft front oil seal



Crankshaft rear oil seal removal steps

- Transmission assembly (Refer to GROUP 22.)

3. Adapter plate
4. Flywheel assembly
5. Crankshaft adaptor
6. Ball bearing
7. Oil seal case
8. Gasket
9. Oil separator
10. Crankshaft rear oil seal

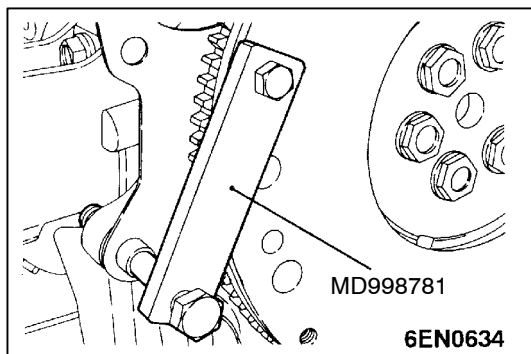

REMOVAL SERVICE POINTS

◀A▶ FLYWHEEL ASSEMBLY REMOVAL

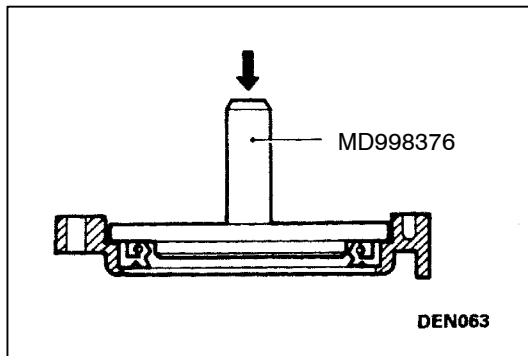
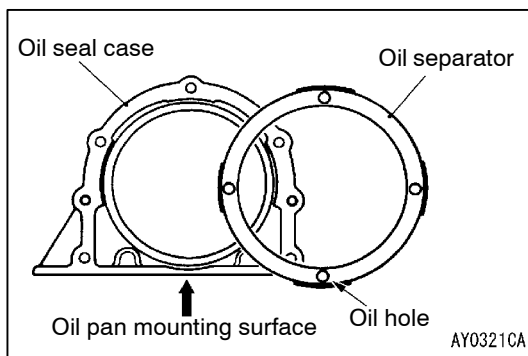
**INSTALLATION SERVICE POINTS****►A◄ CRANKSHAFT REAR OIL SEAL INSTALLATION****►B◄ OIL SEPARATOR INSTALLATION**

Install the oil separator in such a way that its oil hole come at the case bottom (indicated by an arrow in the illustration).

►C◄ FLYWHEEL ASSEMBLY INSTALLATION

Use the special tool in the same way as during removal to stop the flywheel assembly from turning, and then tighten the bolt to the specified torque.

Tightening torque: 132 ± 5 N·m

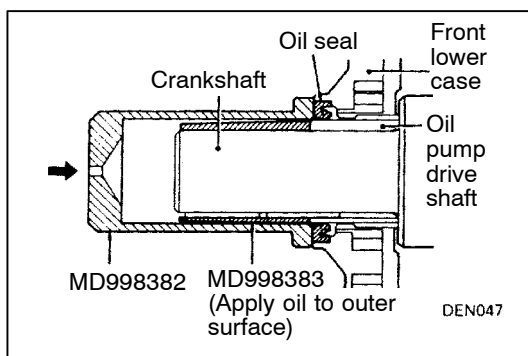
**►D◄ CRANKSHAFT FRONT OIL SEAL INSTALLATION**

Apply engine oil to the outside of the special tool (MD998383) and to the oil seal lip, and use the special tool to press-fit the oil seal.

CAMSHAFT AND CAMSHAFT OIL SEAL

REMOVAL AND INSTALLATION

Pre-removal and Post-installation Operation

- Air Pipe and Air Intake Hose Removal and Installation (Refer to GROUP 15 - Intake Manifold and Exhaust manifold, Turbocharger <4D5>.)

 Apply engine oil to all moving parts during installation.

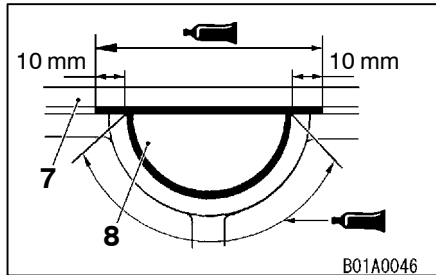

B01A0046

Sealant:
3M ATD Part No. 8660 or equivalent

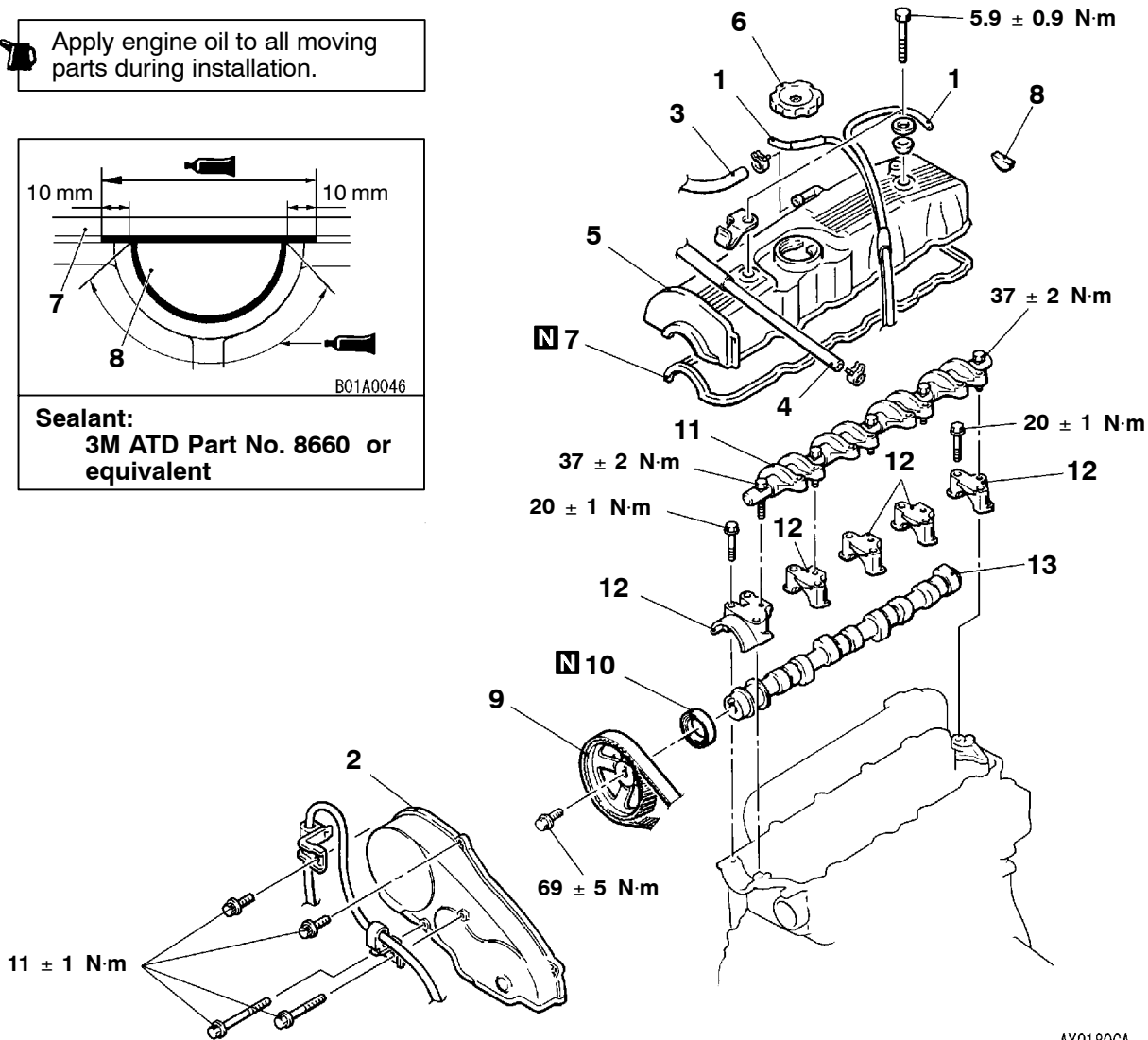

AY0180CA

Camshaft removal steps

- ▶E◀ 1. Vacuum hose connection
- ▶E◀ 2. Timing belt front upper cover
- ▶E◀ 3. Breather hose connection
- ▶E◀ 4. Boost hose connection
- ▶E◀ 5. Rocker cover
- ▶E◀ 6. Oil filler cap
- ▶E◀ 7. Rocker cover gasket
- ▶E◀ 8. Semi-circular packing
- ▶E◀ • Valve clearance adjustment (Refer to P.11B-8.)

Camshaft oil seal removal steps

- ◀A▶ ▶E◀ 2. Timing belt upper cover assembly
- ◀A▶ ▶D◀ 9. Camshaft sprocket
- ◀A▶ ▶C◀ 10. Camshaft oil seal

- ◀A▶ ▶D◀ 9. Camshaft sprocket
- ◀B▶ ▶C◀ 10. Camshaft oil seal
- ◀B▶ ▶B◀ 11. Rocker arm and shaft assembly
- ◀B▶ ▶A◀ 12. Camshaft bearing cap
- ▶A▶ 13. Camshaft

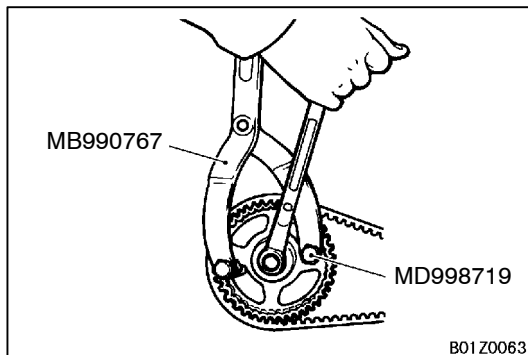
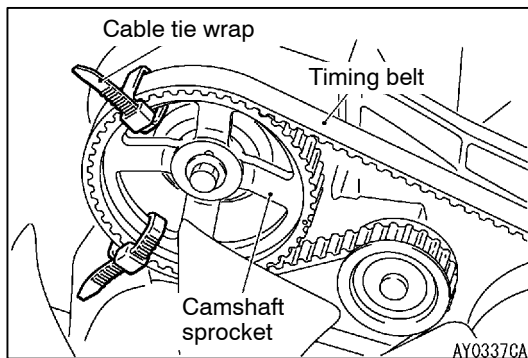
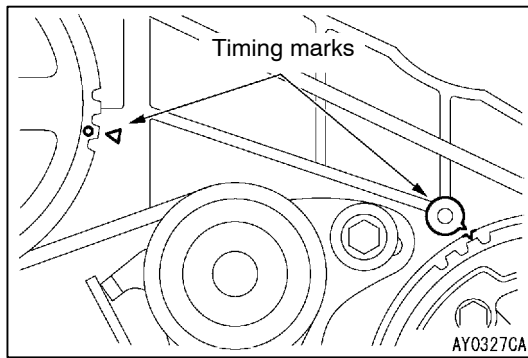

REMOVAL SERVICE POINTS

◀A▶ CAMSHAFT SPROCKET REMOVAL

1. Turn the crankshaft clockwise, align the timing marks to set No.1 cylinder to TDC of its compression stroke.

Caution

Never turn the crankshaft anticlockwise.

2. Tie the camshaft sprocket and timing belt together with a cable tie wrap so that timing mark is not maladjusted.

3. Use the special tool to stop the camshaft sprocket from turning, and then remove the camshaft sprocket with the timing belt still attached.

Caution

Do not rotate crankshaft after removing camshaft sprocket.

◀B▶ ROCKER ARM AND SHAFT ASSEMBLY REMOVAL

Loosen the rocker arm and shaft assembly mounting bolt, and then remove the rocker arm and shaft assembly with the bolt still attached.

Caution

Never disassemble the rocker arm and shaft assembly.

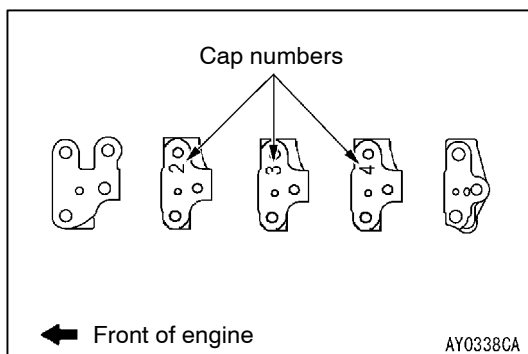

INSTALLATION SERVICE POINTS

▶A▶ CAMSHAFT BEARING CAP INSTALLATION

The cap numbers are embossed on the top surface of the bearing caps, so install in the order of the numbers. However, no numbers are embossed on bearing caps 1 and 5.

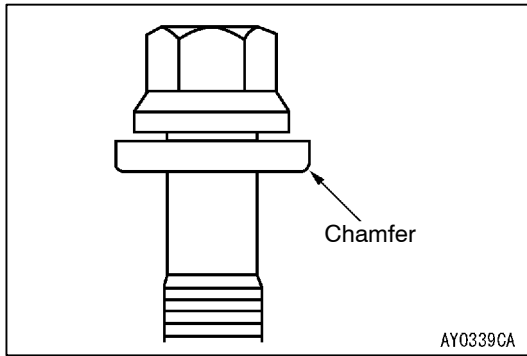

►B◄ ROCKER ARM AND SHAFT ASSEMBLY INSTALLATION

1. Install the rocker arm and shaft assembly to the bearing caps.
2. Set the washer so that it faces in the direction shown in the illustration, and then install the bolt.

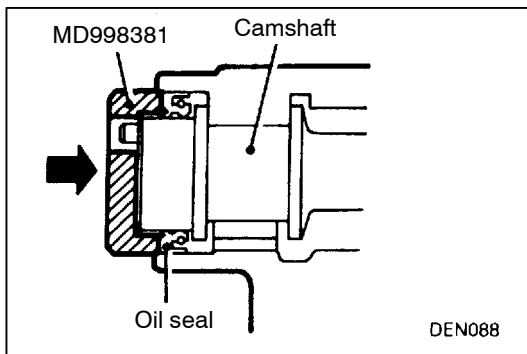

►C◄ CAMSHAFT OIL SEAL INSTALLATION

1. Apply a small amount of engine oil to the entire circumference of the oil seal lip and camshaft.
2. Use the special tool to tap in the oil seal.

NOTE

The oil seal should be tapped in until the distance from the end of the camshaft to the end of the oil seal is as shown in the illustration.

►D◄ CAMSHAFT SPROCKET INSTALLATION

1. Use the special tool in the same way as during removal to stop the camshaft sprocket from turning, and then tighten the bolt to the specified torque.

Tightening torque: 69 ± 5 N·m

2. Remove the cord which binds the camshaft sprocket and timing belt.

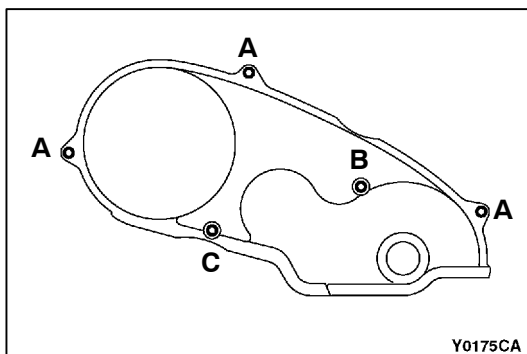

►E◄ TIMING BELT FRONT UPPER COVER INSTALLATION

Install the bolts to the timing timing belt front upper cover at the shown positions.

Name	Symbols	Size mm (d × l)
Flange bolt	A	6 × 22
	B	6 × 50
	C	6 × 60

d=Nominal diameter

l=Nominal length

CYLINDER HEAD GASKET

REMOVAL AND INSTALLATION

Pre-removal and Post-installation Operation

- Cooling Fan and Fan Clutch Assembly Removal and Installation (Refer to GROUP 14.)
- Intake Manifold Removal and Installation (Refer to GROUP15 - Intake Manifold and Exhaust Manifold, Turbocharger <4D5>.)
- Engine Oil Check and Refill (Refer to GROUP 12 - On-vehicle Service.) <Post-installation operation>
- Fuel Line Air-bleeding (Refer to GROUP 13B - On-vehicle Service.) <Post-installation operation>
- Timing Belt Removal and Installation (Refer to P.11B-19.)

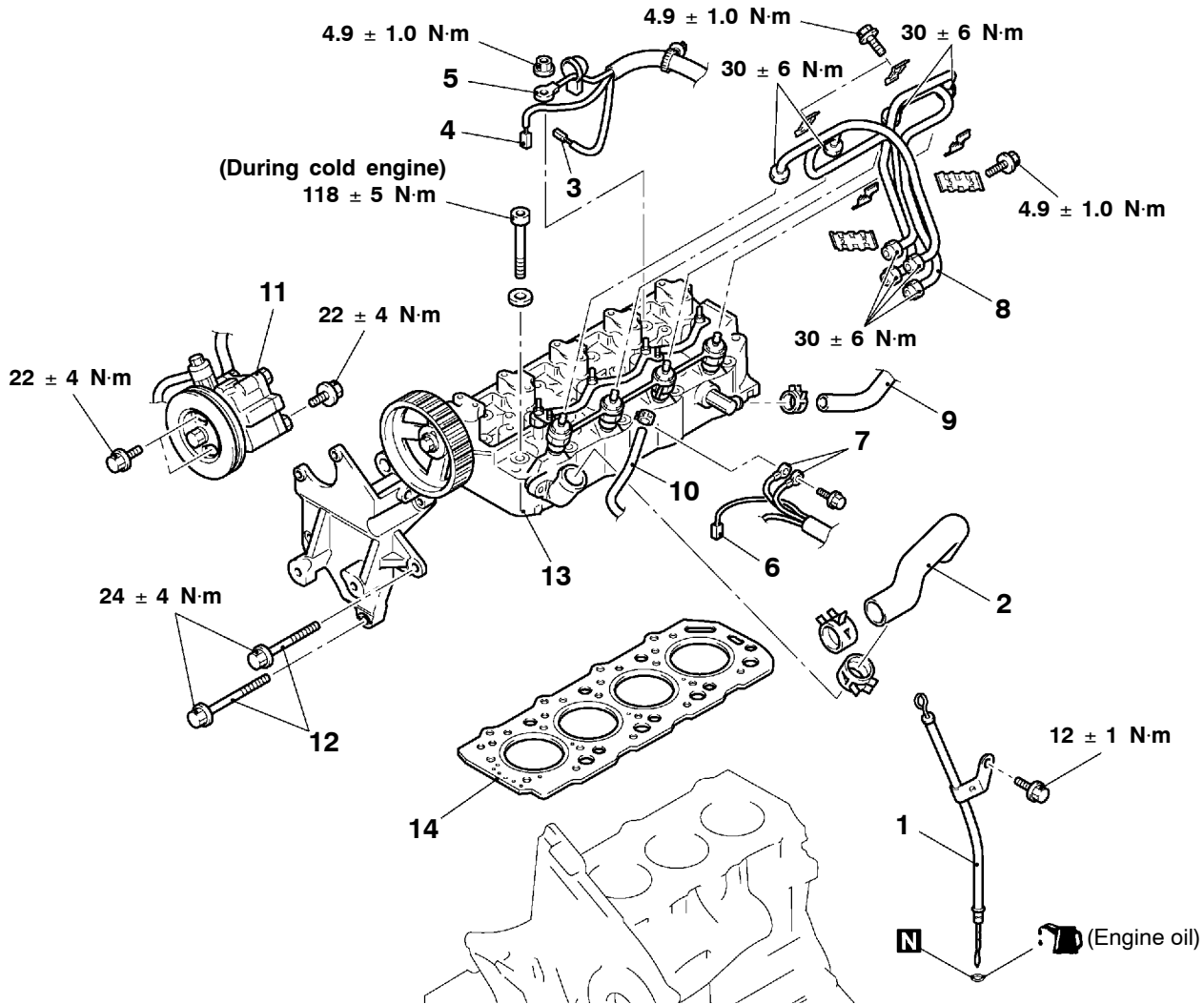

AY0200CA

Removal steps

- | | |
|---|---|
| <p>◀A▶ ▶D▶</p> <ol style="list-style-type: none"> 1. Oil level gauge guide and oil level gauge assembly 2. Radiator upper hose ● Rocker cover (Refer to P.11B-27.) 3. Engine coolant temperature switch connector (for A/C compressor control.) 4. Engine coolant temperature switch connector (for condenser fan control.) 5. Glow plug connector 6. Engine coolant temperature gauge unit and sensor connector | <p>◀B▶ ▶C▶</p> <p>◀C▶</p> <p>◀D▶ ▶B▶ ▶A▶</p> <ol style="list-style-type: none"> 7. Earth cable connection 8. Fuel injection pipe 9. Heater hose connection 10. Fuel hose connection ● Water pipe assembly C (Refer to GROUP 14.) 11. Power steering oil pump assembly 12. Power steering oil pump bracket bolt 13. Cylinder head assembly 14. Cylinder head gasket |
|---|---|

REMOVAL SERVICE POINTS**◀A▶ RADIATOR UPPER HOSE DISCONNECTION**

After making mating marks on the radiator upper hose and the hose clamp, disconnect the radiator upper hose.

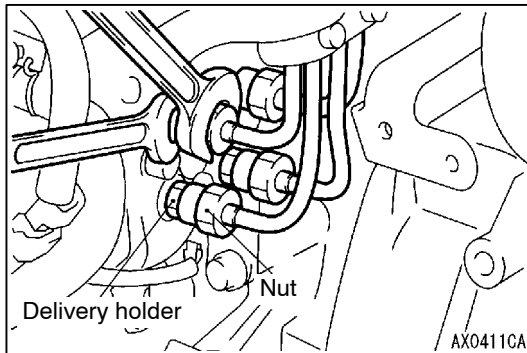
**◀B▶ FUEL INJECTION PIPE REMOVAL**

When loosening nuts at both ends of injection pipe, hold the delivery holder (for pump side) and the injection nozzle assembly (for nozzle side) with wrench and loosen nut.

Caution

After disconnecting the injection pipe, plug the opening so that no foreign particles get inside the pump or into the injection nozzle.

◀C▶ POWER STEERING OIL PUMP REMOVAL

Remove the power steering oil pump from the bracket with the hose attached.

NOTE

Place the removed power steering oil pump in a place where it will not be a hindrance when removing and installing the engine assembly, and tie it with a cord.

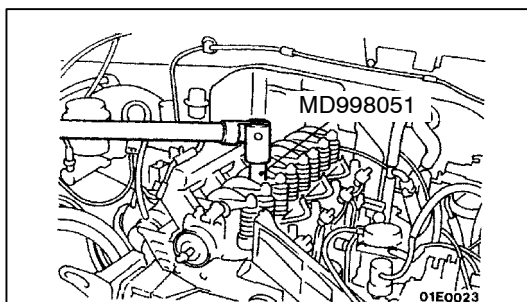
**◀D▶ CYLINDER HEAD ASSEMBLY REMOVAL**

Use the special tool to loosen the cylinder head bolts in the shown sequence progressively, and then remove the cylinder head bolts.

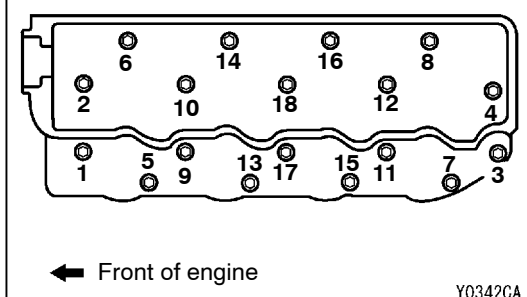

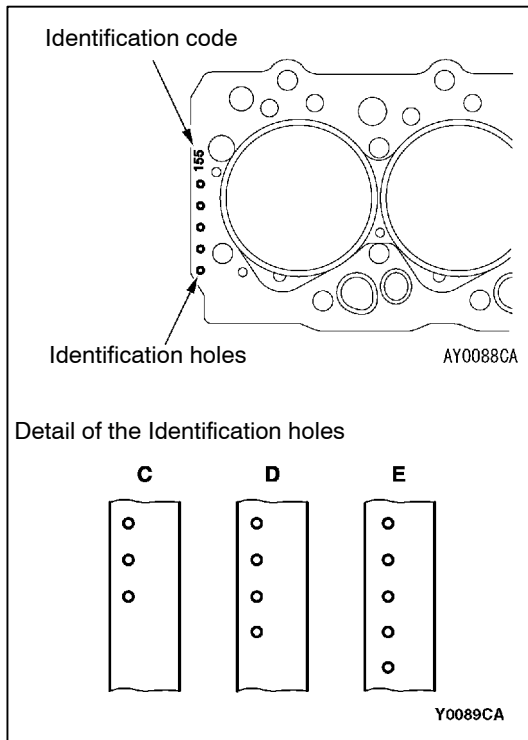

INSTALLATION SERVICE POINTS

►A◀ CYLINDER HEAD GASKET INSTALLATION

To replace the cylinder head gasket only, select a gasket of correct specification according to the table below.

Identification holes specification	Identification code specification	Part number
C (Thickness after tightening the bolts 1.45 mm)	145	MD302891
D (Thickness after tightening the bolts 1.50 mm)	150	MD302892
E (Thickness after tightening the bolts 1.55 mm)	155	MD302893

Caution

The thickness of the original cylinder head gasket is selected according to the protrusion amount of the piston. Therefore, if the piston or the connecting rod is replaced, the protrusion amount may be changed. Always select a correct gasket by measuring the protrusion amount. (For details, refer to the Engine Workshop Manual.)

►B◀ CYLINDER HEAD INSTALLATION

1. Select a cylinder head gasket of correct specification.
2. Clean the cylinder head assembly and the cylinder block mating surfaces with a scraper or a wire brush.

Caution

Do not allow foreign material to enter the engine coolant or oil passages and the cylinder.

3. Install the cylinder head bolt washer to the cylinder head bolt so that the washer chamfered side faces as shown.

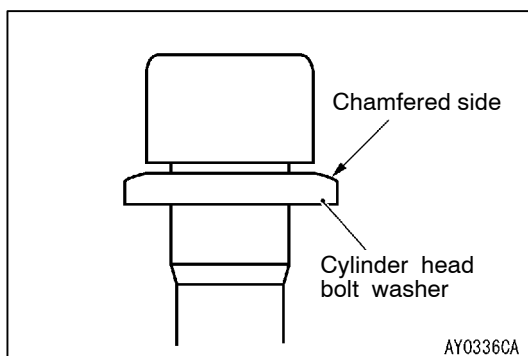

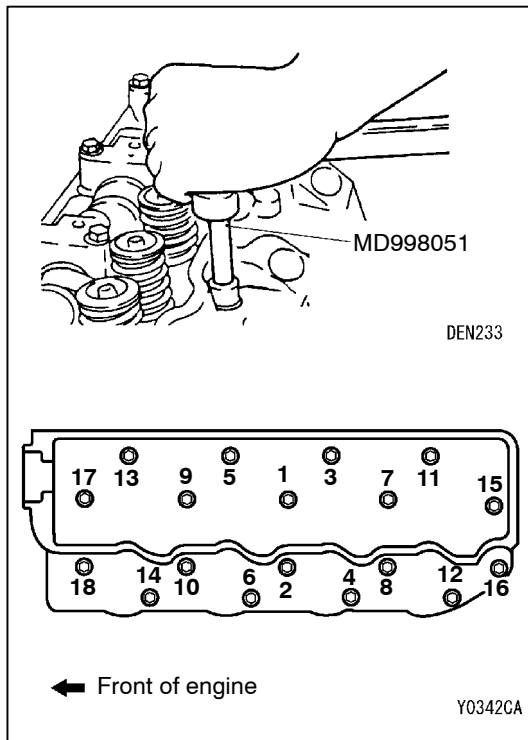

- Use the special tool to tighten the cylinder head bolts in the shown sequence progressively, and then install the cylinder head bolts.

Tightening torque : 132 ± 5 N·m (During cold engine)

►C◄ RADIATOR UPPER HOSE CONNECTION

To reuse the radiator upper hose, align the mating marks that were made during removal, and then install the hose clamp.

►D◄ FUEL INJECTION PIPE INSTALLATION

When tightening the nuts at both ends of the fuel injection pipe, hold the delivery holder (for pump side) and the injection nozzle assembly (for nozzle side) with a wrench, and tighten the nuts to the specified torque.

Tightening torque: 30 ± 6 N·m

ENGINE ASSEMBLY

REMOVAL AND INSTALLATION

Pre-removal and Post-installation Operation

- Hood Removal and Installation (Refer to GROUP 42.)
- Under Cover and Skid Plate Removal and Installation
- Engine Oil Draining and Refilling (Refer to GROUP 12 - On-vehicle Service.)
- Battery and Battery Tray Removal and Installation
- Air Cleaner Removal and Installation (Refer to GROUP 15.)
- Radiator Removal and Installation (Refer to GROUP 14.)
- Accelerator Cable Adjustment (Refer to GROUP 17 - On-vehicle Service.) <Post-installation operation>
- Fuel Line Air-bleeding (Refer to GROUP 13B - On-vehicle Service.) <Post-installation operation>
- Drive Belt Tension Check and Adjustment <Vehicles with A/C> (Refer to P.11B-6.) <Post-installation operation>

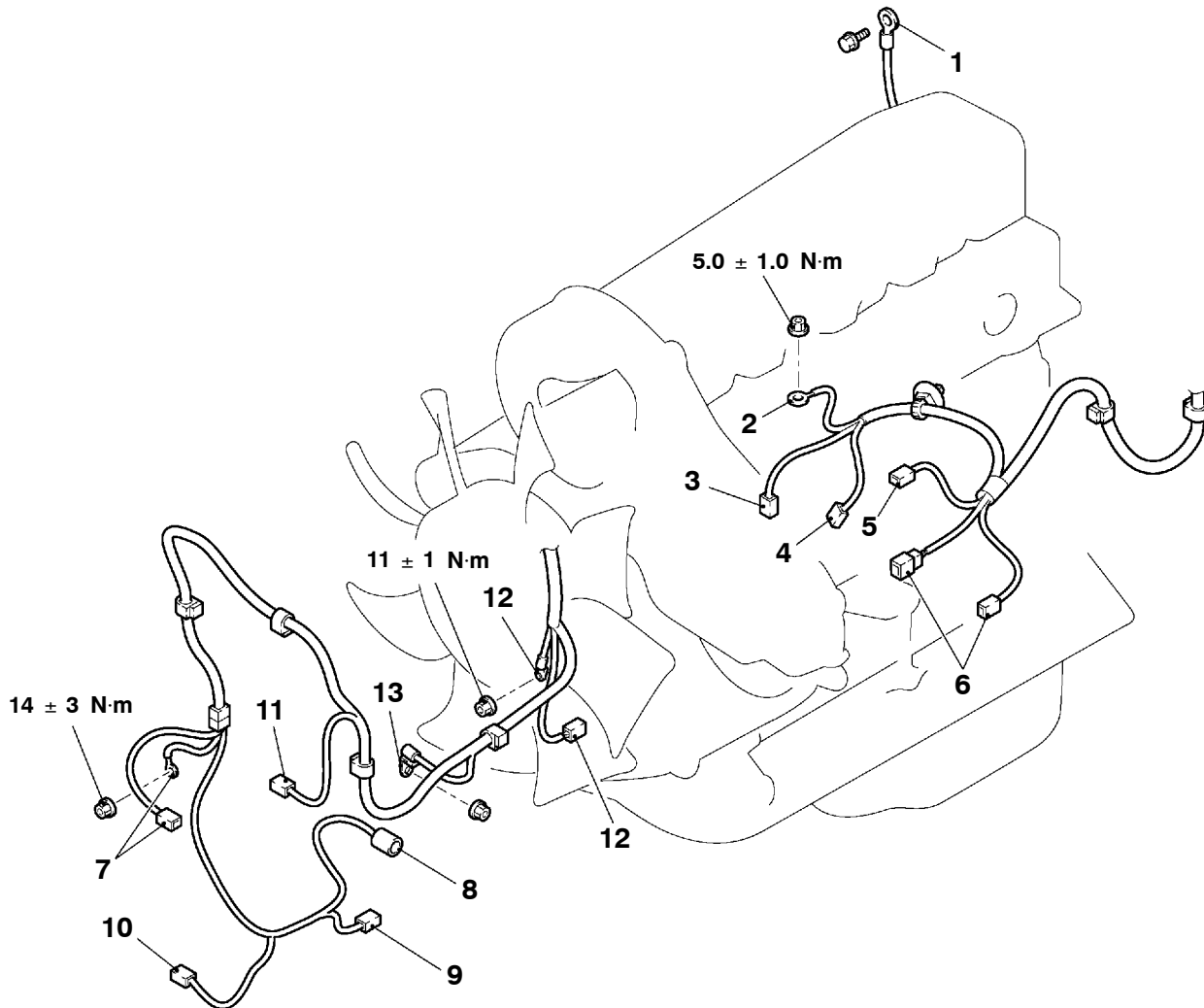

AY0279CA

Removal steps

1. Earth cable connection
2. Glow plug connector
3. Engine coolant temperature switch connector (for A/C compressor control)
4. Engine coolant temperature switch connector (for condenser fan control)
5. Fuel cut solenoid valve connector
6. Injection pump connector
7. Alternator connector
8. Oil pressure switch connector
9. Engine oil level sensor connector
10. Free-wheeling hub engage switch
11. A/C compressor connector <Vehicles with A/C>
12. Starter connector
 - A/C compressor assembly <Vehicles with A/C> (Refer to P.11B-19.)
13. Earth cable connection

Caution

*: indicates parts which should be temporarily tightened, and then fully tightened with the engine weight applied on the vehicle body.

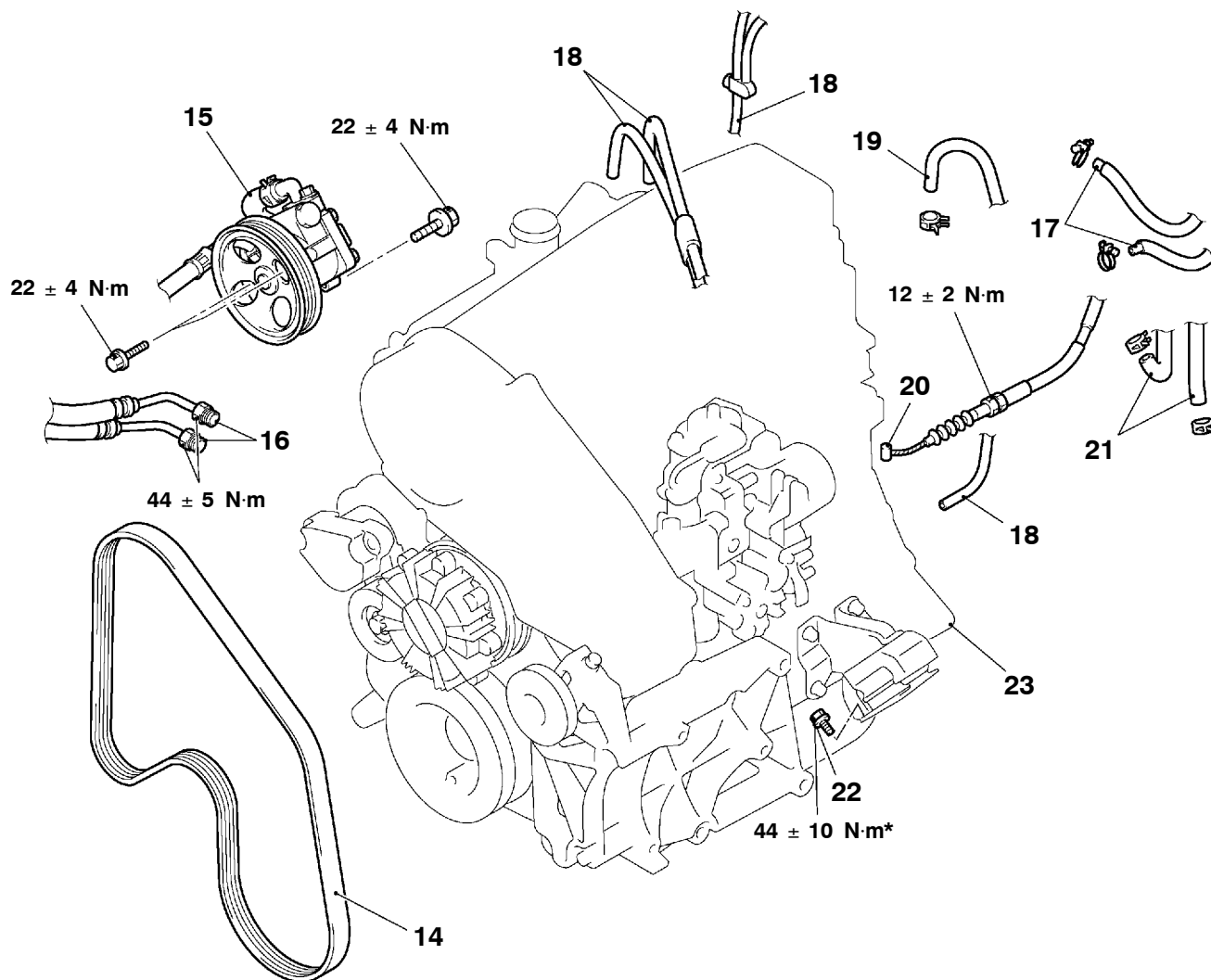

AY0280CA

◀A▶

◀B▶

- Cooling fan
(Refer to GROUP 14.)
- 14. Alternator and power steering oil pump drive belt
- 15. Power steering oil pump assembly
- 16. Engine oil cooler hoses connection
- 17. Fuel hoses connections
- 18. Vacuum hoses connection
- 19. Brake booster vacuum hose connection <Vehicles with ABS>

- 20. Accelerator cable connection
- 21. Heater hoses connection
<Vehicles with A/C>
 - Transmission assembly
(Refer to GROUP 22.)
- 22. Engine support front insulator attaching bolt
- 23. Engine assembly

◀C▶

▶A◀

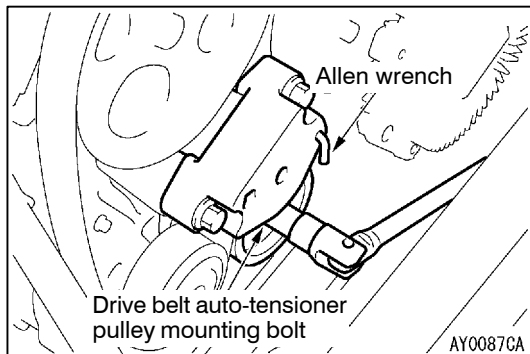

REMOVAL SERVICE POINTS

◀A▶ ALTERNATOR AND POWER STEERING PUMP DRIVE BELT REMOVAL

The following operations will be needed due to the introduction of the serpentine drive system with the drive belt auto tensioner.

1. Locate a ring spanner onto the drive belt auto-tensioner pulley mounting bolt, and move the tensioner clockwise until it touches the stopper.
2. Hold the tensioner by inserting an Allen wrench as shown, and remove the drive belt.

Caution

To reuse the drive belt, mark its running direction (clockwise direction) on the belt back side with a chalk.

◀B▶ POWER STEERING OIL PUMP ASSEMBLY REMOVAL

1. Remove the power steering oil pump assembly from the timing gear case with its hoses still attached.
2. Suspend the power steering oil pump with a cord out of the way.

◀C▶ ENGINE ASSEMBLY REMOVAL

1. Check that all cables, hoses, harness connectors, etc. are disconnected from the engine.
2. Lift the chain block slowly to remove the engine assembly upward from the engine compartment.

INSTALLATION SERVICE POINT

▶A▶ ENGINE ASSEMBLY INSTALLATION

Install the engine assembly. When doing so, check carefully that all pipes and hoses are connected, and that none are twisted, damaged, etc.

ENGINE <4D5>

CONTENTS

GENERAL	2	ON-VEHICLE SERVICE	4
Outline of Changes	2	Injection Timing Check and Adjustment	4
GENERAL INFORMATION	2	Idle Speed Check	4
SERVICE SPECIFICATIONS	2	OIL PAN AND OIL SCREEN	5
SEALANT	2	TIMING BELT AND TIMING BELT B	7
SPECIAL TOOLS	3	CYLINDER HEAD GASKET	13

GENERAL

OUTLINE OF CHANGES

Some service procedures have been revised as the following changes have been made to comply to the Emission Regulation Step III.

- Injection timing and idle speed check and adjustment have been changed as the electronic-controlled fuel injection pump has been introduced.
- The oil pan has a cover in order to reduce noise due to an enhanced engine output.
- A crank angle sensor and crankshaft sensing blade have been added due to the introduction of an electronic-controlled fuel injection pump. Due to this change, the timing belt front lower cover has been reshaped.
- The tightening torque of the cylinder head bolts and the cylinder head gasket have been changed.

GENERAL INFORMATION

Items		4D56	
Total displacement mL		2,477	
Bore x Stroke mm		91.1 x 95.0	
Compression ratio		21	
Combustion chamber		Vortex chamber type	
Camshaft arrangement		SOHC	
Number of valve	Intake	4	
	Exhaust	4	
Valve timing	Intake	Opening	BTDC 20°
	Exhaust	Closing	ABDC 49°
	Intake	Opening	BBDC 55°
	Exhaust	Closing	ATDC 22°
Fuel system		Electronically controlled type injection pump	
Rocker arm		Roller type	
Adjusting screw		Elephant foot type	

SERVICE SPECIFICATIONS

Items	Standard value
Idle speed r/min	750 ± 30
Timing belt tension mm	4 - 5
Timing belt B tension mm	4 - 5

SEALANT

Items	Specified sealant	Remarks
Oil pan	MITSUBISHI GENUINE PART MD970389 or equivalent	Semi-drying sealant

SPECIAL TOOLS

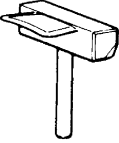
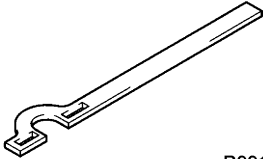
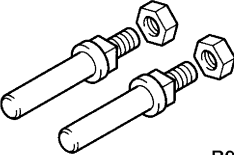
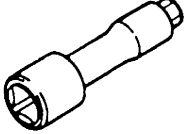
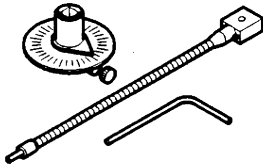
Tools	Number	Name	Use
	MD998727	Oil pan remover	Removal of oil pan
 B991800	MB991800	Crankshaft pulley holder	Holding the crankshaft pulley
 B991802	MB991802	Pin B	
	MD998051	Cylinder head bolt wrench	Removal and installation of the cylinder head bolt
	MB991614	Angle gauge	Tightening of the cylinder head bolts

ON-VEHICLE SERVICE

INJECTION TIMING CHECK AND ADJUSTMENT

The cold start device (wax type) has been discontinued as an electronically controlled injection pump has been used. The other inspection and adjustment procedures are the same as before.

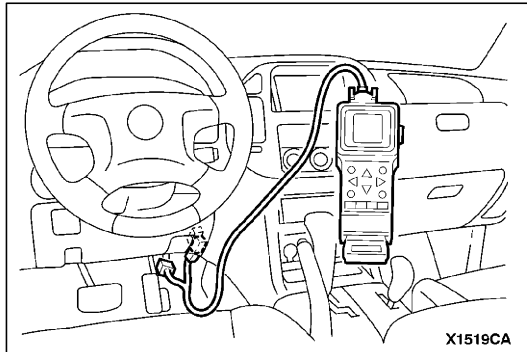

IDLE SPEED CHECK

1. Set the vehicle to the pre-inspection condition.
2. Turn the ignition switch to "LOCK" (OFF) position, and connect the diagnosis connector to the MUT-II.
If the MUT-II is not used, connect a tachometer to the injection nozzle or the pipe.
3. Start the engine, and let it run at idle.
4. Check the idle speed.

Standard value: 750 ± 30 r/min

5. If the idle speed is not within the standard value, refer to 13C - Troubleshooting to check the electronic controlled fuel injection system.

NOTE

The idle speed is controlled by the engine-ECU.

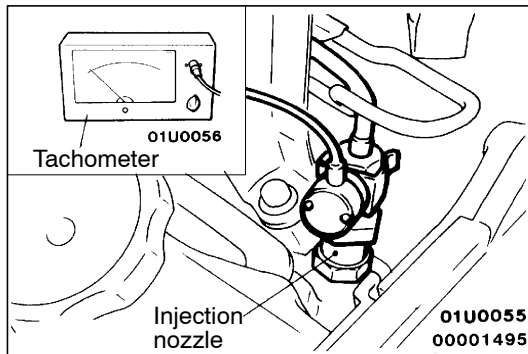

OIL PAN AND OIL SCREEN

REMOVAL AND INSTALLATION

Pre-removal and Post-installation Operation

- Skid Plate and Under Cover Removal and Installation.
- Engine Oil Draining and Supplying.
- Differential Gear Oil Draining and Supplying.
- Front Differential and No.2 Crossmember Assembly Removal and Installation.

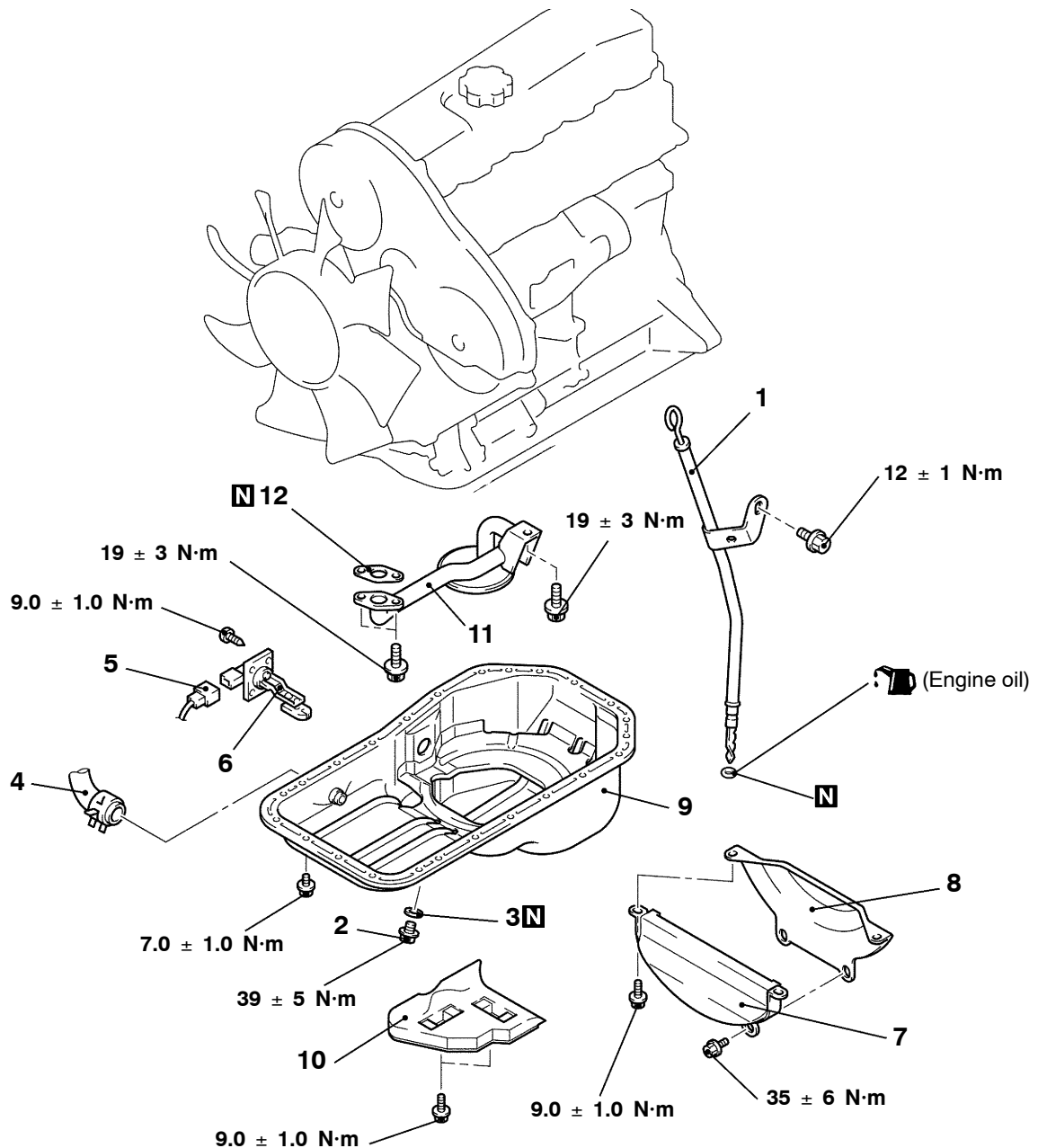

A10027CA

Removal steps

- | | |
|---|--|
| <p>►B◄</p> <ol style="list-style-type: none"> 1. Engine oil level gauge and guide assembly 2. Drain plug 3. Drain plug gasket 4. Alternator vacuum pump oil return hose connection 5. Oil level sensor connector | <p>◄A► ►A◄</p> <ol style="list-style-type: none"> 6. Oil level sensor 7. Space rubber 8. Bell housing cover 9. Oil pan 10. Oil pan cover 11. Oil screen 12. Oil screen gasket |
|---|--|

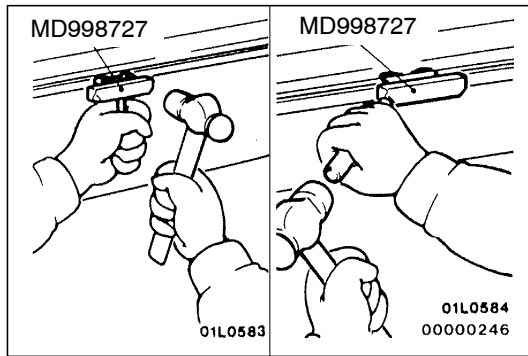

REMOVAL SERVICE POINT

◀A▶ OIL PAN REMOVAL

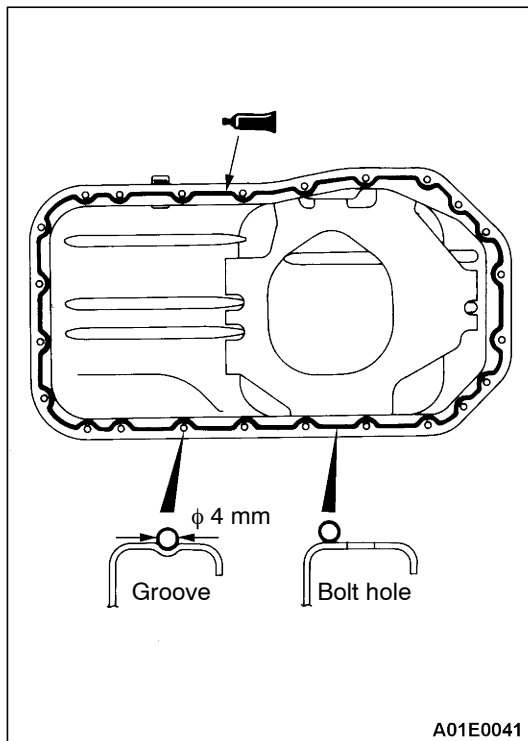

INSTALLATION SERVICE POINTS

▶A◀ OIL PAN INSTALLATION

1. Remove sealant from oil pan and cylinder block mating surfaces.
2. Degrease the sealant-coated surface and the engine mating surface.
3. Apply a continuous bead of the specified sealant to the oil pan mating surface as shown.

Specified sealant:

MITSUBISHI GENUINE PART No. MD970389 or equivalent

NOTE

The sealant should be applied in a continuous bead approximately 4 mm in diameter.

4. Assemble oil pan to cylinder block within 15 minutes after applying the sealant.

Caution

After installing the oil pan, wait at least 1 hour before starting the engine.

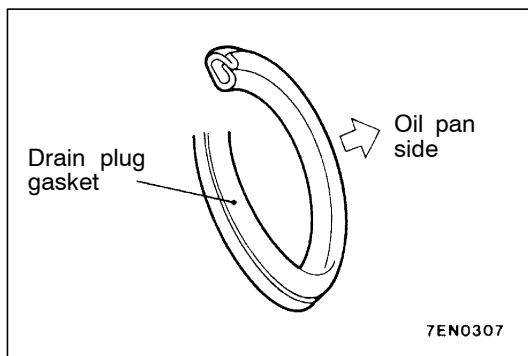

▶B◀ DRAIN PLUG GASKET INSTALLATION

Install a new gasket in the direction so that it faces as shown in the illustration.

INSPECTION

- Check oil pan for cracks.
- Check oil pan sealant-coated surface for damage and deformation.
- Check oil screen for cracked, clogged or damaged wire net and pipe.

TIMING BELT AND TIMING BELT B

REMOVAL AND INSTALLATION

Post-installation Operation

Drive Belt Tension Check and Adjustment.

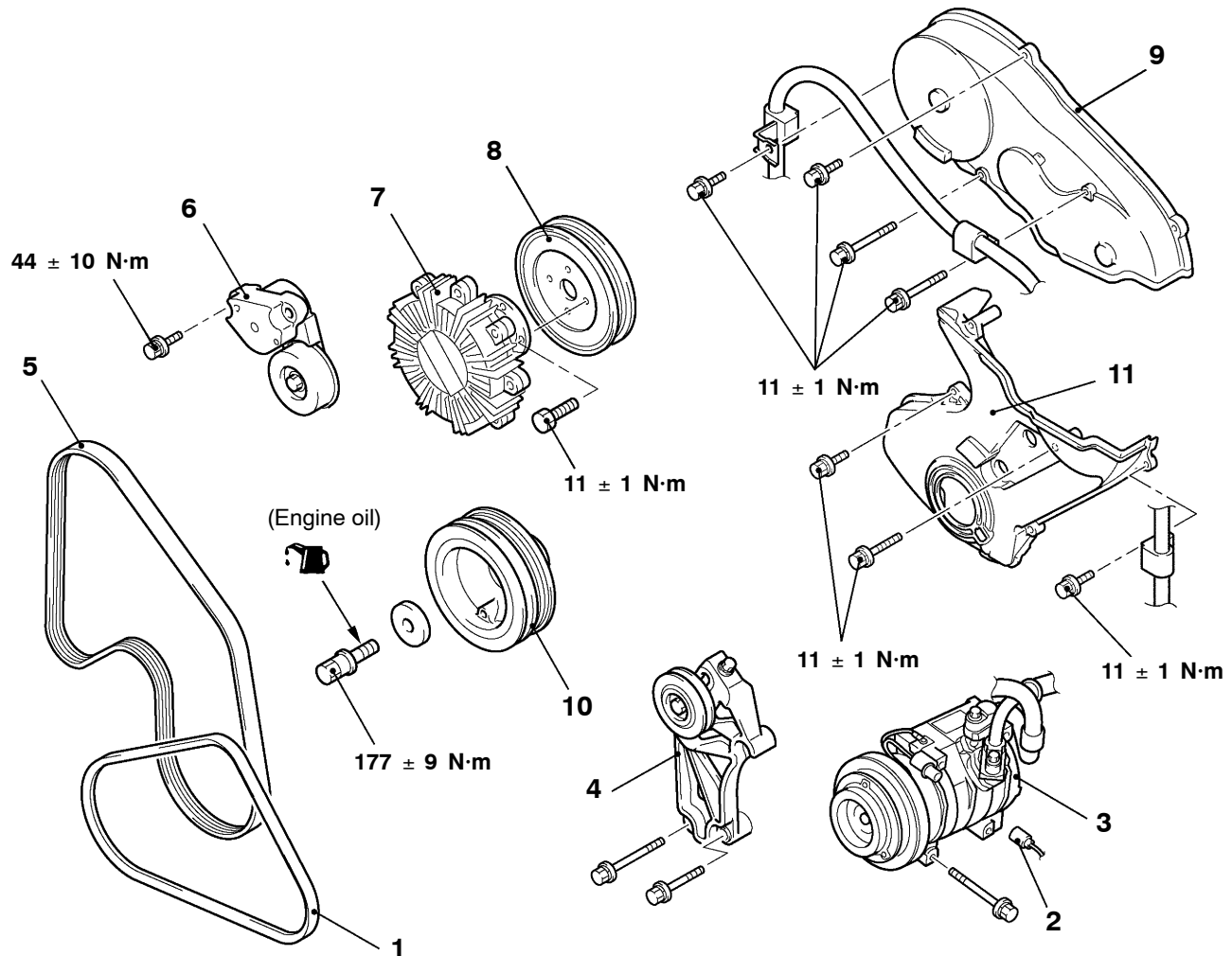

A10028CA

Removal steps

- ◀A▶ ● Radiator upper shroud
- 1. A/C compressor drive belt <Vehicles with A/C>
- 2. A/C compressor connector <Vehicles with A/C>
- 3. A/C compressor <Vehicles with A/C>
- 4. Tension pulley and tension pulley bracket assembly <Vehicles with A/C>
- Cooling fan
- ◀C▶ 5. Alternator and power steering oil pump drive belt
- 6. Auto-tensioner
- 7. Fan Clutch
- 8. Water pump pulley
- ◀D▶ ▶C▶ 9. Timing belt front upper cover
- ▶C▶ 10. Crankshaft pulley
- ▶C▶ 11. Timing belt front lower cover

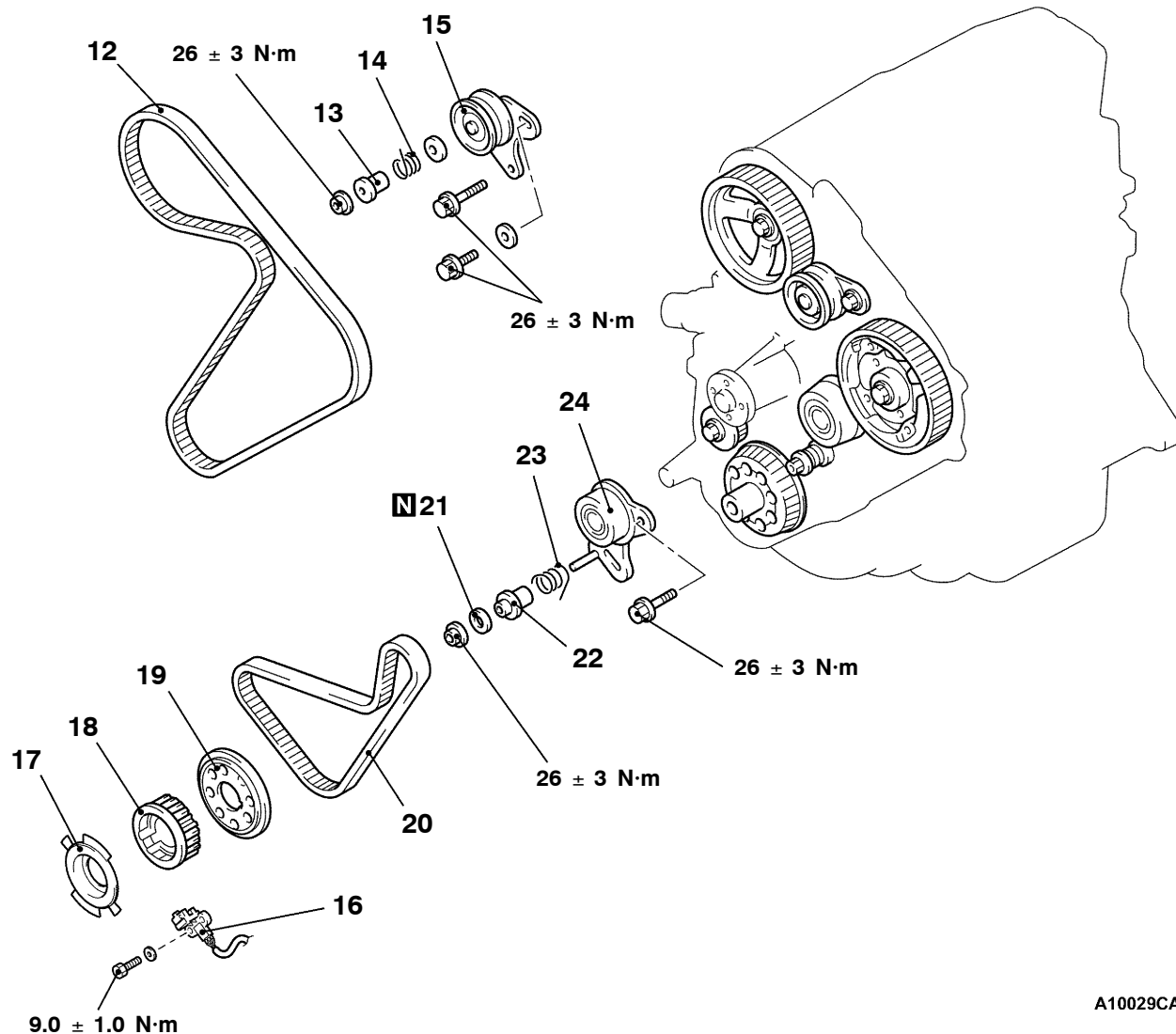

A10029CA

- ◀E▶ ▶B▶ 12. Timing belt
- 13. Tensioner spacer
- 14. Tensioner spring
- 15. Timing belt tensioner
- 16. Crank angle sensor
- 17. Crankshaft sensing blade
- 18. Crankshaft sprocket

- ◀F▶ ▶A▶ 19. Flange
- 20. Timing belt B
- 21. Gasket
- 22. Tensioner spacer B
- 23. Tensioner spring B
- 24. Timing belt tensioner B

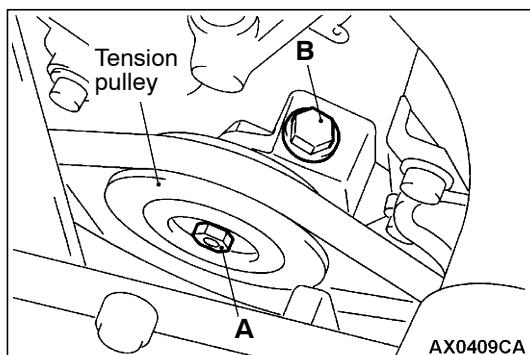

REMOVAL SERVICE POINTS

◀A▶ A/C COMPRESSOR DRIVE BELT REMOVAL

1. Loosen the tension pulley securing bolt A.
2. Loosen the adjusting bolt B to remove the belt.

Caution

To reuse the drive belt, mark its running direction (clockwise direction) on the belt back side with a chalk.

◀B▶ A/C COMPRESSOR REMOVAL

1. Remove the A/C compressor from the bracket with its refrigerant hoses still attached.
2. Suspend the A/C compressor with a cord out of the way.

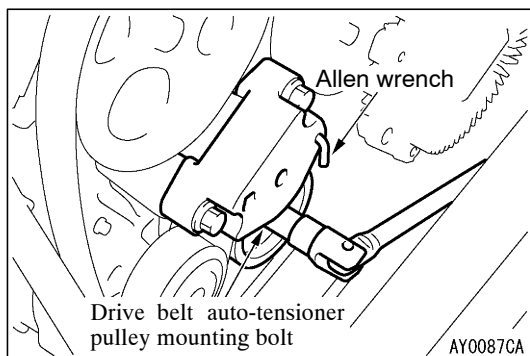
**◀C▶ ALTERNATOR AND POWER STEERING PUMP DRIVE BELT REMOVAL**

The following operations will be needed due to the introduction of the serpentine drive system with the drive belt auto-tensioner.

1. Locate a ring spanner onto the drive belt auto-tensioner pulley mounting bolt, and move the tensioner clockwise until it touches the stopper.
2. Hold the tensioner by inserting an Allen wrench as shown, and remove the drive belt.

Caution

To reuse the drive belt, mark its running direction (clockwise direction) on the belt back side with a chalk.

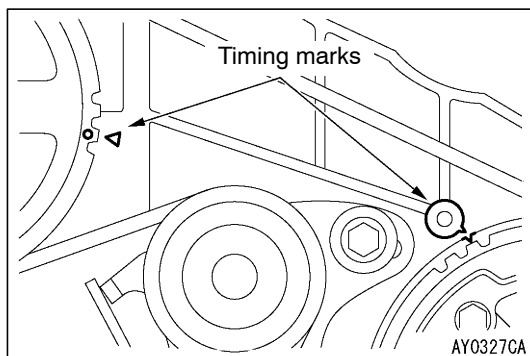
**◀D▶ CRANKSHAFT PULLEY REMOVAL**

1. Turn the crankshaft clockwise, align the timing marks to set No.1 cylinder to TDC of its compression stroke.

Caution

Never turn the crankshaft anticlockwise.

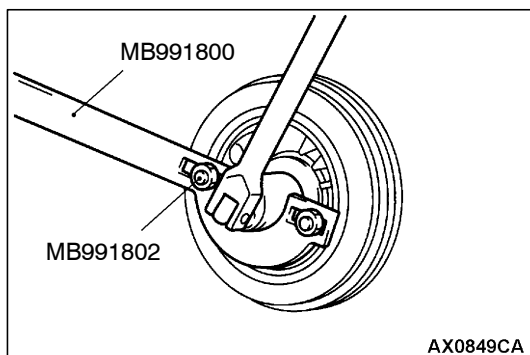

2. Use the special tool to keep crankshaft from turning and remove the bolts.

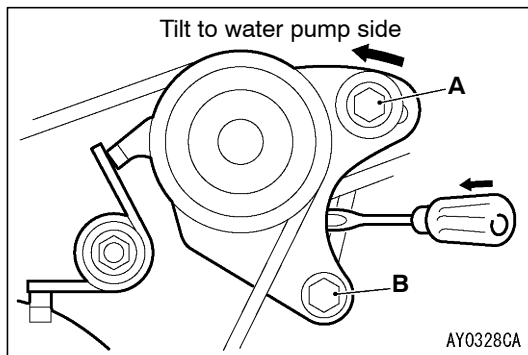

◀E▶ TIMING BELT REMOVAL

1. When reinstalling timing belt, mark an arrow at the belt to show rotation direction.
2. Loosen the tensioner mounting bolt A and B.
3. Push timing belt tensioner to water pump side and tighten the tensioner mounting bolt A and B. Secure so that tensioner will not move back.

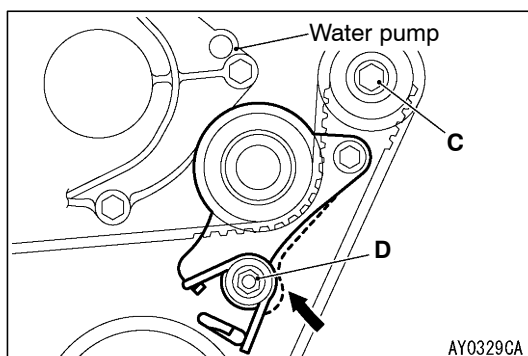

◀F▶ TIMING BELT B REMOVAL

1. When reinstalling timing belt B, mark an arrow at the belt to show rotation direction.
2. Loosen the tensioner mounting bolt C and nut D.
3. Push timing belt tensioner to water pump side and tighten the tensioner mounting bolt C and nut D. Secure so that tensioner will not move back.

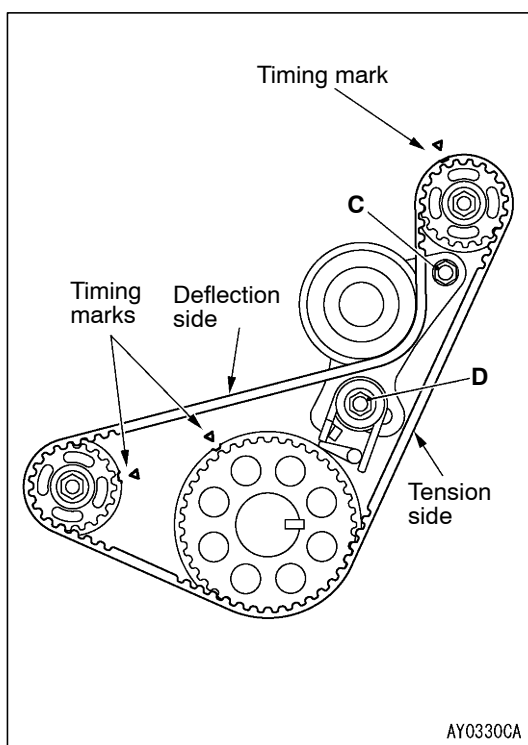

INSTALLATION SERVICE POINTS

▶A◀ TIMING BELT B INSTALLATION

1. Align the timing marks of the 3 sprockets.
2. When reusing timing belt B, make sure the arrow mark is pointing in the same direction as when the belt was removed.
3. Install timing belt B and make sure there is no deflection on the tension side.
4. Press the deflection side of timing belt B with the hand and fully stretch the tensioner side.
5. Make sure that the timing marks are aligned.
6. Loosen the tensioner mounting bolt and nut so that only the pressure of the spring is applied to timing belt B.
7. Tighten the tensioner mounting bolt C and nut D, tightening the nut first. If the bolt is tightened first, the tensioner will move and tension the belt.

Tightening torque: $26 \pm 3 \text{ N}\cdot\text{m}$

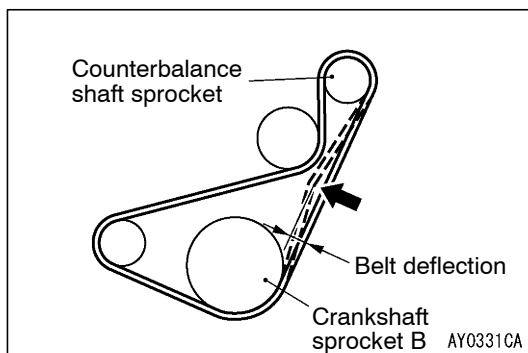

8. Press in the direction of the arrow in the figure with the index finger to check the amount of deflection.

Standard value: 4 - 5 mm

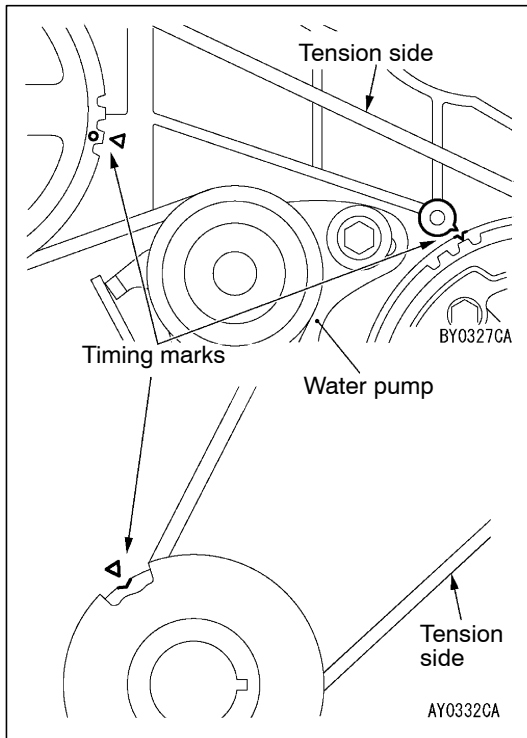

►B◀ TIMING BELT INSTALLATION

1. Align the timing marks of the 3 sprockets.
2. When reusing timing belt, make sure the arrow mark is pointing in the same direction as when the belt was removed.
3. Install the timing belt to the crankshaft sprocket, to injection pump sprocket, to tensioner and to camshaft sprocket in that order. Being careful not to allow deflection on the tension side of the timing belt.

Caution

- (1) Engage the belt on the various sprockets while maintaining tension on the belt of tension side.
- (2) Align the injection pump sprocket with the timing mark, hold the sprocket so that it does not turn and engage the belt.
4. Loosen the tensioner mounting bolts and apply tension with the spring.

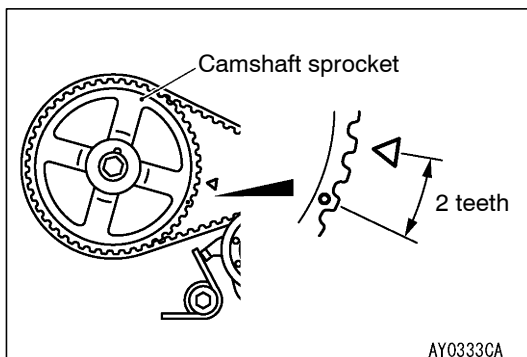

5. Turn the crankshaft clockwise and stop at the second lobe of the camshaft sprocket.

Caution

- (1) When turning the crankshaft in item (5), strictly observe the specified amount of rotation (2 teeth on the camshaft sprocket) in order to apply a constant force to the tension side of the belt.
- (2) Do not turn the crankshaft counterclockwise.
- (3) Do not touch the belt during adjustment.
6. Make sure that the part indicated by arrow A does not float upward.
7. Tighten the tensioner mounting bolts, starting with the bolt in the elongated hole. If the lower bolt is tightened first, belt tension will become too tight.
8. Turn the crankshaft anticlockwise and align the timing mark. Next, make sure that the timing marks of all sprockets are aligned.

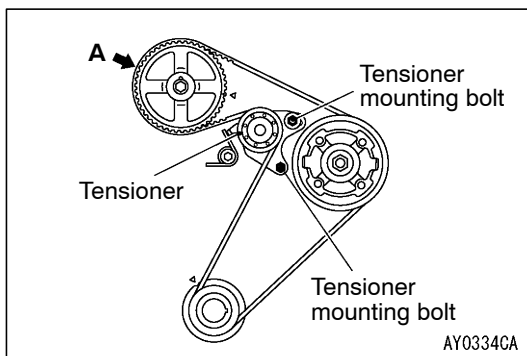

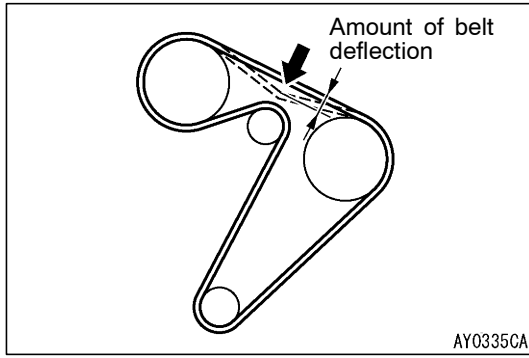

- Press on the center of the bolt with an index finger to check the amount of deflection.

Standard value: 4 - 5 mm

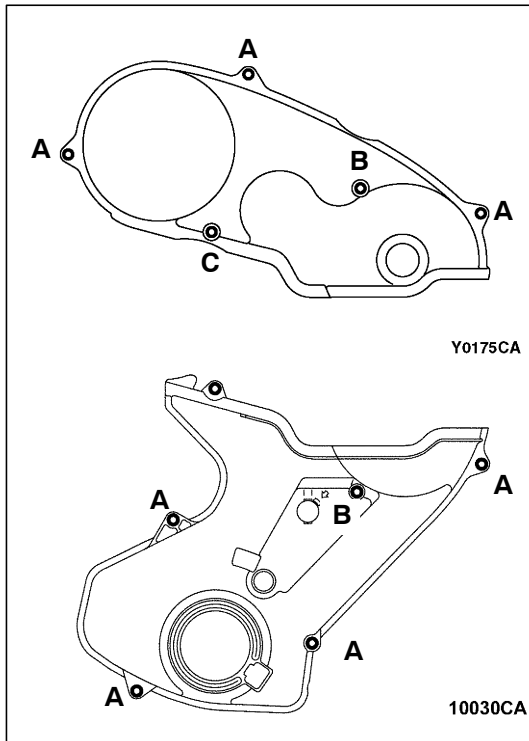

▶C◀ TIMING BELT FRONT LOWER COVER/TIMING BELT FRONT UPPER COVER INSTALLATION

Install the bolts to the timing belt cover at the shown positions.

Name	Symbols	Size mm (d × l)
Flange bolt	A	6 × 22
	B	6 × 50
	C	6 × 60

d=Nominal diameter
l=Nominal length

CYLINDER HEAD GASKET

REMOVAL AND INSTALLATION

Pre-removal and Post-installation Operation

- Cooling Fan and Fan Clutch Assembly Removal and Installation.
- Intake Manifold Removal and Installation (Refer to GROUP15 - Intake Manifold and Exhaust Manifold, Turbocharger <4D5>.)
- Engine Oil Check and Refill.
- Fuel Line Air-bleeding.
- Timing Belt Removal and Installation (Refer to P.11B-6.)

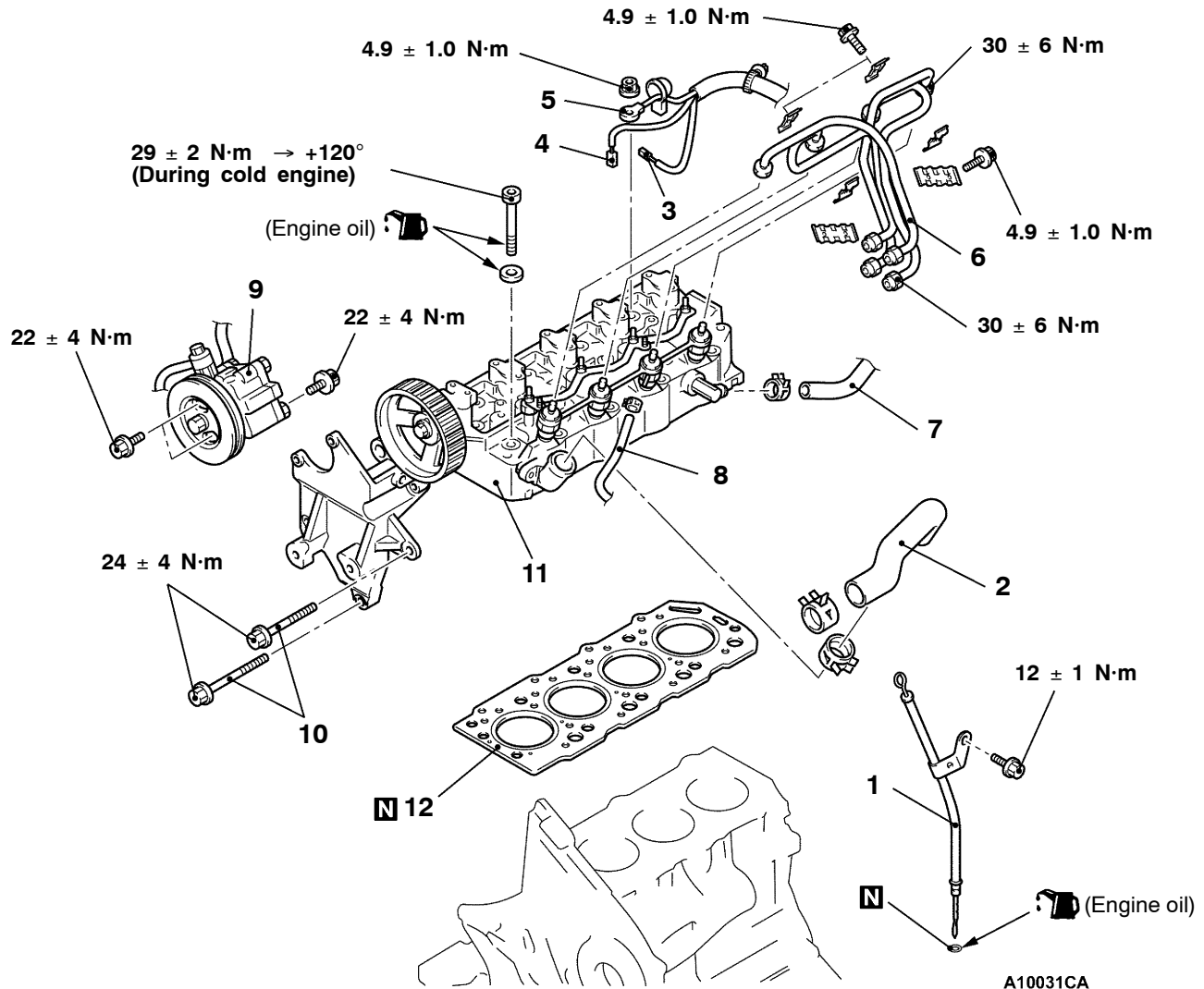

Removal steps

- | | |
|---|--|
| <p>◀A▶ ▶D▶</p> <ol style="list-style-type: none"> 1. Oil level gauge guide and oil level gauge assembly 2. Radiator upper hose <ul style="list-style-type: none"> ● Rocker cover 3. Engine coolant temperature switch connector (for A/C compressor control) 4. Engine coolant temperature switch connector (for condenser fan control) 5. Glow plug connector | <p>◀B▶ ▶C▶</p> <ol style="list-style-type: none"> 6. Fuel injection pipe 7. Heater hose connection 8. Fuel hose connection <ul style="list-style-type: none"> ● Water pipe assembly C (Refer to GROUP 14.) 9. Power steering oil pump assembly 10. Power steering oil pump bracket bolt 11. Cylinder head assembly 12. Cylinder head gasket |
|---|--|

REMOVAL SERVICE POINTS**◀A▶ RADIATOR UPPER HOSE DISCONNECTION**

After making mating marks on the radiator upper hose and the hose clamp, disconnect the radiator upper hose.

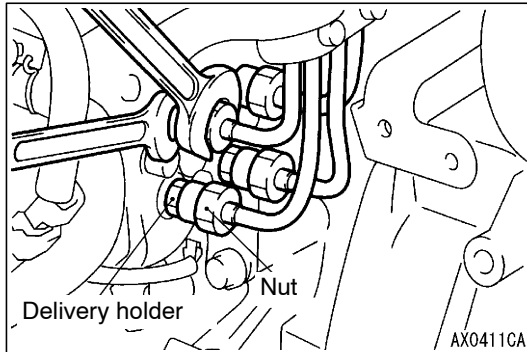
**◀B▶ FUEL INJECTION PIPE REMOVAL**

When loosening nuts at both ends of injection pipe, hold the delivery holder (for pump side) and the injection nozzle assembly (for nozzle side) with wrench and loosen nut.

Caution

After disconnecting the injection pipe, plug the opening so that no foreign particles get inside the pump or into the injection nozzle.

◀C▶ POWER STEERING OIL PUMP REMOVAL

Remove the power steering oil pump from the bracket with the hose attached.

NOTE

Place the removed power steering oil pump in a place where it will not be a hindrance when removing and installing the engine assembly, and tie it with a cord.

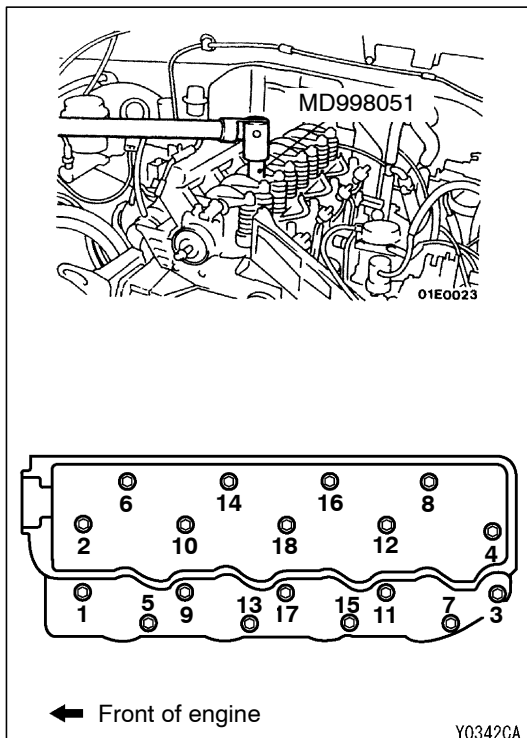
**◀D▶ CYLINDER HEAD ASSEMBLY REMOVAL**

Use the special tool to loosen the cylinder head bolts in the shown sequence progressively, and then remove the cylinder head bolts.

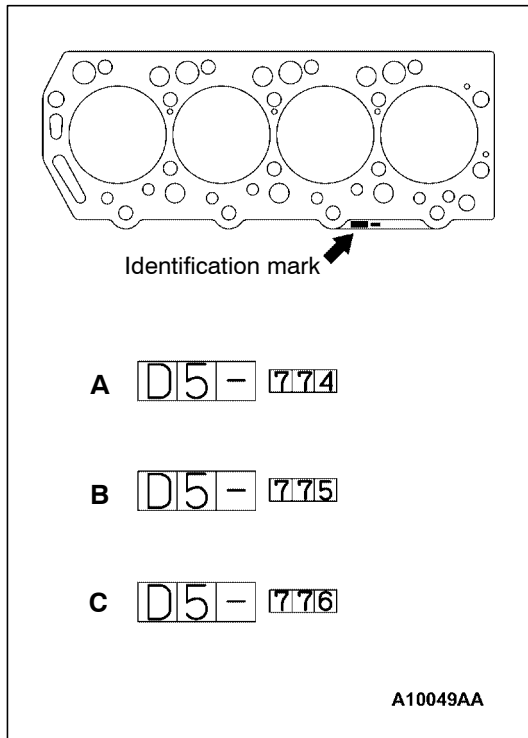

INSTALLATION SERVICE POINTS

►A◄ CYLINDER HEAD GASKET INSTALLATION

When replacing the cylinder head gasket only, confirm the gasket identification mark, and then select a replacement part according to the table below:

Spec	Identification mark (size)	Parts number
A	D5-774 (fitted thickness 1.45 ± 0.04)	MD377774
B	D5-775 (fitted thickness 1.50 ± 0.04)	MD377775
C	D5-776 (fitted thickness 1.55 ± 0.04)	MD377776

Caution

The thickness of the original cylinder head gasket is selected according to the protrusion amount of the piston. Therefore, if the piston or the connecting rod is replaced, the protrusion amount may be changed. Always select a correct gasket by measuring the protrusion amount. (For details, refer to the Engine Workshop Manual.)

►B◄ CYLINDER HEAD INSTALLATION

1. Select a cylinder head gasket of correct specification.
2. Clean the cylinder head assembly and the cylinder block mating surfaces with a scraper or a wire brush.

Caution

Do not allow foreign material to enter the engine coolant or oil passages and the cylinder.

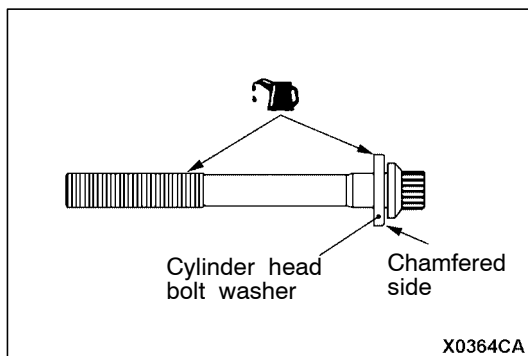

3. Install the cylinder head bolt washer to the cylinder head bolt so that the washer chamfered side faces as shown.
4. Apply a small amount of engine oil to the cylinder head bolt thread and the washer.

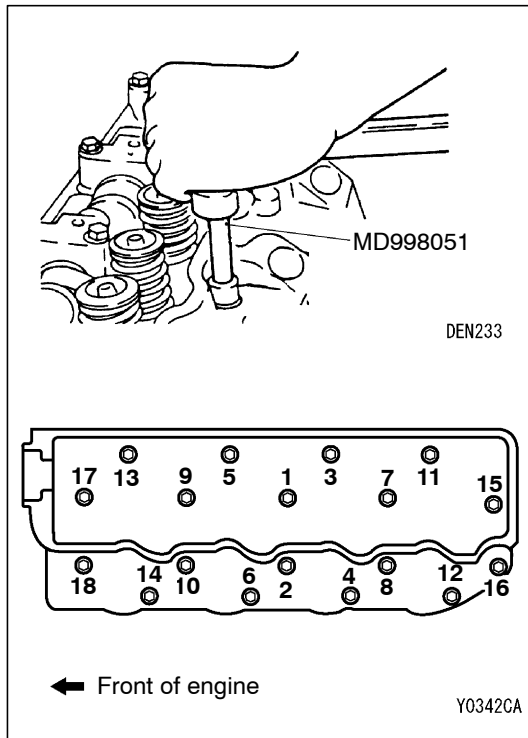

5. Tighten the cylinder head bolts according to the following procedure (angle-tightening procedure.)

- (1) Use the special tool to tighten the cylinder head bolts in the order of the illustrated numbers to 29 ± 2 N·m.

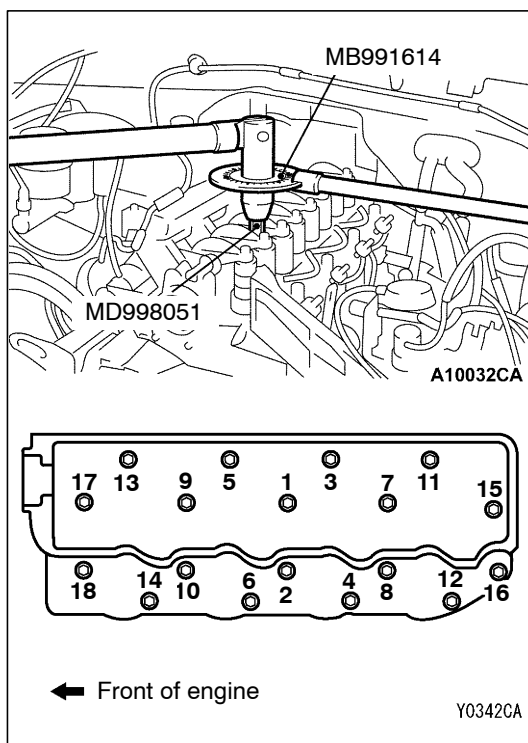

- (2) Place the special tool in a wrench to tighten the cylinder head bolt in the order of the illustrated numbers to 120° .

►◄ RADIATOR UPPER HOSE CONNECTION

To reuse the radiator upper hose, align the mating marks that were made during removal, and then install the hose clamp.

►◄ FUEL INJECTION PIPE INSTALLATION

When tightening the nuts at both ends of the fuel injection pipe, hold the delivery holder (for pump side) and the injection nozzle assembly (for nozzle side) with a wrench, and tighten the nuts to the specified torque.

Tightening torque: 30 ± 6 N·m

**Thank you very much
for your reading.**

Please Click Here

**Then Get More
Information.**