

SUZUKI LJ10

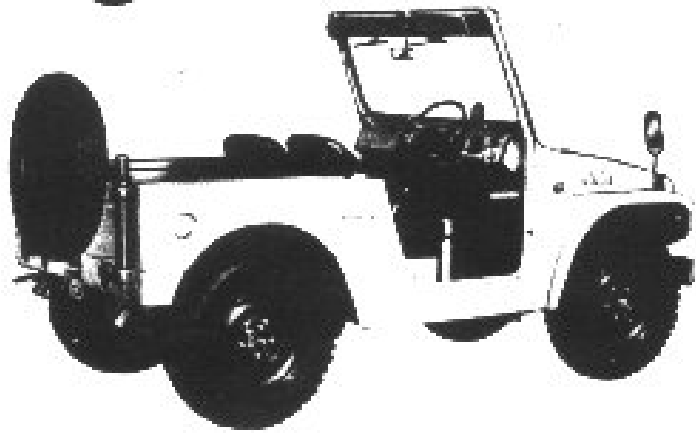

1. SUZUKI ENGINE LUBRICATION SYSTEM "C.C.I." (Posi-Force Lubrication)

The Suzuki LJ10 has a two-stroke engine with Suzuki's unique forced oiling system, "C.C.I." and newly-adopted "Reed Valve Intake System."

The Suzuki "C.C.I." eliminates the trouble of gasoline-oil mixing. Merely fill the gasoline and oil tanks separately, as in the case of a four-stroke vehicle.

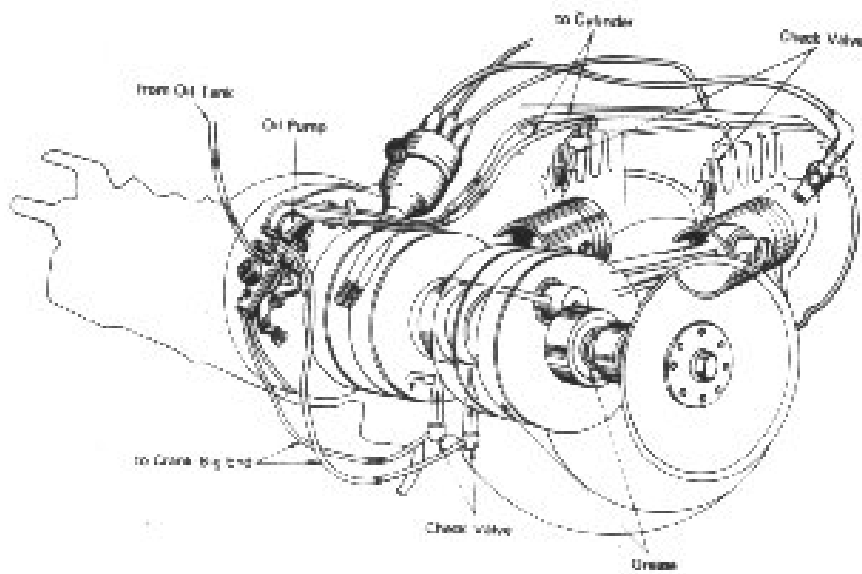

The SUZUKI "C.C.I." system is capable of feeding fresh oil directly to the crank shaft and cylinder. The amount of oil thus fed to necessary parts is controlled in accordance with both engine rev and throttle opening.

Merits of the "C.C.I."

- (1) Gives outstanding engine durability.
- (2) Allows continuous high-speed driving.
- (3) Eliminates oil waste.
- (4) Emits less exhaust fumes.
- (5) Eliminates engine stains.

2. CAR IDENTIFICATION NO. AND IGNITION SWITCH KEY

A. Car Identification Number

Your car identification number is imprinted on the right front chassis.

Suzuki LJ10 of this number is only your vehicle in the world.

When you contact your Suzuki dealer about your car, please use this number for identification.

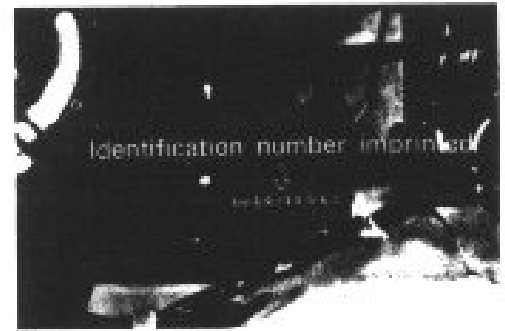

B. Ignition Switch Key and Glove Box Lock Key

Ignition switch key can be used as the glove box lock key, too.

Two pieces of key is prepared but one piece of key must be reserved for spare.

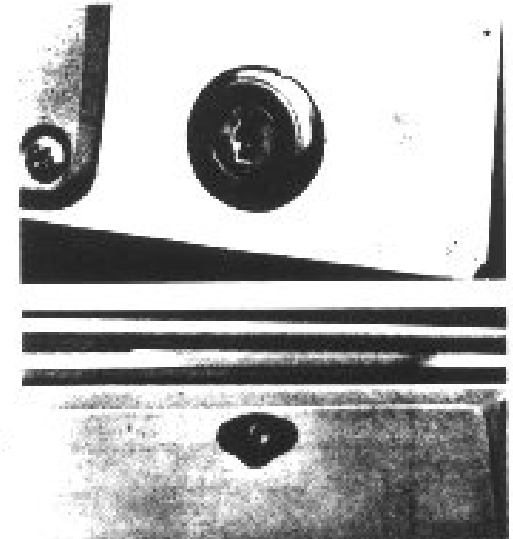
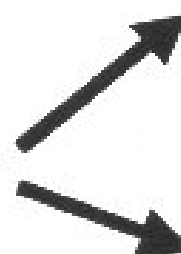
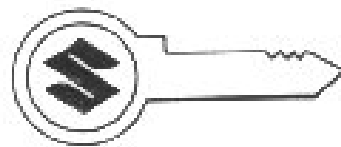

3. FOR BETTER MAINTENANCE

A. Breaking In

A correct breaking in procedure is necessary for maximum engine durability and performance. Please observe the following suggestions during the important first 1,800 miles (3,000 kilometers) of driving.

- (1) Warm up the engine at low rpm for two to three minutes before driving.
- (2) Avoid racing the engine.
- (3) Do not make sudden starts or stops.
- (4) Have your car checked regularly at your Suzuki dealer for initial adjustment.
- (5) Avoid continuous high-speed driving.



Mileage \ Gear	1st Gear		2nd Gear		3rd Gear		Top Gear	
	kph	mph	kph	mph	kph	mph	kph	mph
Up to 600 mi (1,000 km)	15	10	25	16	40	25	55	35
From 600 mi (1,000 km) To 1,800 mi (3,000 km)	Speed limits may be gradually increased up to max. rated speeds.							

B. Genuine Parts

When replacing parts, always use genuine Suzuki Parts, which are precision made under severe quality control. If imitation parts (not genuine parts) are used, good performance cannot be expected from your vehicle and in the worst case, they can cause a break down.

C. Engine Oil

Be sure to check the oil level warning lamp before starting engine. If the oil level warning lamp is glowed brightly, replenish the oil tank with Suzuki C.C.I. oil, non-diluent oil (non-self mixing type), Two Stroke Oil or Outboard Motor Oil with around SAE 30 wt.

D. Gasoline

Please use super gasoline with Octane Rating 90–100 in Research Method for this model.

E. Gear Oil

Please use SAE No. 90 gear oil for the LJ10 transmission, transfer gear and differential gear. To keep in good condition, renew gear oil after the first 500 miles (800 km) and every 2,000 miles (3,200 km) afterward to increase the engine durability.

F. Brake Fluid

Use high-quality brake fluid for your safety.

G. Notice For Using Four Wheel Drive

- (1) Don't use four wheel drive on the pavement.
- (2) Use four wheel drive when running on rough road or climbing slope.
- (3) Avoid high speed running when use four wheel drive under 40 km/h (25 mi/h)

4. BODY AND CHASSIS PARTS

A. Body Parts (Front)

- ① Front Turn Signal/Parking Lamp
- ② Bonnet
- ③ Headlamp
- ④ Front Hood Stopper
- ⑤ Side Turn Signal Lamp
- ⑥ Spare Tire
- ⑦ Front Gate Bar

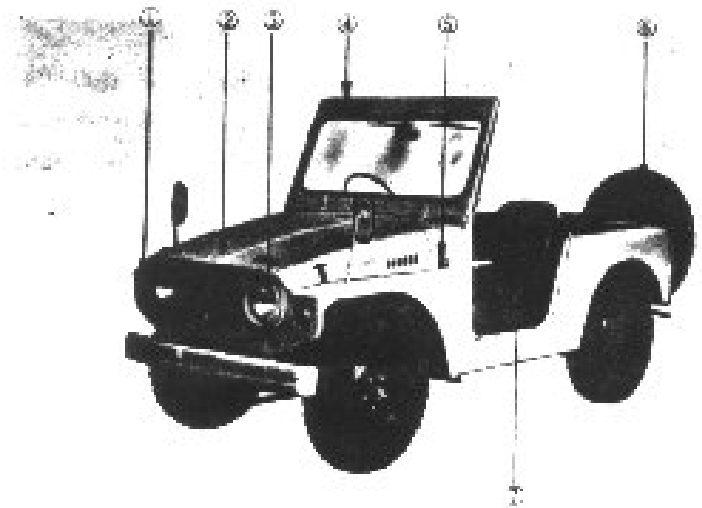

B. Body Parts (Rear)

- ① Rear Turn Signal/Tail/Parking Lamp
- ② Tow Hook
- ③ Brake Lamp
- ④ Fuel Tank Cap
- ⑤ Wiper Motor
- ⑥ Room Mirror
- ⑦ Sun Visor
- ⑧ Rear View Mirror
- ⑨ Back-up Lamp

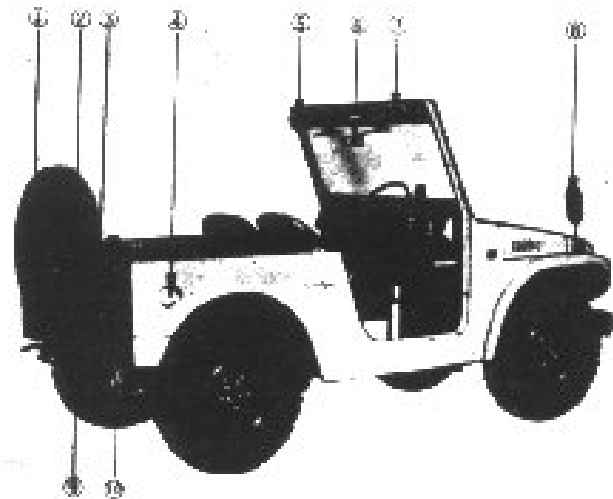

C. Perspective View

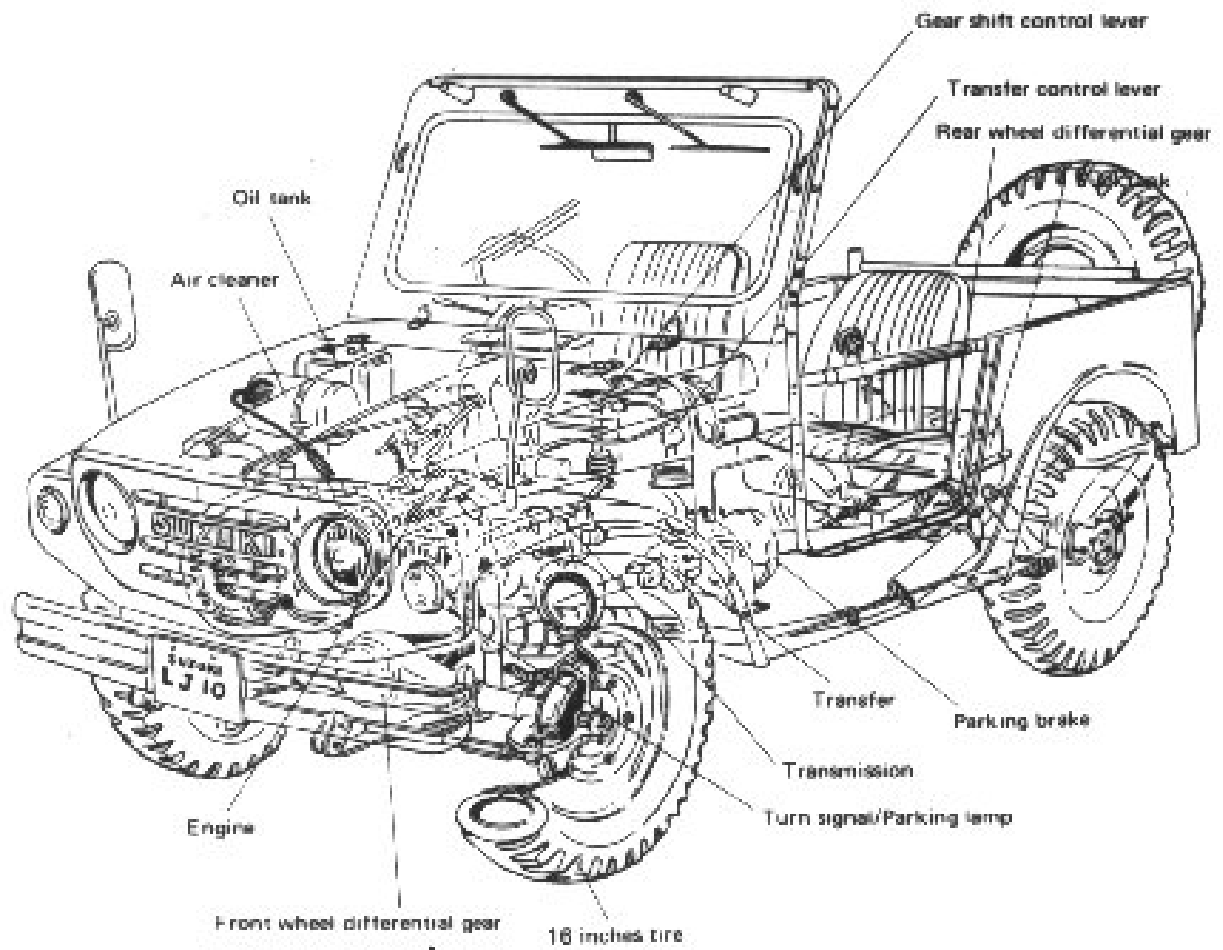

D. INSTRUMENTS

- ① Glove Pocket Knob
- ② Choke Knob
- ③ Ash Tray
- ④ Washer Pump
- ⑤ Wiper Switch
- ⑥ Speedometer
- ⑦ Steering Wheel
- ⑧ Fuel Meter
- ⑨ Lighting Switch
- ⑩ Ignition Switch
- ⑪ Parking Brake Lever
- ⑫ Transfer Gear Control Lever
- ⑬ Gear Shift Control Lever
- ⑭ Room Lamp
- ⑮ Clutch Pedal
- ⑯ Brake Pedal
- ⑰ Accelerator Pedal
- ⑱ Horn Button
- ⑲ Front Gate Bar

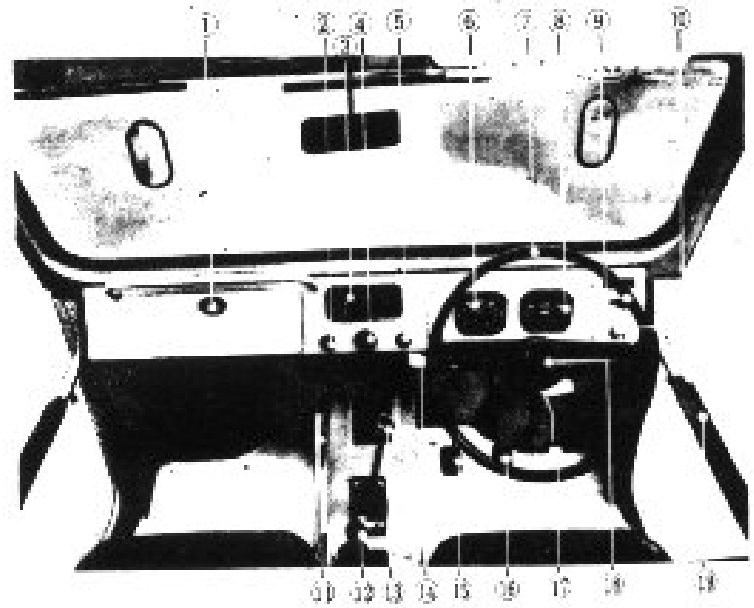

5. OPERATION

A. Instruments and Switches

◆ Oil Level Indicator Lamp

When the engine oil level is adequate, the center of the oil level pilot lamp glows faintly with the ignition switch on. If the volume of engine oil in the tank drops below the minimum level (0.5 ltr/1.0 US pt, 0.9 Imp pt), the pilot lamp glows brightly, indicating that you must add engine oil immediately. If the pilot lamp does not glow at all, there must be wiring or bulb problems. (Inspect the possible causes of trouble immediately.)

◆ High Beam Indicator Lamp

This lamp glows blue when the head lamps are on high beam and it goes out when on low beam. Use low beam when meeting other vehicles.

◆ Charge Warning Indicator Lamp

When the ignition is "on", the charge warning lamp glows red. When the engine begins running and the generator starts charging, the pilot lamp should cease glowing. If the lamp continues to glow, even while the engine is running, there is probably some problem with the electrical system. Have it inspected immediately.

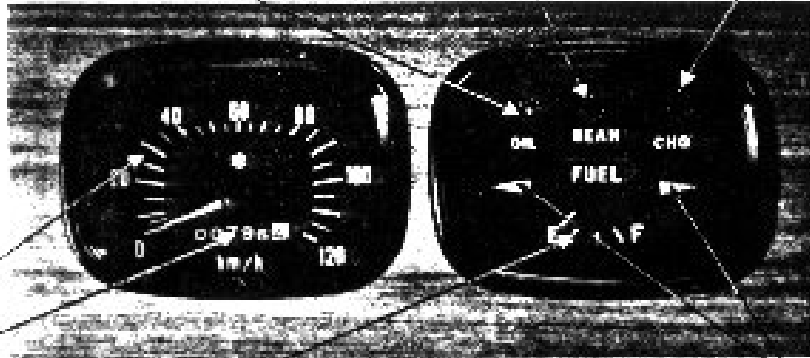

◆ Speedometer

◆ Odometer

◆ Fuel Gauge

The fuel gauge is activated when the ignition is turned on. When the needle lies at the F position, the fuel tank is full, and when the needle lies at the E position, the tank is empty. Approx. 3 ltr (0.80/0.65 gal, US/Imp) of fuel remains in the tank at this time.

◆ Turn Signal Indicator Lamp

Move the turn signal switch lever up for a left signal or down for a right signal. The pilot lamp on the instrument panel flashes when a signal is being given.

◆ Ignition Switch

When the key is turned to position ① in the illustration, the battery ignition is on. To operate the engine starter, turn the key further to the right, to position ② in the illustration. When the engine starts, release the key which will return automatically to the ① position, disengaging the starter motor.

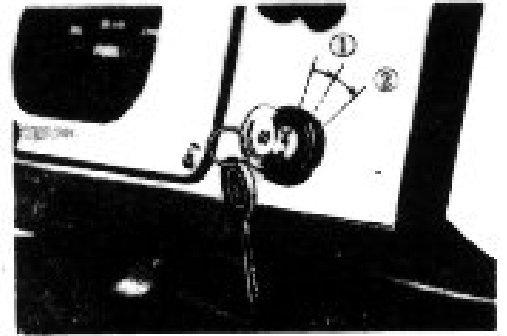

◆ Lighting Switch

The lighting switch pulls out in two stages,

Lamp	First Stage	Second Stage
Tail Lamp	○	○
License Lamp	○	○
Combination Meter Lamp	○	○
Head Lamp		○

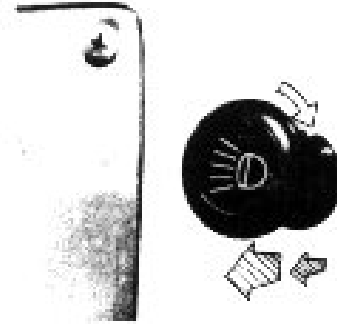

Parking lamp lights by twisting the lighting switch right instead of pulling the lighting switch. (But right handle vehicle only).

◆ Choke Knob

This knob facilitates the starting of the cold engine, in cold weather. When you pull this knob, the airgasoline mixture to the engine becomes richer. To start, pull out this knob and start the engine, without pressing down the accelerator. After the engine has warmed up, push the knob back to its original "off" position.



◆ Windshield Washer Pump

To wash the windshield depress the rubber bulb, at the same time turning on the windshield wiper switch. Put soap suds into the washer tank. When sourcing additive or anti-freezer (not for coolant), follow their instructions.



◆ Wiper Switch

The windshield wiper begins working when you pull out the wiper switch, and stops working when you push in the switch.

This switch works only when the ignition is "on".

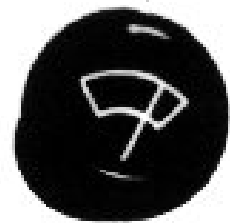

◆ Direction Indicator & Head Lamp Beam Switch Lever

Direction indicators are given by moving this lever vertically up for a left turn and down for a right turn. This lever automatically returns to the "off" position when the steering wheel is back to straight ahead drive position. If the lever is pulled up, the beams change.

Get proper beams as required. The high beam indicator lamp turns on when the head lamp beams are on high beam.



◆ Transfer Control Lever

When operating the transfer control lever, stop the vehicle, disengage the clutch and shift the gear shift control lever in Neutral.

1. Shift into "Normal Running" and the vehicle becomes to be driven only by rear wheel. In this case, the vehicle can be used normal flat roads.
2. It is recommendable to use four wheel drive mechanism at rough road and slope and, according to the road condition to select either gear position of high speed or low speed.
3. When the lever is in "Neutral", the power is not transferred.

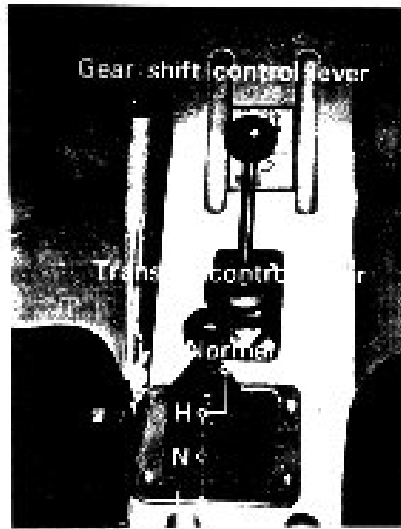

◆ Gear Shift Control Lever

Before operating the gear shifting lever, make sure that the transfer control lever is in any gear position of "Normal Running", "High-speed" or "Low-speed".

Engage the transmission (4 speeds forward, 1 reverse) by this lever as shown picture. Shifting into reverse gear, slide the lever to right and downward, pushing it down.

Steering and Body Parts

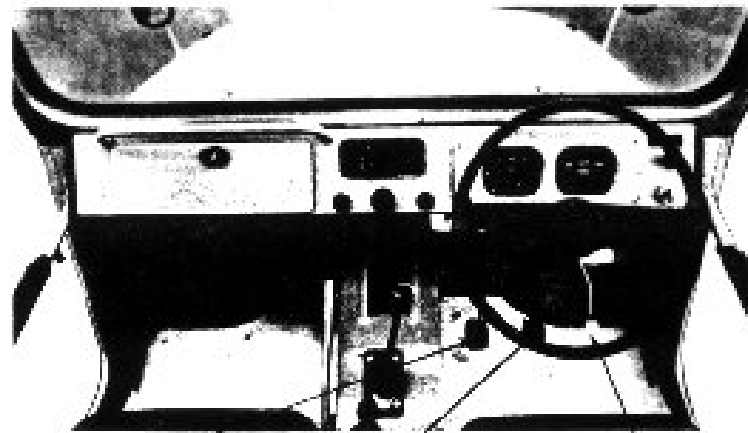

◆ Clutch Pedal

Depressing this pedal disconnects the engine power to the transmission and releasing it connects the engine power. When shifting gears, put it down positively and quickly. Release it slowly and smoothly. Do not rest your foot on this pedal when running.

◆ Brake Pedal

This pedal applies hydraulic braking on all wheels. When stopping the vehicle, depress it slowly and smoothly without depressing the clutch pedal until just before the vehicle is brought to a halt. When the pedal is depressed, the brake lamps turn on.

◆ Accelerator Pedal

The speed of the engine is controlled by this pedal, which regulates the amount of fuel mixture fed to the engine. Proper operation of it avoids brake applications and ensures fuel economy.

◆ Parking Brake Lever

By pulling this lever firmly upward, parking brakes are applied to both the rear wheels when the gear is engaged in rear wheel drive, but in four wheel drive, to four wheels. To unlock the brakes, push in the button at the top of the lever and push the lever down. If the button is tight, pull the lever up slightly to unlock. It is a good practice to pull the lever up when leaving the vehicle. For anti-theft, parking brake lock is equipped on the base of the parking brake lever. To lock, turn the key clockwise, to unlock, turn the key counterclockwise.

◆ Ventilator Lever

To open the ventilator, push the ventilator lever which is fitted under the instrument panel, and to shut, pull it backward.

◆ Bonnet

Bonnet is fixed by hooks at both sides of front part of bonnet as shown picture. Bonnet is unlocked easily by pulling up the hooks. Lock the both sides hooks after shutting the bonnet.

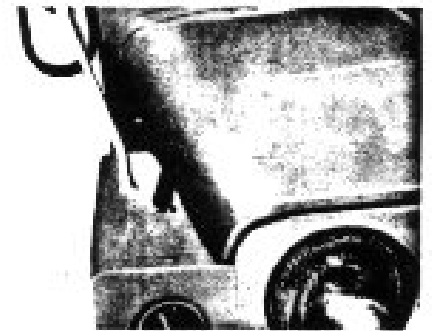
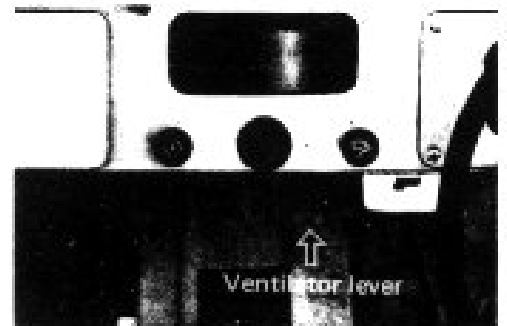

◆ **Tow Hook**

< **Front** >

When it is needed to drag your vehicle to a garage on account of a breakdown, fasten a rope to the tow hook provided on the front center of the framework.

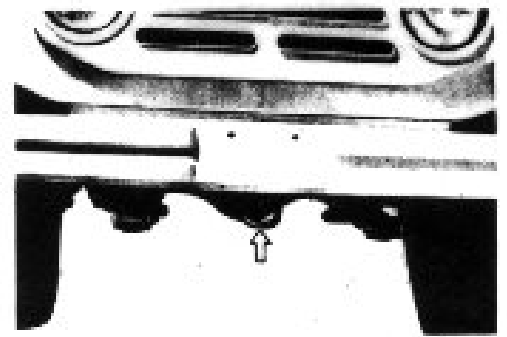

< **Rear** >

Contrariwise, when your vehicle has to take other one in tow, fasten a rope to the tow hook which is provided on the rear center of the framework.

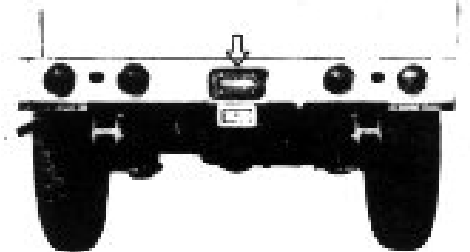

◆ **Fuel Tank**

Fuel tank inlet is located in the rear part of the deck right side panel. To remove the fuel tank cap turn it to the left and to fit it turn to the right.

Use super gasoline with Octane rating 90~100 in Research Method.

Tank Capacity 26 ltr. (6.9/5.7 gal, US/Imp)

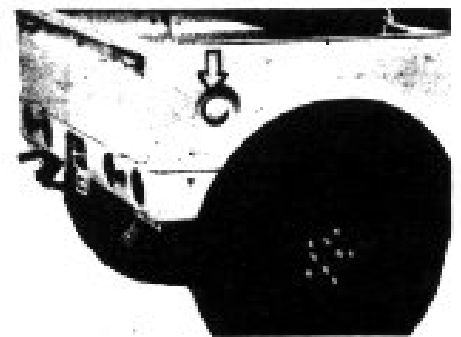

◆ **Oil Tank**

Oil tank is located inside of the engine room. When the oil remainder becomes 0.5 ltr (1.05/0.88 pt, US/Imp), the red oil level warning lamp turns brighter, which calls your attention to replenishing the tank with Suzuki C.C.I. oil or Outboard Motor Oil with around SAE # 30.

◆ **Front Gate Bar**

Front gate bars are equipped at driver's and assistant's seats.

Getting on and off a car, pull the lever (1) as shown picture back, and let the bar down with the lever is pulled. Start the vehicle after confirm that front gate bars are locked securely.

◆ **Rear Gate**

The rear gate can be opened and shut with the lock handle.

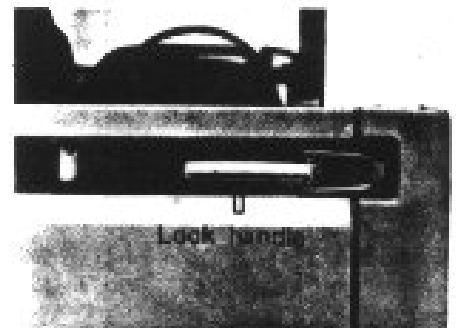
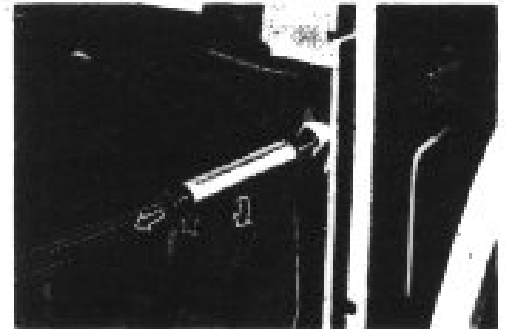

6. INSPECTION BEFORE DRIVING

Proper inspection before every driving will not only keep your vehicle in top condition but also prolong its life.

◆ Steering Wheel

Turning the wheels (tires) straight ahead, check the steering wheel for shimmy and play, etc. The standard steering wheel play should be 10–30 mm (0.4–1.2 in) along the steering wheel. If there is not free play or much play, have your Suzuki dealer check your vehicle.

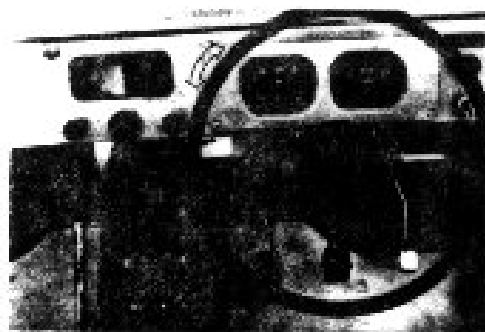

◆ Brake Pedal

There should be 15–20 mm (0.6–0.8 in) free play in the brake pedal before the brakes begin to engage. When the brake pedal is depressed all the way with the brake shoes tight against the drums, there should be a clearance of more than 20 mm (1.2 in) between the head of the brake pedal and the floor.

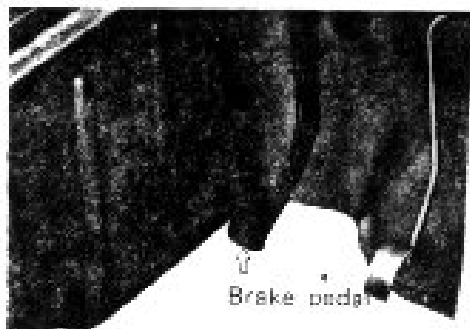

◆ Parking Brake Lever

The parking brake should be applied completely in the middle part (30–60 %) of the parking lever operating range (on below the 7th tooth of the parking lever ratchet) and at the same time the button on the tip of the lever should operate lightly.

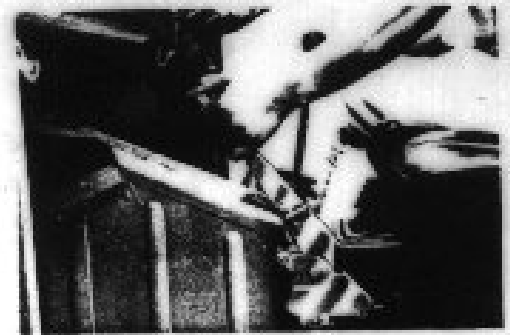

◆ Clutch Pedal

There should be 15–20 mm (0.6–0.8 in) free play in the clutch pedal before the clutch begins to operate. Just like the brake pedal, there should be a clearance of more than 30 mm (1.2 in) left between the head of the clutch pedal and the floor when declutched completely. If the clearance is improper, gear shifting is not done smoothly.

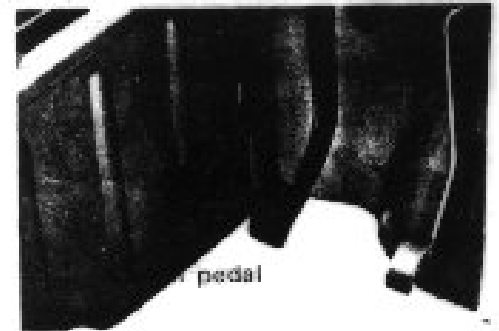

◆ Tire Pressure

Proper tire pressure increases tire life and riding comfort. Maintain air pressure at the standard level according to the following table. Measure tire pressure with an air gauge. Do not forget to fit an air inlet valve cap after measuring tire pressure.

Front tires	1.1 kg/cm ² (15.6 lb/in ²)
Rear tires	1.1 kg/cm ² (15.6 lb/in ²)

Caution: Measure tire pressure at the time when tire is cooled.

◆ Chassis Spring

Check if a chassis spring does not break.

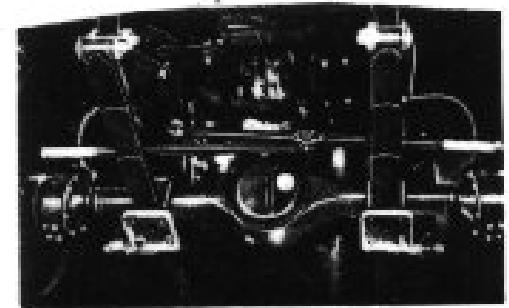
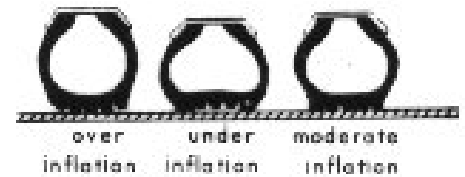
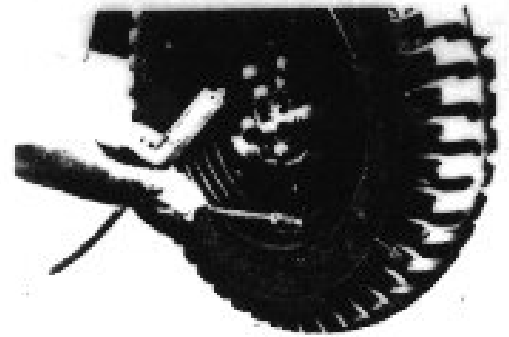

◆ Fuel

Turning on the ignition switch, check the fuel capacity in the tank by reading the fuel gauge. When the needle in the fuel gauge lies at the "E" position, the tank has approximately 3 ltr. (0.80/0.65 gal, US/Imp) of fuel remains at this time.

It is necessary to check the fuel gauge in running.

Tank Capacity	26 ltr (6.90/5.70 gal, US/Imp)
---------------	--------------------------------

◆ Engine Oil

If the remaining volume of engine oil in the tank reaches 0.5 ltr (1.0/0.9 pt, US/Imp), the oil level warning lamp glows brightly, indicating that you must add Suzuki C.C.I. oil or Outboard Motor Oil with around SAE ¹ 30 wt.

◆ Brake Fluid

Check if the brake fluid level is above the ridged line on the oil reservoir. If it is below the ridged line, do not lose time to supply with good-quality brake fluid.

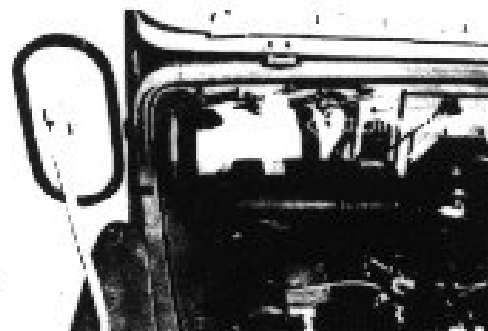

◆ Head Lamp

Check to see if the head lamps turn on normally and head lamp beam angle is changed properly when the dimmer switch lever is operated. Check to see if the right and left beam directions and beam distances are correct. If not make a focus adjustment in the following way. Take off the front grill loosening six fitting screws and adjust by three adjusting screws. The beam angle should be adjusted so that an obstacle located 100 m (300 ft) away can be distinguished when making the beam direction upward and an obstacle located 30 m (100 ft) away can be distinguished when making the beam direction downward.

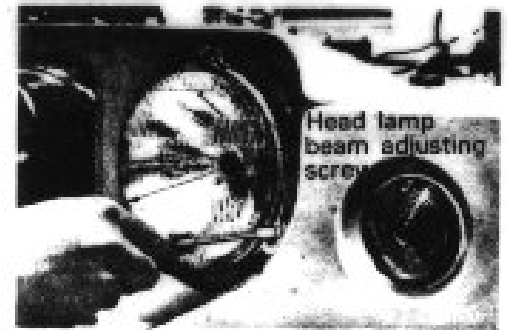

◆ Front/Side Turn Signal Lamps

Check to see if the front and side turn signal lamps flash normally when operating the turn signal indicator switch lever.

Besides, check to see if the front turn signal lamps working as the parking lamp too, light normally when pulling the lighting switch to the first step.



◆ **License Plate Lamp**

Check to see if the license plate lamp turns on by pulling the lighting switch.

◆ **Back-up Lamp**

Check to see if the back-up lamp turns on when shifting gears to reverse with the ignition switch on.

◆ **Rear Turn Signal/Tail/Parking Lamps**

Like the front turn signal lamps check to see if the rear turn signal lamps flash normally when operating the turn signal switch lever.

Inspect if the tail lamp turns on by pulling the lighting switch.

◆ **Brake Lamps**

Check to see if the brake lamp turns on correctly in depressing the brake pedal and turns off instantly in releasing it.

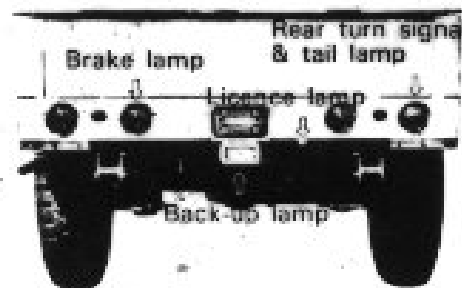

7. SERVICE TOOLS

◆ Service Tool Kit

Tool kit is provided in the glove box taking in and off easily. Glove box can be locked with ignition switch key for anti-theft.

- ① 22 x 19 mm Offset Box Wrench
- ② Box Wrench Handle
- ③ Box Wrench
- ④ 17 x 14 mm
- ⑤ 12 x 10 mm
- ⑥ Pliers
- ⑦ Combination Screw Driver
- ⑧ Jack Handle
- ⑨ Jack
- ⑩ Tool Bag

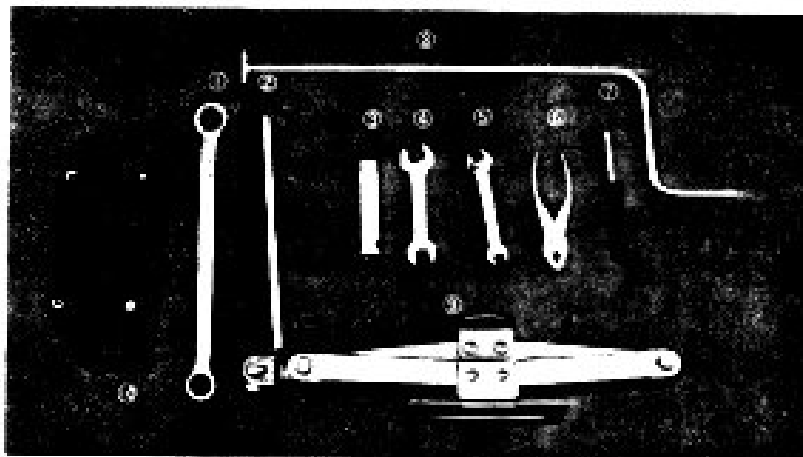

◆ Jack And Jack Handle

Jack and jack handle are set under the driver's seat. Jack handle is removed easily by pulling up. Jack is set by rubber band so jack can be removed by taking off the rubber band.



8. TIRE CHANGE PROCEDURE

◆ Removing Spare Tire

Spare tire is fixed at the back of deck rear gate. Spare tire can be removed by retightening three nut and take off.

◆ Changing Tire

Using offset box wrench in tool kit, retighten outside five nuts among nine nuts, next take off five nuts which are retightened before, and replace the wheel with jacking up.

Tighten nuts securely with jacking down after replacement.

◆ Tire Position Rotation

In order to avoid uneven tire wear, and to lengthen the life of the tires, rotate the position of each tire as shown in the chart at 5,000 km (3,000 mil) intervals.

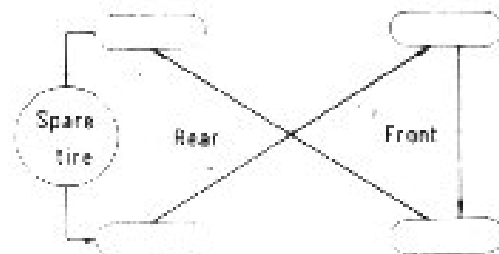
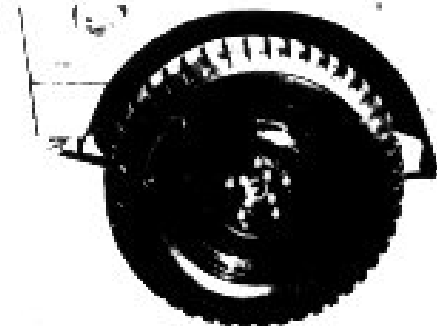
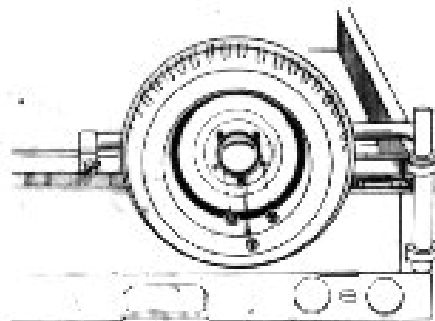

9. EASY INSPECTION, ADJUSTMENT AND MAINTENANCE

A. Engine

◆ Air Cleaner Element

The air cleaner is located to the right of the engine room. Take out the air cleaner element after removing the fitting clips and air cleaner cap.

To clear the air cleaner element, remove away the dust accumulated on it by tapping by hand or using a brush. Clean the element every 5,000 km (3,000 mi) and replace with a new one every 10,000 km (6,000 mi).

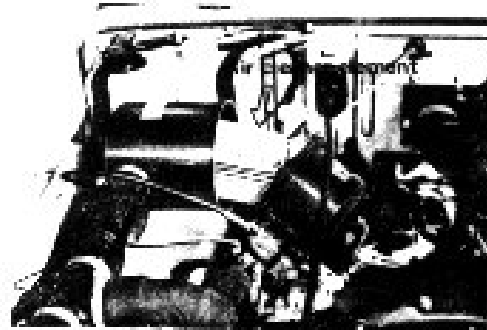

◆ Fuel Filter

The fuel filter is located under the carburetor air inlet hose.

The fuel filter is of anti-disassembling type needing no inspection and cleaning in short covered mileage. Replace with new one every 40,000 km (25,000 mi).

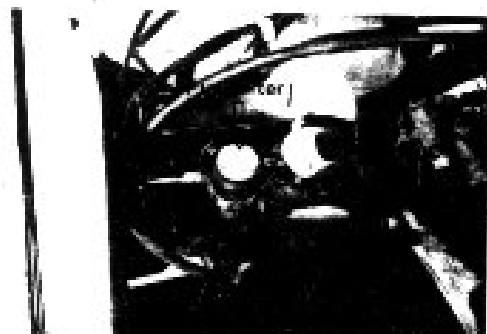

◆ Adjusting Carburetor at Idling

Before adjusting the carburetor, warm up the engine sufficiently with the ignition timing adjusted properly and with the choke lever unused.

- (1) To increase engine speed to some extent screw the throttle valve stop screw in.
- (2) Screw the pilot air adjusting screw in all the way.
- (3) Screw it back gradually and stop turning it out just when the engine revolution becomes highest.
- (4) Screw the throttle valve stop screw out until just before the engine stops.



◆ Adjusting Oil Pump

The oil pump control lever regulates the amount of oil discharged from the oil pump. When adjusting, keeping the accelerator pedal completely released, loosen the oil pump connecting rod locking bolt. Tighten the bolt with the oil pump control lever hitting against the stopper.



◆ Warm Air Control Lever

The warm air control lever is located on the way of the air suction pipe as shown in the picture.

Be sure to slide this lever into "winter" or "summer" position according to season or climate the car is used. Because this is employed to supply the engine with the warm air so as to maintain the combustion process in the engine in good condition at any time.



◆ **Checking oil pump for oil leakage**

If oil leaks from the oil pump, retighten the banjo bolts to the specified torque 35–45 kg-cm. Give a special attention not to overtighten the bolts causing oil to leak again.



◆ **Checking and Cleaning Spark Plug**

The standard gap between the center electrode and side electrode should be 0.6–0.7 mm (0.024–0.028 in). If carbon accumulates on the spark plug, clean off with a pen point or wire, etc.

If the electrode or insulator parts are damaged, replace the plug.

The standard plug for this vehicle is NGK B-7HS.

If unavailable, however, the following spark plugs may be used.

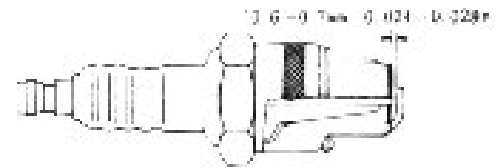

NGK	Champion	AC	Auto-Lite	Bosch	KLG	Lodge	NIPPONDENSO
B-7HS	L5	42FF	AE2	W240T1	F80	2HN, 3HN	W22FS

◆ Inspecting and Adjusting Distributor

Adjusting contact point gap

The standard breaker point gap is 0.4 mm (0.0157 in). If the gap is not standard, loosen the point fitting screw and adjust the gap to the standard with the screw driver inserted in the gap adjusting slot.

Adjusting ignition timing

After loosening the distributor fitting clamp bolt, turn the distributor to the right slightly. Align the timing mark of 16° on the flywheel with the marking protrusion of the crankcase by turning the cooling fan by hand. Remove spark plugs so as to check to see the sparks and to turn the flywheel easily. Connect the first cylinder's spark plug with the high tension cord place it on the engine. Turn on the ignition switch. Next turn the distributor to the left slowly and stop turning it just when the plug sparks. Be sure to fix the distributor by screwing the distributor fitting clamp bolt in. It is necessary to adjust the ignition timing every time when the contact point gap has been adjusted.

◆ Checking Battery

Check the level of electrolyte solution in the battery. The level should always be kept between the upper and lower level lines marked on the battery case. Add distilled water up to the upper limit line if found below the lower limit line. The standard specific gravity of the electrolyte is 1.26–1.28 at 20° C (68° F). When the specific gravity drops below the 1.22, recharge the battery.

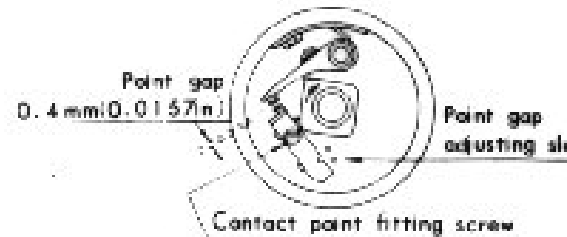

B. Body

◆ Adjusting Brake

First jack up the vehicle and remove the brake adjusting hole cap.

Insert a screw driver through the hole and pry the brake adjuster sleeve outward with the driver using the hole as a fulcrum until the brake shoes contact with the brake drum and the wheel can not be spun by hand.

Next to get a proper clearance between the brake shoes and the brake drum, turn the brake adjuster sleeve inward. The standard turning inward of the sleeve is as follows.

Front wheel 3-6 pitches inward

Rear wheel 4-7 pitches inward

Make sure the brakes engage smoothly and that the brake pedal returns to its original position as soon as it is released. Make sure the brakes act equally on both sides.



◆ **Adjusting Parking Brake**

The adjusting procedures of the parking brake are just the same as those of service brake.



◆ **Inspecting Steering Linkage**

Steering linkage is composed of some rods, tie rod ends and arms. While turning the steering wheel, check to see if the components of the linkage are looser, worn or damaged.



◆ Inspecting Leaf Spring and Shock Absorbers

Check leaf springs and shock absorbers for loosening of fitting bolts and for cracks and damage.

Check the shock absorbers for oil leakage. Replace them if excessive oil leakage is found.

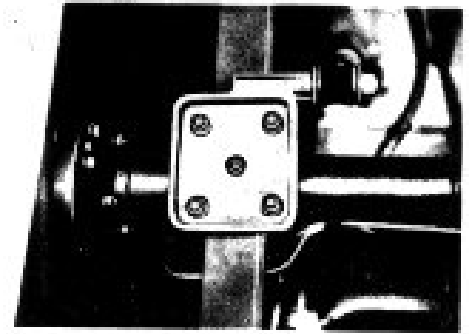

◆ Adjusting Clutch Pedal Play

The standard clutch pedal play should be 15–20 mm (0.6–0.8 in) before the clutch begins to operate.

If the clutch pedal play is too small, clutch slippage is apt to occur and the clutch release bearing may be damaged, on the contrary, when the clutch play is too large, the clutch becomes difficult to be disengaged.

If improper play is found, adjust with the clutch cable adjusting nut.

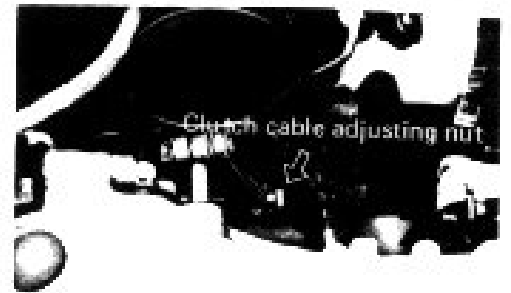

C. Bulb Replacement

◆ Head Lamp

The head lamp is of a sealed beam type. If the filament is burnt out, it is necessary to replace the head lamp in a unit. When replacing, push and twist the head lamp, and it'll be taken off easily.

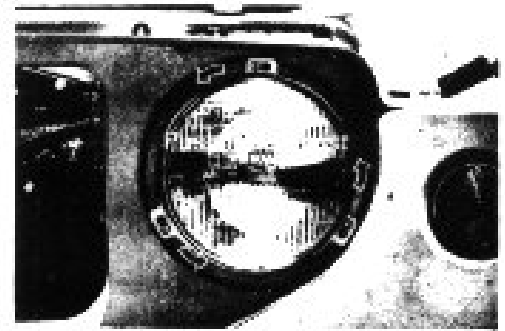

◆ Front Turn Signal/Parking Lamps

To replace the bulbs, first loosen the three fitting screws and remove the lens.

Then unscrew the bulb by pressing it slightly in and counter-clockwise.

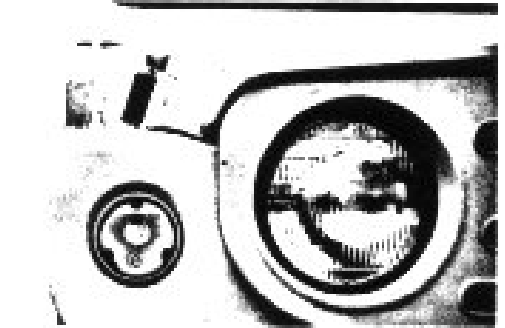

◆ **Side Turn Signal Lamp**

Unscrew the two outer lens screws. After the lens is off, unscrew the bulb by pressing it slightly in and turning counter-clockwise.

Caution: When fitting the lens screws, be sure to set the earth plate together with the outer lens to ground the bulb.



◆ **Rear Turn Signal/Tail/Parking Lamp**

Remove the lens by unscrewing the three lens fitting screws. Turn the bulb counter-clockwise pressing slightly inward and it can be taken off.

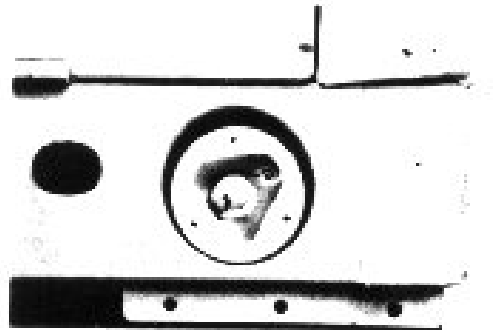

◆ **Brake Lamp**

Replace the bulb by unscrewing the three outer screws.

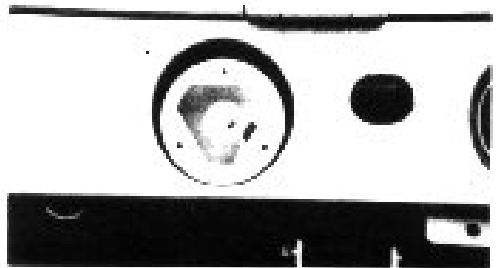

◆ **License Lamp**

By removing the two outer screws, the light body and lens can be taken off. To remove the bulb, press it slightly inward and turn counter clockwise.

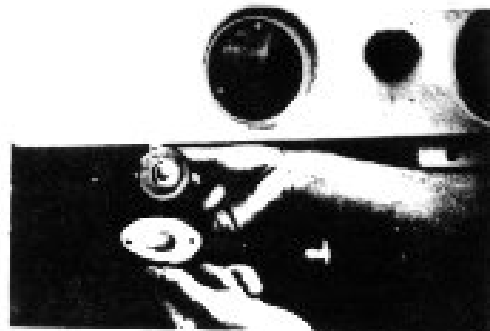

◆ **Back-up Lamp**

Remove the two lens fitting screws first to take off the lamp. Next turn the bulb counter-clockwise pushing slightly inward.



◆ **Room Lamp**

To remove the bulb, push the lens by fingers from right and left and take it off.

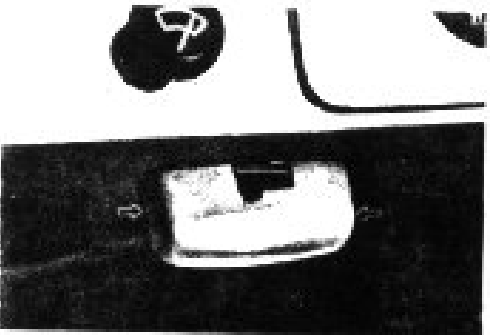

◆ Bulbs In Combination Meter

The bulbs are fitted into the under surface of the combination meter box as shown in the photograph. Turn the knob a little to the left and it will be removed.

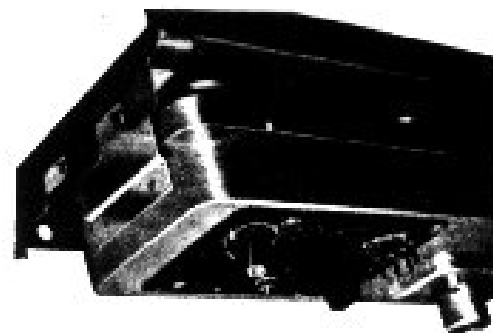

D. Fuse

◆ Fuse Box

The fuse box is installed beneath the steering shaft bracket.

◆ Fuses

Remove the fuse box cap by pulling it toward you and three fuses will be found in the fuse box.

• Be sure to use the specified fuse for safety.

If a fuse bigger than the specified in amperage or a wire is ill-advisedly used, it will be the cause of a fire. If a new specified fuse is burnt out as soon as replaced, the electric circuit is supposed to be short.

Please have your Suzuki dealer check and repair your vehicle.

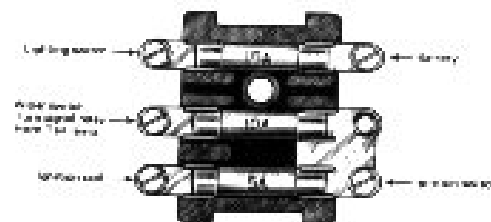
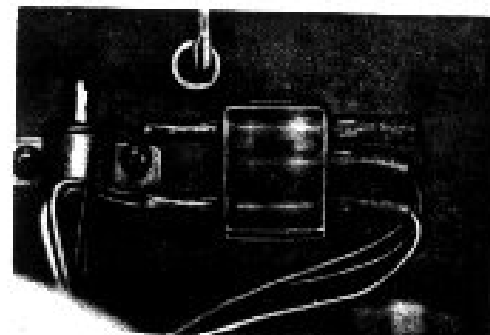

E. Oil Charge or Replenishment

◆ Transmission Oil

The transmission oil filler plug is located on the transmission case as shown in the photo. Turn the oil filler plug counterclockwise to remove and pour oil in through the hole.

Specified oil amount . . . 0.8 ltr (0.8/0.7 qt, US/Imp)



◆ Differential Oil (Front & Rear)

Check to see if the oil is filled up to the oil inlet after removing the oil level inspection plug.

If the oil is found short, replenish without losing time. When changing the oil, remove the drain plug and drain all the used oil. Replace the oil drain plug and pour oil in through the oil level inspection hole until it runs out of the hole.

Specified oil amount (front & rear) . . . 0.8 ltr (0.8/0.7 qt, US/Imp)

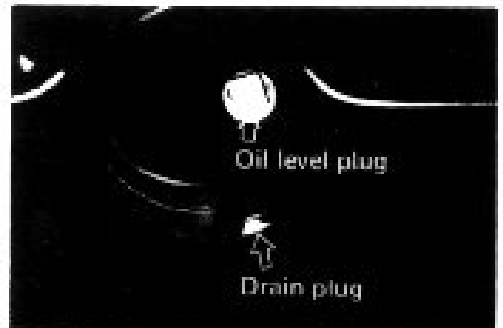

◆ **Steering Gear Box Oil**

Check to see if the oil is kept up to the oil inlet after removing the oil filler plug. If the oil amount is insufficient, add gear oil.

Specified oil amount190 cc (6.4/6.7 OZ, US/Imp)

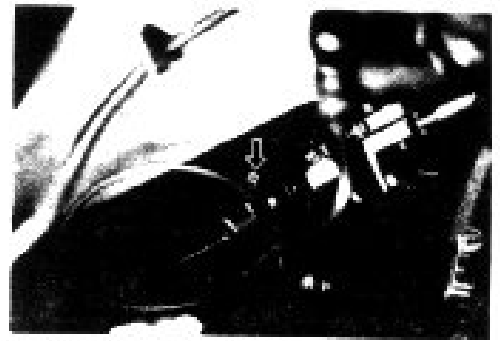

◆ **Brake Fluid**

Check the level of the brake fluid in the reservoir located in the engine room.

Always keep the fluid level above the ridged line on the oil reservoir.

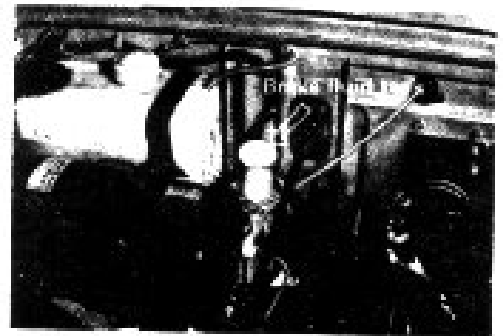

◆ **Engine oil**

Engine oil tank is positioned in the engine room. If the oil level warning lamp grows brightly, it indicates remaining volume of engine oil reaches 0.5 ltr (1.0/0.9 pt, US/Imp).

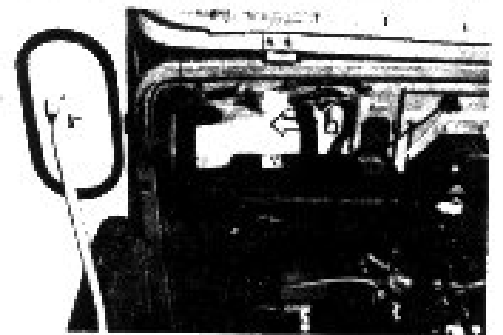

10. TROUBLE SHOOTING

It is recommended that you make emergency repairs first and then have your Suzuki dealer check and fix fundamentally when you have an engine trouble.

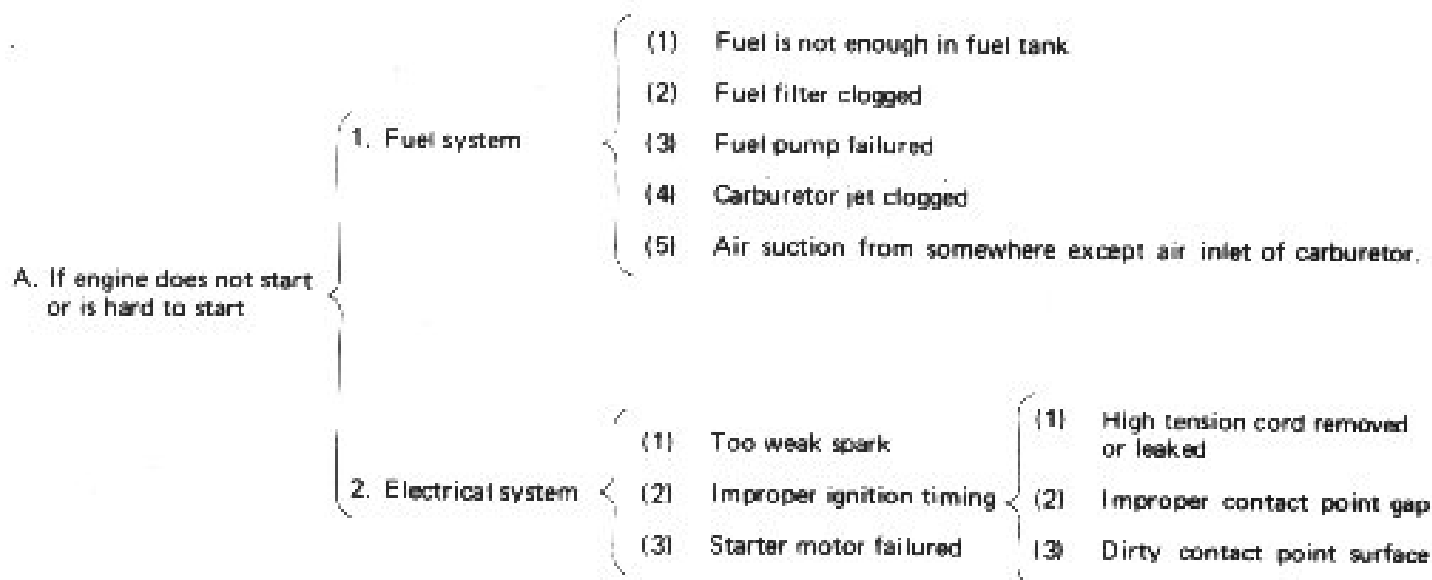

- | | | | |
|-----------------------|-----|--|--|
| 1. Powerlessness | (1) | Lower compression pressure in cylinder | Loose cylinder head
Cylinder wear
Piston excessively work
Piston ring excessively worn |
| | (2) | Improper ignition timing | |
| | (3) | Carburetor failed | |
| | (4) | Foreign matter mixed in fuel | |
| | (5) | Under-inflated tire | |
| | (6) | Clutch slippage | |
| | (7) | Exhaust system clogged | |
| | (8) | Crank oil seal damaged | |
| 2. Engine noise | (1) | Detonation knock | Low octan fuel used
Ignition timing too advanced
Carburetion too lean
Piston excessively worn
Connecting rod small end and/or big end excessively worn |
| | | Mechanical knock | |
| 3. Engine overheating | (1) | Improper ignition timing | |
| | (2) | Carbon accumulated | |
| | (3) | Oil pump does not work properly | |
| | (4) | Engine overloaded | |
| | (5) | Carburetion too lean | |
| 4. Mis-Fire | (1) | Spark jumps irregularly from spark plug | |
| | (2) | Dirty or burnt spark plug | |
| | (3) | Contact point failure | |
| 5. Joggle | (1) | Main or pilot jet clogged with water or foreign matter | |
| | (2) | Enough fuel does not supplied to carburetor | |

C. If battery is not charged enough

- (1) Insufficient battery solution
- (2) Battery failed
- (3) Wiring poorly contacted
- (4) Voltage regulator failed
- (5) Starter generator failed
- (6) Improper specific gravity of battery solution

11. HOW TO STRETCH THE SOFT TOP (OPTION)

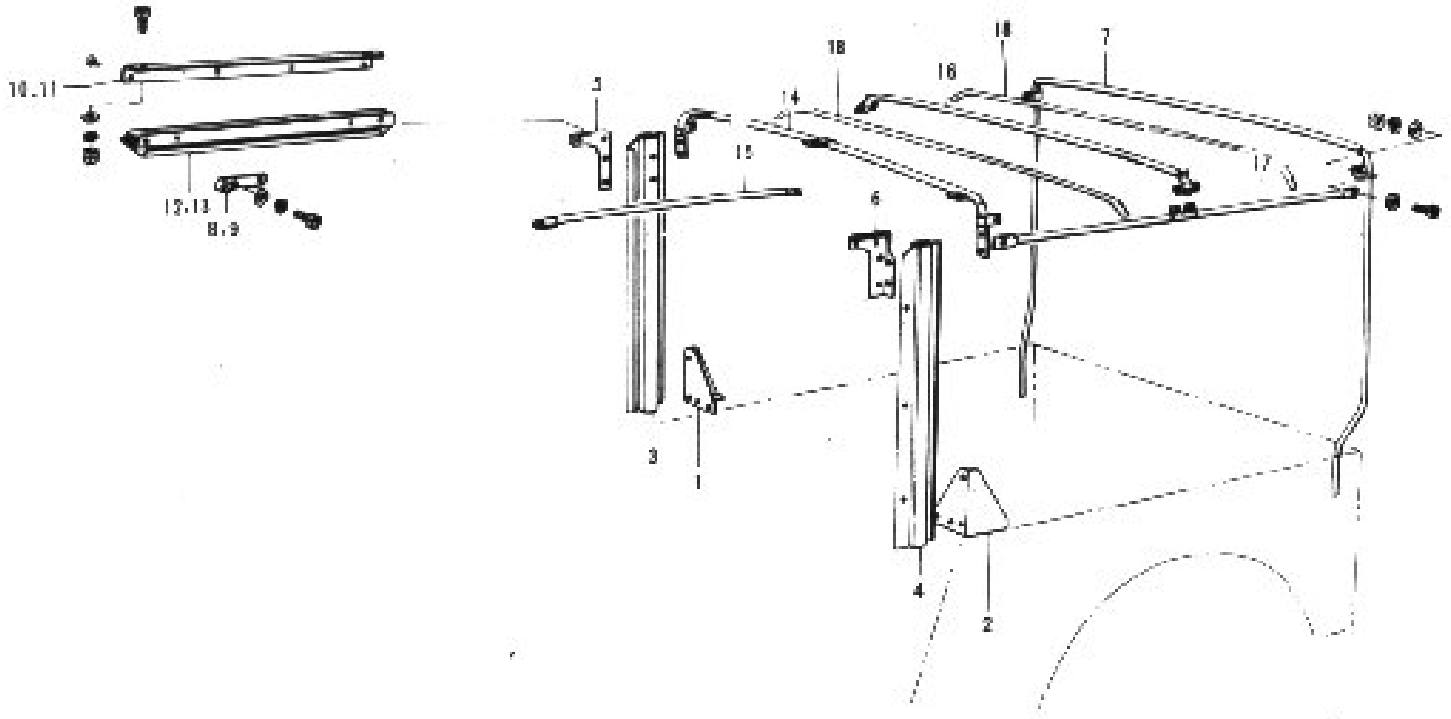

◆ **First assemble the frame of the soft top.**

When installing the frame of the soft top to the vehicle in the following procedures, first tighten all the bolts lightly and then secure after all of them can be secured in position.

1. Assemble the center pillar brackets (1, 2) and roof side rail brackets (5, 6) with the center pillars (3, 4).
2. Install the center pillars on the front corners of the front deck.
3. Install the rear cross top bow (7) on the rear part of the deck.
4. Assemble the roof side rail front brackets (8, 9) and deck top front side rails (10, 11) with the roof side rails (12, 13).
5. Joint the assembled roof side rails with the roof side rail brackets and front window top bracket.
6. Install the front cross top bow (14) on the center pillars.
7. Joint the front top rail (15) to the front cross top bow and front window top brackets.
8. Assemble the middle cross top bow (16) with the rear side rail No. 1 (17).

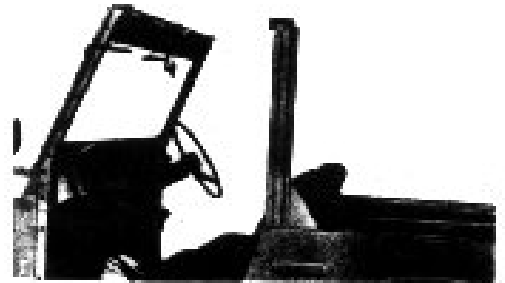

9. Assemble the cross top bow No. 2 (18) to the rear side rail No. 1 and rear side rail No. 2,
10. Joint the assembled middle cross top bow and rear side rail No. 1 to the front cross top bow and rear cross top bow respectively.

Note: Finally hook the rear side rail No. 2 on the middle cross top bow.

Be careful not to install the right parts to the left and vice-versa, as these are apt to be confused.

◆ **Next install the canvas door**

1. Fix the hinge female on the lower part of the side panel first,
2. Insert the lower spindle bar of canvas door into the hinge female,
3. Finally fix the upper hinge to the front windshield body with the upper spindle bar of door canvas in it,

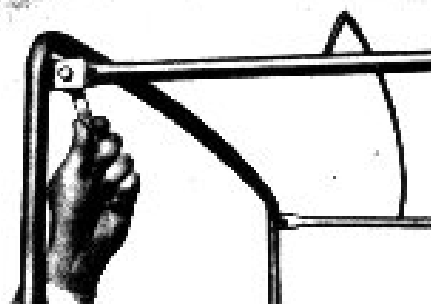

◆ **Next stretch the soft top on the frame.**

1. Pass the hem of the soft top in the slit of the front window. As regards the side hems of soft top, be sure to pass the right and left simultaneously.
2. When stretching the rear curtain, pass the hem into the slit and tie the rope to the frame.

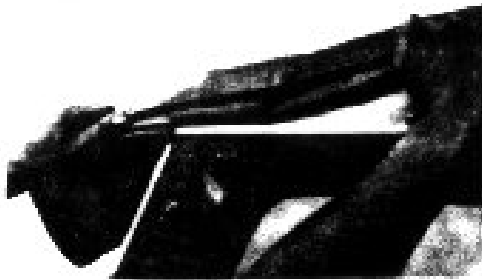
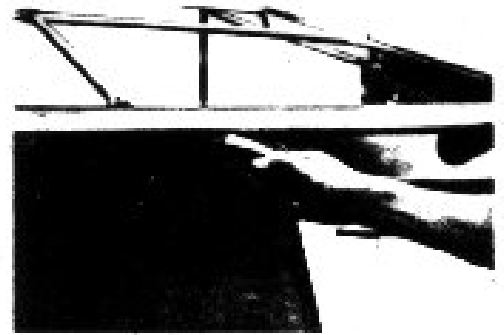

◆ **Front Windshield Set Band**

- Be sure to fix the front windshield with the set band
- run bringing down the front windshield

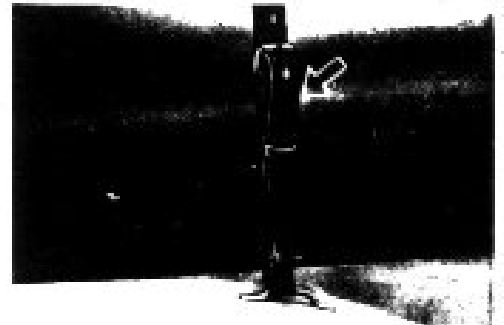

12. MAIN DIMENSIONS

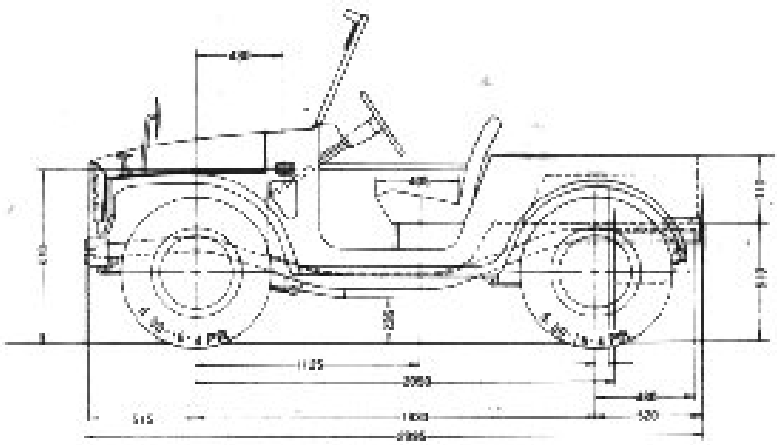
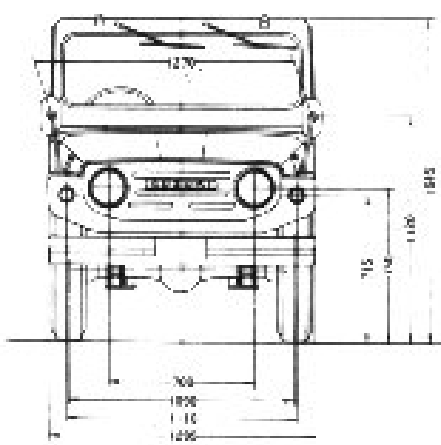
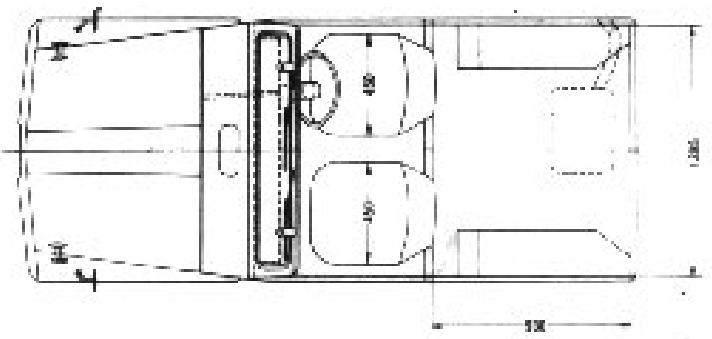
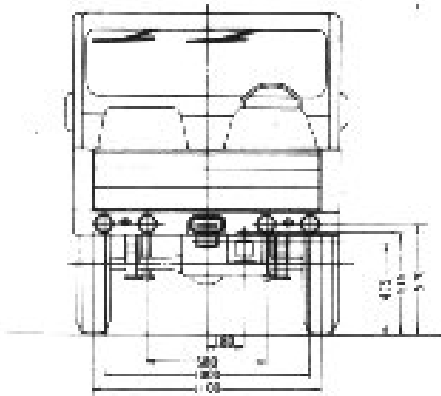

◆ LUBRICATION SYSTEM

Engine lubrication Suzuki C.C.I.
 Oil tank capacity 3.5 ltr. (0.9/0.8 gal, US/Imp)
 Gear box oil capacity 0.8 ltr. (0.8/0.7 qt, US/Imp)

◆ IGNITION SYSTEM

Spark plug NGK B-7HS
 Ignition Battery
 Ignition timing 16° BTDC (1.30~1.67 mm)

◆ TRANSMISSION

Clutch Dry, single disc
 Gears 4 forward, 1 reverse, all synchromesh
 Gear shifting Floor shift
 Gear ratio
 low 3,967 (34/12)
 second 2,388 (29/17)
 third 1,527 (24/22)
 top 1,000
 reverse 3,967 (34/12)
 Final reduction ratio 5,667 (16/34)
 Transfer case (High) 1,714
 (Low) 3,013
 Overall reduction ratio High Low
 (low) 38,529 67,730
 (second) 23,198 40,778
 (third) 14,835 26,078

(top)	9,713	17,074
(reverse)	38,529	67,730

◆ SUSPENSION SYSTEM

Suspension, front Semi-elliptic, leaf spring
 rear Semi-elliptic, leaf spring
 Shock absorber, front Telescopic, double action
 rear Telescopic, double action

◆ STEERING

Type Ball screw nut type
 Steering angle, inner 33°
 outer 28°
 Toe-in 2~6 mm (0.079~0.236 in)
 Camber 1°
 Caster 4°
 Trail 24 mm (0.94 in)
 King pin angle 9°
 Turning radius 4,400 mm (14.4 ft)

◆ Brakes

Foot operated brake Hydraulic, four wheels
 Hand operated brake Mechanical, propeller shaft
 Brake shoes, front Two leading shoes
 rear Leading and trailing shoes

◆ ELECTRICAL EQUIPMENT

Generator	Starter generator
Battery	Type 12N 24-3, 12V 24AH
Head lamp	12V 50/40W
Parking/tail/turn signal lamp	12V 3.4/8/23W
Brake lamp	12V 23W
License lamp	12V 10W
Combination meter lamp	12V 3.4W
Room lamp	12V 5W
Main fuse	20A
Fuses in fuse box	15A, 10A, 5A
Back-up lamp	12V 10W

* Specifications subject to change without notice.

14. PERIODICAL INSPECTION

Items	Interval	First 1,000 km (600 mi)	Every 5,000 km (3,000 mi)	Every 10,000 km (6,000 mi)
Spark plugs		Check & clean	Check and clean	Replace
Contact point & Ignition timing		Adjust	Adjust	
Air cleaner element			Clean	Replace
Oil pump & oil pipe		Check leakage	Check leakage	Check & adjust
Carburetor		Adjust idling	Adjust idling & Throttle cable	
Clutch		Check	Adjust cable	
Fuel filter				Replace every 40,000 km (25,000 mi)
Foot brake			Adjust shoe clearance	
Brake pipe		Check leakage	Check leakage	
Wheel & hub nut		Tighten	Check	
Tire			Change the position	
Wheel alignment			Check & adjust	

15. LUBRICATION CHART



Distributor gear

GO Every 10,000km (6,000mi)



Steering knuckle joint

GO Every 10,000km (6,000mi)
Check oil level



Front differential case

GO Every 10,000km (6,000mi)

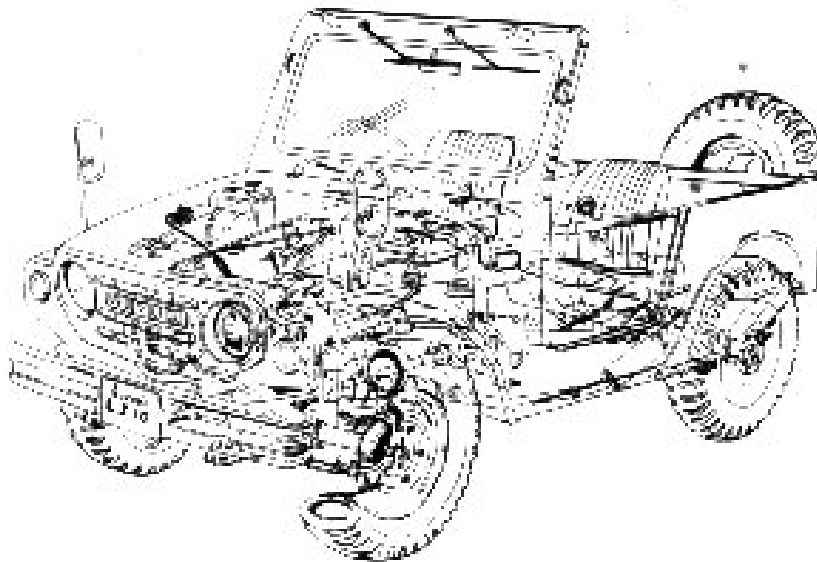

Transmission case

GO First 1,000km (600mi)
Every 5,000km (3,000mi)



Rear wheel end

GO Every 2,500km (1,500mi)



Sliding yoke

GO Every 2,500km (1,500mi)



Transfer case

GO First 1,000km (600mi)
Every 5,000km (3,000mi)



Sliding yoke

GO Every 2,500km (1,500mi)

NOTE:

(GO) Use oil
(GD) Check grease
(*GI) Recommended Grease
Super grease C (Shell)
Altera grease No. 3 (Shell)
Nepal Grease No. 3 (Caltex)
Mobilux No. 3 (Mobil)
Anadol C (Esso)
Cup grease No. 280

(*EPC) Recommended EP Grease
& Shell EP2 (Shell)
Mullpak EP2 (Caltex)
Mobilux No. 3 (Mobil)
Nihara EP2 (Esso)



Rear differential case

GO First 1,000km (600mi)
Every 5,000km (3,000mi)



Universal joint

(*EPC) Every 6,000km (3,000mi)

15. LUBRICATION CHART

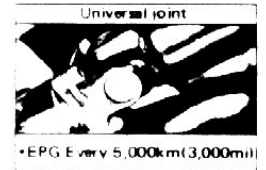
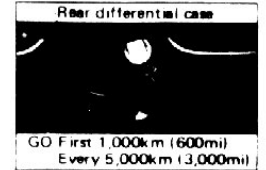
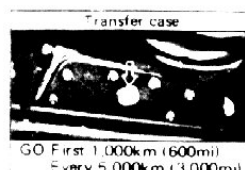
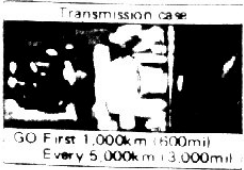
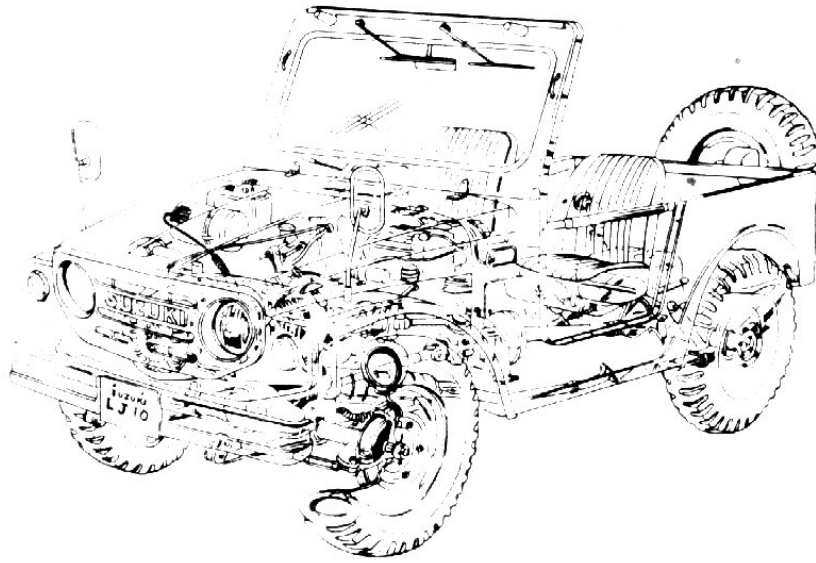
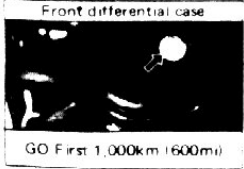
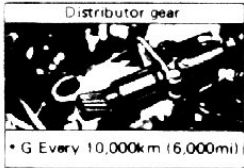

NOTE:

- (GO) Gear oil
- (CG) Chassis grease
- (*G) Recommended Grease
 - Super grease C (Suzuki)
 - Albena grease No. 3 (Shell)
 - Regal Starfak No. 3 (Caltex)
 - Mobilux No. 3 (Mobil)
 - Andok C (Esso)
 - Cup grease No. 250
- (*EPG) Recommended EP Grease
 - Albena EP2 (Shell)
 - Multifak EP2 (Caltex)
 - Mobilplex No. 2 (Mobil)
 - Nebuta EP2 (Esso)

16. WIRING DIAGRAM

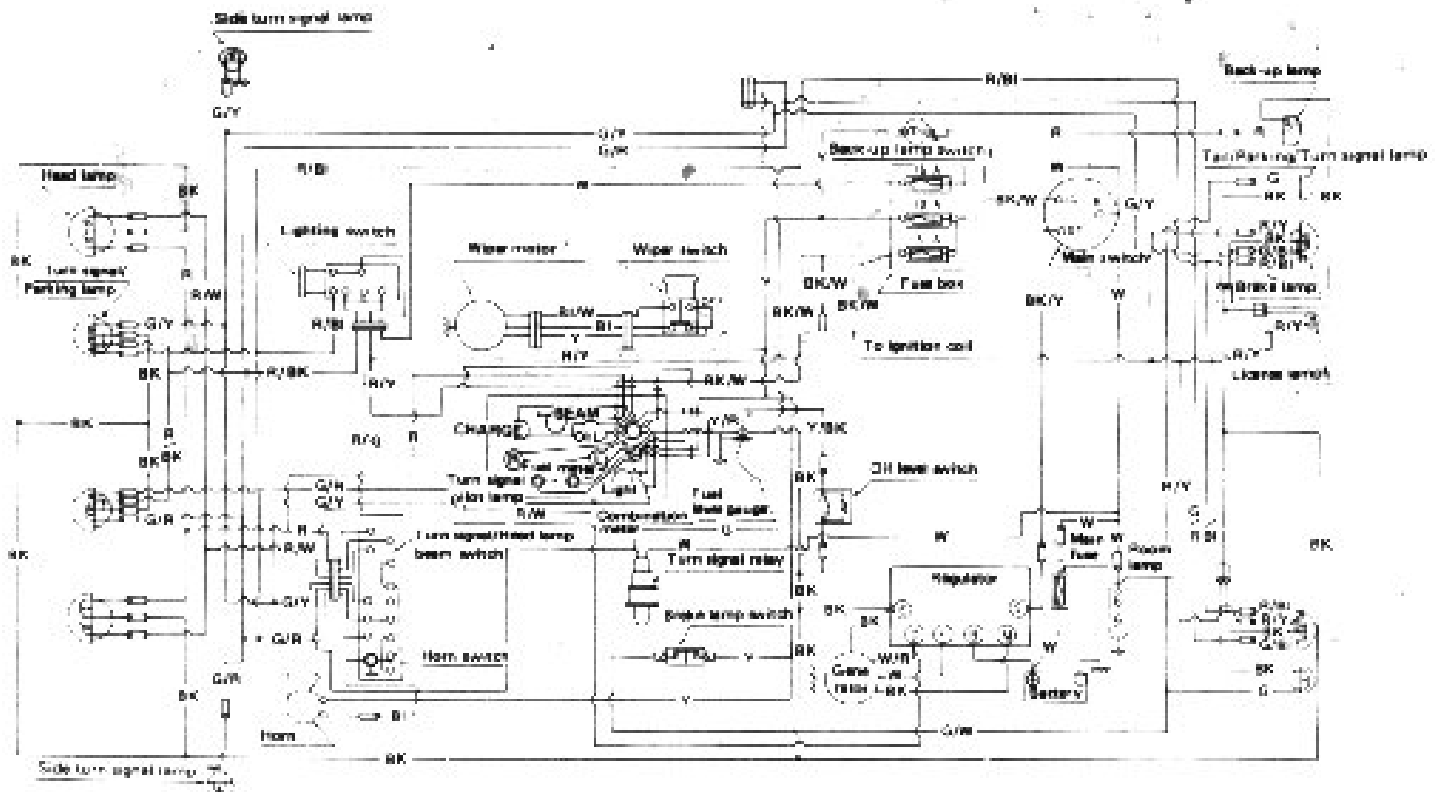

Head lamp	12V 50/40W
Turn signal/Parking lamp	12V 8W
Side turn signal lamp	12V 6W
Speedometer lamp	12V 3.4W x 6
Room lamp	12V 5W
Back-up lamp	12V 10W
License lamp	12V 10W
Brake lamp	12V 23W
Turn signal/Tail lamp	12V 23/8W
Parking lamp	12V 3.4W
Main fuse	20A
Fuses in fuse box	15A, 10A, 5A

W: White	R/Y: Red with Yellow tracer
R: Red	G/BI: Green with Blue tracer
Y: Yellow	BK/W: Black with White tracer
G: Green	R/W: Red with White tracer
BK: Black	R/BK: Red with Black tracer
BI: Blue	
Y/R: Yellow with Red tracer	
G/R: Green with Red tracer	
G/Y: Green with Yellow tracer	
R/BI: Red with Blue tracer	

17. TIGHTENING TORQUE OF IMPORTANT PARTS

It is necessary to retighten these items as shown below every 3,000 km (2,000 mi).
Have your car check to your Suzuki dealer.

Item	Q'ty	Tightening Torque (Kgm)
Nut, plate spring shackle	8	250~ 700
Nut, spring	4	400~ 800
Nut, U bolt	16	300~ 450
Nut, wheel	20	500~ 800
Nut, front wheel shaft	2	1500~ 2700
Nut, rear hub	8	500~ 800
Bolt, king pin	16	200~ 300
Nut, steering rubber joint	4	150~ 250
Bolt, rubber joint flange	2	300~ 400
Bolt, steering gearbox	3	700~ 900
Bolt, gear-box stay	1	350~ 550
Nut, rear backing plate	8	180~ 280
Bolt, cross joint flange yoke	24	150~ 250