

SECTION 11

CLUTCH

CONTENTS

11-1. GENERAL DESCRIPTION	11-2
11-2. REMOVAL	11-4
11-3. INSPECTION OF COMPONENTS	11-5
11-4. INSTALLATION	11-7
11-5. MAINTENANCE SERVICES	11-8
11-6. RECOMMENDED TORQUE SPECIFICATION	11-10

11-1. GENERAL DESCRIPTION

The clutch is a diaphragm-spring clutch of a dry single disc type. The diaphragm spring is of a tapering-finger type, which is a solid ring in the outer diameter part, with a series of tapering fingers pointing inward. The disc, carrying four torsional coil springs, is slidably mounted on the transmission input shaft with a serration fit.

The clutch cover is secured to the flywheel, and carries the diaphragm spring in such a way that the peripheral edge of the spring pushes on the pressure plate against the flywheel (with the disc in between), when the clutch release bearing is held back: This is the engaged condition of the clutch.

Depressing the clutch pedal causes the release bearing to advance and push on the tips of the tapering fingers of the diaphragm spring. When this happens, the diaphragm spring pulls the pressure plate away from the flywheel, thereby interrupting the flow of drive from flywheel through clutch disc to transmission input shaft.

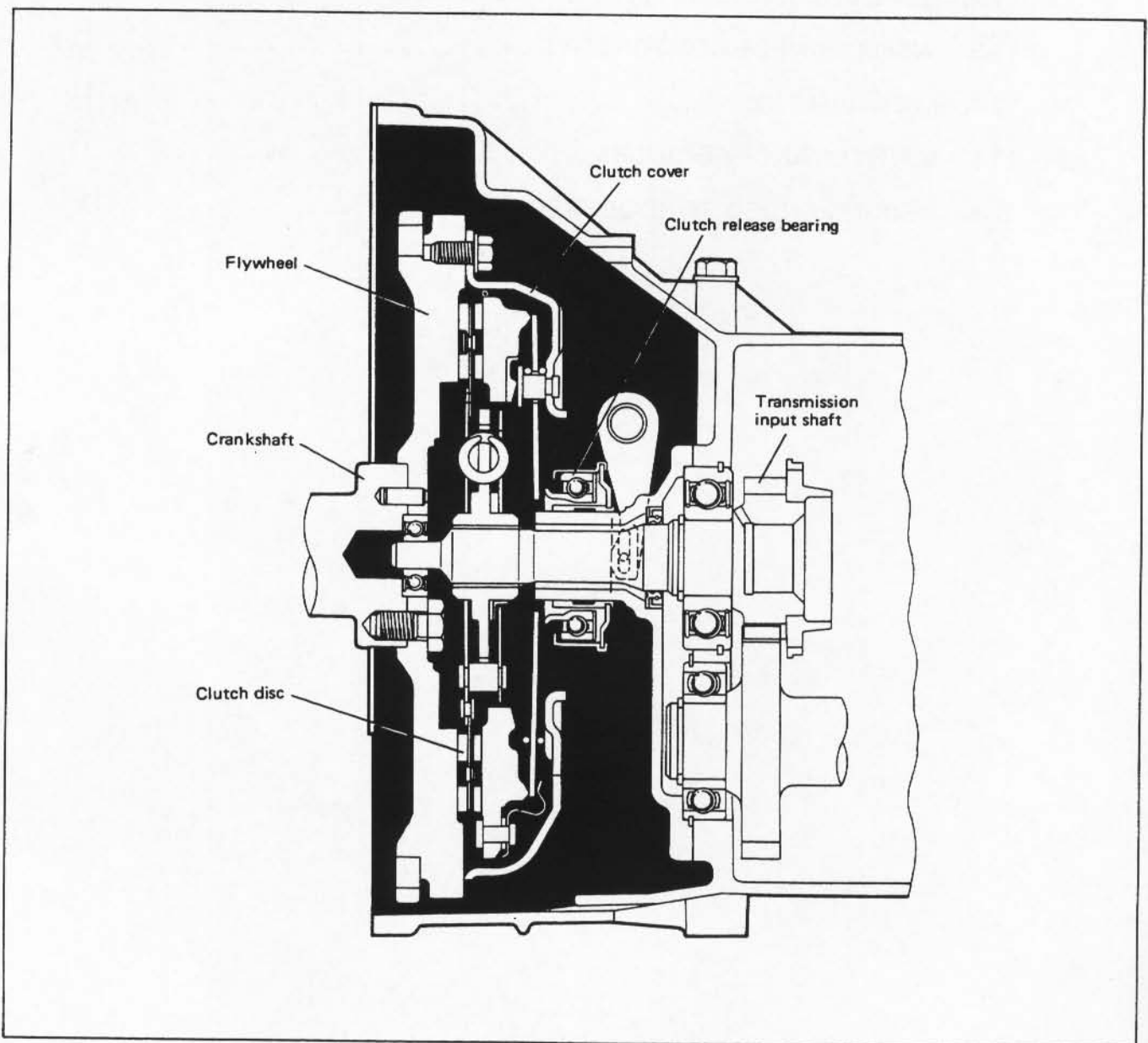

Fig. 11-1

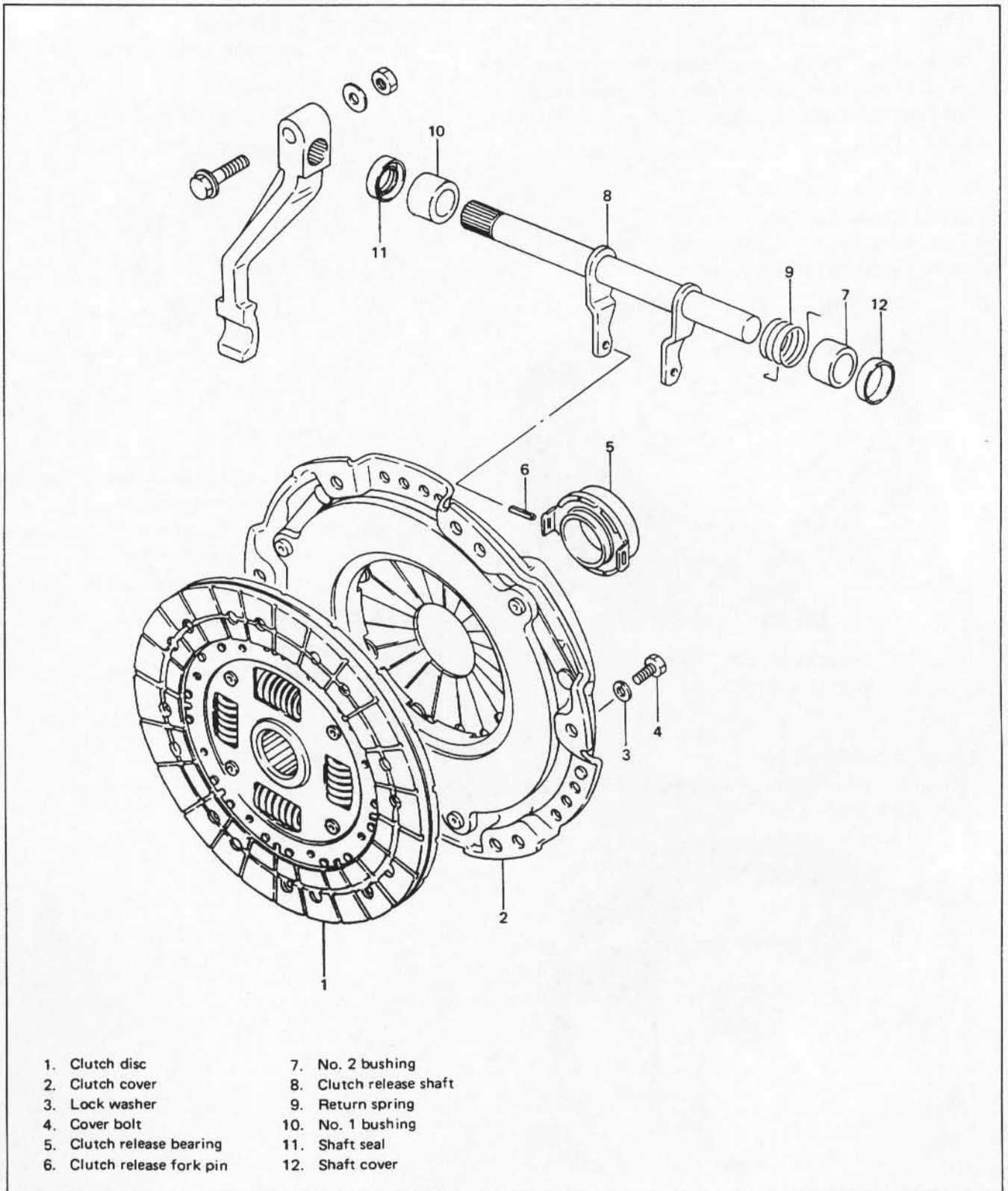

Fig. 11-2

11-2. REMOVAL

Removal of clutch presupposes that the transmission has been dismantled according to the method outlined in SECTION 13 TRANSMISSION.

Clutch Cover and Disc

Remove 6 bolts securing clutch cover to flywheel, and take off clutch cover and disc.

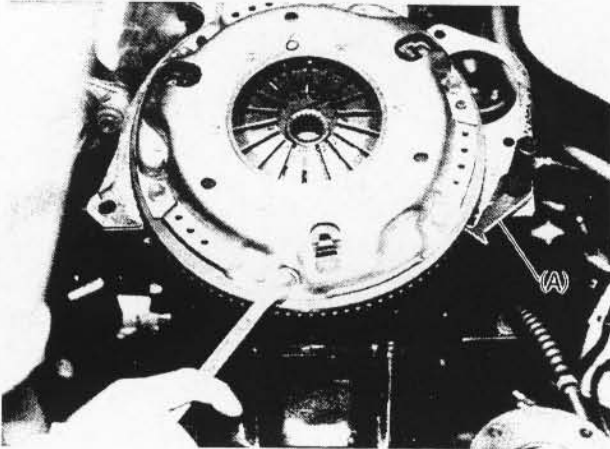

Fig. 11-3 Ⓐ Special tool (Flywheel holder 09924-17810)

Clutch Release Bearing

Remove clutch release bearing from transmission input shaft bearing retainer.

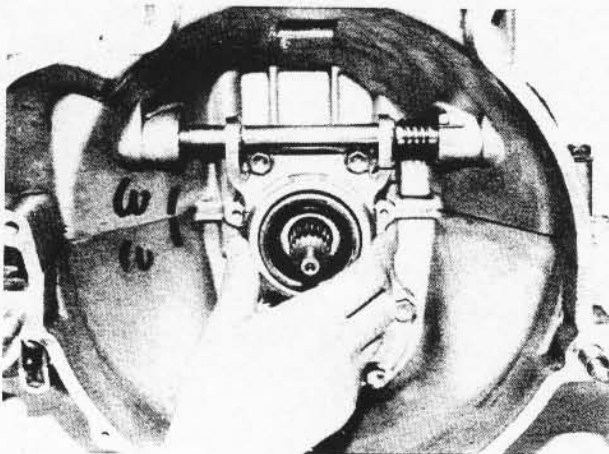
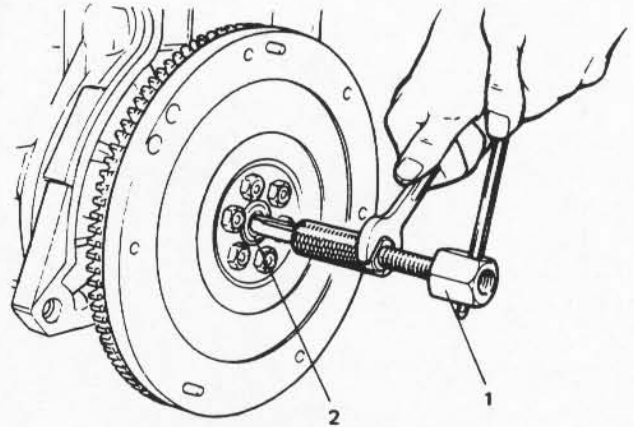

Fig. 11-4

Input Shaft End Bearing

Use bearing remover (special tool) for removal of this bearing.



1. Special tool (Bearing remover 09917-58010)
2. Input shaft bearing

Fig. 11-5

Clutch Release Shaft Bushes

For replacement of bushes, refer to p. 13-5 of SECTION 13 TRANSMISSION.

11-3. INSPECTION OF COMPONENTS

Clutch Disc Facing Surface Condition

A burnt or glazed (glass-like surface) facing can be reconditioned by grinding it with No. 120 – 200 sandpaper. If surface is in bad condition beyond repair, replace whole clutch disc assembly.

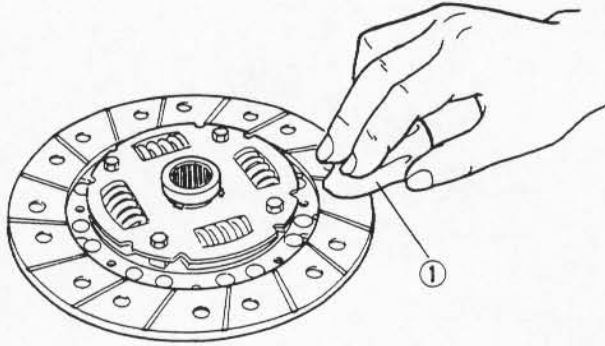

Fig. 11-6 ① Sandpaper

Clutch Facing Wear

Check wear of facing by measuring depth of each rivet head depression, i.e. distance between rivet head and facing surface. If depressing is found to have reached service limit at any of the holes, replace clutch disc assembly.

Rivet head depression	Standard	Service limit
	1.2 mm (0.05 in.)	0.5 mm (0.02 in.)

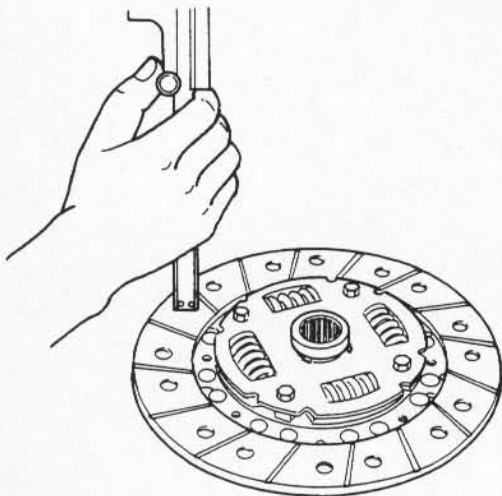

Fig. 11-7

Backlash in Disc Serration Fit

Check backlash by turning disc back and forth as mounted on transmission input shaft. Replace disc assembly if backlash is noted to exceed service limit. Backlash here is a circular displacement as measured with a dial indicator.

Backlash in serration fit	Service limit
	0.8 mm (0.03 in.)

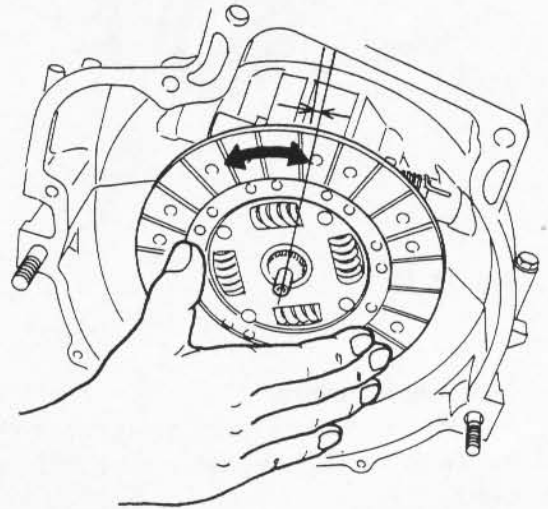

Fig. 11-8

Clutch Cover

Inspect clutch cover for evidence of diaphragm spring rivets getting loose. If rivets are loose or are getting loose, replace cover assembly as such cover makes rattling noise when clutch pedal is depressed.

Inspect tips of tapering fingers (to which the release bearing exerts a push to disengage clutch) for wear. If tips are worn excessively, replace cover assembly.

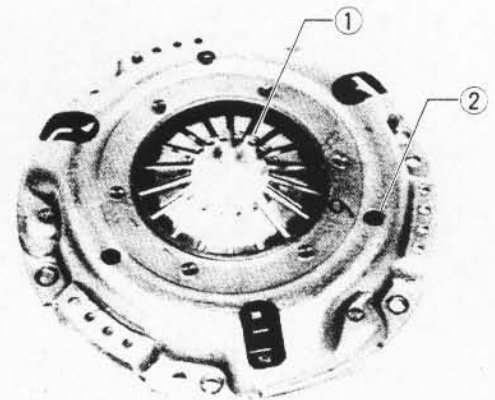

Fig. 11-9 ① Spring wear; ② Rivet

Release Bearing

Replace release bearing if it sticks, rattles or makes abnormal noise when spun and turned by hand.

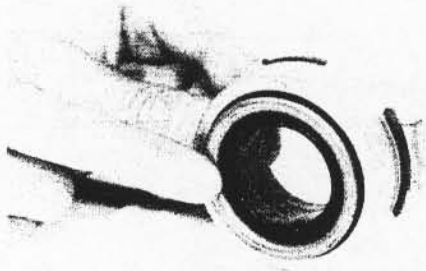

Fig. 11-10

Flywheel

Check surface contacting clutch disc for any wear or damage.

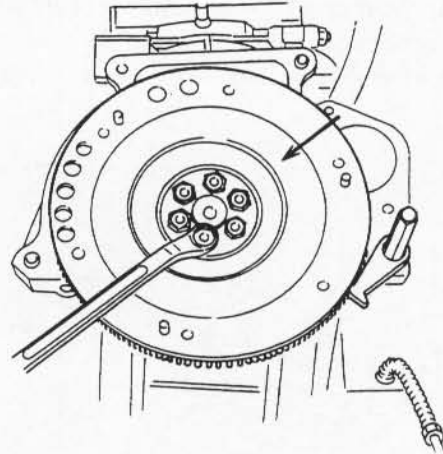

Fig. 11-12

Input Shaft Bearing

Replace input shaft bearing if it sticks, rattles or makes abnormal noise when spun and turned by hand.

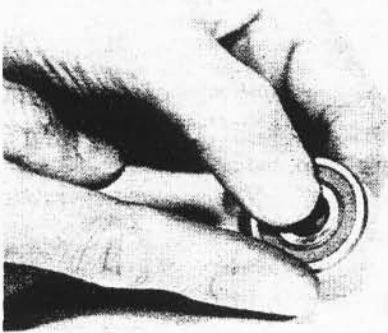

Fig. 11-11

11-4. INSTALLATION

Install clutch by reversing removal procedure. Some important steps will be explained below.

Flywheel

1) Tighten bolts to specification.

Tightening torque for flywheel bolts	N-m	kg-m	lb-ft
	57 – 65	5.7 – 6.5	41.5 – 47.0

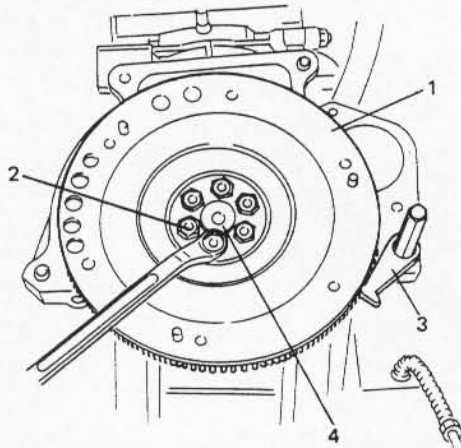

1. Flywheel
2. Flywheel bolt
3. Special tool (Flywheel holder 09924-17810)
4. Input shaft bearing

Fig. 11-13

2) Install input shaft end bearing to flywheel using bearing installer (special tool).

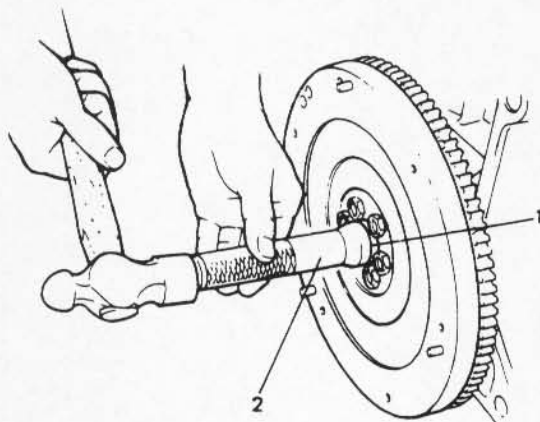

1. Input shaft bearing
2. Special tool (Input shaft bearing installer 09925-98210)

Fig. 11-13-1

Clutch Disc and Clutch Cover

Using special tool (clutch center guide), install clutch disc and clutch cover.

Tighten clutch cover bolts to specification using special tool (Flywheel holder).

Tightening torque for clutch cover bolts	N-m	kg-m	lb-ft
	18 – 28	1.8 – 2.8	13.5 – 20.0

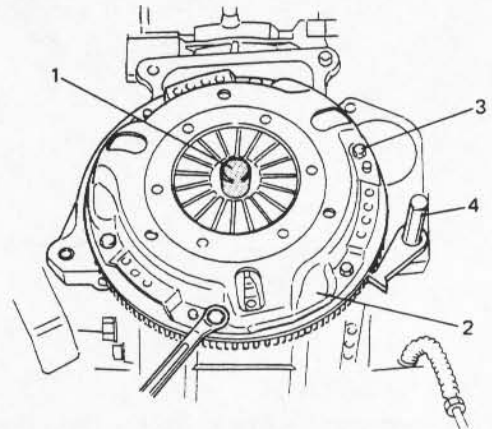

1. Special tool (Clutch center guide 09923-38220)
2. Clutch cover
3. Clutch cover bolt
4. Special tool (Flywheel holder 09924-17810)

Fig. 11-14

Clutch Release Bearing

Before installing retainer, apply grease to its inner surface.

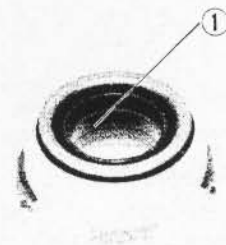

Fig. 11-15 ① Grease (SUZUKI SUPER GREASE "A")

Clutch Release Shaft Fork
Apply grease to end of fork.

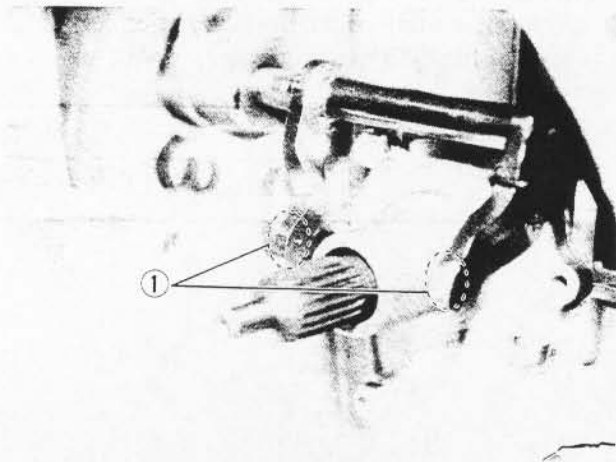

Fig. 11-16 ① Grease (SUZUKI SUPER GREASE "A")

Clutch Release Arm

Align two punch marks when installing clutch release arm on clutch release shaft.

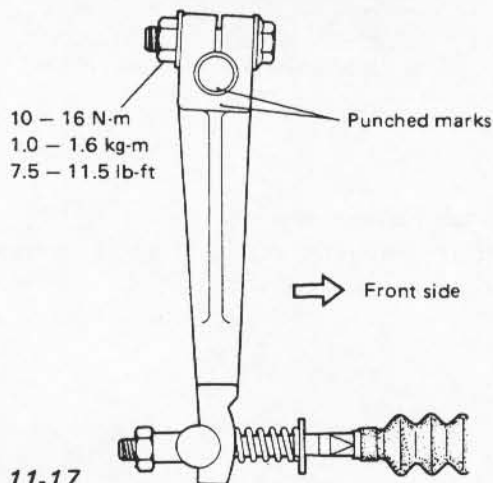

Fig. 11-17

Clutch Release Shaft Bushes

For reinstallation of bushes, refer to p. 13-5 in SECTION 13 TRANSMISSION of this manual.

Transmission

For remounting transmission, refer to p. 13-4 in SECTION 13 TRANSMISSION of this manual and reverse dismounting procedure.

Before remounting transmission ass'y, apply grease (SUZUKI SUPER GREASE I) to input shaft. Refer to Fig. 13-84.

11-5. MAINTENANCE SERVICES

Clutch Pedal Height

Adjust height of clutch pedal with clutch pedal stop bolt so that pedal is level with brake pedal. Tighten lock nut after adjusting.

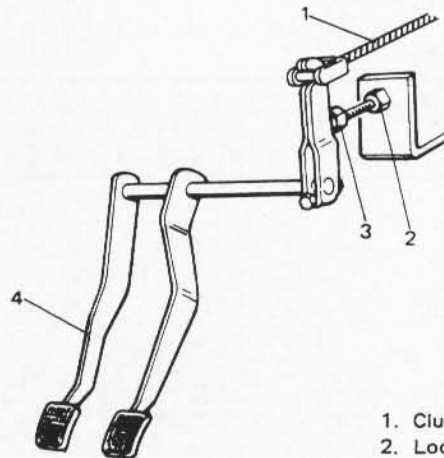

Fig. 11-18

- 1. Clutch cable
- 2. Lock nut
- 3. Adjust bolt
- 4. Clutch pedal

Clutch Pedal Free Travel

1) Depress clutch pedal, stop the moment clutch resistance is felt, and measure distance (clutch pedal free travel). Free travel should be within the following specification.

Clutch pedal free travel	20 - 30 mm (0.8 - 1.1 in.)
--------------------------	-------------------------------

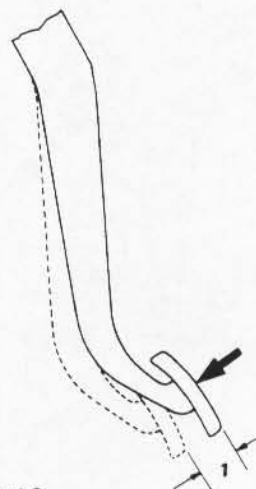

Fig. 11-19

- 1. Clutch pedal free travel

2) If free travel is out of specification, adjust it with clutch cable outer nuts.

NOTE:

After adjusting free travel, make sure that the clutch cable end protrudes at least 5 mm from joint nut.

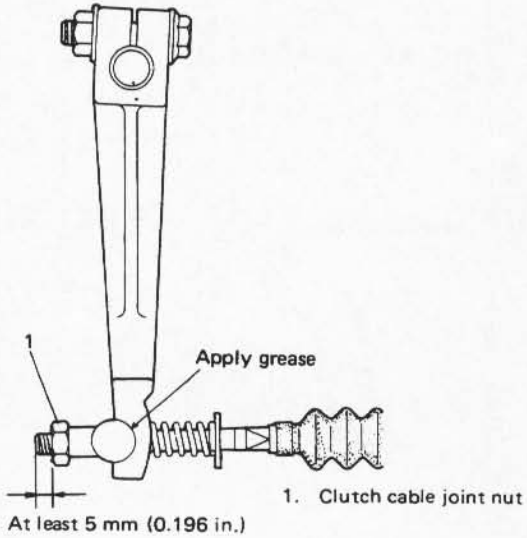

Fig. 11-20

Clutch Cable Lubrication

Apply grease to hook part ① of clutch cable.

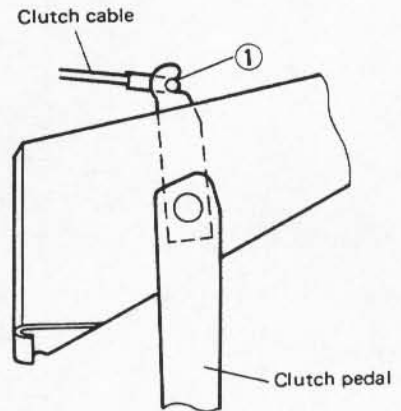

Fig. 11-21

Clutch Cable Routing

1) For left-hand side steering vehicle.

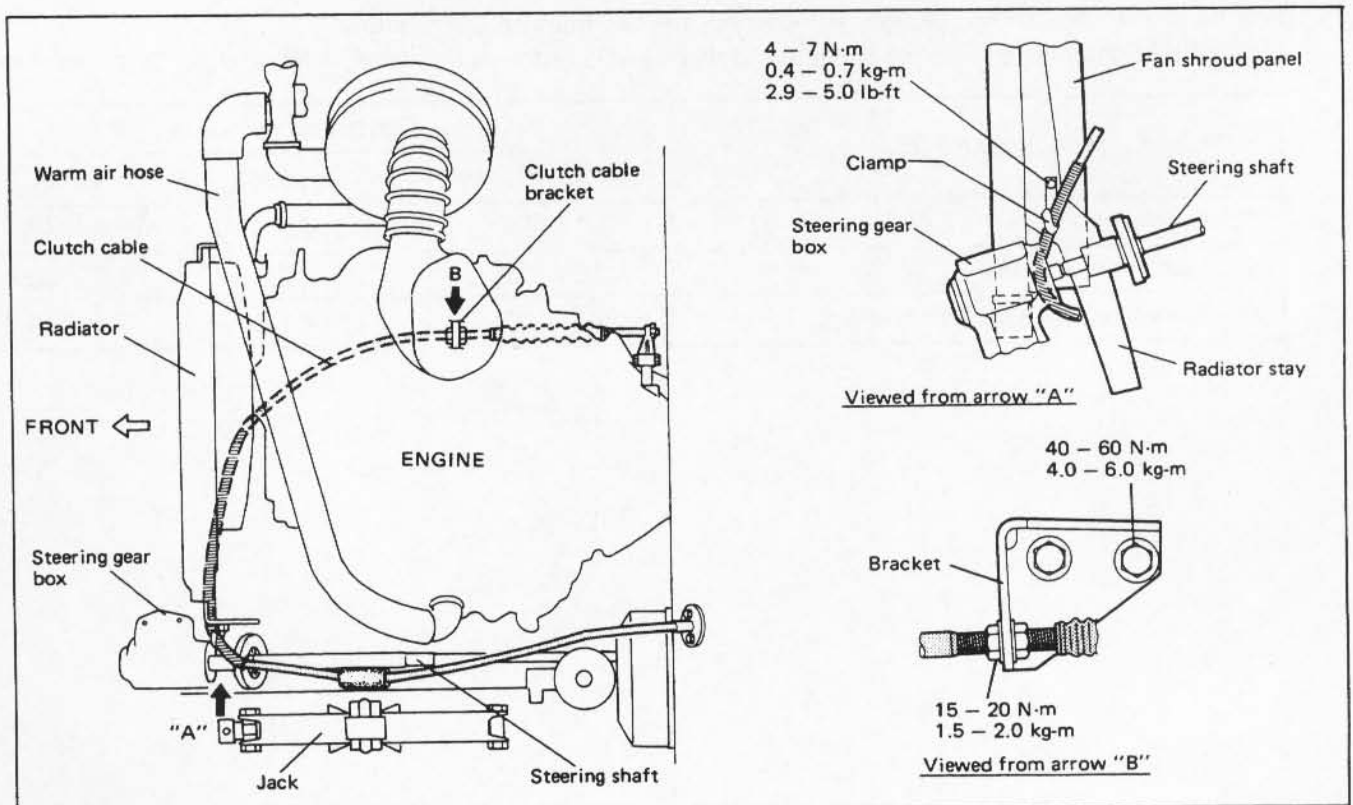

Fig. 11-22

2) For right-hand side steering vehicle.

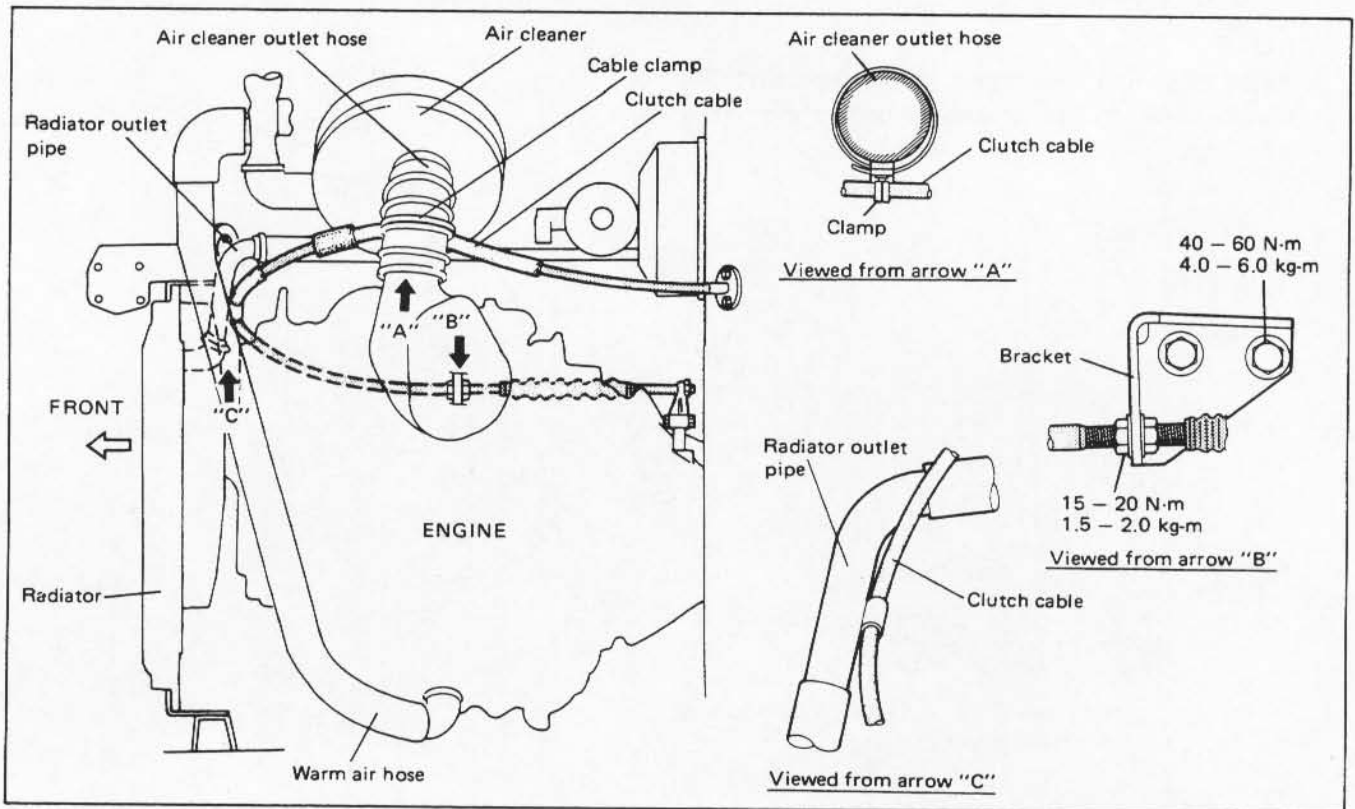

Fig. 11-23

11-6. RECOMMENDED TORQUE SPECIFICATION

Be sure to torque each nut or bolt, if loosened, to specification given below.

If specified tightening torque for particular bolt or nut is not included here, refer to p. 0-12 of this manual.

Fastening Parts	Tightening torque		
	N·m	kg·m	lb·ft
1. Flywheel bolts	57 – 65	5.7 – 6.5	41.5 – 47.0
2. Clutch cover bolts	18 – 28	1.8 – 2.8	13.5 – 20.0
3. Clutch release arm bolt and nut	10 – 16	1.0 – 1.6	7.5 – 11.5