

2.15. Checking suspension and steering control

BACKGROUND

See Fig. [Details front suspension cars FJ60, 62](#), fig. [Front suspension FJ80 cars](#).

Checking

ORDER OF PERFORMING

1. Set-wheel drive in the provision of direct, block the wheels. Turn the steering wheel right and left. If there is a significant movement, the reason is the wear of bearings hub ([see 2.39](#)), steering column shaft, intermediate shaft, ball pillars levers suspension ball joints or steering mechanism, or incorrect adjustment or worn steering mechanism.

2. work at the abnormal wear and parts management steering and suspension point reinforced swinging the body while driving on bumpy road, skidding with a turn, grabbing the steering wheel.

3. out the shock absorbers, which several times dramatically click on each corner of the car and release. If, after one or two clicks car body is not returned to the original position, it indicates a failure of legs suspension and the need for their replacement. If you press and release the car listen to the sounds, which publishes details of the suspension.

Checking the bottom of the car

4. Lift the car and set on the footprint.

5. check tread pattern and tyre pressure.

6. Check the pivot shaft between the steering column and steering crankcase.

7. Availability Check Steering gear casing podtekany oil or seepage through the pads. Make sure the seal integrity and protective covers, in the reliability of mounting clamps protective covers.

8. check the reliability of fastening parts steering, the lack of them mechanical damage. Look for the loose ball joints steering slats.



9. check all threaded connections delays, the availability otsoedinivshihnya or broken parts, the state of the seals (arrow shown in the photo on the left) and rubber suspension bushings (right photo).

10. Have Assistant povraschat steering wheel, watch with a turn of the steering wheel is for play in the details steering, flexure details of their freedom of movement (lyuftami). If we find significant connections backlashes in steering control oslabshee find the connection.



11. check wheel bearings, rotating wheel and pokachivaya recessed for the top and bottom surfaces. Notable play points to the need for disassembly and replacement hub lubrication.

12. turning Check the hub bearings, which knot tire shake up and down. If found to play, then you should check the condition of the bearings and replace the hub lubrication.

13. Check Cardan joints, the availability of play, sliding sleeves vilchatoy slot in the shaft.

14. podtekany Look for the boat in the handout boxes and transmissions.

Lubrication Running Gear

ORDER OF PERFORMING

1. Grease runs through syringe oiler (on the vehicle openings under Oiler closed plugs, oiler vvorachivayutsya with lubricant).

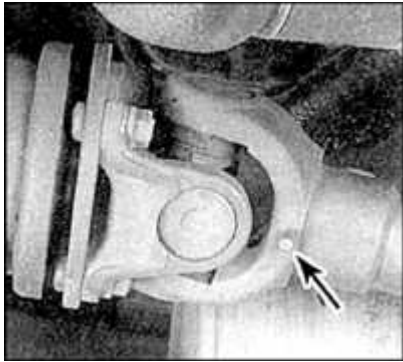

2. Smazku start turning to the node (the place specified lubrication arrow). Lubrication continue until it does not seem like a lubricant hub.



3. fork Then brush sliding spline coupling (place lubrication indicated arrow).

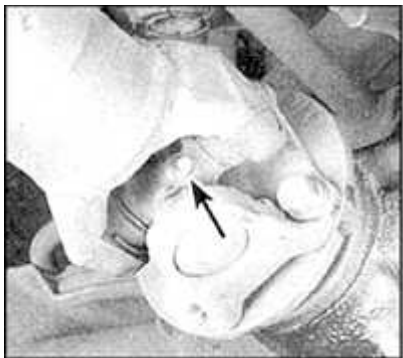

4. Smazhte cardan shaft hinge (place lubrication indicated arrow).



5. Smazhte turning rudder limiter (place lubrication indicated arrow).

6. Smazhte litolom latches and rack bonnet.
7. frying oil for the engine bonnet hinges and locks and doors.
8. Smazhte graphite or silicon spray lubricant drums switches locks and seals doorways.

2.2. Technical Specifications

BACKGROUND

Recommended viscosity oil to the engine in different temperature ranges

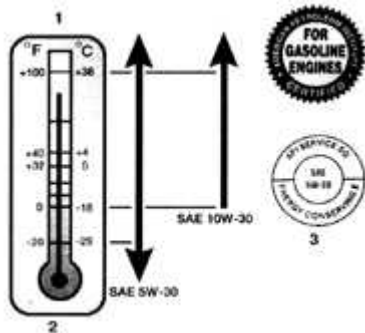

1. Hot climate
2. Cold Climate
3. If you buy pay attention to this label merchandise

Numbering cylinders and distributor in the direction of rotation of the engines 2F and E-3F

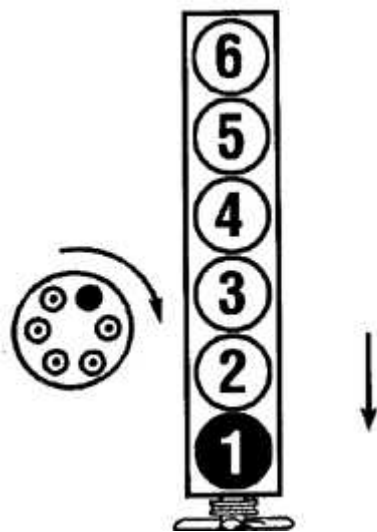

A dark circle marked the conclusion 1 - the first cylinder.

Numbering cylinders and distributor in the direction of rotation of the engines 1FZ-FE

A dark circle marked the conclusion 1 - the first cylinder.

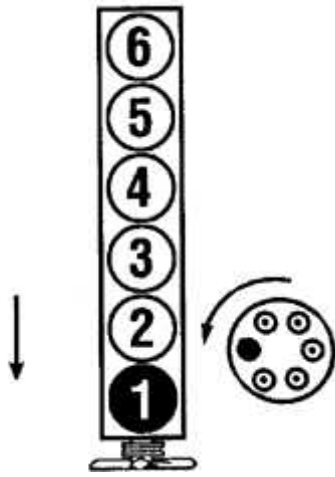

Recommended lubricants and fluids

Engine Oil	Motor oil or API SH SG
Viscosity	see Fig. Recommended viscosity oil to the engine in different temperature ranges
Cooling fluid	Antifreeze based on ethylene glycol
Brake fluid	DOT3
Liquid hydraulic clutch	DOT3
Fluid power steer	automatic transmission fluid Dextron II
Oil for mechanical CPR	Cylinder oil API GL-4, or GL-5 SAE 80W-90
Oil handout boxes	Cylinder oil API GL-4, or GL-5 SAE 80W-90
Oil for rear axle gear	Oil hypoid transmissions API GL-5 SAE 80W-90
Lubrication of general-purpose	Lithium grease NLGI No.2

Modus Operandi cylinders

Engines 2F and E-3F	1-5-3-6-2-4, the direction of rotation distributor ignition clockwise
- FE engine 1FZ	1-5-3-6-2-4, the direction of rotation distributor ignition clockwise

Gaps in the valve (mm):

Engines 2F (progrret):

-- inlet	0.20
-- Outlets	0.35
Engines E-3F (Cold):	
-- inlet	0.20
-- Outlets	0.35
Engines 1FZ-FE (Cold):	
-- inlet	0.15 - 0.25
-- Outlets	0.25 - 0.35
Pedal clutch	
Automotive brands FJ60 and FJ62:	
-- height above the fifth floor of body	181 mm
-- Free running	13 - 23 mm
The brakes (also see 8.1)	
Pedal brakes:	
-- DM FJ60 cars and FJ62:	
• height above the fifth floor of body	180 mm
• Free running	3 - 6 mm
-- DM FJ80 cars:	
• height above the fifth floor of body	167 mm
• Free running	3 - 6 mm
Progress hand brake lever:	
-- drum brakes	5 - 6 clickstream
-- disc brakes	5 - 6 clickstream
Suspension and steering	
Luft helm of the rim	40 mm
Luft ball suspension towers	0

Tightening moments, N.m.

Bolts pallet automatic transmission	6.1
Automatic transmission drain plug	25
Traffic jams handout boxes	33

Traffic jams gearboxes	44
Drain plug engine	25
Candles	25
Nuts wheels	110

2.33. Brake system

ORDER OF PERFORMING

1. Lift the car and remove the wheel.

Checking disc brakes

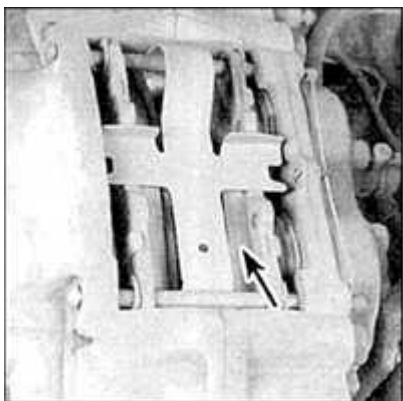

2. Pads can be verified through a window in supporte (pointed arrow).

3. Measure the thickness of the friction linings, and if the thickness is less than the specified in [subsection 8.1](#), then replace the pads.

4. If you have any doubts about the normal lining, the pad should be removed.

5. Заодно measure the thickness of the disk and check the condition of the surface (regardless of its thickness). If the thickness smaller than normal, the drive replaced. Minor defects are removed by grinding the surface, replace the badly worn disc.

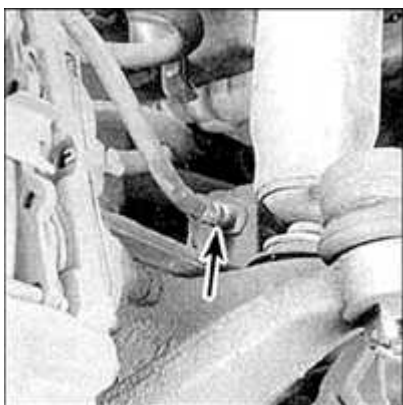

6. Check the hose (place checks indicated arrow) and hydraulic brake tubes. Make sure tightening compounds, the lack of contact with moving parts. All detected defects immediately se.

Checking drum brakes

7. Remove the drums ([see 8.6](#)).

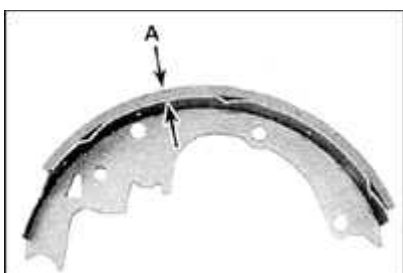

8. check the thickness of (A) the friction linings. If their thickness (or distance to the heads of rivets) less than 1.6 mm, or there are traces EZR or serious injury, the pads replaced.

9. Check the springs and the regulator clearance between shoes and drums.

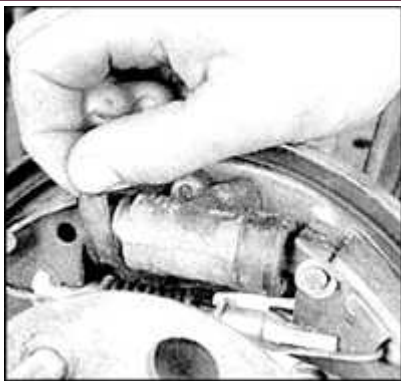

10. check podtekanie fluid from the wheel cylinder, bending dust cover. If we find a leak, replace the cylinder.

11. check the condition of drums. Minor defects zashlifuyte rind, if necessary protochite drums.

12. Set removed all the details and put the car. Wheel nuts tighten with a given moment.

2.4. Dates maintenance

BACKGROUND

Every 400 kilometers, or every week:

- checking the level of liquids;
- condition of the tyres and tyre pressure.

Every 4800 kilometres, or every 3 months:

- Maintenance of every 400 km;
- checking the liquid level in the automatic transmission;
- checking the liquid level in the hydraulic steering control;
- replacement in the engine oil and oil filter.

Every 12000 kilometres, or every 6 months:

- verification of the status and care of the battery;
- checking the cooling system;
- checking and replacing hoses in the engine compartment;
- inspection and replacement brushes windscreen cleaners;
- reshuffle wheels;
- verification of suspension and steering control;
- checking the exhaust system;
- checking oil level in the mechanical CPR;
- checking oil level readings in a Box;
- checking oil level in reducers bridges;
- condition of the seat belts.

Every 24000 km, or annually:

- servicing every 12000 km;
- check the thermostat air filter (on the carburetor engines);
- inspection and lubrication Exhaust valve;
- verification of petrol vapour recovery system;
- verification system recycling;
- checking the air valve carburetor;
- inspection and replacement zolotnik crankcase ventilation system;
- checking and replacing air filter;

- replacement of spark plugs;
- verification and adjustment of valves spacings;
- verification and adjustment of idle speed (in carburetor engines);
- verification, adjustment and replacement belt drive;
- check the fuel system;
- checking the brakes;
- verification and adjustment clutch pedals (brakes);
- replacement of the fuel filter.

Every 48000 kilometres, or every 2 years:

- servicing every 24000 km;
- inspection and replacement of high-voltage wires, distributor runner and lids;
- Installation and testing moment of ignition;
- caring for the cooling system;
- hubs and the front wheel bearings;
- replacement of automatic transmission fluid and filter;
- replacement of oil in mechanical CPR;
- replacement of oil in a Box handout;
- replacement of oil in the back (front) valve.

Every 96000 kilometres, or every 4 years, check and adjust the gaps in the valve to the engine 1FZ-FE.

Every 130000 km replace the oxygen sensor.

Warning

ⓘ If the vehicle was operated in difficult conditions (towing a trailer, frequent short trips, a ride on the dusty roads), the services specified in [sub-subsection 2.15](#) and [2.33](#), run through every 4800 km, or every 3 months.

In the long ride in an urban setting, with the air temperature above 27 ° C, in mountainous terrain with a trailer or transmission fluid change every 24000 km.

2.39. Hubs and the front wheel bearings

Checking and replacing lubrication

ORDER OF PERFORMING

1. front wheel bearings should be checked at each wheel swinging raise roll.
2. If we play with a vertical pokachivanii must dismantle hub and the status of the bearings.
3. Remove the wheel.
4. Remove support, otvedite aside and commit.
5. Remove the hub locking mechanism (see [sub-section 7.4.3.4](#)).

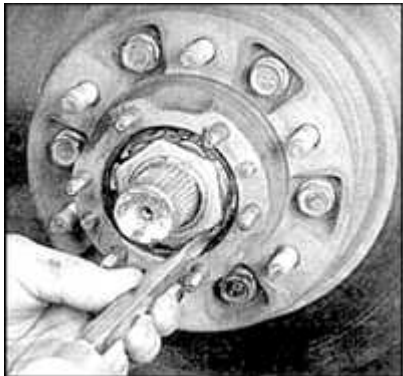

6. Raskontrite outer nuts and reject.

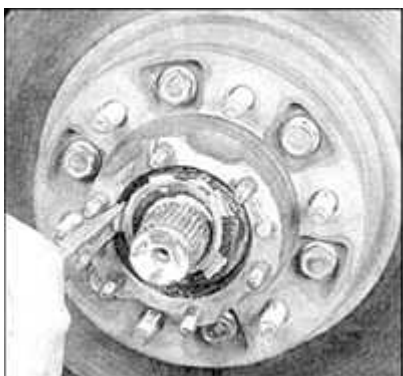

7. nimate C washer, reject the inner nut.



8. nimate C relentless washer.



9. Podayte a hub and back dostante outer bearing.

10. Remove the hub.

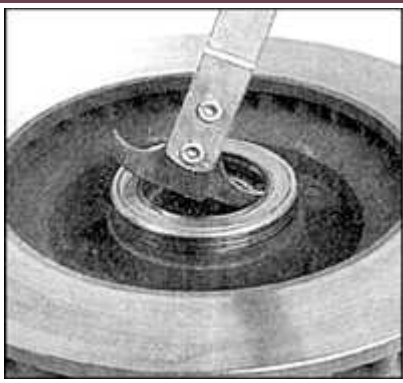

11. Obtain gland.

12. Remove the inner bearing.

13. Thoroughly rinse hub bearings, and the solvent and dry.

14. Inspect bearings and outdoor magazines. If we replace the bearing damage, which vybeyte magazines and brass borodkom zapressuyte new.



15. Zalozhite in tugoplavkuyu bearing lubrication.

16. Smazhte thin layer neck hub, the internal surface of magazines bearings, seals and mounted under the gland.

17. Zalozhite lubrication in the cavity between the outer hub magazines, creating a lubricant Swagelok finger on the edges of magazines.

18. Set in the inner bearing hub and obmazhte side of the bearing lubricant.



19. Zapressuyte gland flush with the surface of hubs.

Adjusting

ORDER OF PERFORMING

1. Set hub and the outer bearing.

2. Odente washer and nut inner wrap with no 51 Nm, while provorachivaya hub.

3. release and re-tighten the nut with 4.8 Nm moment while provorachivaya hub. Make sure there is no loose, and the wheel rotates freely.

4. Odente dog washer and nut to tighten the outer point 56 Nm Check loose, with a play perezatyanite inner nut. Fold kontrovochnye projections washers in opposite directions.

5. Furthermore assembly takes place in reverse order. Lightly brush litolom blocking hub node (excess lubrication is not permitted).

2.28. Replacing spark plugs

BACKGROUND

The set of tools to replace the spark plugs

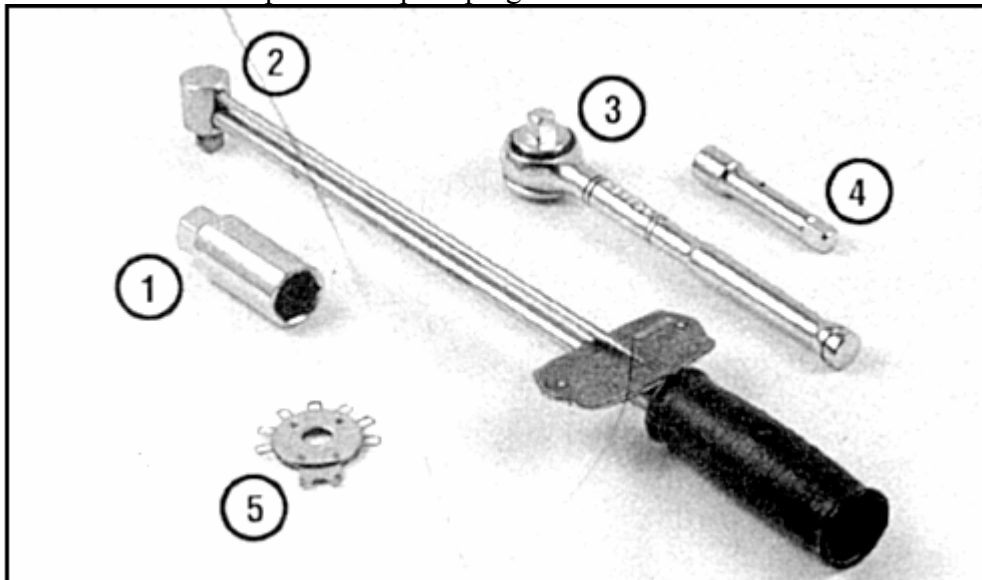

1. Key candle tortsovy
2. Dynamometer key
3. Clapper
4. Perechodnik
5. Set sizes to test gap between electrodes candles

Adjusting

ORDER OF PERFORMING

1. Prepare tools and accessories. When the candle must buy new candles the recommended type, and exhibit a gap walk instead of the old, replacing a candle each separately.
2. Check the new candles. If you notice any signs of damage Detention candle is not set.

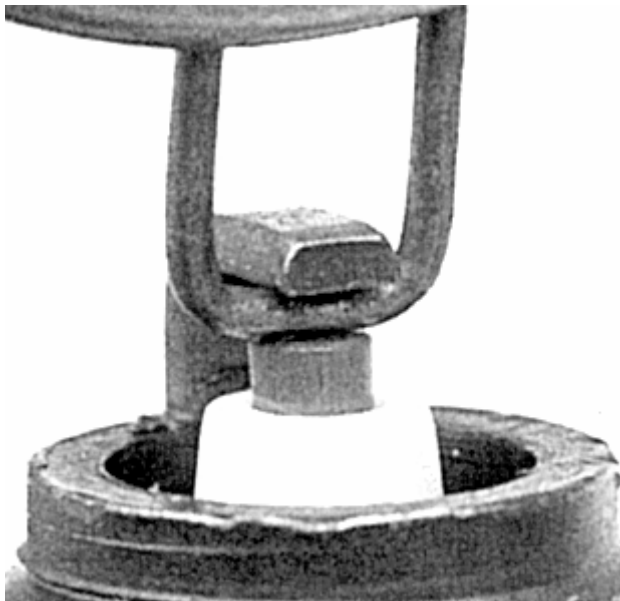

3. Check the gap between the electrodes new candles caliber Round section. The gap between the electrodes must the same as specified in podkapotnoy plate.

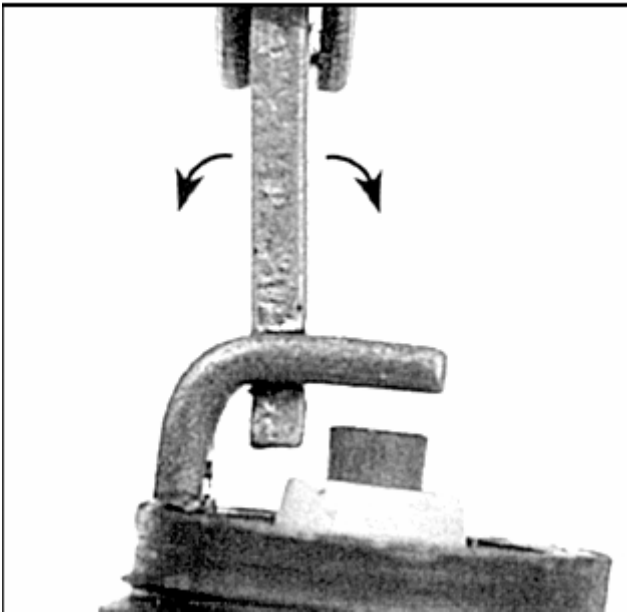

4. If there is a gap does not comply with rules, the electrode with podognite through swivel to set casing sizes.
 5. If the electrode is not the same side with the central, the podognite lever on the main body set up to calibre combining the two electrodes on the center candle.
- Withdrawal

ORDER OF PERFORMING

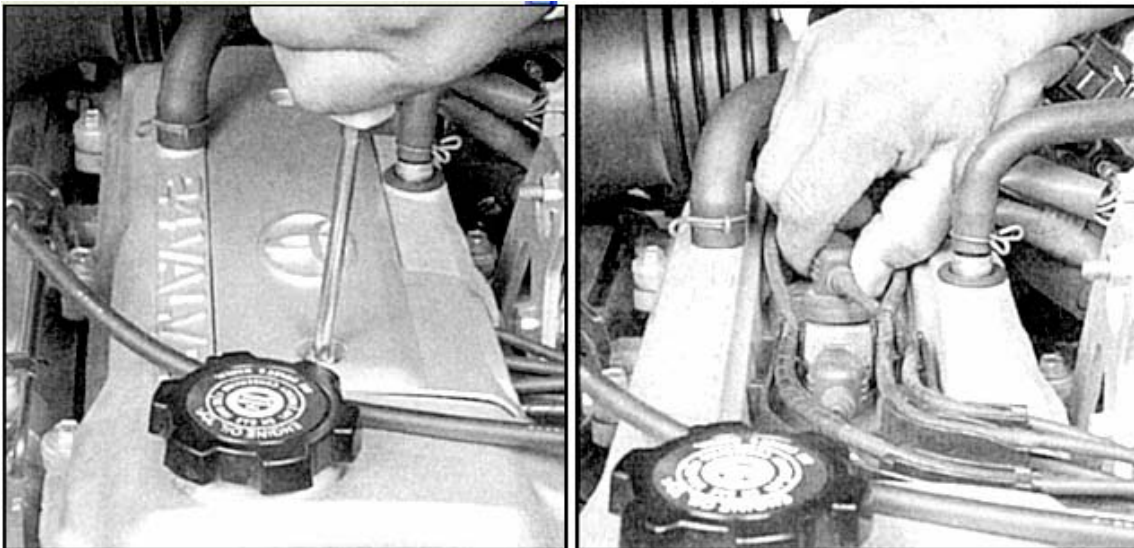

1. At 1FZ-FE engine to access un-candles lining (left). Turn on the floor tip-trafficking, at the same time attaching the upward force and dostante wire (right photo).

2. Purge pump locations around candles, removing dirt.

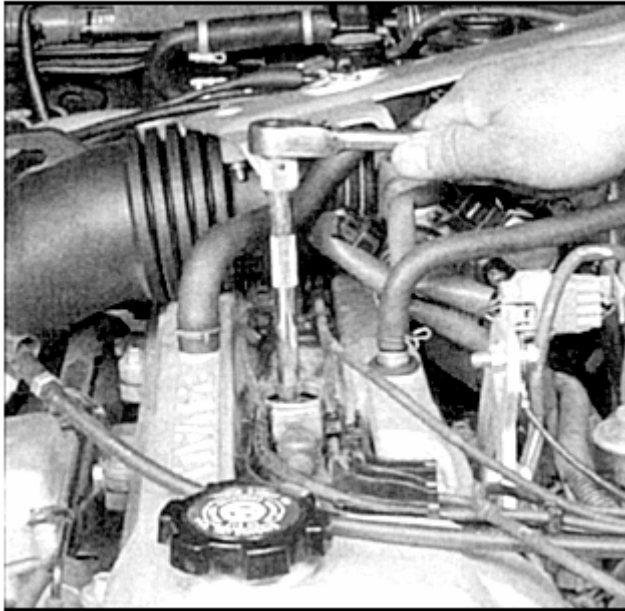

3. Remove the key to the candle power strip.

4. Regardless of whether a candle to change, or zavorachivatsya old, check the status of a candle.

Installation

ORDER OF PERFORMING

1. Before zavorachivaniem candles at the scene recommended Grease threads against prihvata composition.

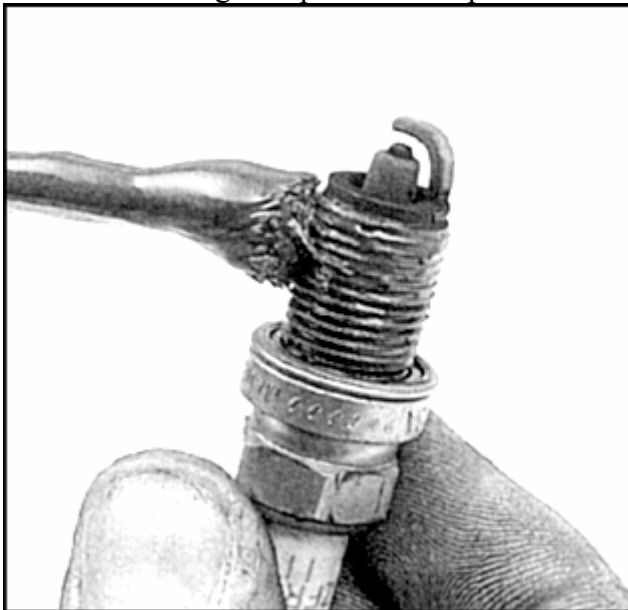

2. To wrap a candle without distortions dressed in a candle stretch hose with an internal diameter of 9.5 mm. Once Candle will zavorachivatsya with twisting, hose begins scroll to the detention facility, which prevents damage threads.

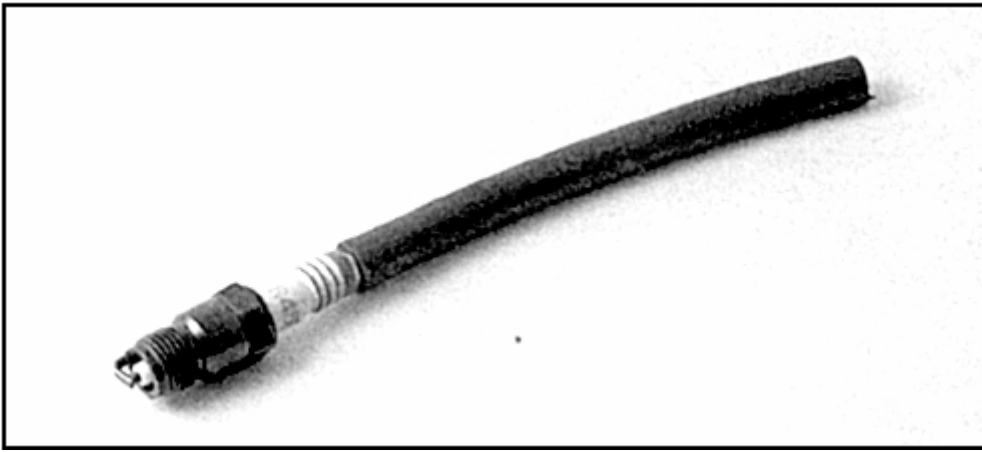

3. Tighten candle with a given moment.
4. Set tip, turning to the sex-trafficking and simultaneously annexing sent down effort.
5. In a similar manner to replace the remaining candles.

2.44. Gaps in the valve to the engine 1FZ-FE Check and adjust

The checks and adjusts spacings in an engine valve 1FZ-FE spend every 96000 km, or every 4 year.

Warning

Valves at the regulated engine selection washers thickness, so will need special otzhatiya push for the device.

1. Disconnect the battery from the masses.
2. Remove the spark plugs (see 2.28), remove the cover and set the cylinder heads piston 1 - the first in the cylinder TDC sensitivity compression.

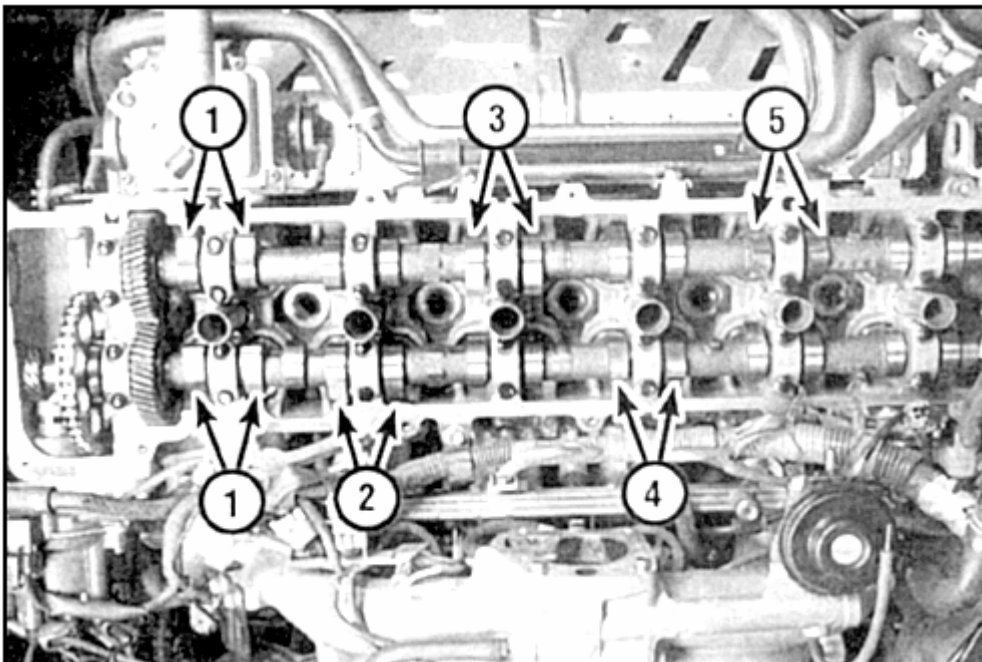

3. Measure the space between kulachkom raspredvala and push in these valves, recording each result.

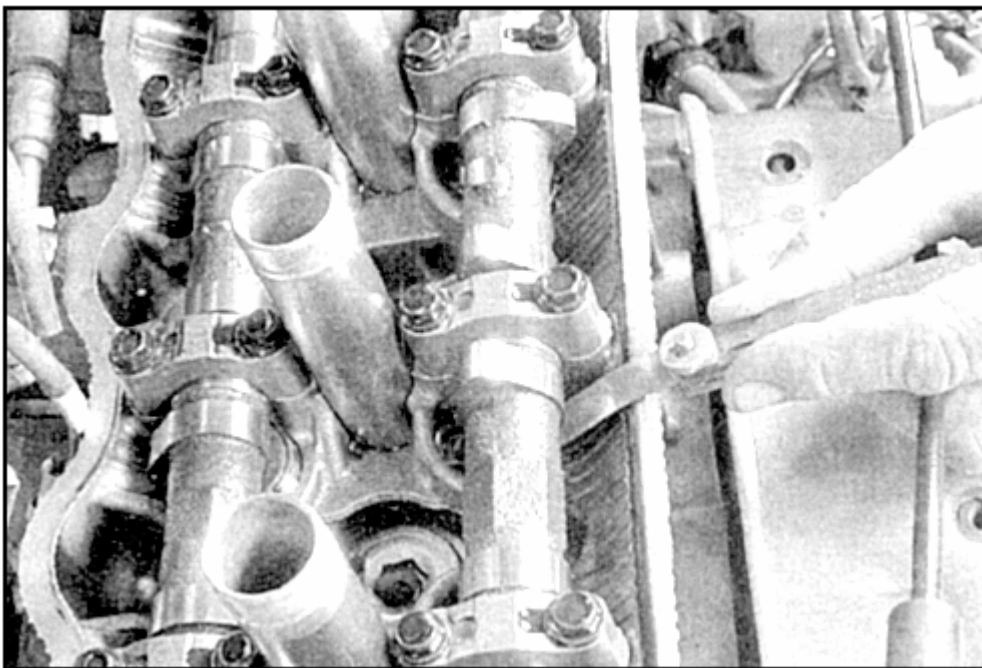

4. When checking the thickness of this gap probe should take place with little effort.

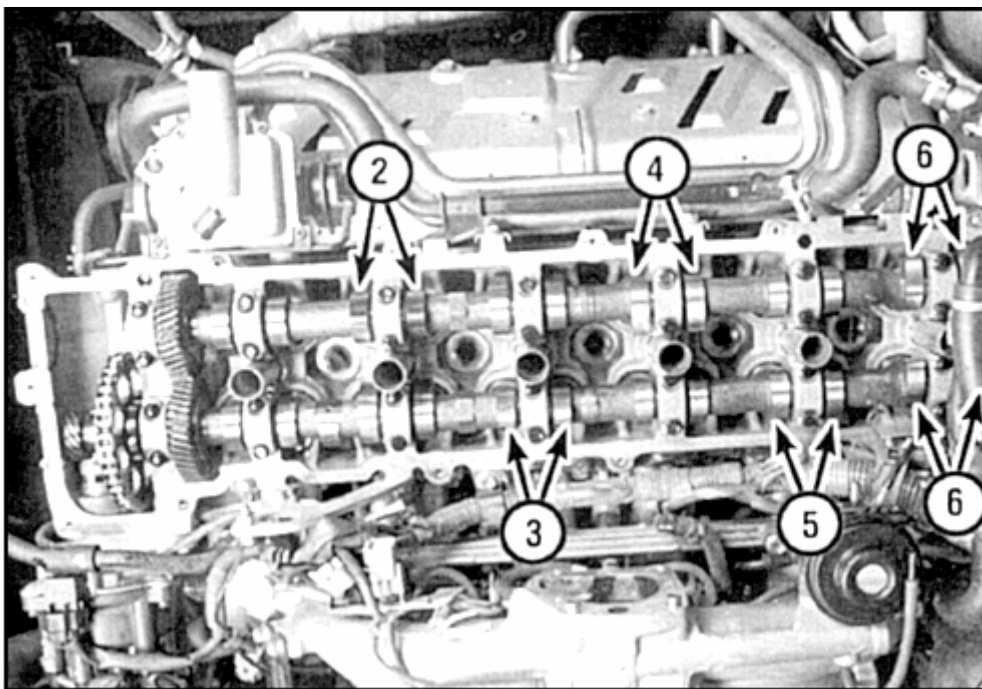

5. Turn on the crankshaft 1 turnover on the bar TDC
1 compression - m cylinder and measure the gap in the valve identified
for illustration.

6. Measuring ranges, provernite crankshaft so that tougher raspredvala first adjustable
valve was
up.

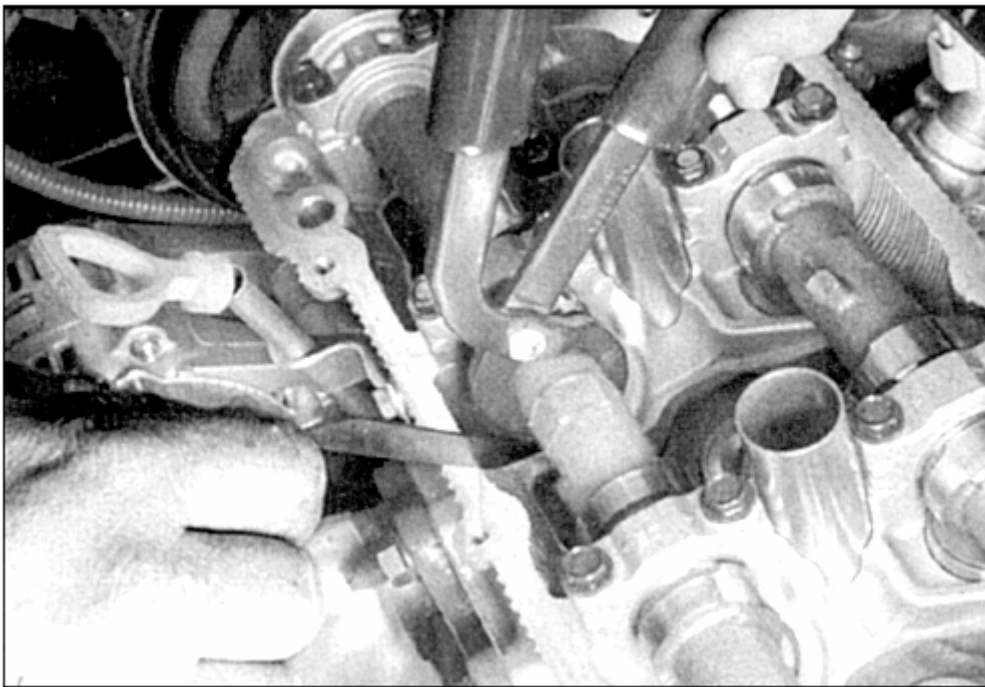

7. Push and squeeze dostante adjusting washer. For install a device so that the long jaw mites devices seized by the lower tide pusher, a short upiralas in the very top edge stacker. Squeeze the mites, little emphasis prosunte device (or natsepite hook to handle mites) fix pusher.

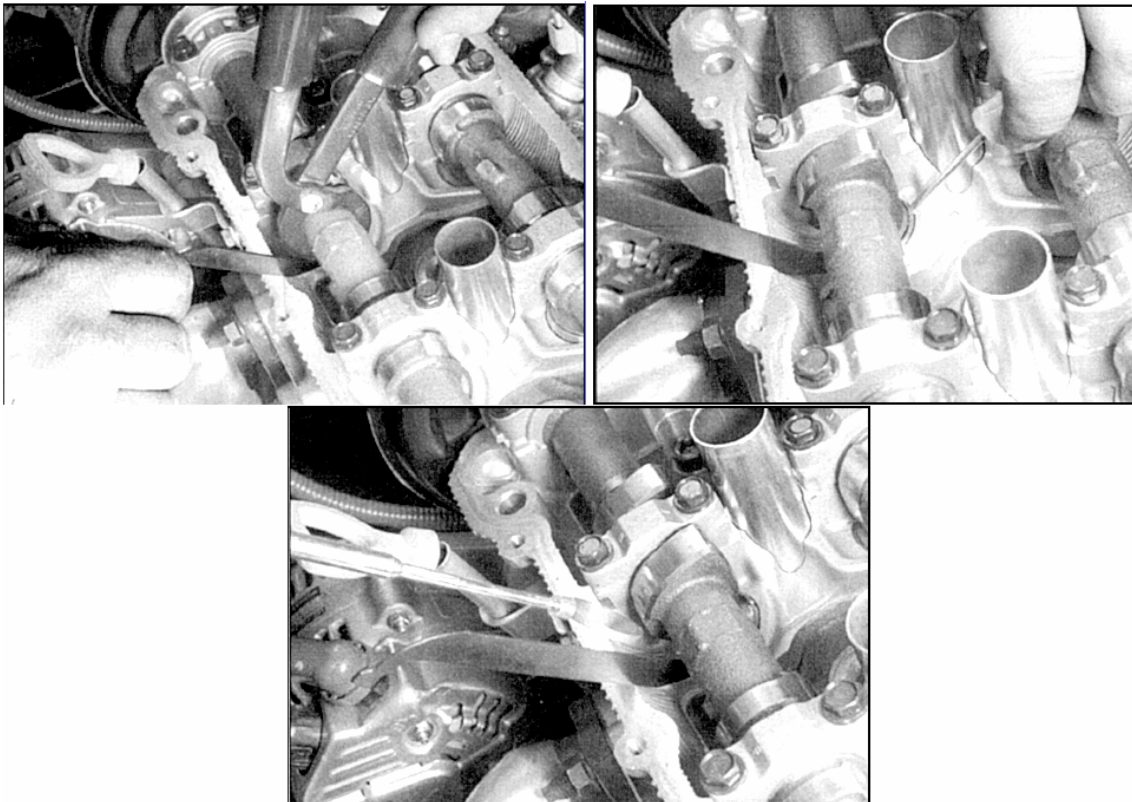

8. Remove ticks. Hold pusher, dostante adjusting washer screwdriver (left), or magnetic tweezers (right photo).

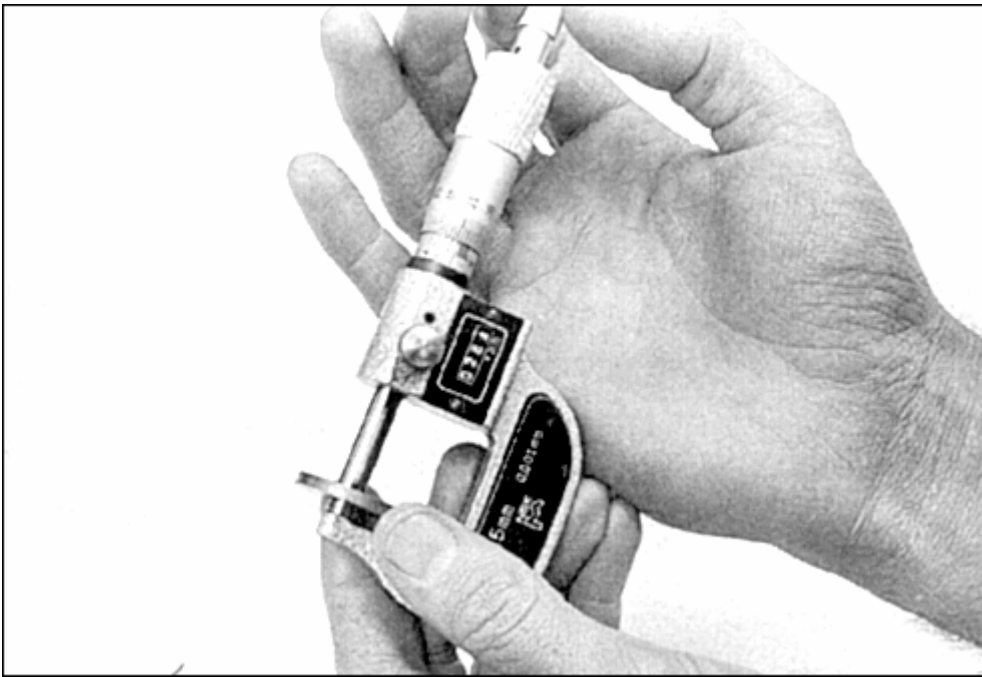

9. Measure the precise thickness control withdrawn washers.

10. Determine the thickness of remote-laying, in which a gap in the relief valve will be consistent with the

A normative:

$$N = T + (A - V)$$

T - thickness withdrawn adjusting washers,

A - measured gap

N - adjusting the thickness of the new washers,

V - the required clearance (see 2.2).

11. Producer of spare parts supplied tuning size washers 17 teams. Choose washer so that

thickness control washers were installed as close as possible to design. You can also rearrange

suitable thickness washer, rented with the push of another valve, which requires clearance adjustment. This

reduces the number of purchased washers.

12. Squeeze pusher (see above), and installing a new washer control.

13. Repeat for the remaining washers to be replaced. Install all the details taken in reverse order.

Table size groups adjusting washers

1	2,500
2	2,550
3	2,600
4	2,650
5	2,700
6	2,750
7	2,800
8	2,850

9	2,900
10	2,950
11	3,000
12	3,050
13	3,100
14	3,150
15	3,200
16	3,250
17	3,300

3.1.1. Technical Specifications

BACKGROUND

Numerical order cylinders and the direction of rotation and distributor of engines 2F E-3F

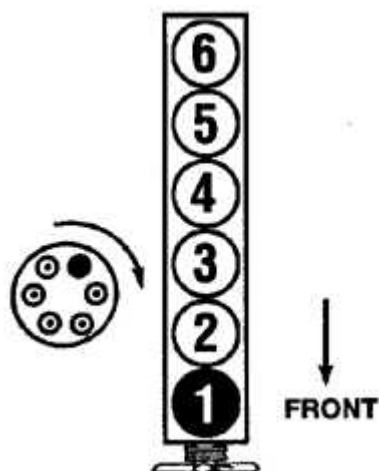

A dark circle marked by the withdrawal of 1 - the first distributor ignition cylinder.

Engine 2F

Displacement	4.2 l
Numbering cylinders	1-2-3-4-5-6
Modus Operandi	1-5-3-6-2-4
Raspredval (sizes and spacings in mm)	
Diameter strongholds necks	
-- 1 - and	47.955 - 47.975
-- 2 - th	46.455 - 46.475
-- 3 - y	44.955 - 44.975

-- 4 - and	43.455 - 43.475
Gaps in the neck strongholds	
-- Standard	0.025 - 0.075
-- limit	0.1
-- ovalnost	not more than 0.15
Size cams	
Standard	
-- inlet valves	38.36 - 38.46
-- exhaust valves	38.25 - 38.35
Limit	
-- inlet valves	38.00
-- exhaust valves	37.90
Axial movement	
-- Standard	0.200 - 0.262
-- limit	0.3
The gap in gearing gear drive raspredvala	
-- Standard	0.05 - 0.13
-- limit	0.2

Tightening moments (in Nm)

Screw fastening washers raspredvala hard to block cylinders	10.8
Nut sheaves crankshaft	175
Bolts cylinder heads	110
Screw fixation leading to the crankshaft drive	78
Bolts collectors	39
Screw fastening flywheel to the crankshaft	73
Screw fastening oil pallet	14
Screw fastening oil pump	17
Bolts wheels	
-- M8	21

-- M10	30
-- Screw lid cylinder heads	7.8
Bolts front lid	
-- M10	20
-- M6	6

Engine E-3F

Displacement	4.0 l
Numbering cylinders	1-2-3-4-5-6
Modus Operandi	1-5-3-6-2-4
Raspredval (sizes and spacings in mm)	
Diameter strongholds necks	
-- 1 - and	47.955 - 47.975
-- 2 - th	46.455 - 46.475
-- 3 - y	44.955 - 44.975
-- 4 - and	43.455 - 43.475
Gaps in the neck strongholds	
-- Standard	0.025 - 0.075
-- limit	0.1
-- ovalnost	not more than 0.15
Size cams	
Standard	
-- inlet valves	38.36 - 38.46
-- exhaust valves	38.25 - 38.35
Limit	
-- inlet valves	38.00
-- exhaust valves	37.90
Axial movement	
-- Standard	0.200 - 0.290
-- limit	0.3
The gap in gearing gear drive raspredvala	

-- Standard	0.100 - 0.183
-- limit	0.25

Tightening moments (in Nm)

Screw fastening washers raspredvala hard to block cylinders	10.8
Nut sheaves crankshaft	310
Bolts cylinder heads	110
Bolts mounting bracket to the ball cylinders	27
Bolts suction mounting bracket to collector	27
Screw fixation leading to the crankshaft drive	76
Bolts collectors	
-- Bolt (A) turnkey 17	64
-- Bolt (B) turnkey 14	45
-- Nut (S) turnkey 14	49
Screw fastening flywheel to the crankshaft	76
Screw fastening oil pallet	8.4
Screw fastening oil pump	17
Bolts wheels	
-- Bolt turnkey 12	22
-- Bolt turnkey 14	30
Bolts front lid	
-- Bolt (A) turnkey 10	4.3
-- Bolt (C) turnkey 10	4.3
-- Bolt (B) turnkey 14	22

3.1.3. Installing piston 1 - the first in the cylinder TDC BACKGROUND

Warning

This implies that the works are carried out with proper installation distributor ignition (if a distributor).

If you need to restore the proper position distributor, then define stroke engine on the feeling of compression is 1 - m cylinder when twisted candles, after

What align the labels moment of ignition (see below).

To install the same for 2F engine, and E-3F twin verhneklapannyh 1FZ-FE.

ORDER OF PERFORMING

1. Installing piston 1 - the first in the cylinder compression TDC sensitivity required for the performance and setting up operations (adjustable valve, the installation of the moment ignition, etc.).
2. Translate the transmission selector is in the Park or Neutral (for automatic transmission), or in a neutral position (on the mechanical CPR). Obtain central high voltage wire distributor ignition and connect with weight.

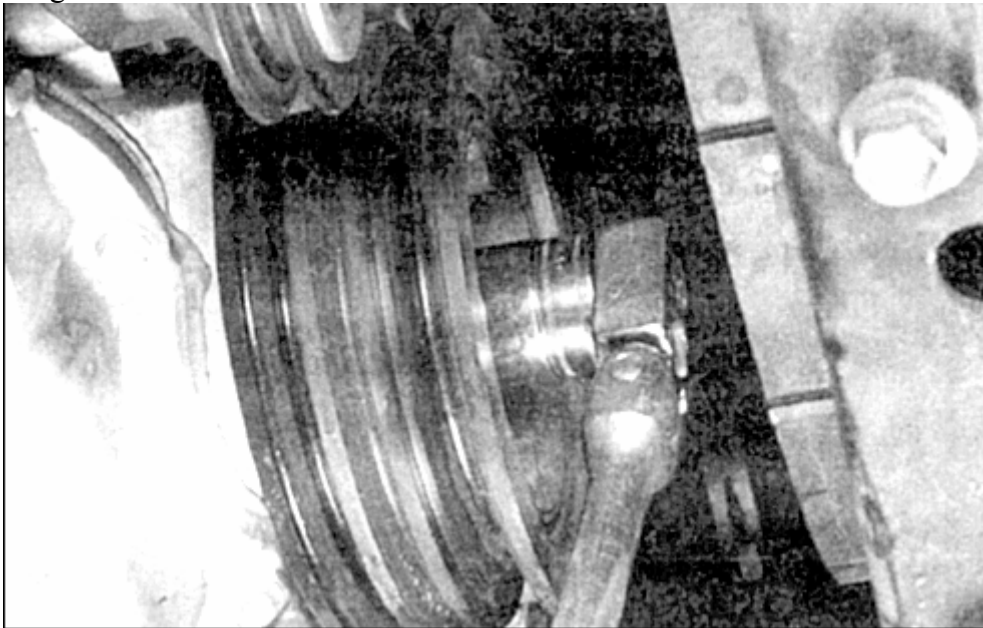

3. Provorachivaetsya key for the crankshaft sheaves head bolt clockwise.

4. According to the wires of candles 1 - go find the cylinder relevant conclusions on the lid distributor ignition and indicate risk on the case. Remove the lid distributor.

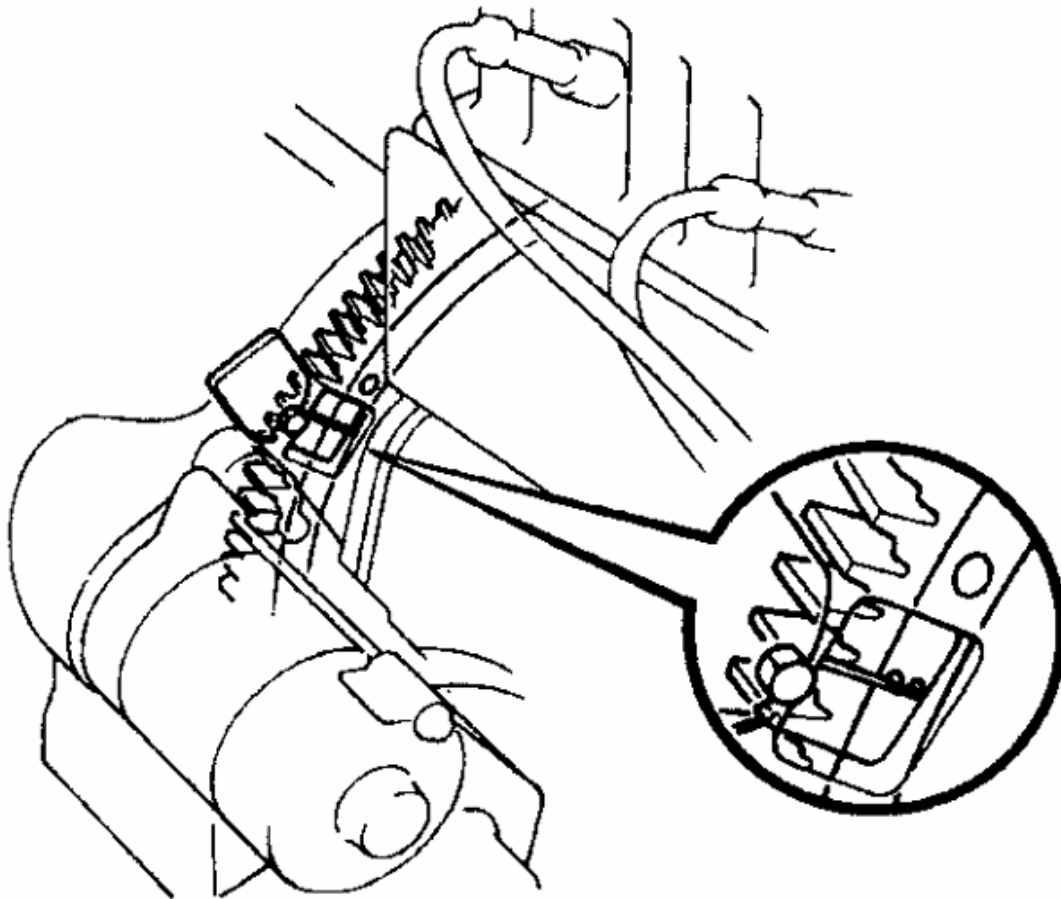
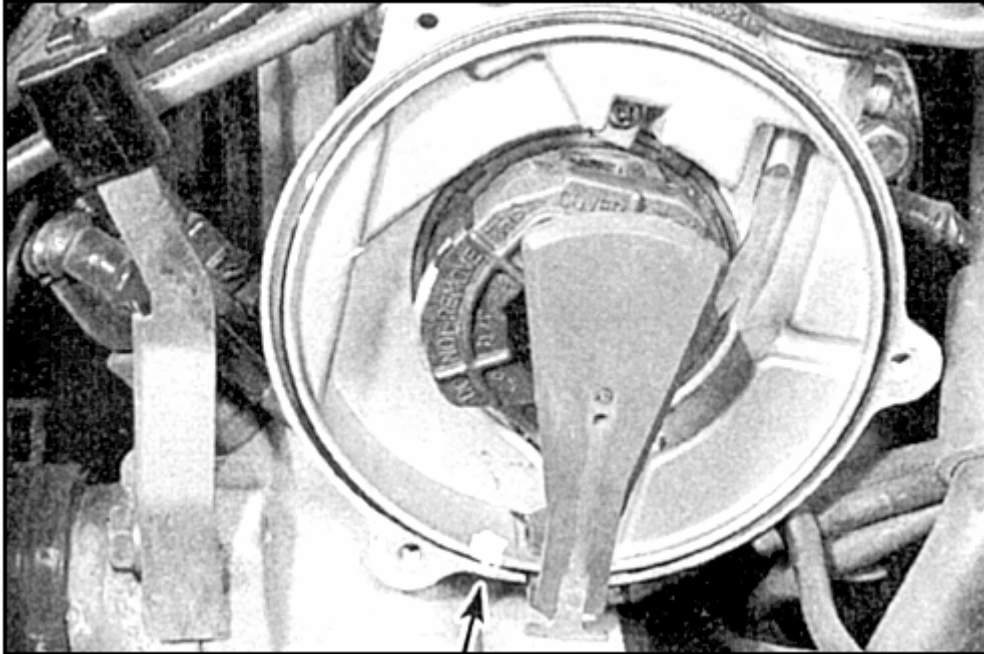

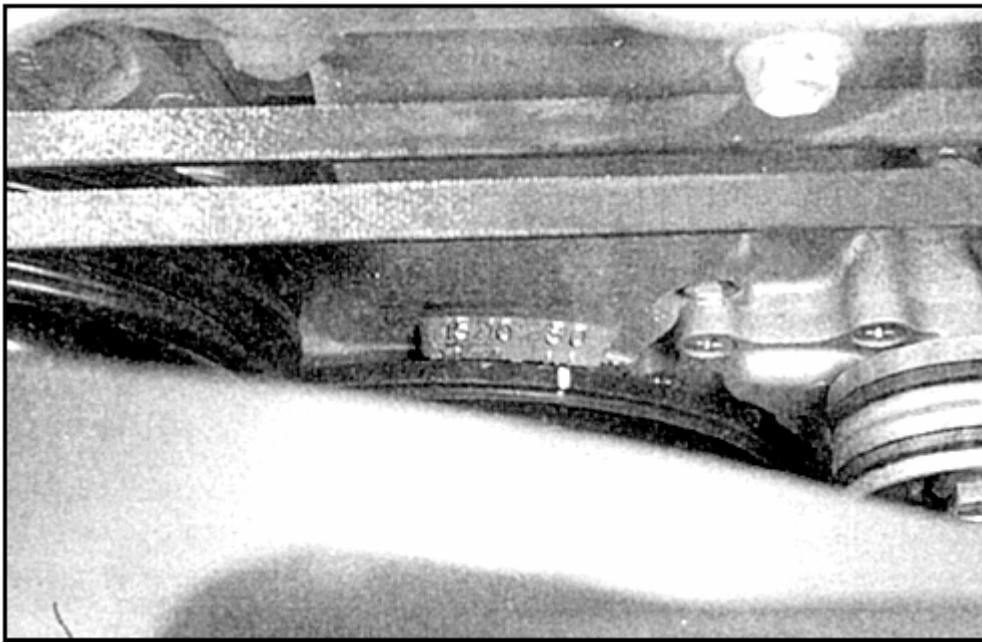

5. Provernite crankshaft key for head bolt sheaves clockwise until combining the risks to flywheel (leading disk manufacturer), with pointer (2F on engines and E-3F, left), or the cavity at the sheave crankshaft labeled "0" on the Fixed-scale (on engines 1FZ-FE, right photo).

6. If the bar is located opposite the distributor risks on the shell distributor, the piston 1 - On the cylinder is in tact TDC compression. If slider is at 180 ° of risks, the crankshaft provernite at 1 turnover, and then piston 1 - On the cylinder will compete in the TDC sensitivity compression. This marks on the scale sheave and should be combined, and a pointer must be located opposite the bar risks showing withdrawal 1 - the first cylinder.

Warning

If put piston 1 - On the cylinder is in the compression of such sensitivity TDC unable to read, the reasons are incorrect installation distributor Ignition, gear or chain drive raspredvala.

7. Indicate on the findings of other wires in the order of operation of the engine. We rotate the crankshaft further clockwise on the situation TDC 1 - th cylinder can be put in TDC piston of each cylinder by combining with slider Labeled conclusions.

3.2.1. Technical Specifications

BACKGROUND

Numerical order cylinders and the direction of rotation distributor FE engine FZ-1

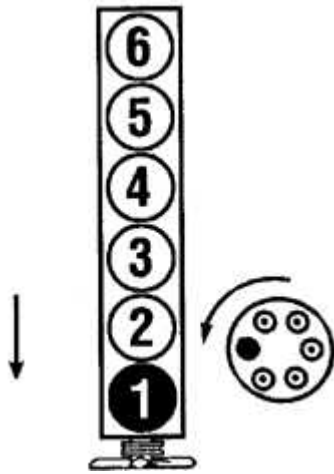

A dark circle marked by the withdrawal of 1 - the first distributor ignition cylinder.

Displacement	4.5 l
Numbering cylinders	1-2-3-4-5-6
Modus Operandi	1-5-3-6-2-4
Raspredval (sizes and spacings mm):	
Diameter strongholds necks	26.959 - 26.975
Gaps in the neck strongholds:	
-- Standard	0.025 - 0.062
-- limit	0.1
Roundness	not more than 0.06
Size cams:	
-- Standard	50.61 - 50.71
-- limit	50.51
Axial movement:	
-- Standard	0.030 - 0.080
-- limit	0.10
The gap in gearing gears raspredvalov:	
-- Standard	0.020 - 0.200
-- limit	0.30
The length of the valve springs in the free state	18.2 - 18.8

Oil pump:	
-- the gap between rotor and managed Corps	0.100 - 0,175 (limit 0,30)
• Standard	0.100 - 0.170
• limit	0.30
-- clearance in gearing rotors:	
• Standard	0.030 - 0.160
• limit	0.25
-- the gap between rotor and the lid:	
• Standard	0.030 - 0.090
• limit	0.150

Tightening moments (in Nm)

Bolts equalization chamber air intake	18
Bolts suction collector	18
Bolts exhaust manifold	36
Fixing the exhaust pipe to the exhaust manifold	57
Fixing thermal panel to the exhaust manifold	16
Fixing air tubes (PAIR-system):	
-- bolts	17
-- nuts	18
Bolt sheaves crankshaft	370
Bolts flywheel	75
Bolts leading disk	58
Bolt intake pipe heater	18
Bolts roller mortgage	33
Bolts cylinder heads:	
-- 1 - Step	36
-- 2 - Stage	dovernut at an angle of 90 °
-- 3 - Step	dovernut at an angle of 90 °
Screw fastening the front cover (raspredvalov chain) to the head of cylinders	18
Screw fastening lids strongholds necks raspredvala	15

Bolt led star raspredvala	68
Bolts oil pump	15
Nuts / fastening bolts maslopriemnika	17
Oil jets	17
Bolts pallet 1 (upper):	
-- screw with a head 14	39
-- screw with a head 12	17
-- 1 pallet fastening bolts to the front of the lid	17
Bolts pallet 2 (lower):	
-- bolt	6.9
-- Nut	7.8
Bolts oil level sensor	4.8
Expansion valve	44
Bolts holder rear gland	18
Nuts and bolts front lid	18
Nuts mortgage chains	18

3.3.1. Technical Specifications

BACKGROUND

ENGINE 2F and E-3F

(data for engines 3F-E are indicated in parentheses)

Compression:	
-- c standard	9.8 kgf / cm ² (9,8)
-- greatest difference compression in the cylinders	2.0 kgf / cm ² (2,0)
Oil pressure:	
-- idling (600 rpm)	not less than 0.28 kgf / cm ² (0,28)
-- 1600 rpm	2.4 - 4.9 kgf / cm ² (2.4 - 4,9)
Cylinder Block:	
-- internal diameter of the cylinder standard	94.000 - 94.05 (94.000 - 94,03)
-- tgear and ovalnost	no more than 0,02 (0,025)

-- maximum deformation of the plane razemnoy	0,15 (0,15)
The head of cylinders and valves:	
Permissible limits plane deformation razemnoy	0,15 (0,15)
The width belt valve head (the limit):	
-- intake	0,80 (1,0)
-- exhaust	1,0 (1,2)
The diameter of the rod:	
-- inlet valves	7.970 - 7.985 (7.970 - 7,985)
-- Outlets	7.960 - 7.975 (7.960 - 7,975)
The gap between the rod guide and valve bushing	
Standard:	
-- inlet	0.030 - 0.060 (0.025 - 0,060)
-- Outlets	0.040 - 0.070 (0.035 - 0,070)
Limit:	
-- inlet	0,10 (0,10)
-- Outlets	0,10 (0,12)
The length of the valve springs:	
-- in the free state	51,5 (51,5)
-- set	43.0 (43,0)
Crankshaft and connecting rods	
Pauk neck:	
-- Diameter	53.98 - 54.00 (52.988 - 53,000)
-- a gap in the rod bearings	0.02 - 0.06 (0.02 - 0,05)
Axial movement of connecting rods:	
-- Standard	0.11 - 0.23 (0.16 - 0,30)
-- limit	0,30 (0,40)
Indigenous Neck	
Diameter:	
-- N 1	66.972 - 66.996 (66.972 - 66,996)
-- N 2	68.472 - 68.496 (68.472 - 68,496)

-- N 3	69.972 - 69.996 (69.972 - 69,996)
-- N 4	71.472 - 71.496 (71.472 - 71,496)
The gap in the rod bearings	0.020 - 0.044 (0.020 - 0,044)
Luft crankshaft axis:	
-- Standard	0.06 - 0.16 (0.015 - 0,204)
-- limit	0,30 (0,30)
Roundness and tgear	not more than 0.1
Pistons and the ring:	
-- piston diameter (standard)	93.97 - 94.02 (93.96 - 93,99)
-- the gap between the piston and cylinder	0.03 - 0.05 (0.027 - 0,047)
The gap at the junction of piston rings:	
-- upper Compression	0.20 - 0.38 (0.20 - 0,42)
-- lower Compression	0.20 - 0.38 (0.50 - 0,72)
-- in maslosemnom (only for the engine E-3F)	0.200 - 0.820
The gap between the ring and the piston groove in:	
-- upper Compression	0.03 - 0.06 (0.03 - 0,07)
-- lower Compression	0.02 - 0.06 (0.05 - 0,09)

* All sizes and ranges are shown in mm.

Tightening moments (Nm) *

Nuts cap rod bearings	67 (52)
For engines 2F	
Screw cap indigenous bearings:	
-- N 1, 2, 3	130
-- N 4	114
For engines E-3F:	
-- with a head bolts 19	121
-- with a head bolts 17	103

* See also subsection 3.1.1.

Compression:	
-- Standard	11.2 kgf / cm ²
-- greatest difference compression in the cylinders	2.0 kgf / cm ²
Oil pressure:	
-- idling (600 rpm)	not less than 0.28 kgf / cm ²
-- 1600 rpm	2.4 - 4.9 kgf / cm ²
Cylinder Block:	
-- internal diameter of the cylinder (standard)	100.000 - 100.010
-- tgear and ovalnost	not more than 0.025
-- maximum deformation of the plane razemnoy	0.15
The head of cylinders and valves	
Permissible limits plane deformation razemnoy	0.15
The width belt valve head (the limit):	
-- intake	1.0
-- exhaust	1.0
The diameter of the rod:	
-- inlet valves	6.970 - 6.985
-- Outlets	6.965 - 6.980
The gap between the rod guide and valve bushing:	
-- Standard:	
• inlet	0.025 - 0.060
• Outlets	0.030 - 0.065
-- limit:	
• inlet	0.08
• Outlets	0.10
The length of the valve springs:	
-- in the free state	43.94 - 45.06
-- set	38.5
Crankshaft and connecting rods	
Pauk neck:	

-- Diameter	56.982 - 57.000
-- a gap in the rod bearings	0.032 - 0.050
Axial movement of connecting rods:	
-- Standard	0.160 - 0.262
-- limit	0.362
Indigenous neck:	
-- Diameter	68.982 - 69.000
-- a gap in bearings	0.042 - 0.060
Luft crankshaft axis:	
-- Standard	0.020 - 0.22
-- limit	0.30
Roundness and tgear	not more than 0.02
Pistons and the ring	
The diameter of the piston (standard):	
-- Group 1	99.950 - 99.960
-- Group 2	99.960 - 99.970
-- Group 3	99.970 - 99.980
The gap between the piston and cylinder	0.04 - 0.06
The gap at the junction of piston rings:	
-- upper Compression	0.30 - 0.52
-- lower Compression	0.45 - 0.67
-- in maslosemnom	0.15 - 0.52
The gap between the ring and the piston groove in:	
-- upper Compression	0.04 - 0.08
-- lower Compression	0.03 - 0.07

Tightening moments (Nm) *

Oil jets	22
Screw cap indigenous bearings:	
-- 1 - Step	66
-- 2 - Stage	dovernut at an angle of 90 °

Nuts cap rod bearings:	
-- 1 - Step	43
-- 2 - Stage	dovernut at an angle of 90 °

3.2. Verhneklapanny 1FZ-FE engine BACKGROUND

This subsection describes the types of repairs 6 - cylinder odnoryadnogo 1FZ-FE engine without disassembly of the car.

The engine mounted on vehicles since 1993 twin-engine with a top location of the valves. Raspredvala Drive - from the chain. Each cylinder accounts to 2 inlet and outlet valve. Left raspredval (in the course of the car) manages inlet, and the right - exhaust valves.

All engines of this type are equipped with electronic fuel injection.

3.3.7. The order dismantling the engine BACKGROUND

Crank-crank mechanism and piston engines Group E-3F (a device similar to the engine 2F)

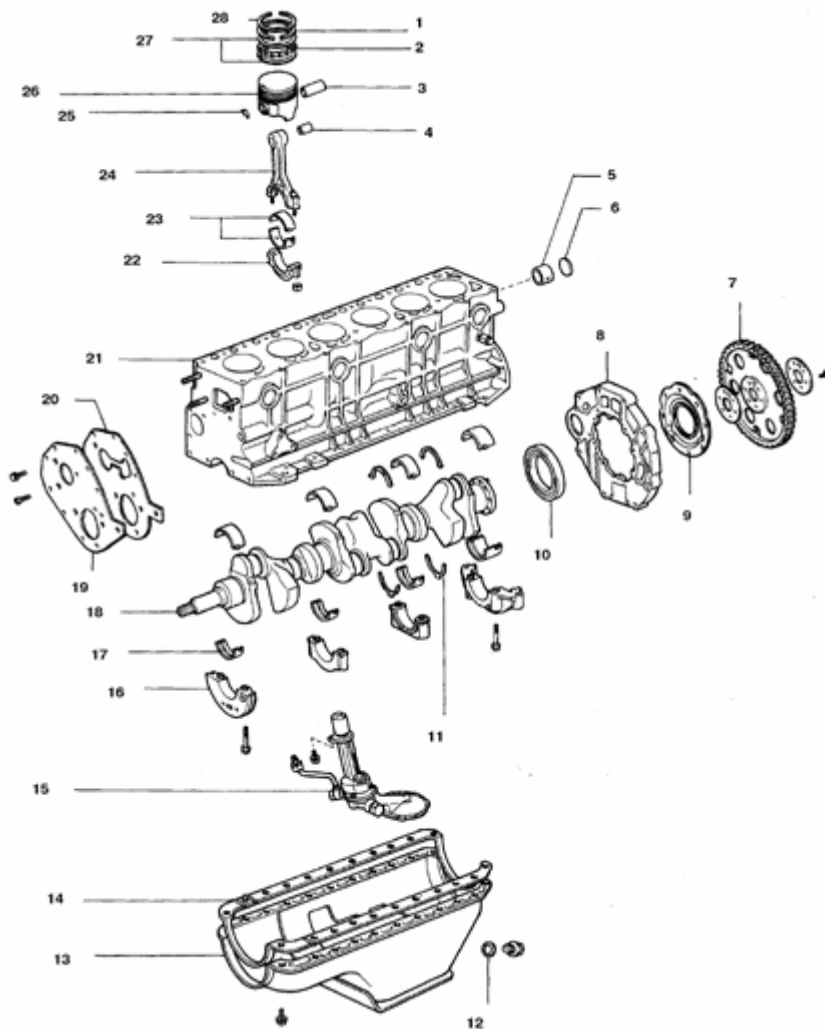

1. Ring Compression lower
2. Maslosemnoy expander ring
3. Smudge

4. Ferrule head shituna
5. Bearing raspredvala
6. Compensation caps
7. Leading disk
8. Connective Section crankcase
Transmission
9. Dust cap crankcase
Transmission
10. Salnick
11. Continued semirings
12. Gasket
13. Tray
- 14, 20. Gasket
15. Oil pump
16. Cover indigenous bearing
17. The liner indigenous bearing
18. Crankshaft
19. The front plate amplifier
21. Cylinder Block
22. Cover crank
23. Pauk liners
24. Shatun
25. Lock ring
26. Piston
27. Wheels maslosemnogo ring
28. Compression upper Ring

Crank-crank mechanism and a group Piston engines 1FZ-FE

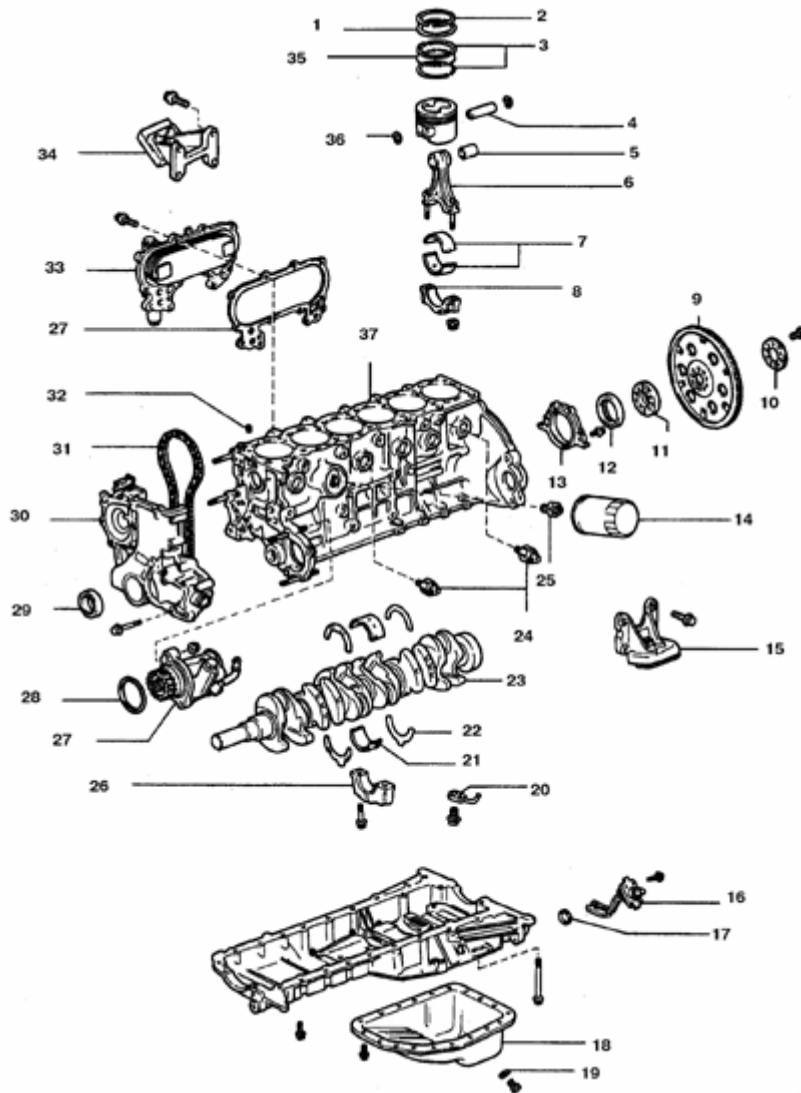

1. Ring Compression lower
2. Compression upper Ring
- Maslosemno expander ring
3. Wheels maslosemno ring
4. Smudge
5. Sleeves head crank
6. Shatun
7. Pauk liners
8. Cover crank
9. Leading disk
10. Rear control washers
11. The front control washer
12. Salnick
13. Holder
14. Oil filter
15. The left engine reliance
16. Oil level sensor
- 17, 19. Gasket
18. Tray 2
20. Check valve oil jets
21. The liner indigenous bearing
22. Continued semirings
23. Crankshaft
24. The sensor detonation
25. Connections

26. Cover indigenous bearing
27. The pump power
28. Sealing ring
29. Front gland
30. The front lid
31. The chain
32. Application
33. Masloohladitel
34. Right reliance
35. Maslosemnogo expander ring
36. Lock ring
37. Cylinder Block

ORDER OF PERFORMING

1. Recommended hear the engine at a special booth.
2. If not stand, it would seal the engine on a level site.
3. If acquired rebuilt engine, we have to remove all suspended aggregates, and then install them in exactly the same way as when Entrepreneurial overhaul. These aggregates are:

- generator and staves;
- parts of the system reduce the toxicity;
- distributor ignition, candles and the high wire;
- hoses and thermostat;
- coolant pump;
- carburetor or fuel injection system details;
- intake and exhaust manifold;
- oil filter;
- Suspension of engine parts;
- flywheel / leading disk manufacturer;
- rear plate.

Warning

Before the lifting of suspension assemblies put stickers on gaskets, seals and other details to facilitate assembly plants.

4. If it is determined block cylinders incomplete complete set (ie block cylinders with the crank-crank mechanism and piston Party), it should also remove the head of cylinders, oil and oily pallet pump.
5. If major repairs are scheduled to take place with complete disassembly, the engine must be completely dismantled, as follows:

- cap cylinder heads;
- intake and exhaust manifold;
- yokes and bars;
- camshafts (1FZ-FE engine);
- Cylinder head;
- push (2F engines and E-3F);
- oily pallet;
- oil pump;
- shatunno-Piston Group;
- with indigenous crankshaft bearings.

3.3.7.5. Cleaning and inspection of the cylinder block

BACKGROUND

Telescopic hole-gauge measuring the internal diameter

Cleaning

ORDER OF PERFORMING

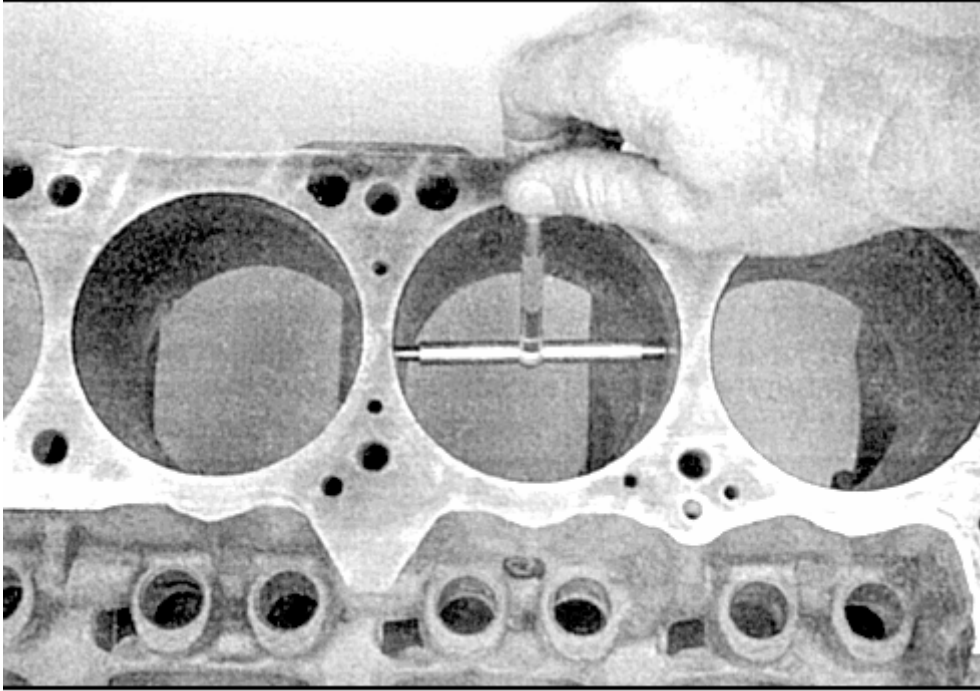

Warning

Plugs channels cooling system fitted tightly in block cylinders.

1. Remove the lid with liners, and the name of the store separately.
2. Carefully clean block from the remnants of compaction.
3. Vysverlite plugs block (to unscrew them virtually impossible), progonite threads and build, install new plugs.

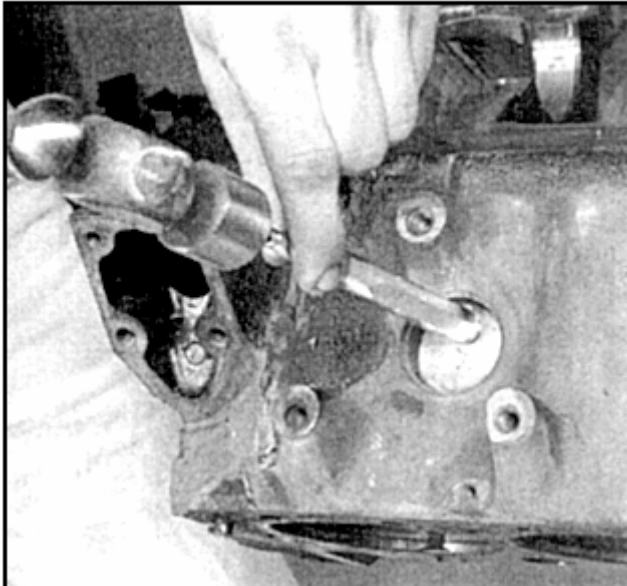

4. Vybeyte plugs cooling channels.

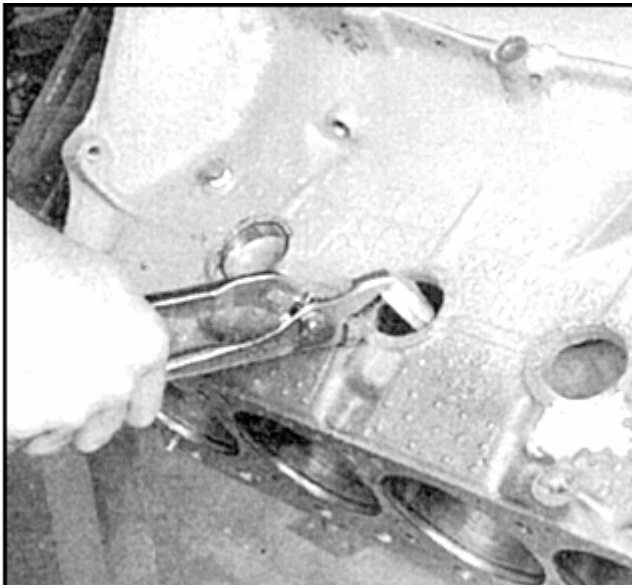

5. Get a cable plugs.

6. If a strong zanryaznenii očistite block all channels jet of steam and compressed air (recommended in the car wash), a block from the outside detergent wash tool. Progonite all threaded holes, and Purge compressed očistite air. Dry block and brush.

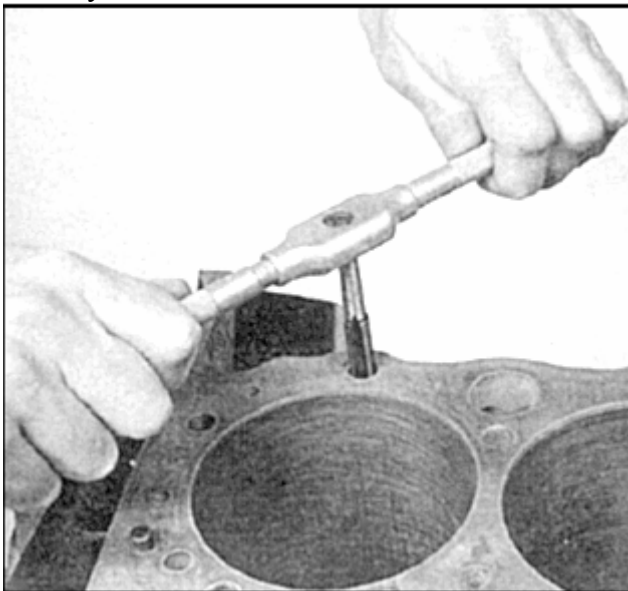

7. Progonite all threads of the cylinder block, thus clearing of dirt.

8. Set the lid indigenous bearings, tighten the screws by hand.

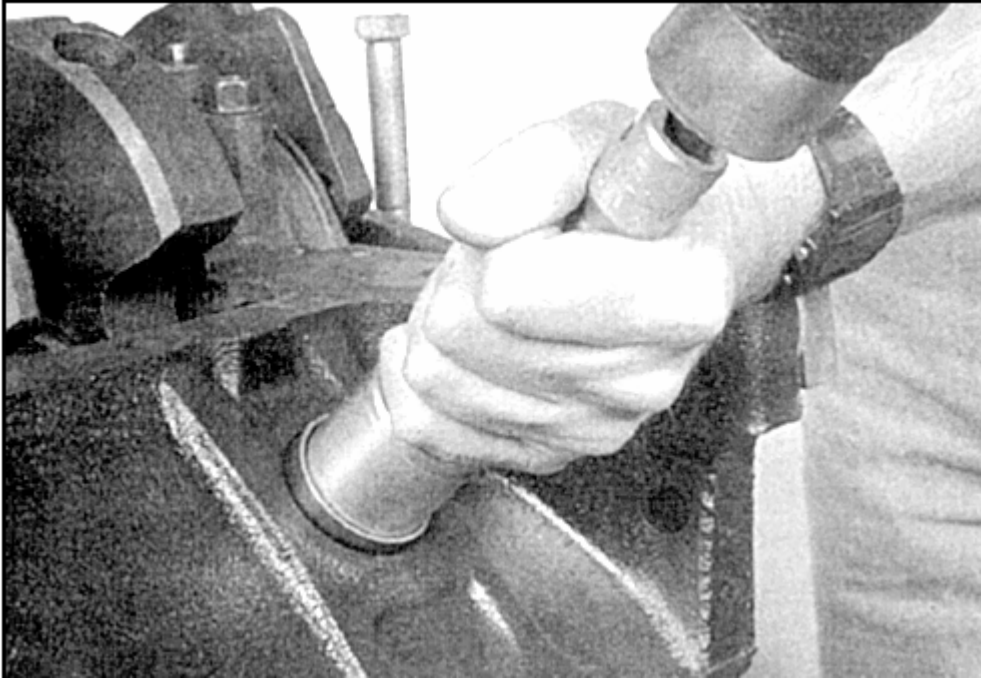

9. Zapressuyte new plugs without distortions,
their pre-coat sealant
Permatex N2. Wrap at the same sealants
new plugs oil channels. Tightly
tighten caps.
Checking

Rooms dimensional teams in each of the piston cylinders

1. In front of the engine

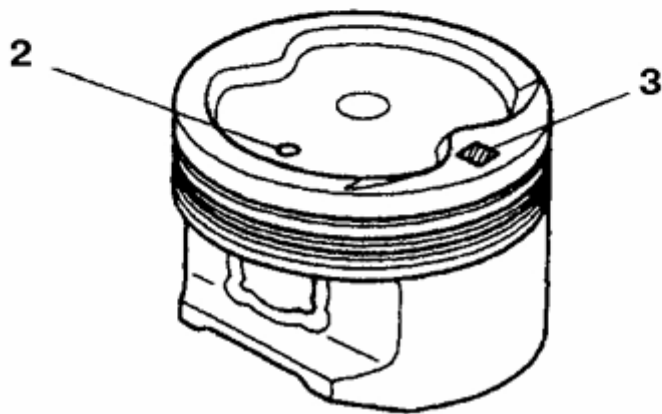
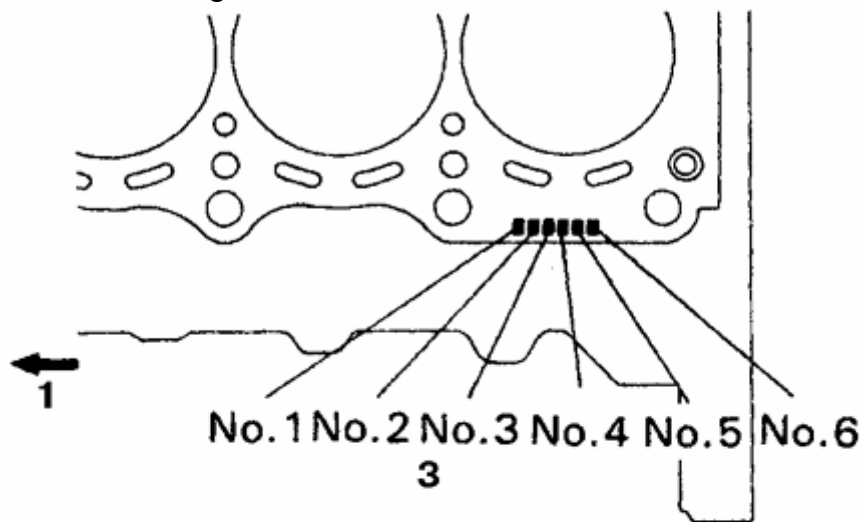

2. Orientation label
(toward the front of the
Engine)
3. Places 1, 2 or 3

ORDER OF PERFORMING

1. When there are external defects (cracks and chips), a block or repair replace. Recommended check for internal defects in block cylinders, which must pass block in the car.

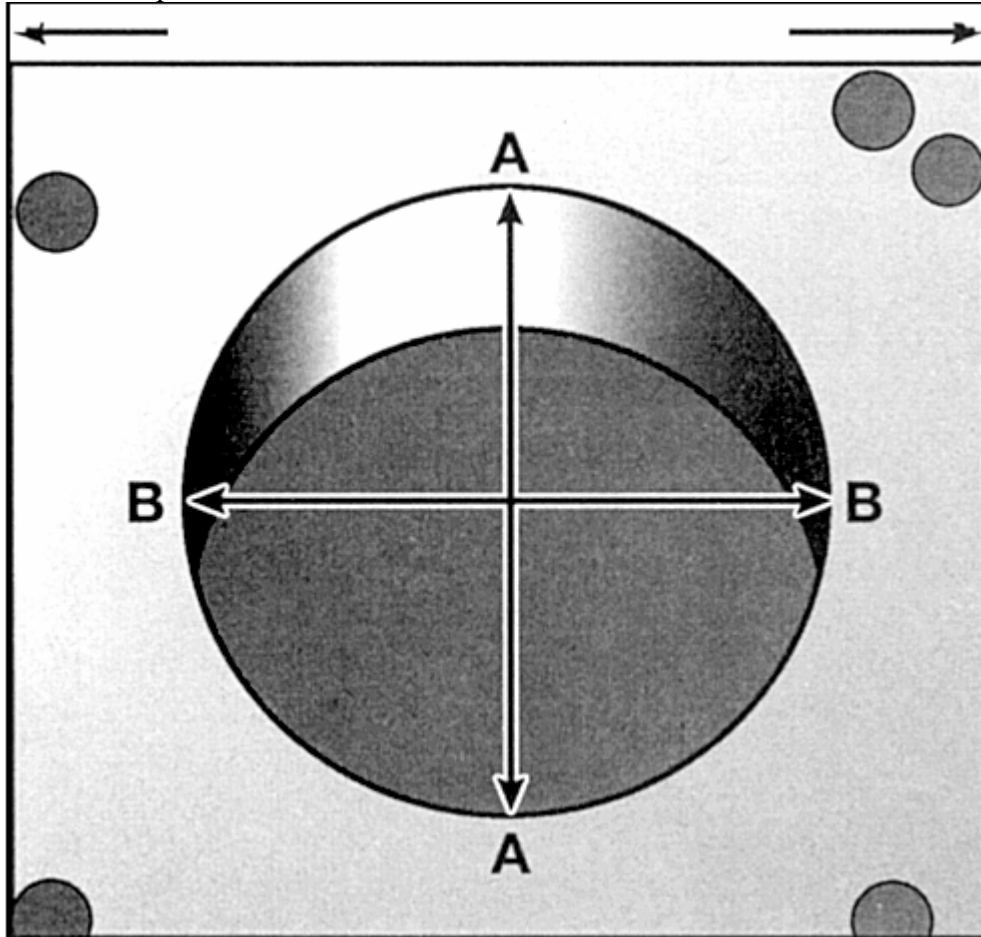

2. Check the surface, the gap between the piston and cylinder, and ovalness of cylinders by measuring the diameter of three planes, in the directions parallel and perpendicular to the axis of the block. If the results differ from the standard, it should be to bore out the cylinders. After rastrochki bloc needed pistons and rings repair sizes.
3. In the absence nutromera clearance can be checked by special long schupami about 300 mm. Insert the piston in the cylinder and check the appropriate course piston, paving the probe on major friction surfaces (in the direction perpendicular to the finger and thumb).
4. The gap is determined by the thickness of the probe, in which the piston moves in cylinder under moderate effort. If the piston slide or fails, it clearance above the rules and we need to change the piston and cylinder proshlifovat. If the piston stuck with the situation and probe about NMT slide in the probe about the situation TDC, the tgear cylinder higher than normal. If the turn of the piston in a cylinder with footsteps probe stuck piston, the cylinder ovalness higher than normal.
5. Standard diameter (size group) piston-engine 1FZ determined by the FE marking on the bottom stroke (group 1, 2 or 3, see Fig. Numbers size groups

pistons in each of the cylinders). Rooms at the piston must match the number on block associated with this cylinder.

6. If an acceptable state of cylinders, cylinder wear, and the gap between the cylinder and

the piston does not exceed the standards, it required only cylinders othonningovat (see sub-section 3.3.7.6).

7. For much of the engine pistons and liners provided (crankshaft and raspredvala) repair sizes. At blocks cylinders these engines are marks.

3.3.7.6. Honningovanie cylinders ORDER OF PERFORMING

1. For honningovaniya recommended use the "brush".

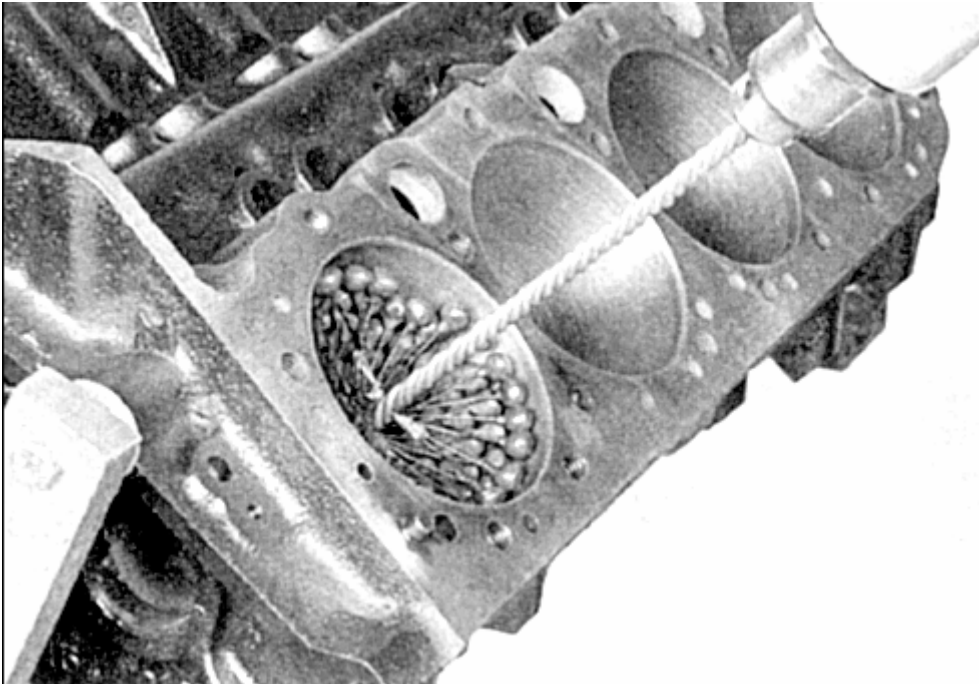

2. Even in elektrodrel device.

3. Good brush surface cylinder oil, and turn elektrodrel periodically move up and down in the cylinder.

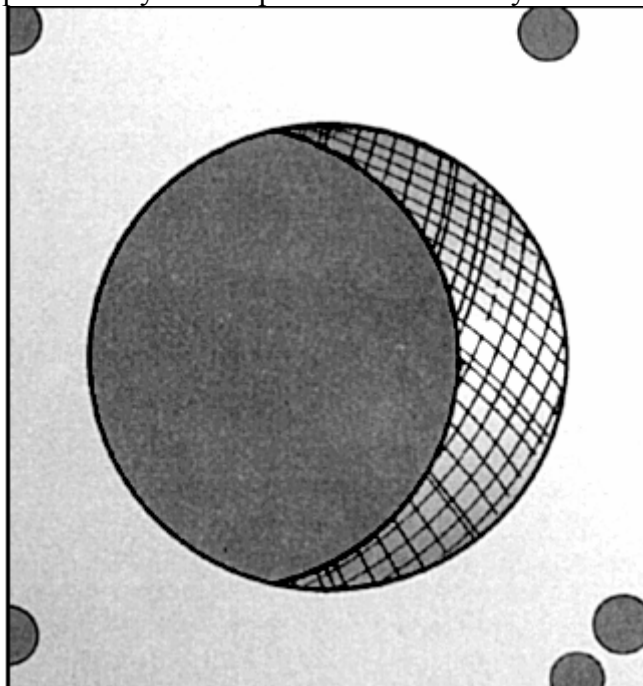

4. At that on the surface the cylinder wall Businesses should be formed of thin lines,

intersecting at an angle of about 60 °.
5. Yorshik get only after the drills

3.3.7.8. Indigenous and crankshaft bearings BACKGROUND

Indigenous and crankshaft bearings in the engine overhaul subject mandatory replacement, but the former bearings in service should be carefully check to restore the general condition of the engine at the time of repair.

Reasons for the destruction of crankshaft bearings are insufficient lubrication because of improper assembly, pollution and the entry of foreign particles, frequent overload the engine, corrosion, etc. Regardless of the reasons that caused the destruction of

of bearings, it should be corrected.

Types wear indigenous and rod bearings



Selection of indigenous bearings

Figure for selection rod bearings for engines E-3F

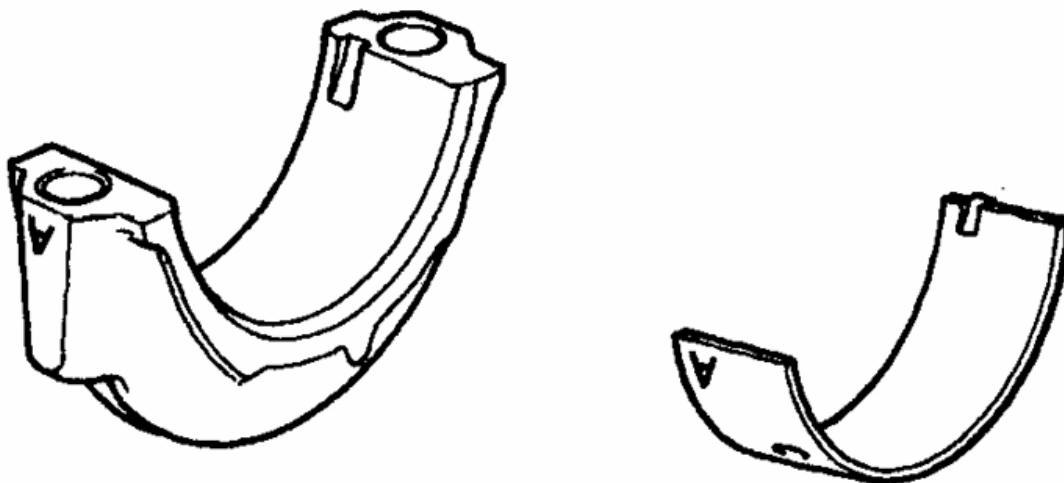

Marking A	1.484 - 1.488 mm
Marking V	1.488 - 1.492 mm
Marking S	1.492 - 1.496 mm

Figure for selection rod bearings on the crankshaft engines E-3F

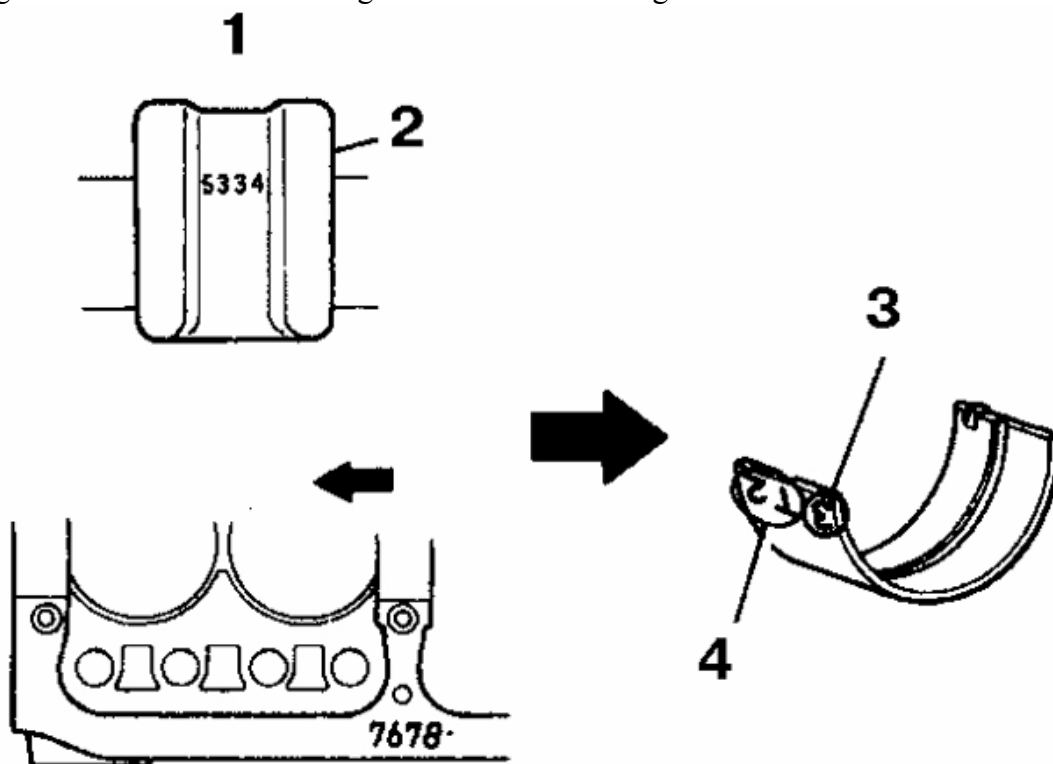

1. Crankshaft
2. Central opposed
3. Bearing N3
4. Dimensional group bearing

Markers bearings									
Rooms at the crankshaft	3			4			5		
Number of cylinders at Unit	6	7	8	6	7	8	6	7	8
Dimensional group bearing *	T3	T4	T5	T2	T3	T4	T1	T2	T3

* Example: Room at the crankshaft 5, No. 7 on the block cylinders T2 = dimensional team.

The diameter of the root ball bearings and the inner diameter of the root of bearings for engines E-3F

Neck diameter crankshaft	№	mm
Marking-3	N1	66,972 - 66,980
	N2	68,472 - 68,480
	N3	69,972 - 69,980
	N4	71,472 - 71,480
Marking-4	N1	66,980 - 66,988
	N2	68,480 - 68,488
	N3	69,980 - 69,988
	N4	71,480 - 71,488
Marking-5	N1	66,988 - 66,996
	N2	68,488 - 68,496
	N3	69,988 - 69,996
	N4	71,488 - 71,496
The diameter hole under the root bearings	N	mm
Marking-6	N1	72,010 - 72,018
	N2	73,510 - 73,518
	N3	75,010 - 72,018

	N4	76,510 - 76,518
Marking-7	N1	72,018 - 72,026
	N2	73,518 - 73,546
	N3	75,018 - 75,026
	N4	76,518 - 76,526
	N1	72,026 - 72,034
Marking-8	N2	73,526 - 73,534
	N3	75,026 - 75,034
	N4	76,526 - 76,524

Figure for selection of standard rod bearings for engines 1FZ-FE

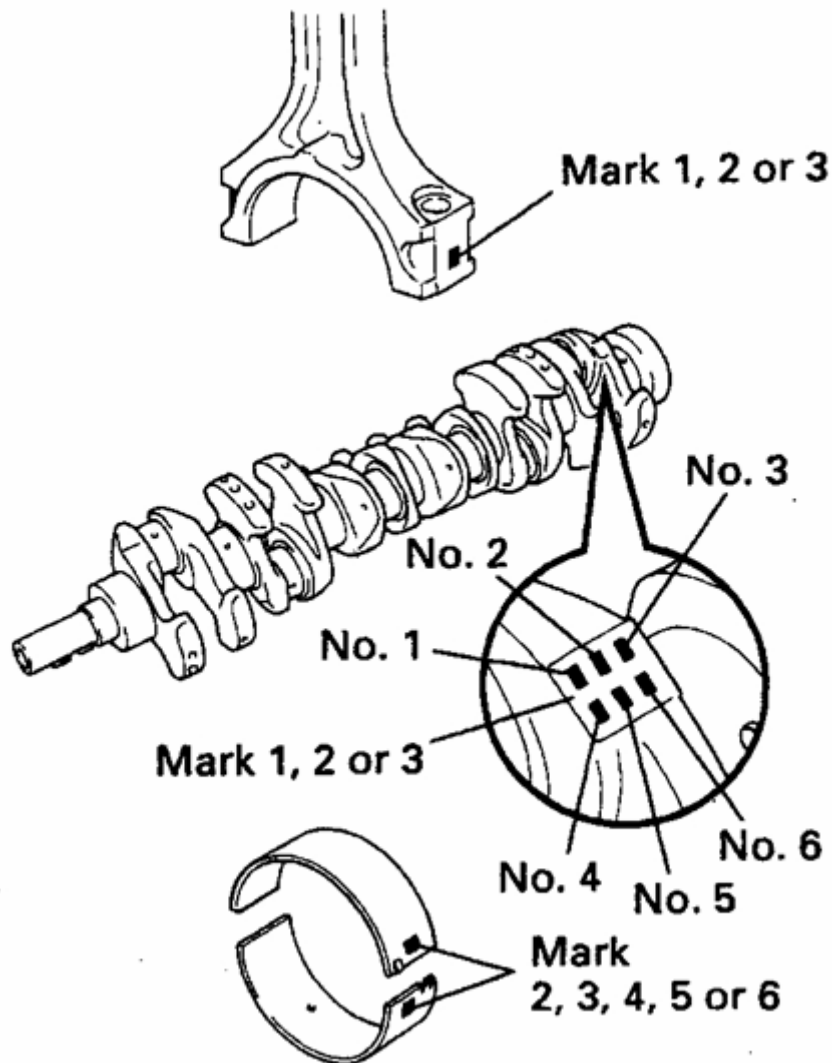

	Caused room								
	1			2			3		
Markers crank									
Rooms at the crankshaft	1	2	3	1	2	3	1	2	3
Marking size group bearing *	2	3	4	3	4	5	4	5	6

* **Example:** Number 3 + crank on the number at 1 = crankshaft bearing Dimensional

* Example: Number 3 + crank on the number at 1 = crankshaft bearing Dimensional Group 4.

Figure standard for selection of indigenous bearings on the crankshaft
- FE engines 1FZ

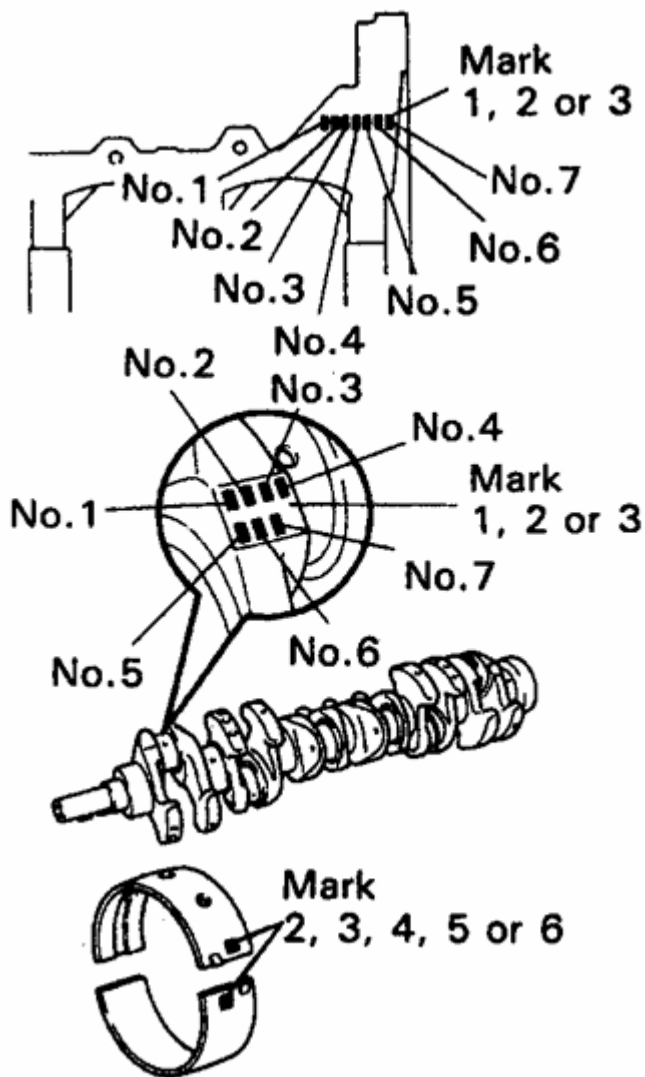

	Caused room								
	1			2			3		
Markers block cylinders									
Rooms at the crankshaft	1	2	3	1	2	3	1	2	3
Marking size group bearing *	2	3	4	3	4	5	4	5	6

* Example: Number of cylinders at Unit 2 + room at the crankshaft 1 = Dimensional Group
 3 bearing.
 The diameter of the root ball bearings and the inner diameter of the root of bearings for engines 1FZ-FE

The diameter hole under the root bearings:	
-- marking 1	74,026 - 74,032 mm
-- marking 2	74,032 - 74,038 mm
-- marking 3	74.03 - 74,044 mm
Neck diameter crankshaft:	
-- marking 1	68,994 - 69,000 mm
-- marking 2	68,988 - 68,994 mm
-- marking 3	68,982 - 68,988 mm
The thickness of standard bearings:	
-- marking 2	2,489 - 2,492 mm
-- marking 3	2.49 - 2,495 mm
-- marking 4	2,495 - 2,498 mm
-- marking 5	2,498 - 2,501 mm
-- marking 6	2,501 - 2,504 mm

ORDER OF PERFORMING

1. If the bearings are set standard size groups, the new bearing selected numbers caused to the exchangeable, as well as by numbers on the block, crankshaft and cylinders using spreadsheets.
2. If shlifovalsya crankshaft, the bearings should be collected in the car - in which was performed by grinding.
3. After selection of bearings measure the gap in the neck (see sub-section 3.3.8.2).
4. In the factory during assembly of engine bearings with different sets color marking, which is sprayed on the edge of the liner bearing.
5. Marking size group bearings usually is caused by the liner facing the rear of the crankshaft, with the exception of the rear-indigenous liner, which is marked by the call to the front of the crankshaft.
6. Allowed to set upper and lower liners of different size groups. For example, to adjust the gap to 0.0125 mm standard liner sometimes used with a liner in the group with a reduced diameter at 0025 mm.

Warning

Never use a couple of liners difference if their diameters greater than 0.025 mm. Different-sized liners should be installed either all the top, or bottom.

3.3.8.2. Crankshaft Mounting

ORDER OF PERFORMING

1. Place the block so that the lower part was up.
2. Remove the screw cap, dostante lids and arrange them in order of installation.
3. Get a cap of the cylinder block and the old liners and wipe nachisto covers and bed.
4. Clean the outside of the new liners with indigenous oil grooves, and gently place in the bed of the cylinder block.
5. Appropriate Response liners invest in a cover by aligning with the projections samples.
6. Inserts not lubricated.

Checking spacings

ORDER OF PERFORMING

1. Set tenacious semirings in deepening the cylinder block. At engines and 2F E-3F semirings installed next to the backbone 3 - go bearing on the engines 1FZ - FE - next to the drawing 4 - On the bearing.

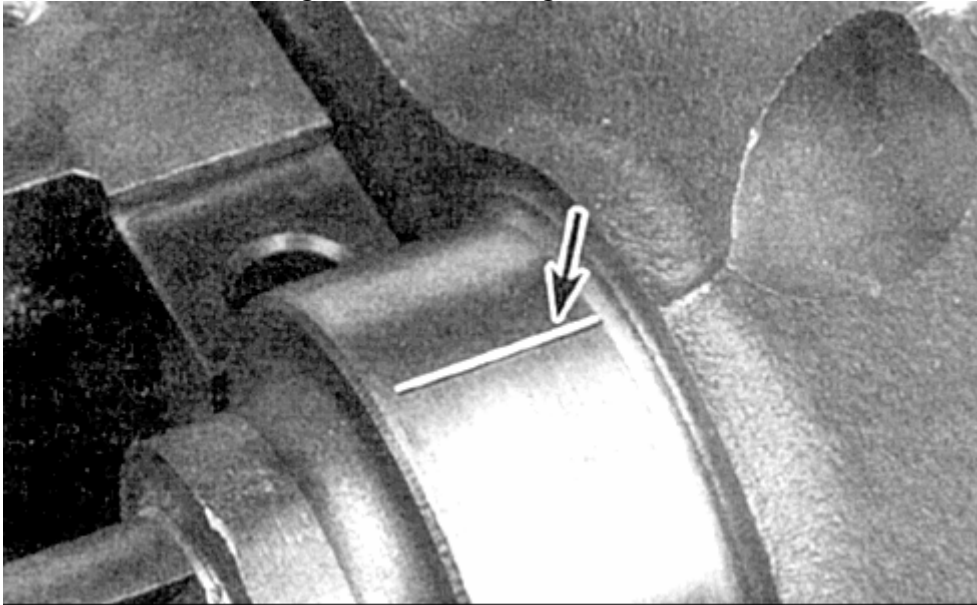

2. Set the crankshaft and measure the gap in Indigenous liners. To put this in legs gauge wire (shown arrow) per root-neck crankshaft along its axis.

3. Clean the surface liners in the lid, set the lids and tighten the screws three reception with a given moment, starting from the center and moving to the periphery.

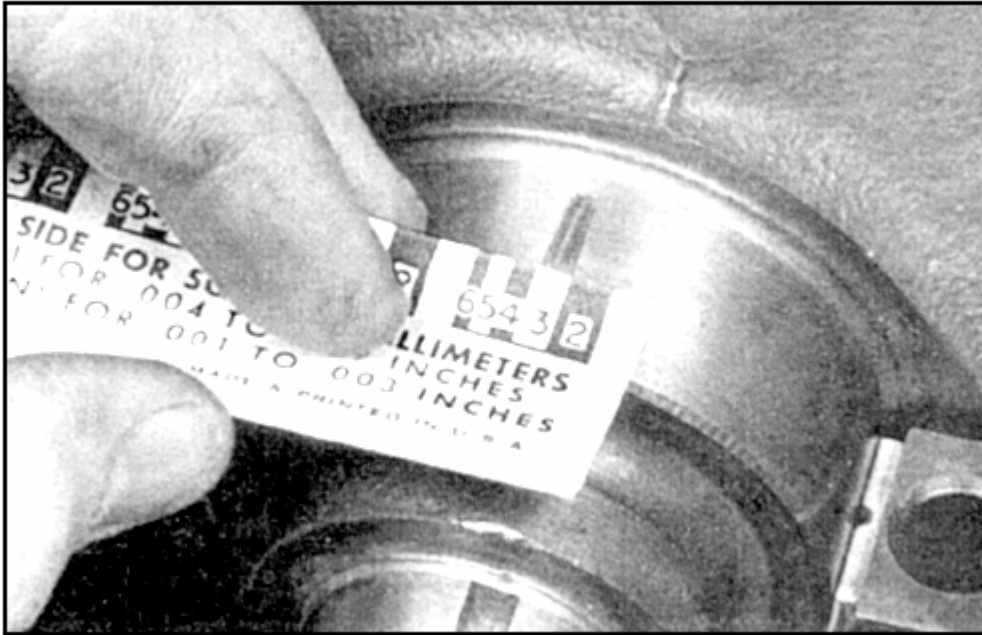

4. Reject bolts and gently lift lids, compare the thickness of each of the crushed wires on the scale package and determine the value gap. Rotation crankshaft of measurement is not permitted.
 5. If there is a gap does not comply with rules, the reason might be the wrong selection size group liners.
 6. Make sure dimensions of the bearing surfaces and lids absent or oil pollution. If crushed width of the wire very different ends, the crankshaft is a fundamental tgear neck.
 7. Remove the tails from the remnants of the wire and remove the crankshaft.
 8. Lubricated frying molybdenum root surface liners and tortsovuyu Indigenous bearing persistence. Set in the rear section of a block of cylinders (split) glands and rear cover indigenous bearing.
- Final installation crankshaft
ORDER OF PERFORMING

1. At 1FZ-FE engine, set in the block Cylinder oil atomizer and checklists valves.

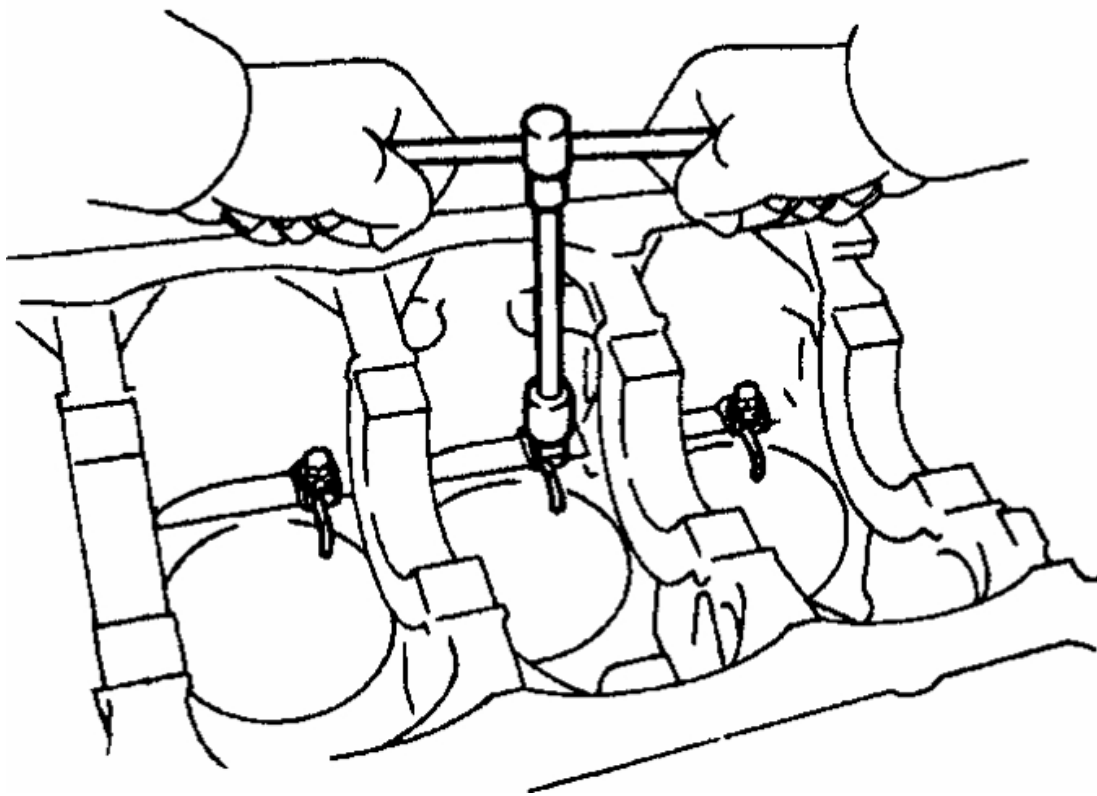

2. Ensure clean necks crankshaft, and then set it in the block cylinders. Clean the surface liners in the lid and put each of them thin layer of lubrication.
3. Set the lid on their former places, so that the arrows have been turned into side of the front of the engine.
4. Wrap the root bearing cap bolts.
5. Tighten all screws lids stubborn lids apart from the indigenous bearing the given moment. Bolts drag in 3 stages, starting from the middle part and moving to the periphery.
6. GCSE indigenous stubborn bolts lid bearing the moment 1,0-1,2 N.m.
7. Light blows a lead or brass hammer slide crankshaft ago, to combine tenacious root surface and the crankshaft bearings.
8. Loosen the bolts and re-tighten the lids with a given moment, from and the middle part of moving to the periphery.
9. For cars with an automatic transmission to replace the guide bearing crankshaft.
10. Check the freedom of crankshaft rotation.
11. Check the crankshaft axis movement (see sub-section 3.3.7.4). Luft should conform to the rules, if installed new bearings and tenacious semirings not worn.
12. For cars with rear nerazemnym gland install a new rear gland.

3.3.7.4. Crankshaft

Dismantling

ORDER OF PERFORMING

Warning

Crankshaft can be removed only after the dismantling of the engine from the car. Pre-un-drum (or leading disk), pulleys, relaxing, belt (chain), a pallet, Oil, oil pump, and the front cover with a crank pistons.

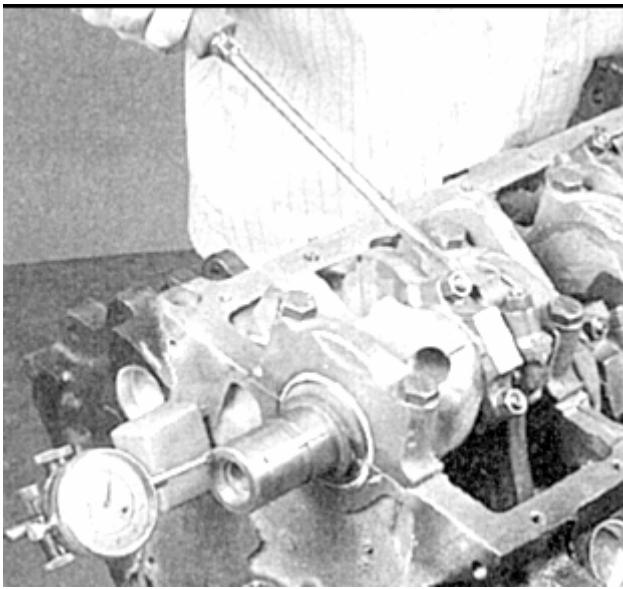

1. As always axial movement crankshaft.
2. Ročico crankshaft to the rear of the engine, making the maximum effort, and in this situation the scale indicator set at zero.
3. Then tolknite crankshaft shaft in the front of the engine and consider testimony indicator. The amount is equal to the distance of axial play, which moved shaft. If the axial movement exceeds normative value, the check worn surfaces persistent cheeks crankshaft. If they wear little, the play skorrektirovatsya must root replacement with new liners.

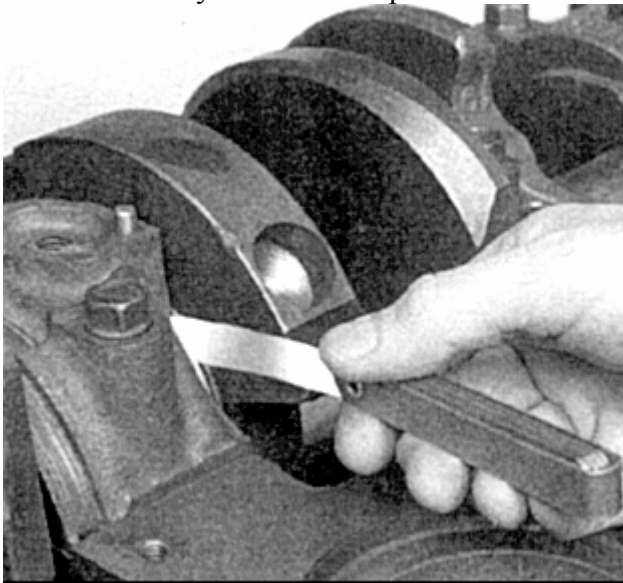

4. In the absence of an indicator head play can be measured using a set of probes.

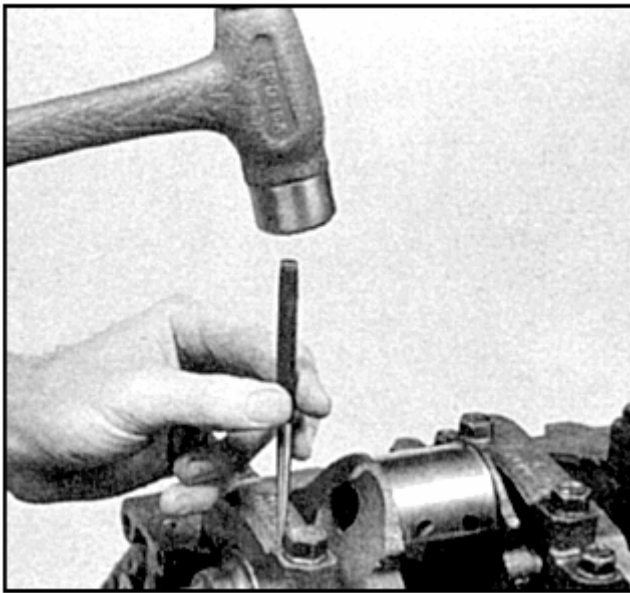

5. Gently move toward crankshaft front of the engine and measure the axial Luft, paving the probes between cheek crankshaft and end persistent indigenous bearing.

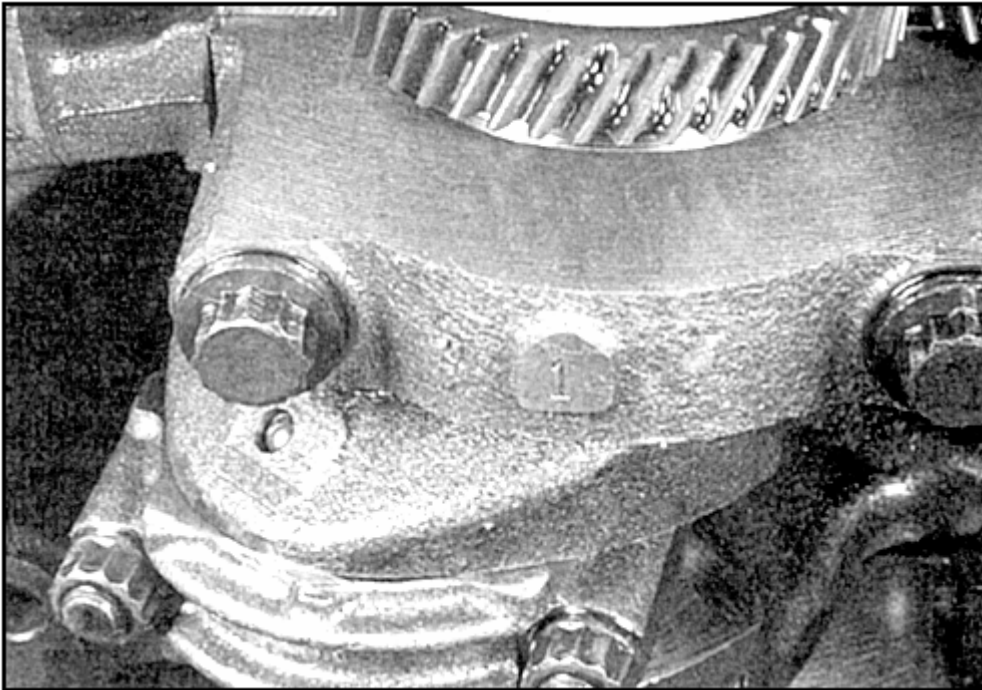

6. Make sure you have the lid on orientation arrows and marking numbers cylinder. Usually lids are numbered starting from the front of the engine available arrows are pointing in the direction front of the engine. If labelling not, the nachernite tag.

7. Loosen the bolts on the cap 1 / 4 turnover for a reception in until no bolts will turn away from the hand. When assembling bolts should be screwed to the old seats. Keep in mind that the engine parts are used as bolts pins, which also must wrap former places.

8. Gently move and lift their lids together with the liner.

9. Carefully uncheck the crankshaft. Leave protochkah liners in the cylinder block and cap. Put a lid on their seats and tighten the screws by hand.

Checking

ORDER OF PERFORMING

1. Crankshaft shaft solvent rinse and dry, oil očistite channels, clear neck and remove nadfilem rework.

2. Check the shaft necks, the presence of cracks, pock, scores. Check roughness fattened by rubbing them on a copper coin. If traces remain, the Neck pereshlifovat should. Recommended perform internal fault detection crankshaft.

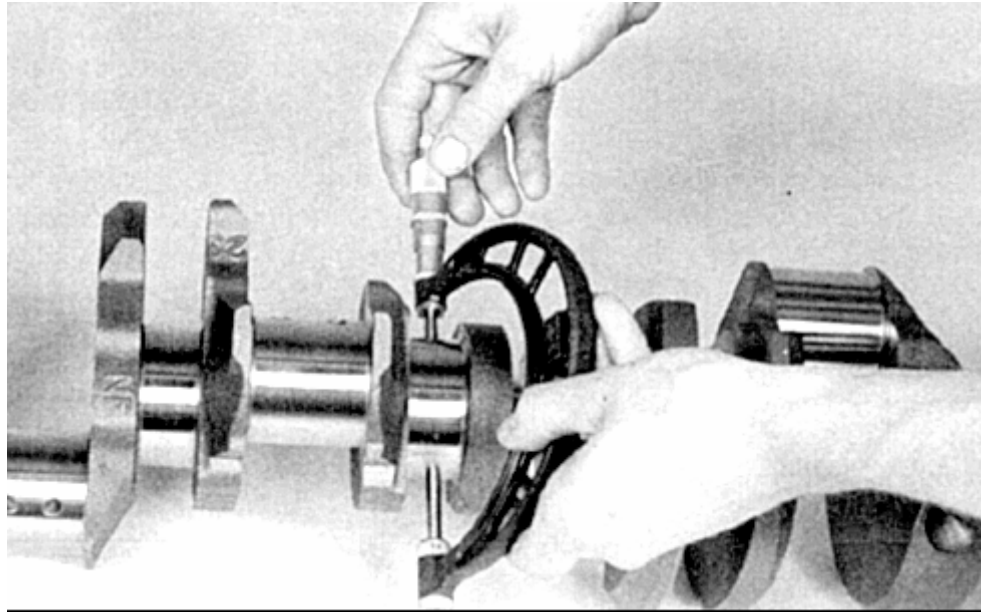

3. Measure the diameter of a few necks tgear ground, and define and ovalnost.

4. When visible injuries crankshaft to be replaced and pereshlifovat repair liners.

5. If the neck of seals formed deep grooves of the working edge gland, there are scratches or other damage, it is recommended crankshaft replace, or in the car-prokonsultrovatsya where possible to bore out the neck and napressovat sleeve.

4.1. Technical Specifications

BACKGROUND

Pressure plugs radiator valve actuation	0.6 - 1.0 bar
The temperature thermostat alarm	83 - 95 ° C
Tip conditioning refrigerant in the system:	
-- 1993 inclusive g.	R12
-- 1994 g.	R134 A
A gas coolant	795 - 910 g (on vehicles with air-conditioning rear of the passenger compartment - 1500 g)

Tightening moments (in Nm)

Bolts thermostat:	16.8 - 18
-- 1992 inclusive g.	15.6
-- 1993 g.	15

Bolts pump coolant:	
-- 1992 inclusive g.	33
-- 1993 g.	18

4.3. Thermostat BACKGROUND

Thermostat-FE engine 1FZ

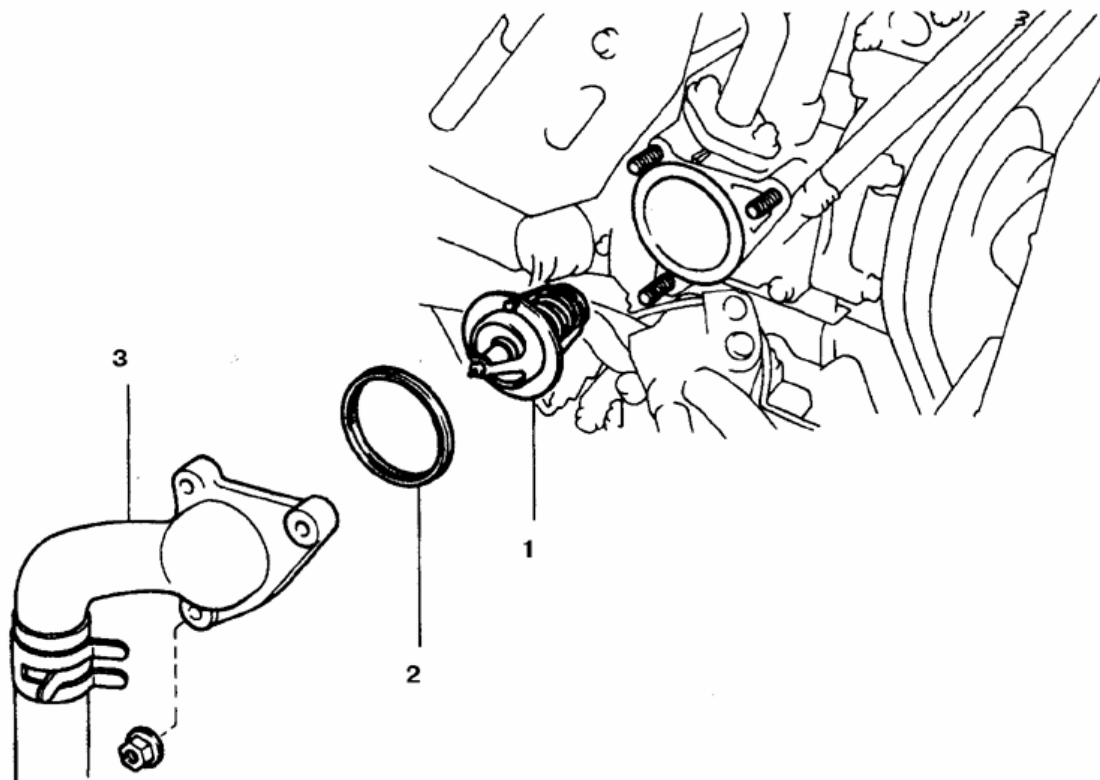

1. Thermostat
2. Gasket
3. Air inlet duct

Warning

Work performed at cold start with the observance of safety measures (poisonous antifreeze).

Checking

ORDER OF PERFORMING

1. Before we conclude, check the thermostat failure rate fluid pump belt state and the functioning of the temperature index (or a control lamp).
2. When the engine warms long (it can be determined on a slow mounting temperature of the marker, or a slow heating of the air heater), the likely cause is a sticking valve thermostat. This case thermostat replaced.
3. When the overheating engine check heating upper radiator hose. If the hose warm, and the engine is hot, the thermostat is closed, access fluid from perekryvaya engine to the radiator. Replace the thermostat.

Warning

For cars with an injector engine driving without thermostat prohibited. When

no thermostat razmykaetsya feedback circuit automatically systems management and reduce the toxicity of the fuel supply system, as a result of Engine efficiency falls.

Replacing

ORDER OF PERFORMING

1. Disconnect the battery from the weight of the liquid and stir.
2. Disconnect the vacuum hoses from the thermostat (if provided).
3. Remove the thermostat, you can not hose disconnect from the main body.

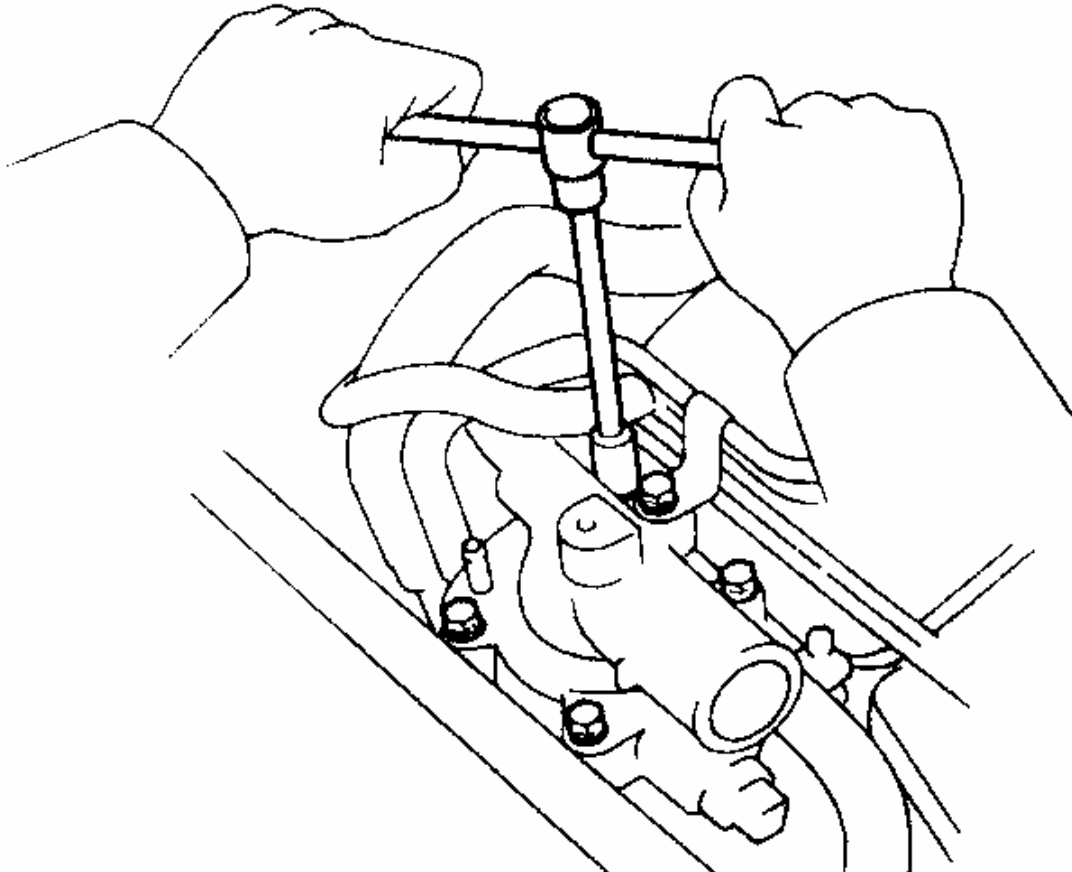

4. Get a thermostat, drawing attention to his orientation (spring is the thermostat to the engine).

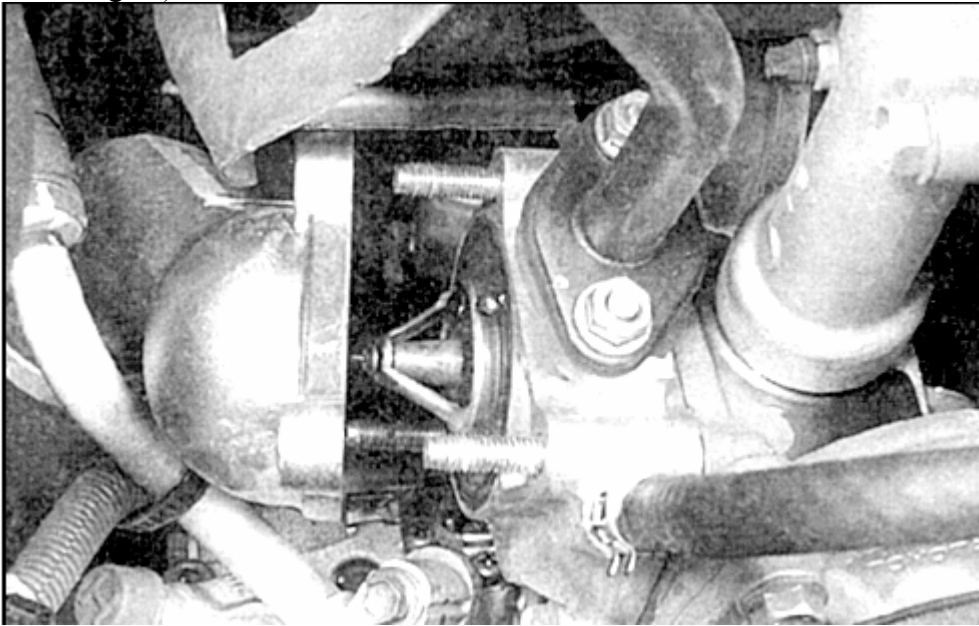

5. Carefully remove the old seal.



6. Replace gasket (1993 g. gasket fit on the edge of the thermostat and is a sealing ring with grooves), and set sorientiruyte thermostat.

7. Tighten bolts.

8. Pour liquid, and make sure the engine is run in the absence of a leak.

4.6. Masloohladitel GENERAL BACKGROUND

Masloohladitel engine 3F-E Masloohladitel engine E-3F

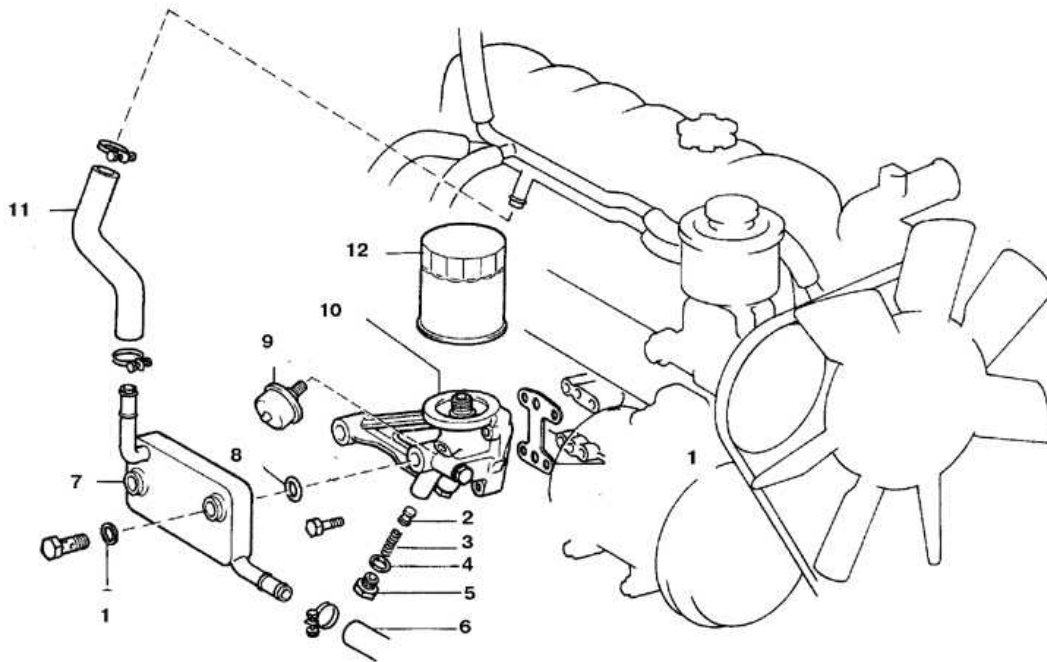

- 1, 4. Seal Gasket
- 2. Expansion valve Expansion valve
- 3. Spring Spring
- 5. Stub Stub
- 6, 11. 6, 11. Hose coolant Hose coolant
- 7. Masloohladitel Masloohladitel
- 8. Ring Ring
- 9. Pressure sensor Oil Oil pressure sensor
- 10. Bracket Bracket
- 12. Oil filter Oil filter

Masloohladitel 1FZ-FE engine

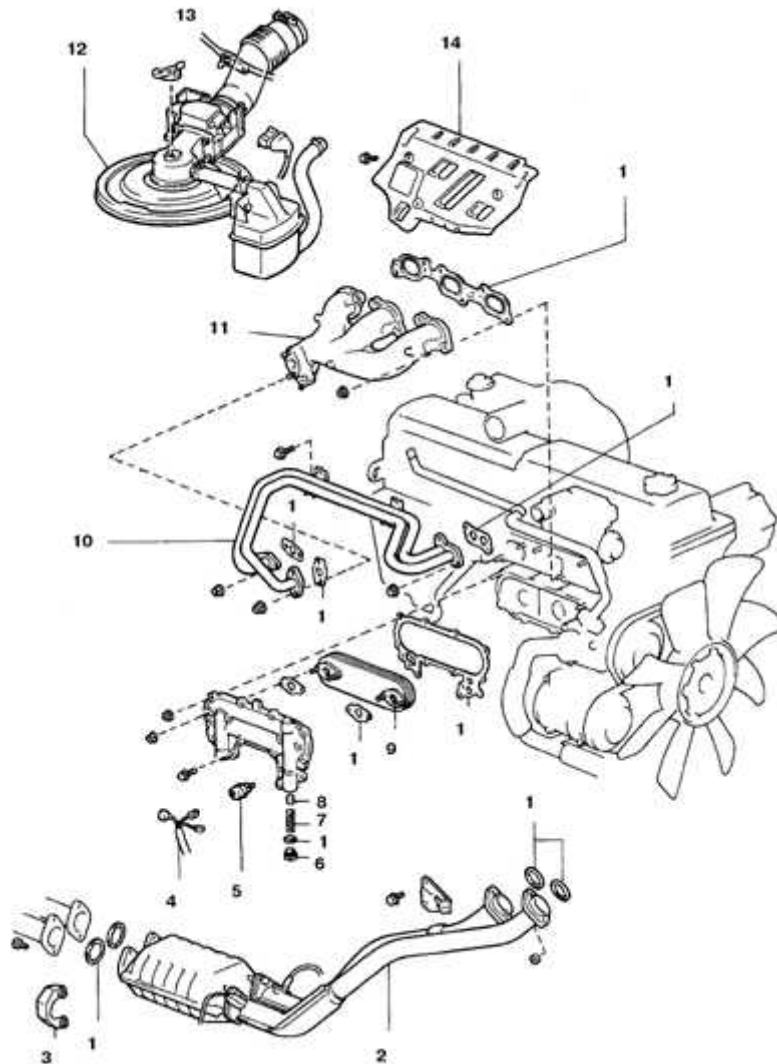

1. Seal Gasket
 2. The front exhaust pipe The front exhaust pipe
 3. Holder Holder
 4. When Wiring
 5. Pressure sensor Oil Oil pressure sensor
 6. Stub Stub
 7. Spring Spring 8. Expansion valve Expansion valve
 9. Masloohladitel Masloohladitel
 10. The air tube The air tube
 11. Exhaust manifold 1 Exhaust manifold 1
 12. Measurement of flow and resonator Measurement of flow and resonator
 13. Cover air filter Cover air filter
 14. The heat shield The heat shield
- Removal and installation

IMPLEMENT THE ORDER OF ORDER OF PERFORMING

1. Disconnect the battery from the masses. 1. Disconnect the battery from the masses.
2. Drain liquid. 2. Drain liquid.
3. Remove the air filter. 3. Remove the air filter.
4. Disconnect from the front exhaust pipe collector. 4. Disconnect from the front exhaust pipe collector.
5. Disconnect the air tube pulsed-PAIR system (if provided). 5. Disconnect air tube pulsed-PAIR system (if provided).
6. At the car after release in 1993, uncheck the exhaust manifold. 6. Vozila release in 1993 after graduating un-collector.
7. Remove the oil pressure sensor. 7. Remove the oil pressure sensor.
8. Disconnect hoses. 8. Disconnect hoses.

9. Reject and remove the bolts masloohladitel. 9. Otvernite bolts and remove the masloohladitel.
10. Installation is performed in reverse order 10. Installation is performed in reverse order

4.7. The pump cooling system The pump cooling system GENERAL BACKGROUND

Engine coolant pump 3F-E The pump engine coolant E-3F

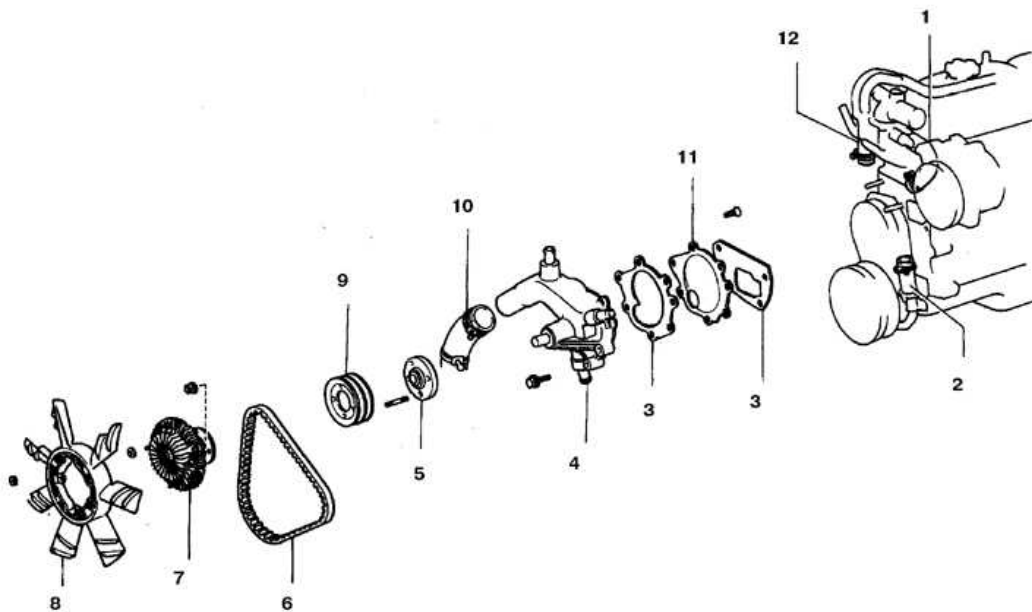

1. Substantial hose Substantial hose
2. Hose PET Hose PET
3. Seal Gasket
4. The pump pump
5. Sheaves flange Flange sheaves
6. A belt drive A belt drive 7. Boxes boxes
8. Impeller Impeller
9. Pulleys Pulley
10. Inlet hose Inlet hose
11. Plastina pump Insert the pump
12. Hose heater hose heater

Engine coolant pump 1FZ-FE

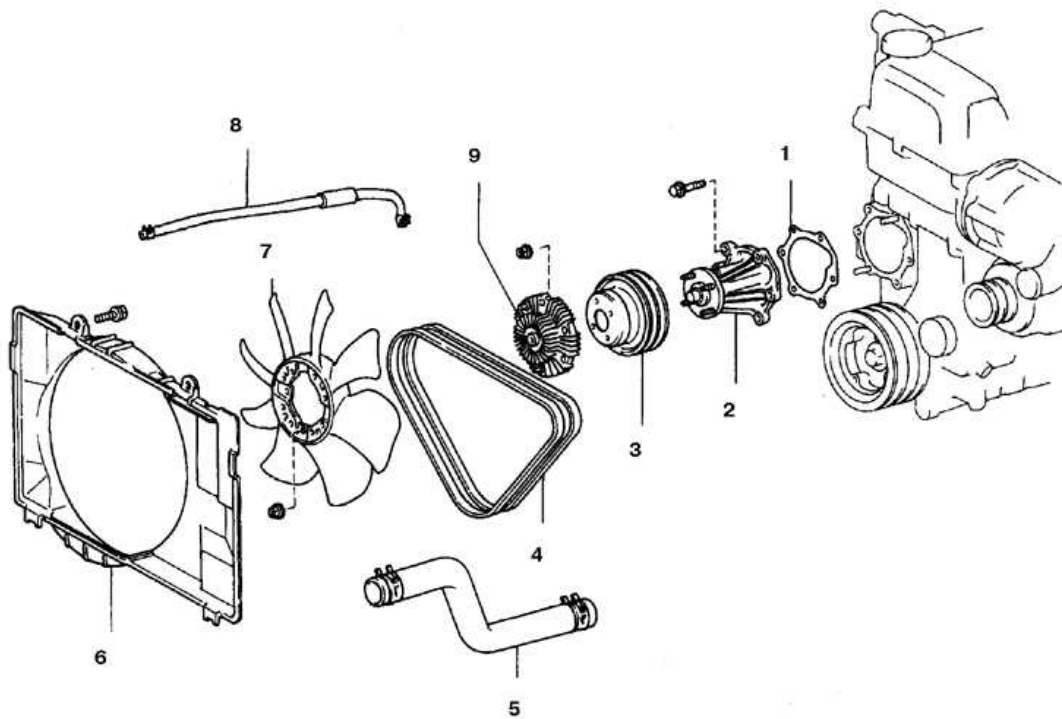

1. Seal Gasket
2. The pump pump
3. Pulleys Pulley
4. A belt drive A belt drive
5. Inlet hose Inlet hose
6. Casing Casing
7. Impeller Impeller
8. Substantial hose Substantial hose
9. Boxes boxes

Checking Checking

IMPLEMENT THE ORDER OF ORDER OF PERFORMING

1. On the engine running progetom cautiously perezhmite upper radiator hose and gradually letting go. 1. working on the engine progetom cautiously perezhmite upper radiator hose and gradually letting go. With proper pump in the hose must be felt pressure fluids. With proper pump in the hose must be felt pressure fluids.

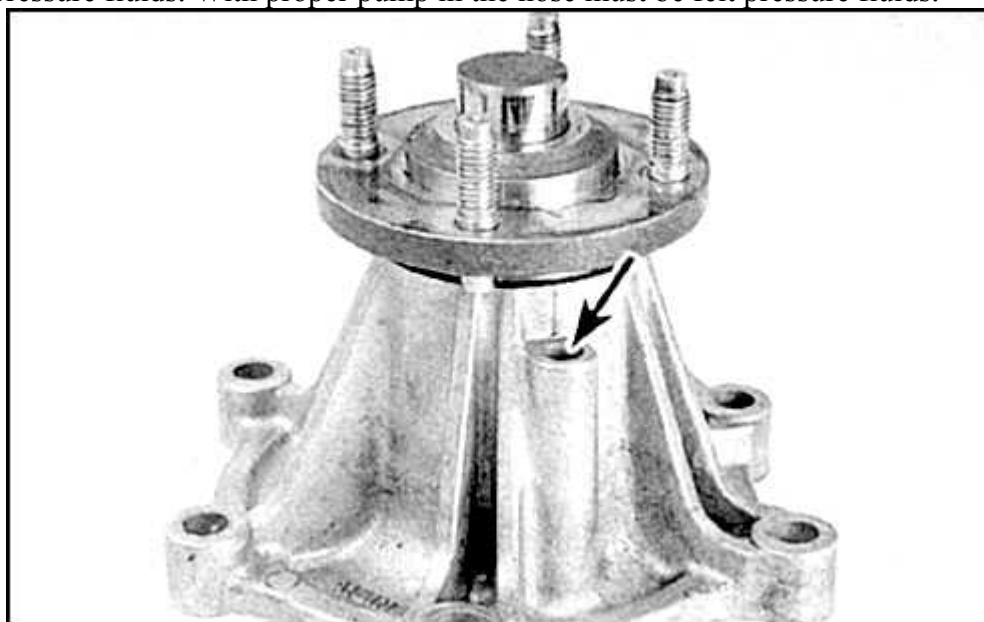

2. At the pump provided checklist hole for the flow of liquid. 2. checklist provided in the pump hole to drain fluid. When failure of the gland through the checklist hole pump cooling liquid is derived. When failure of the gland through the checklist hole pump cooling liquid is derived. To find a hole, it is necessary to illuminate the space for

guided flange pump, just below the shaft. To find a hole, it is necessary to illuminate the space for guided flange pump, just below the shaft.

3. Depreciation bearings can be determined, pokachivaya pump up and down, and the typical howls at the front of the engine. 3. Depreciation bearings can be determined, pokachivaya pump up and down, and the typical howls at the front of the engine.

4. Close to tone sound and may issue proskalzyvayuschy belt drive, so it can be erroneous conclusion pump malfunction. 4. Blizky tone of the sound and can issue proskalzyvayuschy belt drive, so it can be erroneous conclusion pump malfunction.

5. To exclude the sound of a belt put spraying special train for automotive belts. 5. order to exclude sound from the belt, put a sputtering special train for automotive belts.

Removal and installation Removal and installation

IMPLEMENT THE ORDER OF ORDER OF PERFORMING

1. Disconnect the battery from the masses and drain coolant (see 2.38). 1. Disconnect the battery from the masses and drain coolant (see 2.38).

2.38. Care Cooling Caring for Cooling GENERAL BACKGROUND

Location drain plugs coolant Location coolant drain stoppers

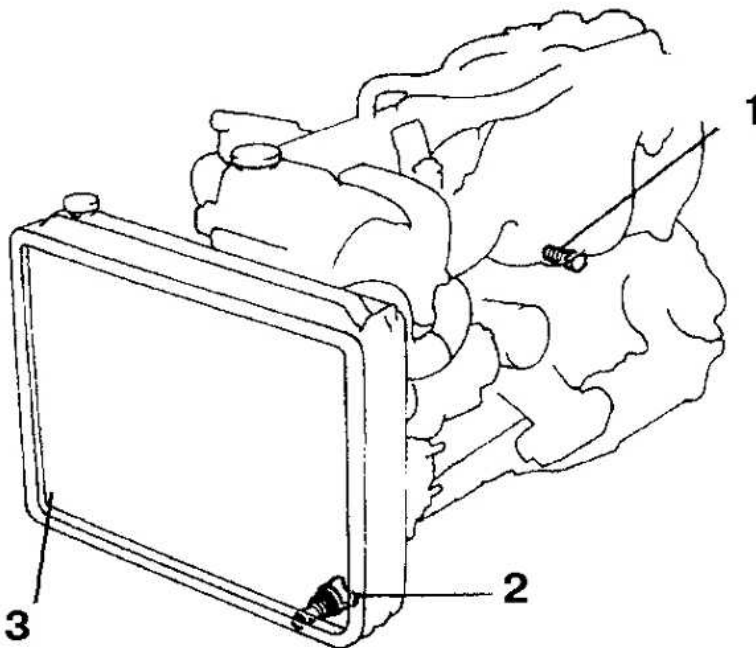

1. Drain plug of the cylinder block (all cars) Drain plug of the cylinder block (all cars)

2. Radiator drain plug into cars late issuance of Radiator drain plug into cars late issuance

3. Radiator drain plug into cars early release Radiator drain plug into cars early release

Warning Warning

Work performed at cold start, subject to precautionary measures (poisonous antifreeze). Work performed at cold start, subject to precautionary measures (poisonous

antifreeze).

Replacement fluid and flushing Replacement fluid and flushing

IMPLEMENT THE ORDER OF ORDER OF PERFORMING

1. Substitute receptacle radiator drain plug. 1. Substitute receptacle radiator drain plug.

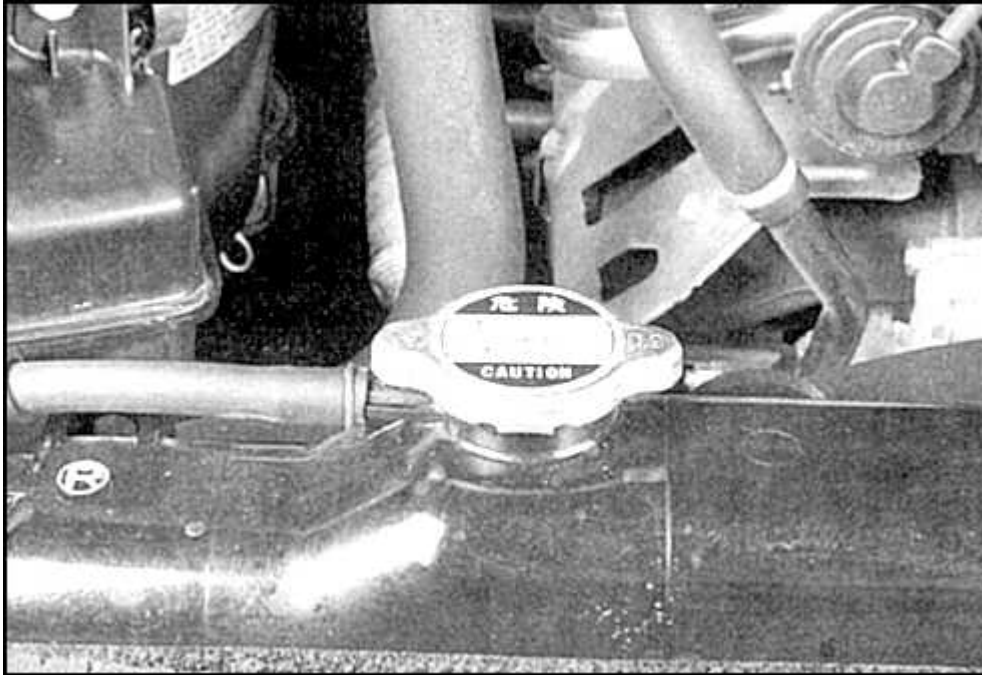

2. Two cable reject drain cork stoppers and neck radiator (click and turn against chasosoy arrows). 2. two cable reject drain cork stoppers and neck radiator (click and turn against chasosoy arrows). Drain liquid. Drain liquid. Then reject cork and pour liquid from the cylinder block (if not liquid poletsya, probeyte screwdriver rust in a drain hole). Then reject cork and pour liquid from the cylinder block (if not liquid poletsya, probeyte screwdriver rust in a drain hole).

3. Check and, if necessary, replace damaged cooling system hoses. 3. check and, if necessary, replace damaged cooling system hoses.

4. Radiator flush jet of pure water (only removes sediment), as required special wash detergent (removes layers of rust). 4. Promoyte radiator jet of pure water (only removes sediment), as required special wash detergent (removes layers of rust). If rinsed radiator fails, or if there are notable damage and leaking, and the un-sealed in the radiator repair. If rinsed radiator fails, or if there are notable damage and leaking, and the un-sealed in the radiator repair.

5. Disconnect the hose pans, pour liquid rinse batter and roll hose. 5. Disconnect hose pans, pour liquid rinse batter and roll hose.

6. Tighten both drain plugs. 6. Tighten both drain plugs.

7. Translate trying heater in the position of maximum heat. 7. Transfer Layer heater in the position of maximum heat.

8. Pour liquid (in a ratio of 50/50 water and antifreeze) to the bottom mark pans. 8. Pour liquid (in a ratio of 50/50 water and antifreeze) to the bottom mark pans.

9. Without closing cork radiator, the engine progreyte prior to the opening of the thermostat (there is a ceiling on heating hose). 9. Without closing cork radiator, the engine progreyte prior to the opening of the thermostat (there is a ceiling on heating hose).

10. Stop the engine and after cooling liquid fill to the edge of neck, push on the hose, remove air, then wrap cork. 10. Stop the engine and after cooling liquid fill to the edge of neck, push on the hose, remove air, then wrap cork.

11. Start the engine and check in the absence of a leak. 11. Start the engine and check in the absence of a leak.

2. Remove all hinged belts units. 2. Remove all hinged belts units.

3. Motor vehicles until 1992 un-movie mortgage belt and the air conditioner bracket, as well as mounting bracket generator. 3. Motor vehicles until 1992, the un-movie mortgage belt and the air conditioner bracket, as well as mounting bracket generator.

4. Remove the fan casing and the fan (see 4.4). 4. Remove the fan casing and the fan (see 4.4).

4.4. The impeller fan and hydro The impeller fan and boxes Checking Checking

IMPLEMENT THE ORDER OF ORDER OF PERFORMING

1. When there are cracks in the blades or play on the shaft impeller, the impeller replaced. 1. If we find cracks in the blades or play on the shaft impeller, the impeller replaced.

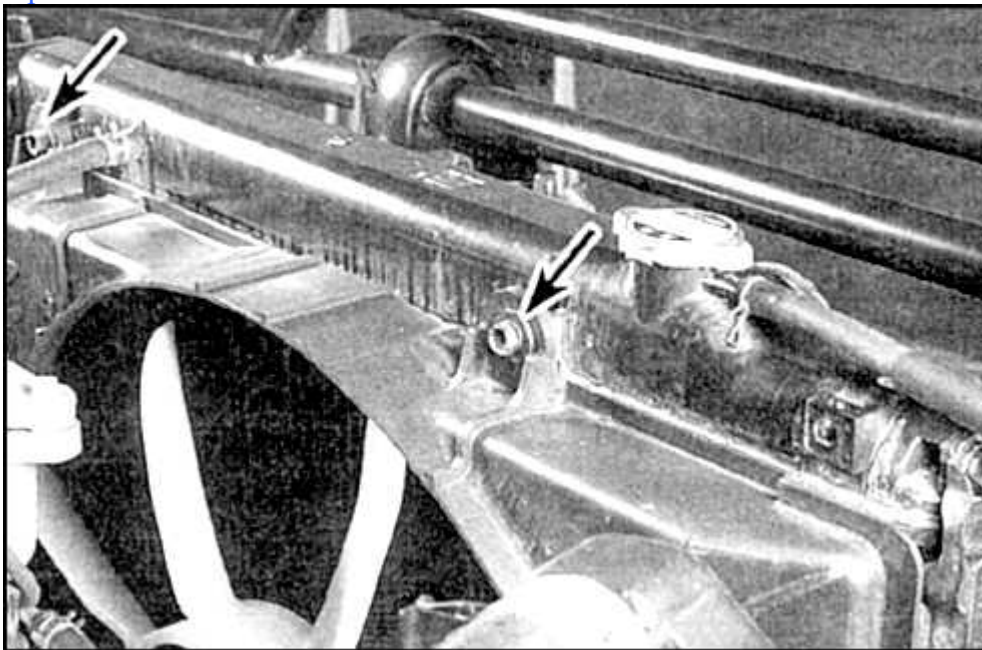

2. Substitute sleeves when it detects a leak. 2. Replace sleeves when it detects a leak.

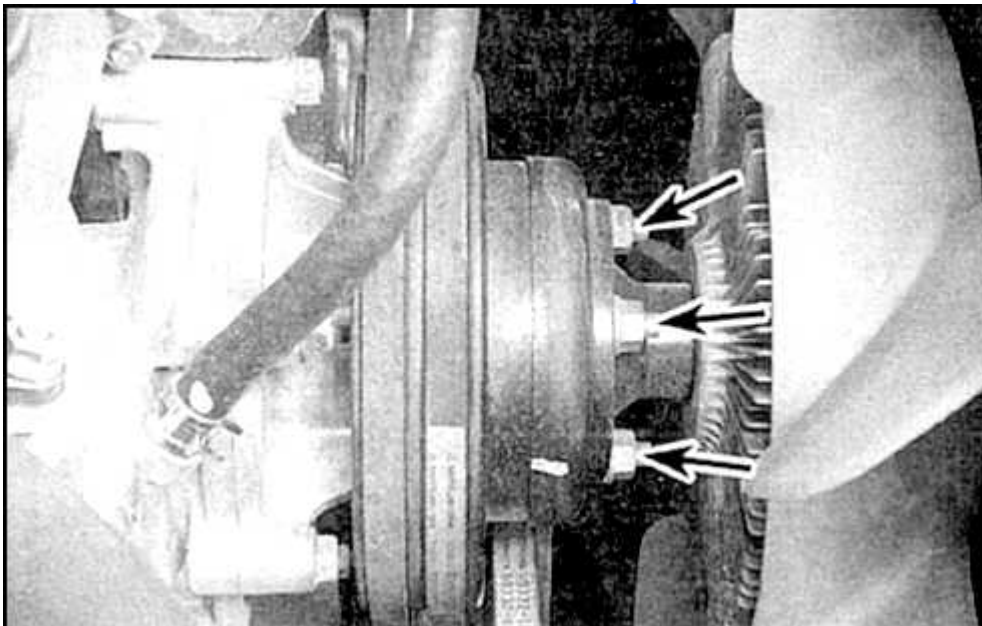

3. Mufta be replaced when detecting axial impeller play on the shaft.

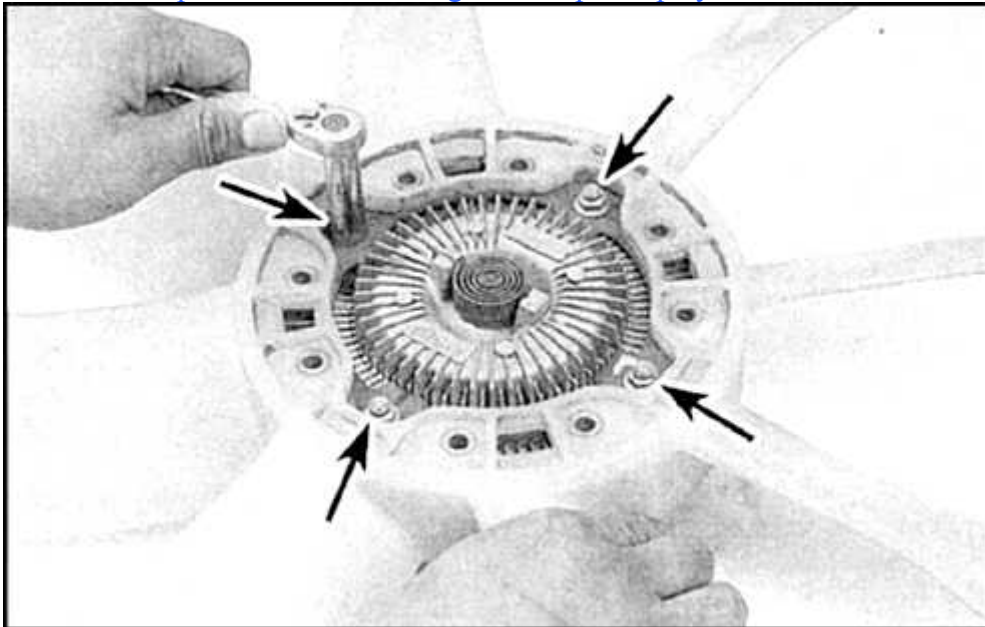

4. Check the resistance yield impeller. 4. check the resistance yield impeller.

5. If the impeller rotates freely, or too hard, it should be replaced.

6. At progretom engine permissible small increase resistance to the rotation of the impeller. 6. Na progretom engine permissible small increase resistance to the rotation of the impeller.

Withdrawal Withdrawal

5. Remove the pump pulleys and disconnect hoses. 5. Remove the pump pulleys and disconnect hoses.

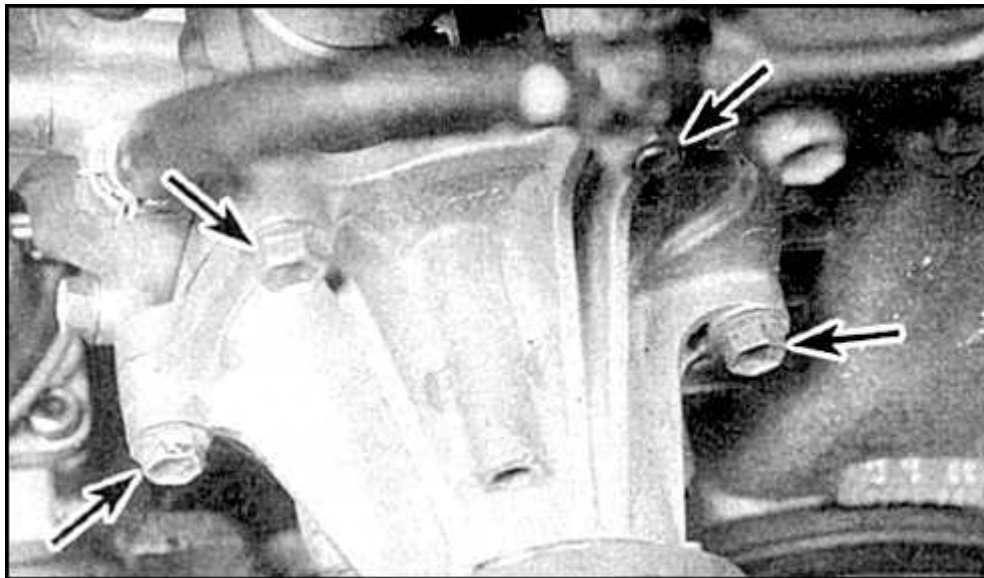

6. Reject bolts (indicated by arrows) and remove the pump. 6. Otvornite bolts (indicated by arrows) and remove the pump.

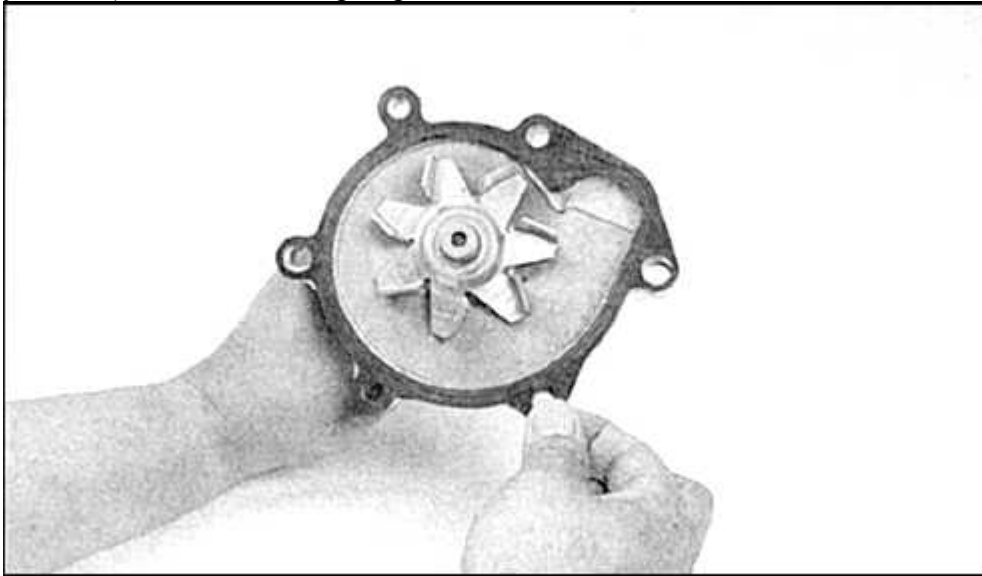

7. Dismantle the pump and replace gaskets. 7. Dismantle pump and replace gaskets.

8. Carefully clear wooden plane from the remnants of a cover gaskets.

9. Installation is performed in reverse order. 9. Installation is performed in reverse order.

10. Bolts tighten with a given moment. 10. Bolts tighten with a given moment.

4.8. Temperature sensor fluid Temperature sensor fluid GENERAL BACKGROUND

Location temperature sensor on the engine 3F-E Location temperature sensor on the engine E-3F

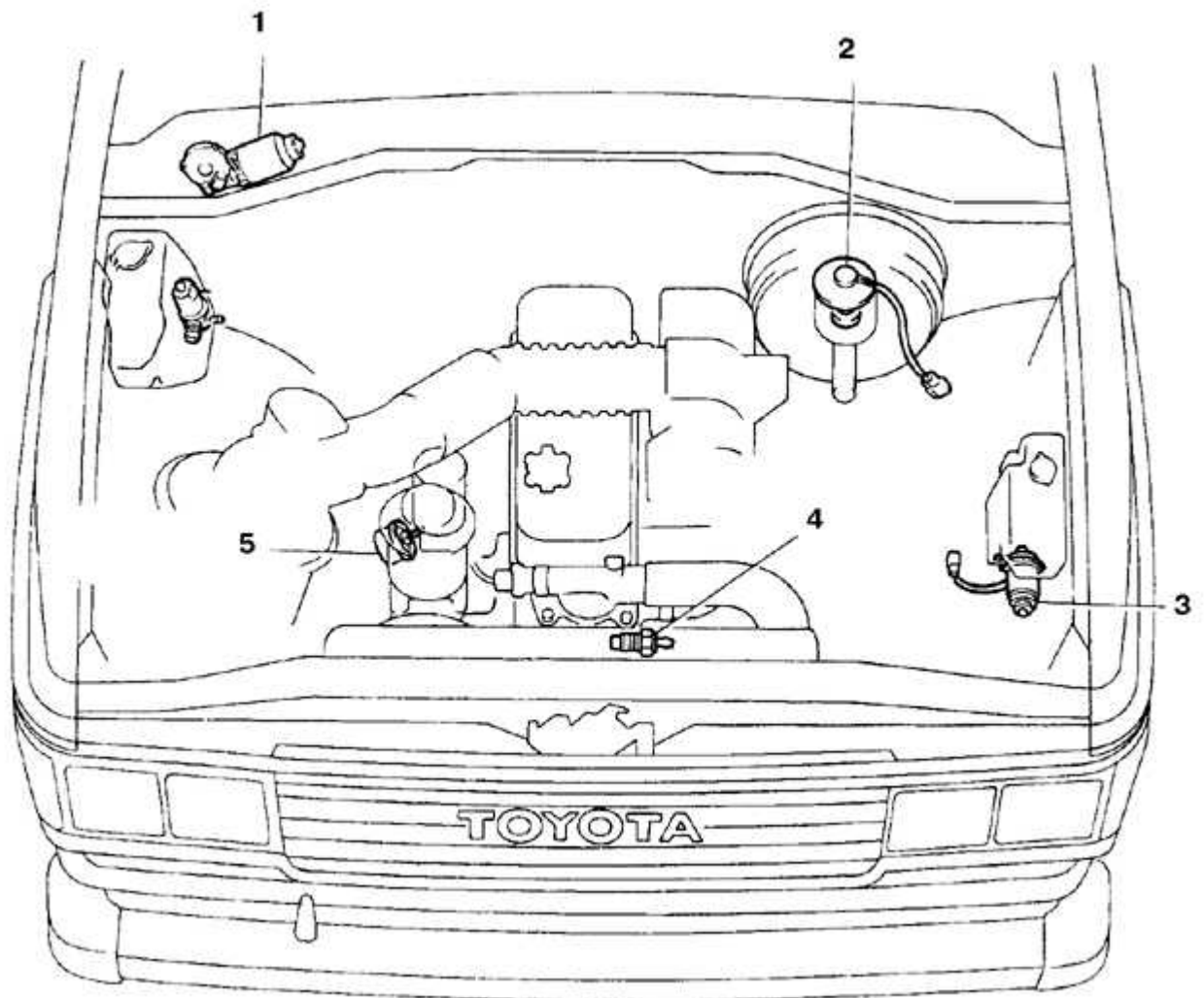

1. Electric Windshield Wiper Motor
2. Brake fluid level sensor Brake fluid level sensor
3. Motor cleaners headlamps Motor cleaners headlamps 4. Datchki temperature liquid
Datchki temperature liquids
5. Pressure sensor Oil Oil pressure sensor

Location temperature sensor on the engine 1FZ-FE

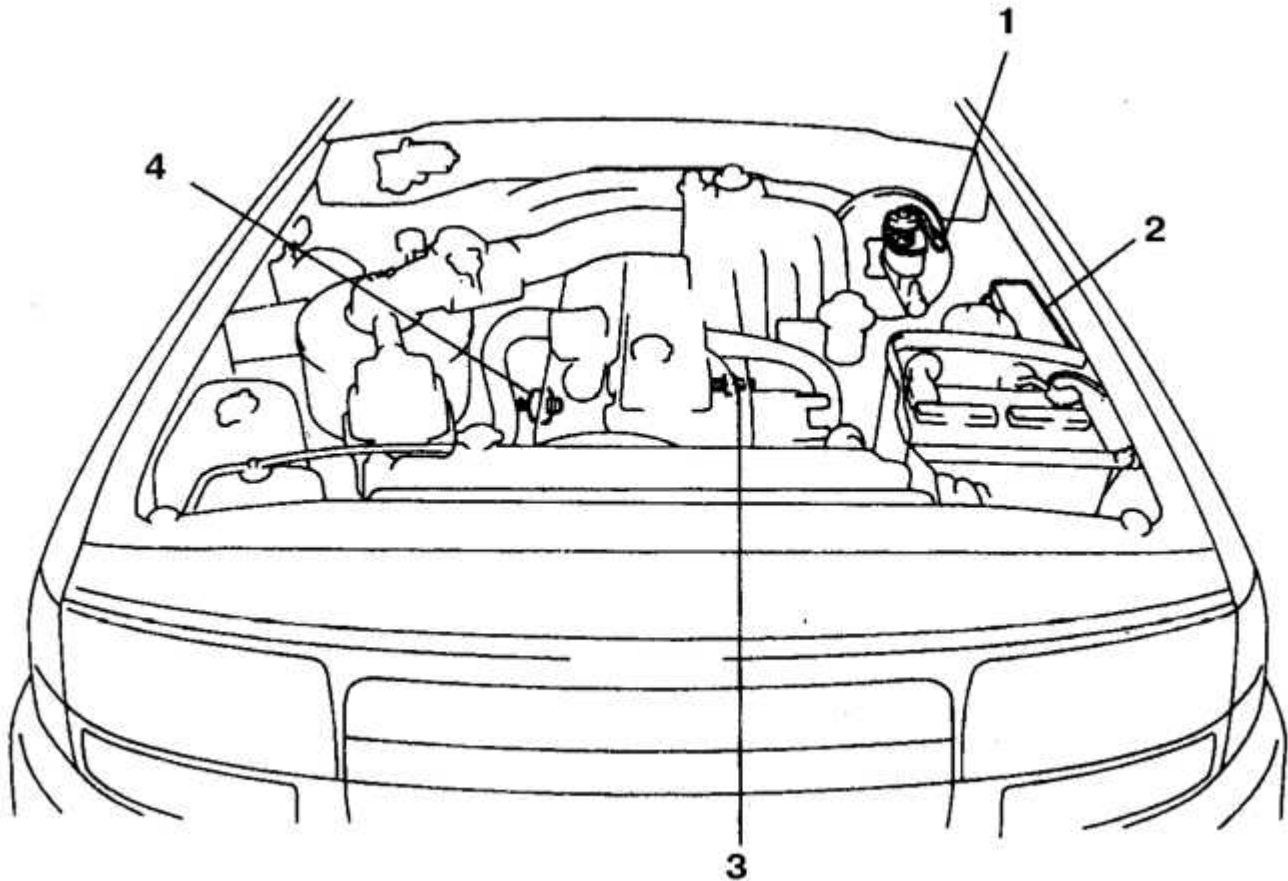

1. Brake fluid level sensor Brake fluid level sensor
2. Block Block Relays relays 3. Temperature sensor fluid Temperature sensor fluid
4. Pressure sensor Oil Oil pressure sensor

Checking Checking

IMPLEMENT THE ORDER OF ORDER OF PERFORMING

1. If the temperature does not register, then check the fuses. 1. If the temperature does not register, then check the fuses.
2. If the probe shows the status of "Hot" ("hot") immediately after a cold engine start, then disconnect the wire from the sensor. 2. If the sensor shows the status of "Hot" ("hot") immediately after a cold engine start, then disconnect the wire from the sensor.
3. If the testimony is falling, the sensor is replaced. 3. falls If the testimony, the sensor is replaced.
4. If the testimony is inflated, the reasons might be a lot of focus on the sensor wires, or defective indicator. 4. If the testimony is inflated, the reasons might be a lot of focus on the sensor wires, or defective indicator. At E-3F engine sensor is located under the thermostat. At E-3F engine sensor is located under the thermostat.
5. If the temperature sensor ceases to show up after the full power (after approximately 10 minutes after launch), and fuses serviced, it shall proceed as follows. 5. If the temperature sensor ceases to show up after the full power (after approximately 10 minutes after launch), and fuses serviced, it shall proceed as follows.
6. Stop the engine, disconnect the wire from the sensor wires and finishing touch on the well-wire sensor cleaned plot engine. 6. Stop the engine, disconnect the wire from the sensor wires and finishing touch on the well-wire sensor cleaned plot engine.
7. Turn on the ignition for a short time but did not start the engine. 7. Turn on the ignition for a short time but did not start the engine.
8. If the index now shows "Hot", the sensor is replaced. 8. pointer If now shows "Hot", the sensor is replaced.

9. If the probe were not available, the reason might be in the chain of cliffs, or failure of the sensor (see sub-section 11.1). 9. testimony sensor If not available, the reason might be in the chain of cliffs, or failure of the sensor (see sub-section 11.1).

Replacing Replacement

IMPLEMENT THE ORDER OF ORDER OF PERFORMING

1. Disconnect the wires from the sensor. 1. Disconnect the wires from the sensor.
2. Remove and wrap the new sensor, securely tighten. 2. Remove and wrap the new sensor, securely tighten. Sealant is not used. Sealant is not used.
3. Attach the wire. 3. Attach the wire.
4. Pour liquid, check the testimony of the sensor. 4. Pour liquid, check the testimony of the sensor.

4.16. Evaporator and expansion valve

Fixing cars evaporator to the series 60, 62

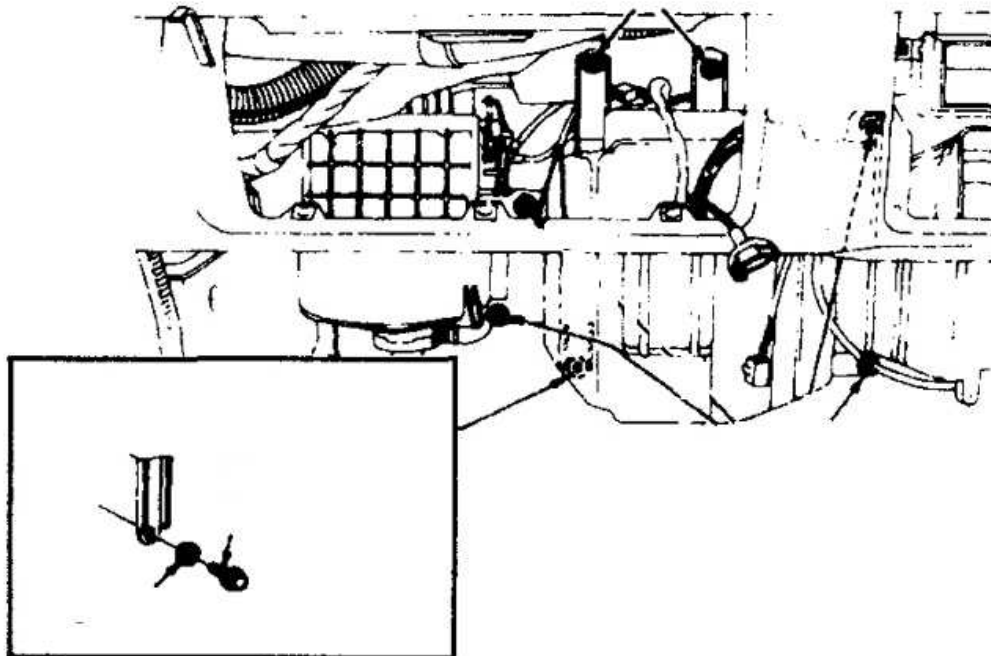

Fixing evaporator to avtomobilh Series 80

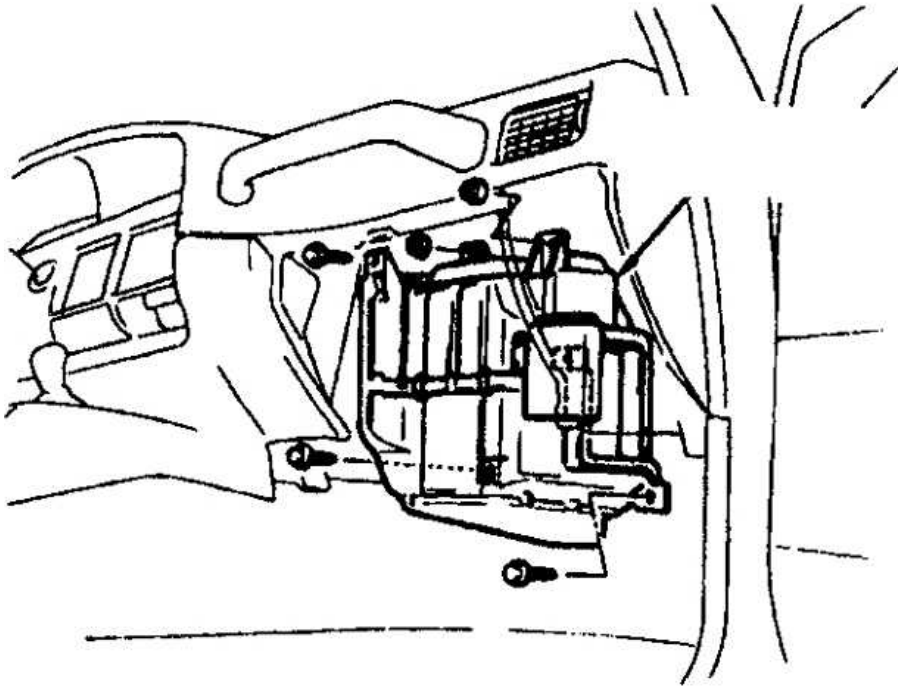

Details evaporator car series 60, 62

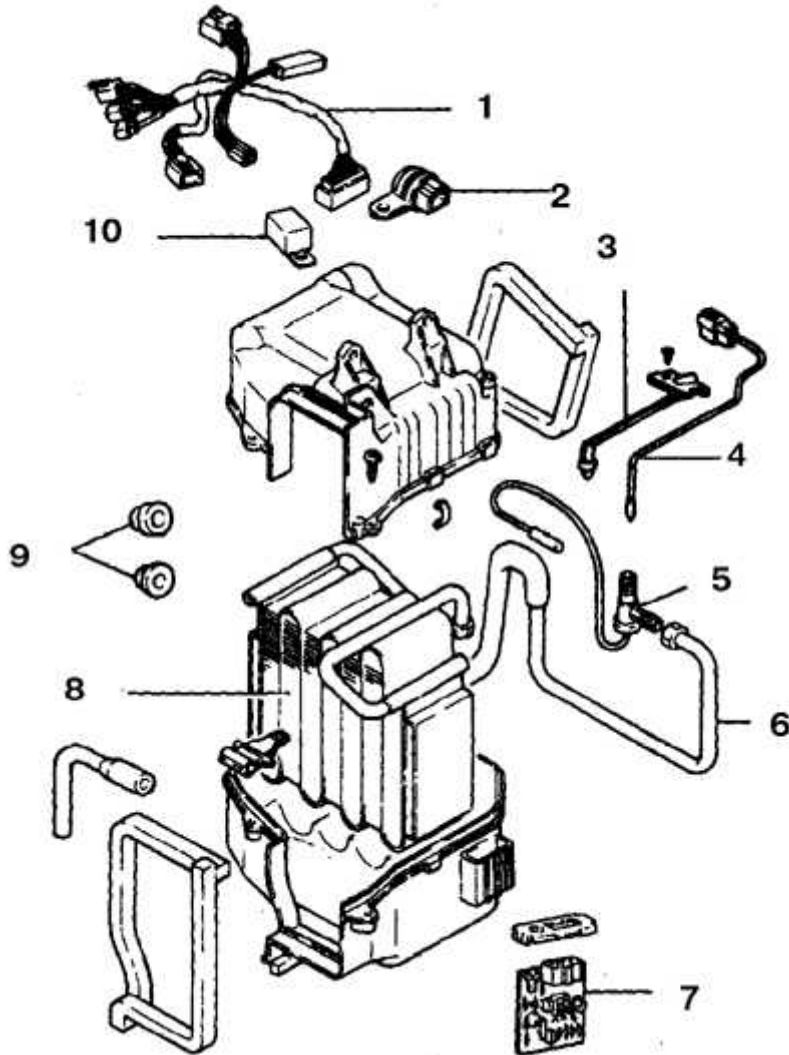

1. Wires Wires
2. Relay Relays sleeves sleeves
3. Holder Holder
4. Thermistor Thermistor
5. Expansion valve Expansion valve 6. The tube containing a liquid refrigerant The tube containing a liquid refrigerant
7. Amplifier Amplifier
8. Evaporator Evaporator
9. Transverse seal Transverse seal
10. Relays rear of the passenger compartment air conditioning Relays conditioning rear of the passenger compartment

Details evaporator Car Series 80

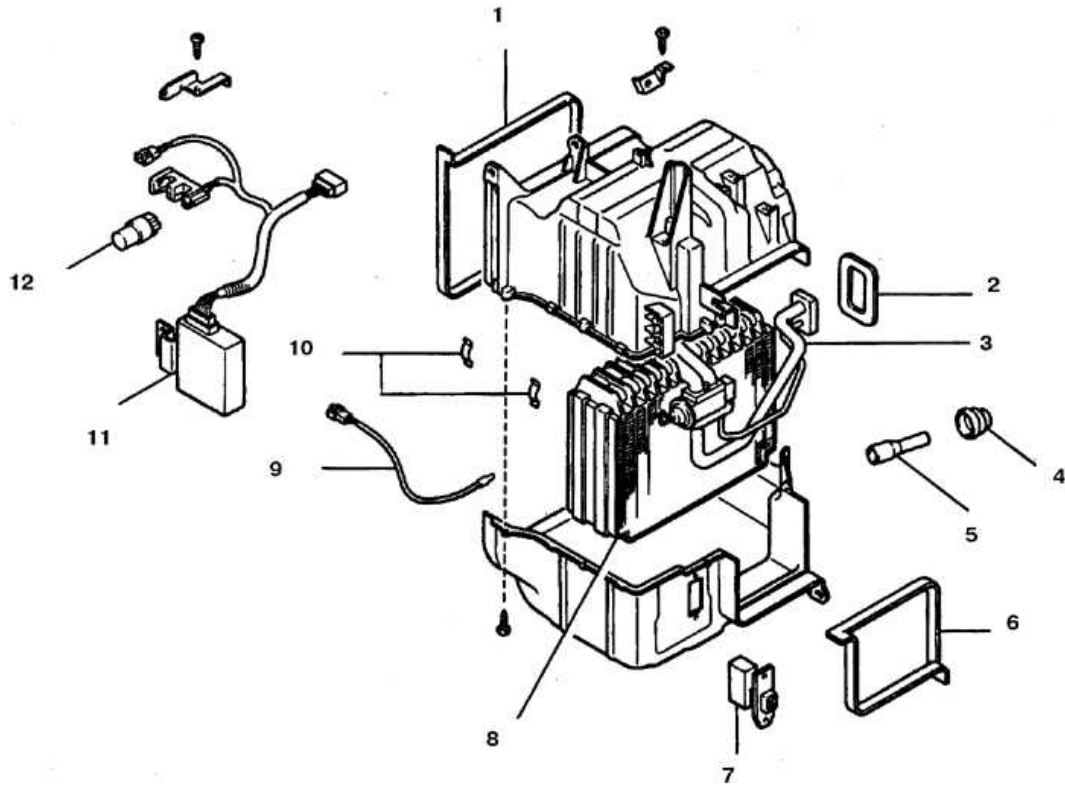

- 1, 2, 6. Seal seal
3. Expansion valve Expansion valve
4. Transverse compactors Transverse compactors
5. Drain hose discharge hose
7. Resistor resistor 8. Evaporator Evaporator
9. Thermistor Thermistor
10. Scoba Scoba
11. Amplifier Amplifier
12. Otsechnoe relay Otsechnoe relay

IMPLEMENT THE ORDER OF ORDER OF PERFORMING

1. Razgermetiziruyte air conditioning refrigerant car wash and remove. 1. Razgermetiziruyte conditioner refrigerant, and remove the car wash.

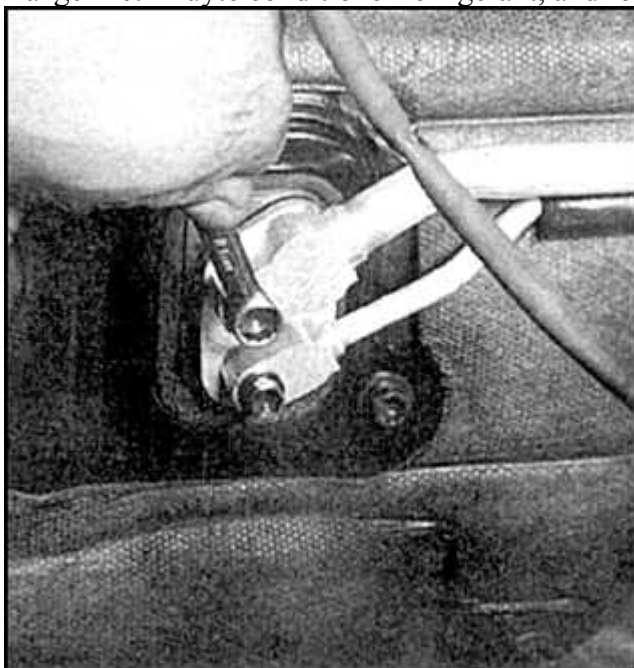

2. Remove the glove box.
3. Disconnect tube conditioner bulkhead at the engine compartment.
3. Disconnect tube conditioner on the engine compartment bulkhead. Otvorachivayte connections, keeping a key part of the Response to the tube does not collapse. Otvorachivayte connections, keeping a key part of the Response to the tube does not collapse.
4. For cars with an engine 1FZ-FE un-processor unit. 4. Motor vehicles with engine 1FZ-FE un-processor unit.
5. Reject fastening nuts and bolts and remove the evaporator. 5. Otvornite fastening nuts and bolts and remove the evaporator.
6. Set evaporator on the table, reject screws, un-latch, uncheck the upper and lower shells dostante evaporator and the evaporator. 6. evaporator Set on the table, reject screws, un-latch, uncheck the upper and lower shells dostante evaporator and the evaporator.
7. Get the evaporator thermistor, reject expansion valve mounting screws and two short tubes, and the filing of the disqualification of the coolant (see Fig. Bolts mounting the condenser). 7. Obtain from the evaporator thermistor, reject expansion valve mounting screws and two short tubes, and the filing of the disqualification of the coolant (see Fig. Bolts mounting the condenser).
8. Clean evaporator special combs and Purge compressed air. 8. Clean evaporator special combs and Purge compressed air.
9. If a new evaporator, enter about 40 g of fresh oil, recommended for your air conditioning system. 9. If a new evaporator, enter about 40 g of fresh oil, recommended for your air conditioning system.
10. Next, the installation is performed in reverse order. 10. installation Then in the reverse order.
11. Replace gasket sealing ring and expansion valve. 11. Replace gasket sealing ring and expansion valve.
12. Put air conditioning refrigerant in the same workshop, which performed razgermetizatsiya and removing the coolant. 12. Zapravte conditioner refrigerant in the same workshop, which performed razgermetizatsiya and removing the coolant.

5.2. Engines with fuel injected Engines with injection GENERAL BACKGROUND

The composition of the fuel system includes: The composition of the fuel system includes:

- fuel tank - fuel tank;
- electric fuel pump (mounted inside the tank) - electric fuel pump (mounted inside the tank);
- Main relay system, the fuel injection pump and relays - Main relay system, the fuel injection pump and relays;
- jets - jets;
- fuel pressure regulator - fuel pressure regulator;
- air filter - air filter;
- Housing throttle valve. -- Housing throttle valve.

Cars 1988-92's. Cars 1988-92's. with E-3F engine equipped with electronic fuel injection (EFI system). with E-3F engine equipped with electronic fuel injection (EFI system).

Cars since 1993 with the 1FZ-FE engine equipped with an advanced direct injection system. Cars since 1993 with the 1FZ-FE engine equipped with an advanced direct injection system. Injection system in the later models of different regulatory systems few changes of pressure and control of air flow. Injection system in the later models of different regulatory systems few changes of pressure and control of air flow.

ELECTRONIC SYSTEM VPRYSKA FUEL ELECTRONIC SYSTEM VPRYSKA FUEL

In the direct injection system, fuel is introduced into each cylinder through the nozzle. In the direct injection system, fuel is introduced into each cylinder through the nozzle. The system manages injection processor unit (block ECM), which sets the pulse duration (of fuel), in response to signalya with various engine gauges. The system manages injection processor unit (block ECM), which sets the pulse duration (of fuel), in response to signalya with various engine gauges. The number of air in the fuel mixture is set throttle valve. The number of air in the fuel mixture is set throttle valve. Pressure fuel is regulated through a distribution vacuum valve (VSV-valve). Pressure fuel is regulated through a distribution vacuum valve (VSV-valve). At progretom valve engine reduces fuel pressure during startup and impoverishes mixture. At progretom valve engine reduces fuel pressure during startup and impoverishes mixture. At a late-model of governance VSV valve obespechivaetsyaprotsessornym stack, in the early models - a special control system commissioning warmed engine (System High Temperature Line-Up Pressure). At a late-model of governance VSV valve obespechivaetsyaprotsessornym stack, in the early models - a special control system commissioning warmed engine (System High Temperature Line-Up Pressure).

FUEL PUMP AND AXES FUEL PUMP AND AXES

Circulation elektronasosom fuel is a couple of steel pipes. Circulation elektronasosom fuel is a couple of steel pipes. Return isparivshegosya fuel tank system is provided through a separate tube capture. Return isparivshegosya fuel tank system is provided through a separate tube capture. The pump is triggered when strongholds impulses from the unit plugs in the processor unit. The pump is triggered when strongholds impulses from the unit plugs in the processor unit. In the absence of such pulses pump shuts off after 2-3 seconds. In the absence of such pulses pump shuts off after 2-3 seconds.

VYHLOPNAYA SYSTEM VYHLOPNAYA SYSTEM

The system includes an additional oxygen sensor and 3 - a converter component, which refers to a system of waste gas cleaning and cooling the exhaust pipe to reduce toxic emissions. The system includes an additional oxygen sensor and 3 - a converter component, which refers to a system of waste gas cleaning and cooling the exhaust pipe to reduce toxic emissions.

7.4.3.4. Blocking hub

BACKGROUND

Handmade hub with a lock

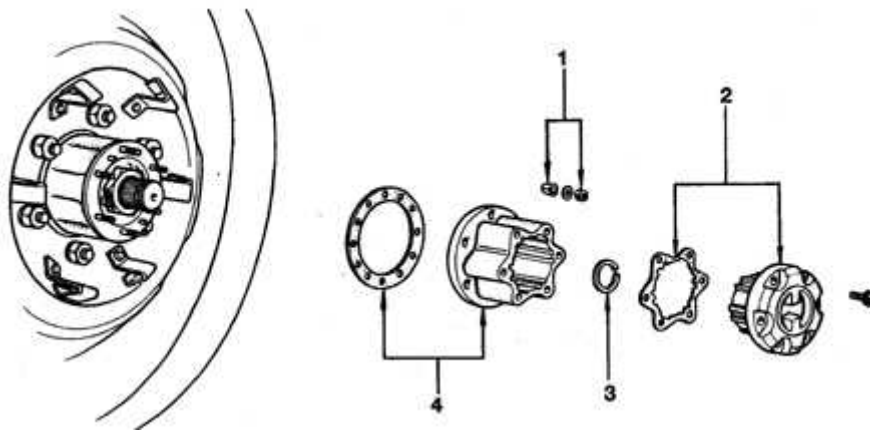

- | | |
|---------------------------------|---------------------------------|
| 1. Conical washer and nut | 3. Lock ring |
| 2. Kolpak hub and the laying of | 4. Corpus hub and the laying of |

Details clutch with manual hubs lockup

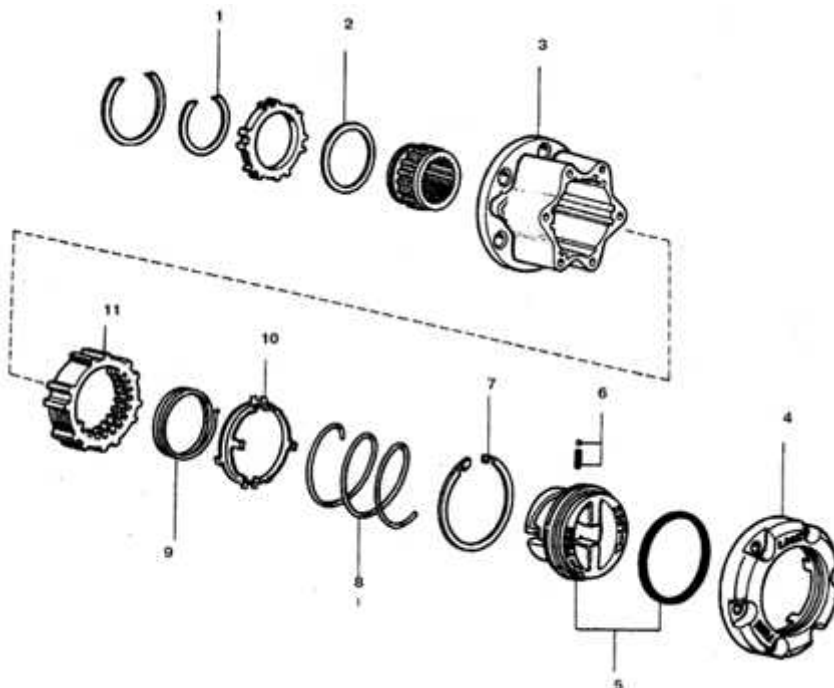

- | | |
|----------------------------|--------------------|
| 1, 7. Lock ring | 6. Ball and spring |
| 2. Gasket | 8, 9. Spring |
| 3. Corpus | 10. Ring latch |
| 4. Flange hub cap | 11. Mufta |
| 5. Handle and sealing ring | |

Removal and installation

STUPITSA X MANUAL BLOKIROVKOY

ORDER OF PERFORMING

1. Perestavte dome hub in the provision Free (hub unlocked).
2. Otvornite fastening bolts and remove the nakidnuyu along with the coupling nut.
3. Obtain lock ring.
4. Otvornite nut shell hub.
5. Latunnym loosening hammer and remove the conical washers.
6. Remove the hub.
7. If you want to further dismantling clutch hub for cleaning, then pay special attention to the details of the assembly sequence.
8. Clean all the details on one, without violating their order.
9. Sborku sleeves perform a reverse order of disassembly.
10. Compiling runs in the reverse order.
11. replace all gaskets and brush slots universal lubricant.
12. Translate handle the situation in the Free flange and set a cap so that the ears on the flange went notches in the hull.

SELF STUPITSA

ORDER OF PERFORMING



1. Remove dome.

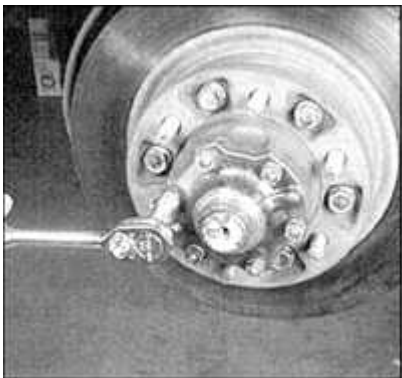

2. Otvornite mounting flange bolts.



3. Latunnym loosening hammer and remove the conical washers.

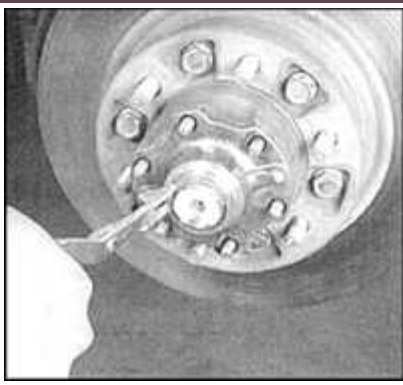

4. Obtain lock ring and remove the hub.

5. Compiling runs in the reverse order.

9.12. The pump power

Power steering engines to 2F and E-3F

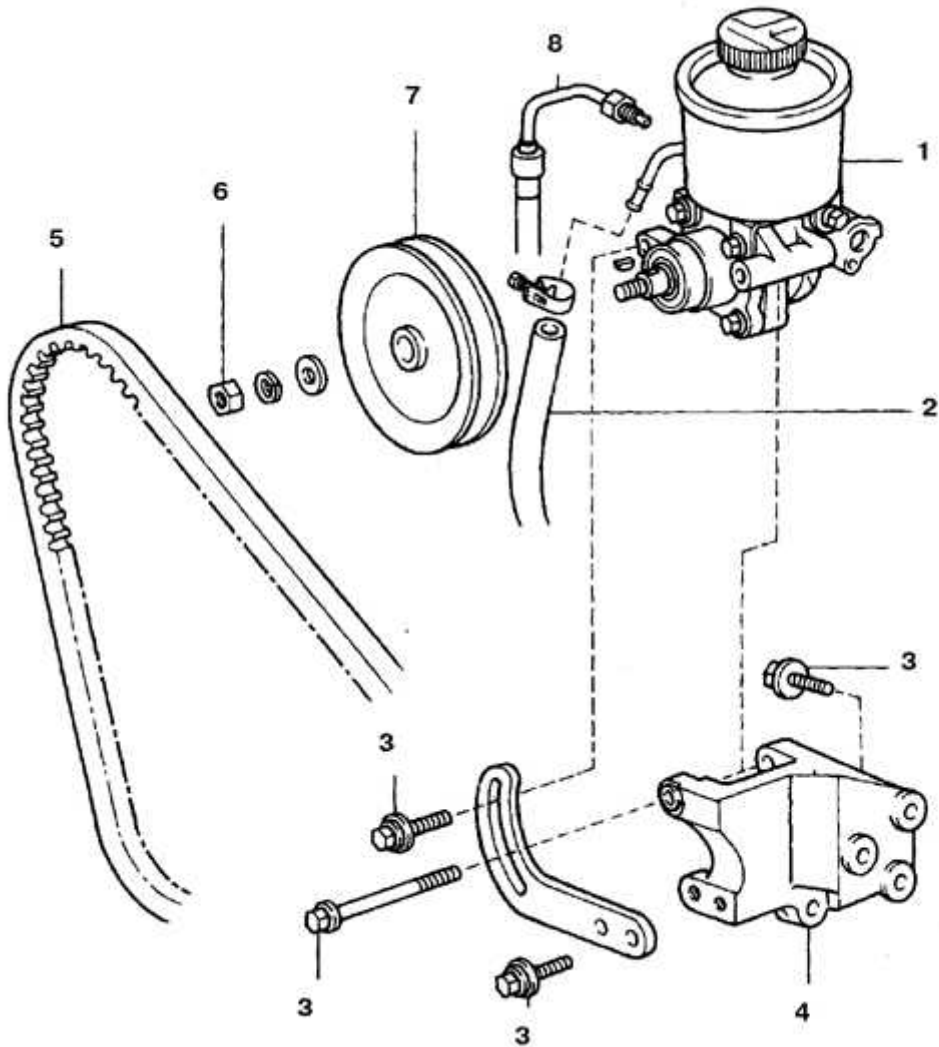

1. The pump pump
2. Hose Nozzle
3. Bolt Bolt
4. Bracket Bracket
5. Belt Belt
6. Nut Nut
7. Pulleys Pulley
8. Foam Foam

IMPLEMENT THE ORDER OF ORDER OF PERFORMING

1. Remove the drive belt (see 2.31). 1. Un-belt drive (see 2.31).

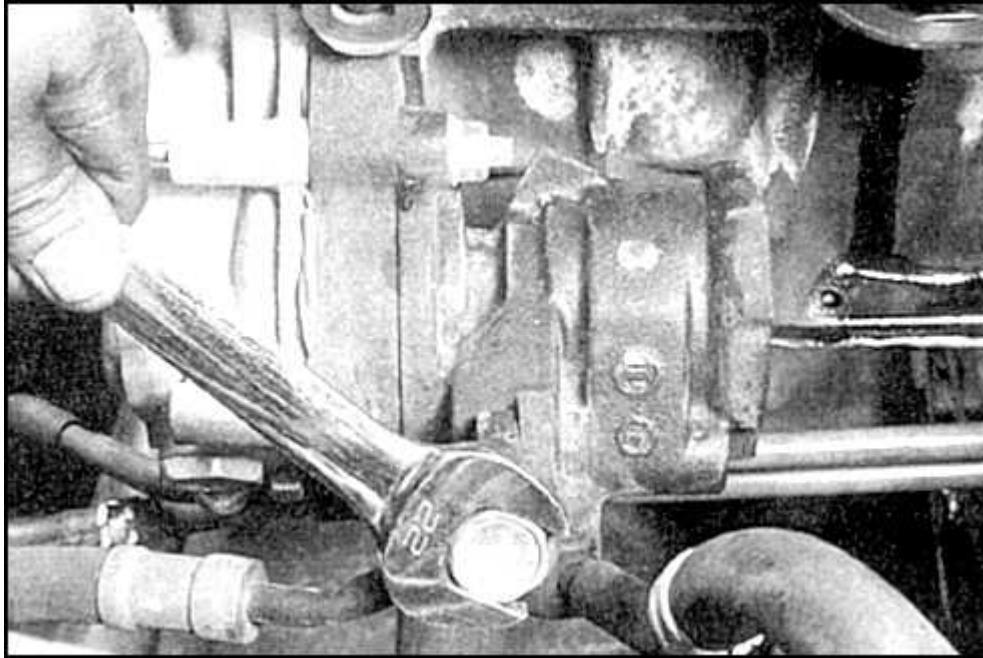

2.31. Belts drive

BACKGROUND

Typical signs of wear wedged belt

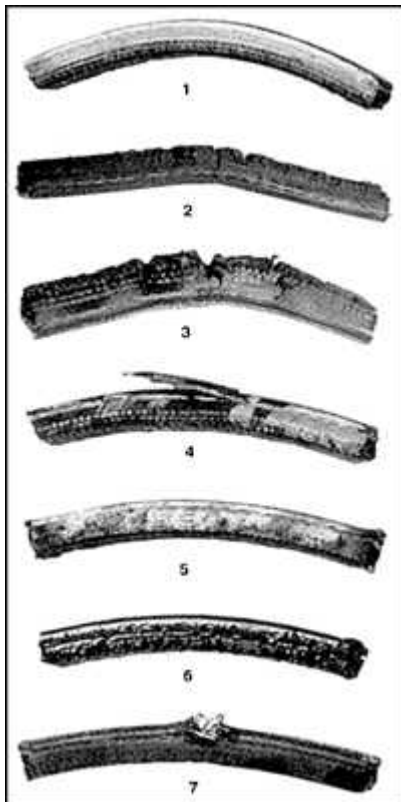

1. Slot on the sides
2. Carbonization
3. Cracked
4. Detached from the foundation
5. Waxed (glyantsevitost)
6. Falling oil
7. Laceration

Checking belt

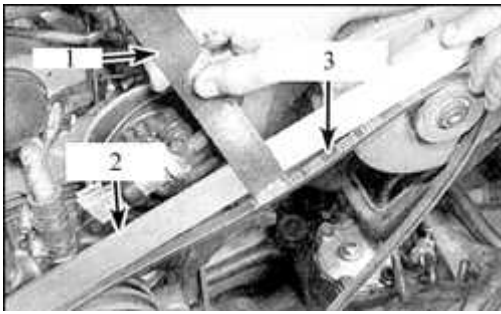

1. Ruler
2. Bar
3. Anticline

At engines used cuneiform drive belts. Because of the constant loads occur over time pulling their belts and condition deteriorates. Therefore, belts should be checked periodically.

Number belts installed in a car depends on the type of engine and a complete set of the car. The belts are used to drive the generator, coolant pump, air conditioner and power.

Checking

ORDER OF PERFORMING

1. Stop the engine and opened the hood, find the drive belts. Check belts, the presence of typical signs of wear, highlighting their flashlight. Check the belts on both sides.
2. check belt tension largest anticline midway between pulleys (see Fig. [Checking belt](#)). If the distance between the centers of pulleys 180-300 mm anticline should be 6.5 mm and the distance between the points at 300-400 mm anticline is to be a wedge to 13 mm and 6.5 mm belt to belt with a ribbed profile. The line should be perependikulyarna bar.

Adjust the tension

ORDER OF PERFORMING

1. on all vehicles to adjust the drive belt needs to be moved to Layout bracket.

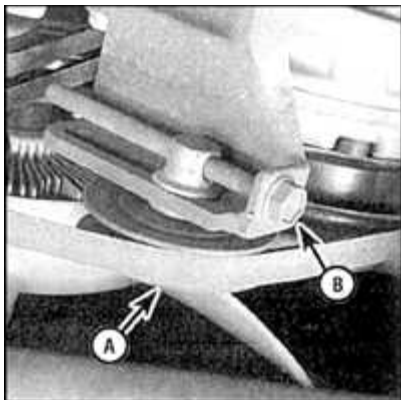

2. Belt is governed by two bolts - Axial (A) and (B) an adjustment. To adjust A loosening bolts and screws in advance, to shift the movie or pulleys rolling hub, drawing or weakening the belt.

3. adjustment check belt tension, if necessary, again loosening bolts and adjust the tension. After the adjustment tighten the screws.
4. Motor vehicles early releases rolling movie mortgage with an adjustment screw missing, movie (or pulleys), a subsidiary shifting lever (tire).

Replacing

ORDER OF PERFORMING

1. to replace belt preliminary follow the same procedure as for the adjustment, then uncheck the belt. All belts are encouraged to change at the same time. Before withdrawing specify each belt and the pulleys.
2. Buying a new belt compare with replaceable.

3. Adjust the belt tension.

2. Remove as much as possible from the vat of liquid, mute and disconnect hose and high-pressure tube. 2. Remove as much as possible from the vat of liquid, mute and disconnect hose and high-pressure tube.

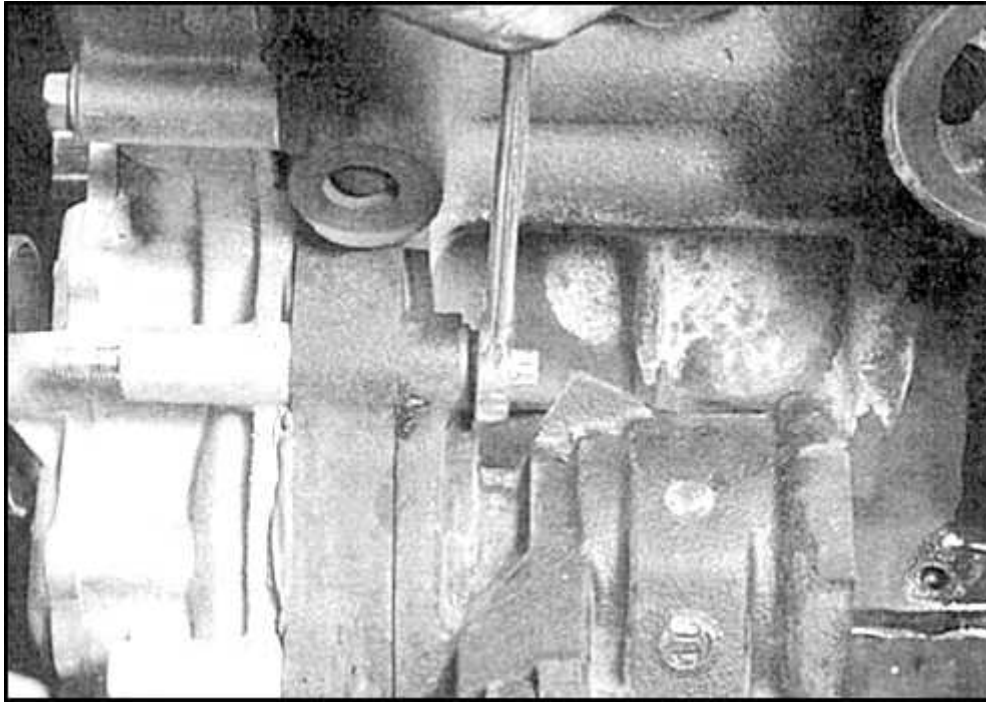

3. For cars with engines and 2F-3F E reject front fastening bolts pump. 3. Motor vehicles with engines and 2F-3F E reject front fastening bolts pump. For cars with an engine 1FZ-FE reject bolts fastening the pump to block cylinders. For cars with an engine 1FZ-FE reject bolts fastening the pump to block cylinders.

Install Installation

IMPLEMENT THE ORDER OF ORDER OF PERFORMING

1. Installation is performed in reverse order. 1. Installation is performed in reverse order.

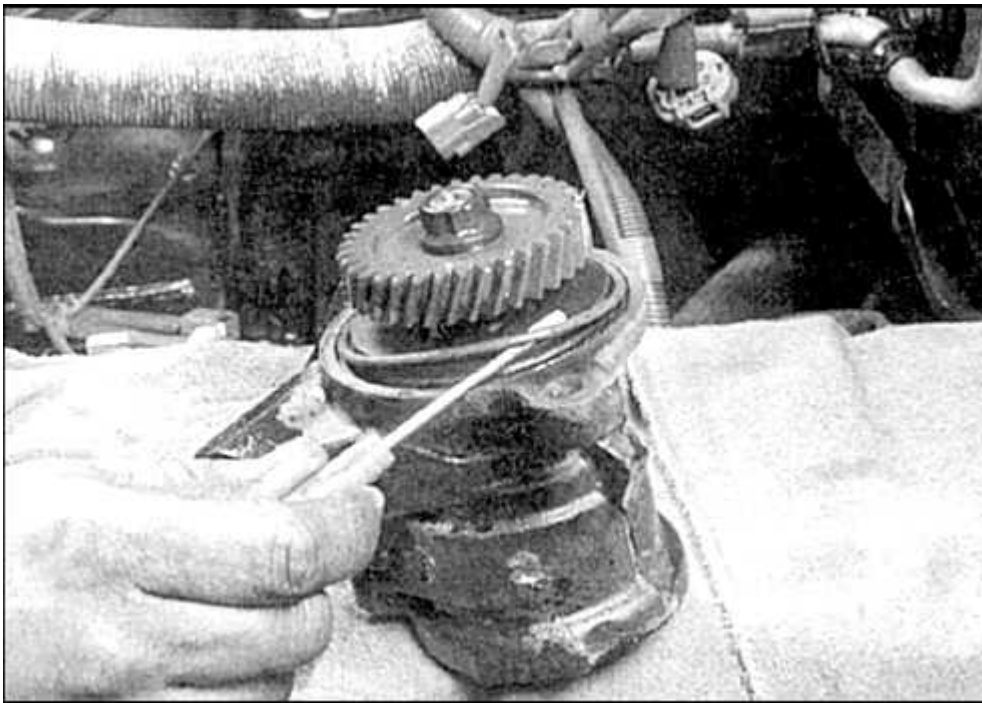

2. Tighten the nuts and bolts with a given moment. 2. Tighten the nuts and bolts with a given moment. For cars with an engine 1FZ-FE replace sealing ring pump. For cars with an engine 1FZ-FE replace sealing ring pump.

3. Remove air from the hydraulic (see 9.13). 3. Remove air from the hydraulic (see 9.13).

8.1. Technical Specifications

BACKGROUND

The gap between the amplifier push brake master cylinder and piston	
Disc brakes:	
-- lining thickness:	
• Standard	10.0
• limit	4.0
-- thickness hand brake linings:	
• Standard	4.0
• limit	1.0
-- run drive	not more than 0.15
-- limit the thickness of the disc	cast on disk
-- internal diameter disc brakes manually:	
• Standard	230
• limit	231
Drum brakes:	

-- lining thickness:	
• Standard	6.5
• limit	1.5
-- limiting diameter drum	cast on disk

Tightening moments (Nm)

Tie bolts supporta halves:	
-- front	110
-- Rear	78
Bolts front of the supporta	52
Bolts bracket rear supporta	92
Screw fastening the front brake disc to the hub:	
-- 1990 g.	41
-- 1991 g.	65
Bolt brake hose connections	27
Screw fastening wheel cylinder	8.4
Nuts to the master cylinder mounting vacuum-Amplifiers	10.8
Nuts mounting vacuum amplifier	10.8
Bolts mounting pressure regulator, automatic downloads of the car	10.8
Nuts wheels	110

8.6. Pads drum brakes

BACKGROUND

Installing hand pads A

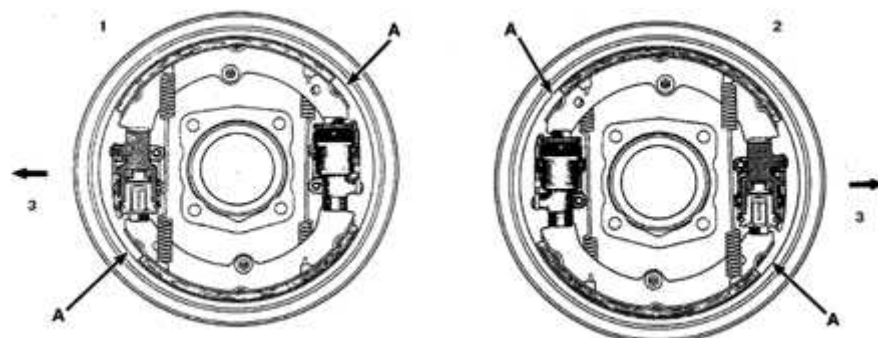

1. Left wheel
2. Right wheel

3. In front of the car

The situation pads after assembly

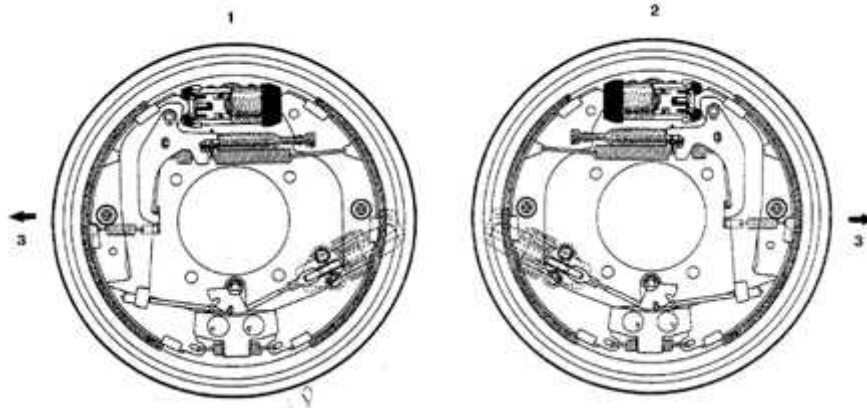

1. Left wheel
2. Right wheel

3. In front of the car

Warning

- ⓘ Pads are changing only in a package on one axis.

Along with changing shoes and tie springs, which are subjected to periodic thermal loads, gradually losing strength and do not provide sufficient diversion from the drum pad. As a result of hurt drum pad, causing premature wear and tear.

Replacing

ORDER OF PERFORMING

1. Release the wheel nuts, lift the back (or front) of the car.
2. Remove the wheel.
3. manual brake release.

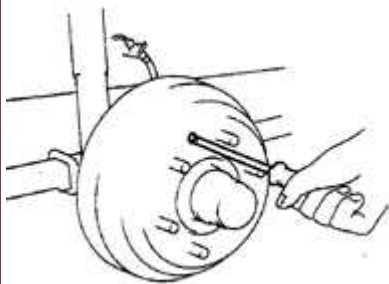

4. Designate situation drum reject screws (if required) and remove the drum.

5. defy If drum lifting, the fill between the flange bolts and the holes in the half-drum and the liquid seeps obstuchite drum inside the contour.

6. If this action is not a result that reduce pad.

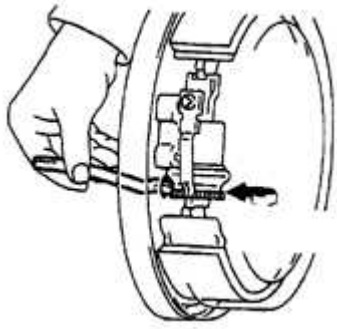

7. For this to brake pads with horizontal placement of the shield door dostante brakes and wheel cog wheel controller screwdriver.

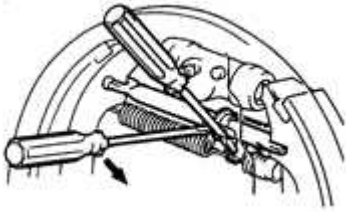

8. Na brakes with a vertical layout pad otvedite screwdriver with a narrow blade lever regulator of a cog wheel and wheel cog wheel controller other screwdriver.

The brake shoes with a horizontally located

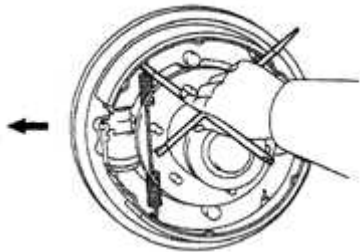

9. Remove styazhnuyu spring.

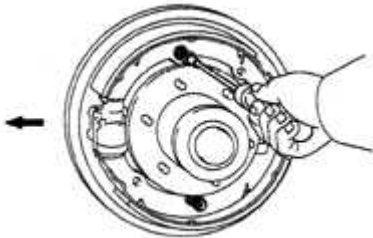

10. Remove the clips spring pad by clicking on the cup and turning 90 °.

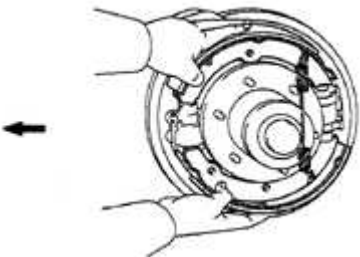

11. Remove the pads together with the lower spring.

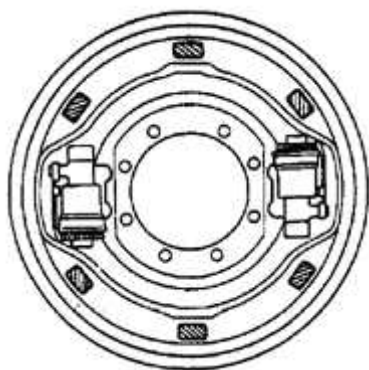

12. Smazhte rubbing surface of the pad shield refractory lubricant and install pad in reverse order.

13. pad A Party to set in accordance with the rice. [Installing A hand pads.](#)

The brake shoes with a vertically placed

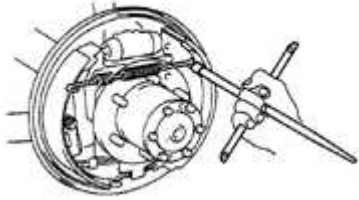

14. Remove the top springs.

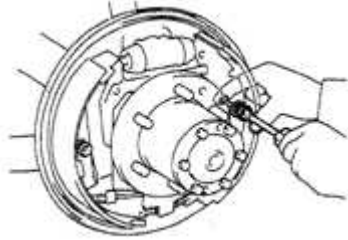

15. Remove bail spring by clicking on the cup and turning 90 °, and remove the back pad.

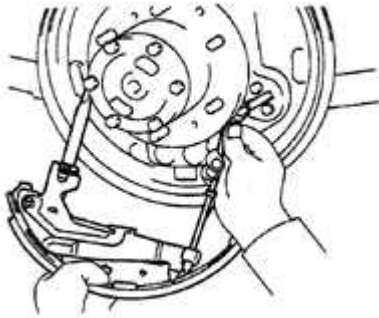

16. bail spring Disconnect and remove the front pad assemblies with the governor. Get a cable from the cable and hand brake lever.

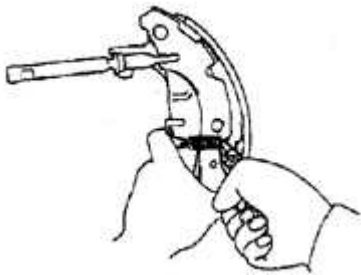

17. Remove the front pad with a spring lever regulator.

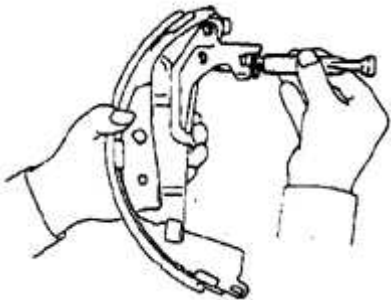

18. Remove the regulator.

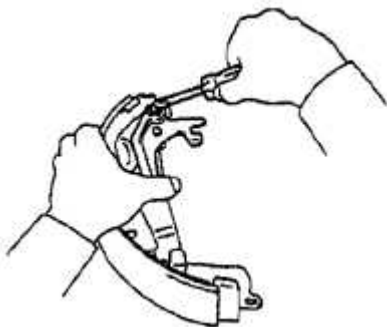

19. Remove washer and brake lever dostante regulator.

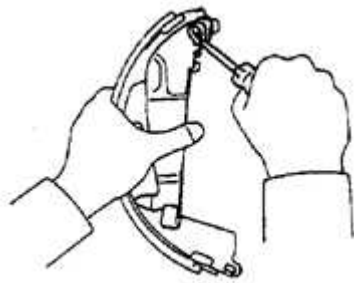

20. Remove the bracket and remove the hand brake lever.

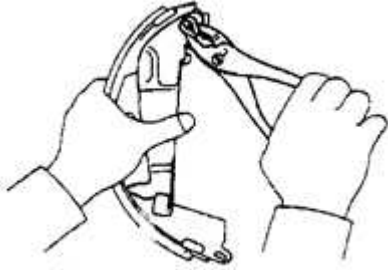

21. Set on the new front lever and hand brake pads and crimp bail. Install lever regulator and razreznuyu dog washer (washer and replace bracket).

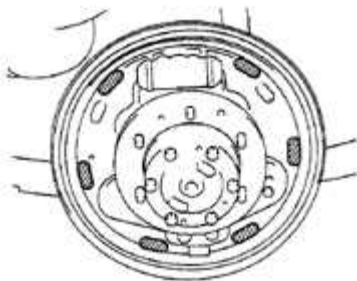

22. Smazhte rubbing surface of the pad shield refractory lubricant.



23. Smazhte details refractory lubricant regulator, the regulator screws in the hairpin spacer.

24. Set pad in reverse order.

25. situation pads after assembly dozhno look a certain way (see Fig. [situation pads after assembly](#)).

26. Clear drum and check the condition of the surface.

27. check ovalnost drum, with physical injuries protochite drum, small roughness sanded smooth rind.



28. protochki If, after an internal diameter of the drum is larger than the limit (shown in the drum), drum replace.

29. Set drum brakes and check adjustment.

30. If there is a gap between the drum and shoes too large, then uncheck the drum rotating wheel and hairpin razvedite pad until it touches the surface of the drum.

31. Slightly reduce pad that they do not zadevali for drum (checked audibly).

32. Set wheel and pull the car.

33. Take a few braking, moving forward and astern.

34. Before departure, check the brakes work.

9.13. Remove air from the hydraulic rudder

ORDER OF PERFORMING

- 1.** Remove air from the hydraulic rudder need for any disassembly line.
- 2.** Vystavte wheel, the situation straight away. Check the fluid level, as necessary to restore, doliv to tag on the Cold probe pans.
- 3.** Start the engine and the switch to work at fast idle. Check the fluid level, as necessary to restore, doliv to tag on the Cold probe pans.
- 4.** Provernite wheels on both sides until it stops, avoiding impact on the limiter. Check and re-establish the level of liquid.
- 5.** Return wheel, the situation straight away. A few minutes later the engine stop.
- 6.** check the fluid level, which for progretom engine should be at around Hot. If necessary add.

9. Pendants and steering

BACKGROUND

Details front suspension cars FJ60, 62

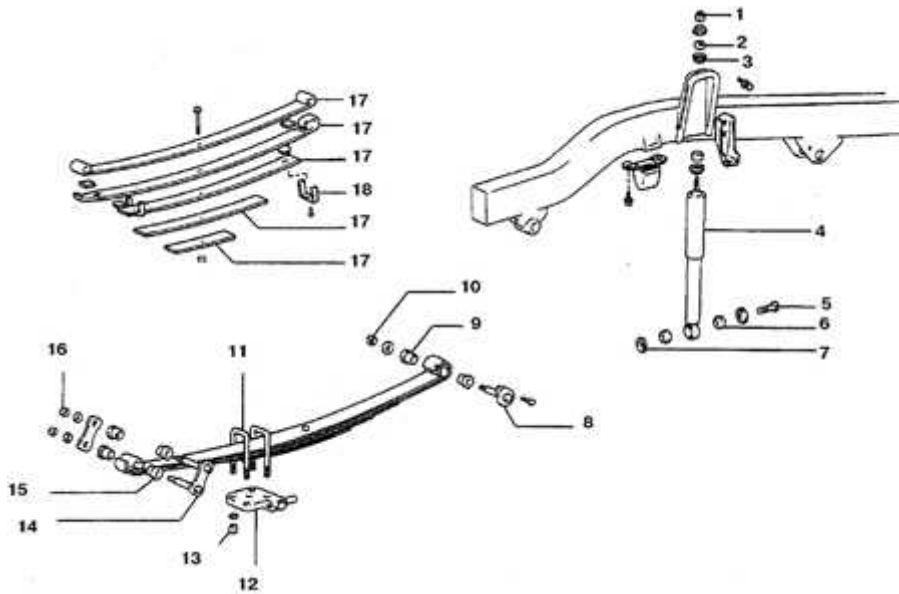

- | | |
|------------|-----------------------|
| 1. Nut | 10. Nut |
| 2. Buffer | 11. Rung ladder |
| 3. Cymbal | 12. Plastina |
| 4. Damper | 13. Nut |
| 5. Bolt | 14. Earrings springs |
| 6. Ferrule | 15. Ferrule |
| 7. Washer | 16. Nut |
| 8. Kingpin | 17. List springs N1-5 |
| 9. Ferrule | 18. Scoba |

Front suspension cars FJ80

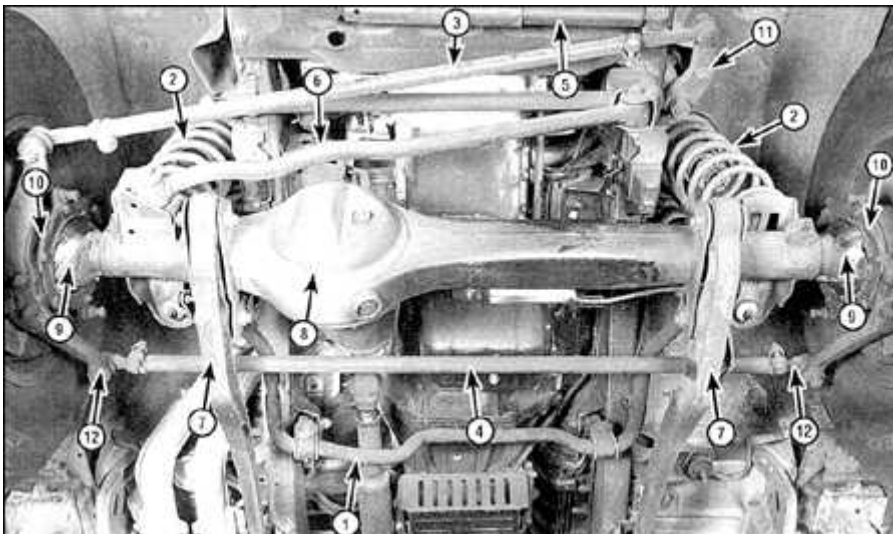

- | | |
|------------------------------------|------------------------------|
| 1. Stabilizer bar | 7. Lever |
| 2. Spring Suspension | 8. Gearbox front axle |
| 3. Lead steering traction | 9. Fork |
| 4. Managed steering traction | 10. Levers turning mechanism |
| 5. Pulsation fluctuations (damper) | 11. Sozka |
| 6. Horizontal strut | 12. An traction |

Rear suspension cars FJ80

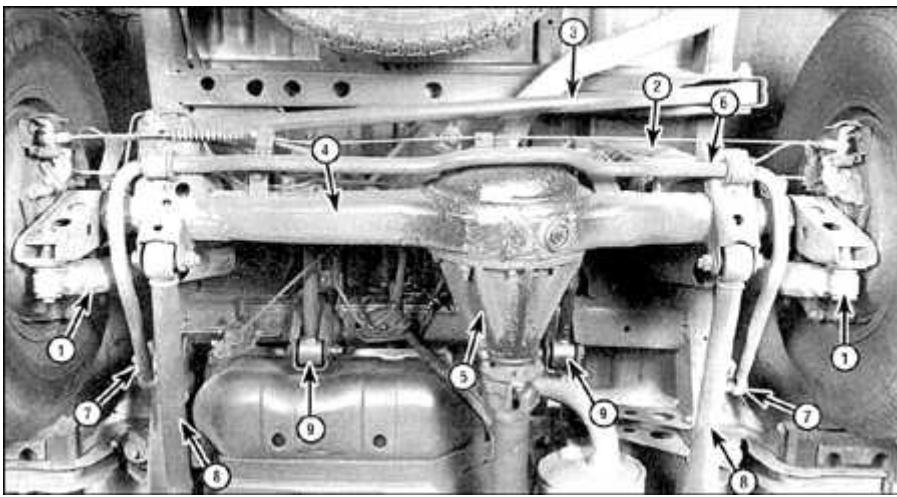

- | | |
|----------------------|----------------------|
| 1. Damper | 6. Stabilizer bar |
| 2. Spring Suspension | 7. Thrust stabilizer |
| 3. Horizontal strut | 8. The lower lever |
| 4. The front axle | 9. Upper lever |
| 5. Gearbox | |

Rear suspension cars FJ60, 62

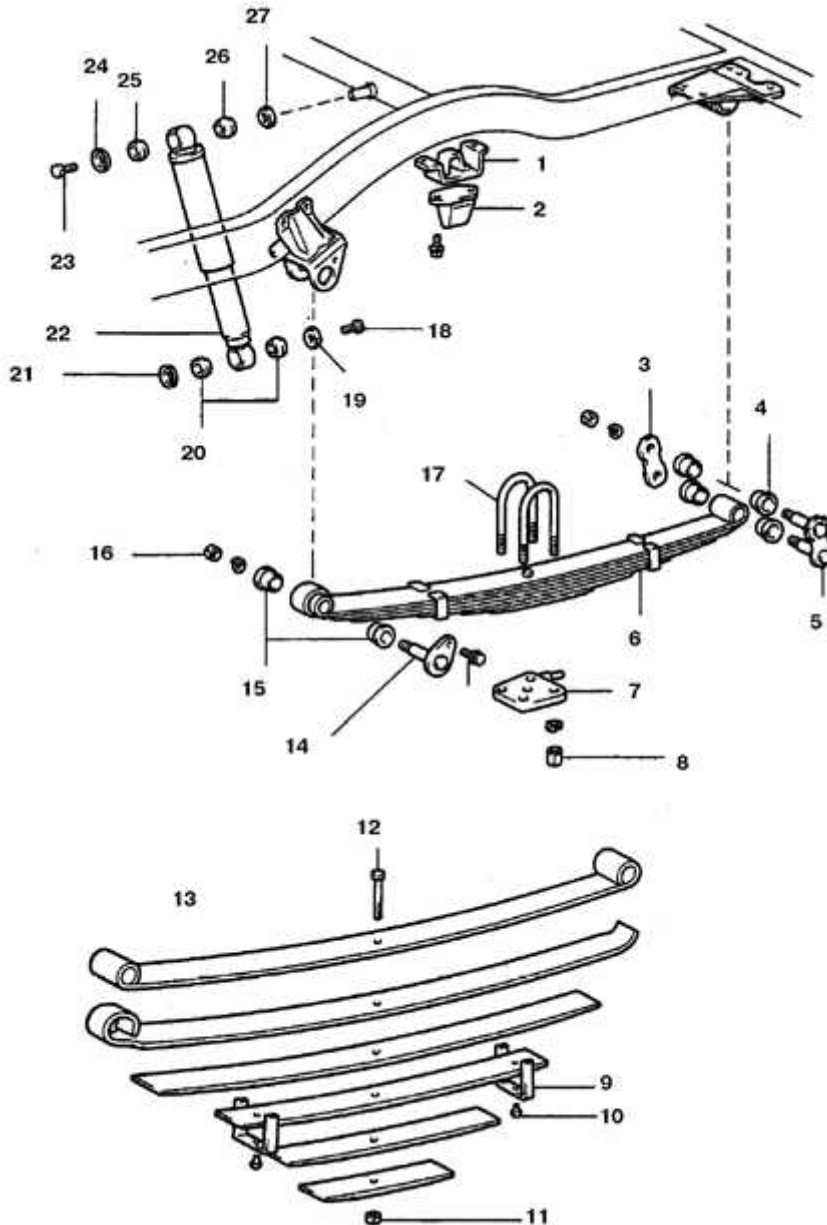

- | | |
|------------|--------------------------|
| 1. Bracket | 13. Left springs |
| 2. Buffer | 14. Axis bracket springs |

- | | |
|----------------------|---------------------|
| 3. Plastina earrings | 15. Bolt |
| 4. Ferrule | 16. Nut |
| 5. Earrings | 17. Rung ladder |
| 6. Springs | 18. Bolt |
| 7. Plastina | 19. Washer |
| 8. Nut | 20, 25, 26. Ferrule |
| 9. Scoba | 21. Washer |
| 10. Rivet | 22. Damper |
| 11. Nut | 23. Bolt |
| 12. Bolt | 24, 27. Washer |

SUSPENSION FRONT

Front suspension dependent, the suspension bridge is composed of rigid and elastic beam elements - springs and shock absorbers (on vehicles FJ60, 62), or springs and shock absorbers with transverse rods and levers (on vehicles FJ80). To reduce the inclination of the body when turning a stabilizer lateral stability. Reliance swivel pin are persistent radial bearings, sleeve to plug the holes in, welded to the front end of the bridge girders.

REAR SUSPENSION

Elastic elements of the rear suspension are springs and shock absorbers (on vehicles FJ60, 62), or springs and shock absorbers with transverse rods and levers (on vehicles FJ80). To reduce the inclination of the body with a turn in the rear suspension stabilizer also provides lateral stability.

STEERING

Cars equipped with hydraulic helm. The composition of the steering mechanism includes chervyachno-ball gearbox, traction and Vietnam (pendulum lever in this construction is absent). Between the middle and thrust bridge mounted gasitel fluctuations, which reduces unwanted "tinkling sound helm," that is, a small rebound helm of the situation, the appropriate turn of the wheels. Steering column broken in the accident.

Bolts and nuts steering control and suspension usually very difficult to turn. For this purpose affected corrosion compounds are encouraged to clean out brush and diluted liquid seeps. Sometimes screwed base can turn sharp blows on the core nuts. When otvorachivani not use extension cords with youngsters in order to avoid breakdowns Ratchet.

Using extremely burner flame is not recommended because of the high risk of fire. Tighten the key compounds dynamometer, which will facilitate the subsequent dismantling. In some anchorage for turning vijakoma slightly podtyanut recommend it.