

---

# STARTING

PRE-HEATING SYSTEM .....	ST-1
STARTER .....	ST-5
STARTER RELAY .....	ST-20

# PRE-HEATING SYSTEM COMPONENTS

ST0HH-02

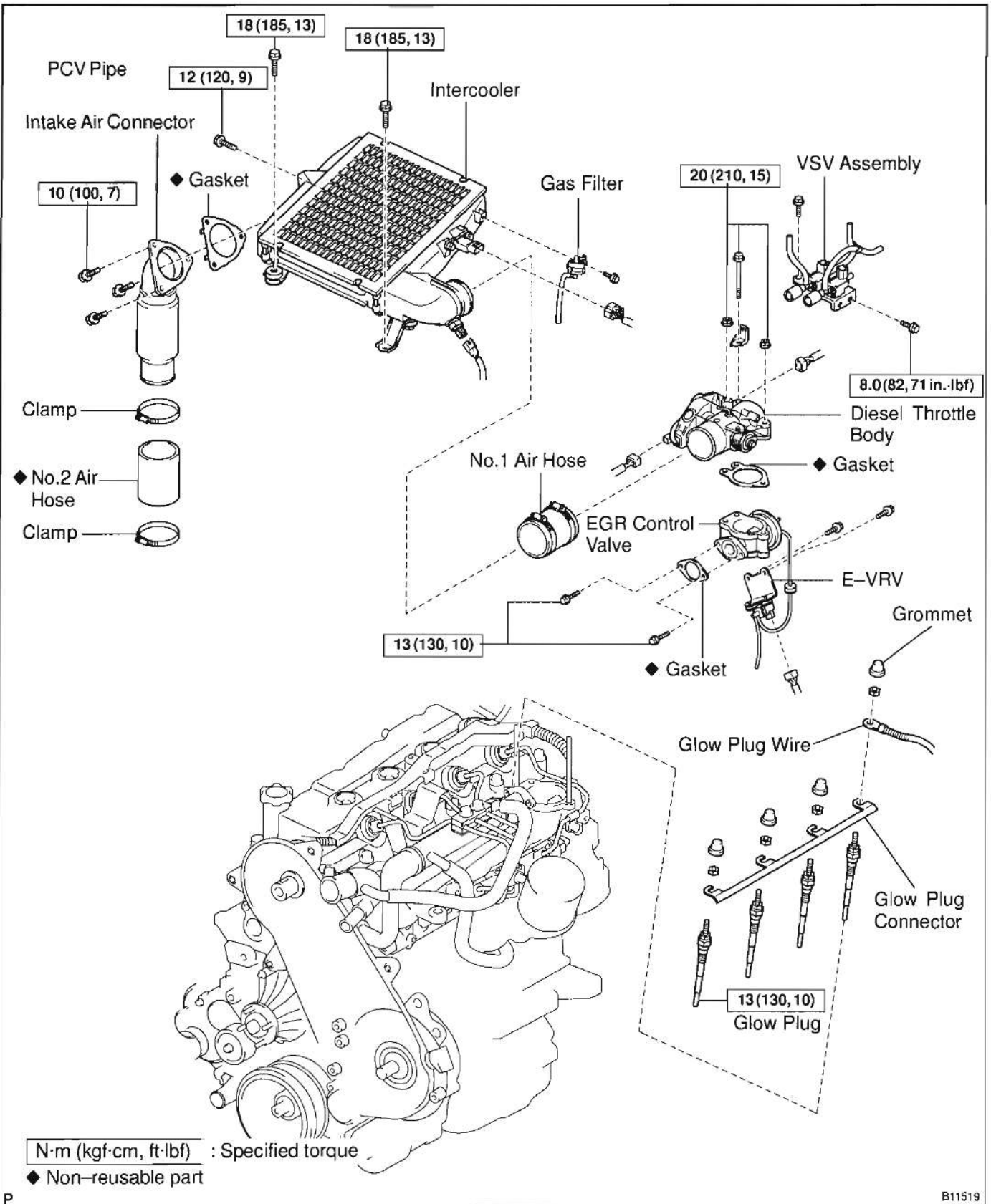

ST

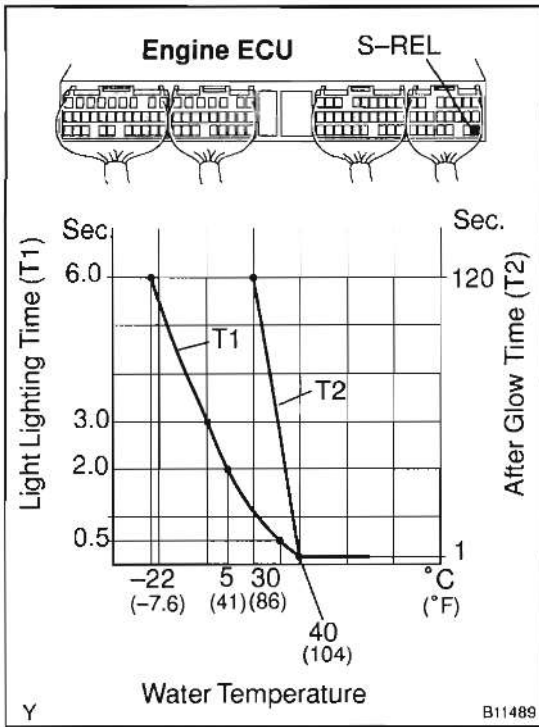

**INSPECTION**

**1. INSPECT LIGHTING TIME OF GLOW INDICATOR LIGHT**

Turn the ignition switch ON, and measure the lighting time.

**Light lighting time (T1): Refer to the chart graph**

**2. INSPECT AFTER GLOW TIME**

Turn the ignition switch to START, after the engine starts, measure the time when the battery voltage is applied to terminal S-REL of the engine ECU.

**After glow time (T2): Refer to the chart graph**

**3. INSPECT ENGINE ECU (See page DI-119)**

ST

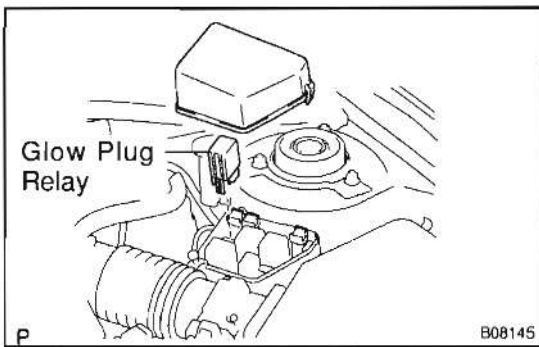

**4. INSPECT GLOW PLUG RELAY (Making: GLOW)**

- (a) Remove the relay box cover.
- (b) Remove the glow plug relay.

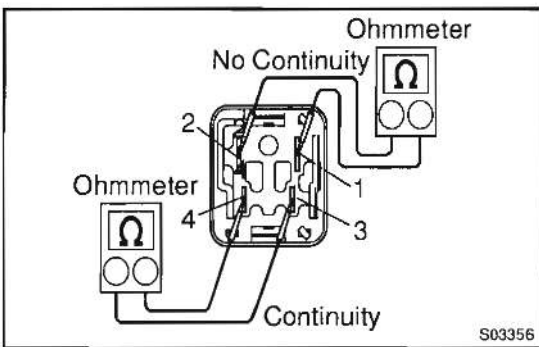

- (c) Inspect the glow plug relay continuity.
  - (1) Using an ohmmeter, check that there is no continuity between terminals 1 and 2.

If there is continuity, replace the relay.

- (2) Check that there is continuity between terminals 3 and 4.

If there is no continuity, replace the relay.

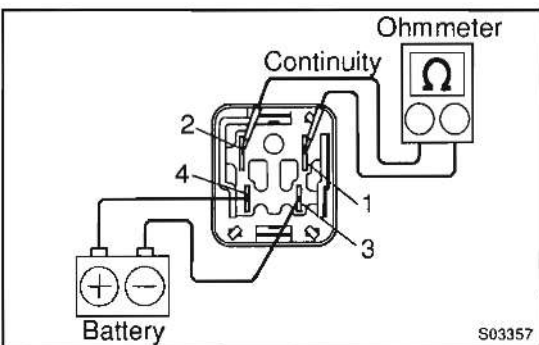

- (d) Inspect the glow plug relay operation.

- (1) Apply battery voltage across terminals 3 and 4.

- (2) Using an ohmmeter, check that there is continuity between terminals 1 and 2.

If there is no continuity, replace the relay.

- (e) Reinstall the glow plug relay.

- (f) Reinstall the relay box cover.

**5. INSPECT WATER TEMPERATURE SENSOR (See page ED-11)**

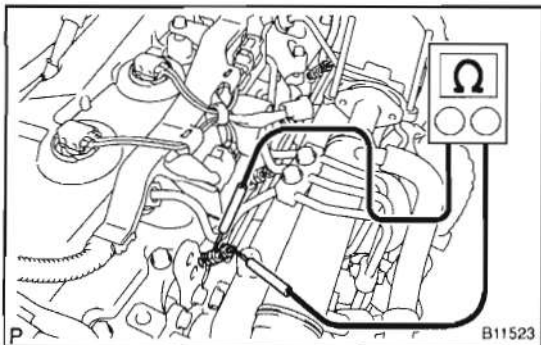

## 6. INSPECT GLOW PLUGS

Using an ohmmeter, check that there is continuity between the glow plug terminal and ground.

**Standard resistance: Approx. 0.72  $\Omega$  at 20°C (68°F)**

If there is no continuity, replace the glow plug.

**Torque: 13 N·m (130 kgf·cm, 10 ft·lbf)**

### NOTICE:

- Be careful not to damage the glow plug pipes as it could cause an open circuit or shorten life of the glow plugs.
- Avoid getting oil and gasoline on the glow plug when cleaning.
- During inspection, be sure to wipe any oil of the terminal and bakelite washer with a dry cloth.
- Be careful no to apply more than 11 V to the glow plug as it could cause an open circuit.

## REPLACEMENT

### REPLACE GLOW PLUGS

#### NOTICE:

The cylinder head and glow plug hole can seize up with carbon deposits. And if the glow plug is forcefully twisted when you remove it, the torsion can crack the material. So keep removal of the glow plugs to a minimum.

- (a) Remove the intercooler (See page EM-41).
- (b) Remove the EGR valve (See page EC-5)
- (c) Remove the glow plugs.
  - (1) Remove the 4 screw grommets from the glow plugs.
  - (2) Remove the ground wire from the glow plug.
  - (3) Remove the 4 nuts and glow plug connector from the glow plugs.
  - (4) Using a 12 mm deep socket wrench, remove the 4 glow plugs from the cylinder head.

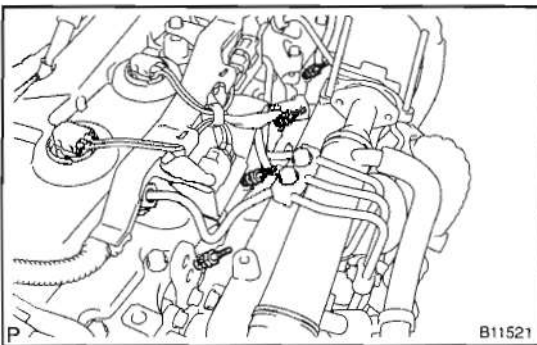
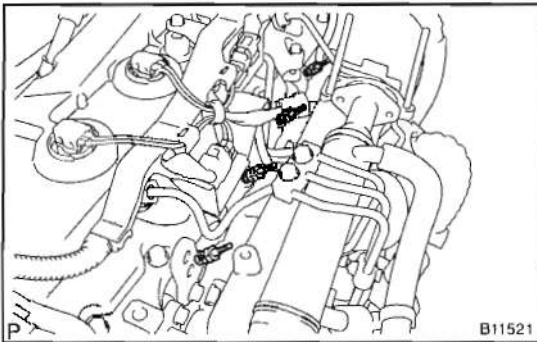
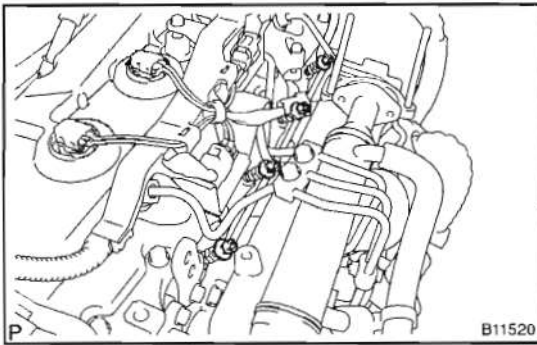

- (d) Install the glow plugs.
  - (1) Using a 12 mm deep socket wrench, install the 4 glow plugs to the cylinder head.

**Torque: 13 N·m (130 kgf·cm, 10 ft·lbf)**

  - (2) Install the glow plug wire to the glow plug.
  - (3) Install the glow plug connector to the glow plugs with the 4 nuts.

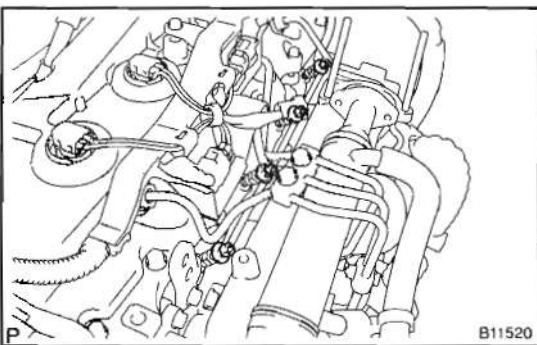

- (4) Install the 4 screw grommets to the glow plugs.
- (e) Install the EGR valve (See page EC-5).
- (f) Install the intercooler (See page EM-56).

# STARTER COMPONENTS

ST9BK-03

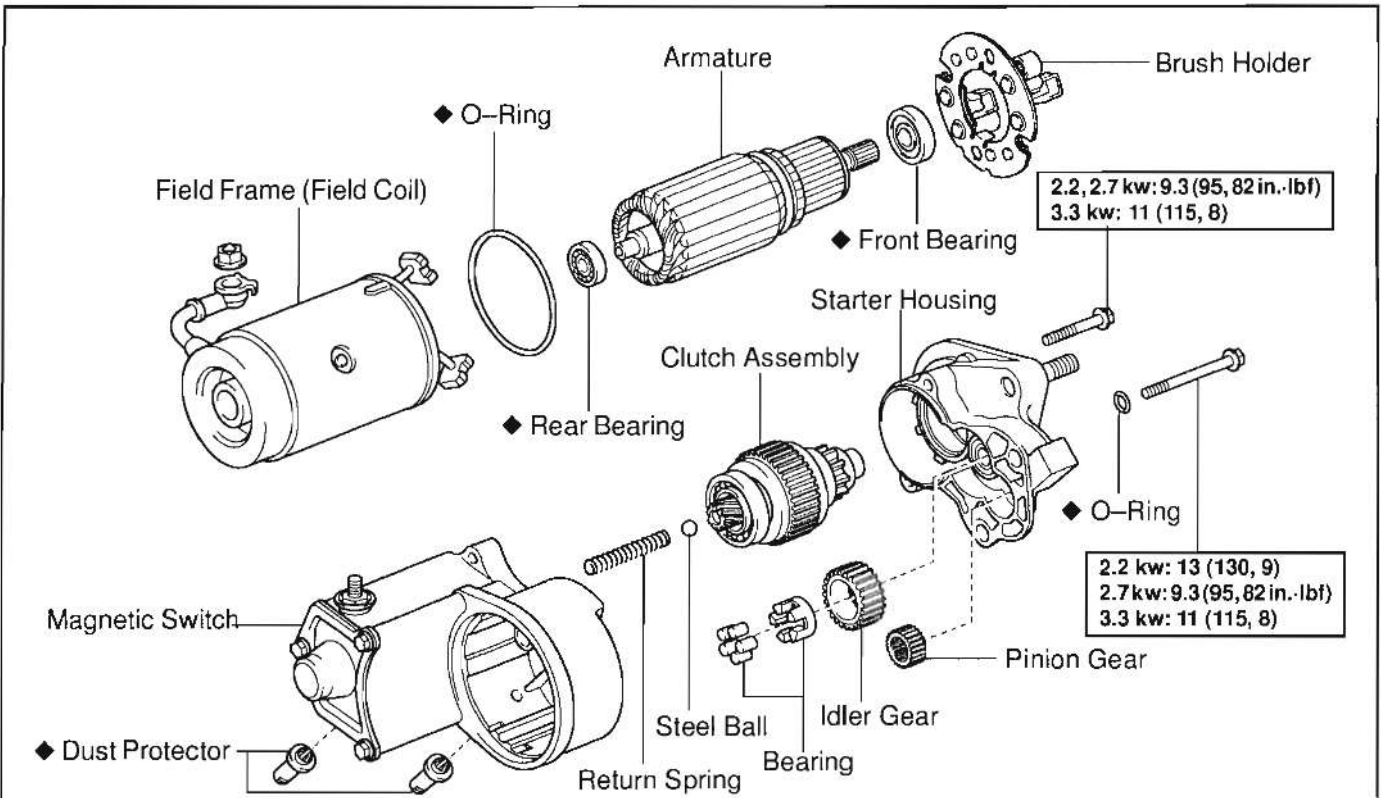

ST

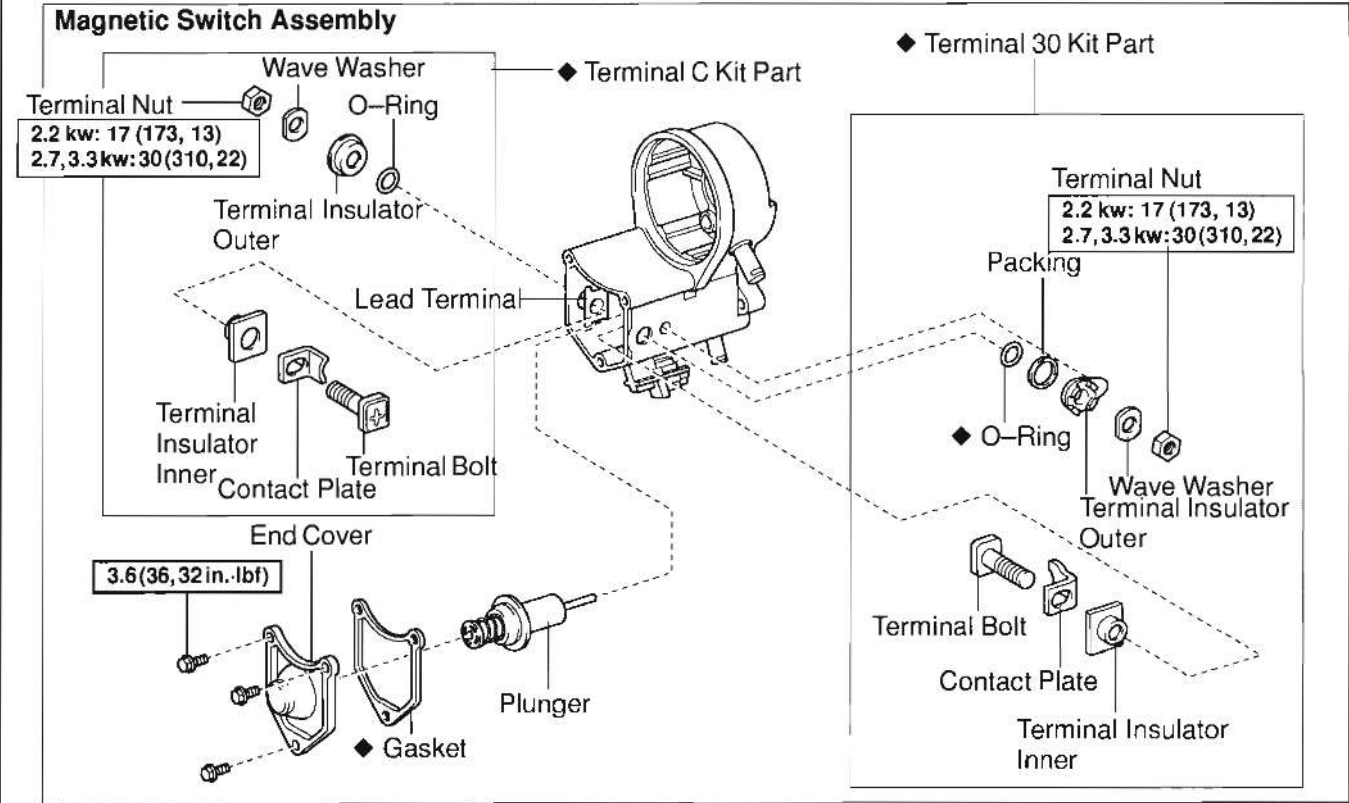

N·m (kgf·cm, ft·lbf) : Specified torque  
 ◆ Non-reusable part

B11524

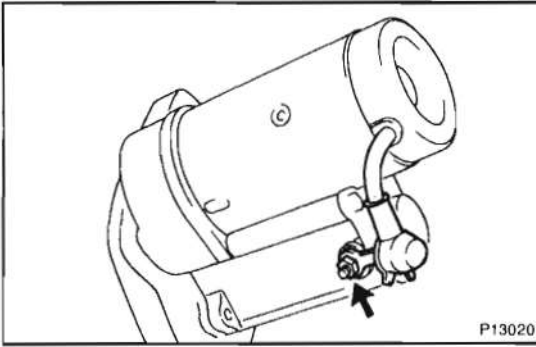

## DISASSEMBLY

### 1. REMOVE FIELD FRAME AND ARMATURE

- (a) Remove the nut, and disconnect the lead wire from the terminal C.

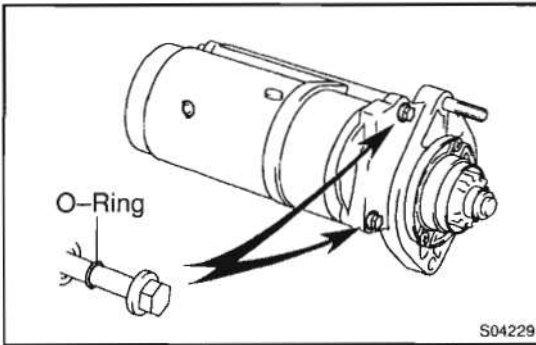

- (b) Remove the 2 through bolts and O-rings.
- (c) Pull out the field frame with the armature from the magnetic switch assembly.
- (d) Remove the O-ring from the field frame.

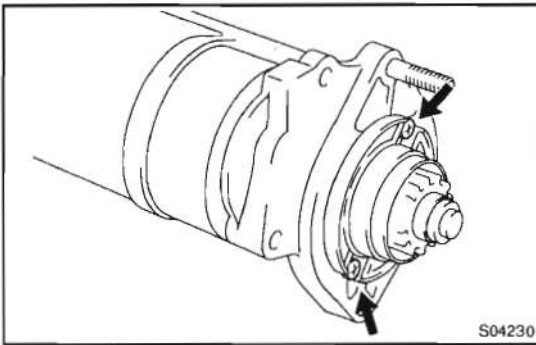

### 2. REMOVE STARTER HOUSING, CLUTCH ASSEMBLY AND GEARS

- (a) Remove the 2 screws.

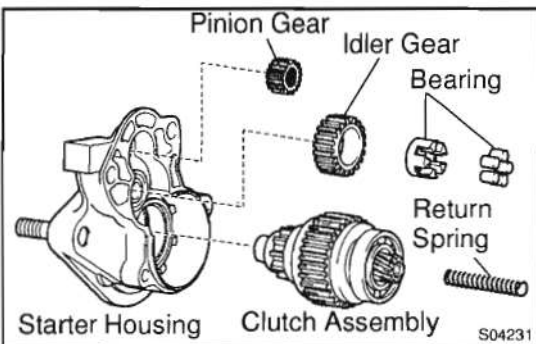

- (b) Remove the starter housing, return spring, pinion gear, bearing, idler gear and clutch assembly from the magnetic switch assembly.

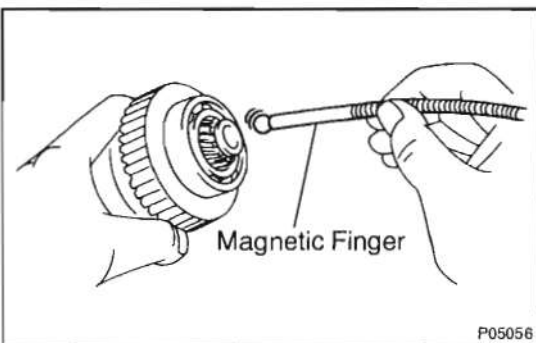

### 3. REMOVE STEEL BALL

- Using a magnetic finger, remove the steel ball from the clutch shaft hole.

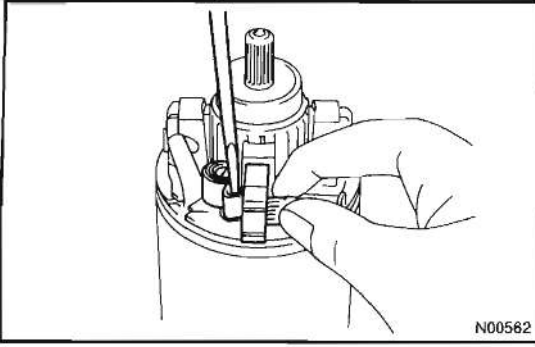
**4. REMOVE BRUSH HOLDER**

Using a screwdriver, hold the spring back and disconnect the brush from the brush holder. Disconnect the 4 brushes and remove the brush holder.

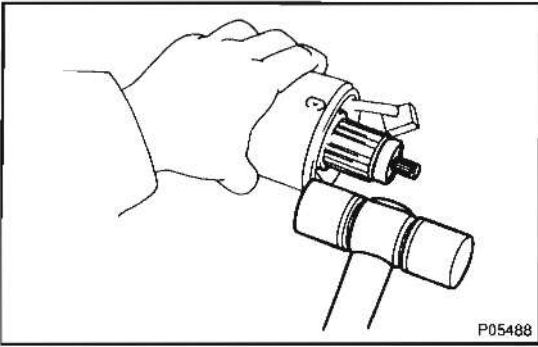
**5. REMOVE ARMATURE FROM FIELD FRAME**

Using a plastic hammer, tap the frame end to remove the armature from the field frame.



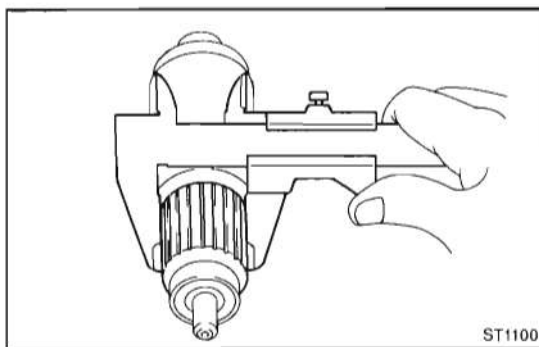
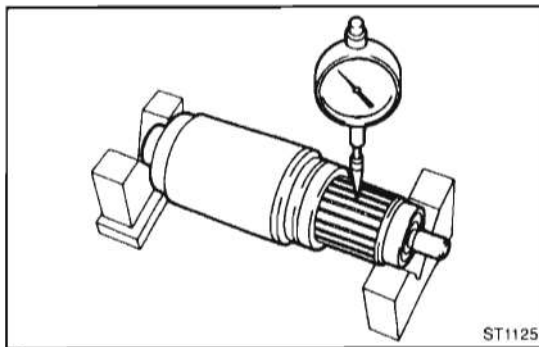
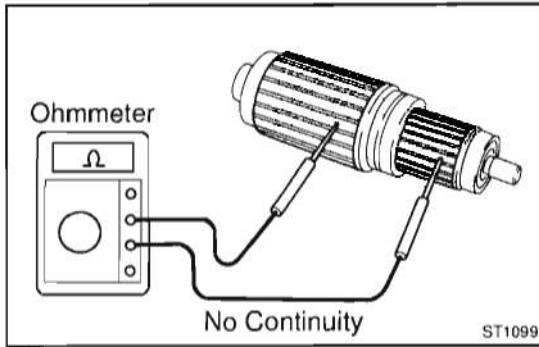
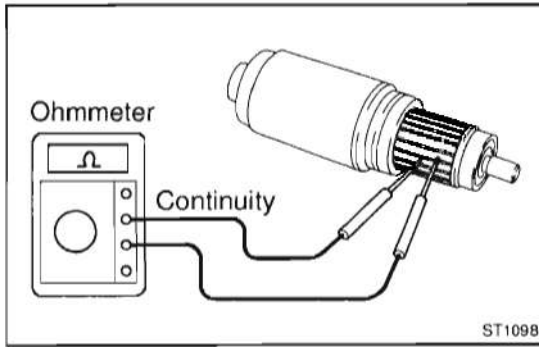

## INSPECTION

### 1. INSPECT ARMATURE COIL

- (a) Check the commutator for open circuit.  
Using an ohmmeter, check that there is continuity between the segments of the commutator.

If there is no continuity between any segment, replace the armature.

- (b) Check the commutator for ground.

Using an ohmmeter, check that there is no continuity between the commutator and armature coil core.

If there is continuity, replace the armature.

### 2. INSPECT COMMUTATOR

- (a) Check the commutator for the dirty and burnt surfaces.  
If the surface is dirty or burnt, correct it with sandpaper (No. 400) or on a lathe.

- (b) Check the commutator circle runout.

(1) Place the commutator on V-blocks.

(2) Using a dial gauge, measure the circle runout.

**Maximum circle runout: 0.05 mm (0.0020 in.)**

If the circle runout is greater than maximum, correct it on a lathe.

- (c) Using vernier calipers, measure the commutator diameter.

**Standard diameter:**

**2.2 kw: 35 mm (1.38 in.)**

**2.7 kw: 36 mm (1.42 in.)**

**3.3 kw: 43 mm (1.69 in.)**

**Minimum diameter:**

**2.2 kw 34 mm (1.34 in.)**

**2.7 kw: 35 mm (1.38 in.)**

**3.3 kw: 42 mm (1.65 in.)**

If the diameter is less than minimum, replace the armature.

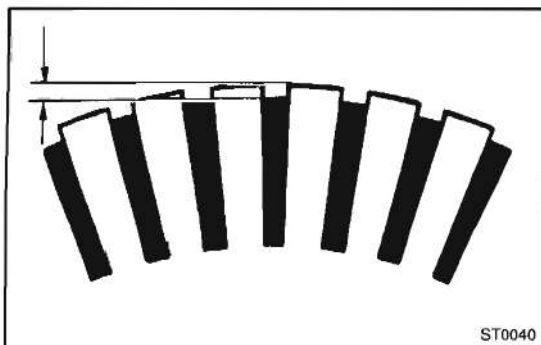

- (d) Check that the undercut depth is clean and free of foreign materials. Smooth out the edge.

**Standard undercut depth: 0.7 mm (0.027 in.)**

**Minimum undercut depth: 0.2 mm (0.008 in.)**

If the undercut depth is less than minimum, correct it with a hacksaw blade.

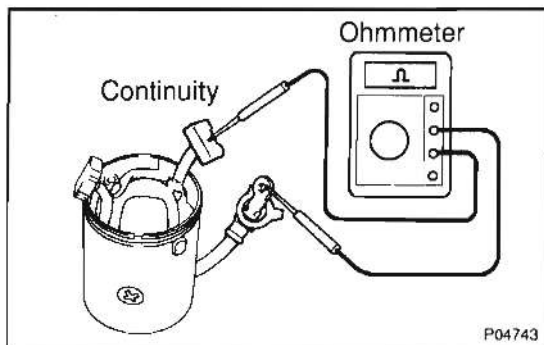

### 3. INSPECT FIELD FRAME

- (a) Check the field coil for open circuit.

Using an ohmmeter, check that there is continuity between the lead wire and field coil brush lead.

If there is no continuity, replace the field frame.

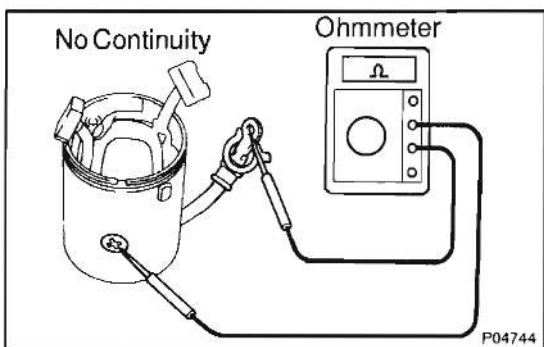

- (b) Check the field coil for ground.

Using an ohmmeter, check that there is no continuity between the field coil end and field frame.

If there is continuity, repair or replace the field frame.

ST

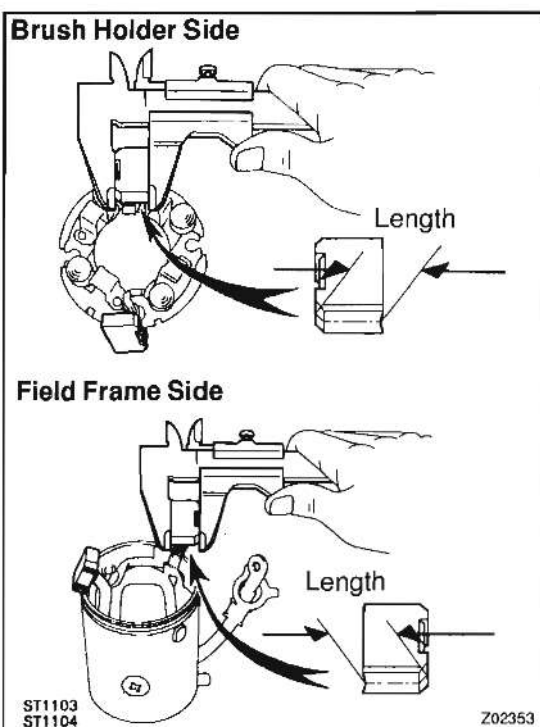

### 4. INSPECT BRUSHES

Check the brushes length.

Using vernier calipers, measure the brush length.

**Standard length:**

**2.2 kw: 16.5 mm (0.650 in.)**

**2.7 kw: 20.5 mm (0.807 in.)**

**3.3 kw: 21.0 mm (0.827 in.)**

**Minimum length:**

**2.2 kw: 9.0 mm (0.354 in.)**

**2.7 kw: 11.0 mm (0.439 in.)**

**2.2 kw: 12.0 mm (0.472 in.)**

If the length is less than minimum, replace the brush holder and field frame.

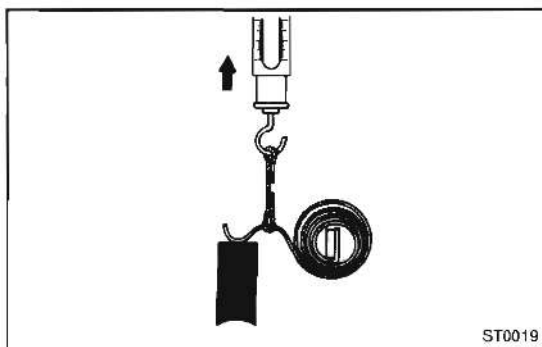

### 5. INSPECT BRUSH SPRINGS

Check the brush spring load.

Take the pull scale reading the instant the brush spring separates from the brush.

**Standard spring installed load:**

**2.2 kw: 26.5 – 32.3 N (2.7 – 3.3 kgf, 5.9 – 7.3 lbf)**

**2.7 kw: 34.3 – 42.1 N (3.5 – 4.3 kgf, 7.7 – 9.5 lbf)**

**3.3 kw: 27.5 – 37.3 N (2.8 – 3.8 kgf, 6.2 – 8.4 lbf)**

**Minimum spring installed load: 17.6 N (1.8 kgf, 4.0 lbf)**

If the installed load is less than minimum, replace the brush springs.

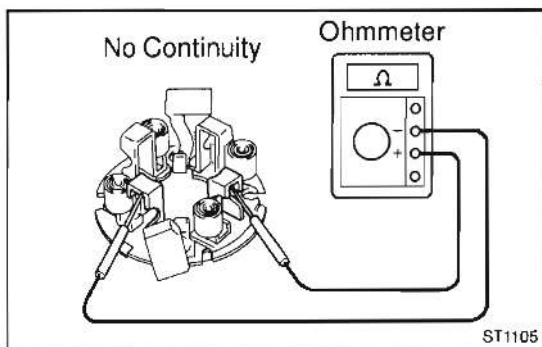

### 6. INSPECT BRUSH HOLDER

Check the brush holder insulation.

Using an ohmmeter, check that there is no continuity between the positive (+) and negative (-) brush holders.

If there is continuity, repair or replace the brush holder.

### 7. INSPECT CLUTCH AND GEARS

(a) Check the gear teeth on the pinion gear, idle gear and clutch assembly for wear or damage.

If damaged, replace the gear or clutch assembly.

If damaged, also check the drive plate ring gear for wear or damage.

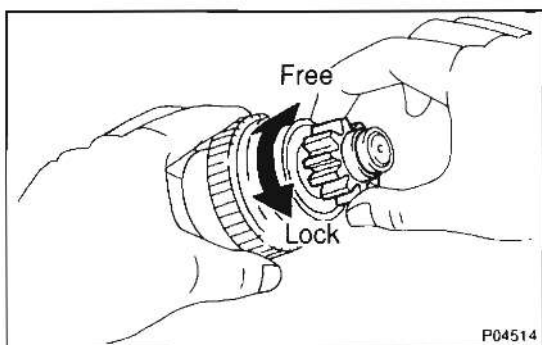

(b) Check the clutch pinion gear.

Hold the starter clutch and rotate the pinion gear clockwise, and check that it turns freely. Try to rotate the pinion gear counterclockwise and check that it locks.

If necessary, replace the clutch assembly.

### 8. INSPECT BEARINGS

Turn the bearing by hand while applying inward force.

If resistance is felt or the bearing sticks, replace the bearing.

(See page ST-12)

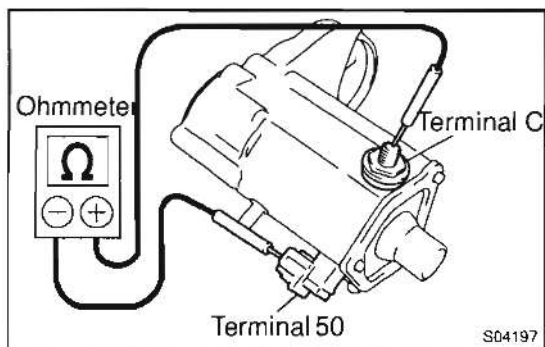

### 9. INSPECT MAGNETIC SWITCH

- (a) Check the pull-in coil for open circuit.  
Using an ohmmeter, check that there is continuity between terminals 50 and C.  
If there is no continuity, replace the magnetic switch.

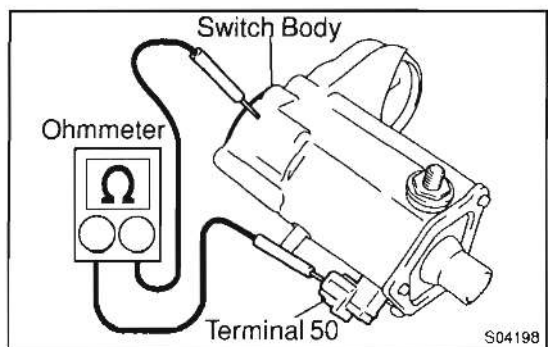

- (b) Check the holding coil for open circuit.  
Using an ohmmeter, check that there is continuity between terminal 50 and the switch body.  
If there is no continuity, replace the magnetic switch.

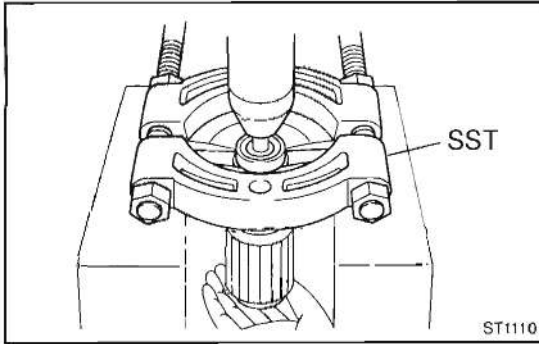

## REPLACEMENT

### 1. REPLACE FRONT BEARING

- (a) Using SST and a press, press out the bearing.  
SST 09950-00020

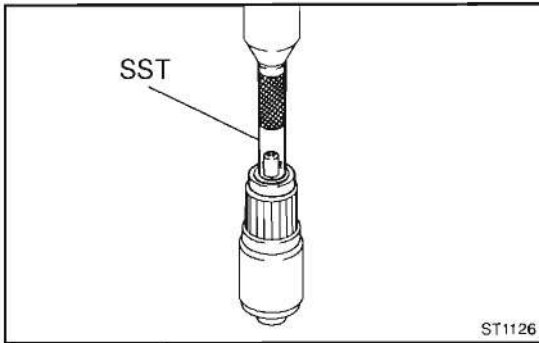

- (b) Using SST and a press, press in a new bearing.  
SST 09201-41020

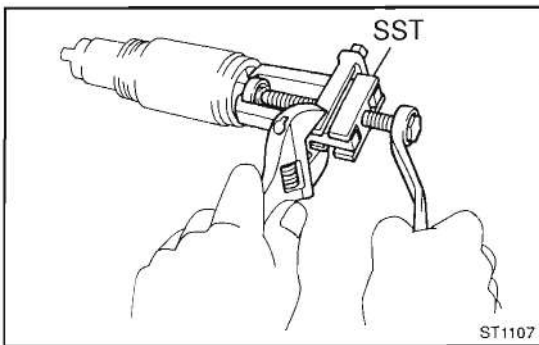

### 2. REPLACE REAR BEARING

- (a) Using SST, remove the bearing.  
SST 09286-46011

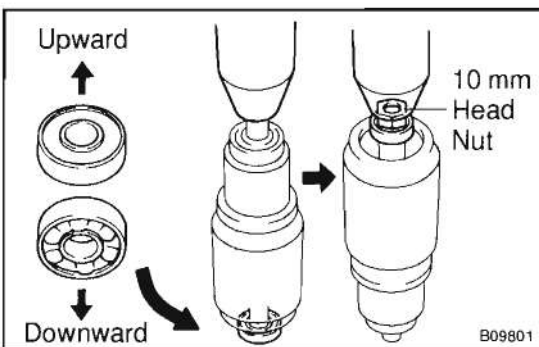

- (b) Using a 10 mm (for thread diameter) nut and press, press in a new bearing.

#### NOTICE:

Be careful of the bearing installation direction.

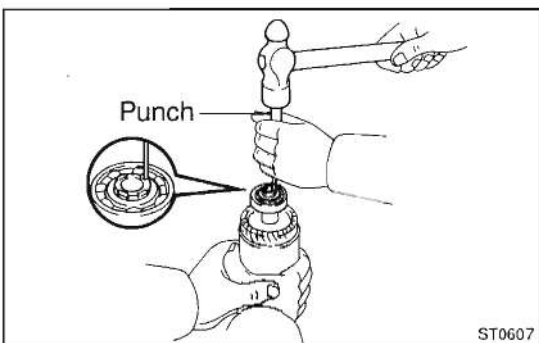

- (c) Using a punch, stake the armature shaft.

### 3. REPLACE MAGNETIC SWITCH TERMINAL KIT PARTS

- (a) Remove the 3 bolts, end cover, gasket and plunger.

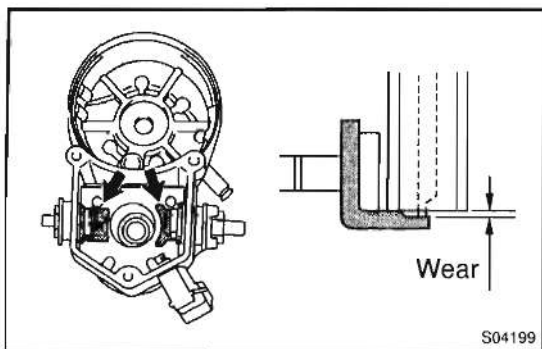

- (b) Inspect the contact plate for wear.  
Using vernier calipers, measure the contact plate for depth of wear.

**Maximum wear:****2.2 kw: 0.9 mm (0.035 in.)****2.7, 3.3 kw: 1.6 mm (0.063 in.)**

If the depth of wear is greater than the maximum, replace the contact plate.

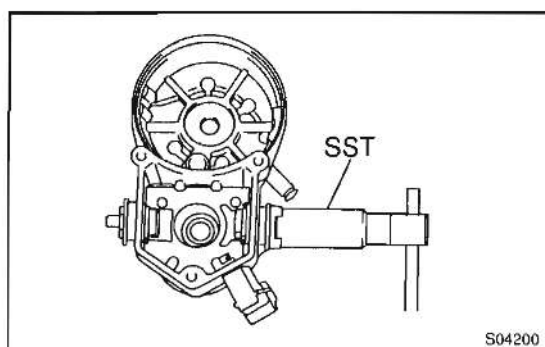

- (c) Remove the terminal kit parts.
- (1) Using SST, loosen the terminal nuts.  
SST 09810-38140
  - (2) Terminal C:  
Remove the terminal nut, wave washer, terminal insulator (outside), O-ring, terminal bolt, contact plate and terminal insulator (inside).
  - (3) Terminal 30:  
Remove the terminal nut, wave washer, terminal insulator (outside), packing, O-ring, terminal bolt, contact plate and terminal insulator (inside).

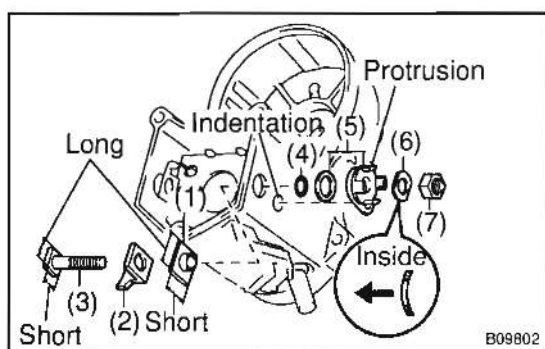

- (d) Install new terminal 30 kit parts.
- (1) Temporarily install a new terminal insulator (inside).
  - (2) Temporarily install a new contact plate.
  - (3) Temporarily install a new terminal bolt.
  - (4) Temporarily install a new O-ring.
  - (5) Temporarily install a new packing and new terminal insulator (outside).

**HINT:**

Match the protrusion of the insulator with the indentation of the housing.

- (6) Temporarily install a new wave washer.
- (7) Temporarily install a new terminal nut.

**NOTICE:**

**Be careful to install the terminal insulators (inside) and wave washer and terminal bolt in the correct direction.**

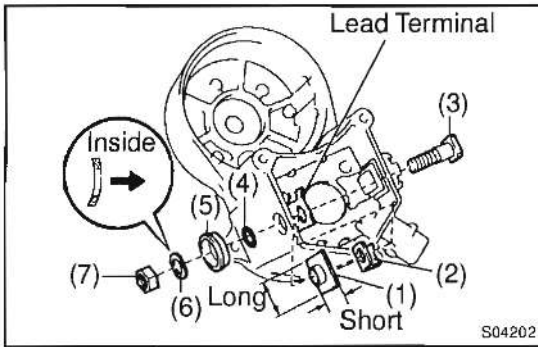

- (e) Install new terminal C kit parts.
- (1) Temporarily install a new terminal insulator (inside).
  - (2) Temporarily install a new contact plate.
  - (3) Temporarily install a new terminal bolt.
  - (4) Temporarily install a new O-ring.
  - (5) Temporarily install a new terminal insulator (outside).
  - (6) Temporarily install a new wave washer.
  - (7) Temporarily install a new terminal nut.

**NOTICE:**

**Be careful to install the terminal insulators (inside) and wave washer in the correct direction.**

- (f) Temporarily tighten the terminal nuts.

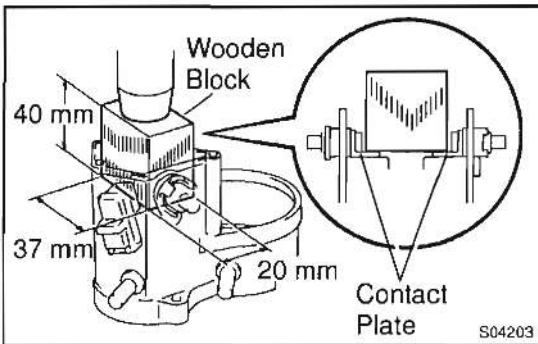

- (g) Tighten the terminal nuts.
- (1) Put a wood block on the contact plate and press it down with a hand press.

**Dimensions of wood block:**

**20 x 37 x 40 mm (0.97 x 1.46 x 1.57 in.)**

**Press force: 981 N (100 kgf, 221 lbf)**

**NOTICE:**

- **Check the diameter of the hand press ram. Then calculate the gauge pressure of the press when 981 N (100 kgf, 221 lbf) of force is applied.**

**Gauge pressure**

$$(\text{kgf/cm}^2) = \frac{100 \text{ kgf}}{\left(\frac{\text{Ram diameter (cm)}}{2}\right)^2 \times 3.14 (\pi)}$$

$$(\text{psi}) = \frac{221 \text{ lbf}}{\left(\frac{\text{Ram diameter (in.)}}{2}\right)^2 \times 3.14 (\pi)}$$

$$(\text{kPa}) = (\text{kgf/cm}^2) \times 98.1$$

$$(\text{kPa}) = (\text{psi}) \times 6.9$$

- **If the contact plate is not pressed down with the specified pressure, the contact plate may tilt due to coil deformation or the tightening of the nut.**

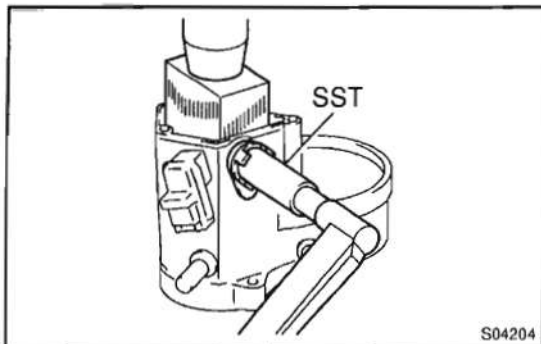

(2) Using SST, tighten the nuts to the specified torque.

SST 09810-38140

**Torque:**

2.2 kw: 17 N·m (173 kgf·cm, 13 ft·lbf)

2.7, 3.3 kw: 30 N·m (310 kgf·cm, 22 ft·lbf)

**NOTICE:**

If the nut is over tightened, it may cause cracks on the inside of the insulator.

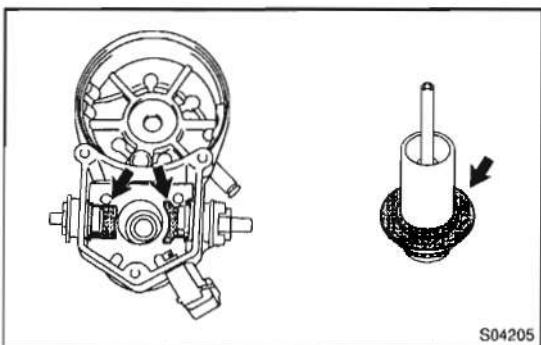

(h) Clean the contact surfaces of the remaining contact plate and plunger with a dry shop rag.

(i) Reinstall the plunger, a new gasket and end cover with the 3 bolts.

**Torque: 3.6 N·m (36 kgf·cm, 32 in.-lbf)**



## REASSEMBLY

### HINT:

Use high-temperature grease to lubricate the bearings and gears when assembling the starter.

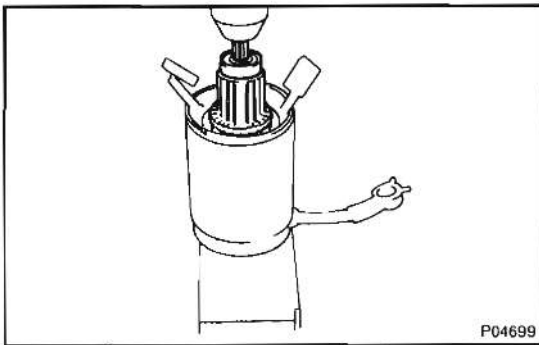

### 1. PLACE ARMATURE INTO FIELD FRAME

- (a) Apply a grease to the armature bearings.
- (b) Using a press, press the armature into the field frame.

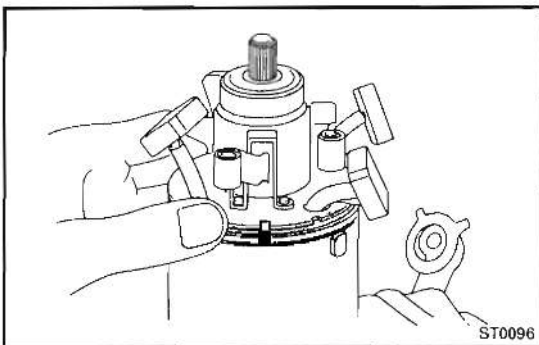

### 2. INSTALL BRUSH HOLDER

- (a) Align the claw of the brush holder with the claw groove of the field frame.
- (b) Place the brush holder on the field frame.

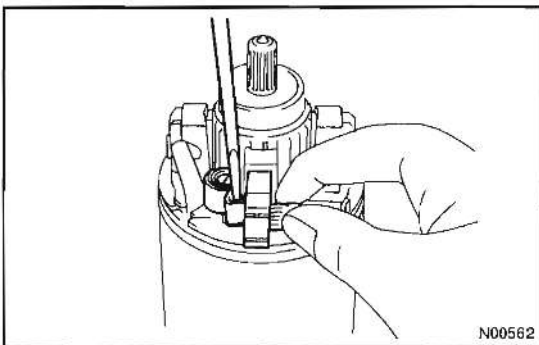

- (c) Using a screwdriver, hold the brush spring back, and connect the brush into the brush holder. Contact the 4 brushes.

### NOTICE:

Check that the positive (+) lead wires are not grounded.

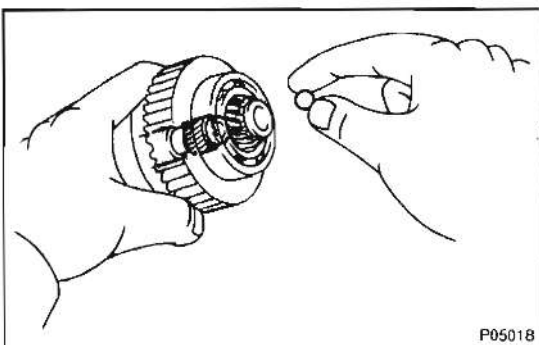

### 3. INSERT STEEL BALL INTO CLUTCH SHAFT HOLE

- (a) Apply grease to the steel ball.
- (b) Insert the steel ball into the clutch shaft hole.

### 4. INSTALL STARTER HOUSING, CLUTCH ASSEMBLY AND GEARS

- (a) Apply grease to the return spring.
- (b) Insert the return spring into the magnetic switch hole.

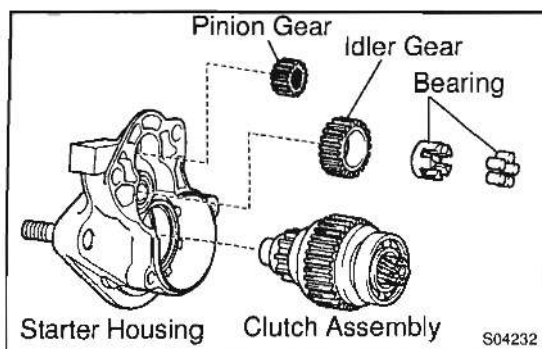

- (c) Place the starter housing, pinion gear, bearing, idler gear and clutch assembly on the starter housing.

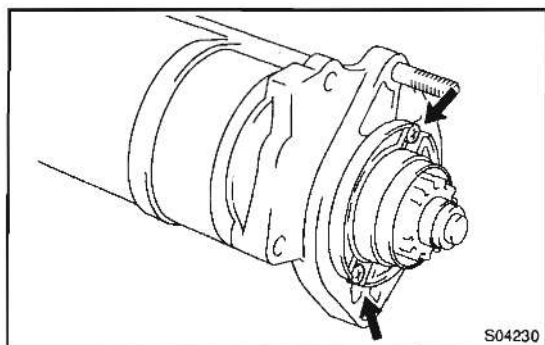

- (d) Assemble the starter housing and magnetic switch assembly and install the 2 screws.

**Torque:**

**2.2, 2.7 kw: 9.3 N·m (95 kgf·cm, 82 in.-lbf)**

**3.3 kw: 11 N·m (115 kgf·cm, 8 ft.-lbf)**

**5. INSTALL FIELD FRAME AND ARMATURE ASSEMBLY**

- (a) Place a new O-ring in position on the field frame.

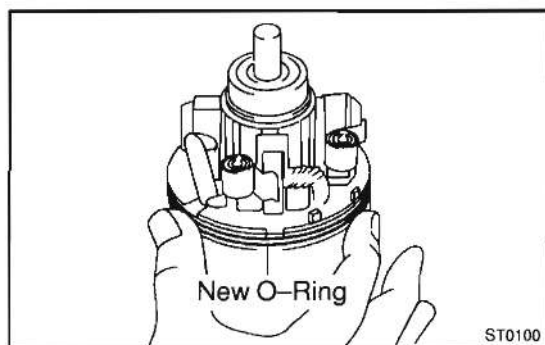

- (b) Align the claws of the brush holder with the grooves of the magnetic switch, and install the field frame and armature shaft assembly.

- (c) Align the punch mark of the field frame with the line of the magnet switch.

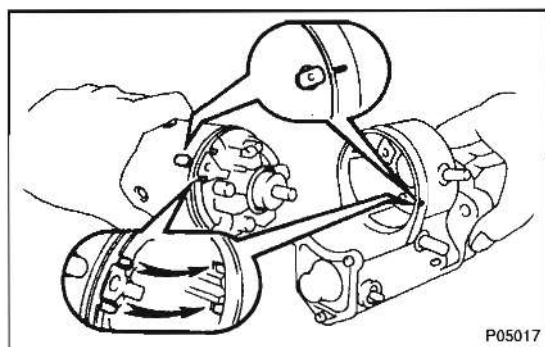

- (d) Install a new O-rings to the through bolts.

- (e) Install the field frame and armature assembly with the 2 through bolts.

**Torque:**

**2.2 kw: 13 N·m (130 kgf·cm, 9 ft.-lbf)**

**2.7 kw: 14 N·m (145 kgf·cm, 10 ft.-lbf)**

**3.3 kw: 9.3 N·m (95 kgf·cm, 82 in.-lbf)**

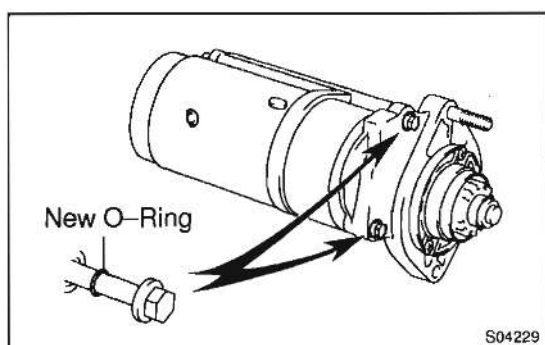

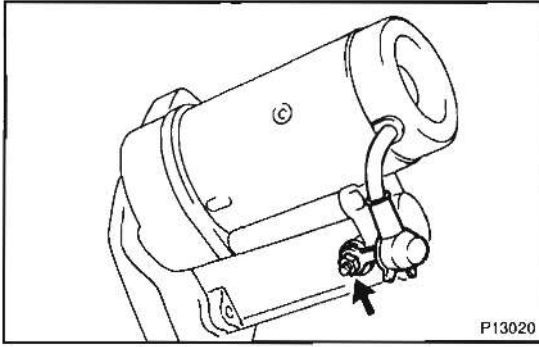

- (f) Connect the lead wire to terminal C, and install the nut.

**Torque:**

**2.2 kw: 5.9 N·m (60 kgf·cm, 52 in·lbf)**

**2.7, 3.3 kw: 24 N·m (240 kgf·cm, 17 ft·lbf)**

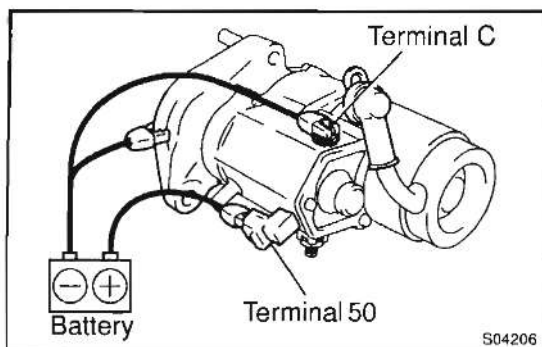

## TEST

### NOTICE:

These tests must be performed within 3 to 5 seconds to avoid burning out the coil.

#### 1. PERFORM PULL-IN TEST

- (a) Disconnect the field coil lead wire from terminal C.
- (b) Connect the battery to the magnetic switch as shown. Check that the clutch pinion gear moves outward.

If the clutch pinion gear does not move, replace the magnetic switch assembly.

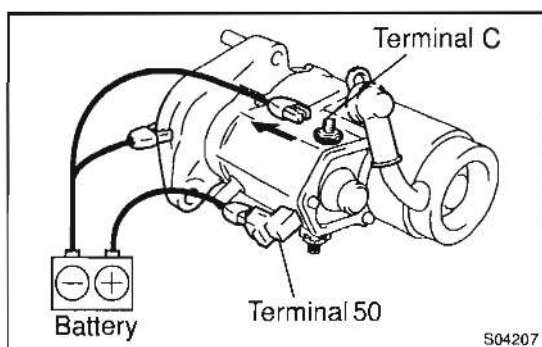

#### 2. PERFORM HOLDING TEST

With battery connected as above with the clutch pinion gear out, disconnect the negative (-) lead from terminal C. Check that the pinion gear remains out.

If the clutch pinion gear returns inward, replace the magnetic switch assembly.

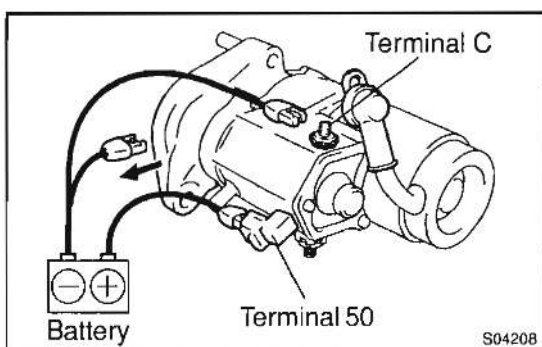

#### 3. INSPECT CLUTCH PINION GEAR RETURN

Disconnect the negative (-) lead from the switch body. Check that the clutch pinion gear returns inward.

If the clutch pinion gear does not return, replace the magnetic switch assembly.

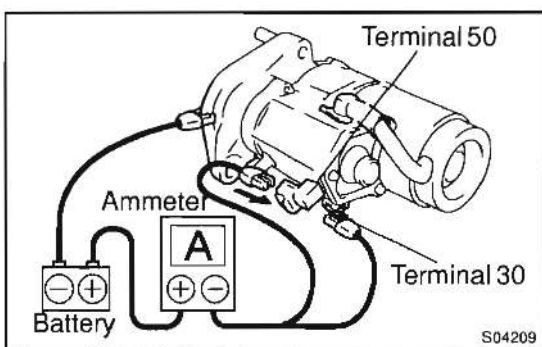

#### 4. PERFORM NO-LOAD PERFORMANCE TEST

- (a) Connect the battery and ammeter to the starter as shown.
- (b) Check that the starter rotates smoothly and steadily with the pinion gear moving out. Check that the ammeter shows the specified current.

##### Specified current:

2.2 kw: 120 A or less at 11.5V

2.7 kw: 180 A or less at 11.0V

2.2 kw: 220 A or less at 11.0V

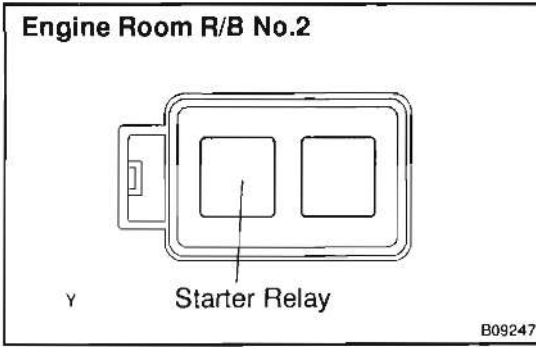

## STARTER RELAY INSPECTION

### 1. REMOVE STARTER RELAY

Remove the starter relay. (Marking: ST RLY)

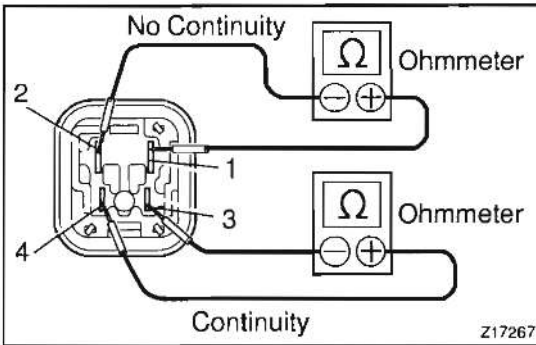

### 2. INSPECT STARTER RELAY

(a) Inspect the relay continuity.

- (1) Using an ohmmeter, check that there is continuity between terminals 3 and 4.

If there is no continuity, replace the relay.

- (2) Check that there is no continuity between terminal 1 and 2.

If there is continuity, replace the relay.

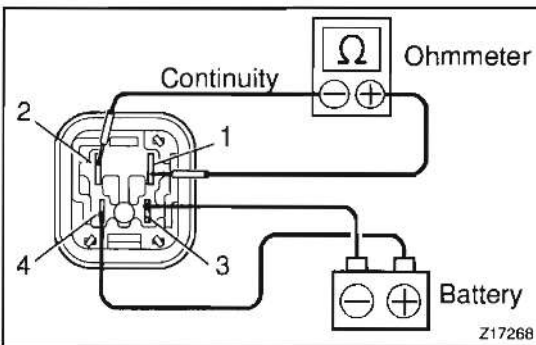

(b) Inspect the relay operation.

- (1) Apply battery voltage across terminals 3 and 4.

- (2) Using an ohmmeter, check that there is continuity between terminals 1 and 2.

If there is no continuity, replace the relay.

### 3. REINSTALL STARTER RELAY

