

EG1-308

5S-FE ENGINE - FAIL-SAFE CHART

FAIL-SAFE CHART

If any of the following codes is recorded, the ECM enters fail-safe mode.

DTC No.	Fail-Safe Operation	Fail-Safe Deactivation Conditions
14	Fuel cut	1 IGF detected in consecutive 2 (4*) ignitions.
16	Torque control prohibited.	Returned to normal condition.
22	THW is fixed at 80°C (176°F).	Returned to normal condition.
24	THA is fixed at 20°C (68°F).	Returned to normal condition.
31	<ul style="list-style-type: none"> • Ignition timing fixed at 51° BTDC. • Injection time fixed <ul style="list-style-type: none"> Starting 12.1 m sec. IDL ON 3.3 m sec. IDL OFF 6.1 m sec. • Intake manifold vacuum is fixed at 46.7 kPa. (350 mmHg, 13.8 inHg) 	Returned to normal condition.
41	VTA1 is fixed at 0°.	The following must each be repeated at least 2 time consecutively. <ul style="list-style-type: none"> • $0.1\text{ V} \leq \text{VTA} \leq 0.95\text{ V}$ • IDL : ON
52	Max. timing retardation.	IG switch OFF.

*: Only for California specification vehicles.

Back-Up Function

If there is trouble with the program in the ECM and the ignition signals (IGT) are not output from microcomputer the ECM controls fuel injection and ignition timing at predetermined levels as a back-up function to make it possible to continue to operate the vehicle.

Furthermore, the injection duration is calculated from the starting signal (STA) and the throttle position signal (IDL). Also, the ignition timing is fixed at the initial ignition timing, 51° BTDC, without relation to the engine speed.

HINT: If the engine is controlled by the back-up function, the malfunction indicator lamp lights up to warn the driver of the malfunction but the diagnostic trouble code is not output.

CHECK FOR MOMENTARY INTERRUPTION

As described in the preceding paragraph, abnormality detection ability in the test mode is increased compared to that in the normal mode, so that when momentary interruptions or momentary shorts occur in the ECM signal circuits (G, NE, THW, THA, PIM, VTA) shown in the table below, the appropriate diagnostic trouble code is output.

Accordingly, when the diagnostic trouble codes shown in the table below (13, 22, 24, 31, 41) are output during the diagnostic trouble code check, and inspection of the appropriate circuits reveals no abnormality, perform the check for momentary interruption as described below.

By performing the check for momentary interruption, the place where momentary interruptions or momentary shorts are occurring due to poor contacts can be isolated.

DTC	Circuit
13	G, NE signal circuit (No.2)
22	Engine coolant temp. sensor circuit
24	Intake air temp. sensor circuit
31	Manifold absolute pressure sensor circuit
41	Throttle position sensor circuit

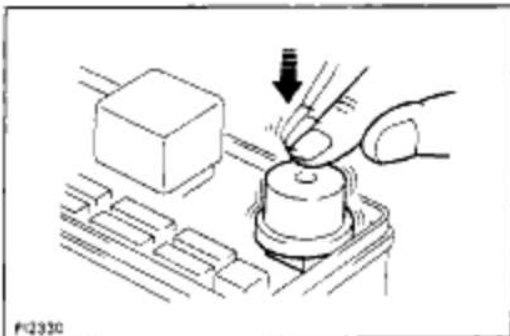
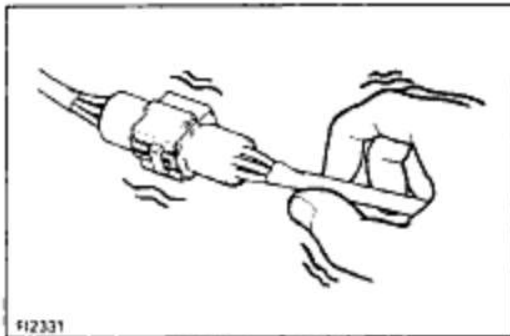

CLEAR DIAGNOSTIC TROUBLE CODES

See page [EG1-299](#).

SET TEST MODE

1. With the ignition switch off, using SST, connect the terminals TE2 and E1 of the data link connector 1 and 2. SST 09843-18020
2. Start the engine and check to see the malfunction indicator lamp to go off.

PERFORM A SIMULATION TEST

Using the symptom simulation (See page IN-24), apply vibration to and pull lightly on the wire harness, connector or terminals in the circuit indicated by the malfunction code.

In this test, if the malfunction indicator lamp light up, it indicates that the place where the wire harness, connector or terminals being pulled or vibrated has faulty contact. Check that point for loose connections, dirt on the terminals, poor fit or other problems and repair as necessary.

HINT: After cancelling out the diagnostic trouble code in memory and set the test mode, if the malfunction indicator lamp does not go off after the engine is started, check thoroughly for faulty contact, etc., then try the check again. If the malfunction indicator lamp still does not go off, check and replace ECM.

EG1-310

5S-FE ENGINE - BASIC INSPECTION

BASIC INSPECTION

When the normal code is displayed in the diagnostic trouble code check, troubleshooting should be performed in the order for all possible circuits to be considered as the causes of the problems. In many cases, by carrying out the basic engine check shown in the following flow chart, the location causing the problem can be found quickly and efficiently. Therefore, use of this check is essential in engine troubleshooting.

Is battery positive voltage 11 V or more when engine is stopped?

YES

NO

Charge or replace battery.

Is engine cranked ?

YES

NO

Proceed to matrix chart of problem symptoms on page [EG1-327](#).

Does engine start

YES

NO

Go to step 

Check air filter.

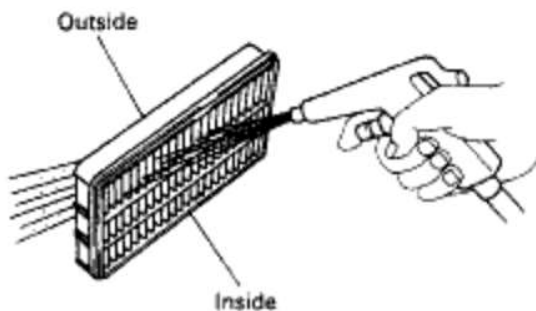

- P** Remove air filter.
- C** Visually check that the air filter is not excessively damaged or oily.
- Info** If necessary, clean the air filter with compressed air. First blow from inside thoroughly, then blow off outside of the air filter.

OK

NG

Repair or replace.

Go to step 

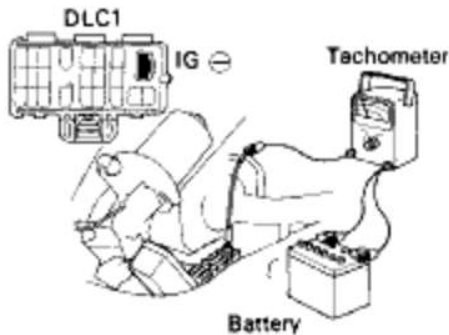
5**Check idle speed.**

P00491

- P** (1) Shift transmission into "N" position or neutral.
 (2) Warm up engine at normal operating temperature.
 (3) Switched off all accessories.
 (4) Switched off air conditioning.
 (5) Connect tachometer test probe to terminal IG (-) of data link connector 1, and set the tachometer to the 4-cylinder range.

C Check idle speed.

OK Idle speed: 700 ~ 800 rpm

- Caution**
- **NEVER** allow tachometer test probe to touch ground as it could result in damage to igniter and/or ignition coil.
 - As some tachometers are not compatible with this ignition system, we recommended that you confirm compatibility of your unit before use.

OK**NG**

Proceed to matrix chart of problem symptoms on page [EG1-327](#).

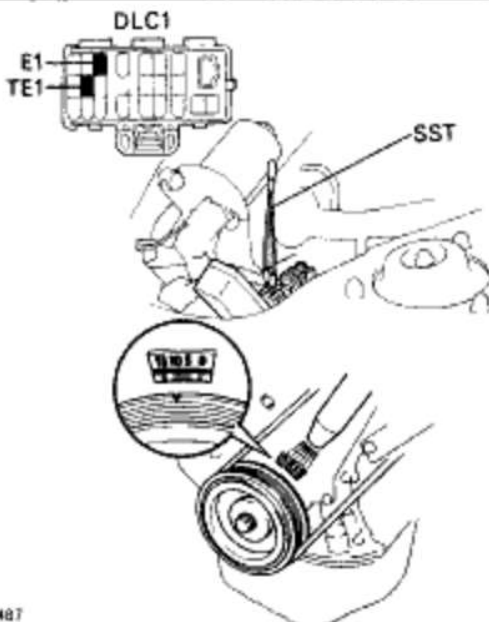
6**Check ignition timing.**P00487
P02210

- P** (1) Shift transmission into "N" position or neutral.
 (2) Warm up engine at normal operating temperature.
 (3) Keep the engine speed at idle.
 (4) Using SST, connect terminals TE1 and E1 of data link connector 1.
 SST 09843-18020
 (5) Using a timing light, connect the tester to No. 1 high-tension cord.

C Check ignition timing.

OK Ignition timing: 10° BTDC at idle

OK**NG**

Proceed to page [IG-19](#), 38* and continue to troubleshoot.

*Except California specification vehicles.

Proceed to matrix chart of problem symptoms on page [EG1-327](#).

EG1-312

5S-FE ENGINE - BASIC INSPECTION

Check fuel pressure.

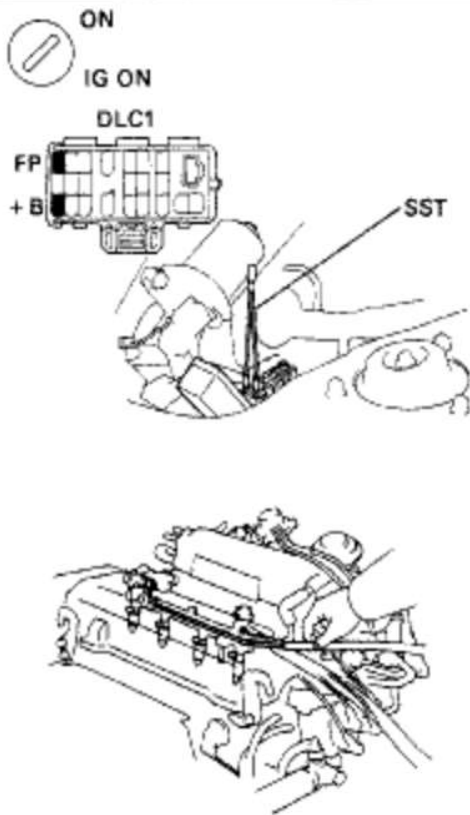

8E8653
P20486
P91500

- P** (1) Be sure that fuel is enough in tank.
 (2) Turn ignition switch on.
 (3) Using SST, connect terminals FP and + B of data link connector 1.

SST 09843-18020

- C** Check for fuel pressure in the return hose when it is pinched off.

Hint At this time, you will hear fuel return noise.

Caution
 Never make a mistake with the terminal connection position as this will cause a malfunction.

OK

NG

Proceed to page [EG1-178](#) and continue to troubleshoot.

Check for spark.

- C** Disconnect the high-tension cord from the distributor and, hold the end about 12.5 mm (1/2") from the ground, see if spark occurs while the engine is being cranked.

Hint To prevent excessive fuel injected from the injectors during this test, don't crank the engine for more than 1-2 seconds at a time.

OK

NG

Proceed to page [IG-6, 26*](#) and continue to troubleshoot.

* : Except California specification vehicles.

Proceed to matrix chart of problem symptoms on page [EG1-327](#).