

Last Modified: 9-29-2009	5.6 A	From: 200501
Model Year: 2006	Model: Hiace	Doc ID: RM00000128D000X
Title: 5L-E ENGINE MECHANICAL: CYLINDER HEAD: INSTALLATION (2006-2010 Hiace)		

INSTALLATION

1. INSPECT CYLINDER HEAD SET BOLT

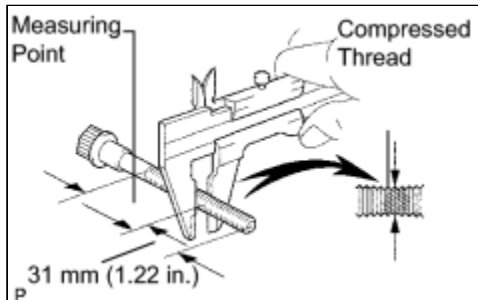

- (a) Using vernier calipers, measure the minimum outer diameter of the compressed thread at the measuring point.

Standard outer diameter:

11.80 to 12.00 mm (0.4646 to 0.4724 in.)

Minimum outer diameter:

11.60 mm (0.4567 in.)

If the outer diameter is less than the minimum, replace the bolt.

2. INSTALL CYLINDER HEAD GASKET

- (a) Check piston protrusion for each cylinder.

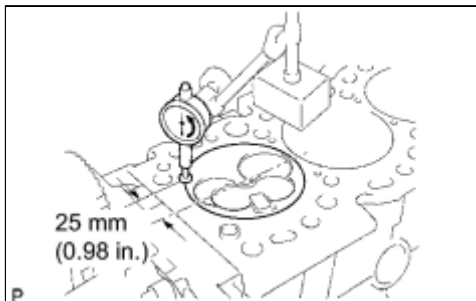

- (1) Clean the cylinder block with solvent.
- (2) Set the piston of the cylinder to be measured to slightly before TDC.
- (3) Place a dial indicator on the cylinder block, and set the measuring tip as shown in the illustration.
- (4) Set the dial indicator at 0 mm (0 in.).

HINT:

- Use a dial indicator measuring tip as shown in the illustration.
- Make sure that the measuring tip is square to the cylinder block gasket surface and piston head when taking the measurements.

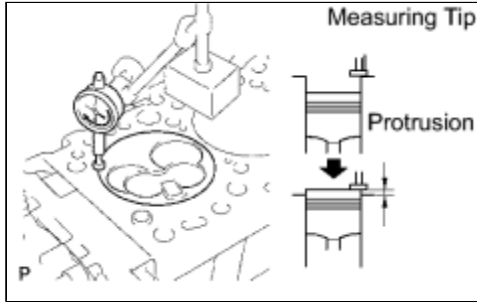

- (5) Find where the piston head protrudes most by slowly turning the crankshaft clockwise and counterclockwise.

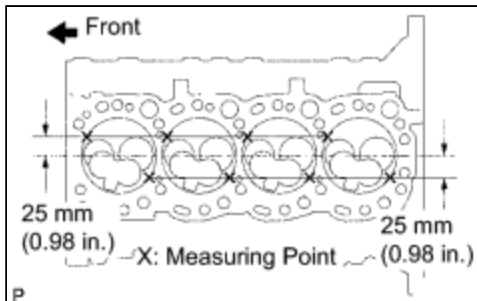

- (6) Measure the protrusion of each cylinder at 2 places as shown in the illustration, making a total of 8 measurements.

- (7) For the piston protrusion value of each cylinder, use the average of the 2 measurements of each cylinder.

Protrusion:

0.68 to 0.97 mm (0.00268 to 0.0382 in.)

HINT:

If the protrusion is not as specified, remove the piston and connecting rod assembly and reinstall it.

- (b) Select a new cylinder head gasket.

HINT:

There are 3 sizes of new cylinder head gaskets, marked "B", "D" or "F" accordingly.

New installed cylinder head gasket thickness:

Mark B	1.40 to 1.50 mm (0.0551 to 0.0591 in.)
Mark D	1.50 to 1.60 mm (0.0591 to 0.0630 in.)
Mark F	1.60 to 1.70 mm (0.0630 to 0.0669 in.)

- (1) Select the largest piston protrusion value from the

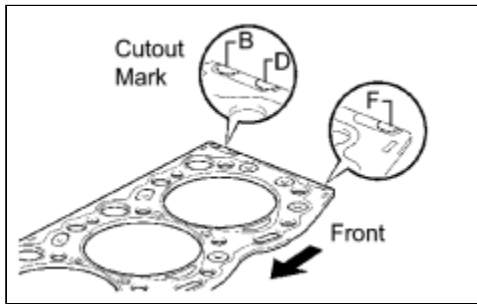

measurements made, then select a new appropriate gasket according to the table below.

PISTON PROTRUSION MM (IN.)	GASKET SIZE
0.68 to 0.77 (0.0268 to 0.0303)	Use B
0.78 to 0.87 (0.0307 to 0.0343)	Use D
0.88 to 0.97 (0.0346 to 0.0382)	Use F

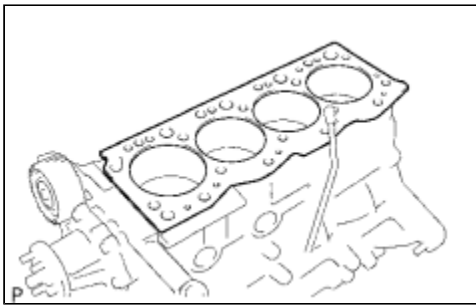

(c) Place a new cylinder head gasket in position on the cylinder block.

NOTICE:

Be careful of the installation direction.

3. INSTALL CYLINDER HEAD SUB-ASSEMBLY

HINT:

Set the No.1 cylinder to 90° BTDC/compression to avoid interference with the piston top and valve head.

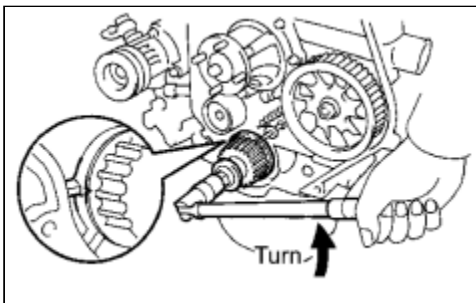

(a) Using the crankshaft pulley bolt, turn the crankshaft 90° counterclockwise, and align the timing mark of the crankshaft timing pulley with the protrusion of the timing belt case.

(b) Place the cylinder head in position on the cylinder head gasket.

(c) Install cylinder head bolts.

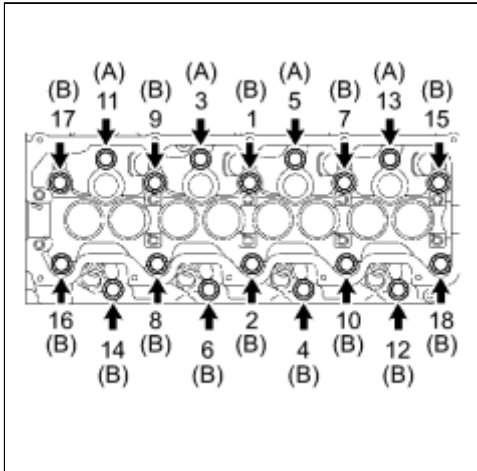

HINT:

- The cylinder head bolts are tightened in 3 progressive steps (steps (2), (4) and (5))
- If any bolt is broken or deformed, replace it.

- (1) Apply a light coat of engine oil to the threads and under the heads of the cylinder head bolts.
- (2) Install and uniformly tighten the 18 cylinder head bolts, in several steps, in the sequence shown.

Torque: 78 N·m (800 kgf·cm, 58ft·lbf)

HINT:

Each bolt length is indicated below.

Bolt length:

107 mm (4.21 in.) for A

127 mm (5.00 in.) for B

If any one of the cylinder head bolts does not meet the torque specification, replace the cylinder head bolt.

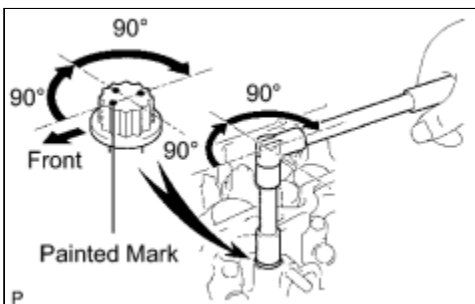

- (3) Mark the front of the cylinder head bolt with paint.

- (4) Retighten the cylinder head bolts 90° in the numerical order shown.
- (5) Retighten the cylinder head bolts by an additional 90°.
- (6) Check that the painted mark is now facing rearward.

4. INSTALL CYLINDER HEAD COVER SUB-ASSEMBLY[INFO](#)**5. INSTALL GLOW PLUG NO.1 CONNECTOR**[INFO](#)**6. INSTALL INJECTION PIPE SET**[INFO](#)**7. INSTALL EXHAUST PIPE SUB-ASSEMBLY FROM NO.1 (for Long Wheelbase)**[INFO](#)**8. INSTALL EXHAUST PIPE SUB-ASSEMBLY FROM NO.1**[INFO](#)**9. INSTALL EXHAUST PIPE SUB-ASSEMBLY FRONT NO.2 (for Long Wheelbase)**[INFO](#)**10. INSTALL EXHAUST PIPE SUB-ASSEMBLY FRONT NO.2 (for Super Long Wheelbase)**[INFO](#)**11. INSTALL EXHAUST MANIFOLD HEAT INSULATOR NO.1**[INFO](#)**12. INSTALL VENTURI ASSEMBLY**[INFO](#)**13. INSTALL INTAKE AIR CONNECTOR SUB-ASSEMBLY**[INFO](#)**14. CONNECT AIR CLEANER HOSE NO.2**[INFO](#)**15. INSTALL TIMING BELT**[INFO](#)**16. CONNECT CABLE TO NEGATIVE BATTERY TERMINAL****17. BLEED AIR FROM FUEL SYSTEM**[INFO](#)**18. ADD ENGINE COOLANT**[INFO](#)**19. CHECK FOR ENGINE COOLANT LEAKS**[INFO](#)**20. CHECK FOR FUEL LEAKS**[INFO](#)**21. CHECK FOR EXHAUST GAS LEAKS****22. CHECK IDLE SPEED**[INFO](#)

23. INSPECT MAXIMUM ENGINE SPEED



24. PERFORM INITIALIZATION

