

OIL AND FILTER INSPECTION

LU08N-04

1. CHECK ENGINE OIL QUALITY

Check the oil for deterioration, entry of water, discoloring or thinning.

If the quality is visibly poor, replace the oil.

Oil grade:

API grade SL Energy-Conserving or ILSAC multi-grade engine oil.

2. CHECK ENGINE OIL LEVEL

The oil level should be between the "L" and "F" marks on the dipstick.

If low, check for leakage and add oil up to the "F" mark.

NOTICE:

- ★ Do not fill with engine oil above the "F" mark.

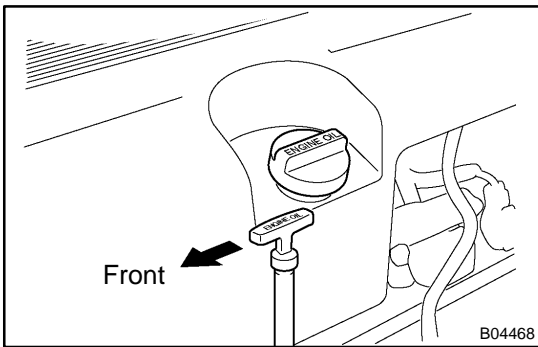

- ★ Install the oil dipstick facing the direction shown in the illustration.

3. REMOVE ENGINE UNDER COVER NO.1

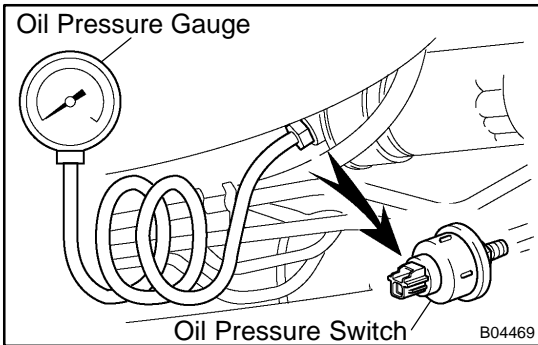

4. REMOVE OIL PRESSURE SWITCH

5. INSTALL OIL PRESSURE GAUGE

6. WARM UP ENGINE

Allow the engine to warm up to normal operating temperature.

7. CHECK OIL PRESSURE

Oil pressure:

At idle: 29 kPa (0.3 kgf/cm², 4.2 psi) or more

At 3,000 rpm:

294 - 588 kPa (3.0 - 6.0 kgf/cm², 43 - 85 psi)

8. REMOVE OIL PRESSURE GAUGE

9. REINSTALL OIL PRESSURE SWITCH

- (a) Apply adhesive to 2 or 3 threads of the oil pressure switch.

Adhesive:

Part No. 08833-00080, THREE BOND 1344, LOCTITE 242 or equivalent

- (b) Reinstall the oil pressure switch.

10. START ENGINE, AND CHECK FOR ENGINE OIL LEAKS

11. REINSTALL ENGINE UNDER COVER NO.1

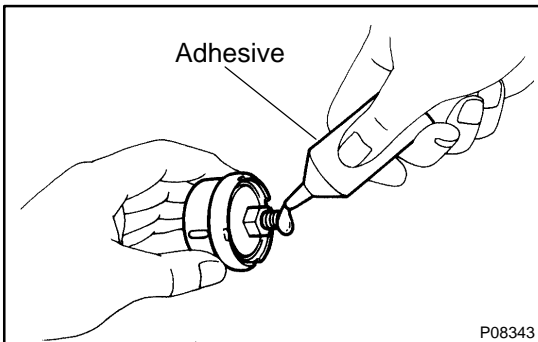

REPLACEMENT

CAUTION:

- ★ Prolonged and repeated contact with mineral oil will result in the removal of natural fats from the skin, leading to dryness, irritation and dermatitis. In addition, used engine oil contains potentially harmful contaminants which may cause skin cancer.
- ★ Care should be taken, therefore, when changing engine oil to minimize the frequency and length of time your skin is exposed to used engine oil. Protective clothing and gloves that cannot be penetrated by oil should be worn. The skin should be thoroughly washed with soap and water, or use water-less hand cleaner, to remove any used engine oil. Do not use gasoline, thinners, or solvents.
- ★ In order to preserve the environment, used oil and used oil filters must be disposed of only at designated disposal sites.

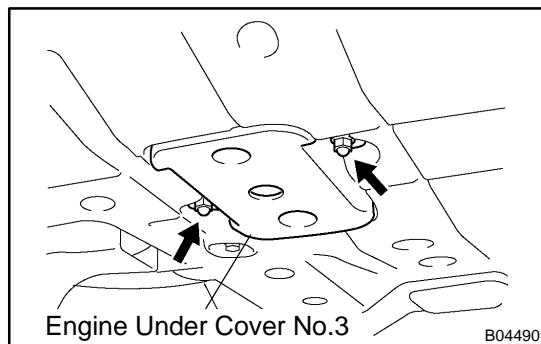

1. DRAIN ENGINE OIL

- (a) Remove the 2 nuts and engine under cover No.3.

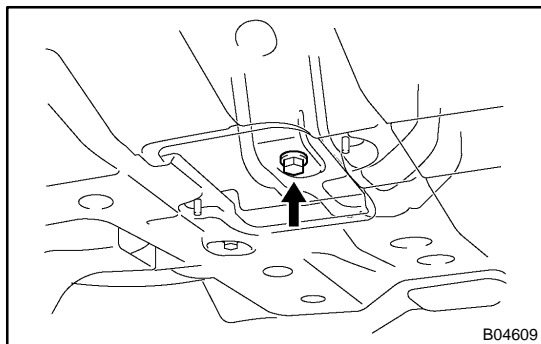

- (b) Remove the oil filler cap.
 (c) Remove the oil drain plug, and drain the oil into a container.

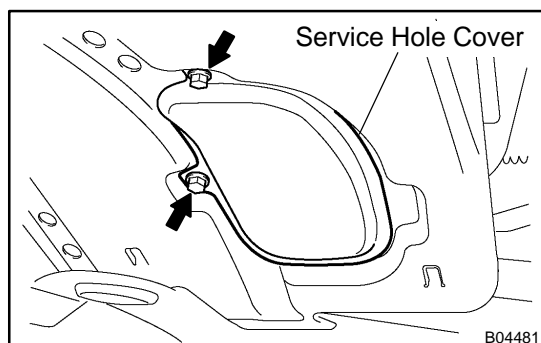

2. REPLACE OIL FILTER

- (a) Remove the 2 bolts and service hole cover.

LUBRICATION - OIL AND FILTER

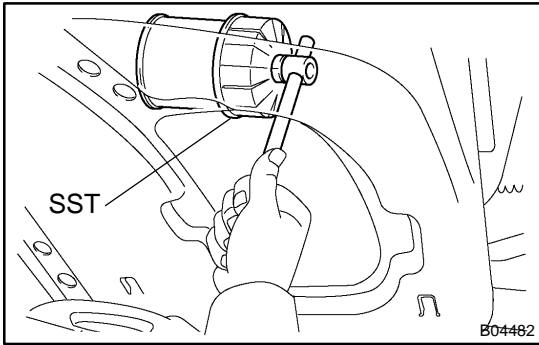

- (b) Using SST, remove the oil filter.
SST 09228-07501
- (c) Clean the oil filter contact surface on the oil filter mounting.
- (d) Lubricate the filter rubber gasket with clean engine oil.

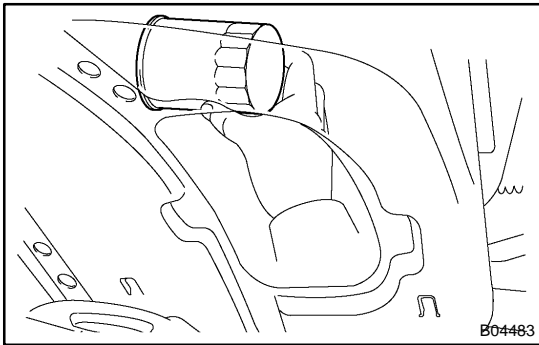

- (e) Tighten the oil filter by hand until the rubber gasket contacts the seat of the filter mounting.

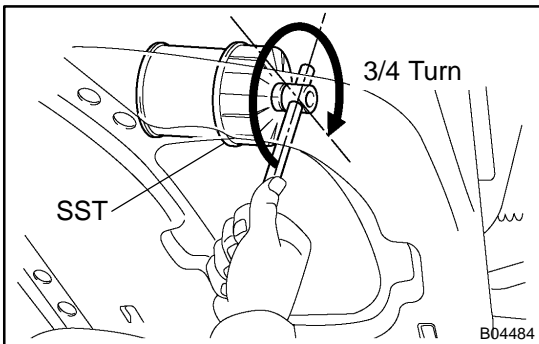

- (f) Using SST, give it an additional 3/4 turn to seat the filter.
SST 09228-07501

3. REFILL WITH ENGINE OIL

- (a) Clean and install the oil drain plug with a new gasket.
Torque: 39 N·m (400 kgf·cm, 29 ft·lbf)

- (b) Fill with new engine oil.

Capacity:

Drain and refill:

w/ Oil filter change: 6.8 liters (7.2 US qts, 6.0 Imp. qts)

w/o Oil filter change: 6.4 liters (6.8 US qts, 5.6 Imp. qts)

Dry fill: 8.0 liters (8.5 US qts, 7.0 Imp. qts)

- (c) Reinstall the oil filler cap.
- 4. START ENGINE AND CHECK FOR ENGINE OIL LEAKS**
- 5. RECHECK ENGINE OIL LEVEL**
- 6. REINSTALL ENGINE UNDER COVER NO.3 AND SERVICE HOLE COVER**

OIL COOLER COMPONENTS

LU08W-08

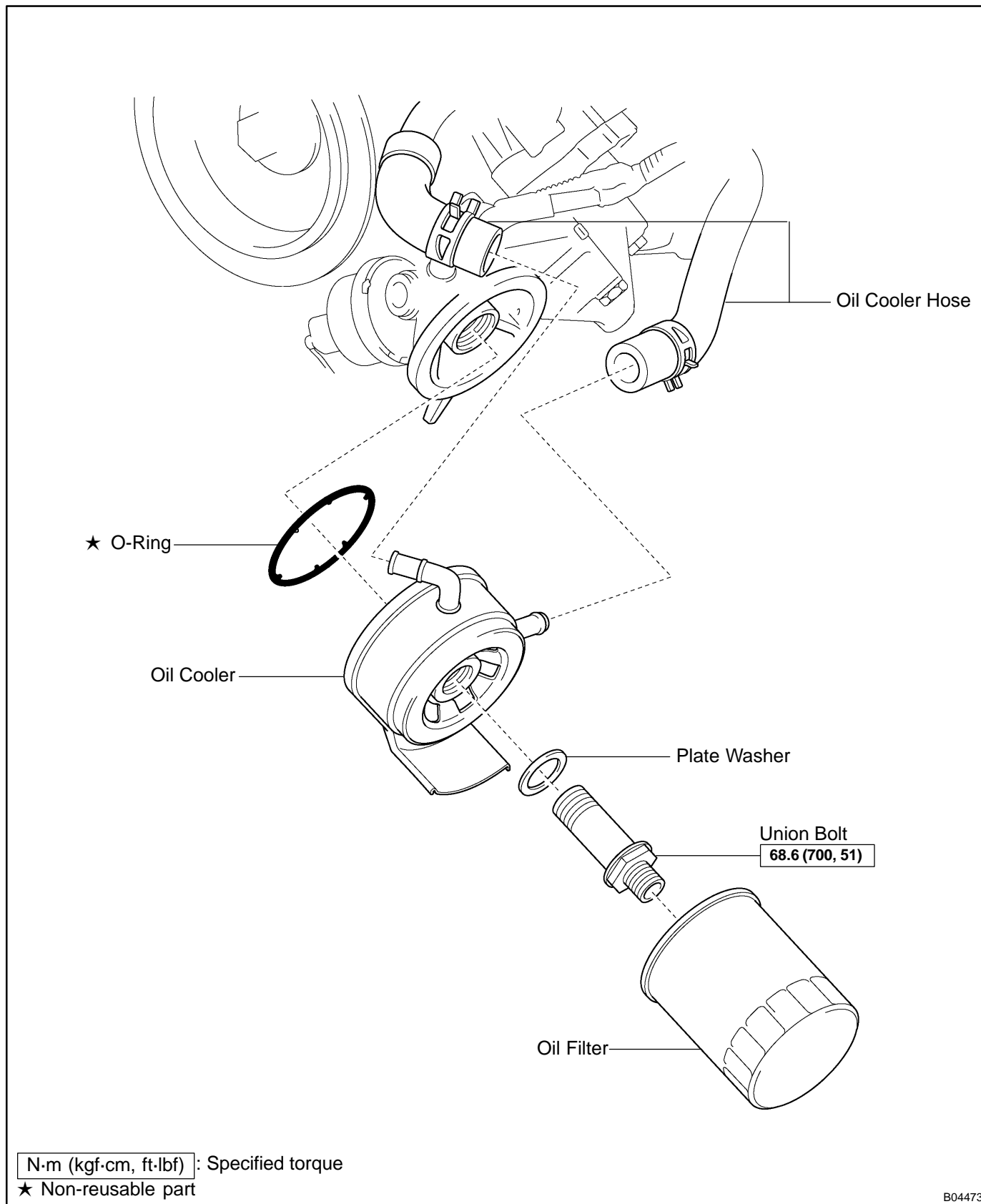

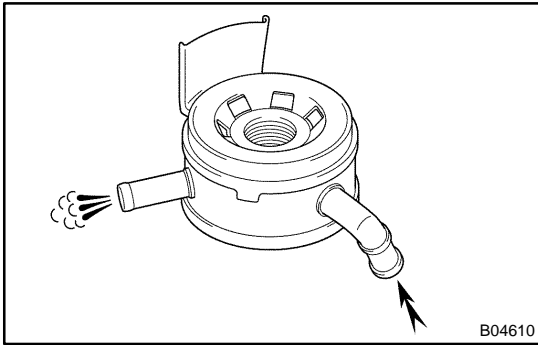

INSPECTION

INSPECT OIL COOLER

Check the oil cooler for damage or clogging.
If necessary, replace the oil cooler.

INSTALLATION

1. INSTALL OIL COOLER

- (a) Clean the oil cooler contact surface on the cooler mounting.

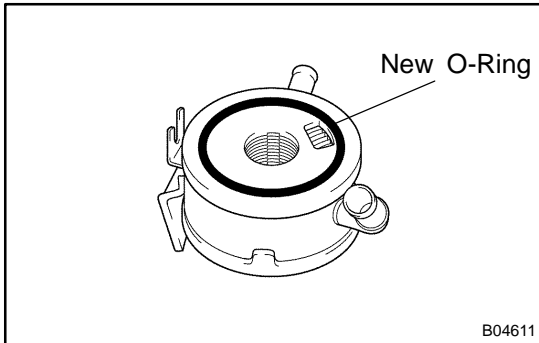

- (b) Install a new O-ring to the oil cooler.
 (c) Apply a light coat of engine oil on the threads and under the head of the union bolt.

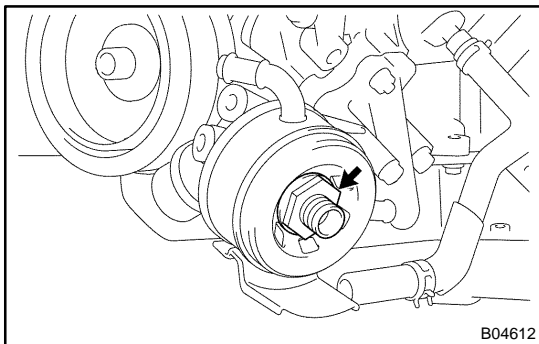

- (d) Install the plate washer and union bolt.
Torque: 68.6 N·m (700 kgf·cm, 51 ft·lbf)
 (e) Connect the 2 oil cooler hoses to the oil cooler.
- 2. INSTALL OIL FILTER (See page LU-2)**
3. FILL WITH ENGINE COOLANT
4. START ENGINE AND CHECK FOR ENGINE OIL LEAKS
5. CHECK ENGINE OIL LEVEL

REMOVAL

1. DRAIN ENGINE COOLANT
2. REMOVE OIL FILTER (See page [LU-2](#))

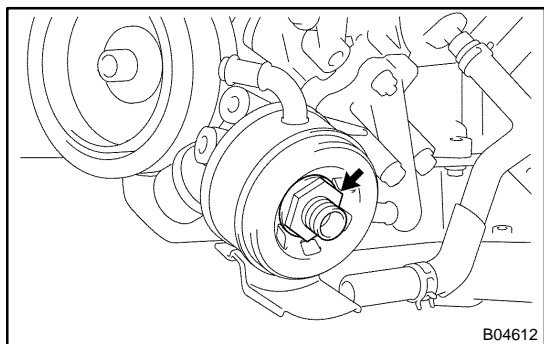

3. REMOVE OIL COOLER
 - (a) Disconnect the 2 oil cooler hoses from the oil cooler.
 - (b) Remove the union bolt, plate washer and the oil cooler.
 - (c) Remove the O-ring from the oil cooler.

OIL PUMP COMPONENTS

LU08P-07

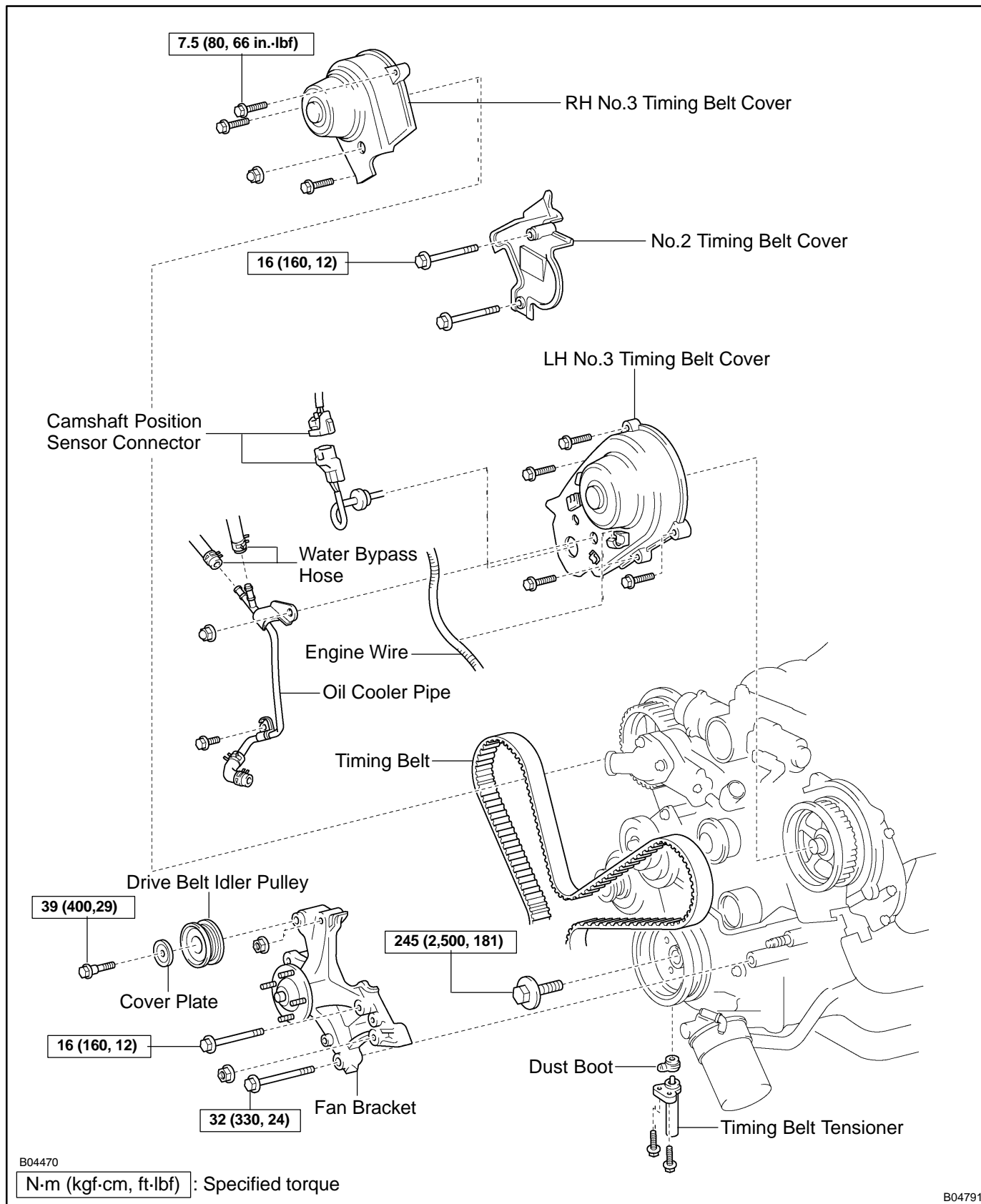

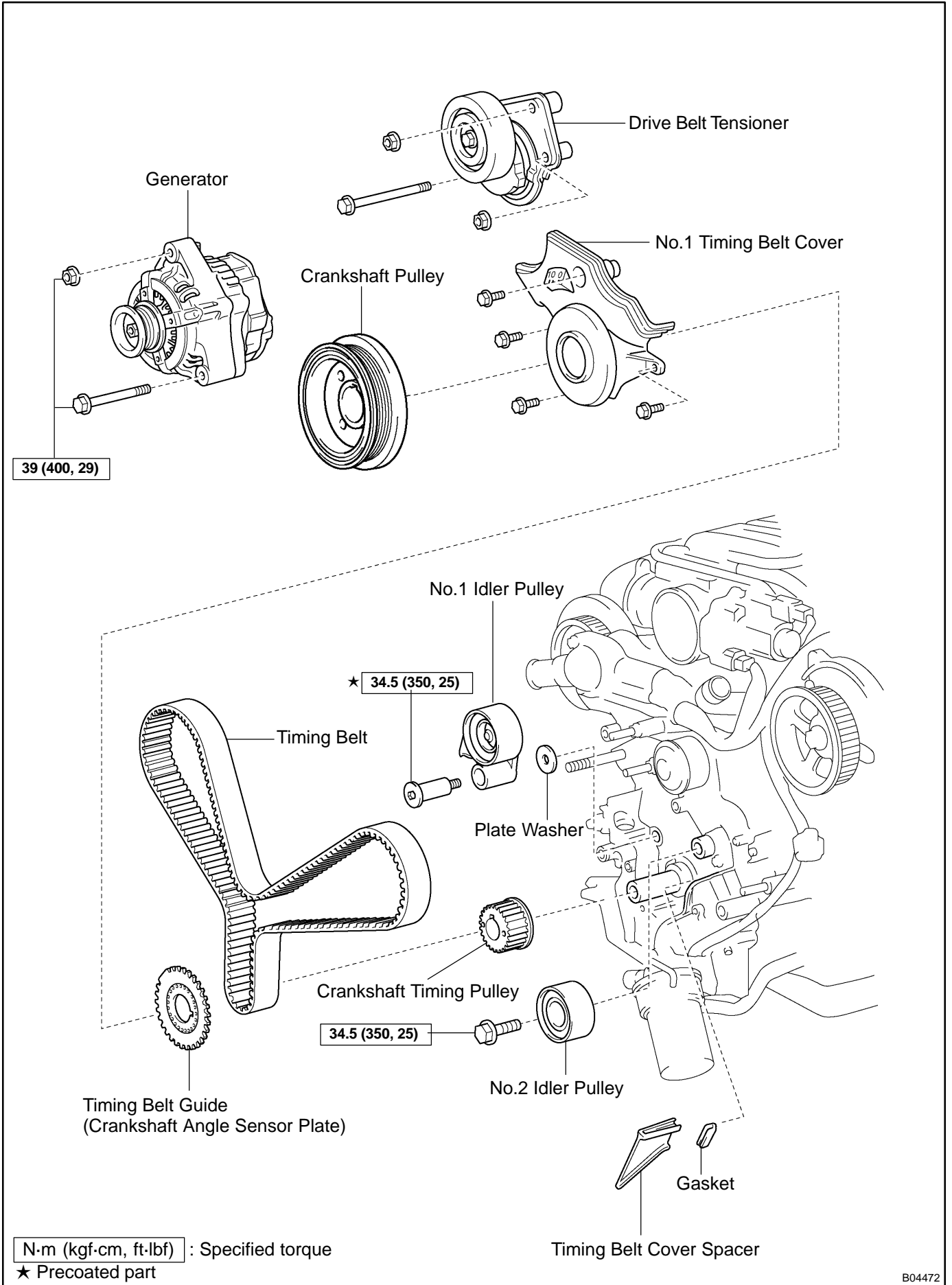

B04472

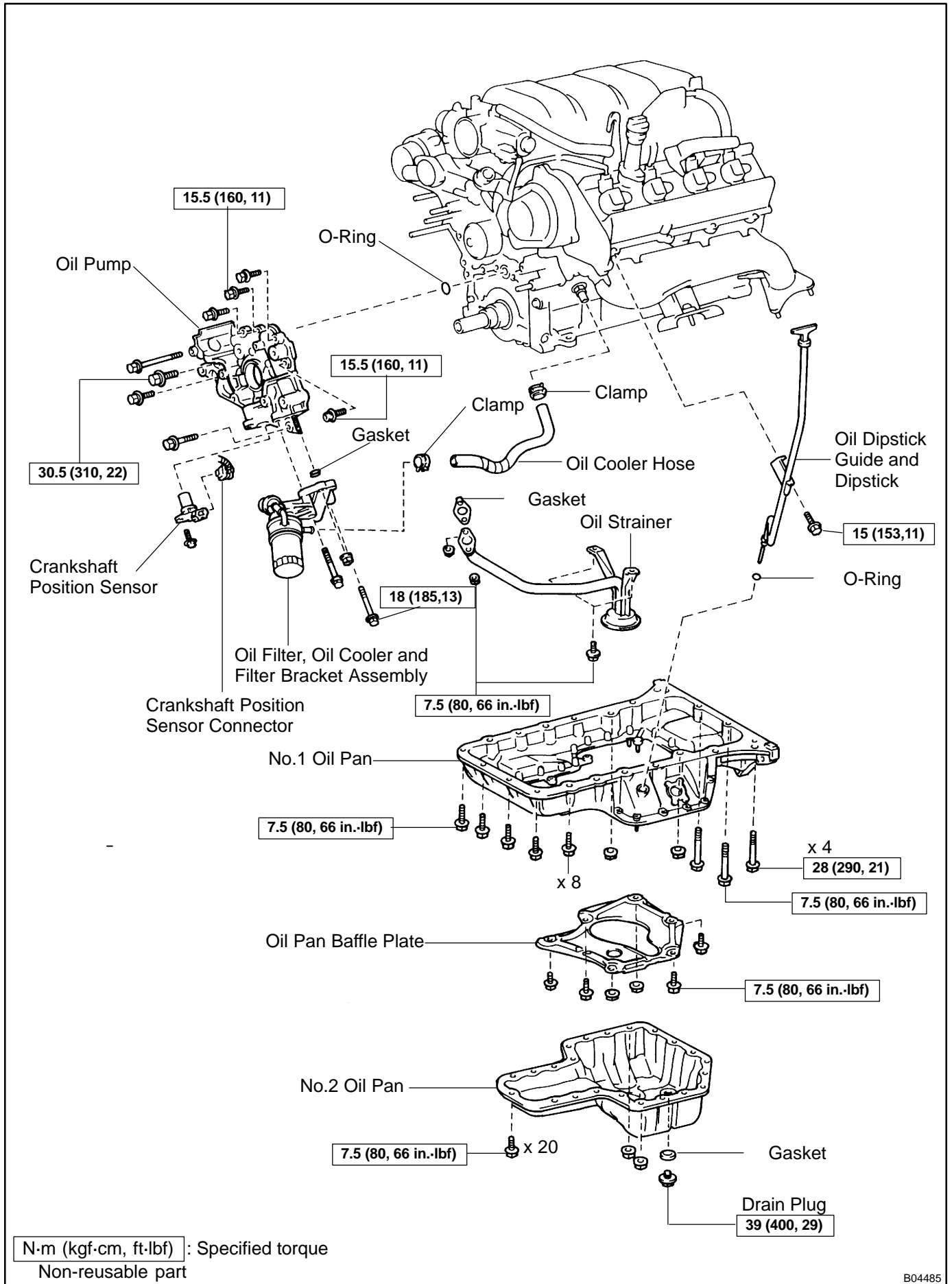

B04485

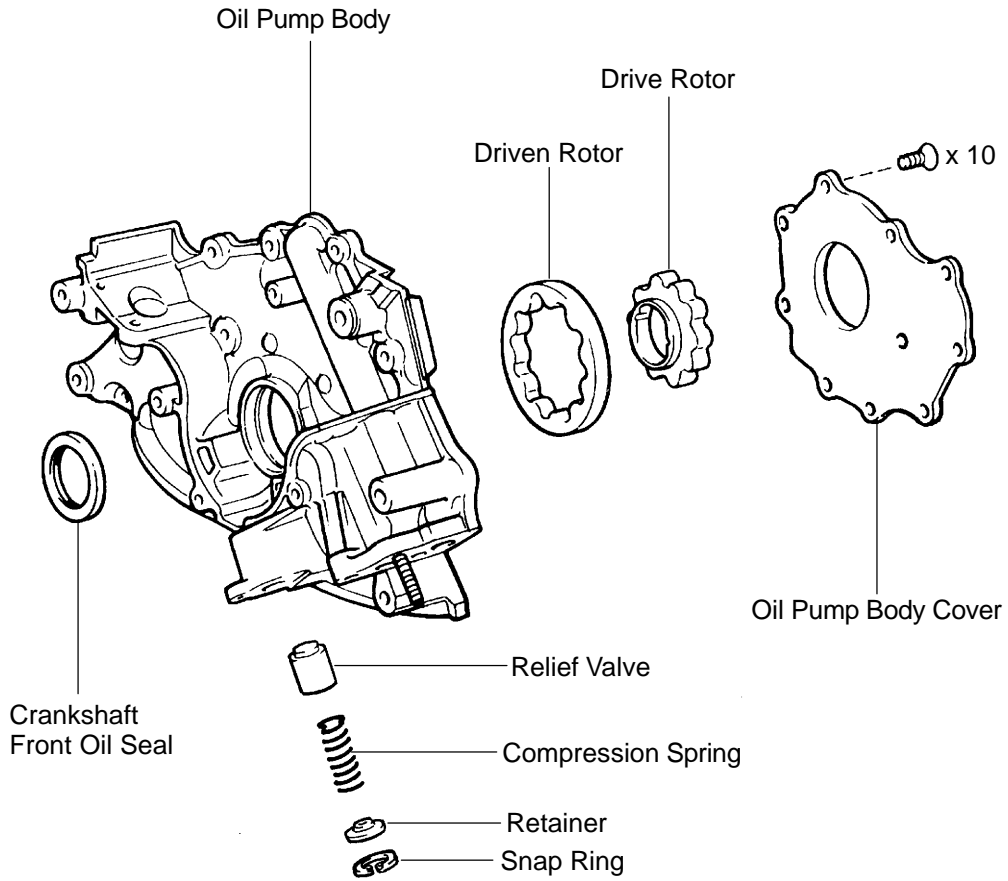

Non-reusable part

B03735

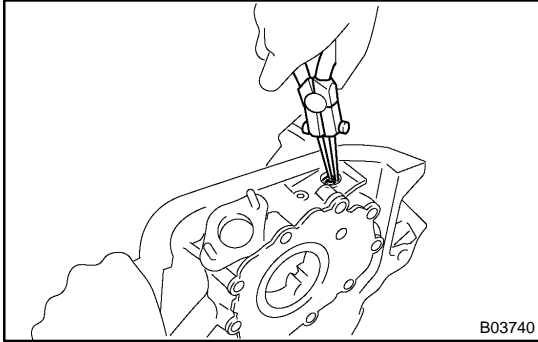

DISASSEMBLY

1. REMOVE RELIEF VALVE

- (a) Using snap ring pliers, remove the snap ring.
- (b) Remove the retainer, spring and relief valve.

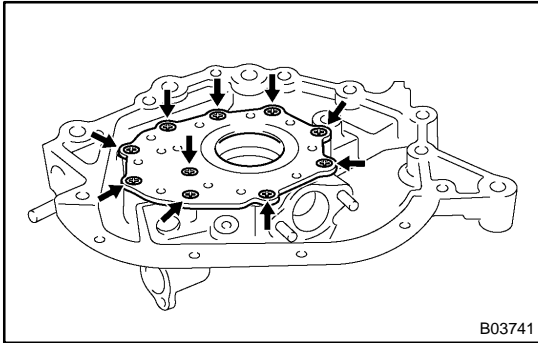

2. REMOVE DRIVE AND DRIVEN ROTORS

Remove the 10 screws, pump body cover, the drive and driven rotors.

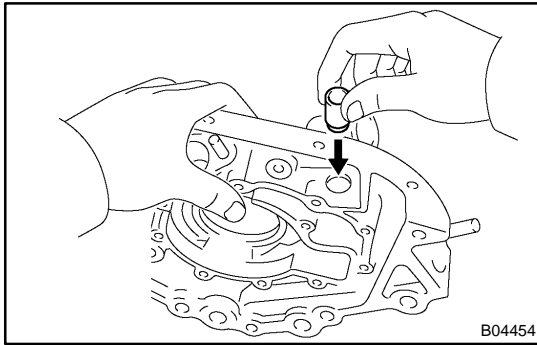

INSPECTION

1. INSPECT RELIEF VALVE

Coat the valve with engine oil and check that it falls smoothly into the valve hole by its own weight.

If it doesn't, replace the relief valve. If necessary, replace the oil pump assembly.

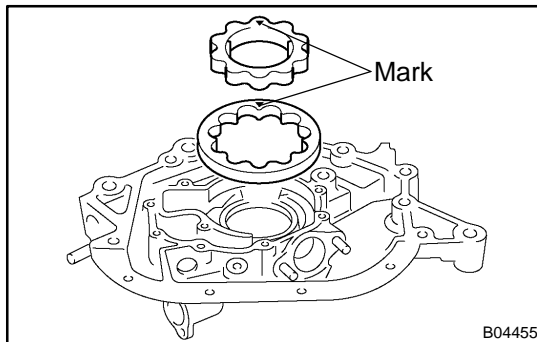

2. INSPECT DRIVE AND DRIVEN ROTORS INTO OIL PUMP BODY

Place the drive and driven rotors into the oil pump body with the mark facing upward.

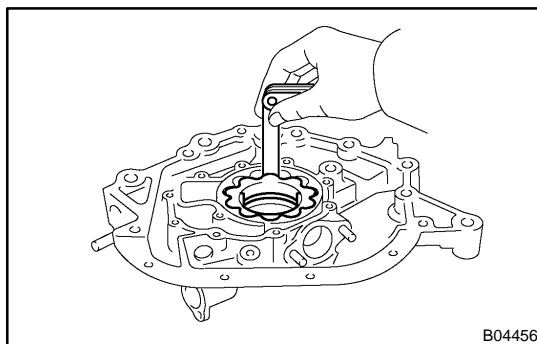

3. INSPECT ROTORS FOR TIP CLEARANCE

Using a feeler gauge, measure the clearance between the drive and driven rotor tips.

Standard tip clearance:

0.110 - 0.240 mm (0.0043 - 0.0094 in.)

Maximum tip clearance: 0.35 mm (0.0138 in.)

If the tip clearance is greater than maximum, replace the rotors as a set.

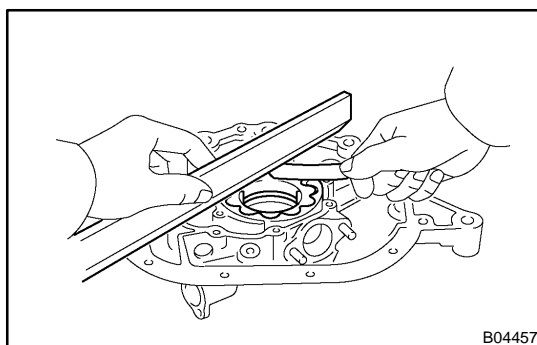

4. INSPECT ROTORS FOR SIDE CLEARANCE

Using a feeler gauge and precision straight edge, measure the clearance between the rotors and precision straight edge.

Standard side clearance:

0.030 - 0.090 mm (0.0012 - 0.0035 in.)

Maximum side clearance: 0.15 mm (0.0059 in.)

If the side clearance is greater than maximum, replace the rotors as a set. If necessary, replace the oil pump assembly.

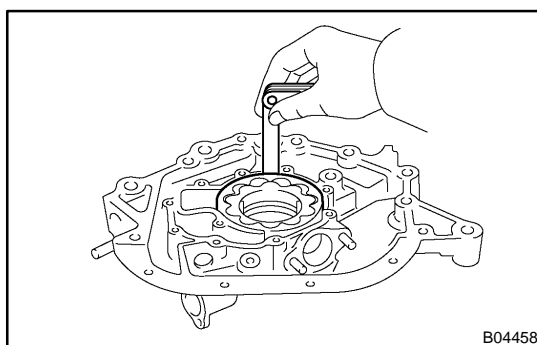

5. INSPECT ROTOR FOR BODY CLEARANCE

Using a feeler gauge, measure the clearance between the driven rotor and body.

Standard body clearance:

0.100 - 0.175 mm (0.0039 - 0.0069 in.)

Maximum body clearance: 0.30 mm (0.0118 in.)

If the body clearance is greater than maximum, replace the rotors as a set. If necessary, replace the oil pump assembly.

6. REMOVE DRIVE AND DRIVE ROTORS

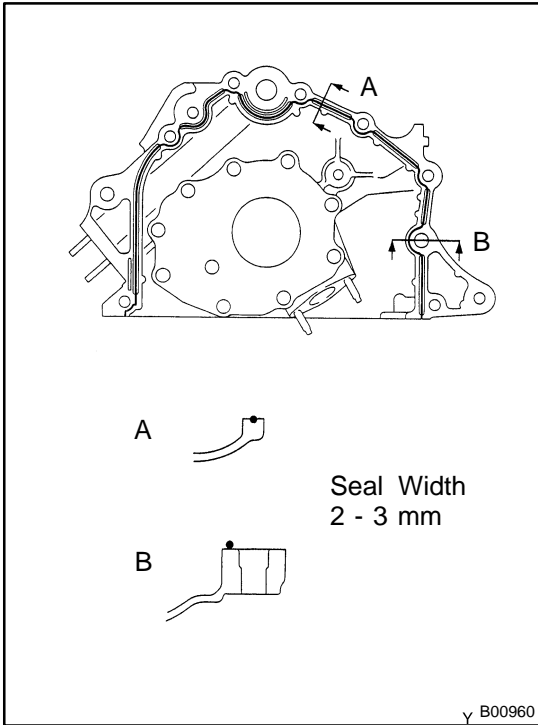

INSTALLATION

1. INSTALL OIL PUMP

- (a) Remove any old packing (FIPG) material and be careful not to drop any oil on the contact surfaces of the oil pump and cylinder block.
 - ★ Using a razor blade and gasket scraper, remove all the old packing (FIPG) material from the gasket surfaces and sealing groove.
 - ★ Thoroughly clean all components to remove all the loose material.
 - ★ Using a non-residue solvent, clean both sealing surfaces.
- (b) Apply seal packing to the oil pump as shown in the illustration.

Seal packing: Part No. 08826-00080 or equivalent

NOTICE:

Avoid applying an excessive amount to the surface. Be particularly careful near oil passage.

- ★ Install a nozzle that has been cut to a 2 - 3 mm (0.08 - 0.12 in.) opening.
- ★ Parts must be assembled within 5 minutes of application. Otherwise the material must be removed and reapplied.
- ★ Immediately remove nozzle from the tube and reinstall cap.

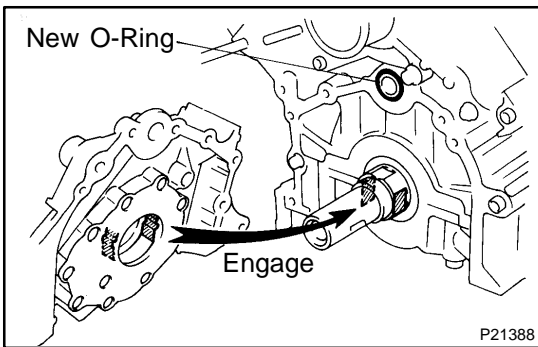

- (c) Install a new O-ring to the cylinder block.
- (d) Engage the spline teeth of the oil pump drive gear with the large teeth of the crankshaft, and slide the oil pump on the crankshaft.

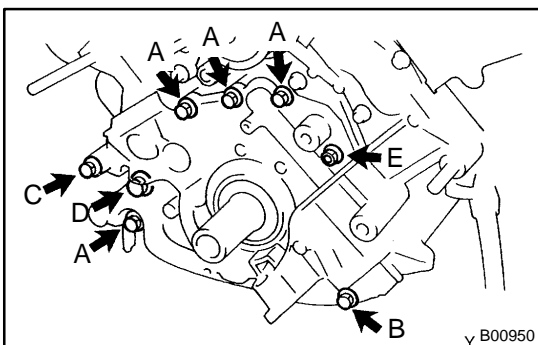

- (e) Install the oil pump with the 8 bolts. Uniformly tighten the bolts in several passes.

Torque:

15.5 N·m (160 kgf·cm, 11 ft·lbf)

for 12 mm head and 6 mm hexagon head

30.5 N·m (310 kgf·cm, 22 ft·lbf) for 14 mm head

HINT:

- ★ Use a 6 mm hexagon wrench for the hexagon head bolt.
- ★ Each bolt length is indicated in the illustration.

Bolt length:
 35 mm (1.38 in.) for A of 12 mm head
 50 mm (1.97 in.) for B of 12 mm head
 106 mm (4.17 in.) for C of 12 mm head
 40 mm (1.57 in.) for D of 14 mm head
 30 mm (1.18 in.) for E of 6 mm hexagon head

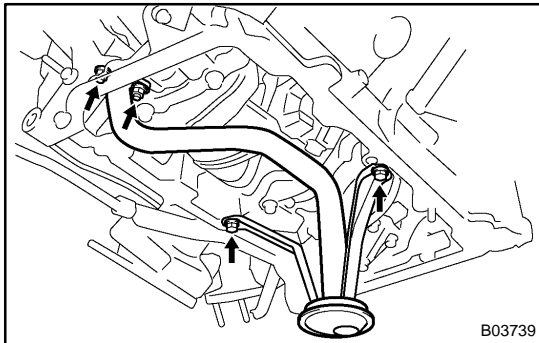

2. INSTALL OIL STRAINER

Install a new gasket and the oil strainer with the 2 bolts and 2 nuts.

Torque: 7.5 N·m (80 kgf·cm, 66 in.-lbf)

HINT:

Use bolt 12 mm (0.47 in.) in length.

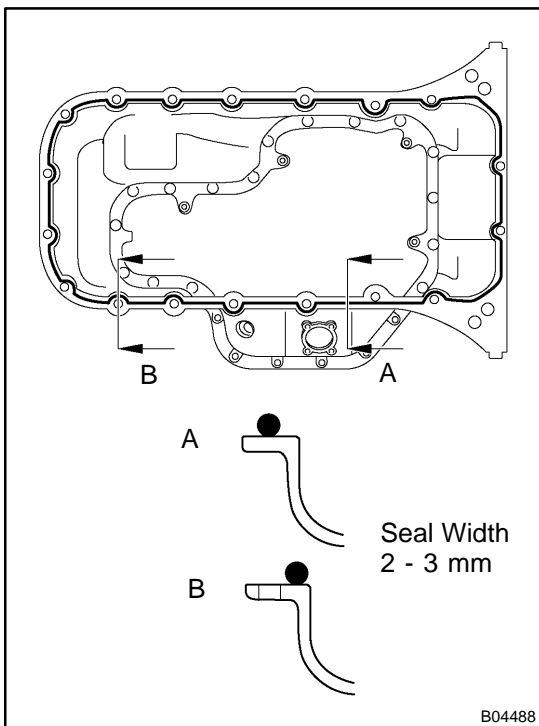

3. INSTALL NO.1 OIL PAN

(a) Remove any old packing (FIPG) material and be careful not to drop any oil on the contact surfaces of the No.1 oil pan, cylinder block, oil pump and rear oil seal retainer.

- ★ Using a razor blade and gasket scraper, remove all the old packing (FIPG) material from the gasket surfaces and sealing groove.
- ★ Thoroughly clean all components to remove all the loose material.
- ★ Using a non-residue solvent, clean both sealing surfaces.

(b) Apply seal packing to the No.1 oil pan as shown in the illustration.

Seal packing: Part No. 08826-00080 or equivalent

- ★ Install a nozzle that has been cut to a 2 - 3 mm (0.08 - 0.12 in.) opening.
- ★ Parts must be assembled within 5 minutes of application. Otherwise the material must be removed and reapplied.
- ★ Immediately remove nozzle from the tube and reinstall cap.

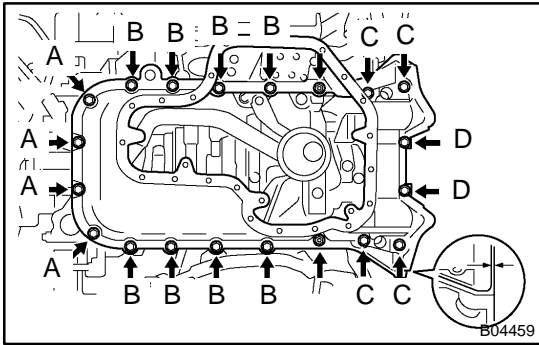

(c) Temporarily install the No.1 oil pan with the 19 bolts, stud bolt and 2 nuts.

HINT:

Each bolt length is indicated in the illustration.

Bolt length:

20 mm (0.79 in.) for A of 10 mm head

25 mm (0.98 in.) for B of 12 mm head

60 mm (2.36 in.) for C of 12 mm head

35 mm (1.38 in.) for D of 10 mm head

(d) Set the No.1 oil pan as shown in the illustration.

NOTICE:

Make sure the clearance between the rear ends of the No.1 oil pan and cylinder block is 0.2 mm (0.008 in.) or less. If the clearance is more than 0.2 mm (0.008 in.), the No.1 oil pan will be stretched.

(e) Uniformly tighten the bolts, and nuts in several passes.

Torque:

7.5 N·m (80 kgf·cm, 66 in.-lbf) for 10 mm head

28 N·m (290 kgf·cm, 21 ft·lbf) for 12 mm head

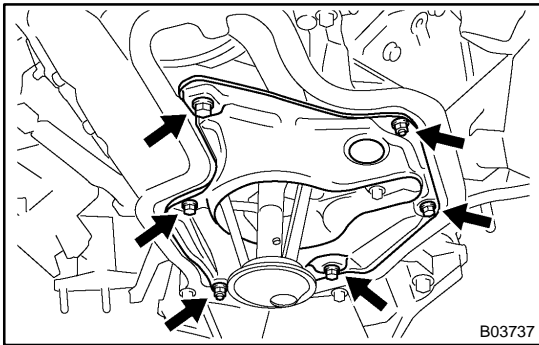

4. INSTALL OIL PAN Baffle PLATE

Install the baffle plate with the 4 bolts and 2 nuts.

Torque: 7.5 N·m (80 kgf·cm, 66 in.-lbf)

HINT:

Use bolts 12 mm (0.55 in.) in length.

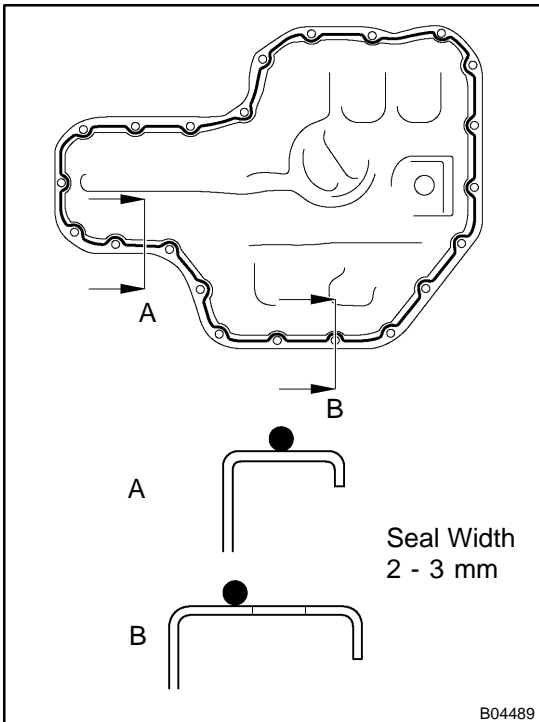

5. INSTALL NO.2 OIL PAN

(a) Remove any old packing (FIPG) material and be careful not to drop any oil on the contact surfaces of the No.1 and No.2 oil pans.

- ★ Using a razor blade and gasket scraper, remove all the old packing (FIPG) material from the gasket surfaces and sealing groove.
- ★ Thoroughly clean all components to remove all the loose material.
- ★ Using a non-residue solvent, clean both sealing surfaces.

NOTICE:

Do not use a solvent which will affect the painted surfaces.

(b) Apply seal packing to the No.2 oil pan as shown in the illustration.

Seal packing: Part No. 08826-00080 or equivalent

- ★ Install a nozzle that has been cut to a 3 - 4 mm (0.12 - 0.16 in.) opening.

- ★ Parts must be assembled within 5 minutes of application. Otherwise the material must be removed and reapplied.
 - ★ Immediately remove nozzle from the tube and reinstall cap.
- (c) Install the No.2 oil pan with the 20 bolts and 2 nuts. Uniformly tighten the bolts and nuts in several passes.
Torque: 7.5 N-m (80 kgf-cm, 66 in.-lbf)

HINT:

Use bolts 14 mm (0.55 in.) in length.

6. INSTALL CRANKSHAFT POSITION SENSOR
(See page [IG-13](#))

7. INSTALL OIL FILTER, OIL COOLER AND FILTER BRACKET ASSEMBLY

- (a) Install the a new gasket to the oil filter bracket.
(b) Install the oil filter, oil cooler and filter bracket assembly with the 2 bolts and nut.

Torque: 18 N-m (185 kgf-cm, 13 ft-lbf)

- (c) Connect the oil pressure switch connector.

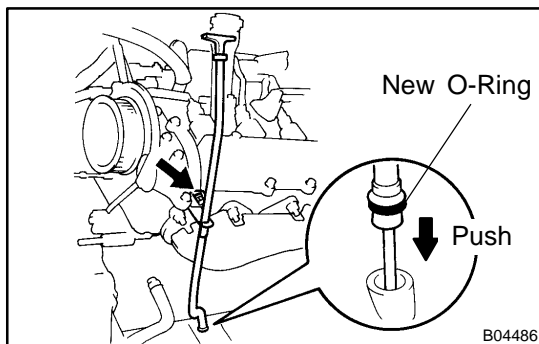

8. INSTALL OIL DIPSTICK GUIDE AND DIPSTICK

- (a) Install a new O-ring to the dipstick guide.
(b) Apply soapy water to the O-ring.
(c) Push in the dipstick guide end into the guide hole of the No.1 oil pan.
(d) Install the dipstick guide with the bolt.
(e) Install the dipstick.

Torque: 15 N-m, (155 kgf-cm, 11 ft-lbf)

9. INSTALL CRANKSHAFT TIMING PULLEY
(See page [EM-22](#))

10. INSTALL NO.1 IDLER PULLEY (See page [EM-22](#))

11. INSTALL NO.2 IDLER PULLEY (See page [EM-22](#))

12. INSTALL TIMING BELT (See page [EM-22](#))

13. DISCONNECT ENGINE FROM ENGINE STAND

14. INSTALL ENGINE TO VEHICLE (See page [EM-81](#))

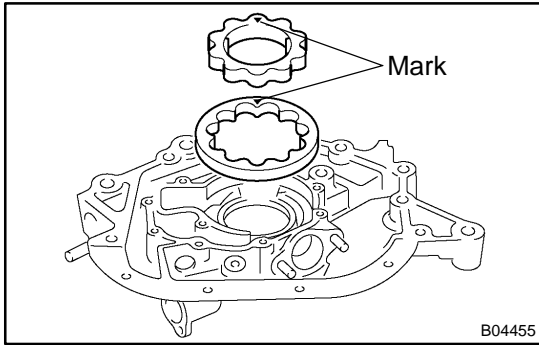

REASSEMBLY

1. INSTALL DRIVE AND DRIVEN ROTORS

- (a) Place the drive and driven rotors into pump body with the marks facing the pump body cover side.

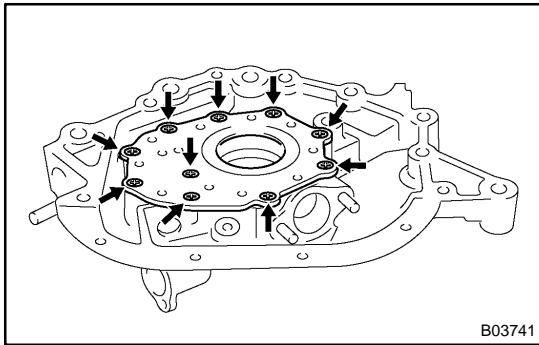

- (b) Install the pump body cover with the 10 screws.
Torque: 10 N·m (105 kgf-cm, 7 ft-lbf)

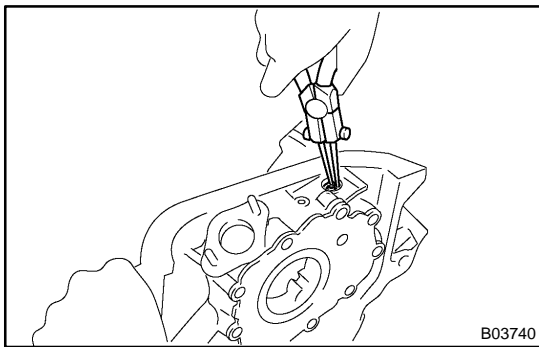

2. INSTALL RELIEF VALVE

- (a) Insert the relief valve, spring and retainer into the oil pump body hole.
- (b) Using snap ring pliers, install the snap ring.

REMOVAL

HINT:

When repairing the oil pump, the oil pan and strainer should be removed and cleaned.

1. **REMOVE ENGINE FROM VEHICLE**
(See page [EM-77](#))
2. **INSTALL ENGINE TO ENGINE STAND FOR DIS-ASSEMBLY**
3. **REMOVE TIMING BELT** (See page [EM-15](#))
4. **REMOVE NO.1 IDLER PULLEY** (See page [EM-15](#))
5. **REMOVE NO.2 IDLER PULLEY** (See page [EM-15](#))
6. **REMOVE CRANKSHAFT TIMING PULLEY**
(See page [EM-15](#))

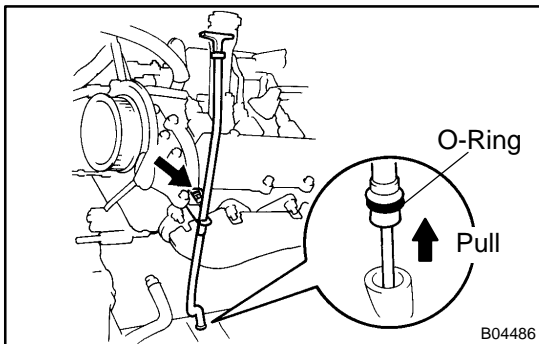

7. **REMOVE OIL DIPSTICK AND GUIDE**
 - (a) Remove the bolt holding the oil dipstick to the LH cylinder head.
 - (b) Pull out the dipstick guide together with the dipstick from the No.1 oil pan.
 - (c) Remove the O-ring from the dipstick guide.

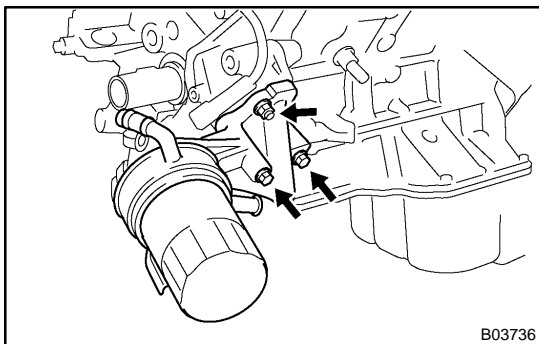

8. **REMOVE OIL FILTER, OIL COOLER AND FILTER BRACKET ASSEMBLY**
 - (a) Disconnect the oil pressure switch connector.
 - (b) Remove the 2 bolts, nut, and oil filter, oil cooler and filter bracket assembly.
 - (c) Remove the gasket from the filter bracket.
9. **REMOVE CRANKSHAFT POSITION SENSOR**
(See page [IG-12](#))

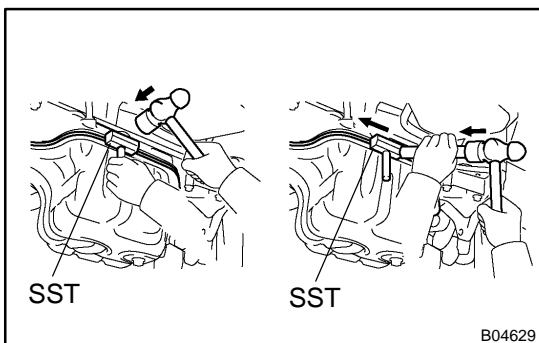

10. **REMOVE NO.2 OIL PAN**
 - (a) Remove the 20 bolts and 2 nuts.
 - (b) Insert the blade of SST between the No.1 and No.2 oil pans, cut off applied sealer and remove the No.2 oil pan.
SST 09032-00100

NOTICE:

- ★ **Be careful not to damage the No.2 oil pan contact surface of the No.1 oil pan.**
- ★ **Be careful not to damage the No.2 oil pan flange.**

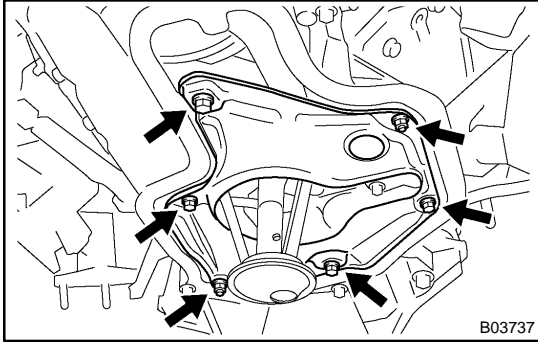

11. REMOVE OIL PAN BAFFLE PLATE
Remove the 4 bolts, 2 nuts and baffle plate.

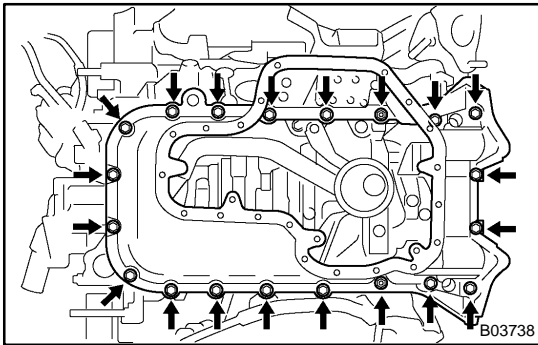

12. REMOVE NO.1 OIL PAN
(a) Remove the 18 bolts and 2 nuts.

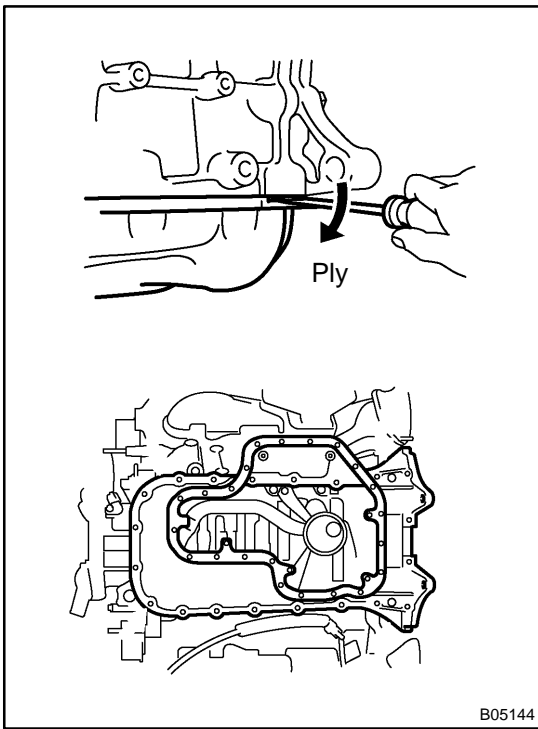

(b) Using a screwdriver, remove the No.1 oil pan by prying between the oil pan and cylinder block in the sequence shown.

NOTICE:

Be careful not to damage the contact surface of the cylinder block and No.1 oil pan.

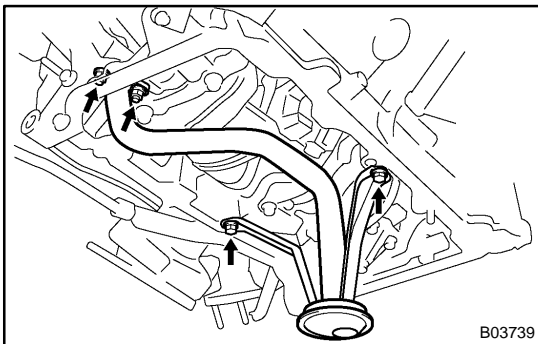

13. REMOVE OIL STRAINER
Remove the 2 bolt, 2 nuts, oil strainer and gasket.

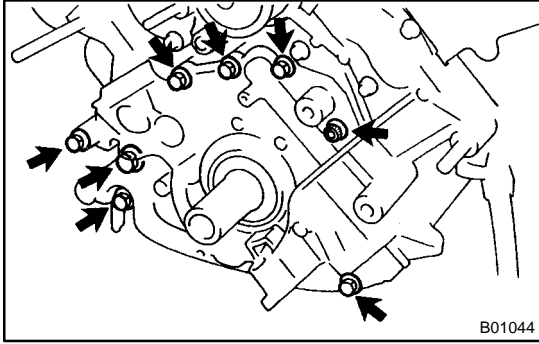

14. REMOVE OIL PUMP

(a) Remove the 8 bolts.

HINT:

Use a 6 mm hexagon wrench for the hexagon head bolt.

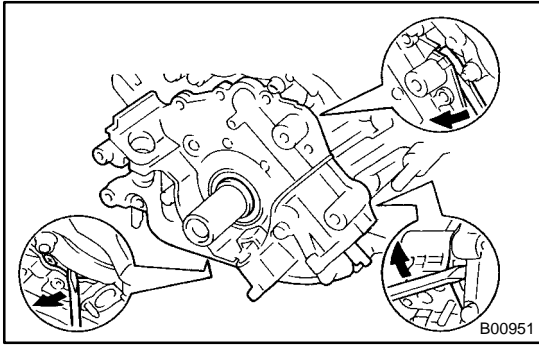

(b) Using a screwdriver, remove the oil pump by prying the portions between the oil pump and cylinder block.

NOTICE:

Be careful not to damage the contact surface of the cylinder block and oil pump.

(c) Remove the O-ring from the cylinder block.

REPLACEMENT

REPLACE CRANKSHAFT FRONT OIL SEAL (See page [EM-104](#))