

DENSO

Diesel Injection Pump

SERVICE MANUAL

**TOYOTA NEW LAND CRUISER 70
1VD-FTV ENGINE
COMMON RAIL SYSTEM (CRS)
OPERATION**

March, 2007

DENSO CORPORATION

00400595E

© 2007 DENSO CORPORATION

All Rights Reserved. This book may not be reproduced or copied, in whole or in part, without the written permission of the publisher.

Operation Section

1. APPLICABLE VEHICLE and PRODUCT INFORMATION

1.1	Introduction	1-1
1.2	Applicable Vehicle	1-1
1.3	Layout of Main Components	1-2
1.4	Applicable Product List	1-3
1.5	CRS Construction	1-3

2. SUPPLY PUMP

2.1	Outline	1-4
2.2	Suction Control Valve (SCV)	1-5

3. RAIL

3.1	Outline	1-6
-----	-------------------	-----

4. INJECTOR

4.1	Outline	1-7
-----	-------------------	-----

5. CONTROL SYSTEM

5.1	Control System Diagram	1-8
5.2	Engine ECU (Electronic Control Unit)	1-9
5.3	EDU	1-9
5.4	Sensors	1-10
5.5	Exhaust Gas Recirculation (EGR) Valve	1-12

6. FUEL INJECTION CONTROL

6.1	Outline	1-13
6.2	Injection Pattern	1-13

7. ENGINE ECU DIAGNOSTIC TROUBLE CODES (DTC)

7.1	DTC Table	1-14
7.2	Fail-Safe Table	1-20

8. ATTACHED MATERIALS

8.1	Engine ECU External Wiring Diagram	1-24
8.2	Connector Terminal Layout	1-26

1. APPLICABLE VEHICLE and PRODUCT INFORMATION

1.1 Introduction

- As a result of a model change, TOYOTA's first V-8 engine, the "1VD-FTV" is installed in the TOYOTA LAND CRUISER 70. This manual describes the Common Rail System (CRS) installed on the LAND CRUISER 70 1VD-FTV engine. For common information to all CRSs, refer to the previously published CRS general addition manual (Doc ID: 00400076E). [Items common to all CRSs: CRS development process, system control, construction and operation of main components (supply pump, rail, injectors.)]

1.2 Applicable Vehicle

Vehicle Name	Vehicle Model	Engine Model	Engine Displacement	Destination	Release Date
LAND CRUISER 70	VDJ76, 78, 79	1VD-FTV	4.5L	Australia	January, 2007.



Q002238E

1.3 Layout of Main Components

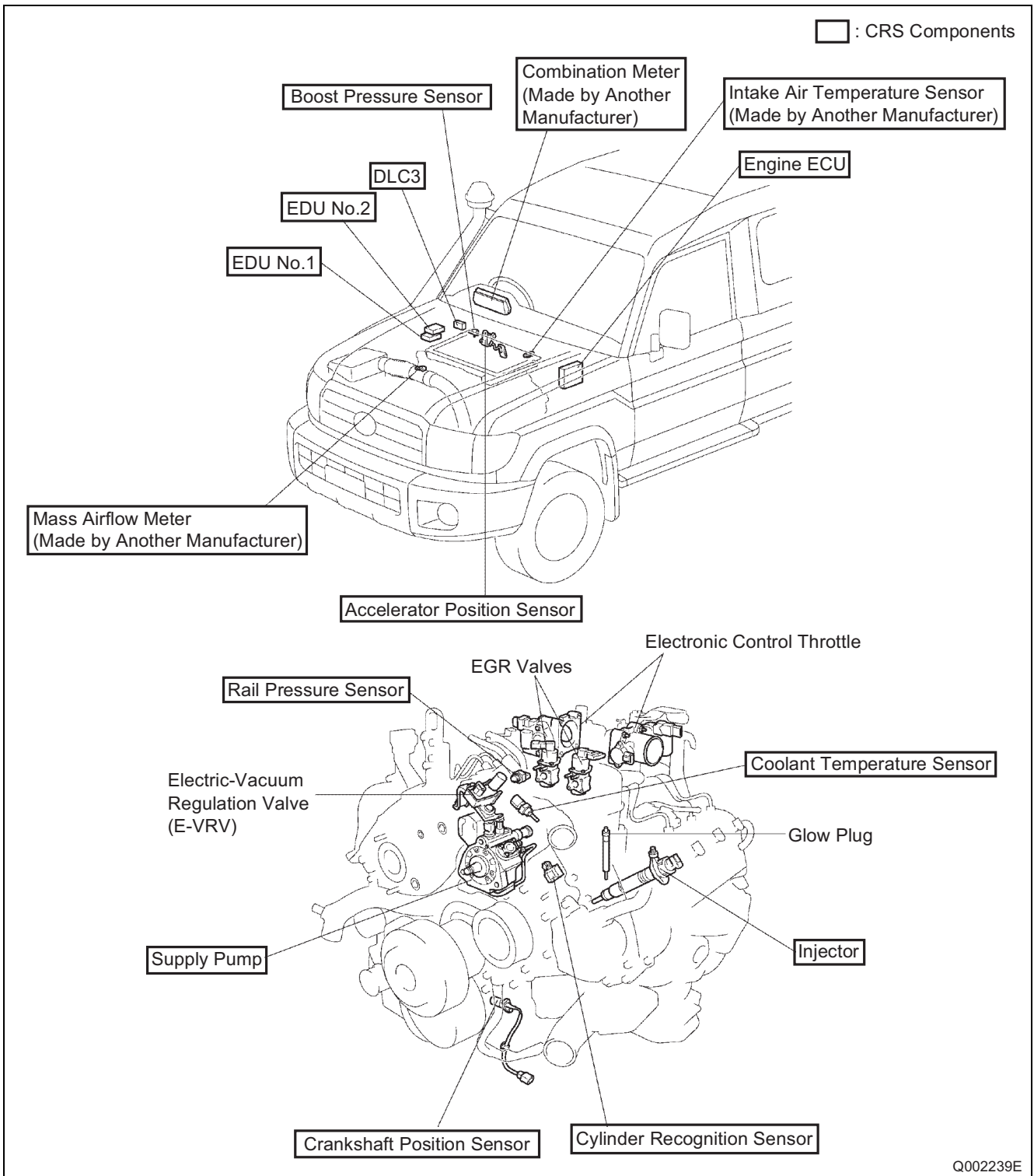

< NOTE >

- The E-VRV, EGR valves, electronic control throttle, and glow plug are devices related to engine control.
- All products are made by DENSO with the exception of the combination meter, intake air temperature sensor, and Mass Airflow Meter (AFM.)

1.4 Applicable Product List

Parts Name	DENSO Part Number	Manufacturer Part Number	Remarks
Supply Pump	294050-018#	22100-51020	HP4
Injector	095000-674#	23670-51010	8 injectors
Rail	HU095440-100#	23810-0W010	RH
	HU095440-104#	23820-0W010	LH
Engine ECU	275900-001#	89661-60F30	
EDU	101310-578#	89870-60070	2 EDUs
Crankshaft Position Sensor	029600-074#	90919-05029	
Cylinder Recognition Sensor	029600-149#	90919-05072	
Coolant Temperature Sensor	071560-005#	89422-16010	
Accelerator Pedal Module	198800-359#	78120-60410	
EGR Valve No.1	135000-727#	23620-51010	RH
EGR Valve No.2	135000-728#	25630-51010	LH

1.5 CRS Construction

- The illustration below is an outline of the CRS. The primary feature of this system is the use of two rails and two EDUs in order to comply with the V-8 engine. When looking into the engine compartment from the driver's seat, the two rails are positioned above the right and left banks (hereafter: right bank rail = "rail RH", left bank rail = "rail LH"). EDU No.1 and No.2 each control four injectors.

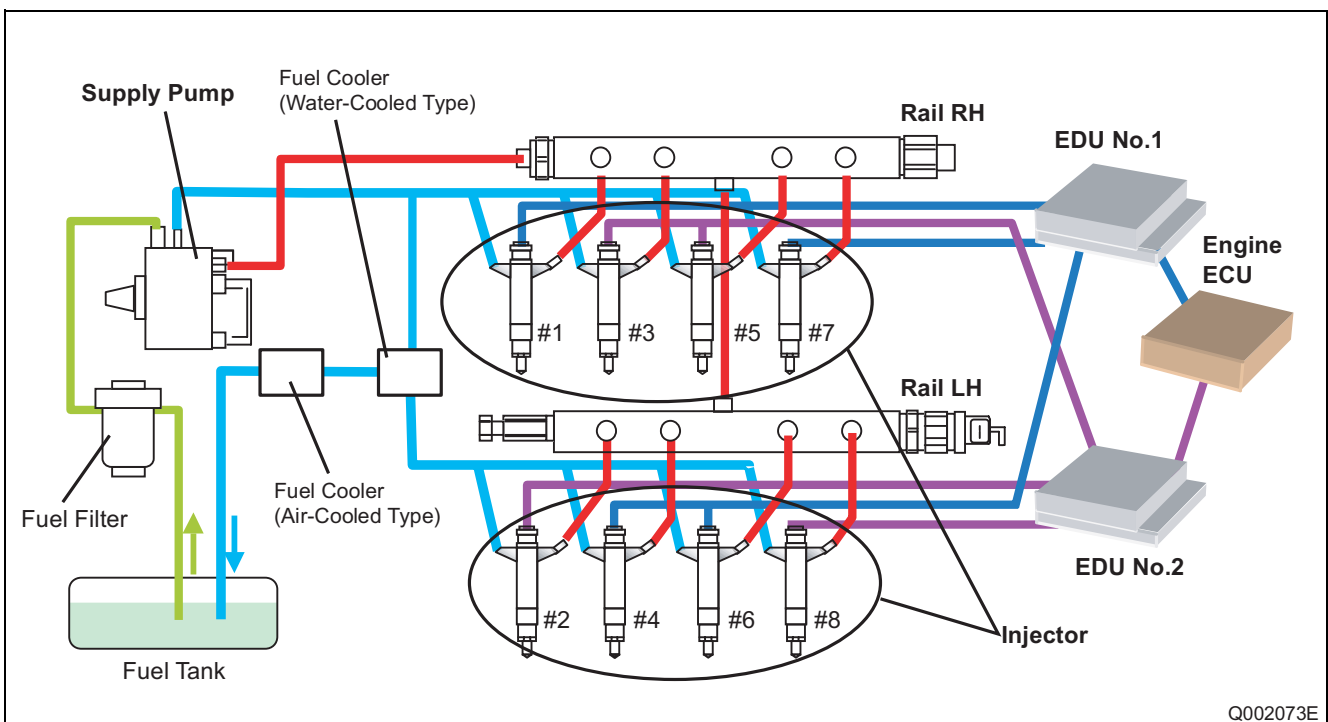

Q002073E

2. SUPPLY PUMP

2.1 Outline

- The CRS used in the TOYOTA LANDCRUISER 70 is equipped with an HP4 supply pump.
- The supply pump is equipped with a compact Suction Control Valve (SCV). The SCV is a normally closed control type.

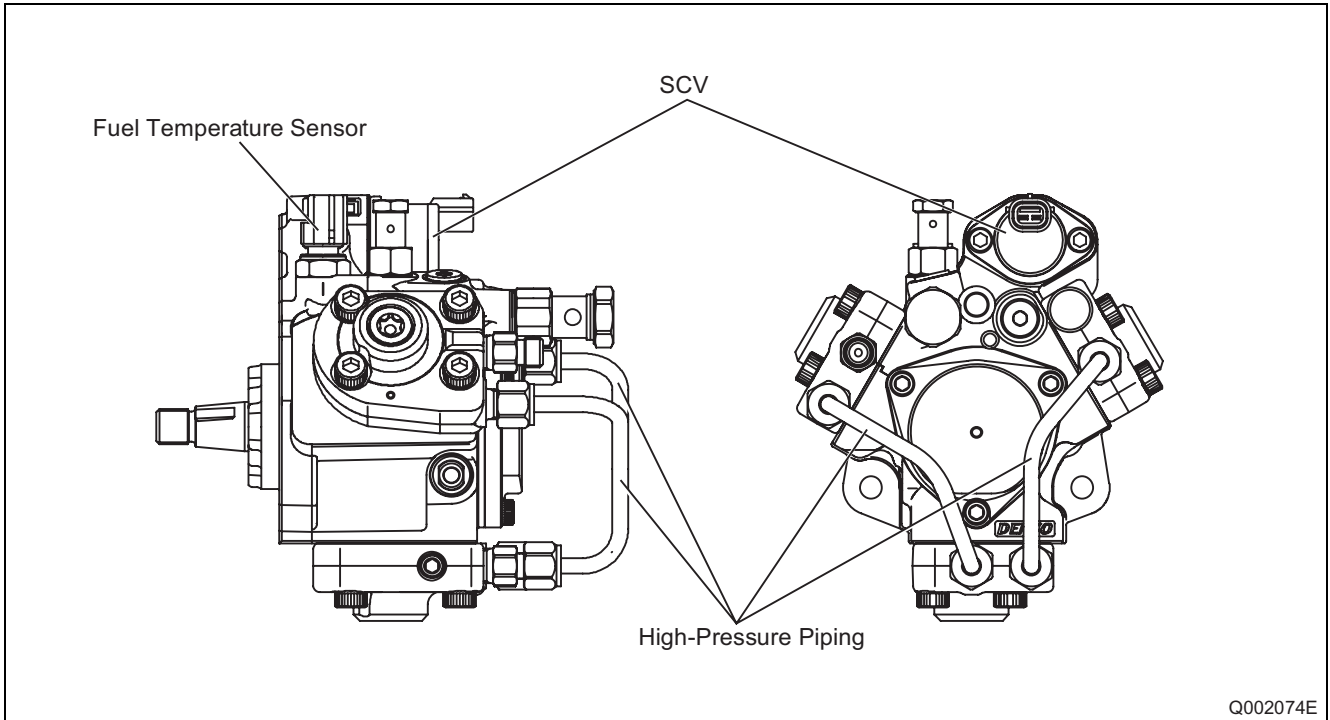

Supply Pump Specifications

Item	Content
Part Number	294050-018#
Pump Type	HP4 Supply pump
Rotation	Clockwise viewed from drive side
SCV Terminal Resistance	2.10 ± 0.15 Ω (20 °C) 12 V

2.2 Suction Control Valve (SCV)

- The CRS used in the TOYOTA LANDCRUISER 70 is equipped with a compact SCV. The SCV is a normally closed type.

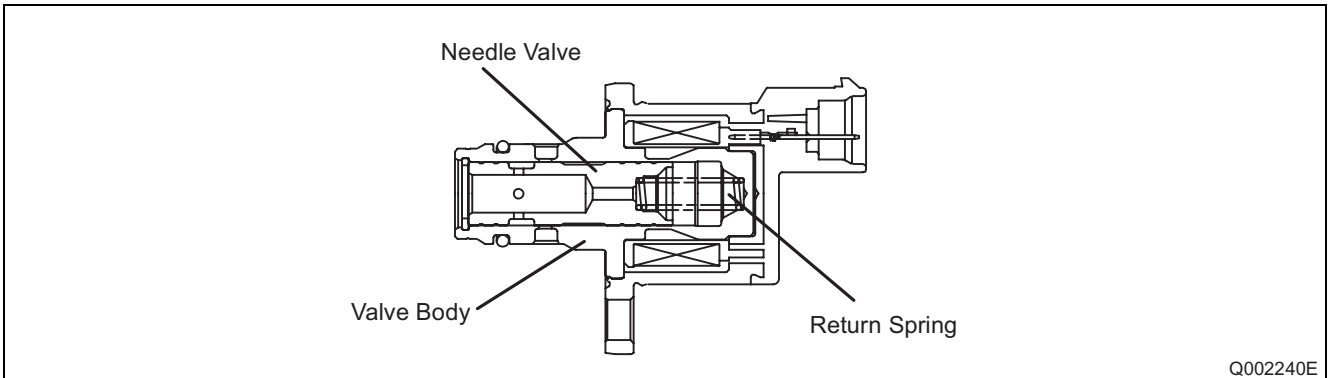

Operation Concept Diagram

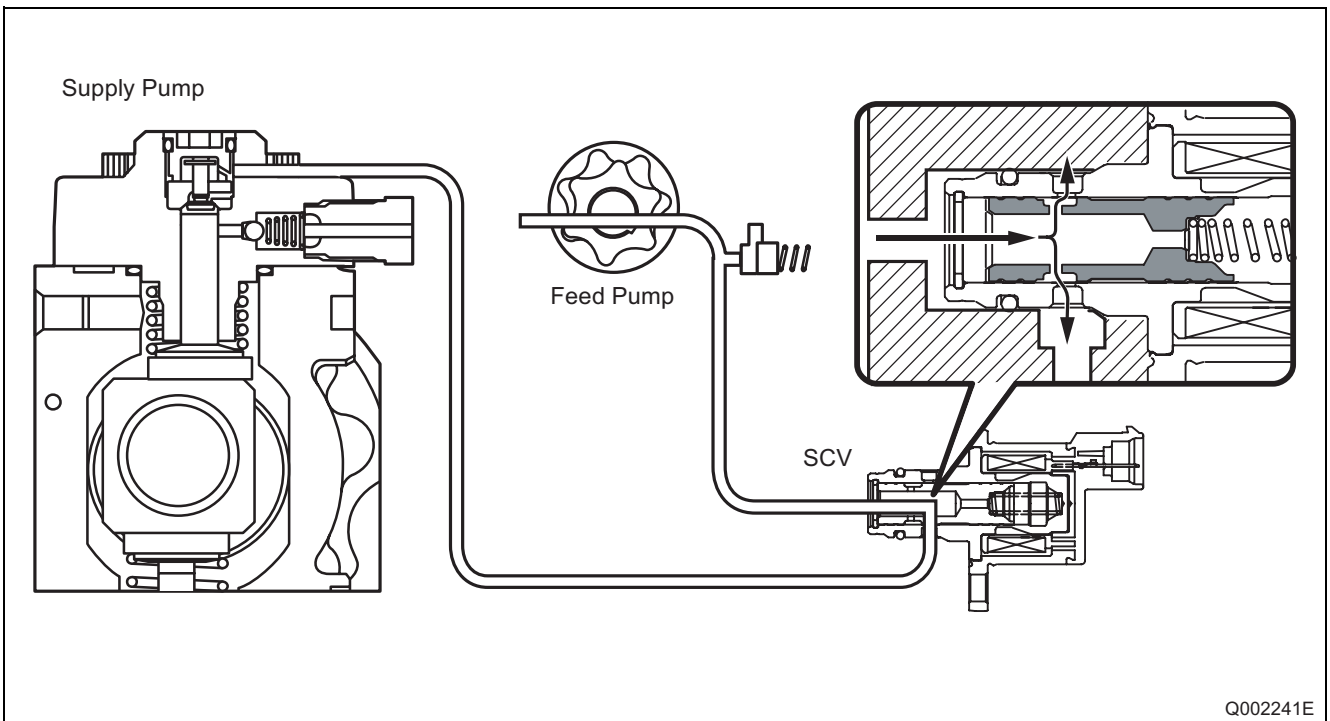

Operation

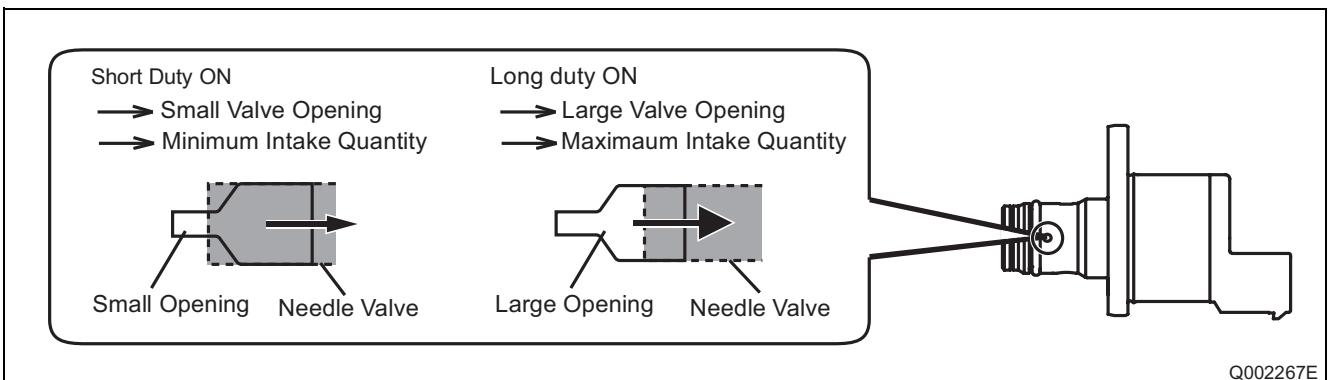

3. RAIL

3.1 Outline

- Rail RH is provided with a fuel inlet to connect rail RH to rail LH. Rail internal fuel pressure is controlled by a rail pressure sensor (Pc sensor) attached to rail RH, and the engine ECU. In addition, when rail internal pressure becomes abnormally high, a pressure limiter attached to rail LH opens to release excess pressure.

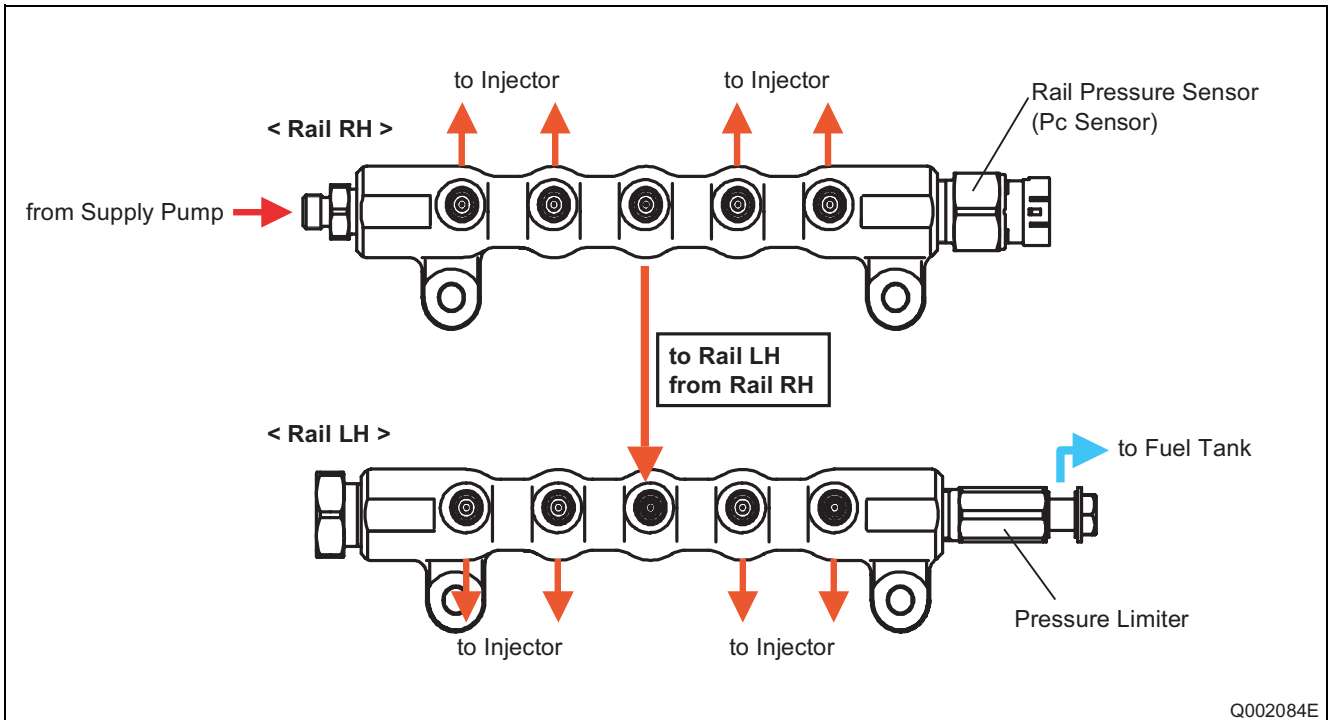

4. INJECTOR

4.1 Outline

- The CRS used in the TOYOTA LANDCRUISER 70 is equipped with eight solenoid injectors with QR codes, as shown in the figure below.

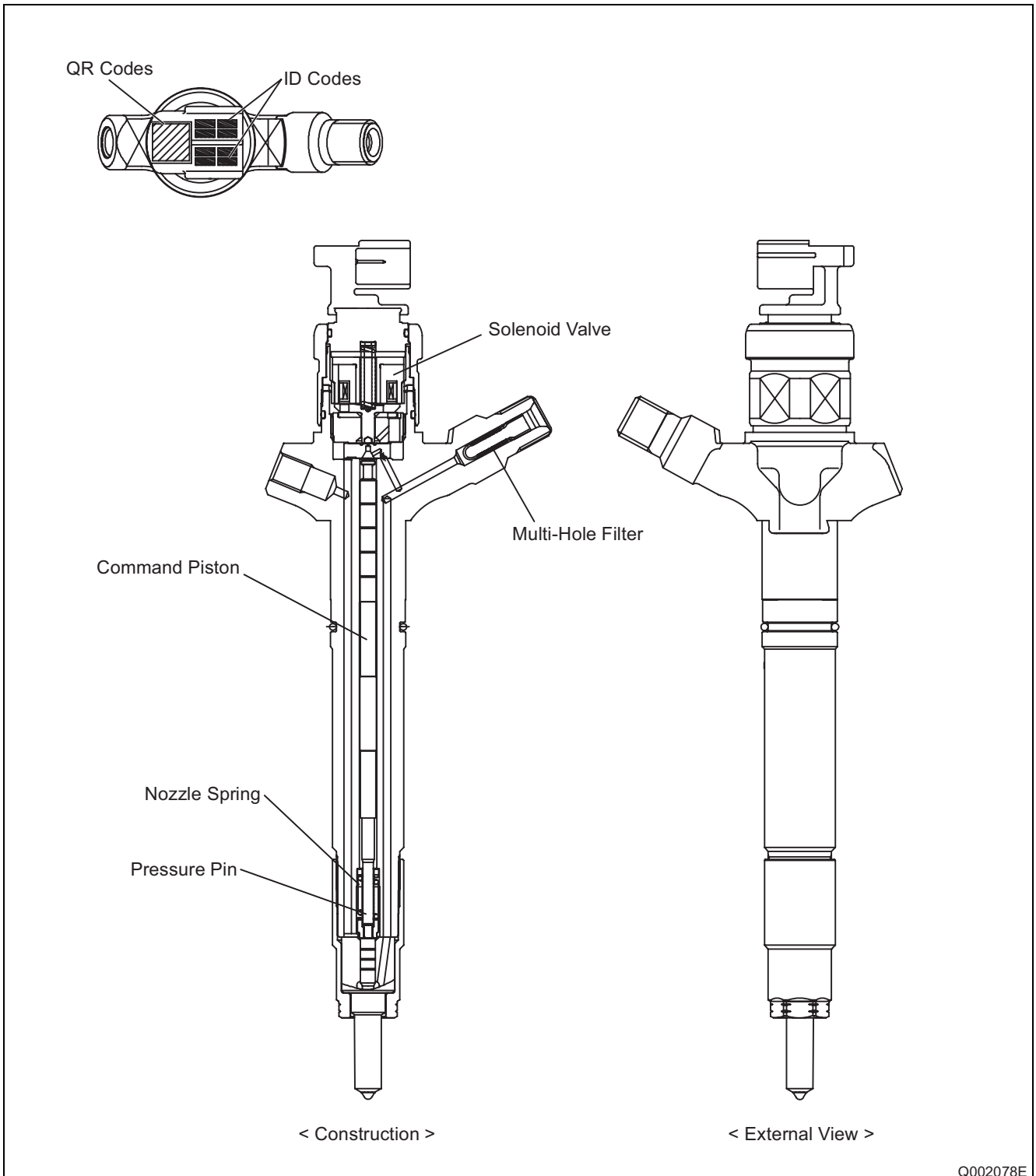

5. CONTROL SYSTEM

5.1 Control System Diagram

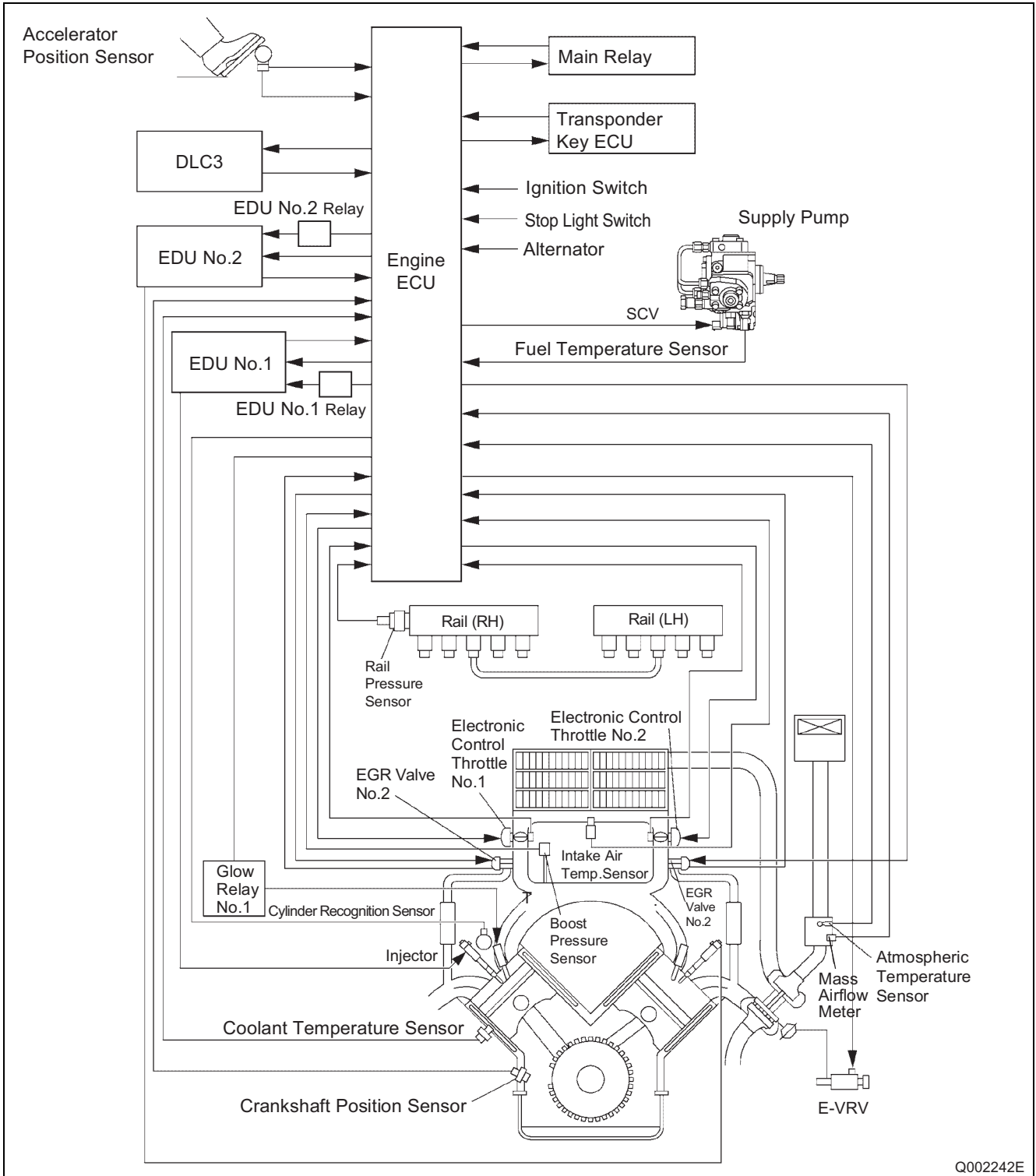

5.2 Engine ECU (Electronic Control Unit)

- The figure below is an external view of the engine ECU. For details on the connector terminal layout, refer to "8.2 Connector Terminal Layout".

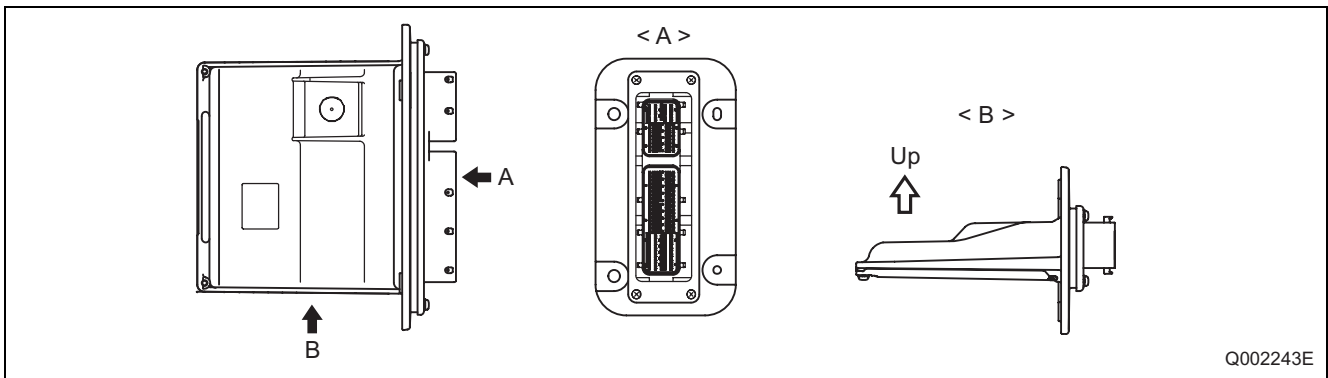

5.3 EDU

- The CRS for the TOYOTA LANDCRUISER 70 uses two EDUs (No.1 and No.2). Control of the eight injectors is divided into two systems. EDU No.1 controls cylinders 1, 4, 6, and 7, while EDU No.2 controls cylinders 2, 3, 5, and 8. The following page displays a circuit diagram for one system.

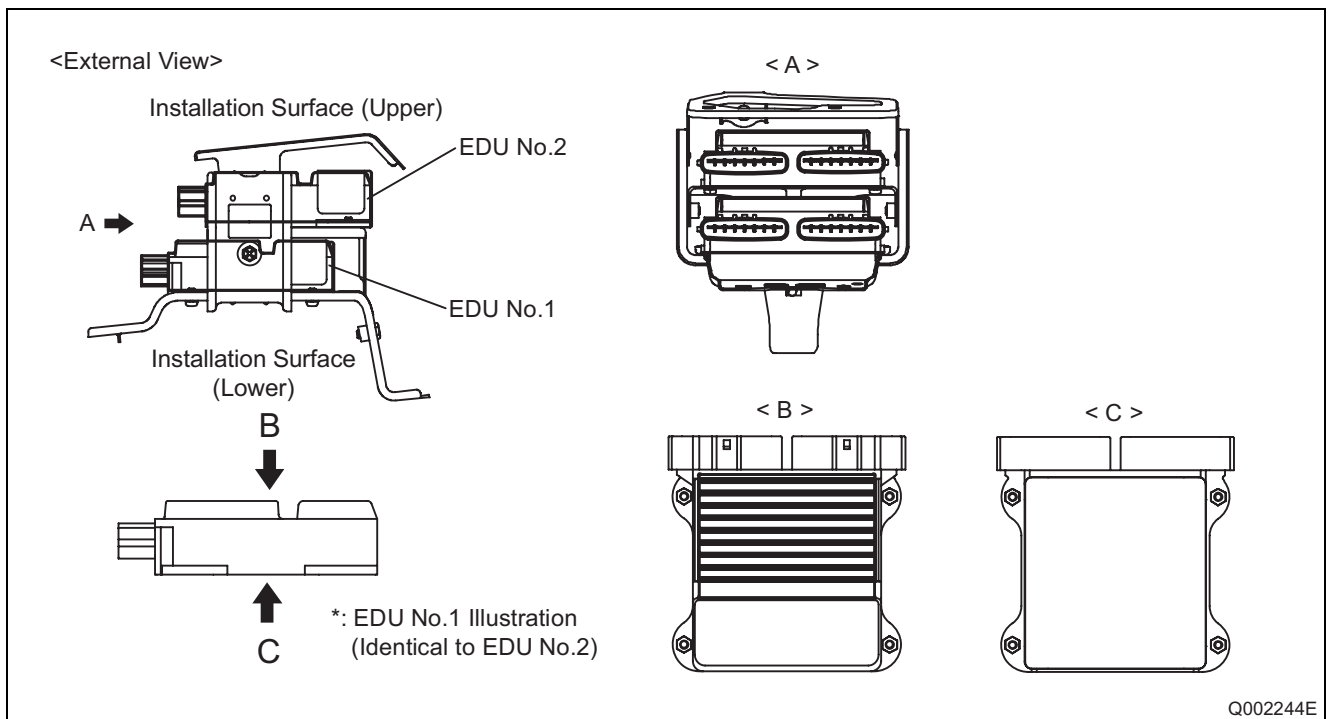

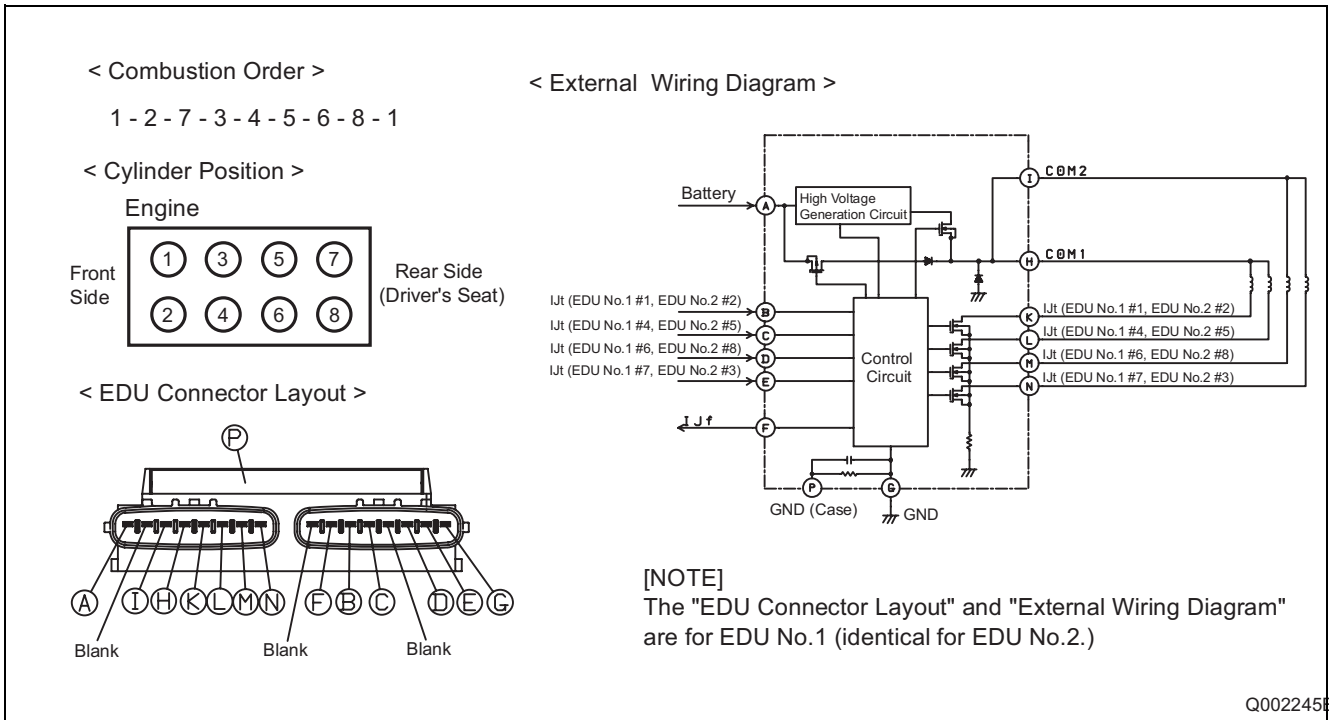

5.4 Sensors

(1) Crankshaft Position Sensor

- The crankshaft position sensor is a Magnetic Pick Up (MPU) type sensor. The crankshaft position sensor is attached to the crankshaft timing gear, and detects NE pulses according to the number of timing gear teeth. There are 34 timing gear teeth plus two missing teeth. When the two missing teeth pass the crankshaft position sensor, Top Dead Center (TDC) is accurately detected due to the pulse change.

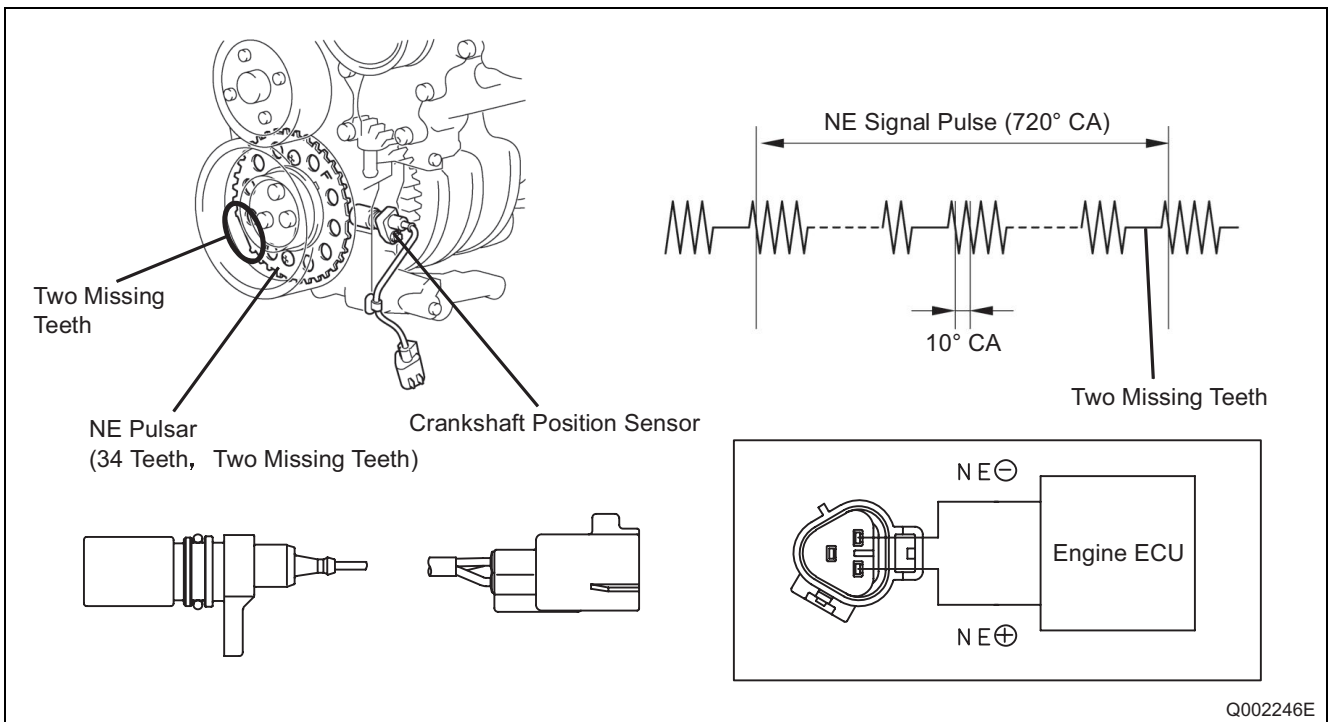

(2) Cylinder Recognition Sensor

- The cylinder recognition sensor is a Magnetic Pick Up (MPU) type sensor. The cylinder recognition sensor is attached to the camshaft timing gear. When the protrusion on the timing gear (G pulsar) passes the sensor, cylinder recognition is performed according to the pulse change.

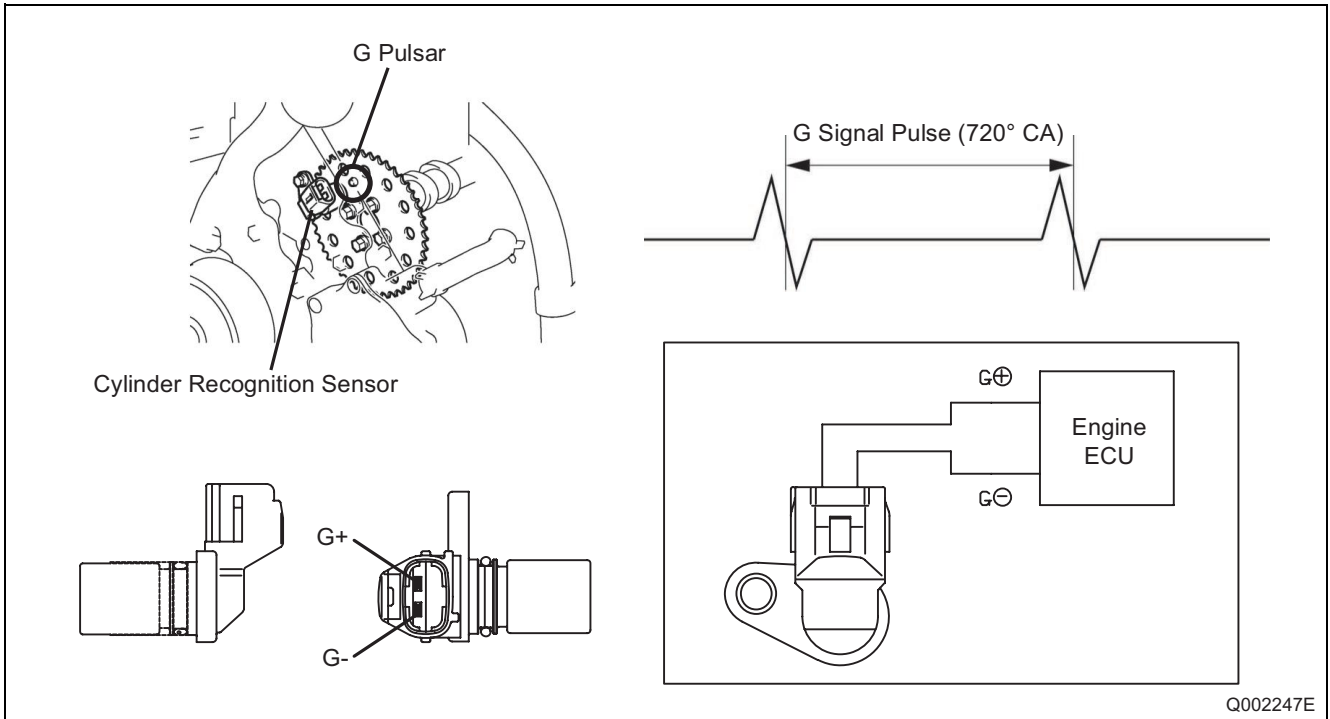

(3) Accelerator Position Sensor (Accelerator Pedal Module)

- The accelerator position sensor is a hall element type sensor. Accelerator position is converted to an electrical signal that is output to the engine ECU.

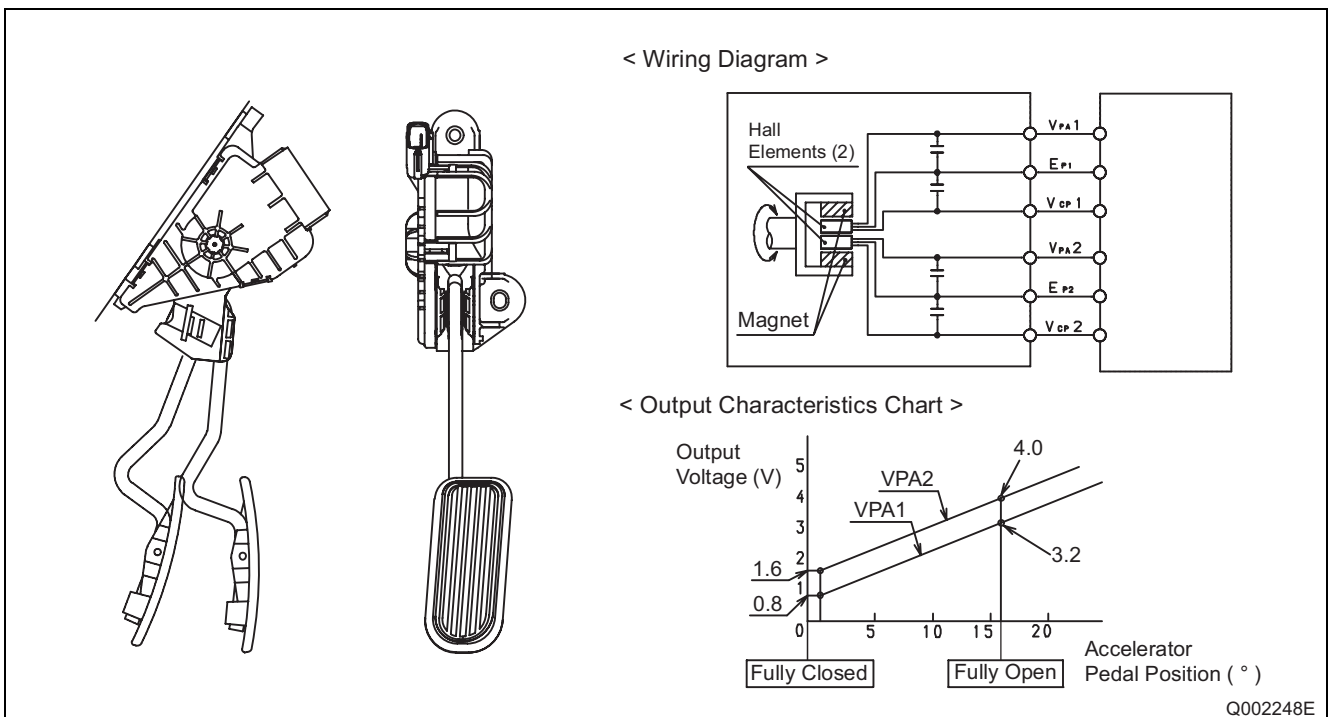

(4) Coolant Temperature Sensor

- The coolant temperature sensor detects the temperature of the engine coolant. The coolant sensor contains a built-in thermistor that undergoes changes in resistance according to coolant temperature. The change in coolant temperature is detected using the change in the thermistor resistance value.

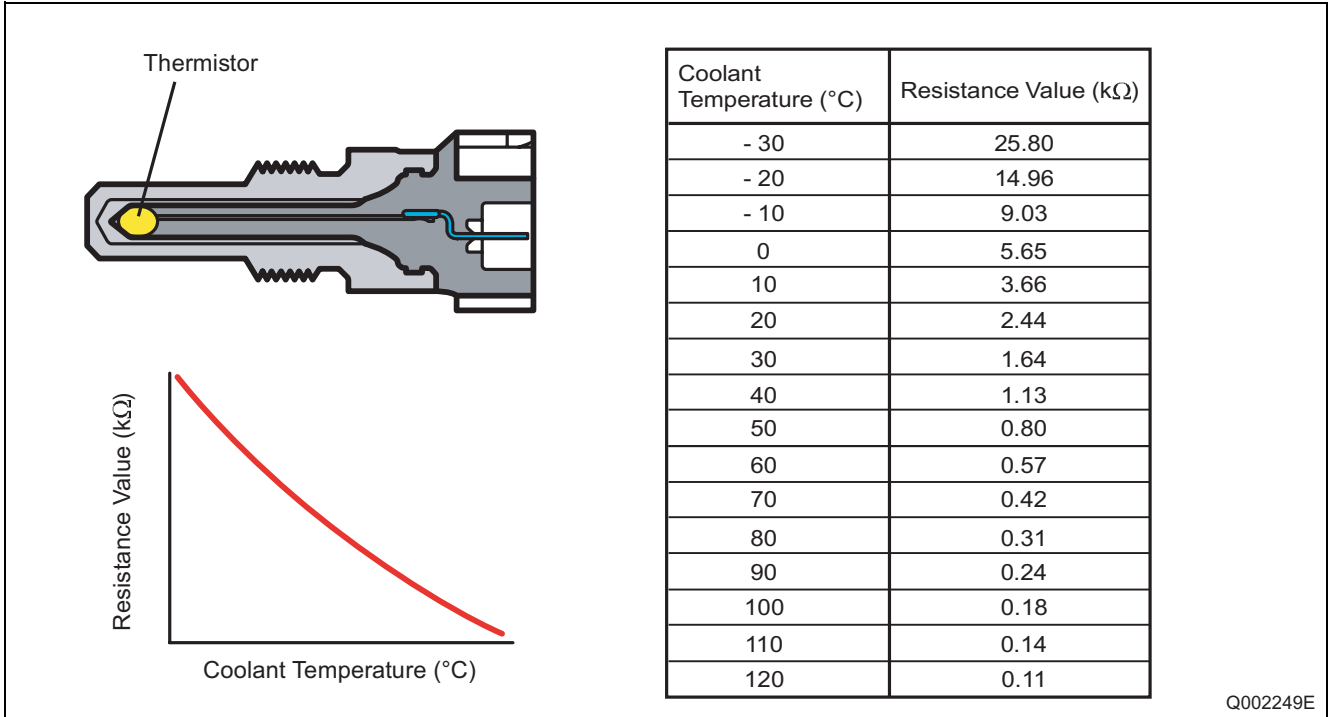

5.5 Exhaust Gas Recirculation (EGR) Valve

- The EGR valve is a linear solenoid type valve. The amount of EGR valve lift is changed according to signals from the engine ECU, which is used to control the volume of exhaust gas sent to the intake manifold.

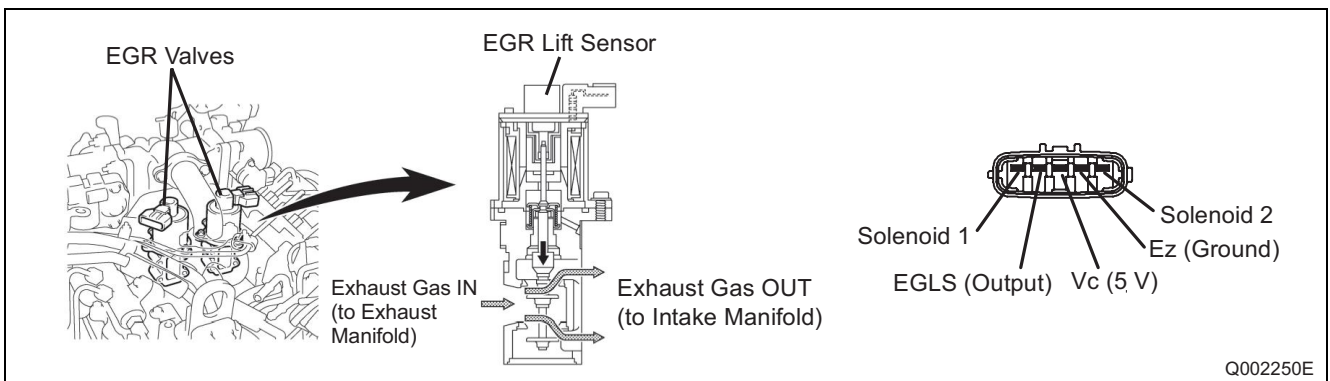

6. FUEL INJECTION CONTROL

6.1 Outline

- Fuel injection control can be roughly divided into the following four types of control: 1) Fuel injection quantity control, 2) fuel injection timing control, 3) fuel injection rate control, 4) fuel injection pressure control. Basic control content is identical to that contained in the general edition manual. However, the fuel injection timing control injection patterns is different for the LAND CRUISER 70. The following is an explanation of the injection pattern.

6.2 Injection Pattern

- Fuel injection timing is controlled according to the duration the injector is energized. First, main injection timing is determined, followed by timing determinations for pilot injections 1 and 2.

Start-Up (After Warm-Up)

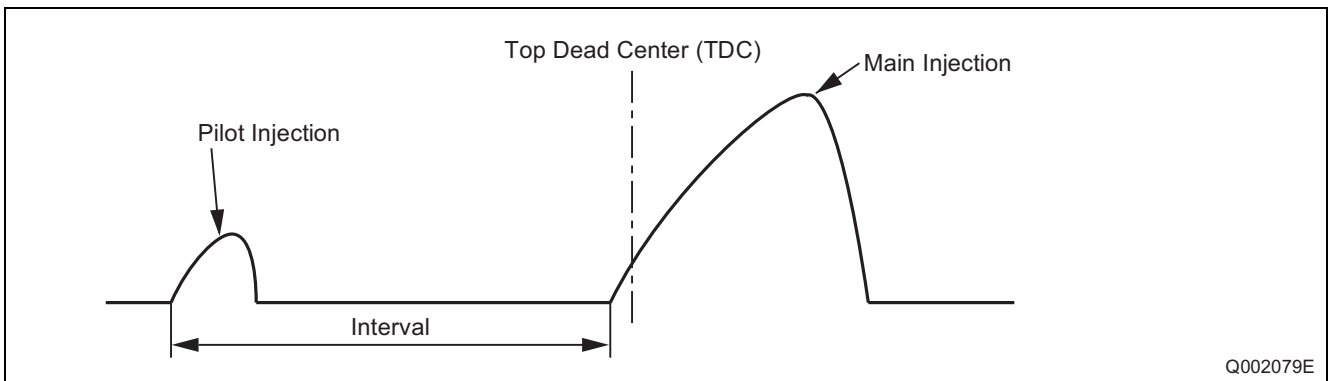

Start-Up (When at Low Temperature), Normal Operation

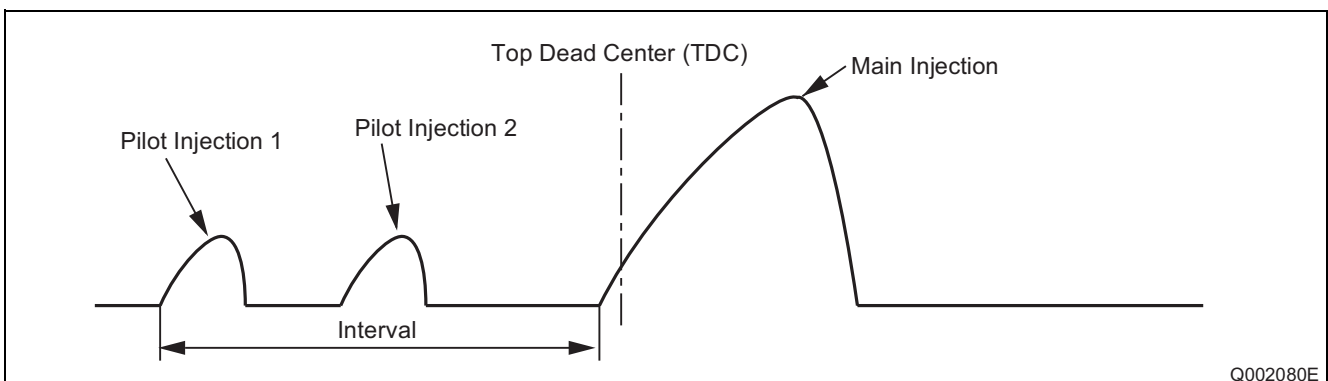

7. ENGINE ECU DIAGNOSTIC TROUBLE CODES (DTC)

7.1 DTC Table

DTC No.	SAE Code	Detection Item	Trouble Area	MIL ON/OFF
P0045	34	Turbocharger / Supercharger Boost Control Solenoid Circuit / Open	-Vacuum Regulating Valve (VRV) -Open or short in VRV circuit Engine ECU	ON
P0069	A5	Boost Pressure Sensor Too High or Too Low	Engine ECU	ON
P0087	49	Fuel / Rail System Pressure Sensor - Too Low	- Open or short in fuel pressure sensor circuit - Rail RH (fuel pressure sensor) - Engine ECU	ON
P0088	78	Fuel / Rail System Pressure Sensor - Too High	- Fuel supply pump (suction control valve) - Rail LH (pressure limiter)	ON
P0093	78	Fuel System Leak Detected -Large Leak	-Fuel line between fuel supply pump and rail - Fuel line between rail and injector - Fuel supply pump -Rail LH (pressure limiter) -Injector (P1238 set simultaneously) - Open or short in EDU circuit (P062D and/or P062E set simultaneously) -Open or short injector circuit (P062D, P062E and/or P1238 set simultaneously) - EDU (P062D and/or P062E set simultaneously) - Fuel line (air bleeding) - Engine ECU	ON
P0100	31	Mass Airflow (MAF) Meter Circuit	- Open or short in MAF meter circuit - MAF meter - Engine ECU	ON
P0101	31	MAF Meter Circuit Range / Performance Problem	- MAF meter	ON
P0102	31	MAF Meter Circuit Low Input	- Open or short in mass airflow (MAF) meter circuit - MAF meter - Engine ECU	ON
P0103	31	MAF Meter Circuit High Input	- Open or short in MAF meter circuit - MAF meter - Engine ECU	ON

DTC No.	SAE Code	Detection Item	Trouble Area	MIL ON/OFF
P0105	35	Manifold Absolute Pressure / Barometric Pressure Circuit	- Open or short in manifold absolute pressure sensor circuit - Manifold absolute pressure sensor - Engine ECU	ON
P0106	31	Manifold Absolute Pressure / Barometric Pressure Circuit Range / Performance Problem	- Manifold absolute pressure sensor	ON
P0107	35	Manifold Absolute Pressure / Barometric Pressure Circuit Low Input	- Open or short in manifold absolute pressure sensor circuit - Manifold absolute pressure sensor - Engine ECU	ON
P0108	35	Manifold Absolute Pressure / Barometric Pressure Circuit High Input	- Open or short in manifold absolute pressure sensor circuit - Manifold absolute pressure sensor - Engine ECU	ON
P0110	24	Intake Air Temperature (IAT) Circuit	- Open or short in IAT sensor circuit - IAT sensor (built into MAF meter) - Engine ECU	ON
P0112	24	IAT Circuit Low Input	- Short in IAT sensor circuit - IAT sensor (built into MAF meter) - Engine ECU	ON
P0113	24	IAT Circuit High Input	- Open in IAT sensor circuit - IAT sensor (built into MAF meter) - Engine ECU	ON
P0115	22	Coolant Temperature Sensor Circuit	- Open or short in coolant temperature sensor circuit - Coolant temperature sensor - Engine ECU	ON
P0116	22	Coolant Temperature Sensor Circuit Range / Performance Problem	- Thermostat - Coolant temperature sensor	ON
P0117	22	Coolant Temperature Sensor Circuit Low Input	- Short in coolant temperature sensor circuit - Coolant temperature sensor - Engine ECU	ON
P0118	22	Coolant Temperature Sensor Circuit High Input	- Open in coolant temperature sensor circuit - Coolant temperature sensor - Engine ECU	ON
P0122	41	Throttle / Accelerator Position Sensor / Switch "A" Circuit Low Input	- Throttle position sensor (for Bank 1) - Open or short in VLU circuit - Open in VC circuit - Engine ECU	ON
P0123	41	Throttle / Accelerator Position Sensor / Switch "A" Circuit High Input	- Throttle position sensor (for Bank 1) - Open in E2 circuit - VC and VLU circuits short circuited - Engine ECU	ON

DTC No.	SAE Code	Detection Item	Trouble Area	MIL ON/OFF
P0168	39	Fuel Temperature Sensor Too High	Fuel temperature sensor	ON
P0180	39	Fuel Temperature Sensor "A" Circuit	<ul style="list-style-type: none"> - Open or short in Fuel temperature sensor circuit - Fuel temperature sensor - Fuel temperature sensor, suction control valve wiring - Engine ECU 	ON
P0182	39	Fuel Temperature Sensor "A" Circuit Low Input	<ul style="list-style-type: none"> - Short in fuel temperature sensor circuit - Fuel temperature sensor - Fuel temperature sensor, suction control valve wiring - Engine ECU 	ON
P0183	39	Fuel Temperature Sensor "A" Circuit High Input	<ul style="list-style-type: none"> - Open in fuel temperature sensor circuit - Fuel temperature sensor - Fuel temperature sensor, suction control valve wiring - Engine ECU 	ON
P0190	49	Rail Pressure Sensor Circuit	<ul style="list-style-type: none"> - Open or short in rail pressure sensor circuit - Rail RH (rail pressure sensor) - Engine ECU 	ON
P0192	49	Rail Pressure Sensor Circuit Low Input	<ul style="list-style-type: none"> - Open or short in rail pressure sensor circuit - Rail RH (rail pressure sensor) - Engine ECU 	ON
P0193	49	Rail Pressure Sensor Circuit High Input	<ul style="list-style-type: none"> - Open or short in rail pressure sensor circuit - Rail RH (fuel pressure sensor) - Engine ECU 	ON
P0222	41	Throttle / Accelerator Position Sensor / Switch "B" Circuit Low Input	<ul style="list-style-type: none"> - Throttle position sensor (for Bank 2) - Open or short in VLU2 circuit - Open in VC circuit - Engine ECU 	ON
P0223	41	Throttle / Accelerator Position Sensor / Switch "B" Circuit High Input	<ul style="list-style-type: none"> - Throttle position sensor (for Bank 2) - Open in E2 circuit - VC and VLU2 circuits short circuited - Engine ECU 	ON
P0234	34	Turbocharger / Supercharger Over-Boost Condition	<ul style="list-style-type: none"> - Vacuum regulating valve - Turbocharger sub-assembly - Vacuum hose - EGR valve assembly - MAF meter - Engine ECU 	ON

DTC No.	SAE Code	Detection Item	Trouble Area	MIL ON/OFF
P0299	34	Turbocharger / Supercharger Under-Boost	<ul style="list-style-type: none"> - Vacuum regulating valve - Turbocharger sub-assembly - Vacuum hose - EGR valve assembly - MAF meter - Engine ECU 	ON
P0335	13, 12	Crankshaft Position Sensor "A" Circuit	<ul style="list-style-type: none"> - Open or short in crankshaft position sensor circuit - Crankshaft position sensor - Crankshaft - Engine ECU 	ON
P0339	13	Crankshaft Position Sensor "A" Circuit Intermittent	<ul style="list-style-type: none"> - Open or short in crankshaft position sensor circuit - Crankshaft position sensor - Crankshaft - Engine ECU 	OFF
P0340	12	Cylinder Recognition Sensor "A" Circuit (Bank 1 or Single Sensor)	<ul style="list-style-type: none"> - Open or short in cylinder recognition sensor circuit - Cylinder recognition sensor - No.2 camshaft timing sprocket - Engine ECU 	ON
P0400	71	Exhaust Gas Recirculation (EGR) Flow	<ul style="list-style-type: none"> - EGR valve stuck - EGR valve does not move smoothly - Open or short in EGR valve circuit - EGR valve deposit - EGR valve passage - Engine ECU 	ON
P0405	96	EGR Sensor "A" Circuit Low	<ul style="list-style-type: none"> - Open or short in No.1 EGR valve position sensor circuit - No.1 EGR valve (EGR valve position sensor) - Engine ECU 	ON
P0406	96	EGR Sensor "A" Circuit High	<ul style="list-style-type: none"> - Open or short in No.1 EGR valve position sensor circuit - No.1 EGR valve (EGR valve position sensor) - Engine ECU 	ON
P0407	96	EGR Sensor "B" Circuit Low	<ul style="list-style-type: none"> - Open or short in No.2 EGR valve position sensor circuit - No.2 EGR valve (EGR valve position sensor) - Engine ECU 	ON
P0408	96	EGR Sensor "B" Circuit High	<ul style="list-style-type: none"> - Open or short in No.2 EGR valve position sensor circuit - No.2 EGR valve (EGR valve position sensor) - Engine ECU 	ON

DTC No.	SAE Code	Detection Item	Trouble Area	MIL ON/OFF
P0488, P213B	15	EGR Throttle Position Control Range / performance	- Throttle valve (for Bank 1) stuck - Throttle valve (for Bank 1) does not move smoothly - Open or short in throttle valve (Bank 1) circuit - Engine ECU	ON
P0500	42	Vehicle Speed Sensor "A"	- Open or short in speedometer circuit - Speedometer assembly - Engine ECU	ON
P0504	51	Brake Switch "A" / "B" Correlation	- Short in stop light switch signal circuit - Stop fuse - IGN fuse - Stop light switch - Engine ECU	OFF
P0560	96	System Voltage	- Open in back up power source circuit - Battery - Battery terminals - EFI fuse - Engine ECU	ON
P0606		Engine ECU	- Engine ECU	ON
P0607	89	Control Module Performance	- Engine ECU	ON
P0617	43	Starter Relay Circuit High	- Starter relay circuit - Ignition switch - Engine ECU	ON
P0627	78	Fuel Pump Control Circuit / Open	- Open or short in suction control valve circuit - Suction Control Valve (SCV) - Fuel temperature sensor, suction control valve wiring - Engine ECU	ON
P062D	97	Fuel Injector Driver Circuit Performance Bank1	- Open or short in No. 1 injector driver (EDU) circuit - Injector - No. 1 EDU - Engine ECU	ON
P062E	97	Fuel Injector Driver Circuit Performance Bank2	- Open or short in No. 2 injector driver (EDU) circuit - Injector - No. 2 EDU - Engine ECU	ON
P1229	78	Fuel Pump System	- Short in fuel supply pump (SCV) circuit - Fuel supply pump (SCV) - Fuel temperature sensor, suction control valve wiring - Engine ECU	ON

DTC No.	SAE Code	Detection Item	Trouble Area	MIL ON/OFF
P1238	78	Injector Malfunction	<ul style="list-style-type: none"> - Injector - Injector driver (EDU) (P062D and/or P062E set simultaneously) - Open or short in engine wiring harness (P062D and/or P062E set simultaneously) - Connector connection (P062D and/or P062E set simultaneously) - Compression pressure 	ON
P1248		EGR Flow Bank 2	<ul style="list-style-type: none"> - EGR valve stuck - EGR valve does not move smoothly - Open or short in EGR valve circuit - EGR valve deposit - EGR valve passage - Engine ECU 	ON
P1251	34	Turbocharger / Supercharger Over-Boost Condition (Too High)	<ul style="list-style-type: none"> - Vacuum regulating valve - Turbocharger sub-assembly - Vacuum hose - EGR valve assembly - MAF meter - Engine ECU 	ON
P1495	23	IAT Sensor 1 Circuit	<ul style="list-style-type: none"> - Open or short in IAT sensor circuit - IAT sensor - Engine ECU 	ON
P1496	23	IAT Sensor 1 Circuit Low	<ul style="list-style-type: none"> - Short in IAT sensor circuit - IAT sensor - Engine ECU 	ON
P1497	23	IAT Sensor 1 Circuit High	<ul style="list-style-type: none"> - Open in IAT sensor circuit IAT sensor - Engine ECU 	ON
P1601	89	Injector Correction Circuit Malfunction (EEPROM)	<ul style="list-style-type: none"> - Injector compensation code - Engine ECU 	ON
P1611	17	IC Circuit Malfunction	<ul style="list-style-type: none"> - Engine ECU 	ON
P2120	19	Throttle / Accelerator Position Sensor / Switch "D" Circuit	<ul style="list-style-type: none"> - Accelerator position sensor - Accelerator pedal - Accelerator pedal rod (arm) deformed - Engine ECU 	ON
P2121	19	Throttle / Accelerator Position Sensor / Switch "D" Circuit Range / Performance	<ul style="list-style-type: none"> - Accelerator position sensor circuit - Accelerator pedal position sensor - Engine ECU 	ON
P2122	19	Throttle / Accelerator Position Sensor / Switch "D" Circuit Low Input	<ul style="list-style-type: none"> - Accelerator position sensor - Open in VCP1 and VCP2 circuit - VPA circuit open or ground short - Accelerator pedal - Accelerator pedal rod (arm) deformed - Engine ECU 	ON

DTC No.	SAE Code	Detection Item	Trouble Area	MIL ON/OFF
P2123	19	Throttle / Accelerator Position Sensor / Switch "D" Circuit High Input	- Accelerator position sensor - Open in EP1 and EP2 circuit - Accelerator pedal - Accelerator pedal rod (arm) deformed - Engine ECU	ON
P2125	19	Throttle / Accelerator Position Sensor / Switch "E" Circuit	- Accelerator position sensor - Accelerator pedal - Accelerator pedal rod (arm) deformed - Engine ECU	ON
P2127	19	Throttle / Accelerator Position Sensor / Switch "E" Circuit Low Input	- Accelerator position sensor - Open in VCP2 circuit - VPA2 circuit open or ground short - Accelerator pedal - Accelerator pedal rod (arm) deformed - Engine ECU	ON
P2128	19	Throttle / Accelerator Position Sensor / Switch "E" Circuit High Input	- Accelerator position sensor - Open in EP2 circuit - Accelerator pedal - Accelerator pedal rod (arm) deformed - Engine ECU	ON
P2138	19	Throttle / Accelerator Position Sensor / Switch "D" / "E" Voltage Correlation	- Accelerator position sensor - Short in VPA1 and VPA2 circuit - Accelerator pedal - Accelerator pedal rod (arm) deformed - Engine ECU	ON
P2226	A5	Barometric Pressure Circuit	- Engine ECU	ON
P2228	A5	Barometric Pressure Circuit Low Input	- Engine ECU	ON
P2229	A5	Barometric Pressure Circuit High Input	- Engine ECU	ON

7.2 Fail-Safe Table

DTC No.	Detection Item	Fail-Safe Operation	Fail-Safe Deactivation Conditions
P0087	Fuel Rail / System Pressure - Too Low	Limits engine power	Ignition switch OFF
P0088	Fuel Rail / System Pressure - Too High	Limits engine power	Ignition switch OFF
P0093	Fuel System Leak Detected - Large Leak	Limit engine power for 1 minute and then stall the engine	Ignition switch OFF
P0100	Mass or Volume Airflow Circuit	EGR valve fixed at specified opening angle	Sensor output detected normal
P0102	Mass or Volume Airflow Circuit Low Input	EGR valve fixed at specified opening angle	Sensor output detected normal
P0103	Mass or Volume Airflow Circuit High Input	EGR valve fixed at specified opening angle	Sensor output detected normal
P0105	Manifold Absolute Pressure / Barometric Pressure Circuit	Boost pressure fixed at specified value	Sensor output detected normal

DTC No.	Detection Item	Fail-Safe Operation	Fail-Safe Deactivation Conditions
P0107	Manifold Absolute Pressure / Barometric Pressure Circuit Low Input	Boost pressure fixed at specified value	Sensor output detected normal
P0108	Manifold Absolute Pressure / Barometric Pressure Circuit High Input	Boost pressure fixed at specified value	Sensor output detected normal
P0110	Intake Air Temperature Circuit	Intake air temperature value fixed	Sensor output detected normal
P0112	Intake Air Temperature Circuit Low Input	Intake air temperature value fixed	Sensor output detected normal
P0113	Intake Air Temperature Circuit High Input	Intake air temperature value fixed	Sensor output detected normal
P0115	Coolant Temperature Circuit	Coolant temperature sensor output fixed at specified value (fixed value varies depending on conditions)	Sensor output detected normal
P0117	Coolant Temperature Circuit Low Input	Coolant temperature sensor output fixed at specified value (fixed value varies depending on conditions)	Sensor output detected normal
P0118	Coolant Temperature Circuit High Input	Coolant temperature sensor output fixed at specified value (fixed value varies depending on conditions)	Sensor output detected normal
P0122	Throttle / Accelerator Position Sensor / Switch "A" Circuit Low Input	Limits engine power	Ignition switch OFF
P0123	Throttle / Accelerator Position Sensor / Switch "A" Circuit High Input	Limits engine power	Ignition switch OFF
P0168	Rail Temperature Too High	Limits engine power	Sensor output detected normal
P0180	Rail Temperature Sensor "A" Circuit	Rail temperature fixed at specified value	Sensor output detected normal
P0182	Rail Temperature Sensor "A" Circuit low Input	Rail temperature fixed at specified value	Sensor output detected normal
P0183	Rail Temperature Sensor "A" Circuit High Input [Fuel temperature sensor high input]	Rail temperature fixed at specified value	Sensor output detected normal
P0190	Rail Pressure Sensor Circuit	Limits engine power	Ignition switch OFF
P0192	Rail Pressure Sensor Circuit Low Input	Limits engine power	Ignition switch OFF
P0193	Rail Pressure Sensor Circuit High Input	Limits engine power	Ignition switch OFF
P0222	Throttle / Accelerator Position Sensor / Switch "B" Circuit Low Input	Limits engine power	Ignition switch OFF
P0223	Throttle / Accelerator Position Sensor / Switch "B" Circuit High Input	Limits engine power	Ignition switch OFF
P0234	Turbocharger / Supercharger Over-Boost Condition	Limits engine power	Ignition switch OFF
P0299	Turbocharger / Supercharger Under-Boost	Limits engine power	Ignition switch OFF

DTC No.	Detection Item	Fail-Safe Operation	Fail-Safe Deactivation Conditions
P0335	Crankshaft Position Sensor "A" Circuit	Engine stopped	Sensor output detected normal
P0340	Cylinder Recognition Sensor "A" Circuit (Bank 1 or Single Sensor)	Limits engine power	Sensor output detected normal
P0400	Exhaust Gas Recirculation Flow	Limits engine power	Ignition switch OFF
P0405	Exhaust Gas Recirculation Sensor "A" Circuit Low	EGR valve fixed at specified opening angle	Ignition switch OFF
P0406	Exhaust Gas Recirculation Sensor "A" Circuit High	EGR valve fixed at specified opening angle	Ignition switch OFF
P0407	Exhaust Gas Recirculation Sensor "B" Circuit Low	EGR valve fixed at specified opening angle	Ignition switch OFF
P0408	Exhaust Gas Recirculation Sensor "B" Circuit High	EGR valve fixed at specified opening angle	Ignition switch OFF
P0488	Exhaust Gas Recirculation Throttle Position Control Range/Performance	Limits engine power	Ignition switch OFF
P0500	Vehicle Speed Sensor "A"	Vehicle speed fixed at 0 km/h (0 mph)	Sensor output detected normal
P0627	Fuel Pump Control Circuit / Open	Engine stopped	Sensor output detected normal
P062D	Fuel Injector Driver Circuit Performance Bank 1	When one injector circuit is malfunctioning, engine power is limited. When two or more injector circuits are malfunctioning, the engine is stopped.	Ignition switch OFF
P062E	Fuel Injector Driver Circuit Performance Bank 2	When one injector circuit is malfunctioning, engine power is limited. When two or more injector circuits are malfunctioning, the engine is stopped.	Ignition switch OFF
P1229	Fuel Pump System	Limits engine power	Ignition switch OFF
P1248	Exhaust Gas Recirculation Flow Bank 2	Limits engine power	Ignition switch OFF
P1251	Turbocharger / Supercharger Over-Boost Condition (Too High)	Limits engine power	Ignition switch OFF
P1495	Intake Air Temperature Sensor 1 Circuit	Intake air temperature fixed at specified value	Sensor output detected normal
P1496	Intake Air Temperature Sensor 1 Circuit Low	Intake air temperature fixed at specified value	Sensor output detected normal
P1497	Intake Air Temperature Sensor 1 Circuit High	Intake air temperature fixed at specified value	Sensor output detected normal
P1611	Engine ECU Inside IC	Engine stopped	Ignition switch OFF
P2120	Throttle / Accelerator Position Sensor/ Switch "D" Circuit	Limits engine power	Ignition switch OFF
P2121	Throttle / Accelerator Position Sensor/ Switch "D" Circuit Range/Performance	Limits engine power	Ignition switch OFF

DTC No.	Detection Item	Fail-Safe Operation	Fail-Safe Deactivation Conditions
P2122	Throttle / Accelerator Position Sensor/ Switch "D" Circuit Low Input	Limits engine power	Ignition switch OFF
P2123	Throttle / Accelerator Position Sensor/ Switch "D" Circuit High Input	Limits engine power	Ignition switch OFF
P2125	Throttle / Accelerator Position Sensor/ Switch "E" Circuit	Limits engine power	Ignition switch OFF
P2127	Throttle / Accelerator Position Sensor/ Switch "E" Circuit Low Input	Limits engine power	Ignition switch OFF
P2128	Throttle / Accelerator Position Sensor/ Switch "E" Circuit High Input	Limits engine power	Ignition switch OFF
P2138	Throttle / Accelerator Position Sensor/ Switch "D"/ "E" Voltage Correlation	Limits engine power	Ignition switch OFF
P213B	Exhaust Gas Recirculation Throttle Position Control (Range / Performance)	Limits engine power	Ignition switch OFF
P2226	Barometric Pressure Circuit	Atmospheric pressure fixed at specified valve	Sensor output detected normal
P2228	Barometric Pressure Circuit Low Input	Atmospheric pressure fixed at specified valve	Sensor output detected normal
P2229	Barometric Pressure Circuit High Input	Atmospheric pressure fixed at specified valve	Sensor output detected normal

8. ATTACHED MATERIALS

8.1 Engine ECU External Wiring Diagram

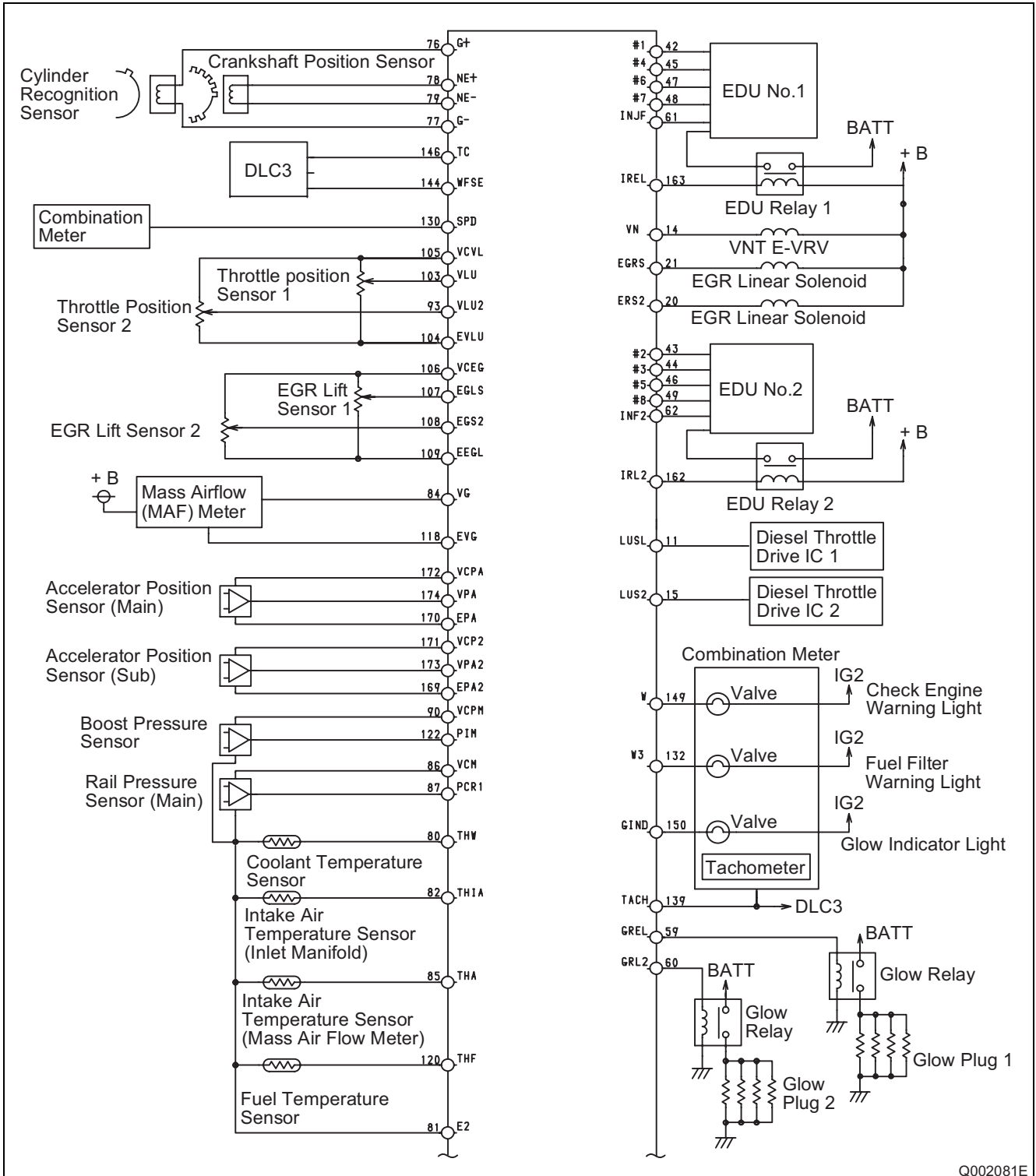

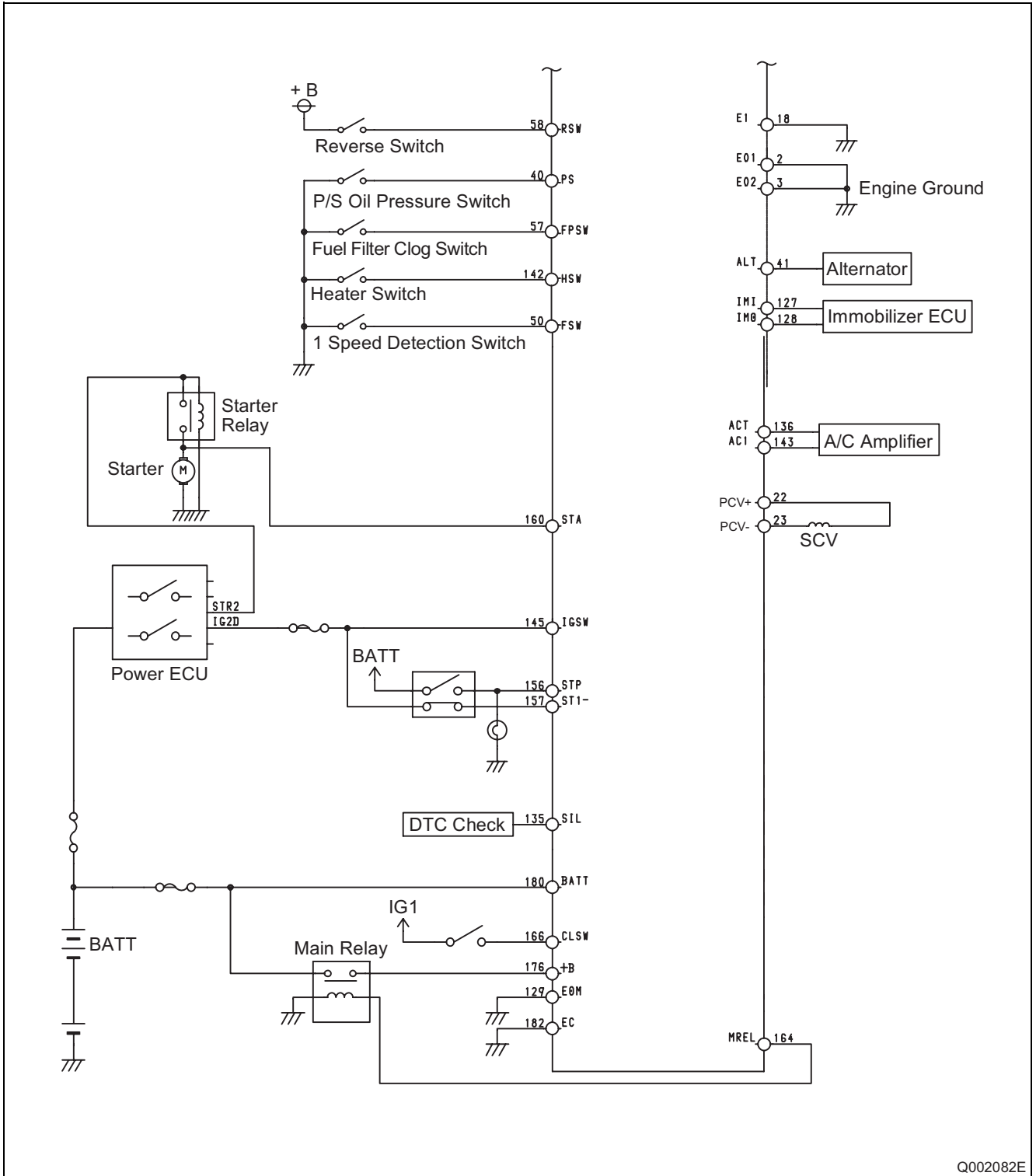

8.2 Connector Terminal Layout

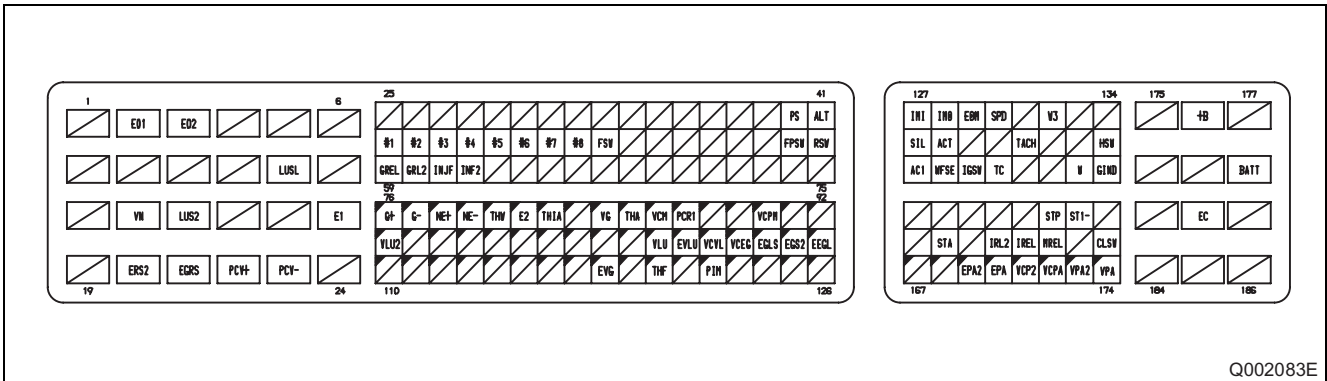

Q002083E

No.	Code	Terminal Description	No.	Code	Terminal Description
1	-	-	14	E-VRV	-
2	E01	Engine Ground	15	LUS2	Electronic Control Throttle Drive IC
3	E02	Engine Ground	16	-	-
4	-	-	17	-	-
5	-	-	18	E1	Engine Ground
6	-	-	19	-	-
7	-	-	20	-	-
8	-	-	21	ERS2	EGR Linear Solenoid
9	-	-	22	EGRS	EGR Linear Solenoid
10	-	-	23	PCV+	SCV
11	LUSL	Electronic Control Throttle Drive IC	24	PCV-	SCV
12	-	-	25	-	-
13	-	-	26	-	-
27	-	-	66	-	-
28	-	-	67	-	-
29	-	-	68	-	-
30	-	-	69	-	-
31	-	-	70	-	-
32	-	-	71	-	-
33	-	-	72	-	-
34	-	-	73	-	-
35	-	-	74	-	-
36	-	-	75	-	-
37	-	-	76	G+	Cylinder Recognition Sensor +
38	-	-	77	G-	Cylinder Recognition Sensor -
39	-	-	78	NE+	Crankshaft Position Sensor +
40	PS	Power Steering Pressure Switch	79	NE-	Crankshaft Position Sensor -
41	ALT	Alternator	80	THW	Coolant Temperature Sensor
42	#1	EDU	81	E2	Sensor Ground

No.	Code	Terminal Description	No.	Code	Terminal Description
43	#2	EDU	82	THIA	IAT Sensor (with built-in Intake Manifold)
44	#3	EDU	83	-	-
45	#4	EDU	84	VG	MAF Meter 1
46	#5	EDU	85	THA	IAT Sensor (with built-in MAF meter)
47	#6	EDU	86	VCM	Rail Pressure Sensor Power Supply
48	#7	EDU	87	PCR1	Rail Pressure Sensor
49	#8	EDU	88	-	-
50	FSW	1 Speed Detection Switch	89	-	-
51	-	-	90	VCPM	Boost Pressure Sensor Power Supply
52	-	-	91	-	-
53	-	-	92	-	-
54	-	-	93	VLU2	Throttle Position Sensor
55	-	-	94	-	-
56	-	-	95	-	-
57	FPSW	Fuel Filter Clog Switch	96	-	-
58	RSW	Reverse Switch	97	-	-
59	GREL	Glow Relay	98	-	-
60	GRL2	Glow Relay	99	-	-
61	INJF	EDU	100	-	-
62	INF2	EDU	101	-	-
63	-	-	102	-	-
64	-	-	103	VLU	Throttle Position Sensor
65	-	-	104	EVLU	Throttle Position Sensor Ground
105	VCVL	Throttle Position Sensor Power Supply	143	AC 1	A/C Amplifier
106	VCEG	EGR Lift Sensor Power Supply	144	WFSE	DLC3
107	EGLS	EGR Lift Sensor 1	145	IGSW	Ignition Switch
108	EGS2	EGR Lift Sensor 2	146	TC	Test Terminal
109	EEGL	EGR Lift Sensor Ground	147	-	-
110	-	-	148	-	-
111	-	-	149	W	Check Engine Warning Light
112	-	-	150	GIND	Glow Indicator Light
113	-	-	151	-	-
114	-	-	152	-	-
115	-	-	153	-	-
116	-	-	154	-	-
117	-	-	155	-	-
118	EVG	MAF Meter (Ground)	156	STP	Stop Light Switch
119	-	-	157	ST1-	Stop Light Switch
120	THF	Rail Pressure Sensor	158	-	-
121	-	-	159	-	-

No.	Code	Terminal Description	No.	Code	Terminal Description
122	PIM	Boost pressure Sensor	160	STA	Starter Relay
123	-	-	161	-	-
124	-	-	162	IRL2	Injector Relay 2
125	-	-	163	IREL	Injector Relay 1
126	-	-	164	MREL	Main Relay
127	IMI	Immobilizer ECU	165	-	-
128	IMO	Immobilizer ECU	166	CLSW	Clutch Switch
129	EOM	Immobilizer 判定	167	-	-
130	SPD	Vehicle Speed Sensor (Combination Meter)	168	-	-
131	-	-	169	EPA2	Accelerator Position Sensor (Main) Ground
132	W3	Fuel Filter Warning Light	170	EPA	Accelerator Position Sensor (Main) Ground
133	-	-	171	VCP2	Accelerator Position Sensor (Sub) Power Supply
134	-	-	172	VCPA	Accelerator Position Sensor (Main) Power Supply
135	SIL	Diagnosis Communication	173	VPA2	Accelerator Position Sensor Sub
136	ACT	A/C Amplifier	174	VPA	Accelerator Position Sensor Main
137	-	-	175	-	-
138	-	-	176	+B	Battery + Main Relay 1
139	TACH	Tachometer	177	-	-
140	-	-	178	-	-
141	-	-	179	-	-
142	HSW	Heater Switch	180	BATT	Battery
181	-	-	184	-	-
182	EC	Case Ground	185	-	-
183	-	-	186	-	-

Published : March, 2007

Edited and published by:

DENSO CORPORATION

Service Department

1-1 Showa-cho, Kariya, Aichi Prefecture, Japan