

FRAME AND BUMPERS

CONTENTS

	page		page
BUMPERS	5	FRAME	1
BUMPERS	16	FRAME	10

FRAME

INDEX

	page		page
Frame Dimensions	1	Fuel Tank Support Strap	4
Front Skid Plate	1	General Information	1
Fuel Filler Hose Splash Shield—XJ Vehicles	4	Transfer Case Skid Plate	3
Fuel Tank Skid Plate	3		

GENERAL INFORMATION

Jeep XJ Vehicles (Fig. 1) and the cab section of Jeep are constructed as a unitized body and frame.

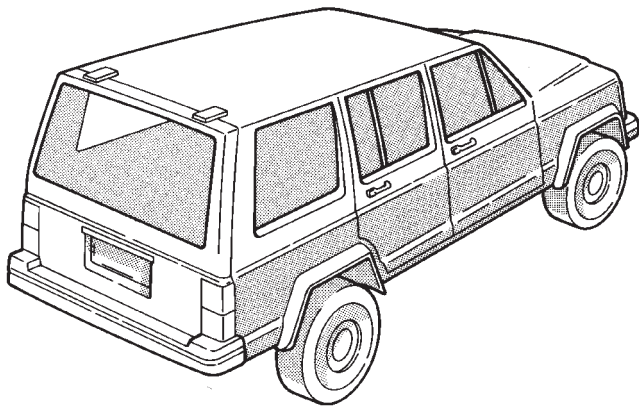

J911N-12

Fig. 1 Jeep—XJ

Jeep XJ unibodies are constructed from special high-strength steel and coated metals. These types of metals reduce weight and provide strength.

A vehicle constructed as a unibody reacts differently to the impact of a collision. While the damage at the immediate point of impact is easily recognizable, the damage must be diagnosed to expose it.

With unibody construction, there are five logical areas to examine to expose damage:

- Damage at the immediate point of impact—primary damage.

- The other (lessor) body damage—secondary damage.
- Damage to the exterior trim and other surface-attached components.
- Damage to the mechanical components.
- The interior trim and accessory damage.

When there is damage to a vehicle, the alignment points must be returned to specifications.

FRAME DIMENSIONS

Frame dimensions are listed in millimeter scale. All dimensions are from center to center of Principal Locating Point (PLP), or from center to center of PLP and fastener location (Fig. 2).

FRONT SKID PLATE

REMOVAL

- (1) Remove the screws that attach skid plate to side sills (Fig. 3).
- (2) Remove the nuts that attach the skid plate to the crossmember (Fig. 3).
- (3) Remove the skid plate from the vehicle (Fig. 3).

INSTALLATION

- (1) Position the skid plate at front crossmember and side sills (Fig. 3).
- (2) Install the nuts to attach the skid plate to crossmember.
- (3) Install the screws to attach skid plate to side sills.

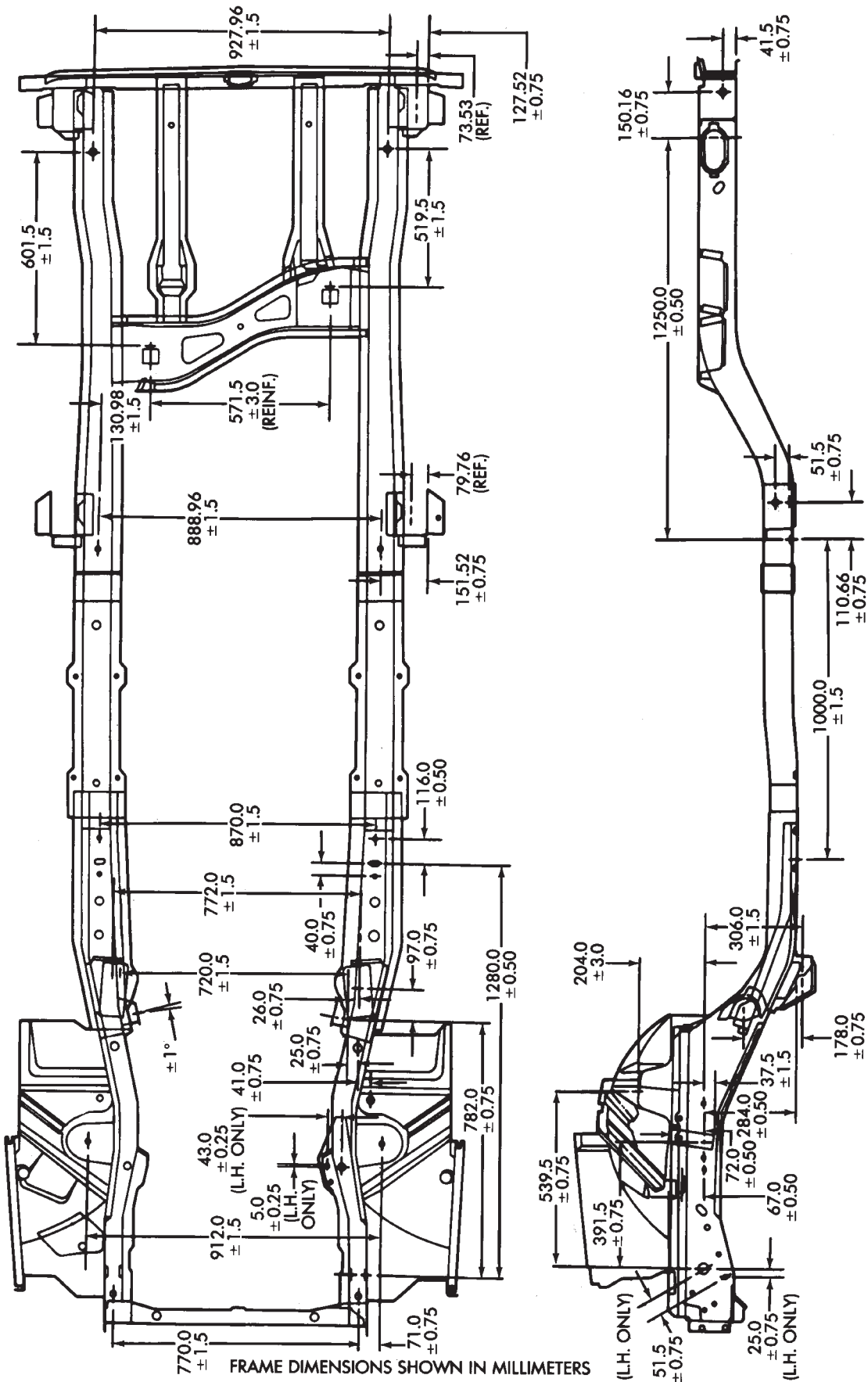

Fig. 2 Frame Alignment Reference Dimensions—XJ Vehicles

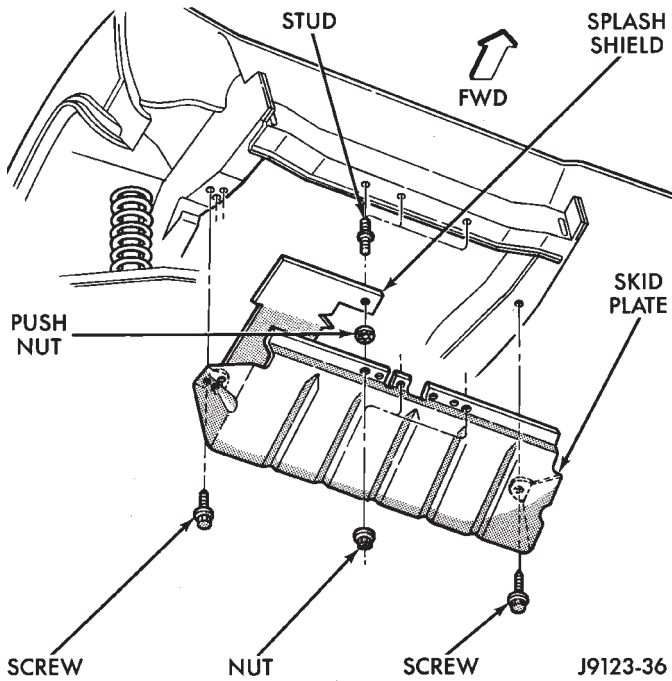

Fig. 3 Front Skid Plate Removal/Installation

TRANSFER CASE SKID PLATE

REMOVAL

- (1) Support the skid plate.
- (2) Remove the bolts that attach the skid plate to the transmission support crossmember and frame sill (Fig. 4).

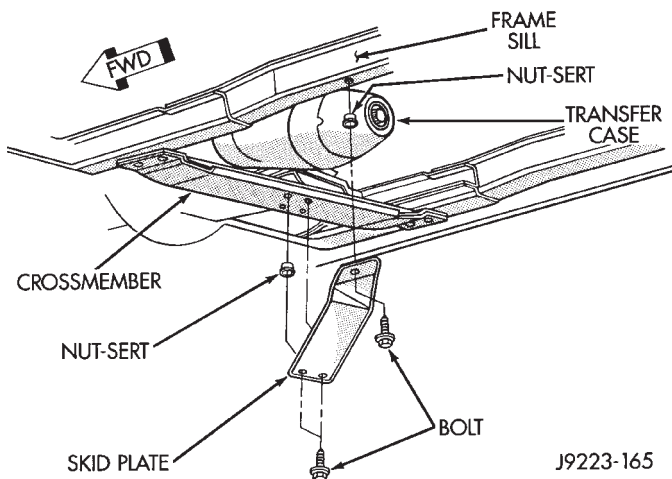

Fig. 4 Transfer Case Skid Plate

- (3) Remove the support and skid plate from the vehicle.

INSTALLATION

- (1) Position and support the skid plate at the frame sill and transmission support crossmember (Fig. 4).

- (2) Attach the skid plate to the frame sill and crossmember with bolts. Tighten bolts to 22 N·m (16 ft. lbs.) torque.

FUEL TANK SKID PLATE

REMOVAL

- (1) Position a support under skid plate.
- (2) Remove the bolts that attach skid plate to underbody side rails (Fig. 5 and 6).

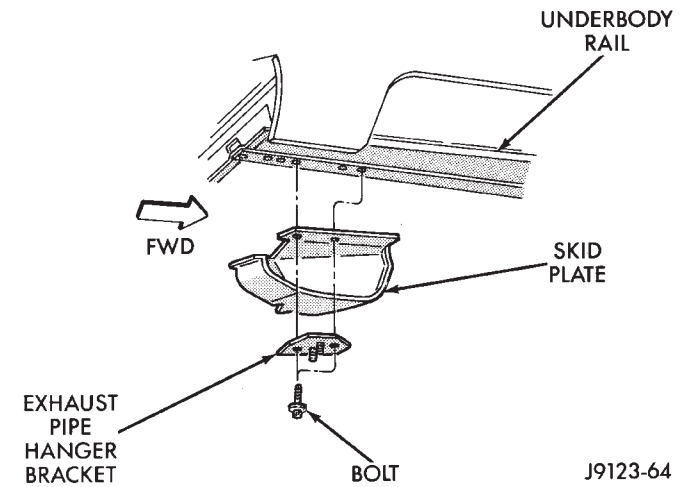

Fig. 5 Fuel Tank Skid Plate W/O Trailer Hitch Or Tow Hook

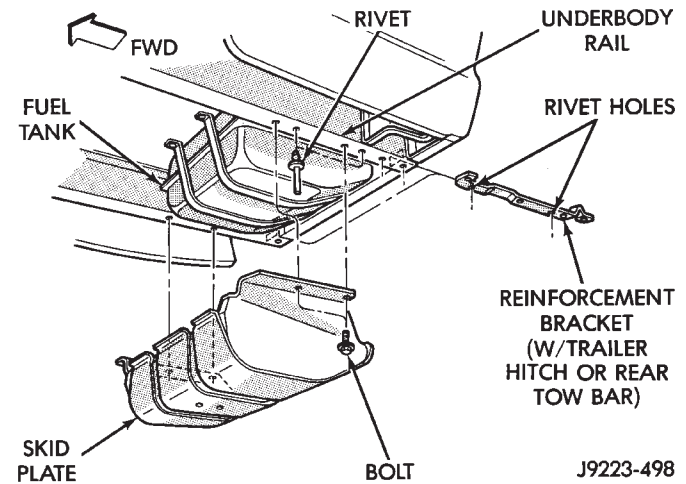

Fig. 6 Fuel Tank Skid Plate With Trailer Hitch Or Tow Hook

- (3) Remove the support and the skid plate from the vehicle.

INSTALLATION

- (1) Position and support skid plate under fuel tank.
- (2) Install bolts to attach the skid plate to underbody rails. Tighten the bolts to 50 N·m (37 ft. lbs.) torque.
- (3) Remove the support from under skid plate.

FUEL FILLER HOSE SPLASH SHIELD—XJ VEHICLES

REMOVAL

(1) Remove the screws that attach fuel filler hose splash shield to wheelhouse panel and frame rail (Fig. 7).

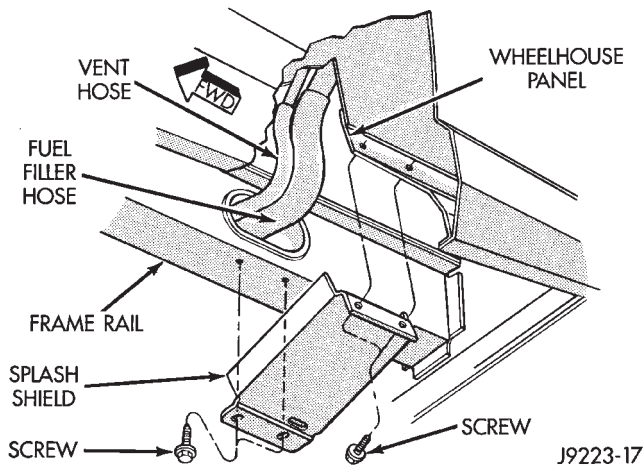

Fig. 7 Fuel Filler Hose Splash Shield—XJ Vehicles

(2) Remove the hose splash shield from wheelhouse panel and frame rail (Fig. 7).

INSTALLATION

(1) Position fuel filler hose splash shield at wheelhouse panel and frame rail.

(2) Install screws to attach splash shield to wheelhouse panel and frame rail.

FUEL TANK SUPPORT STRAP

SERVICE INFORMATION

XJ fuel tank support straps are attached to the underside of the vehicle via T-slots and hole-slots in the frame members.

REMOVAL

(1) If equipped, position a support under skid plate.

(2) If equipped, remove the bolts that attach skid plate to underbody side rails.

(3) If applicable, remove the support and skid plate from fuel tank.

(4) Support fuel tank.

(5) Loosen nut from fuel tank support strap bolt to allow bolt head to be removed from hole-slot in frame member (Fig. 8).

(6) Remove the strap T-end from frame member T-slot (Fig. 9).

(7) Separate support strap from fuel tank and remove it from vehicle.

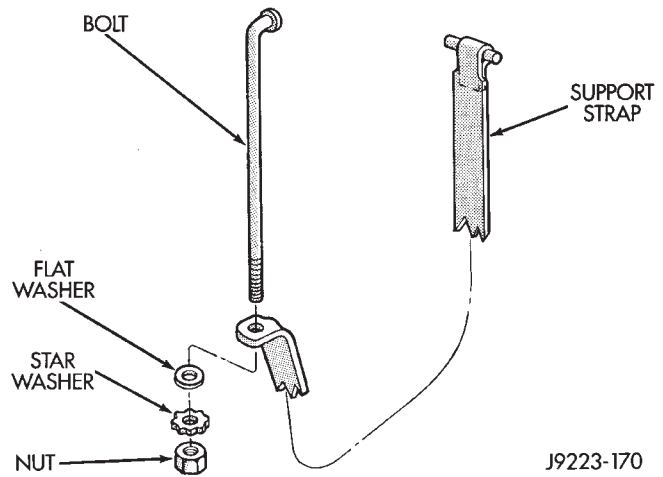

Fig. 8 Fuel Tank Support Strap—XJ Vehicles

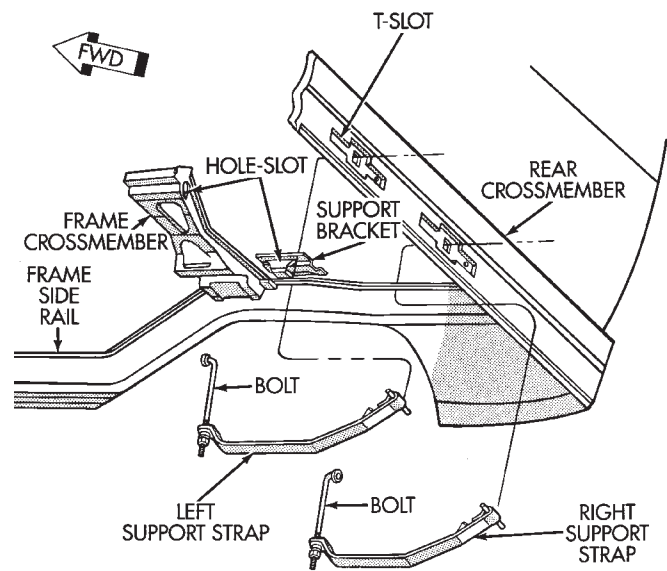

Fig. 9 Fuel Tank Support Straps—XJ Vehicles

INSTALLATION

(1) Position support strap around fuel tank.

(2) Insert strap T-end in frame member T-slot.

(3) Insert bolt in hole-slot in frame member. Tighten nut on the bolt until bolt-head and T-end are seat and strap is tight against the bottom of fuel tank.

(4) Remove the support from the fuel tank.

(5) If removed, position and support and the fuel tank skid plate under the fuel tank.

(6) If applicable, install the bolts that attach the skid plate to the underbody side rails. Tighten the bolts to 50 N·m (37 ft. lbs.) torque.

(7) Remove the support from under the skid plate.

BUMPERS

INDEX

	page		page
Front Bumper	5	Rear Bumper	8
Front Tow Hooks	7	Rear Tow Hook	9

FRONT BUMPER

REMOVAL/DISASSEMBLY

(1) The bumper guards, end caps and tow hooks can be removed from XJ front bumpers with the bumper attached to the vehicle. Do not remove the bumper from the vehicle if only these components require service.

If equipped with a brush guard, refer to the Brush Guard Removal within Group 23, Body Components.

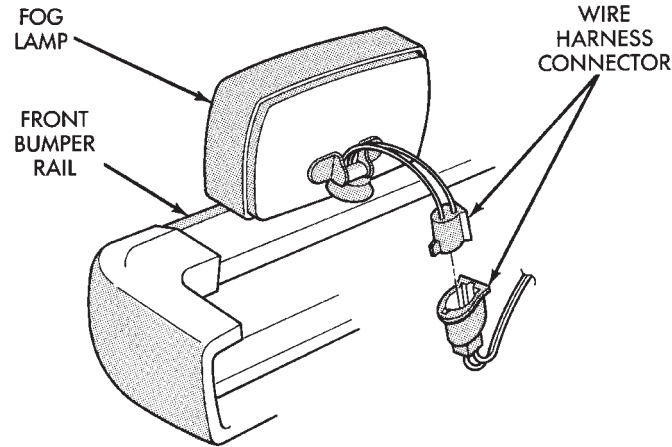

Fig. 1 Fog Lamp Wire Harness Connector

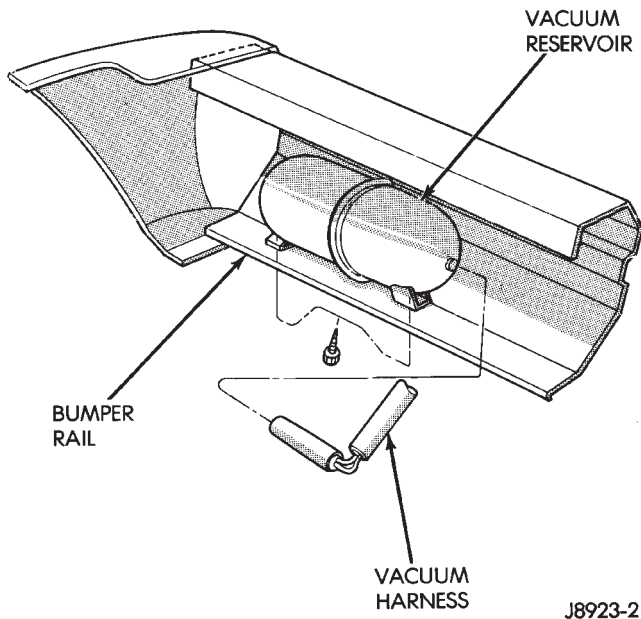

Fig. 2 Vacuum Reservoir—Left Side

(2) Disconnect the fog lamp wire harness connectors, if equipped (Fig. 1).

(3) Disconnect the vacuum reservoir tube harness connectors (Fig. 2 and 3).

(4) Remove the locknuts and Torx-head bolts that attach the tow hook straps (Fig. 4) to the underbody sillmember.

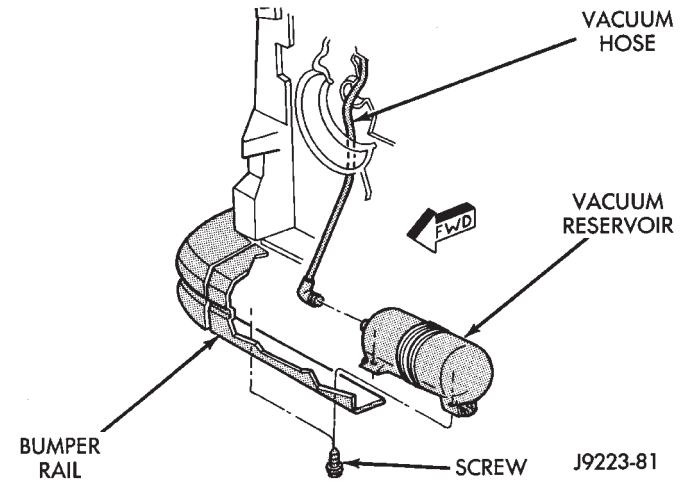

Fig. 3 Vacuum Reservoir—Right Side With Speed Control Only

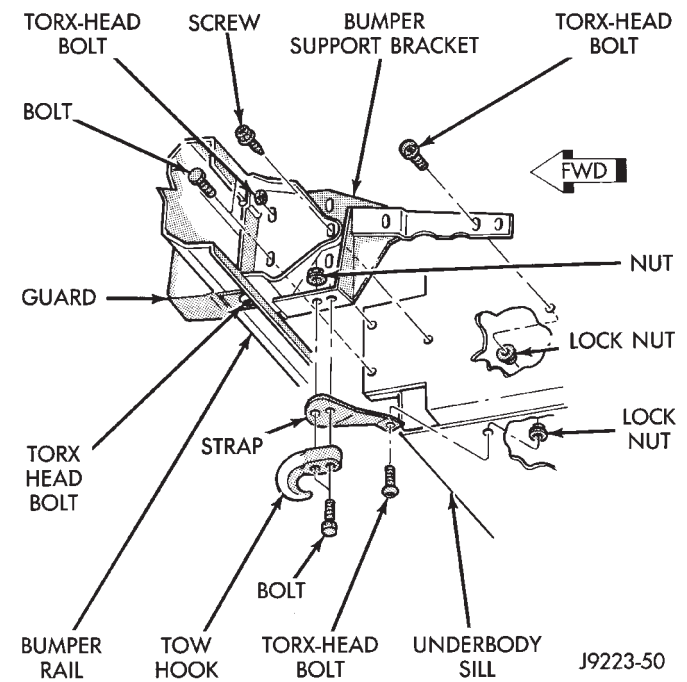

Fig. 4 Tow Hook & Strap—XJ Vehicles

The retaining screws and the steering gear skid plate must be removed before the left strap can be removed from the sillmember.

- (5) Detach the tow hook straps from the sillmember.
- (6) Support the bumper.
- (7) Remove the bolts that attach the bumper support brackets to the right and left sillmembers (Fig. 5).

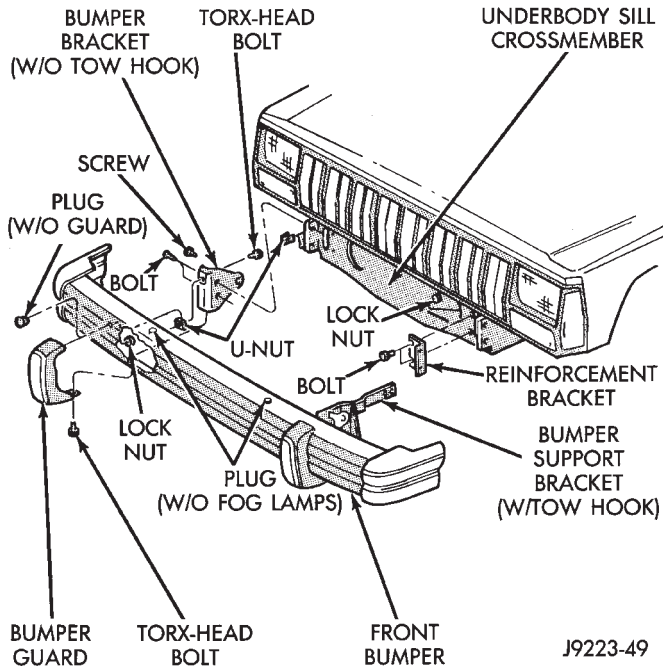

Fig. 5 Front Bumper Removal/Installation

- (8) Remove the support and the bumper from the vehicle (Fig. 5).
- (9) Remove the nuts and bolts that attach the tow hooks to the bumper support brackets.
- (10) Remove the support brackets (Fig. 6), bumper guards (Fig. 7) and caps (Fig. 8) from the bumper rail.

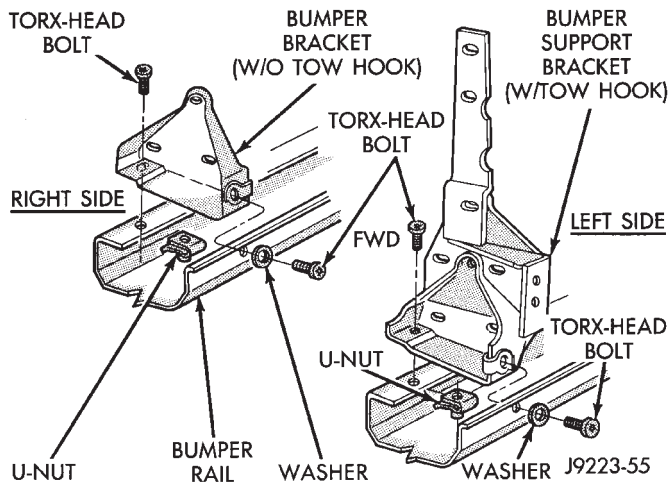

Fig. 6 Bumper Support Bracket Removal/Installation

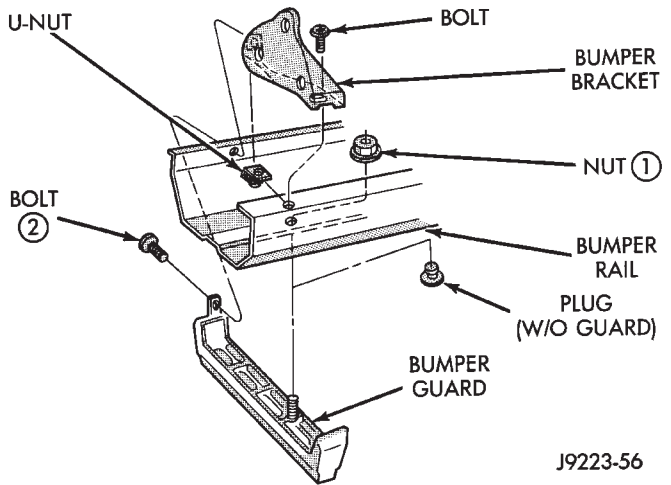

Fig. 7 Bumper Guard Removal/Installation

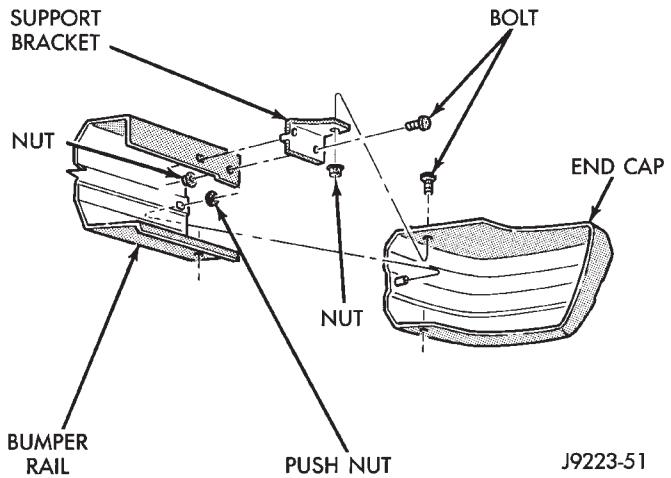

Fig. 8 Bumper End Cap Removal/Installation

- (11) Remove the license plate bracket (Fig. 9), if equipped, from the bumper rail.

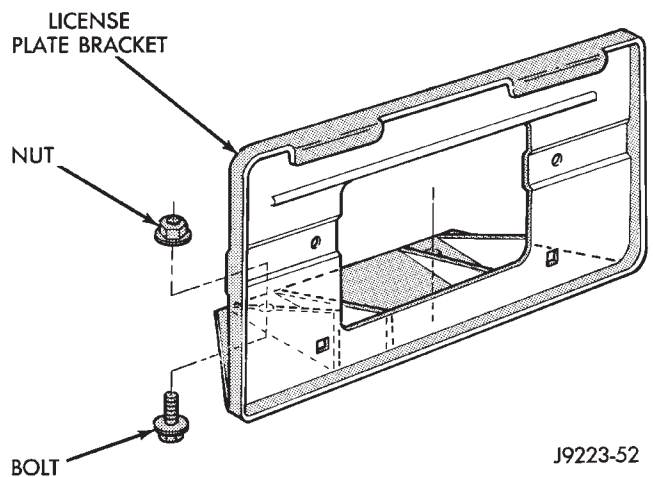
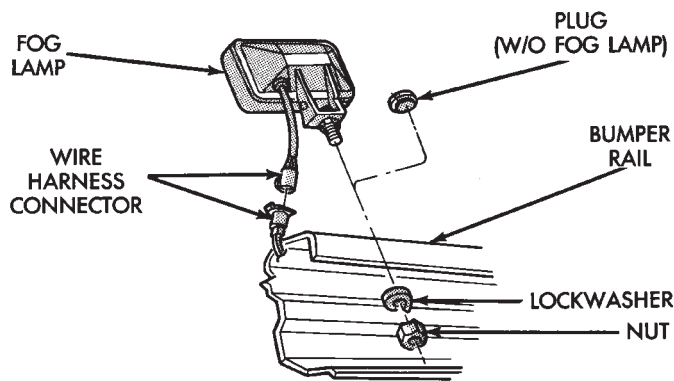

Fig. 9 Bumper License Plate Bracket Removal/Installation

(12) Remove the fog lamps (Fig. 10) from the bumper rail.



J9123-421

Fig. 10 Fog Lamp

(13) If necessary, remove the vacuum reservoir(s) from the bumper rail.

(14) If necessary, remove the sill crossmember reinforcement brackets from the sillmembers.

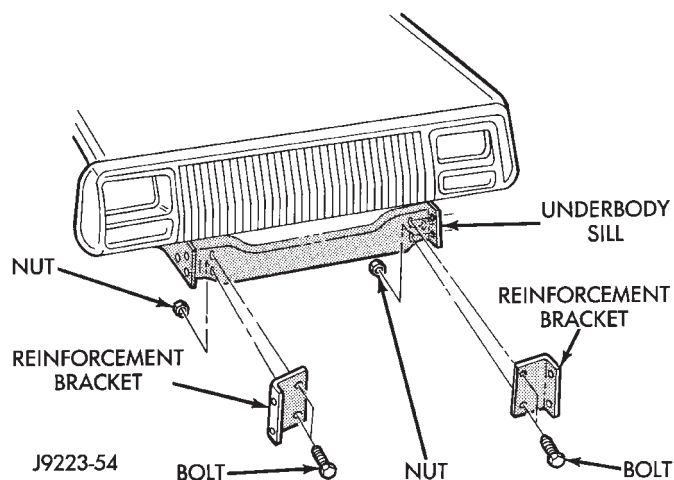

J9223-54

Fig. 11 Reinforcement Brackets

ASSEMBLY/INSTALLATION

(1) If removed, install the sill crossmember reinforcement brackets on the sillmembers (Fig. 11). Tighten bolts to 56 N·m (41 ft. lbs.) torque.

(2) If equipped, install the bumper support brackets and bumper guards on the bumper rail. Tighten hardware in the sequence indicated in (Fig. 6). Tighten the locknuts with 20 N·m (15 ft. lbs.) torque. Tighten bolts to 56 N·m (41 ft. lbs.) torque.

(3) If not equipped with bumper guards, install the bumper support brackets on the bumper rail. Tighten bolts to 56 N·m (41 ft. lbs.) torque.

(4) Install tow hooks. Tighten nuts with 100 N·m (74 ft. lbs.) torque.

(5) Install the bumper end caps on the bumper rail. Tighten nuts with 8 N·m (72 in. lbs.) torque.

(6) Install the license plate bracket on the bumper rail. Tighten the nuts securely.

(7) Install the fog lamps on the bumper rail. Tighten the nuts to 20 N·m (15 ft. lbs.) torque.

(8) If removed, install the vacuum reservoir(s) on the bumper rail. Tighten the retaining screws and bolts to 8 N·m (72 in. lbs.) torque.

(9) Position and support the bumper at the front of the vehicle.

(10) Attach the bumper support brackets to the right and left sillmembers and reinforcement brackets. Tighten screws and bolts to 56 N·m (41 ft. lbs.) torque.

(11) Install the Torx-head bolts and locknuts that attach the tow hook straps to the underbody sillmember. Tighten locknuts with 30 N·m (22 ft. lbs.) torque.

Install the steering gear skid plate and screws after the left tow hook strap has been installed.

(12) Connect the fog lamp wire harness connectors.

(13) Connect the vacuum reservoir tube harness connectors.

(14) Remove the bumper support.

FRONT TOW HOOKS

If a tow hook must be replaced or removed only for service access, remove the nuts and bolts that attach it to the bumper support bracket. When installing a tow hook, tighten nuts with 100 N·m (74 ft. lbs.) torque.

If a tow hook/bumper support bracket must be replaced, refer to the following removal and installation procedures.

REMOVAL

If equipped with a brush guard, refer to the Brush Guard Removal within Group 23, Body Components.

(1) Disconnect the fog lamp wire harness connectors, if equipped.

(2) Disconnect the vacuum reservoir tube harness connectors.

(3) Support the bumper.

(4) Remove the bolts that attach the bumper support brackets to the right and left sillmembers.

(5) Remove the locknuts and Torx-head bolts that attach the tow hook straps to the underbody sillmember.

The retaining screws and the steering gear skid plate must be removed before the left strap can be removed from the sillmember.

(6) Detach the tow hook straps from the sillmember.

(7) Remove the support and the bumper from the vehicle.

(8) Remove the nuts and bolts that attach the tow hooks to the bumper support brackets.

(9) Remove the tow hook from the bumper support bracket.

(10) Remove the support bracket from the bumper rail.

INSTALLATION

(1) Install the bumper guard and bumper support bracket on the bumper rail. Tighten the retaining hardware in the sequence indicated in Figure 7. Tighten locknuts to 20 N·m (15 ft. lbs.) torque. Tighten bolts to 56 N·m (41 ft. lbs.) torque.

(2) If not equipped with bumper guards, install the bumper support bracket on the bumper rail. Tighten bolts to 56 N·m (41 ft. lbs.) torque.

(3) Position the tow hook at the support bracket. Install the bolts and nuts that attach tow hook to the bumper support bracket. Tighten nuts to 100 N·m (74 ft. lbs.) torque.

(4) Position and support the bumper at the front of the vehicle.

(5) Attach the bumper support brackets to the right and left sillmembers and reinforcement brackets. Tighten screws and bolts to 56 N·m (41 ft. lbs.) torque.

(6) Install the Torx-head bolts and locknuts that attach the tow hook straps to the underbody sillmember. Tighten locknuts to 30 N·m (22 ft. lbs.) torque.

Install the steering gear skid plate and screws after the left tow hook strap has been installed.

(7) Connect the fog lamp wire harness connectors. Connect the vacuum reservoir tube harness connectors.

(8) Remove the bumper support.

REAR BUMPER

REMOVAL

(1) For vehicles equipped with a trailer hitch, remove the hitch before removing the bumper. If necessary, refer to the removal procedure within Group 23, Body Components.

(2) Raise and support the rear of the vehicle.

(3) Support the bumper.

(4) Remove the bolts that attach the bumper support brackets to the sill crossmember (Fig. 12).

(5) Remove the support and the rear bumper from the vehicle.

(6) Remove the bumper support brackets and splash shield the bumper, if necessary (Fig. 13).

(7) Remove the bumper end caps (Fig. 14) and bumper guards from the bumper (Fig. 15), if necessary.

INSTALLATION

(1) As applicable, install the splash shield and bumper support brackets, the bumper end caps and the bumper guards.

(2) Tighten the bumper support bolts to 56 N·m (41 ft. lbs.).

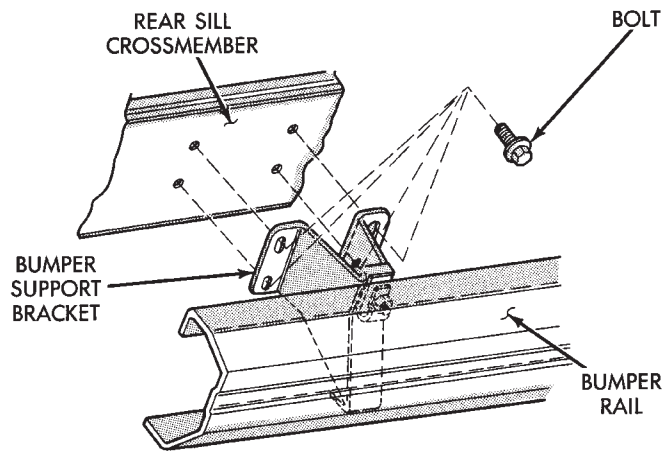

Fig. 12 Rear Bumper Removal/Installation—XJ Vehicles

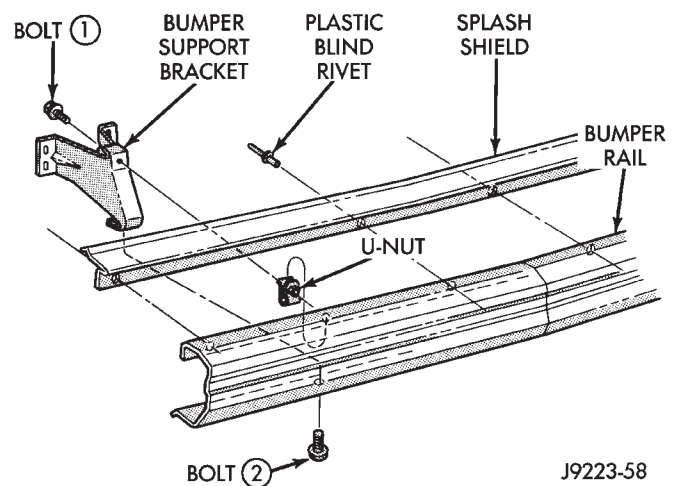

Fig. 13 Bumper Bracket & Splash Shield Removal/Installation—XJ Vehicles

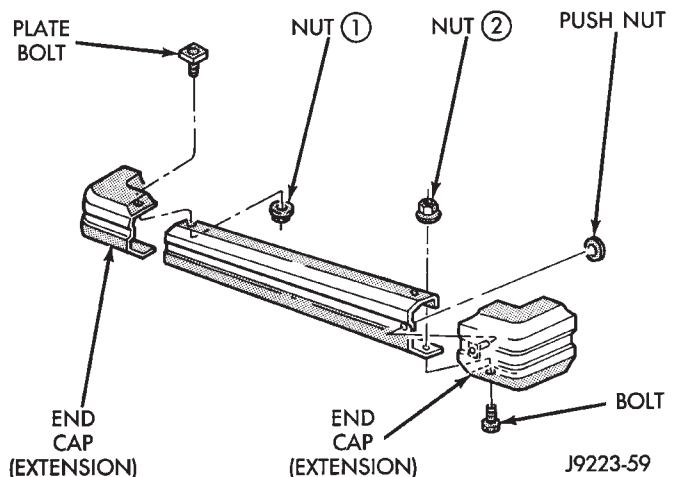

Fig. 14 Bumper End Cap Removal/Installation—XJ Vehicles

(3) Tighten the nuts in the sequence depicted in Figure 14. Tighten the bumper end cap plate bolt

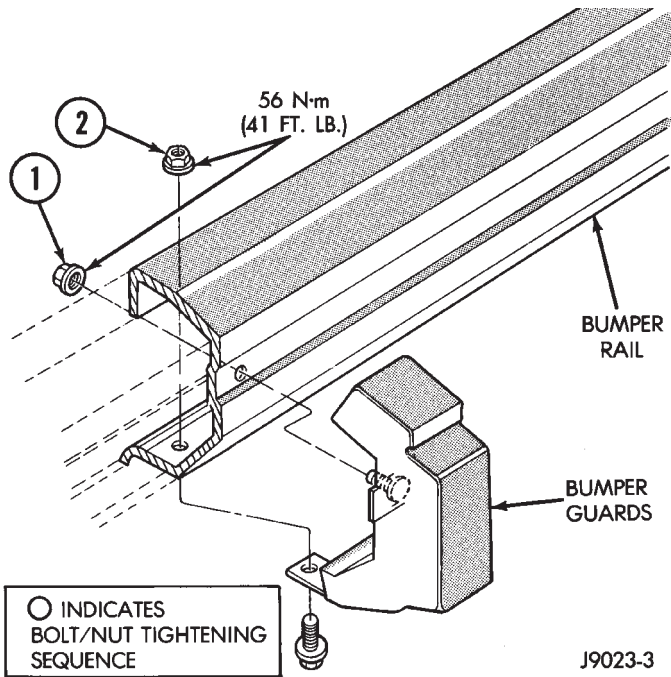

Fig. 15 Bumper Guard Removal/Installation—XJ Vehicles

nuts to 22 N·m (16 ft. lbs.) torque. Tighten the lower bolt nuts to 8 N·m (6 ft. lbs.) torque.

(4) If applicable, tighten the bumper guard bolts/nuts to 56 N·m (41 ft. lbs.).

(5) Position and support the bumper with the bracket holes aligned with the sill crossmember holes. Install the bracket-to-crossmember bolts. Tighten the bolts to 42 N·m (31 ft. lbs.) torque.

(6) If removed, install the trailer hitch. If necessary, refer to the installation procedure within Group 23, Body Components.

REAR TOW HOOK

REMOVAL

(1) Remove the bolts that attach tow hook bracket to the frame rail and reinforcement bracket (Fig. 16).

The reinforcement bracket is held on the

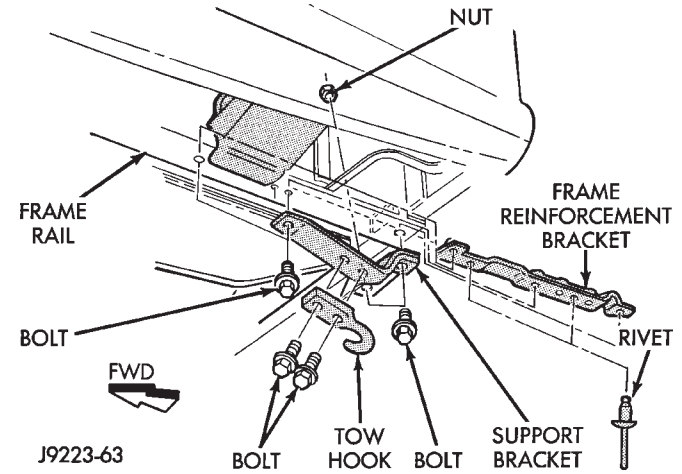

Fig. 16 Rear Tow Hook—XJ Vehicles

frame rail with two blind rivets.

(2) Remove the bracket and tow hook from frame rail.

INSTALLATION

(1) Position bracket and tow hook on the frame rail.

(2) Install bolts that attach tow hook bracket to frame rail and reinforcement bracket. Tighten bolts to 75 N·m (55 ft. lbs.) torque.

FRAME

INDEX

	page		page
Frame Dimensions	13	Generator Splash Shield	13
Frame Repairs	13	Safety Precautions and Warnings	10
Frame Straightening	13	Tow Hooks	13
Fuel Tank Skid Plate	15	Transfer Case Skid Plate	15
General Information	10		

SAFETY PRECAUTIONS AND WARNINGS

WARNING: USE EYE PROTECTION WHEN GRINDING OR WELDING METAL, SERIOUS EYE INJURY CAN RESULT.

BEFORE PROCEEDING WITH FRAME REPAIR INVOLVING GRINDING OR WELDING, VERIFY THAT VEHICLE FUEL SYSTEM IS NOT LEAKING OR IN CONTACT WITH REPAIR AREA, PERSONAL INJURY CAN RESULT.

DO NOT ALLOW OPEN FLAME TO CONTACT PLASTIC BODY PANELS. FIRE OR EXPLOSION CAN RESULT.

WHEN WELDED FRAME COMPONENTS ARE REPLACED, 100% PENETRATION WELD MUST BE ACHIEVED DURING INSTALLATION. IF NOT, DANGEROUS OPERATING CONDITIONS CAN RESULT.

STAND CLEAR OF CABLES OR CHAINS ON PULLING EQUIPMENT DURING FRAME STRAIGHTENING OPERATIONS, PERSONAL INJURY CAN RESULT.

DO NOT VENTURE UNDER A HOISTED VEHICLE THAT IS NOT SUPPORTED ON SAFETY STANDS, PERSONAL INJURY CAN RESULT.

CAUTION: Do not reuse damaged fasteners, quality of repair would be suspect.

Do not drill holes in top or bottom frame rail flanges, frame rail failure can result.

Do Not use softer than Grade 3 bolts to replace production fasteners, loosening or failure can result.

When using heat to straighten frame components do not exceed 566°C (1050°F), metal fatigue can result.

Welding the joints around riveted cross members and frame side rails can weaken frame

GENERAL INFORMATION

The Jeep YJ (Fig. 1) frame is the structural center of the vehicle. In addition to supporting the body and payload, the frame provides a station for the engine. The vehicle body is attached to the frame with hold-downs (Fig. 2 and 3).

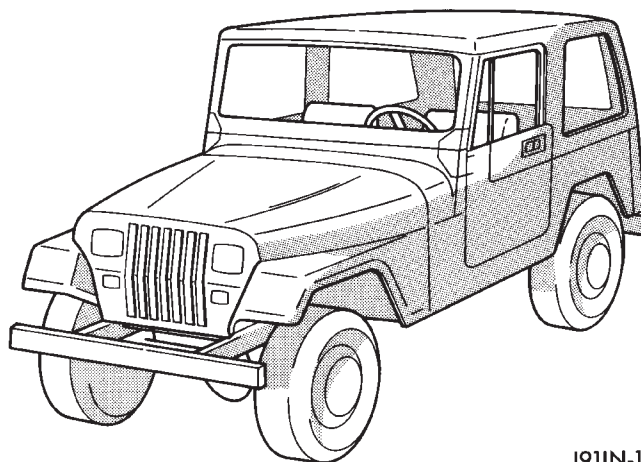

J911N-10

Fig. 1 Jeep—YJ

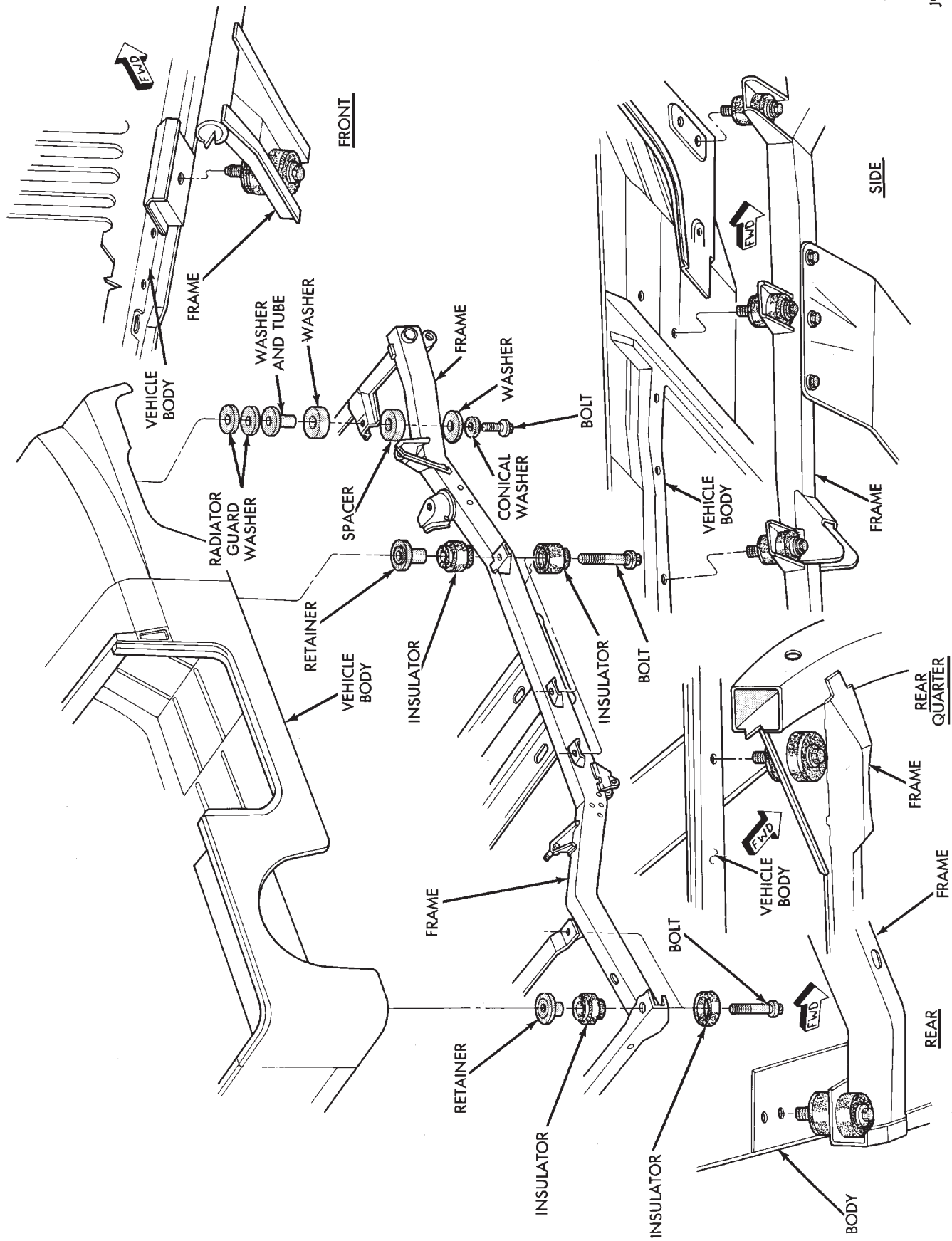
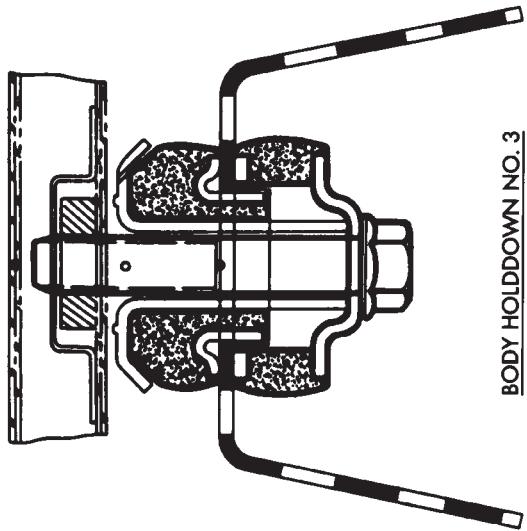
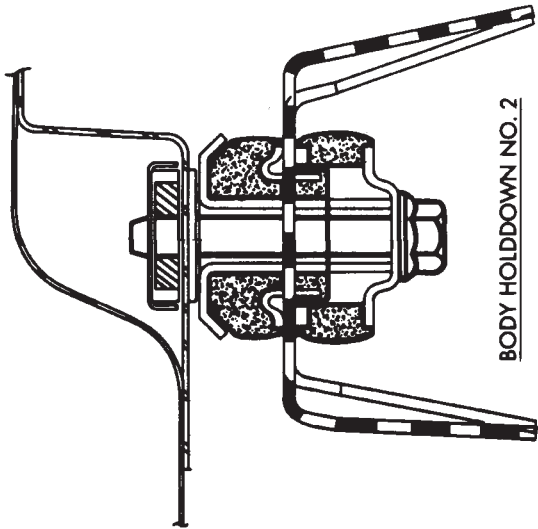

Fig. 2 YJ Body & Frame



BODY HOLDDOWN NO. 3



BODY HOLDDOWN NO. 2

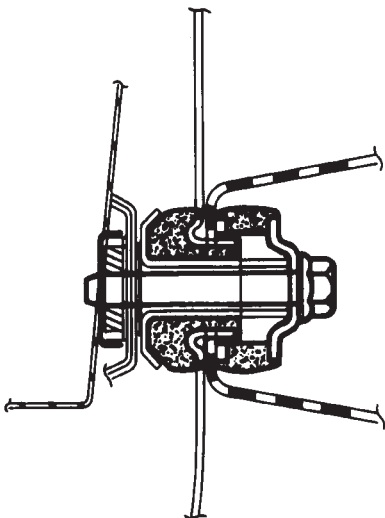

BODY HOLDDOWN NO. 1

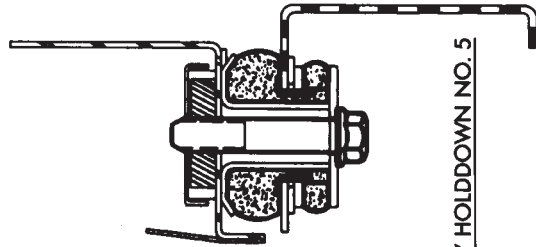

BODY HOLDDOWN NO. 5

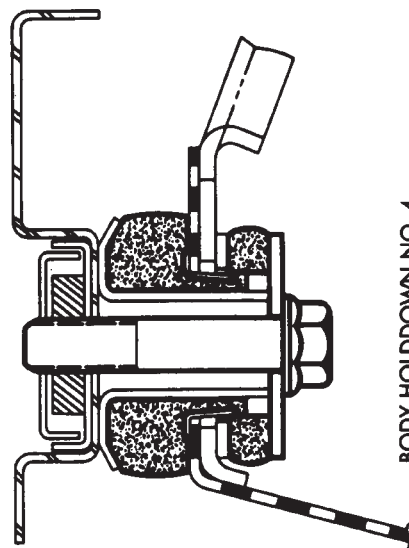

BODY HOLDDOWN NO. 4

J8913-8

Fig. 3 Body HoldDowns—YJ Vehicles

The frame is constructed of high-strength channel steel siderails and crossmembers. The crossmembers join the siderails and retain them in alignment in relation to each other. This provides resistance to frame twists and strains.

FRAME STRAIGHTENING

When necessary, a conventional frame that is bent or twisted can be straightened by application of heat. The temperature must not exceed 566°C (1050°F). The use of a specially designed heat crayon can determine the desired temperature. Excessive heat will decrease the strength of the metal and result in a weakened frame.

Welding the joints around riveted cross members and frame side rails is not recommended.

A straightening repair process should be limited to frame members that are not severely damaged.

FRAME REPAIRS

DRILLING HOLES

Do not drill holes in frame side rail top and bottom flanges, metal fatigue can result causing frame failure. Holes drilled in the side of the frame rail must be at least 38 mm (1.5 in.) from the top and bottom flanges.

Additional drill holes should be located away from existing holes.

WELDING

Use MIG, TIG or arc welding equipment to repair welded frame components.

Frame components that have been damaged should be inspected for cracks before returning the vehicle to use. If cracks are found in accessible frame components perform the following procedures.

(1) Drill a hole at each end of the crack with a 3 mm (0.125 in.) diameter drill bit.

(2) Using a suitable die grinder with 3 inch cut off wheel, V-groove the crack to allow 100% weld penetration.

(3) Weld the crack.

(4) If necessary when a side rail is repaired, grind the weld smooth and install a reinforcement channel (Fig. 4) over the repaired area.

If a reinforcement channel is required, the top and bottom flanges should be 0.250 inches narrower than the side rail flanges. Weld only in the areas indicated (Fig. 4).

FRAME FASTENERS

Bolts, nuts and rivets can be used to repair frames or to install a reinforcement section on the frame. Bolts can be used in place of rivets. When replacing rivets with bolts, install the next larger size diameter bolt to assure proper fit. If necessary, drill the hole out just enough to receive the bolt.

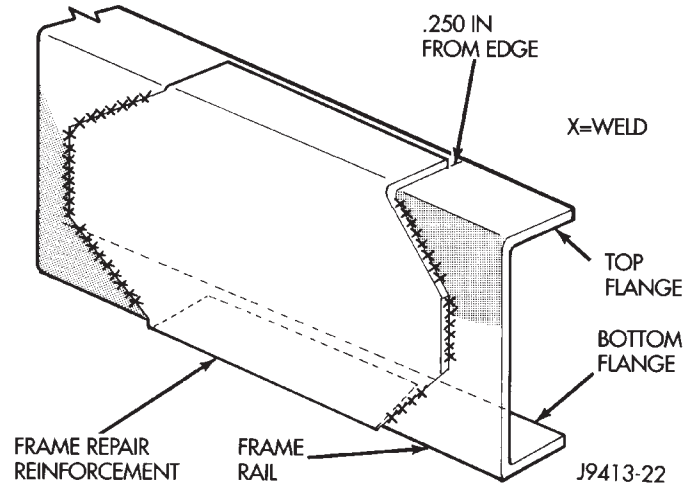

Fig. 4 Frame Reinforcement

Conical-type washers are preferred over the splitting type lock washers. Normally, grade-5 bolts are adequate for frame repair. **Grade-3 bolts or softer should not be used.** Tightening bolts/nuts with the correct torque, refer to the Introduction Group at the front of this manual for tightening information.

FRAME DIMENSIONS

Frame dimensions are listed in millimeter scale. All dimensions are from center to center of Principal Locating Point (PLP), or from center to center of PLP and fastener location (Fig. 5).

TOW HOOKS

REMOVAL

- (1) Remove the two bolts that attach the tow hook to the bumper rail and to the frame rail.
- (2) Remove the tow hook.

INSTALLATION

- (1) Position the tow hook on the bumper rail and frame rail.
- (2) Install the attaching bolts. Tighten the bolts to 102 N·m (75 ft. lbs.) torque.

GENERATOR SPLASH SHIELD

REMOVAL

- (1) Remove the shield retaining nut and washer (Fig. 6) from the engine oil pan stud (2.5L engines only).
- (2) Pry the serrated retainers from the frame rail holes at each side of the vehicle.
- (3) Pry the serrated retainers from the fan shroud holes (Fig. 6).
- (4) Remove the shield from the vehicle.

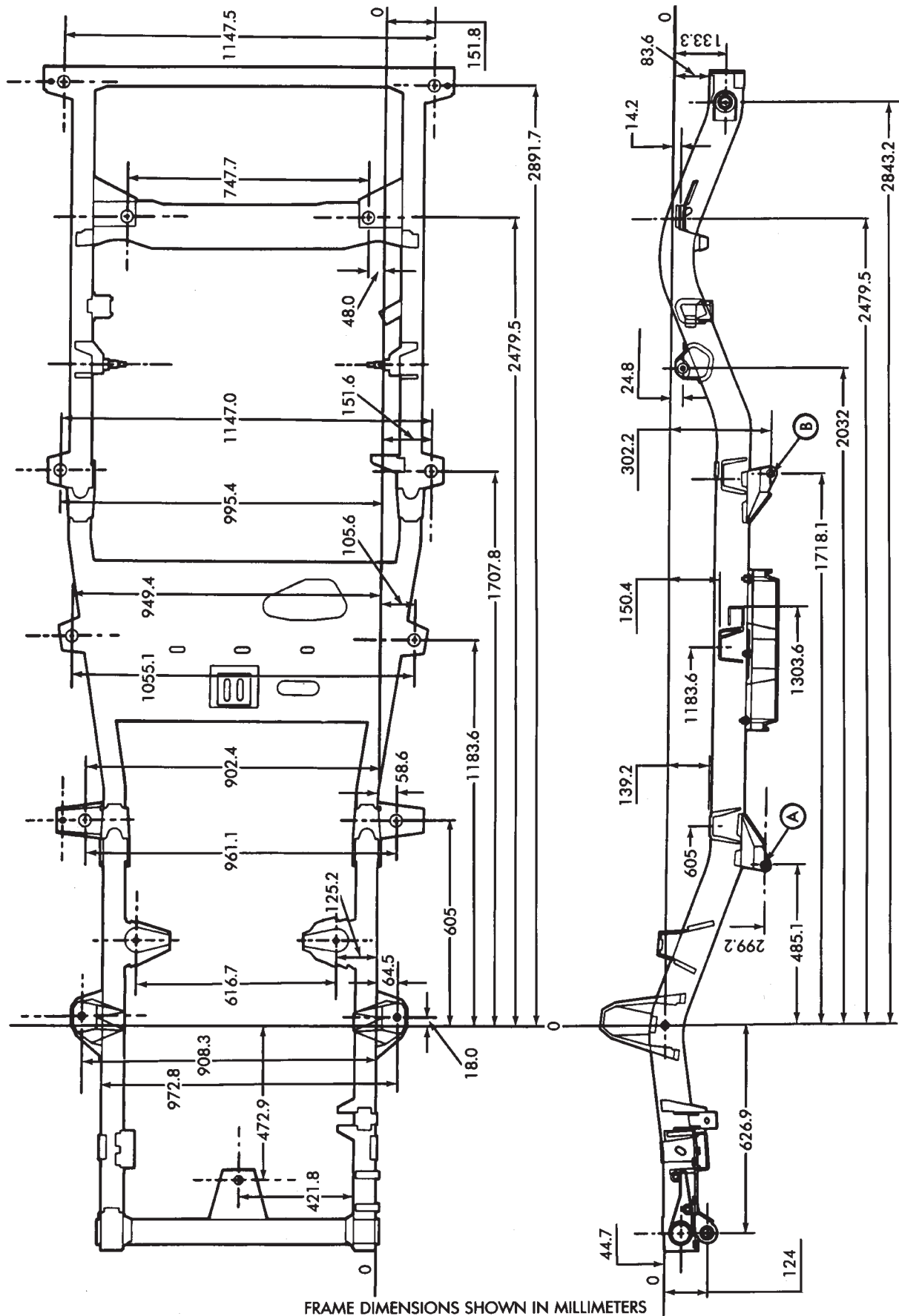

FRAME DIMENSIONS SHOWN IN MILLIMETERS

J8913-7

Fig. 5 Frame Alignment Dimensions—YJ Vehicles

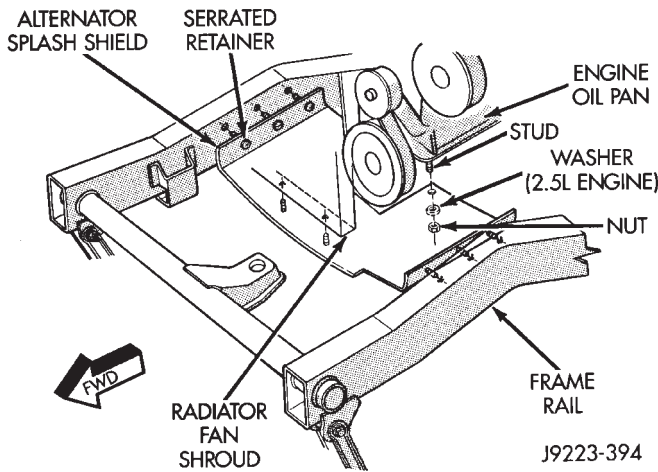

Fig. 6 Generator Splash Shield

INSTALLATION

- (1) Position the generator splash shield at the fan shroud and frame rails.
- (2) Force the serrated retainers into the fan shroud holes.
- (3) Force the serrated retainers into the frame rail holes at each side of the vehicle.

TRANSFER CASE SKID PLATE

REMOVAL

- (1) Raise and support the transmission.
- (2) Remove the nuts that attach the transmission support cushion and torque bracket to the skid plate (Fig. 7).

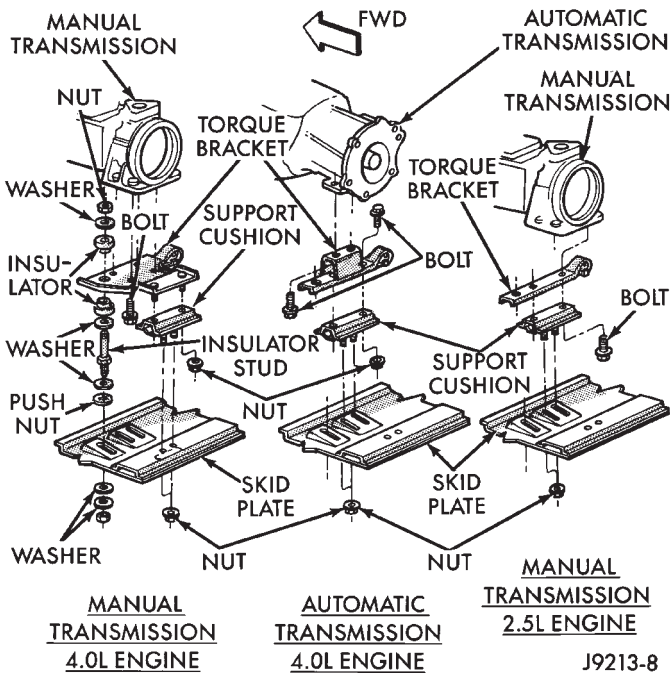

Fig. 7 Transfer Case Skid Plate

- (3) Separate the transmission support cushion from the skid plate.

- (4) Remove the nuts and bolts that attach the skid plate to the frame.
- (5) Remove the skid plate from the vehicle.

INSTALLATION

- (1) Position the skid plate at the frame and transmission support cushion.
- (2) Attach the skid plate to the frame.
- (3) Install the nuts that attach the transmission support cushion and torque bracket to the skid plate. Tighten the nuts to 56 N·m (41 ft. lbs.) torque.
- (4) Remove the support and lower the transmission.

FUEL TANK SKID PLATE

REMOVAL

- (1) Position a support under the fuel tank skid plate.
- (2) Remove the nuts that attach the skid plate to the straps and to the crossmembers (Fig. 8).

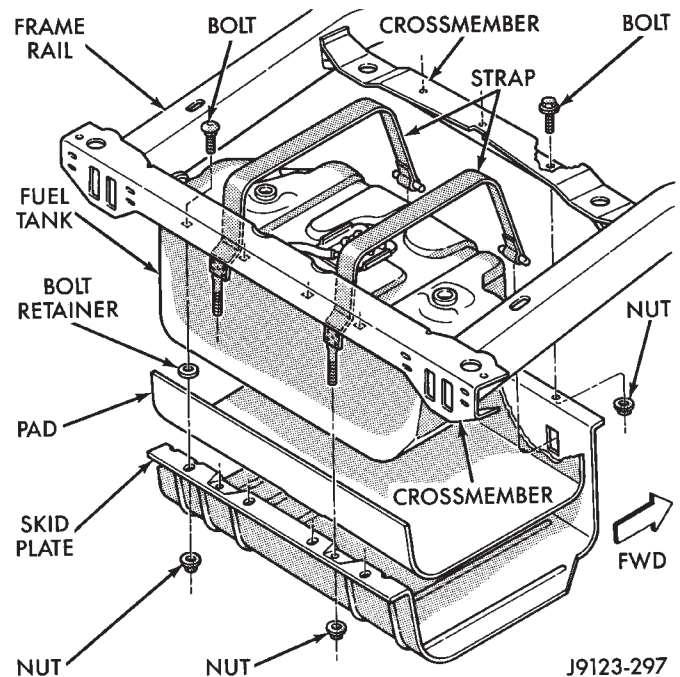

Fig. 8 Fuel Tank Skid Plate

- (3) Separate the fuel tank strap from the skid plate.
- (4) Support the fuel tank and remove the skid plate and the pad from the vehicle.

INSTALLATION

- (1) Attach the skid plate to the fuel tank strap.
- (2) Position and support the pad and skid plate under the fuel tank.
- (3) Install the nuts to attach the skid plate to the straps and to the frame crossmembers. Tighten the fuel tank strap nuts to 5 N·m (40 in. lbs.) torque. Tighten the skid plate-to-crossmember nuts with 16 N·m (138 in. lbs.) torque.
- (4) Remove the support from under the skid plate.

BUMPERS

INDEX

	page		page
Frame Crossmember Cover	16	Rear Bumper	16
Front Bumper	16	Service Information	16

SERVICE INFORMATION

In some cases, components in the following procedures either support, or are hidden by other components.

FRONT BUMPER

The YJ front bumper is a one-piece rail (Fig. 1). A front crossmember cover (Fig. 1) is also installed on all YJ vehicles.

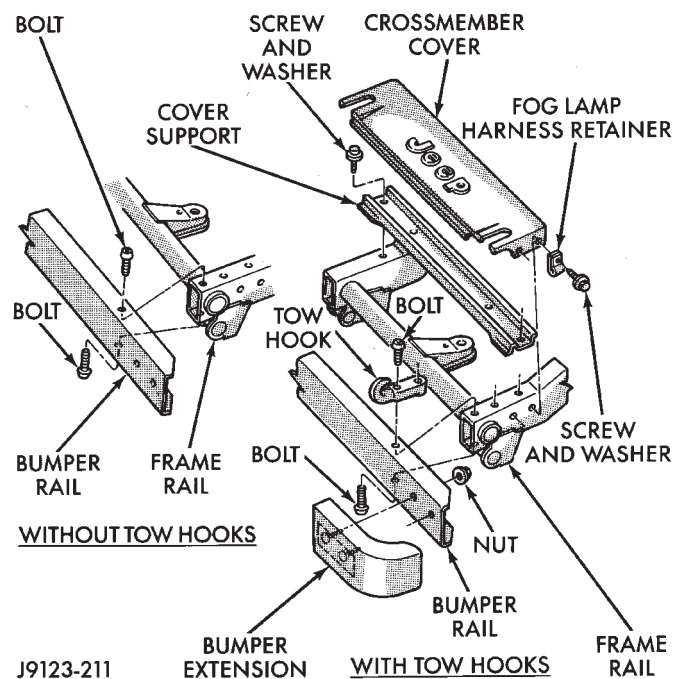

Fig. 1 Front Bumper Rail, Crossmember Cover & Tow Hooks

BUMPER REMOVAL

- (1) Disconnect and remove the fog lamps, if equipped.
- (2) Remove the nuts and bolts that retain the bumper extensions to the bumper rail and remove the extensions.
- (3) Remove the nuts and bolts that attach the bumper rail/tow hooks to the frame rails.
- (4) Separate the bumper rail from the frame rails.

BUMPER INSTALLATION

- (1) Position the front bumper on the frame rails.

- (2) Install the bolts and attach the front bumper rail (and tow hooks, if equipped) to the frame rails.
- (3) Tighten the bolts to 102 N·m (75 ft. lbs.) torque.
- (4) Position the bumper extensions on the bumper rail and install the retaining bolts.
- (5) Tighten the bolts to 104 N·m (77 ft. lbs.) torque.
- (6) Install the fog lamps, if equipped.

FRAME CROSSMEMBER COVER

REMOVAL

- (1) Remove the screws that attach the crossmember cover and support to the frame rails.
- (2) Remove the crossmember cover and support from the frame rails.

INSTALLATION

- (1) Position the support and crossmember cover on the frame rails.
- (2) Install the attaching screws.
- (3) Tighten the screws to 8 N·m (72 in. lbs.) torque.

REAR BUMPER

When equipped with a spare tire carrier attached to the tailgate, a rear bumperette is attached to the frame (Fig. 2 and 3).

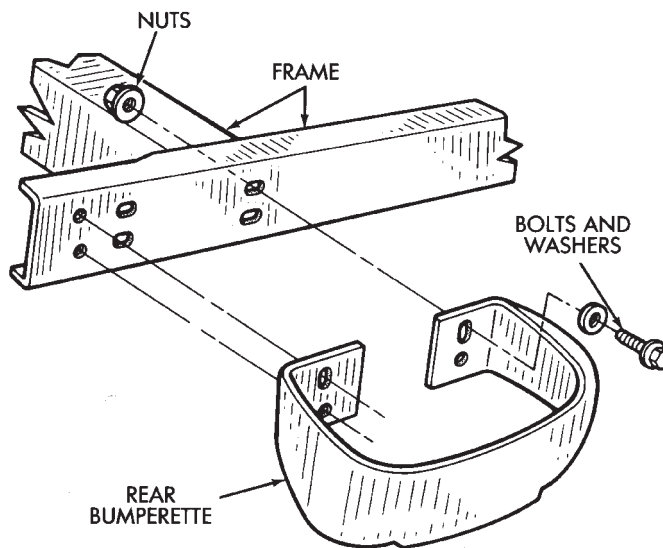

Fig. 2 Rear Bumperette

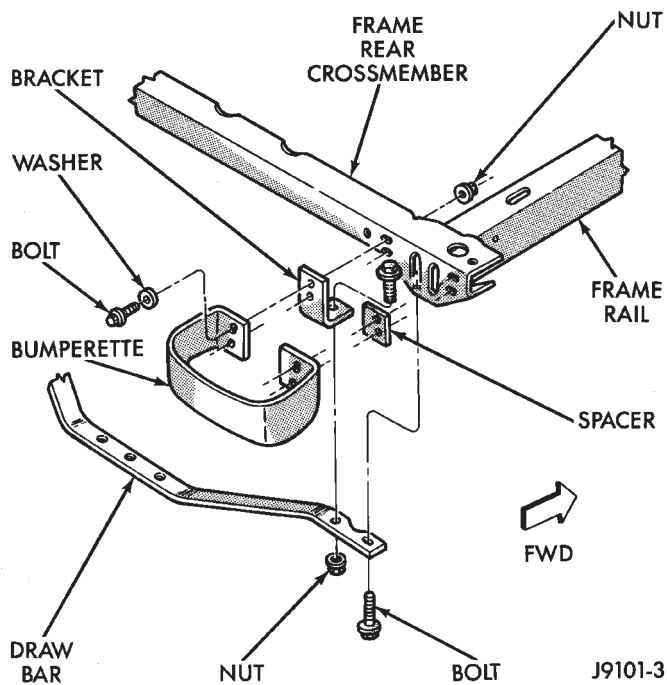

Fig. 3 Rear Bumperette & Draw Bar

BUMPERETTE AND DRAW BAR REMOVAL

(1) Remove the bumperette and draw bar retaining nuts, bolts and washers from the frame rear crossmember (Fig. 2 and 3).

(2) Remove the bumperettes, spacers, brackets and draw bar from the rear crossmember.

INSTALLATION

(1) Position the spacers, brackets, draw bar and bumperettes on the rear crossmember.

(2) Install the retaining nuts, bolts and washers in the frame rear crossmember. Tighten the retaining nuts and bolts with 3 N·m (30 in. lbs.) torque.

