

# PROPELLER SHAFTS

## CONTENTS

	page		page
GENERAL INFORMATION .....	1	TORQUE SPECIFICATIONS .....	15
SERVICE DIAGNOSIS .....	3	UNIVERSAL JOINT REPLACEMENT .....	10
SERVICE PROCEDURES .....	8		

## GENERAL INFORMATION

### PROPELLER SHAFTS

The function of a propeller shaft is to transmit power from one point to another. The shaft is designed to send torque from the transmission (transfer case on 4WD vehicles) to the axle (Fig. 1,2).

The propeller shaft must operate through constantly changing relative angles between the transmission and axle. It must also be capable of changing length while transmitting torque. The axle rides suspended by springs in a floating motion. The propeller

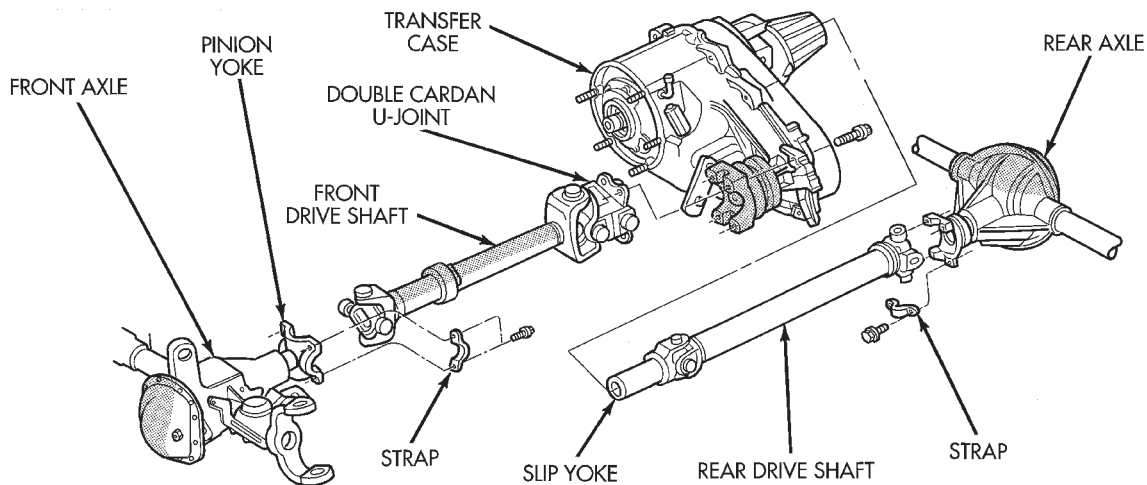

J9516-5

**Fig. 1 Propeller Shafts XJ**

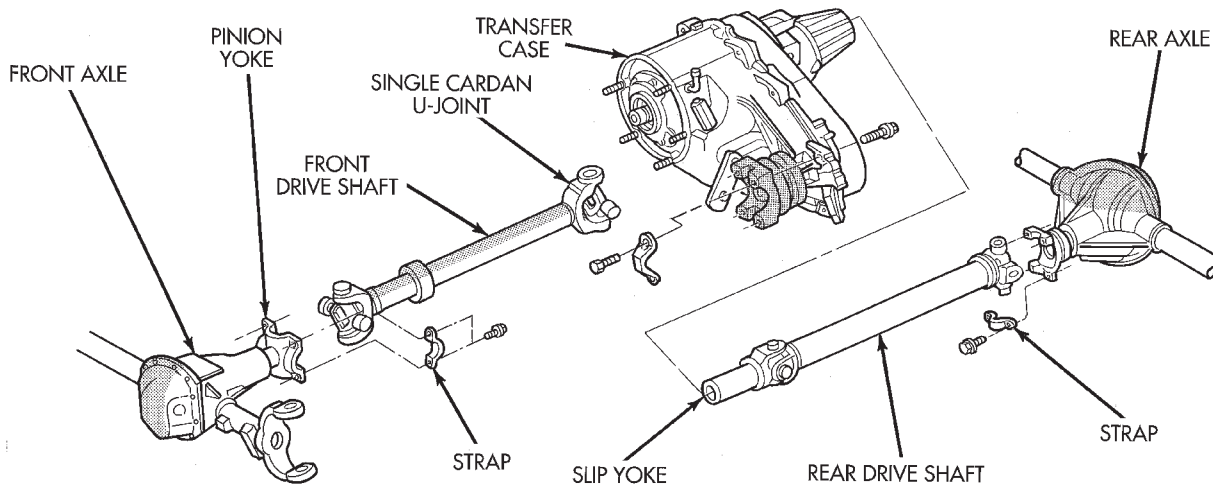

J9516-6

**Fig. 2 Propeller Shafts YJ**

shaft must be able to change operating angles when going over various road surfaces. This is done through universal joints, which permit the propeller shaft to operate at different angles. The slip joints (or yokes) permit contraction or expansion (Fig. 1,2).

Tubular propeller shafts are balanced by the manufacturer with weights spot welded to the tube.

The propeller shaft is designed and built with the yoke lugs in line with each other which is called phasing. This design produces the smoothest running condition, an out of phase shaft can cause a vibration.

**Before undercoating a vehicle, the propeller shaft and the U-joints should be covered. This will prevent the undercoating from causing an unbalanced condition and vibration.**

**CAUTION:** Use exact replacement hardware for attaching the propeller shafts. The specified torque must always be applied when tightening the fasteners.

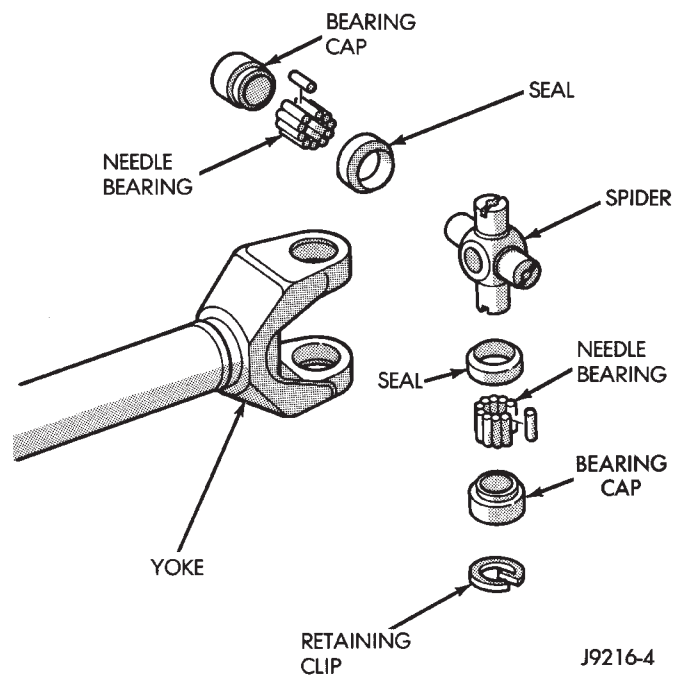

**Fig. 3 Single Cardan Universal Joint**

**UNIVERSAL JOINTS**

Two different types of U-joints are used with the propeller shafts:

- Single cardan U-joint (Fig. 3)
- Double cardan U-joint (Fig. 4)

**LUBRICATION**

The factory installed U-joints are lubricated for the life of the vehicle and do not need re-lubrication. All U-joints should be inspected for leakage and damage each time the vehicle is serviced. If seal leakage or damage exists, the U-joint should be replaced.

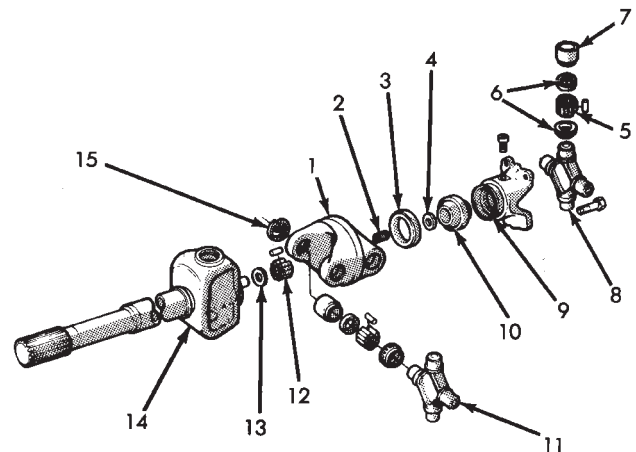

1. LINK YOKE
2. SOCKET SPRING
3. SOCKET BALL RETAINER
4. THRUST WASHER
5. NEEDLE BEARINGS
6. SEAL
7. BEARING CAP
8. REAR SPIDER
9. SOCKET YOKE
10. SOCKET BALL
11. FRONT SPIDER
12. SOCKET NEEDLE BEARINGS
13. THRUST WASHER
14. DRIVE SHAFT YOKE
15. RETAINING CLIP

J8916-2

**Fig. 4 Double Cardan (CV) Universal Joint**

SERVICE DIAGNOSIS

INDEX

	page		page
Runout .....	4	Universal Joint Angle Measurement .....	4
Unbalance .....	3	Vibration .....	3

**VIBRATION**

Tires that are out-of-round or wheels that are unbalanced will cause a low frequency vibration. Refer to Group 22, Wheels and Tires for additional information.

Brake drums that are unbalanced will cause a harsh, low frequency vibration. Refer to Group 5, Brakes for additional information.

Driveline vibration can also result from loose or damaged engine mounts. Refer to Group 21, Transmissions for additional information.

Propeller shaft vibration will increase as the vehicle speed is increased. A vibration that occurs within a specific speed range is not caused by propeller shaft unbalance. Defective universal joints or an incorrect propeller shaft angle are usually the cause.

**UNBALANCE**

If propeller shaft unbalance is suspected, it can be verified with the following procedure.

**Removing and re-indexing the propeller shaft 180° may eliminate some vibrations.**

- Clean all the foreign material from the propeller shaft and the universal joints.

- Inspect the propeller shaft for missing balance weights, broken welds, and bent areas. **If the propeller shaft is bent, it must be replaced.**

- Ensure the universal joints are not worn, are properly installed, and are correctly aligned with the shaft.

- Check the universal joint clamp screws torque

(1) Raise the vehicle.

(2) Remove the wheel and tires assembly. Install the wheel lug nuts to retain the brake drums.

(3) Mark and number the shaft six inches from the yoke end at four positions 90° apart.

(4) Run and accelerate the vehicle until vibration occurs. Note the intensity and speed the vibration occurred. Stop the engine.

(5) Install a screw clamp at position 1 (Fig. 1).

(6) Start the engine and re-check for vibration. If there is little or no change in vibration, move the clamp to one of the other three positions. Repeat the vibration test.

(7) If there is no difference in vibration at the other positions, the vibration may not be propshaft unbalance.

DRIVELINE VIBRATION

Drive Condition	Possible Cause	Correction
<b>PROPELLER SHAFT</b>	a. Undercoating or other foreign material on shaft. b. Loose U-joint clamp screws. c. Loose or bent U-joint yoke or excessive runout. d. Incorrect drive line angularity. e. Rear spring center bolt not in seat. f. Worn U-joint bearings. g. Propeller shaft damaged (bent tube) or out of balance. h. Broken rear spring. i. Excessive runout or unbalanced condition. j. Excessive drive pinion gear shaft yoke runout.	a. Clean exterior of shaft and wash with solvent. b. Tighten screws properly. c. Install replacement yoke. d. Correct angularity e. Loosen spring U-bolts and seat center bolts. f. Replace U-joint. g. Install replacement propeller shaft. h. Replace rear spring. i. Reindex propeller shaft 180°, test and correct as necessary. j. Reindex propeller shaft 180° and evaluate.
<b>UNIVERSAL JOINT NOISE</b>	a. U-joint clamp screws loose. b. Lack of lubrication.	a. Tighten screws with specified torque. b. Replace U-joint.

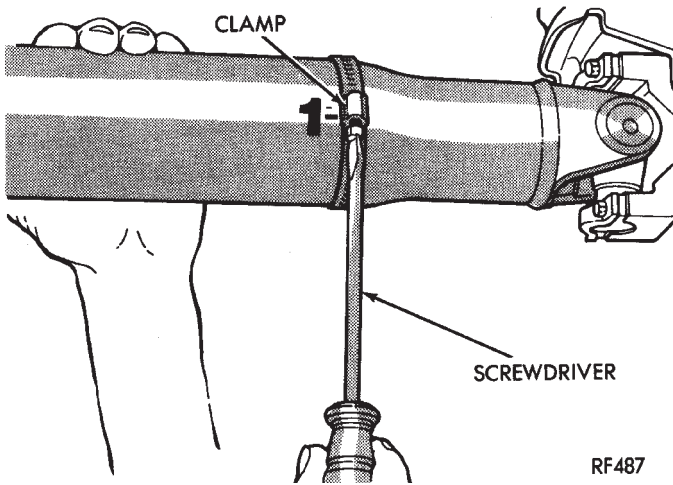

**Fig. 1 Clamp Screw At Position 1**

(8) If the vibration decreased, install a second clamp (Fig. 2) and repeat the test.

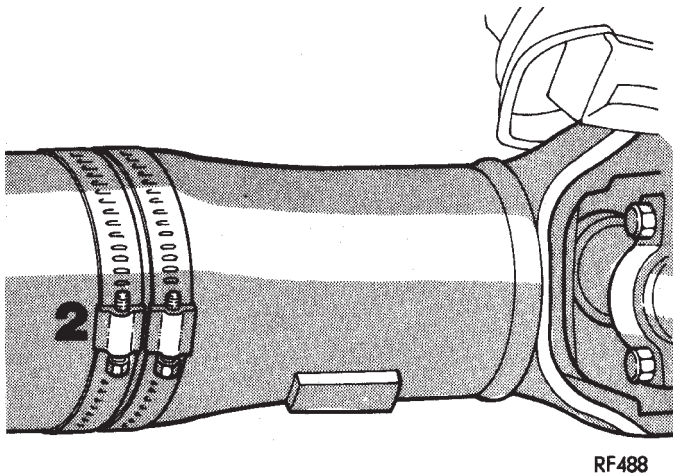

**Fig. 2 Two Clamp Screws At The Same Position**

(9) If the clamps cause an additional unbalance, separate the clamps (1/4 inch above and below the mark). Repeat the vibration test (Fig. 3).

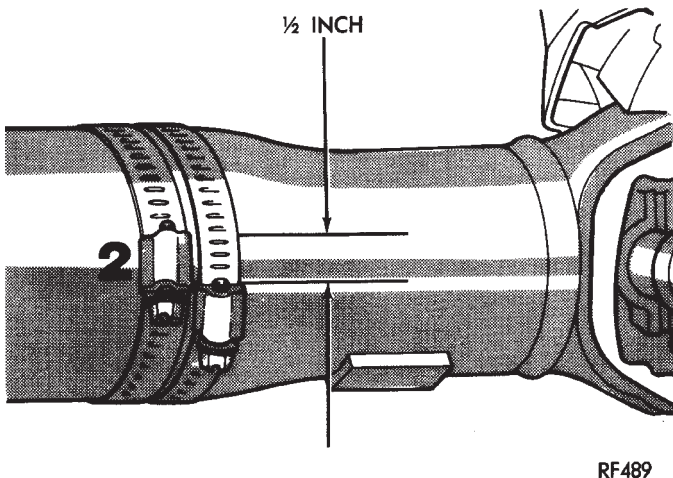

**Fig. 3 Clamp Screws Separated**

(10) Increase distance between the clamp screws and repeat the test until the amount of vibration is at the lowest level. Bend the slack end of the clamps so the screws will not loosen.

(11) Install the wheel and tires. Lower the vehicle.

(12) If the amount of vibration remains unacceptable, apply procedures at the front end of the propeller shaft.

**RUNOUT**

(1) Remove dirt, rust, paint, and undercoating from the propeller shaft surface. Areas where the dial indicator will contact the shaft must be clean.

(2) The dial indicator must be installed perpendicular to the shaft surface.

(3) Measure runout at the center and ends away from welds.

(4) Refer to Runout Specifications chart.

(5) Replace the propeller shaft if the runout exceeds the limit.

**RUNOUT SPECIFICATIONS**

Front of shaft . . . . .	0.010 in. (0.25 mm)
Center of shaft . . . . .	0.015 in. (0.38 mm)
Rear of shaft . . . . .	0.010 in. (0.25 mm)

NOTE: Measure front/rear runout approximately 3 inches (76 mm) from the weld seam at each end of the shaft tube for tube lengths over 30 inches. Under 30 inches the max. runout is 0.20 inch for full length of the tube.

J9116-15

**UNIVERSAL JOINT ANGLE MEASUREMENT**

**INFORMATION**

When two shafts come together at any common joint, the bend that is formed is called the operating angle. The larger the angle, the larger the amount of acceleration and deceleration of the joint. This speeding up and slowing down of the joint must be cancelled to produce a smooth power flow. This is done through phasing and proper universal joint working angles.

A propeller shaft is properly phased when the yoke ends are on the same plane or in line. A twisted shaft will throw the yokes out of phase and cause a noticeable vibration.

When taking universal joint angle measurements or checking phasing with two piece shafts, consider each shaft separately. On 4WD vehicles, the front shaft input (pinion shaft) angle has priority over the caster angle.

Ideally the driveline system should have;

- Angles that are in equal or opposite within 1 degree of each other
- Have a 3 degree maximum operating angle



- Have at least a 1/2 degree continuous operating (propeller shaft) angle

Engine speed (R.P.M.) is the main factor though in determining maximum allowable operating angles. As a guide to maximum normal operating angles refer to the chart listed (Fig. 4).

PROPELLER SHAFT R.P.M.	MAX. NORMAL OPERATING ANGLES
5000	3°
4500	3°
4000	4°
3500	5°
3000	5°
2500	7°
2000	8°
1500	11°

J9316-4

Fig. 4 Maximum Angles and R.P.M.

**INSPECTION**

Before measuring universal joint angles, the following must be done.

- Inflate all tires to correct pressure
- Check angles in the same loaded or unloaded condition as when the vibration occurred. Propshaft angles will change according to the amount of load in the vehicle. Always check angles in loaded and unloaded conditions.
- Check the condition of all suspension components and verify all fasteners are torqued to specifications.
- Check the condition of the engine and transmission mounts and verify all fasteners are torqued to specifications.

**MEASUREMENT**

To accurately check driveline alignment, raise and support the vehicle at the axles as level as possible. Allow the wheels and propeller shaft to turn. Remove any external bearing snap rings (if equipped) from universal joint so protractor base sits flat.

(1) Rotate the shaft until transmission/transfer case output yoke bearing is facing downward.

**Always make measurements from front to rear.**

(2) Place Inclinometer on yoke bearing (A) parallel to the shaft (Fig. 5). Center bubble in sight glass and record measurement.

**This measurement will give you the transmission or OUTPUT YOKE ANGLE (A).**

(3) Rotate propeller shaft 90 degrees and place Inclinometer on yoke bearing parallel to the shaft (Fig. 6). Center bubble in sight glass and record measurement. This measurement can also be taken at the rear end of the shaft.

**This measurement will give you the PROPELLER SHAFT ANGLE (C).**

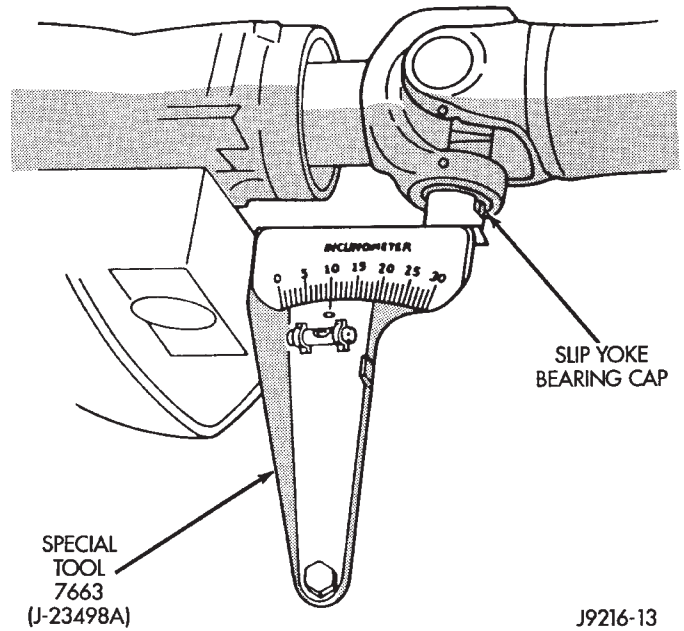

Fig. 5 Front (Output) Angle Measurement (A)

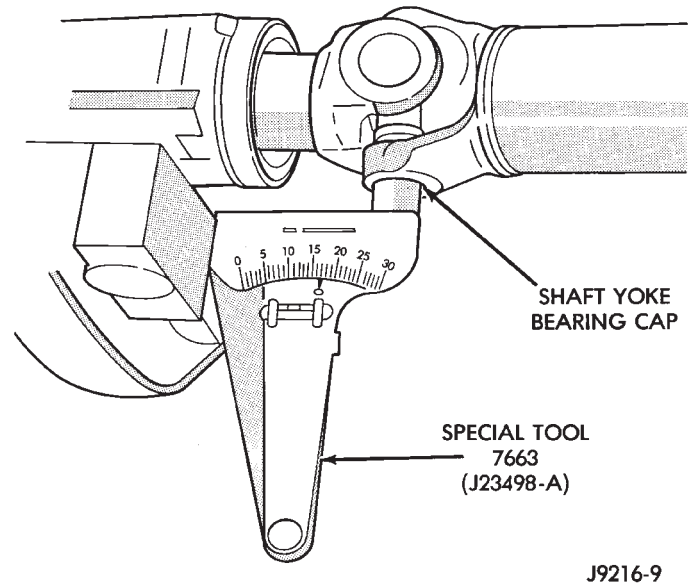

Fig. 6 Propeller Shaft Angle Measurement (C)

(4) Subtract smaller figure from larger (C minus A) to obtain transmission OUTPUT OPERATING ANGLE.

(5) Rotate propeller shaft 90 degrees and place Inclinometer on pinion yoke bearing parallel to the shaft (Fig. 7). Center bubble in sight glass and record measurement.

**This measurement will give you the pinion shaft or INPUT YOKE ANGLE (B).**

(6) Subtract smaller figure from larger (C minus B) to obtain axle INPUT OPERATING ANGLE.

Refer to rules given below and the example in (Fig. 8) for additional information.

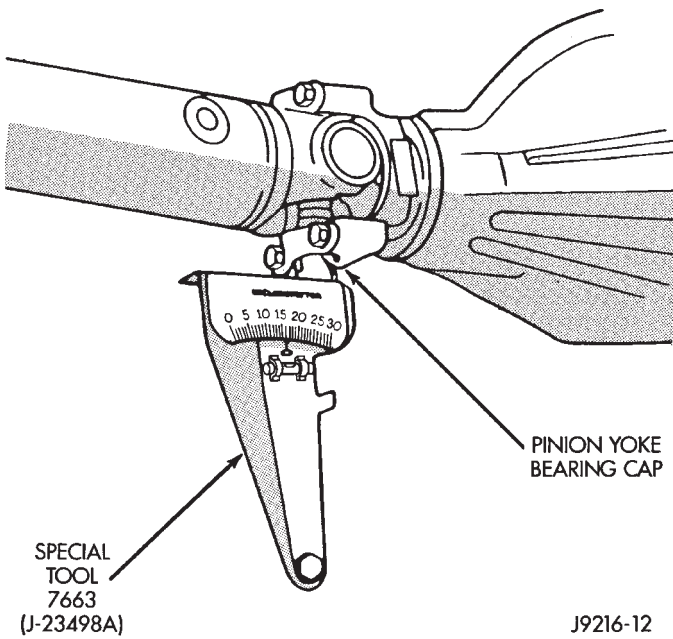
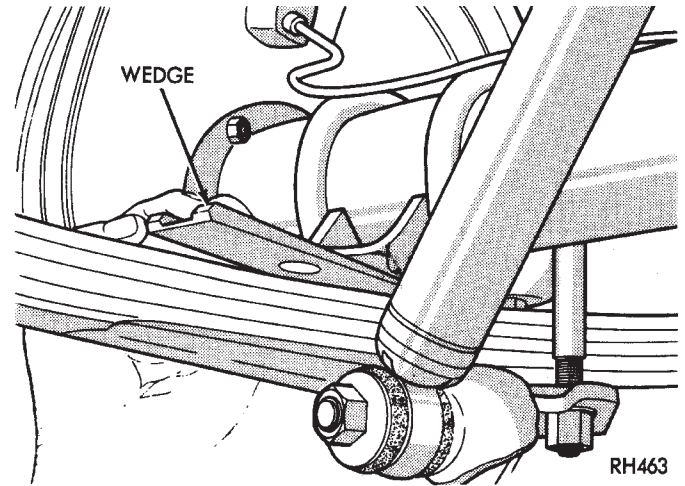

**Fig. 7 Rear (Input) Angle Measurement (B)**

- Good cancellation of u-joint operating angles (within 1°)
- Operating angles less than 3°
- At least 1/2 of one degree continuous operating (propeller shaft) angle

**ADJUSTMENT AT AXLE WITH LEAF SPRINGS**

Adjust the pinion shaft angle at the springs with tapered shims (Fig. 9). Install tapered shims between the springs and axle pad to correct the angle. Refer to Group 3, Rear Suspension and Axle for additional information.



**Fig. 9 Angle Adjustment at Leaf Springs**

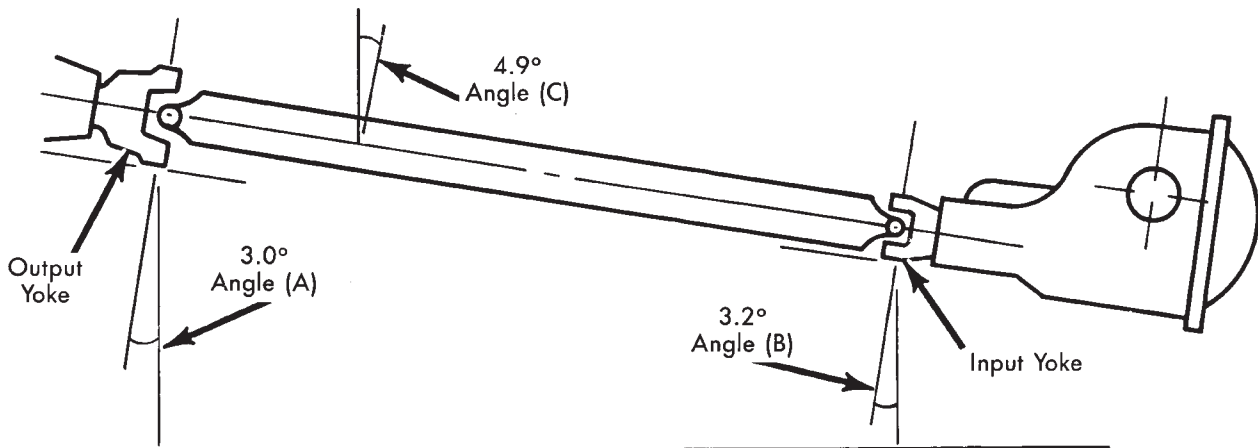

Horizontal Level

(A) Output Yoke = 3.0°  
 (C) Prop. Shaft = 4.9° or -3.0°

(B) Axle Input Yoke = 3.2°  
 (C) Prop. Shaft = 4.9° or -3.2°

Transmission Output Operating Angle 1.9°

Axle Input Operating Angle 1.7°

Trans. Output Operating Angle 1.9°  
 Axle Input Operating Angle -1.7°

Amount of U-Joint Cancellation 0.2°

J9316-3

**Fig. 8 Universal Joint Angle Example**

**ADJUSTMENT—XJ FRONT SHAFT**

Adjust the pinion gear angle at the lower suspension arms with shims (Fig. 10). Adding shims will decrease the pinion gear shaft angle but will increase the caster angle. The pinion gear shaft angle has priority over the caster angle.

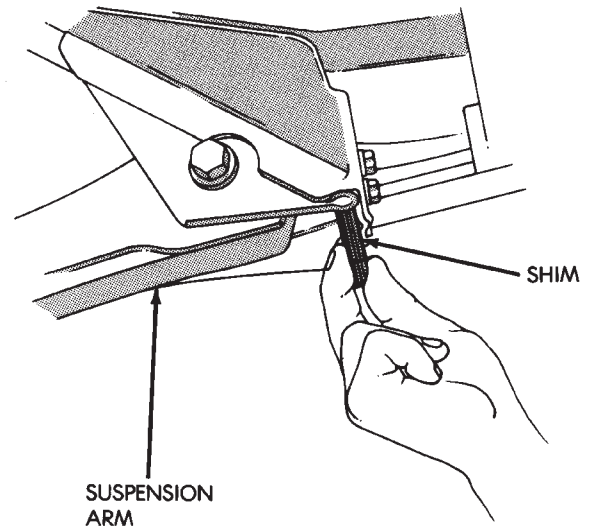

J8916-22

**Fig. 10 Angle Adjustment—XJ Vehicles**

## SERVICE PROCEDURES

## PRECAUTIONS

Use exact replacement hardware for attaching the propeller shafts. Exact replacement will ensure safe operation. The specified torque must always be applied when tightening the fasteners.

Put reference marks on the propshaft yoke and axle or transmission yoke before service (Fig. 1). This will assure correct phasing and eliminate possible vibration.

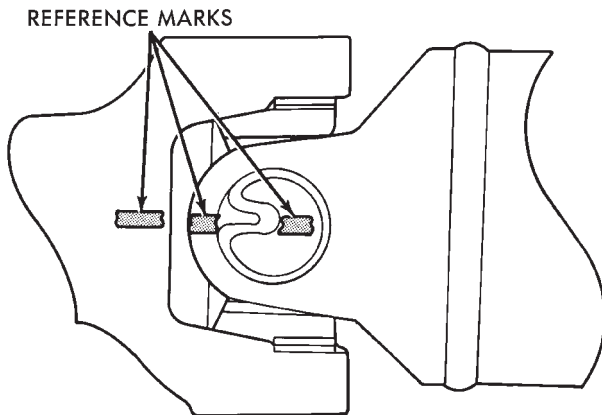

J9316-2

*Fig. 1 Reference Marks on Yokes*

**CAUTION:** Do not allow the propeller shaft to drop or hang from either universal joint during removal. Attach it to the vehicle underside with wire to prevent damage to the universal joints.

**CAUTION:** It is very important to protect the machined, external surface of the slip yoke from damage after propeller shaft removal. If damaged, the transmission extension seal could be damaged and cause a leak.

## FRONT—XJ VEHICLES

## REMOVAL

- (1) Raise the vehicle.
- (2) Scribe alignment marks on the yokes at the transfer case. Place marks at the pinion shaft and at each end of the propeller shaft. These marks will be used for installation reference (Fig. 2).
- (3) Remove the U-joint strap bolts at the pinion shaft yoke.
- (4) Disconnect the propeller shaft at the transfer case and remove the propeller shaft.

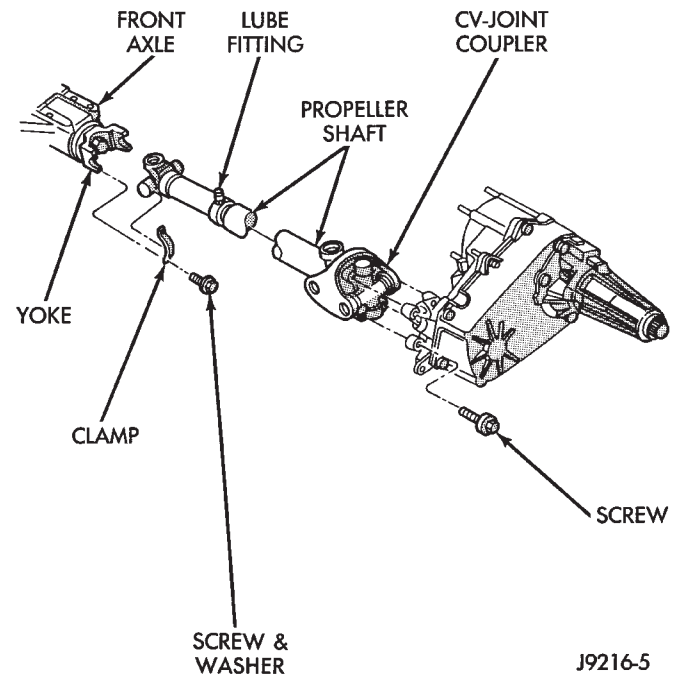

J9216-5

*Fig. 2 Front Propeller Shaft*

## INSTALLATION

(1) Position the propeller shaft with the yoke reference marks aligned (Fig. 1). Install the propeller shaft.

**Replacement U-joint straps and bolts must be installed.**

- (2) Tighten the U-joint strap/clamp bolts at the axle yoke to 19 N·m (14 ft. lbs.) torque.
- (3) Tighten the flange to transfer case bolts to 27 N·m (20 ft. lbs.) torque.
- (4) Lower the vehicle.

## REAR—XJ, YJ VEHICLES

## REMOVAL

- (1) Shift the transmission and transfer case (if applicable) to their Neutral positions. Raise the vehicle.
- (2) Scribe alignment marks at the pinion shaft and at each end of the propeller shaft. These marks will be used for installation reference.
- (3) Remove the U-joint strap bolts at the pinion shaft yoke.
- (4) Slide the slip yoke off of the transmission/transfer case output shaft and remove the propeller shaft (Fig. 3).

## INSTALLATION

(1) Slide the slip yoke on the transmission/transfer case output shaft. Align the installation reference marks at the axle yoke and install the propeller shaft (Fig. 3).



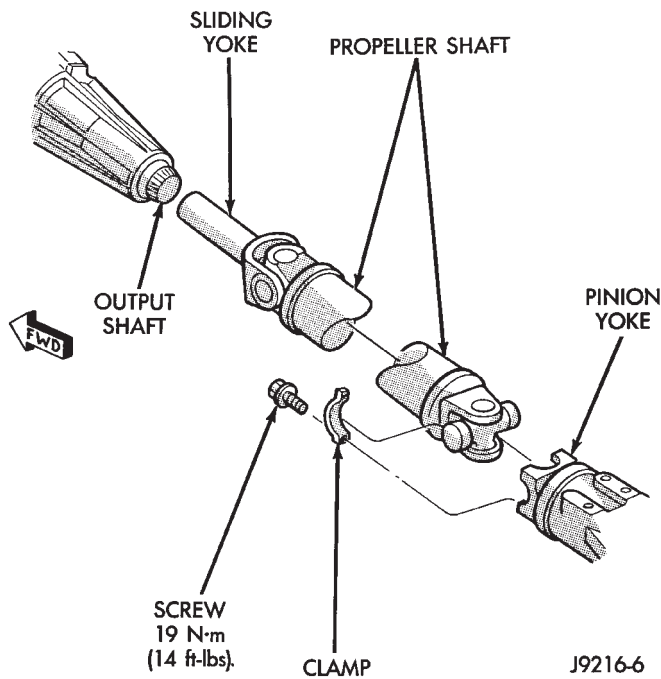

**Fig. 3 Rear Propeller Shaft**

**Replacement U-joint straps and bolts must be installed.**

- (2) Tighten the U-joint strap/clamp bolts at the axle yoke to 19 N·m (14 ft. lbs.) torque.
- (3) Lower the vehicle.

#### FRONT—YJ VEHICLES

##### REMOVAL

- (1) Raise the vehicle.
- (2) Scribe alignment marks on the yokes at the transfer case. Place marks at the pinion shaft and at

each end of the propeller shaft. These marks will be used for installation reference (Fig. 4).

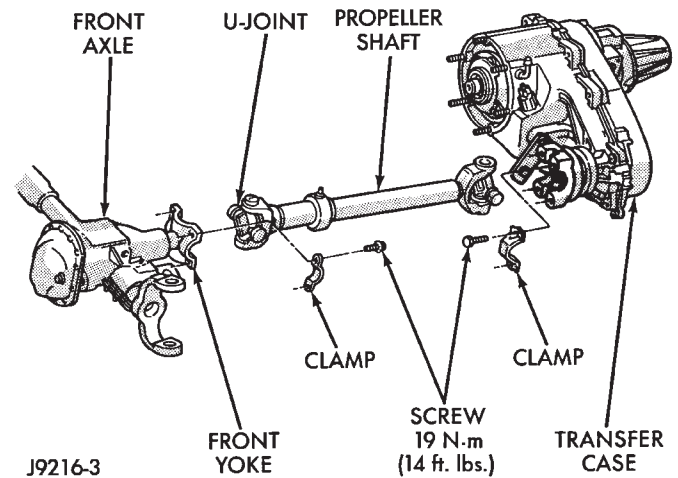

**Fig. 4 YJ Front Propeller Shaft**

- (3) Remove the U-joint strap bolts at the pinion shaft yoke.
- (4) Disconnect the propeller shaft at the transfer case and remove the propeller shaft.

##### INSTALLATION

- (1) Position the propeller shaft with the reference marks aligned (Fig. 4). Install the propeller shaft.
- Replacement U-joint straps and bolts must be installed.**
- (2) Tighten the U-joint strap/clamp bolts at the axle yoke to 19 N·m (14 ft. lbs.) torque.
- (3) Tighten the U-joint strap/clamp to transfer case bolts to 27 N·m (20 ft. lbs.) torque.
- (4) Tighten the U-joint strap bolts to 19 N·m (14 ft. lbs.) torque.
- (5) Lower the vehicle.

## UNIVERSAL JOINT REPLACEMENT

## PRECAUTIONS

It is very important to put reference marks on the yokes before removal or component service (Fig. 1). This will assure correct phasing and eliminate possible vibration.

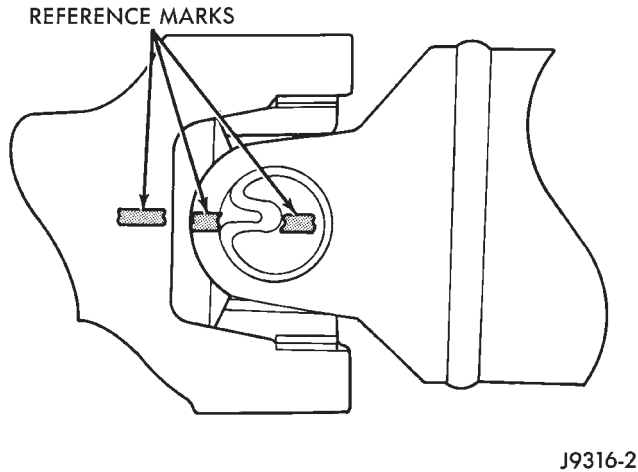

Fig. 1 Reference Marks on Yokes

## SINGLE CARDAN

## REMOVAL/DISASSEMBLY

Single cardan universal joints are not serviceable. If worn or leaking, they must be replaced as a unit.

(1) Remove the propeller shaft. Refer to Propeller Shaft Replacement in this Group.

(2) **Paint or score alignment marks on the yokes and propeller shaft for installation reference.**

(3) Using a soft drift, tap the outside of the bearing assembly to loosen snap ring.

(4) Remove snap rings from both sides of yoke (Fig. 2).

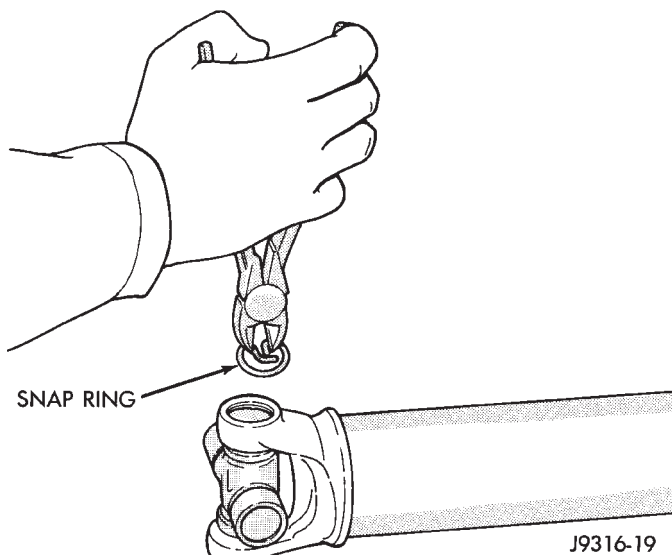

Fig. 2 Remove Snap Ring

(5) Set the yoke in an arbor press or vise with a large socket beneath it. Position the yoke with the lube fitting pointing up (if equipped). Place a smaller socket on the upper bearing assembly and press it through to release the lower bearing assembly (Fig. 3).

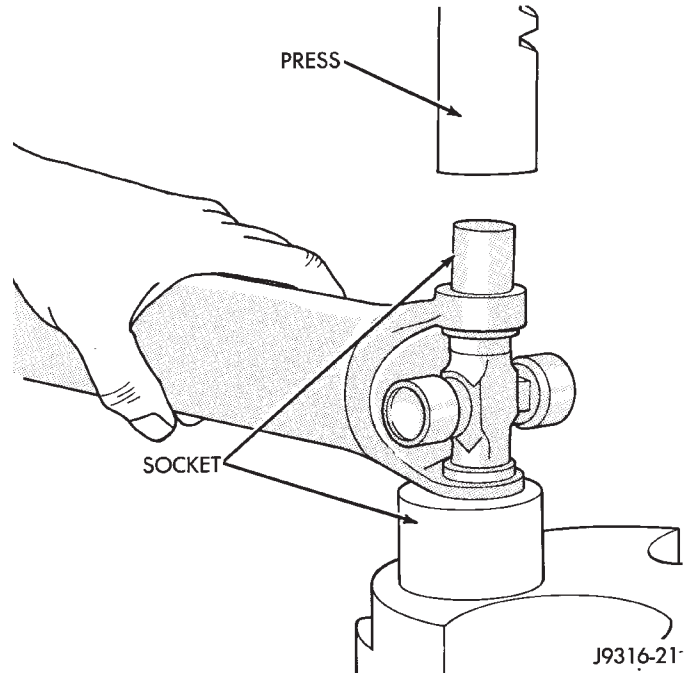

Fig. 3 Press Out Bearing

(6) If the bearing assembly will not pull out by hand after pressing, tap the base of the lug near it to dislodge.

(7) To remove the opposite bearing, turn the yoke over and straighten the cross in the open hole. Then carefully press the end of the cross until the remaining bearing can be removed (Fig. 4).

**CAUTION:** If the cross or bearing assembly are cocked when being pressed, the bearing assembly will score the walls of the yoke bore and ruin the yoke.

## CLEANING AND INSPECTION

(1) Clean all the universal joint yoke bores with cleaning solvent and a wire brush.

(2) Inspect the yokes for distortion, cracks and worn bearing assembly bores.

## ASSEMBLY/INSTALLATION

(1) Apply extreme pressure (EP) N.L.G.I. Grade 1 or 2 grease to aid in installation.

(2) Position the cross in the yoke with its lube fitting (if equipped) pointing up (Fig. 5).

(3) Place a bearing assembly over the trunnion and align it with the cross hole (Fig. 6). Keep the needle

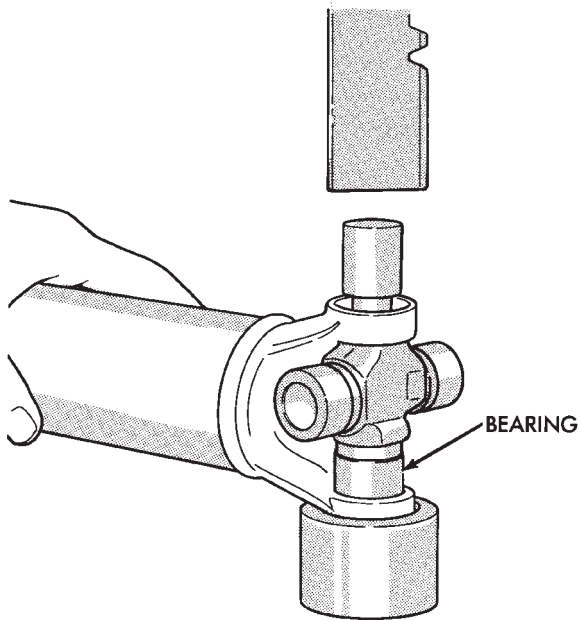

J9316-24

**Fig. 4 Press Out Remaining Bearing**

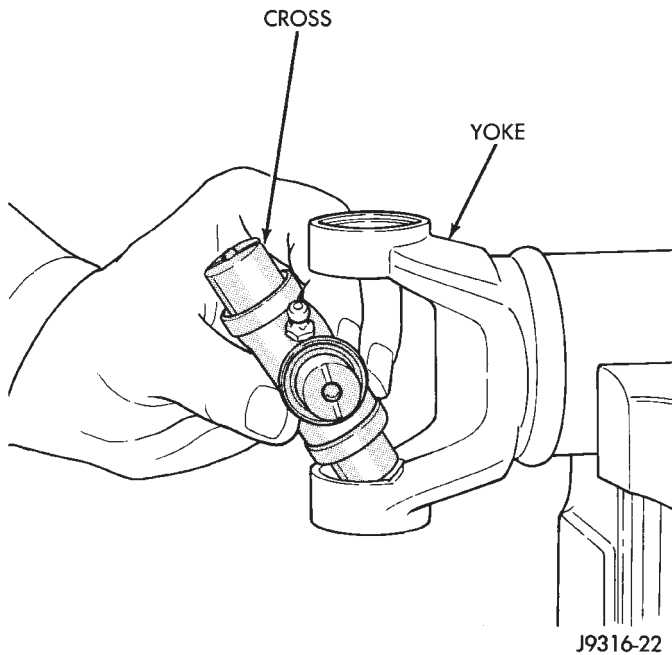

J9316-22

**Fig. 5 Install Cross In Yoke**

bearings upright in the bearing assembly. A needle roller lying at the bottom will prevent proper assembly.

(4) Press the bearing assembly into the cross hole enough to install a snap ring. Install a snap ring.

(5) Repeat steps 3 and 4 to install the opposite bearing assembly. If the joint is stiff, strike the yoke with a soft hammer to seat the needle bearings. Install a snap ring.

(6) Add grease to lube fitting (if equipped).

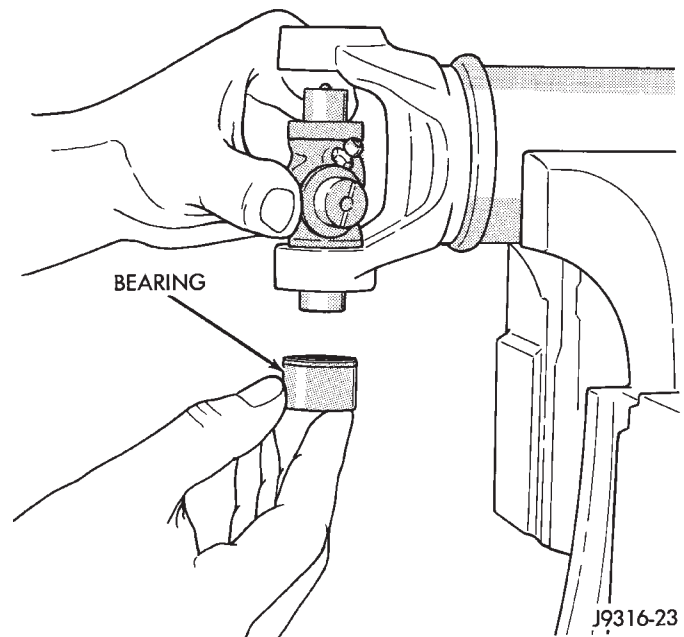

J9316-23

**Fig. 6 Install Bearing On Trunnion**

(7) Install the propeller shaft. Refer to Propeller Shaft Replacement in this Group.

## DOUBLE CARDAN (CV)

### REMOVAL/DISASSEMBLY

Cardan universal joints are not serviceable. If worn or leaking, they must be replaced as a unit.

(1) Remove the propeller shaft. Refer to Propeller Shaft Replacement in this Group.

(2) **Paint or score alignment marks on the yokes and propeller shaft for installation reference.**

(3) Remove all the bearing assembly snap rings (Fig. 7).

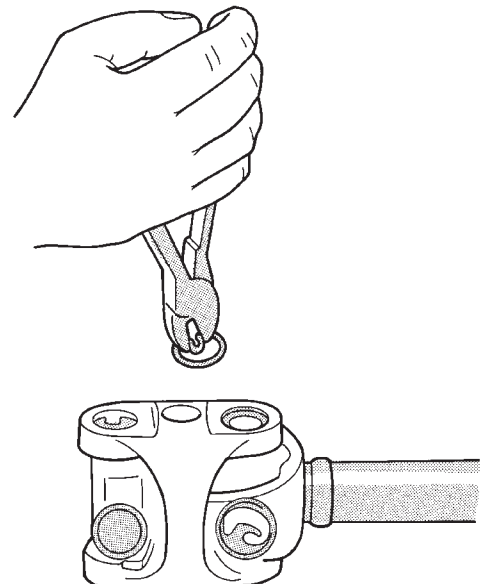

J9316-5

**Fig. 7 Remove Snap Rings**

(4) Press the bearing assembly partially from the outboard side of the center yoke, enough to grasp by vise jaws (Fig. 8). Be sure to remove any lube fittings that may interfere with removal.

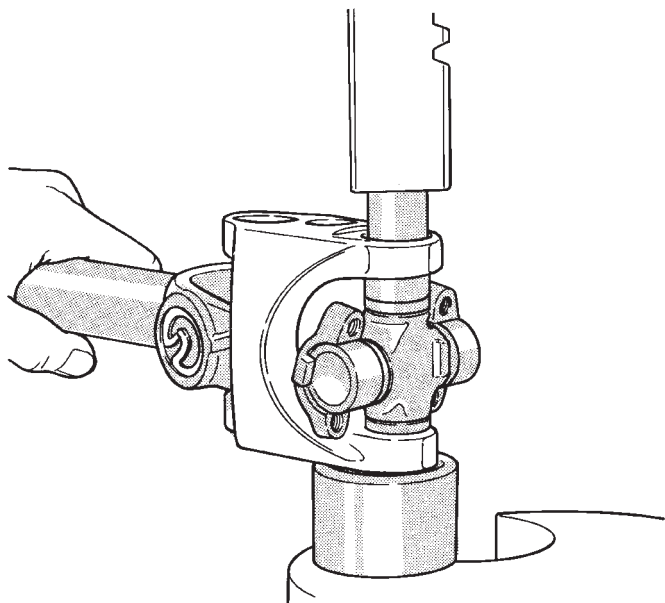

J9316-6

**Fig. 8 Press Out Bearing**

(5) Grasp the protruding bearing by vise jaws. Tap the tube yoke with a mallet and drift to dislodge from the yoke (Fig. 9).

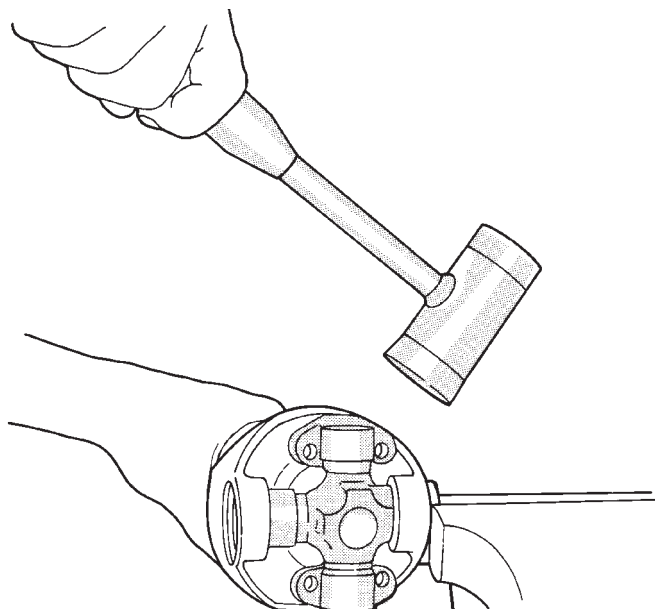

J9316-7

**Fig. 9 Remove Bearing From Yoke**

(6) Flip assembly and repeat steps 4 and 5 for removing the opposite side bearing. This will then allow removal of the cross centering kit assembly and spring (Fig. 10).

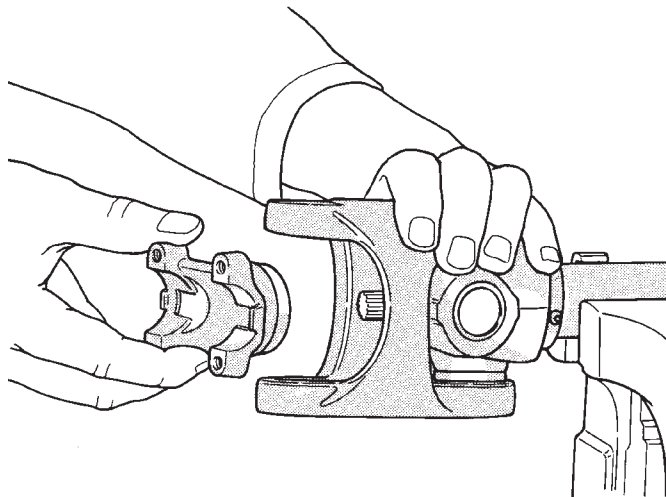

J9316-8

**Fig. 10 Remove Centering Kit**

(7) Press the remaining bearing assemblies out the other cross as described above to complete the disassembly.

#### CLEANING AND INSPECTION

(1) Clean all the U-joint yoke bores with cleaning solvent and a wire brush.

(2) Inspect the yokes for distortion, cracks and worn bearing assembly bores.

#### ASSEMBLY/INSTALLATION

**During installation, ensure that the spiders and yokes are aligned to the reference marks.**

(1) Fit a cross into the tube yoke (Fig. 11).

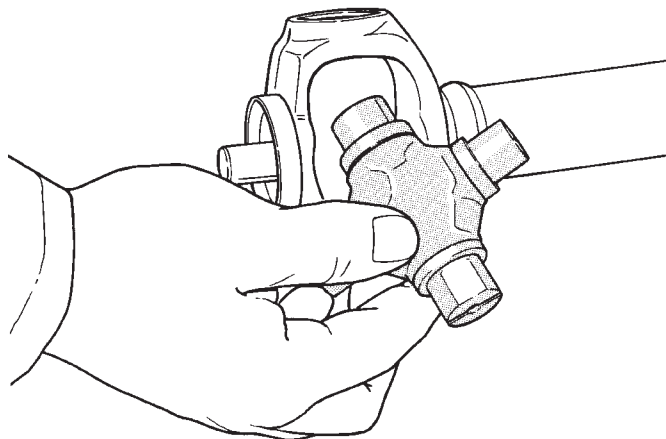

J9316-9

**Fig. 11 Install Cross In Yoke**

(2) Place a bearing assembly in a tube yoke hole and over a trunnion. Keep the needle bearings upright in the bearing assembly (Fig. 12). A needle roller lying at the bottom will prevent proper assembly. Be sure to remove any lube fittings that may interfere with removal.

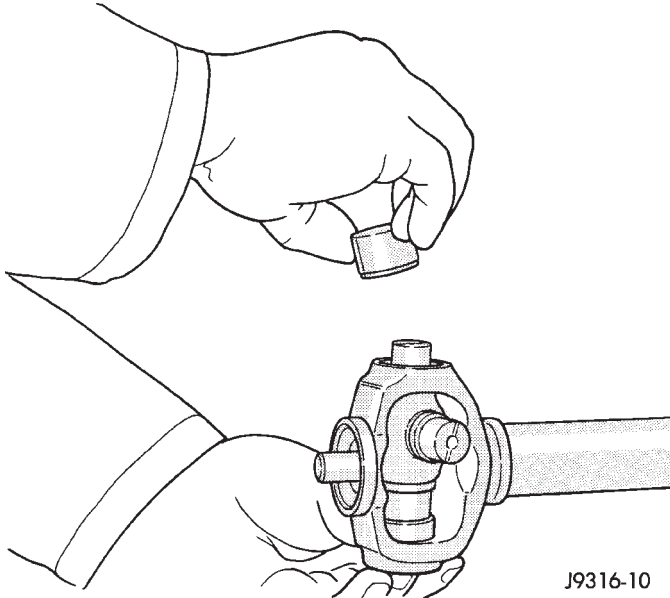

J9316-10

**Fig. 12 Install Bearing Assembly**

(3) Press the bearing assembly in place and install a snap ring (Fig. 13).

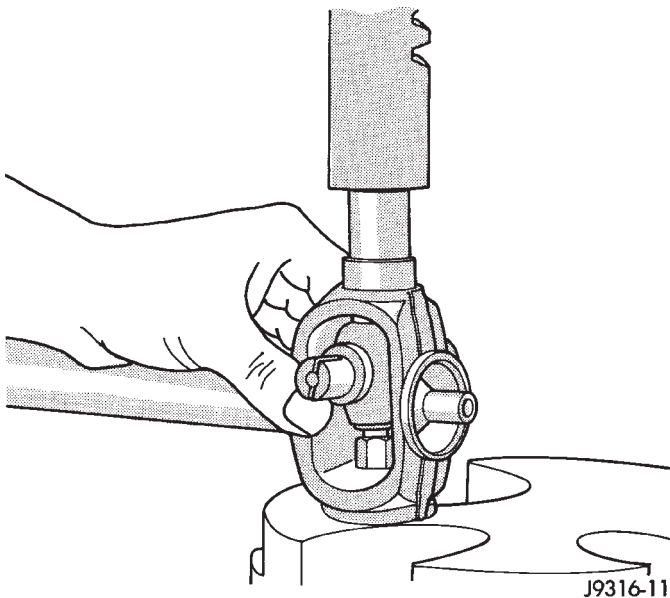

J9316-11

**Fig. 13 Press In Bearing Assembly**

(4) Flip the tube yoke and bearing assembly installation on the opposite trunnion. Install a snap ring (Fig. 14).

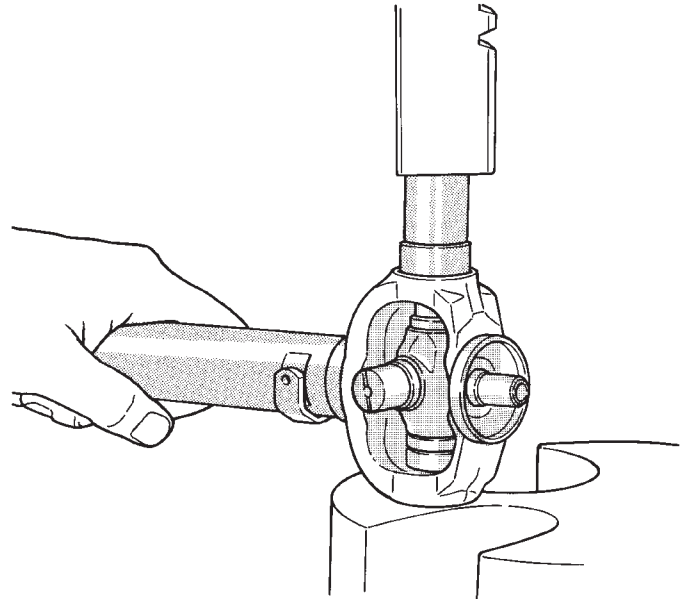

J9316-12

**Fig. 14 Press In Bearing Assembly**

(5) Fit the center yoke on the remaining two trunnions and press bearing assemblies in place, both sides (Fig. 15). Install a snap ring.

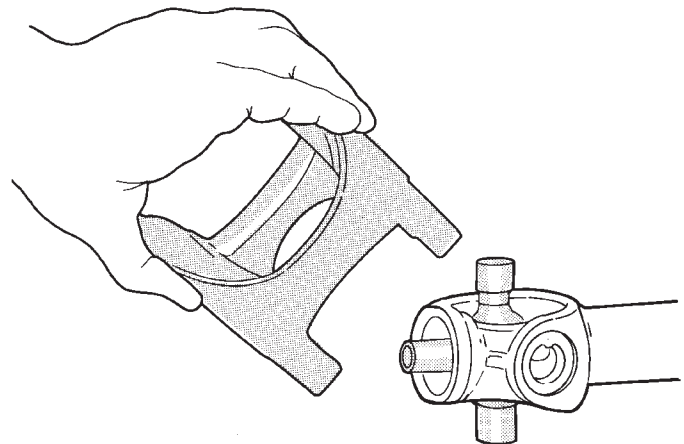

J9316-13

**Fig. 15 Install Center Yoke**



(6) Install the centering kit assembly inside the center yoke making sure the spring is in place (Fig. 16).

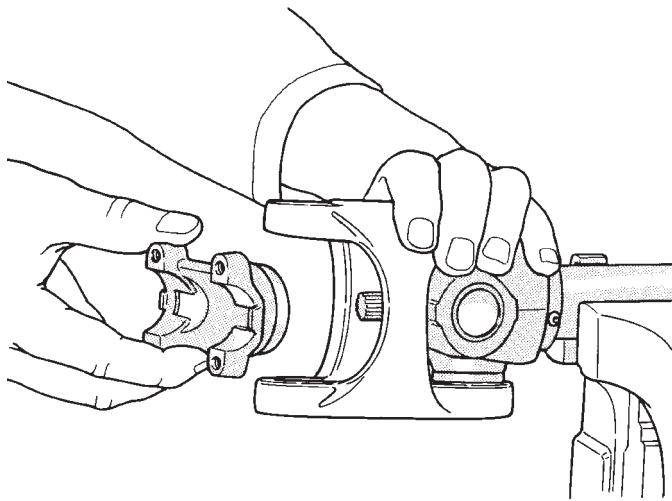

J9316-14

**Fig. 16 Install Centering Kit**

(7) Place two bearing assemblies on the remaining cross (opposite sides). Fit the open trunnions into the center yoke holes and the bearing assemblies into the centering kit (Fig. 17).

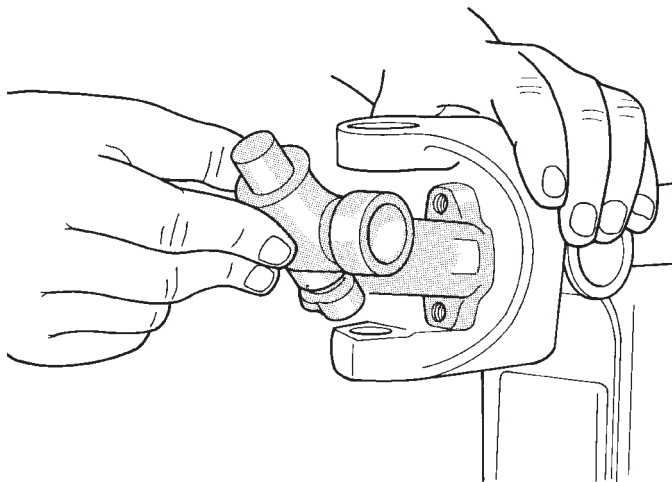

J9316-15

**Fig. 17 Install Remaining Cross**

(8) Press the remaining two bearing assemblies into place and install snap rings (Fig. 18).

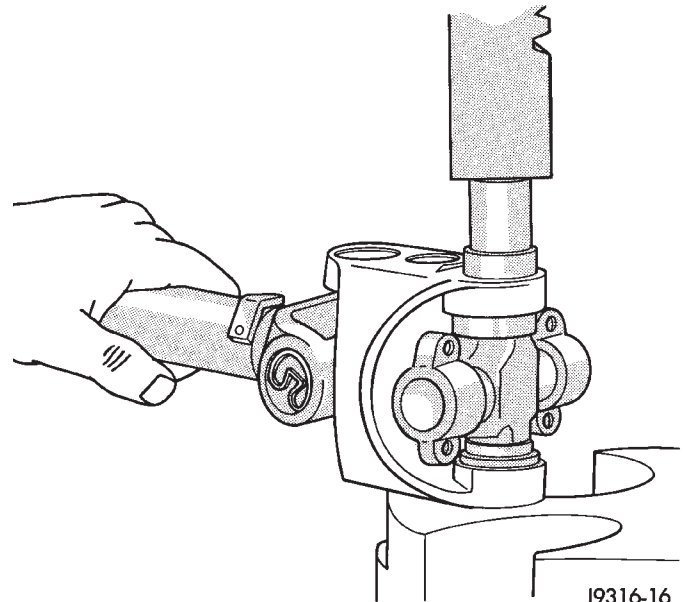

J9316-16

**Fig. 18 Press In Bearing Assembly**

(9) Tap the snap rings to allow them to seat into the grooves (Fig. 19).

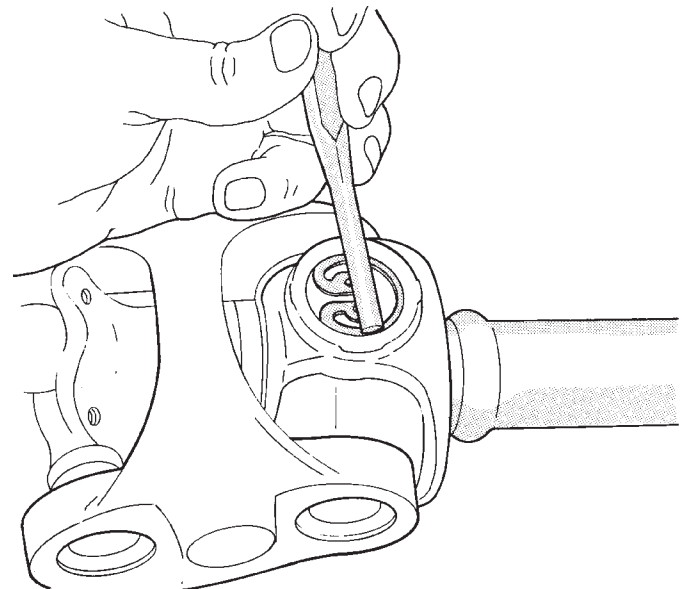

J9316-17

**Fig. 19 Seat Snap Rings In Groove**

(10) Check for proper assembly. Flex the CV joint beyond center, it should snap over-center in both directions when correctly assembled (Fig. 20).

(11) Install the propeller shaft. Refer to Propeller Shaft Replacement in this Group.

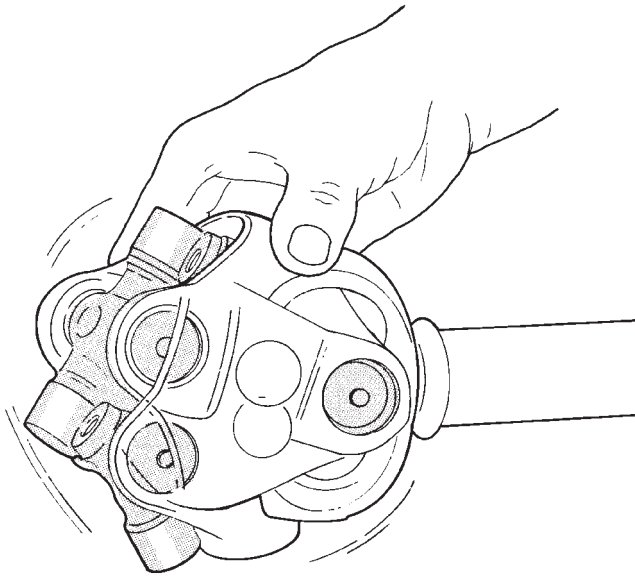

J9316-18

**Fig. 20 Check Assembly**

TORQUE SPECIFICATIONS

**PROPELLER SHAFTS AND U-JOINTS**

DESCRIPTION .....	TORQUE
<b>Front Shaft</b>	
Transfer Case Yoke Bolts .....	27 N·m (20 ft. lbs.)

Axle Yoke Bolts .....	19 N·m (14 ft. lbs.)
<b>Rear Shaft</b>	
Axle Yoke Bolts .....	19 N·m (14 ft. lbs.)

