

STEERING

CONTENTS

	page		page
GENERAL INFORMATION	1	STEERING COLUMN GENERAL SERVICE—XJ .	47
GENERAL INFORMATION	48	STEERING COLUMN—YJ	58
MANUAL STEERING GEAR	37	STEERING LINKAGE—XJ	16
POWER STEERING PUMP	11	STEERING LINKAGE—YJ	19
POWER STEERING SYSTEM DIAGNOSIS	3	STEERING RHD	74
RECIRCULATING BALL POWER STEERING GEAR	21	TORQUE SPECIFICATIONS	78

GENERAL INFORMATION

STEERING SYSTEM COMPONENTS

Jeep vehicles can have either a manual or power steering system (Fig. 1). A recirculating-ball type steering gear is used for both systems.

Power steering systems use;

- Steering gear
- Pressure and return fluid hoses and fittings
- Belt driven steering pump
- Integral or remote body mounted pump reservoir

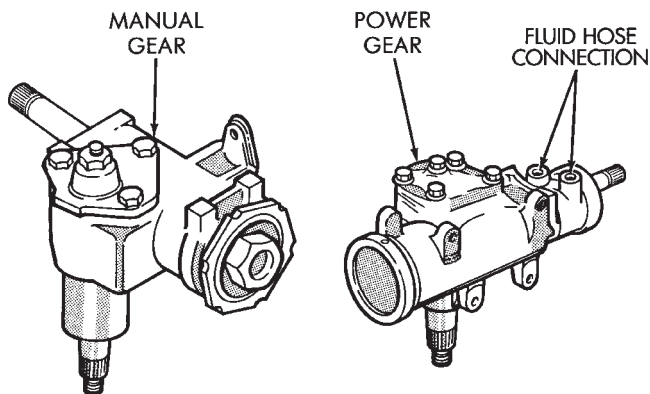

J9219-20

Fig. 1 Steering Gears

POWER STEERING GEAR

The steering gear is mounted on the left frame rail. The gear is joined to the intermediate shaft by a universal joint coupling. The coupling helps isolate noise and road shock from the interior.

The major internal components of the gear are the:

- Rotary valve assembly
- Steering worm shaft
- Rack piston assembly
- Pitman shaft

The movement of these parts, while turning or parking, is aided by hydraulic pressure and flow supplied by the pump. Manual steering is always available at times when the engine is not running or in the event of pump or belt failure. Steering effort is higher under such conditions.

The steering stub shaft, rotary valve, worm shaft, and rack piston assembly are all in line. The oil passages are internal within the gear housing except for pressure and return hoses between the gear and pump.

The power steering gear has a recirculating ball system. This acts as a rolling thread between the worm shaft and rack piston. The worm shaft is supported by a thrust bearing at the lower end and a bearing assembly at the upper end. When the worm shaft is turned right, the rack piston moves up in gear. Turning the worm shaft left moves the rack piston down in gear. The rack piston teeth mesh with the sector, which is part of the pitman shaft. Turning the worm shaft turns the pitman shaft, which turns the wheels through the steering linkage.

The control valve in the steering gear directs the power steering fluid to either side of the rack piston. The rack piston is assisted by hydraulic pressure. If the steering system loses hydraulic pressure, the vehicle can be controlled manually, but with higher steering effort.

An identification code located on the side cover designates the gear ratio (Fig. 2).

- Code BH designates 14:1 ratio used in XJ vehicles
- Code BF designates 13-16:1 ratio used in YJ vehicles

A recirculating-ball steering gear is used with the power (assisted) steering system (Fig. 1). The power steering gear can be adjusted and internally serviced.

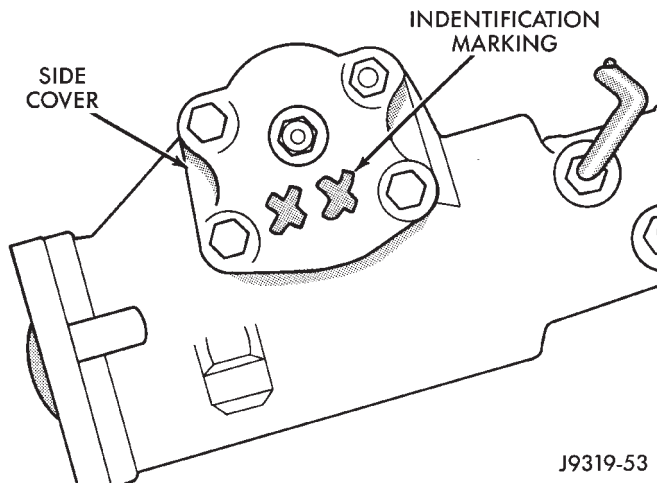

Fig. 2 Ratio Code Location

POWER STEERING PUMP

Hydraulic pressure is provided for operation of the power steering gear by a belt driven power steering pump. The power steering pump is a constant flow rate and displacement, vane-type pump. The internal parts in the housing operate submerged in fluid. The flow control orifice is part of the high pressure line fitting. The pressure relief valve inside the flow control valve limits the pump pressure.

Power steering pumps have different pressure rates and are not interchangeable with other pumps.

The power steering pump is connected to the steering gear via high pressure and return hose. The pump shaft has a pressed-on drive pulley that is belt driven by the crankshaft pulley (Fig. 3).

XJ vehicles with 2.5L engines and all YJ vehicles: The reservoir is mounted at the front left side of the engine compartment. XJ vehicles equipped with a 4.0L engine have the reservoir attached to the pump body with spring clips.

STEERING COLUMNS

Two general types of steering columns are installed on Jeep vehicles: a fixed, non-tilt column and a tilt column (Fig. 4).

The ignition key/lock cylinder is located in the steering column. When the key/lock cylinder is turned to the LOCK position, the ignition switch and steering shaft cannot be operated. For vehicles with

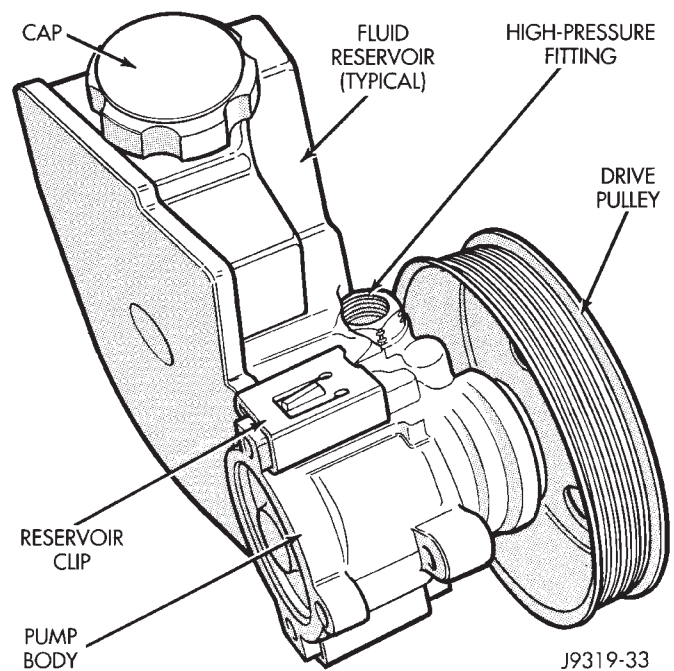
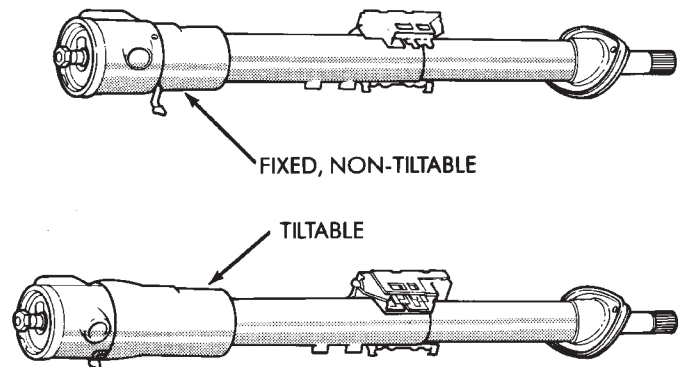

Fig. 3 TC Series Pump With Integral Reservoir

an automatic transmission, the lock mechanism also prevents operation of the gear shift mechanism.



J8919-7

Fig. 4 Steering Columns

The center, slip-type intermediate shaft is attached to the steering gear and steering column shaft with universal joints.

Both types of steering columns have anti-theft provisions. They are energy-absorbing.

POWER STEERING SYSTEM DIAGNOSIS

PUMP PRESSURE TEST

- (1) Check belt tension and adjust as necessary.
- (2) Disconnect high pressure hose at gear or pump. Use a container for dripping fluid.
- (3) Connect Gauge 7617 to both hoses using adapter fitting (Fig. 1). Connect spare pressure hose to gear or pump.

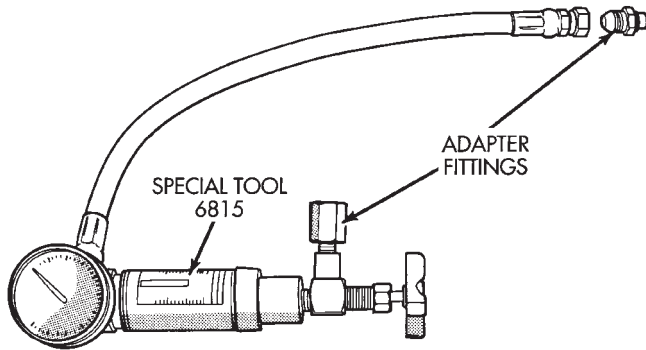

Fig. 1 Pressure Test Gauge

- (4) Open the test valve completely.
- (5) Start engine and let idle.
- (6) Check fluid level, add fluid as necessary.
- (7) Gauge should read below 862 kPa (125 psi), if above, inspect the hoses for restrictions and repair as necessary. The initial pressure should be in the range of 345-552 kPa (50-80 psi).

CAUTION: The following test procedure involves testing maximum pump pressure output and flow control valve operation. Do not leave valve closed for more than 5 seconds as the pump could be damaged.

(8) Close valve fully three times and record highest pressure indicated each time. **All three readings must be above specifications and within 345 kPa (50 psi) of each other.**

- Pressures above specifications but not within 345 kPa (50 psi) of each other, replace pump.
- Pressures within 345 kPa (50 psi) of each other but below specifications, replace pump.

CAUTION: Do not force the pump to operate against the stops for more than 2 to 4 seconds at a time. Pump damage will result.

(9) Open the test valve, turn steering wheel extreme left and right positions against the stops. Record the highest indicated pressure at each position. Compare readings to specifications. If highest output pressures are not the same against either stop, the gear is leaking internally and must be repaired.

PUMP OPERATING SPECIFICATIONS

VEHICLE	RELIEF PRESSURE (P.S.I.) \pm 50
YJ	1050
XJ	1400

J9319-89

POWER STEERING SYSTEM DIAGNOSIS

STEERING NOISES

There is some noise in all power steering systems. One of the most common is a hissing sound evident at standstill parking. Hiss is a high frequency noise similar to that experienced while slowly closing a water tap. The noise is present in every valve and results from high velocity fluid passing valve orifice edges. There is no relationship between this noise and performance of the steering. Hiss may be expected when steering wheel is at end of travel or when slowly turning at standstill.

CONDITION	POSSIBLE CAUSES	CORRECTION
OBJECTIONAL HISS OR WHISTLE	<ol style="list-style-type: none"> 1. Damaged or mispositioned steering column coupler to dash panel seal. 2. Noisy valve in power steering gear. 	<ol style="list-style-type: none"> 1. Check for proper seal between steering column coupler and dash seal. 2. Replace steering gear.
RATTLE OR CLUNK	<ol style="list-style-type: none"> 1. Gear loose on front crossmember. 2. Crossmember-to-frame bolts or studs loose. 3. Tie rod looseness (outer or inner). 4. Loose lower control arm to crossmember bolts. 5. Loose strut to body attaching bolts. 6. Pressure hose touching other parts of body. 7. Noise internal to gear. 8. Damaged front crossmember. 	<ol style="list-style-type: none"> 1. Check gear-to-crossmember mounting bolts. Tighten to specification. 2. Torque bolts and studs to specifications. 3. Check tie rod pivot points for wear. Replace if necessary. 4. Torque control arm bolts to specifications. 5. Check upper strut mount to body attaching bolts to see if torqued to specifications. 6. Adjust hose to proper position by loosening, repositioning and tightening fitting. Do not bend tubing. 7. Replace gear. 8. Replace front crossmember.
CHIRP OR SQUEAL (IN THE AREA OF PUMP) PARTICULARLY NOTICEABLE AT FULL WHEEL TRAVEL AND DURING STANDSTILL PARKING	<ol style="list-style-type: none"> 1. Loose belt. 	<ol style="list-style-type: none"> 1. Adjust belt tension to specification.

POWER STEERING SYSTEM DIAGNOSIS

STEERING NOISES – Continued		
There is some noise in all power steering systems. One of the most common is a hissing sound evident at standstill parking. Hiss is a high frequency noise similar to that experienced while slowly closing a water tap. The noise is present in every valve and results from high velocity fluid passing valve orifice edges. There is no relationship between this noise and performance of the steering. Hiss may be expected when steering wheel is at end of travel or when slowly turning at standstill.		
CONDITION	POSSIBLE CAUSES	CORRECTION
Pump growl results from the development of high pressure fluid flow. Normally this noise should not be high enough to be objectionable. Abnormal situations, such as a low oil level causing aeration or hoses touching the vehicle body, can create a noise level that could bring complaints.		
WHINE OR GROWL (PUMP NOISE)	<ol style="list-style-type: none"> 1. Low fluid level. 2. Hose touching vehicle body or frame. 3. Extreme wear of pump internal parts. 	<ol style="list-style-type: none"> 1. Fill to proper level and perform leakage diagnosis. (Recheck after system is free of aeration.) 2. Reposition hose. Replace hose if tube ends are bent. 3. Replace pump and flush system.
SUCKING AIR SOUND	<ol style="list-style-type: none"> 1. Loose return line clamp. 2. Missing O-ring on hose connection. 3. Low fluid level. 4. Air leak between reservoir and pump. 	<ol style="list-style-type: none"> 1. Tighten or replace clamp. 2. Inspect connection and replace O-ring as required. 3. Fill to proper level and perform leakage diagnosis. 4. Inspect and replace reservoir as required.
SQUEAK OR RUB SOUND	<ol style="list-style-type: none"> 1. Sound from steering column. 2. Sound internal to steering gear. 	<ol style="list-style-type: none"> 1. Check for squeak in steering column. Inspect for contact between shroud intermediate shaft, column, and wheel. (Realign if necessary.) (a) Check for lack of grease on steering column, dash to lower coupling seal. 2. Replace gear.
SCRUBBING/KNOCKING	<ol style="list-style-type: none"> 1. Incorrect tire size. 2. Check clearance between tires and other vehicle components, through full travel. 3. Check for interference between steering gear and other components. 4. Incorrect gear supplied. 	<ol style="list-style-type: none"> 1. Verify tire size is the same as originally supplied. 2. Correct as necessary. 3. Correct as necessary. 4. Replace gear.

POWER STEERING SYSTEM DIAGNOSIS

BINDS/STICKS/SEIZED

CONDITION	POSSIBLE CAUSES	CORRECTION
CATCHES, STICKS IN CERTAIN POSITIONS OR DIFFICULT TO TURN	<ol style="list-style-type: none"> 1. Low fluid level. 2. Tires not properly inflated. 3. Lack of lube in ball joints. 4. Lack of lube in outer tie rod ends. 5. Loose pump belt. 6. Faulty pump flow control (Verify cause using Pump Test Procedure). 7. Excessive friction in steering column or intermediate shaft. 8. Steering column coupling binding. 9. Binding upper strut bearing. 10. Excessive friction in steering gear. 	<ol style="list-style-type: none"> 1. Fill to proper level and perform leakage diagnosis. 2. Inflate tires to proper pressure. 3. Lubricate where possible. 4. Lubricate where possible. 5. Tighten or replace belt. 6. Replace pump. 7. Correct condition. (See Steering Column Service Procedure.) 8. Realign as necessary. 9. Correct binding condition. 10. Replace steering gear.

SHAKE/SHUDDER/VIBRATION

CONDITION	POSSIBLE CAUSES	CORRECTION
VIBRATION OF THE STEERING WHEEL AND/OR DASH DURING DRY PARK OR LOW SPEED STEERING MANEUVERS	<ol style="list-style-type: none"> 1. Air in the power steering system. 2. Tires not properly inflated. 3. Excessive engine vibration. 4. Loose tie rod end. 5. Overcharged air conditioning system. 	<ol style="list-style-type: none"> 1. Steering shudder can be expected in new vehicles and vehicles with recent steering system repairs. Shudder should improve after the vehicle has been driven several weeks. 2. Inflate tires to proper pressure. 3. Make sure that engine is running properly. 4. Check inner and outer tie rod and jam nut for excessive free play. 5. Check air conditioning pump head pressure. (See Air Conditioning Refrigerant System Diagnosis).

POWER STEERING SYSTEM DIAGNOSIS

LOW ASSIST, NO ASSIST, OR HARD STEERING

CONDITION	POSSIBLE CAUSES	CORRECTION
STIFF, HARD TO TURN, SURGES, MOMENTARY INCREASE IN EFFORT WHEN TURNING	<ol style="list-style-type: none"> 1. Tires not properly inflated. 2. Low fluid level. 3. Loose belt. 4. Lack of ball joint lubrication. 5. Low pressure pump (Verify using Pump Test Procedure). 6. High internal leak gear. 	<ol style="list-style-type: none"> 1. Inflate tires to proper pressure. 2. Add power steering fluid as required and perform leakage diagnosis. 3. Tighten or replace belt. 4. Lubricate or replace as required. 5. Verify cause using Pump Test Procedure. Replace pump if necessary. 6. Check steering system using test procedure. If steering gear is at fault, replace steering gear.

POOR RETURN TO CENTER

CONDITION	POSSIBLE CAUSES	CORRECTION
STEERING WHEEL DOES NOT WANT TO RETURN TO CENTER POSITION	<ol style="list-style-type: none"> 1. Tires not properly inflated. 2. Improper front wheel alignment. 3. Lack of lubrication in ball joint. 4. Steering column U-joints misaligned. 5. Mispositioned dash cover. 6. Steering wheel rubbing. 7. Damaged, mis-positioned or un-lubricated steering column coupler to dash seal. 8. Binding upper strut bearing. 9. Tight steering shaft bearing. 10. Excessive friction in steering coupler. 11. High friction in steering gear. 	<ol style="list-style-type: none"> 1. Inflate tires to proper pressure. 2. Check and adjust as necessary. 3. Replace as required or lubricate. 4. Realign steering column U-joints. 5. Reposition dash cover. To evaluate items 6 and 7, disconnect the intermediate steering shaft. Turn the steering wheel and listen for internal rubbing in column. 6. Adjust covers. 7. Correct condition. 8. Repair binding condition. 9. Replace steering column. 10. Replace steering coupler. 11. Replace steering gear.

POWER STEERING SYSTEM DIAGNOSIS

LOOSE STEERING

CONDITION	POSSIBLE CAUSES	CORRECTION
EXCESSIVE WHEEL KICKBACK OR TOO MUCH STEERING WHEEL PLAY	<ol style="list-style-type: none"> 1. Air in system. 2. Gear loose on crossmember. 3. Free play in steering column. 4. Loose ball joints. 5. Pinch bolt loose on ball joint. 6. Front wheel bearings loose or worn. 7. Loose outer tie rod ends. 8. Loose inner tie rod ends. 9. Defective steering gear rotary valve. 	<ol style="list-style-type: none"> 1. Add fluid. 2. Check gear to crossmember mounting bolts. Tighten to specification. 3. Check and replace as required. 4. Check and replace as required. 5. Check pinch bolts and tighten as required to specified torque. 6. Tighten hub nut or replace with new parts as necessary. 7. Check and replace as required. 8. Replace gear. 9. Replace gear.

VEHICLE LEADS TO THE SIDE

CONDITION	POSSIBLE CAUSES	CORRECTION
WHEEL DOES NOT WANT TO RETURN TO CENTER POSITION	<ol style="list-style-type: none"> 1. Radial tire lead. 2. Front end misaligned. 3. Wheel braking. 4. Unbalanced steering gear valve. (If this is the cause, the steering efforts will be very light in direction of lead and heavier in the opposite direction). 	<ol style="list-style-type: none"> 1. Rotate tires as recommended in Tire Service. 2. Align front end as recommended in Wheel Alignment Service Procedure. 3. Check for dragging brakes as directed in Brake Service Procedure. 4. Replace steering gear.
STEERING WHEEL HAS FORE-AFT LOOSENESS	<ol style="list-style-type: none"> 1. Steering wheel to steering column shaft nut not securely tightened. 2. Steering column lower bearing spring retainer slipped on steering column shaft. 	<ol style="list-style-type: none"> 1. Torque not to proper torque specification. 2. Replace steering column.

POWER STEERING SYSTEM DIAGNOSIS

FLUID LEAK

CONDITION	POSSIBLE CAUSES	CORRECTION
LOW FLUID LEVEL WITH: • NO VISIBLE SIGNS OF LEAKS ON THE STEERING GEAR, PUMP, ON FLOOR, OR ANYWHERE ELSE LOW FLUID LEVEL WITH: • VISIBLE LEAK ON STEERING GEAR, PUMP, FLOOR, OR ANYWHERE ELSE	1. Overfilled reservoir. 2. Hose connections at pump or gear. 3. Pump or gear leak.	1. Adjust fill level. 2. Check for loose fittings and tighten to specifications. If fittings are tight, examine for damaged or missing O-ring and replace as required. 3. Identify location of leak and repair or replace as indicated in Power Steering Pump and/or Gear sections of this service manual.

FOAMY OR MILKY FLUID

CONDITION	POSSIBLE CAUSES	CORRECTION
AERATION AND OVER-FLOW OF FLUID	1. Air leaks. 2. Low fluid level. 3. Cracked pump housing. 4. Water contamination.	1. Check for air leak as described under sucking air and correct. 2. Extremely cold temperatures may cause system aeration if the oil level is low. Add fluid as required. 3. Remove pump from vehicle and separate reservoir from housing. Check expansion plug and housing for cracks. Replace pump as required. 4. Drain and refill fluid if there is evidence of contamination.

PUMP LEAKAGE DIAGNOSIS

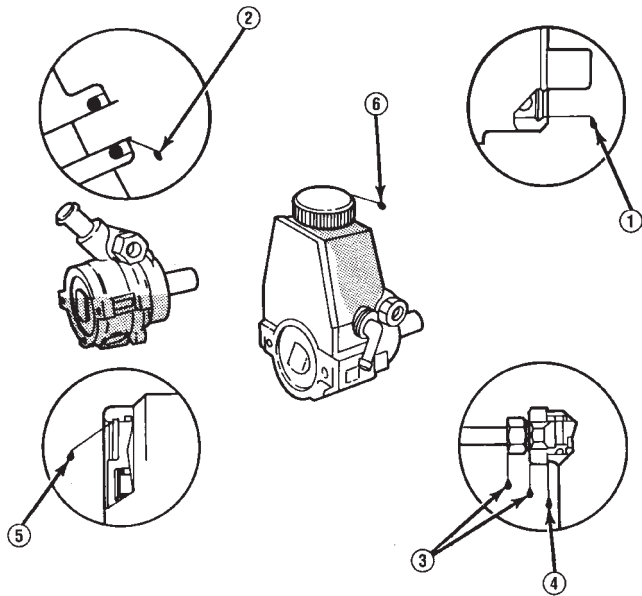

1. BUSHING (BEARING) WORN, SEAL WORN. REPLACE PUMP.
2. REPLACE RESERVOIR O-RING SEAL.
3. TORQUE HOSE FITTING NUT TO 35 N•m (25 ft. lbs.). IF LEAKAGE PERSISTS, REPLACE O-RING SEAL.
4. TORQUE FITTING TO 75 N•m (55 ft. lbs.). IF LEAKAGE PERSISTS, REPLACE O-RING SEAL.
5. REPLACE PUMP.
6. CHECK OIL LEVEL; IF LEAKAGE PERSISTS WITH THE LEVEL CORRECT AND CAP TIGHT, REPLACE THE CAP.

J9319-74

GEAR LEAKAGE DIAGNOSIS

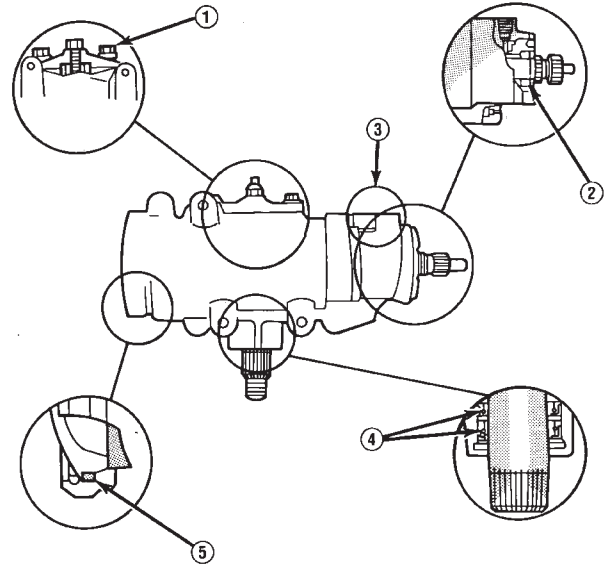

1. SIDE COVER LEAK - TORQUE SIDE COVER BOLTS TO 60 N•m (45 FT. LBS.). REPLACE THE SIDE COVER SEAL IF THE LEAKAGE PERSISTS.
2. ADJUSTER PLUG SEAL - REPLACE THE ADJUSTER PLUG SEALS.
3. PRESSURE LINE FITTING - TORQUE THE HOSE FITTING NUT TO 27 N•m (20 FT. LBS.). IF LEAKAGE PERSISTS, REPLACE THE SEAL.
4. PITMAN SHAFT SEALS - REPLACE THE SEALS.
5. TOP COVER SEAL - REPLACE THE SEAL.

J9319-75

POWER STEERING PUMP

INDEX

	page		page
Drive Pulley Replacement	13	Pump Replacement	12
Flow Control Valve Fitting O-Ring Seal	14	Reservoir Replacement	14
Power Steering Pump—Initial Operation	15	Service Information	11
Pressure and Return Hose Replacement	11		

SERVICE INFORMATION

The power steering pump internal components are not serviced or adjusted. If a malfunction or an internal fluid leak occurs, the complete unit must be replaced. A reservoir, cap, and O-ring seal kit are the only service components available.

PRESSURE AND RETURN HOSE REPLACEMENT

Cap hose open ends and pump/steering gear fittings to prevent entry of foreign material.

WARNING: POWER STEERING FLUID (AND PUMP COMPONENTS) AND THE EXHAUST SYSTEM CAN BE EXTREMELY HOT IF THE ENGINE HAS BEEN RECENTLY OPERATING. DO NOT START THE ENGINE WITH ANY LOOSE OR DISCONNECTED HOSES. DO NOT ALLOW THE HOSES TO TOUCH A HOT EXHAUST MANIFOLD OR THE CATALYTIC CONVERTER.

REMOVAL

- (1) Remove fasteners from hose retaining brackets at all locations.
- (2) If applicable, remove pressure sensor from pressure hose (Fig. 1, 2).
- (3) Disconnect pressure and return hose from the steering gear. Drain the fluid from pump and reservoir (Fig. 1, 2, 3).
- (4) Disconnect pressure and return hose from the pump. Remove hoses from vehicle (Fig. 1, 2, 3).

INSTALLATION

- (1) Wipe hose ends, pump and gear unions clean.
- (2) Connect hose at steering gear and pump. Route hose while avoiding extreme bends or kinks. **The hose must be kept away from exhaust system components.** Do not distort hose tube ends by bending, kinking or over tightening.
- (3) If applicable, install and tighten pressure sensor to 28 N·m (252 in. lbs.) torque (Fig. 1, 2).
- (4) When used, the protective foam sleeves must be properly positioned on the hose to prevent chafing.

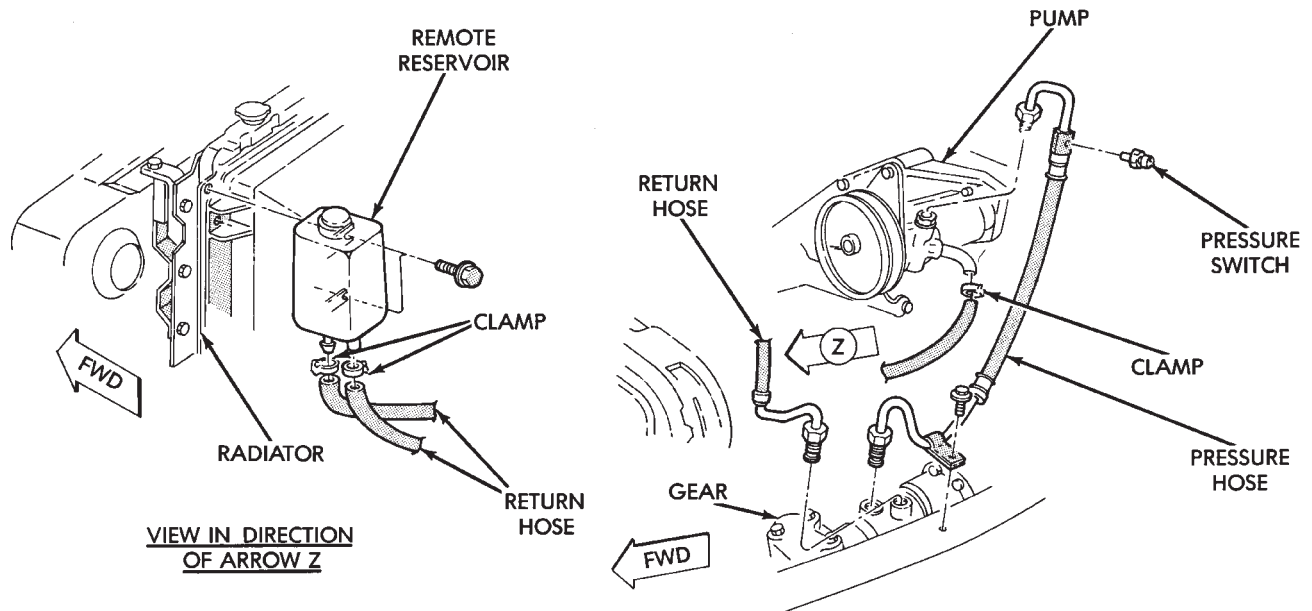

J9219-59

Fig. 1 Power Steering Hose—YJ

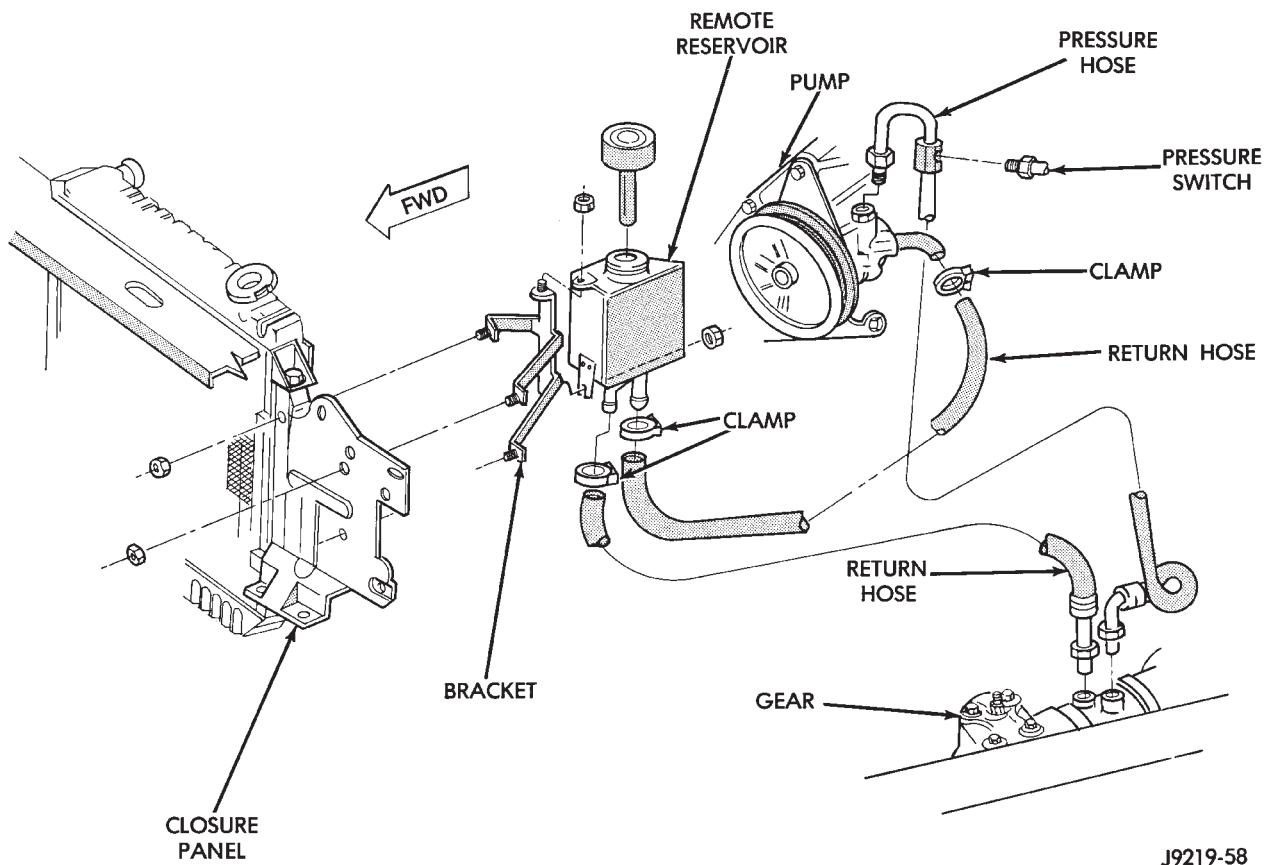

Fig. 2 Power Steering Hose—XJ 4 Cylinder

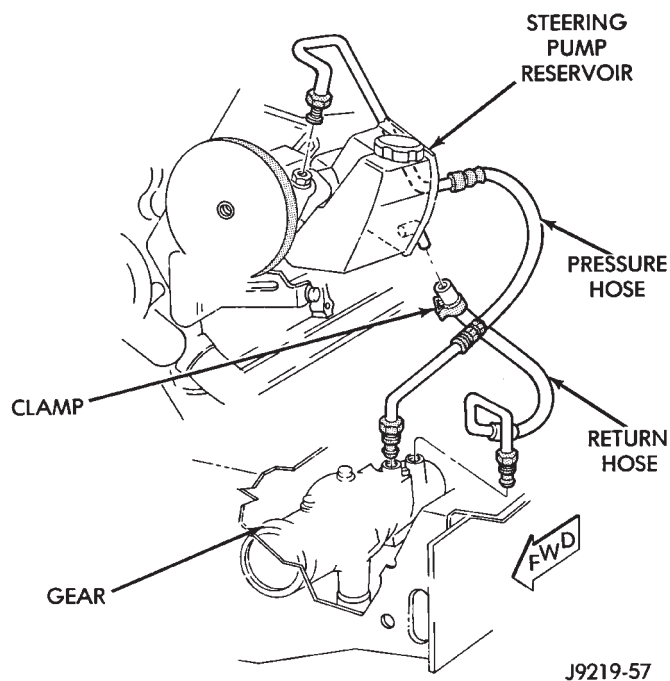

Fig. 3 Power Steering Hose—XJ 6 Cylinder

(5) Tighten fittings at pump and gear to 35 N·m (25 ft. lbs.) torque.

(6) Install clamps on return hose on gear, pump and reservoir.

(7) After installation, inspect and test for fluid leaks.

PUMP REPLACEMENT

REMOVAL

CAUTION: The drive belt tension must be released before removing the pump. If the belt is not loosened, the pump pulley could be damaged.

(1) Remove serpentine drive belt. Refer to Group 7, Cooling for additional information.

(2) Place a drain pan under pump.

(3) Remove pressure and return hoses from pump. Refer to Pressure and Return Hose Replacement in this section.

(4) Remove 2 rear bracket-to-pump bolts (Fig. 4).

(5) Remove lower nut at adjustment bracket.

(6) Remove adjuster bolt.

(7) Remove upper pivot bolt.

(8) Tilt pump forward and remove pump and front bracket assembly from engine bracket.

(9) Remove adjuster collar at lower stud on pump bracket.

(10) Remove pulley from pump. Refer to Drive Pulley Replacement in this section (Fig. 5).

(11) Remove 3 front bracket-to-pump bolts.

FASTENER TORQUE			
LETTER	N•m	IN. LBS.	FT. LBS.
A	57	—	42
B	28	250	21
C	47	—	35

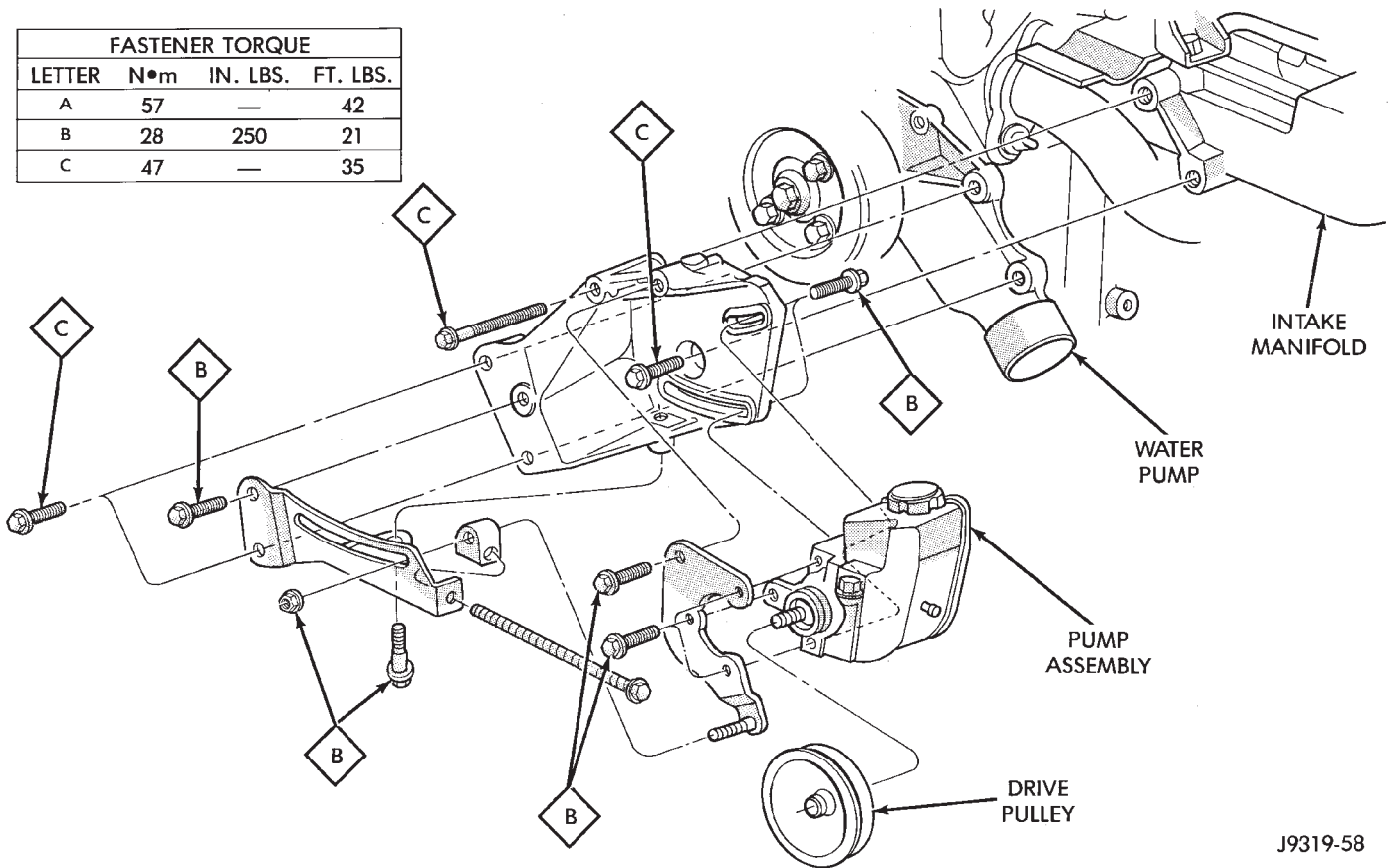

J9319-58

Fig. 4 Pump Mounting—6 Cylinder

INSTALLATION

- (1) Install 3 front bracket-to-pump bolts. Tighten to 28 N•m (21 ft. lbs.) torque.
- (2) Install pulley on pump. Refer to Drive Pulley Replacement in this section (Fig. 6).
- (3) Install adjuster collar on adjuster bracket stud (Fig. 4).
- (4) Tilt pump forward and install pump onto engine bracket.
- (5) Install upper pivot bolt.
- (6) Install lower adjuster bolt.
- (7) Install lower adjuster stud nut.
- (8) Install 2 rear engine bracket to pump bolts. Tighten to 28 N•m (21 ft. lbs.) torque.
- (9) Install the serpentine drive belt. Refer to Group 7, Cooling for additional information.
- (10) Install the pressure and return hoses to pump. Refer to Pressure and Return Hose Replacement in this section.
- (11) Add power steering fluid. Refer to Power Steering Pump Initial Operation in this section.

DRIVE PULLEY REPLACEMENT

REMOVAL

- (1) Remove power steering pump. Refer to Pump Replacement in this section.

- (2) Remove the drive pulley with Puller C-4333 (Fig. 5).

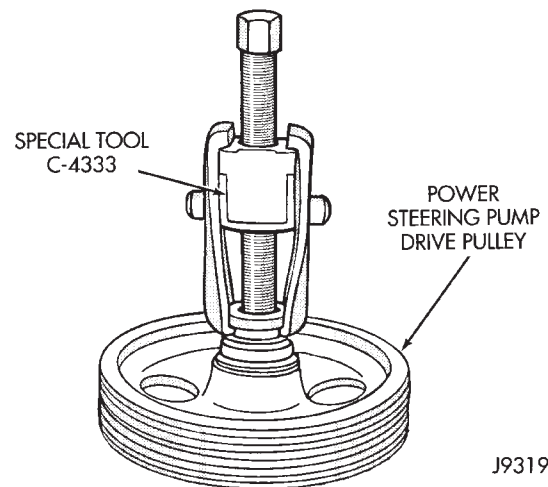

J9319-45

Fig. 5 Remove Drive Pulley—Typical

Do not hammer on any part of drive pulley, damage will occur to the pump and pulley.

INSTALLATION

- (1) Install the pulley with Installer C-4063-B (Fig. 6). Do not use the tool adapters.

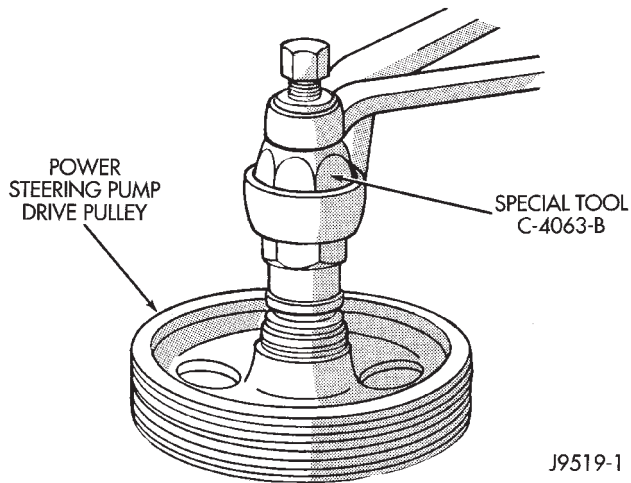

Fig. 6 Install Drive Pulley—Typical

(2) Be sure tool and pulley remain aligned and NOT cocked with the pump shaft.

(3) Press the pulley on flush with end of pump shaft (Fig. 7).

(4) Install power steering pump. Refer to Pump Replacement in this section.

With Serpentine Belts; Run engine until warm (5 min.) and note any belt chirp. If chirp exists, move pulley outward approximately 0.5 mm (0.020 in.). If noise increases, press on 1.0 mm (0.040 in.). **Be careful that pulley does not contact mounting bolts.**

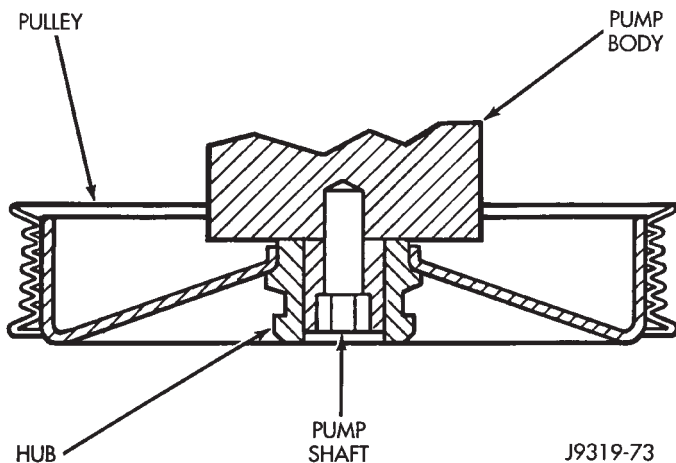

Fig. 7 Pump Shaft Location

RESERVOIR REPLACEMENT

REMOVAL

(1) Remove power steering pump. Refer to Pump Replacement in this section.

(2) Clean exterior of pump with solvent.

(3) Clamp the pump body in a soft jaw vice.

(4) Pry up tab and slide the retaining clip off (Fig. 8).

(5) Remove fluid reservoir from pump body. Remove and discard O-ring seal (Fig. 9).

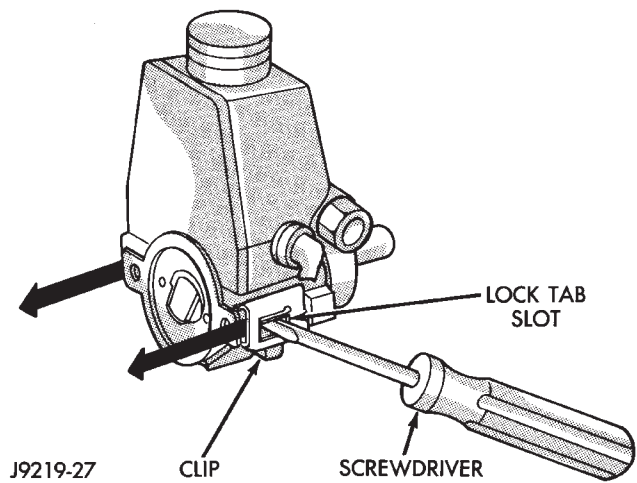

Fig. 8 Remove Reservoir Clips—Typical

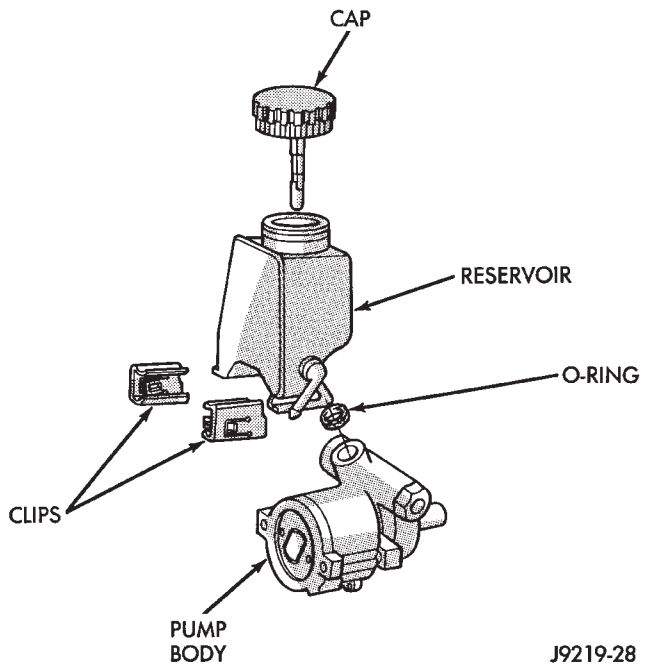

Fig. 9 Remove Reservoir—Typical

INSTALLATION

(1) Lubricate new O-ring Seal with Mopar Power Steering Fluid or equivalent.

(2) Install O-ring seal in housing.

(3) Install reservoir onto housing.

(4) Slide and tap in reservoir retainer clips until tab locks to housing.

(5) Install power steering pump. Refer to Pump Replacement in this section.

FLOW CONTROL VALVE FITTING O-RING SEAL

REMOVAL

(1) Clean area around fitting to prevent dirt from entering pump. Remove pressure hose from pump fitting.

(2) Remove fitting from pump housing (Fig. 10). **Prevent flow control valve and spring from sliding out of housing bore.**

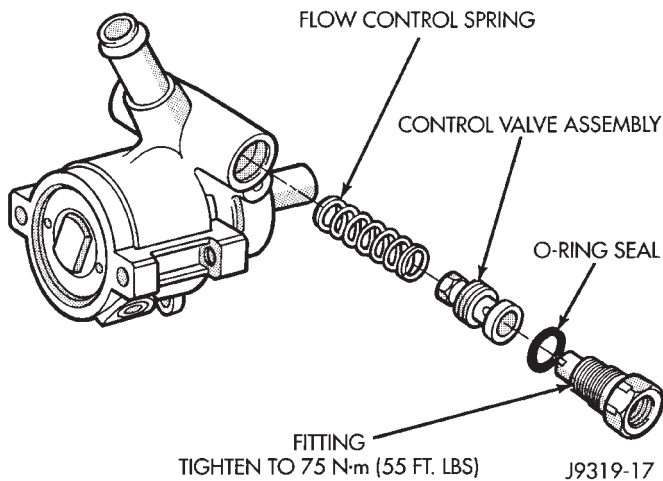

Fig. 10 Flow Control Valve Fitting

(3) Remove and discard O-ring seal.

INSTALLATION

- (1) If necessary, clean and install flow control valve and spring in pump housing bore. **Be sure the hex nut end of the valve is facing in toward pump.**
- (2) Install O-ring seal onto fitting (Fig. 10).
- (3) Install flow control valve in pump housing and tighten to 75 N·m (55 ft. lbs.) torque.
- (4) Install pressure hose to valve.

POWER STEERING PUMP—INITIAL OPERATION

CAUTION: The fluid level should be checked with engine off to prevent injury from moving components. Use only Mopar Power Steering Fluid. Do not use automatic transmission fluid. Do not overfill.

Wipe filler cap clean, then check the fluid level. The dipstick should indicate FULL COLD when the fluid is at normal temperature 21°C to 27°C (70°F to 80°F).

- (1) Fill the pump fluid reservoir to the proper level and let the fluid settle for at least two (2) minutes.
- (2) Start the engine and let run for a few seconds. Then turn the engine off.
- (3) Add fluid if necessary. Repeat the above procedure until the fluid level remains constant after running the engine.
- (4) Raise the front wheels off the ground.
- (5) Start the engine. Slowly turn the steering wheel right and left, lightly contacting the wheel stops.
- (6) Add power steering fluid if necessary.
- (7) Lower the vehicle and turn the steering wheel slowly from lock to lock.
- (8) Stop the engine. Check the fluid level and refill as required.
- (9) If the fluid is extremely foamy, allow the vehicle to stand a few minutes and repeat the above procedure.

STEERING LINKAGE—XJ

INDEX

	page		page
Drag Link	16	Steering Damper	17
Pitman Arm	17	Tie Rod	16
Service Information	16		

SERVICE INFORMATION

The steering linkage consists of a pitman arm, drag link, tie rod, and steering damper. Adjustment sleeves are used on the tie rod and drag link for toe and steering wheel alignment.

Refer to Group 2, Front Suspension and Axle for additional information.

The tie-rod end ball stud seals should be inspected during all oil changes.

A damaged ball stud seal requires removal of the seal. Inspect the tie-rod end ball stud at the throat opening. Check for lubricant loss, contamination, ball stud wear or corrosion. If these conditions exist, replace the tie-rod. A replacement seal can be installed if lubricant is in good condition. Otherwise, a complete replacement ball stud end should be installed. Lubricate the tie-rod end with MOPAR® Multi-Mileage Lubricant, or equivalent product.

Use a Puller tool C-3894-A for tie rod removal. Failure to use this tool could damage the ball stud and seal (Fig. 1).

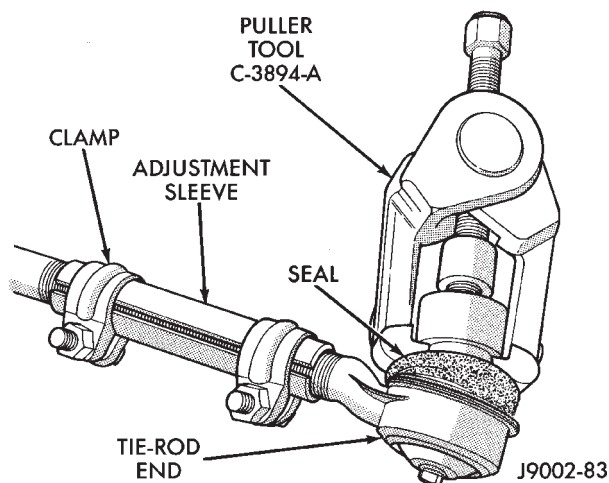

Fig. 1 Ball Stud Removal

TIE ROD

REMOVAL

(1) Remove the cotter pins and nuts at the tie rod ball studs and drag link (Fig. 2).

(2) Loosen the ball studs with a puller tool to remove the tie rod.

(3) If necessary, loosen the end clamp bolts and remove the tie rod ends from the tube.

INSTALLATION

(1) If necessary, install the tie rod ends in the tube (Fig. 2). Position the tie rod clamp as shown (Fig. 3) and tighten to 27 N·m (20 ft. lbs.) torque.

(2) Install the tie rod on the drag link and steering knuckle. Install the retaining nuts.

(3) Tighten the ball stud nut on the steering knuckle to 47 N·m (35 ft. lbs.) torque. Tighten the ball stud nut to drag link to 75 N·m (55 ft. lbs.) torque. Install new cotter pins.

DRAG LINK

REMOVAL

The drag link ball stud cannot be disassembled for service.

(1) Remove the steering damper ball stud from the drag link with a puller tool.

(2) Remove the drag link from the steering knuckle with a puller tool. Remove the same for tie rod and pitman arm.

(3) If necessary, loosen the end clamp bolts and remove the tie rod end from the link.

INSTALLATION

(1) Install the drag link adjustment sleeve and tie rod end. Position clamp bolts as shown (Fig. 3).

(2) Position the drag link at the steering linkage (Fig. 2).

Install the nut that attach the drag link to the steering knuckle. Do the same for the tie rod and pitman arm.

(3) Tighten the nut at the steering knuckle to 47 N·m (35 ft. lbs.) torque. Tighten the pitman and tie rod ball stud nuts to 75 N·m (55 ft. lbs.) torque. Install new cotter pins.

(4) Install the steering damper onto the drag link. Tighten the nut to 47 N·m (35 ft. lbs.) torque. Install a new cotter pin.

FASTENER TORQUE			
LETTER	N•m	IN. LBS.	FT. LBS.
◇	251	—	185
◇			
◇	74	—	55
◇			
◇	49	—	36
◇	27	—	20

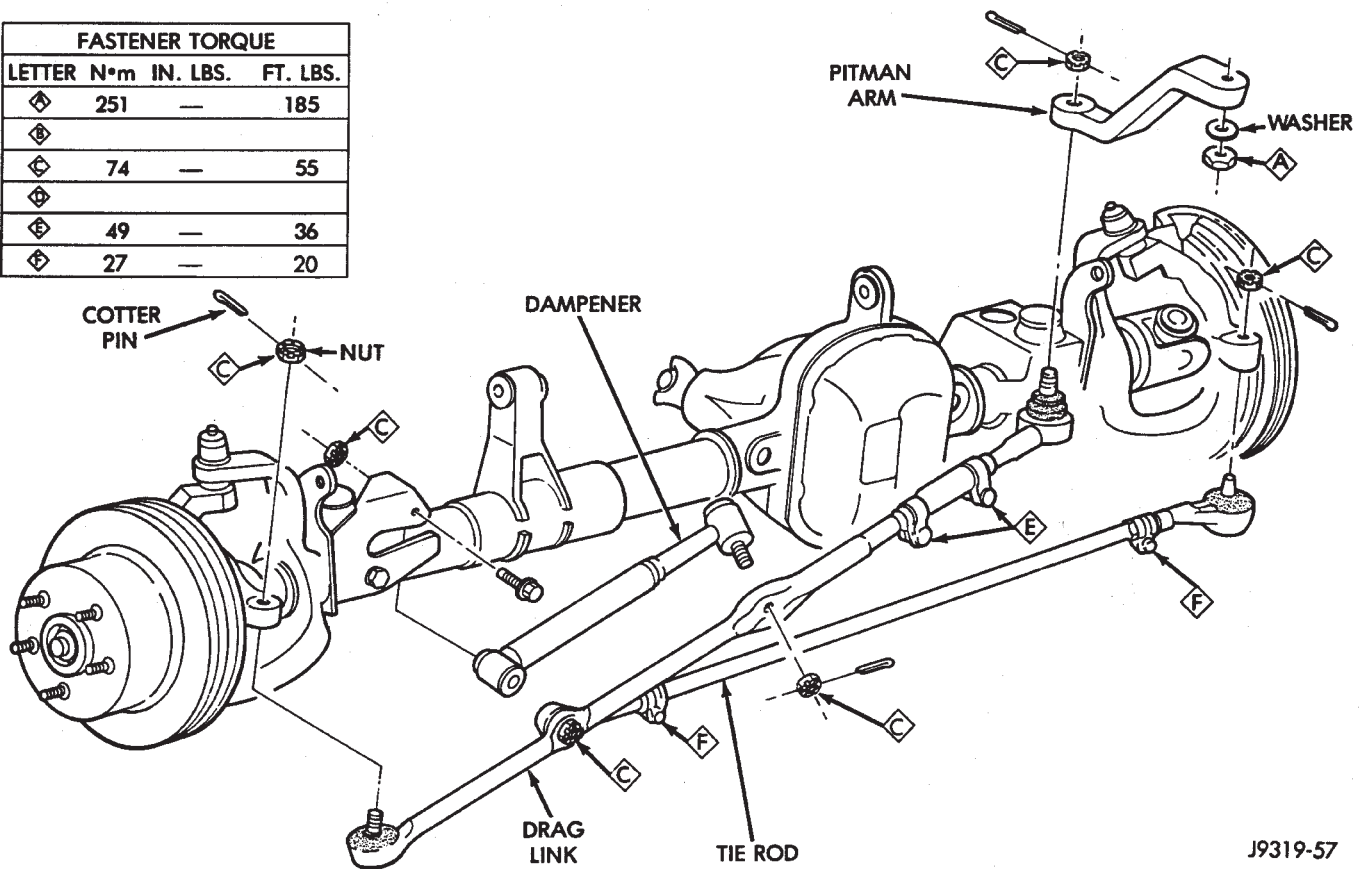

Fig. 2 Steering Linkage

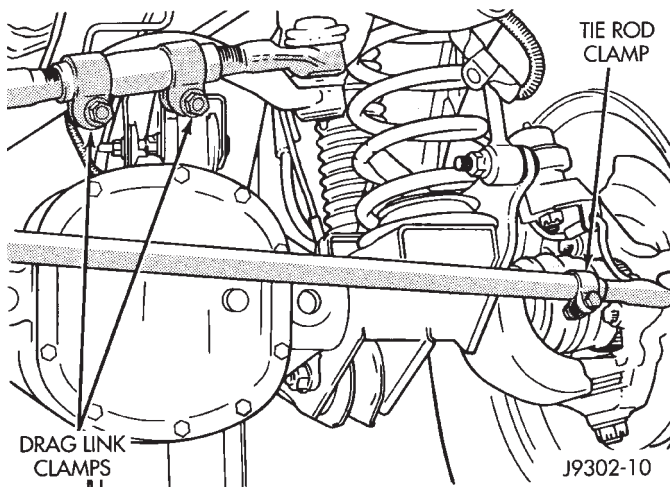

Fig. 3 Tie Rod/Drag Link Clamp Bolt

STEERING DAMPER

REMOVAL

- (1) Place the front wheels in a straight-ahead position.
- (2) Remove the steering damper retaining nut and bolt from the axle bracket (Fig. 2).
- (3) Remove the cotter pin and nut from the ball stud at the drag link (Fig. 2).

- (4) Remove the steering damper ball stud from the drag link with a puller tool.

INSTALLATION

- (1) Install the steering damper to the axle bracket and drag link.
- (2) Install the steering damper bolt in the axle bracket. Tighten the nut to 75 N•m (55 ft. lbs.) torque.
- (3) Install the ball stud nut at the drag link. Tighten the nut to 75 N•m (55 ft. lbs.) torque. Install a new cotter pin.

PITMAN ARM

REMOVAL

- (1) Remove the cotter pin and nut from the drag link at the pitman arm.
- (2) Remove the drag link ball stud from the pitman arm with a puller.
- (3) Remove the nut and washer from the steering gear shaft. Mark the pitman shaft and pitman arm for installation reference. Remove the pitman arm from steering gear with Puller C-4150-A (Fig. 4).

INSTALLATION

- (1) Align and install the pitman arm on steering gear shaft.

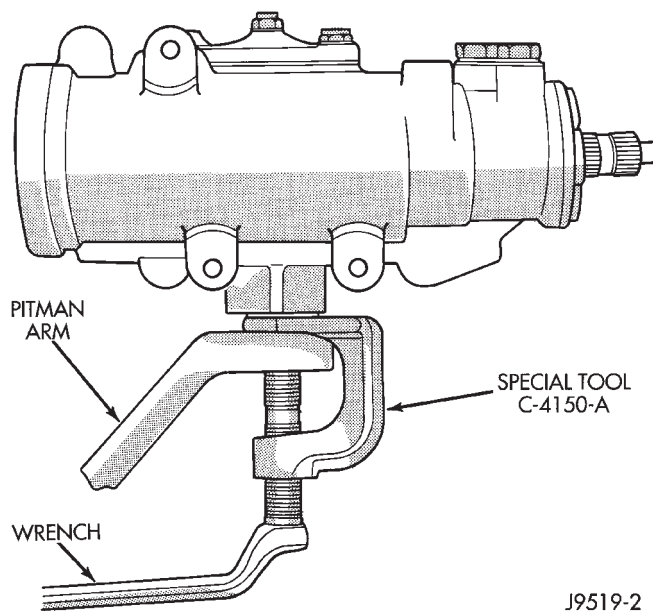

Fig. 4 Pitman Arm Removal

(2) Install the washer and nut on the shaft. Tighten the nut to 251 N·m (185 ft. lbs.) torque.

(3) Install drag link ball stud to pitman arm (Fig. 4). Install and tighten nut to 74 N·m (55 ft. lbs.) torque. Install a new cotter pin.

STEERING LINKAGE—YJ

INDEX

	page		page
Drag Link	20	Steering Damper	20
Pitman Arm	20	Tie Rod	19
Service Information	19		

SERVICE INFORMATION

The steering linkage consists of a pitman arm, drag link, tie rod, and steering damper. Adjustment sleeves are used on the tie rod and drag link for toe and steering wheel alignment.

Refer to Group 2, Front Suspension and Axle for additional information.

The tie-rod end ball stud seals should be inspected during all oil changes.

A damaged ball stud seal requires removal of the seal. Inspect the tie-rod end ball stud at the throat opening. Check for lubricant loss, contamination, ball stud wear or corrosion. If these conditions exist, replace the tie-rod. A replacement seal can be installed if lubricant is in good condition. Otherwise, a complete replacement ball stud end should be installed. Lubricate the tie-rod end with MOPAR® Multi-Mileage Lubricant, or equivalent product.

Use Puller C-3894-A for tie rod removal. Failure to use this tool could damage the ball stud and seal (Fig. 1).

TIE ROD

REMOVAL

(1) Remove the cotter pins and nuts at the steering knuckles and drag link (Fig. 2). Remove the steering damper from the tie rod.

(2) Loosen the ball studs with a puller tool to remove the tie rod.

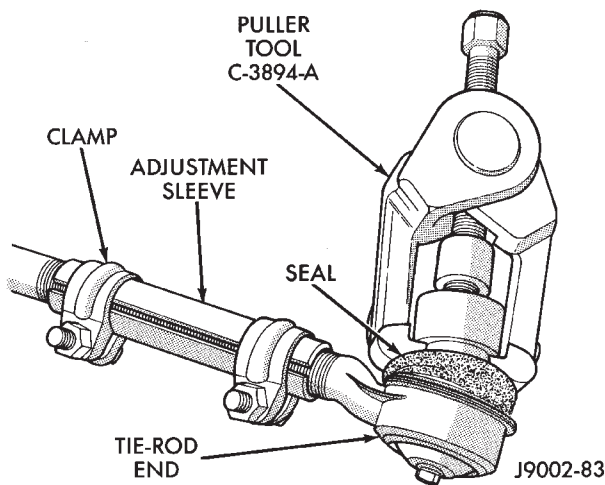

Fig. 1 Ball Stud Removal

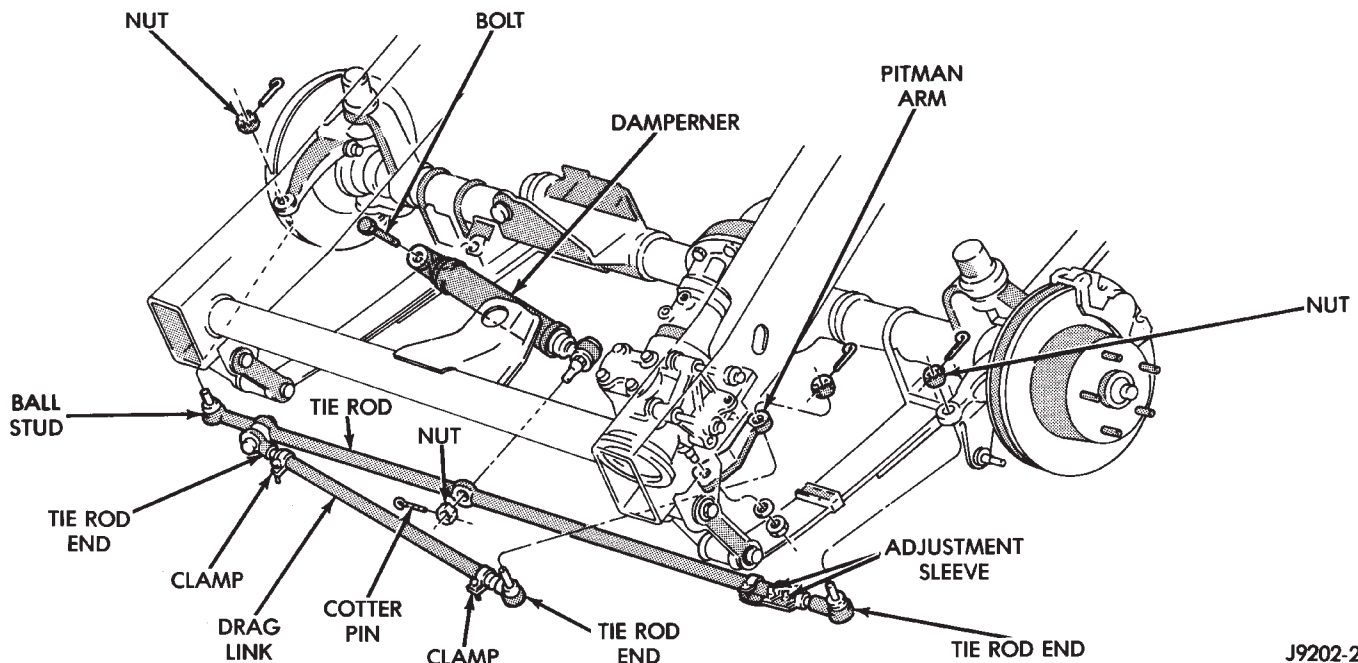

Fig. 2 Steering Linkage

(3) If necessary, loosen the end clamp bolts and remove the tie rod end from the tube.

INSTALLATION

(1) If necessary, install the tie rod end in the tube (Fig. 2). Position the tie rod clamp as shown (Fig. 3). Tighten the ball-stud end clamp bolts to 49 N·m (36 ft. lbs.) torque.

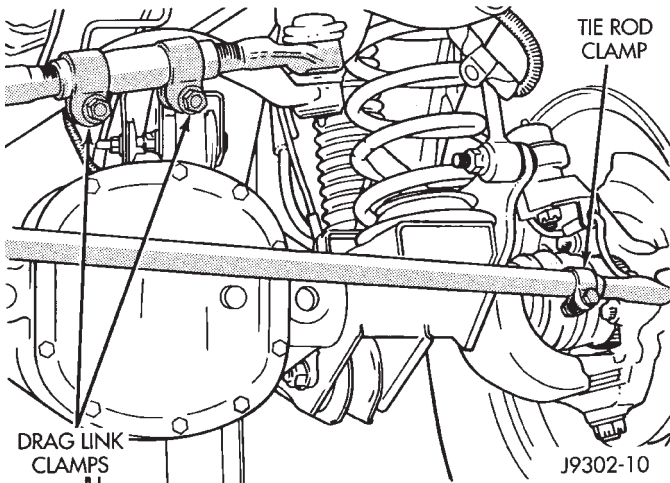

Fig. 3 Tie Rod/Drag Link Clamp Bolt

(2) Install the tie rod on the drag link and steering knuckles. Install the retaining nuts. Install the steering damper to the tie rod.

(3) Tighten the ball stud nut on the steering knuckle to 47 N·m (35 ft. lbs.) torque. Tighten the ball stud nut to drag link to 75 N·m (55 ft. lbs.) torque. Tighten the steering damper nut to 74 N·m (55 ft. lbs.) torque. Install new cotter pins.

DRAG LINK

REMOVAL

(1) Remove the cotter pins and nuts at the tie rod and pitman arm (Fig. 2).

(2) Remove the drag link from the tie rod and pitman arm with a puller tool.

(3) If necessary, loosen the end clamp bolts and remove the tie rod ends from the tube.

INSTALLATION

(1) Install the drag link adjustment sleeve and tie rod ends. Position clamp bolts as shown (Fig. 3).

(2) Position the drag link at the steering linkage (Fig. 2).

Install the drag link to tie rod and pitman arm.

(3) Tighten the nut at the pitman arm to 74 N·m (55 ft. lbs.) torque. Tighten the tie rod ball stud nut to 75 N·m (55 ft. lbs.) torque. Install new cotter pins.

STEERING DAMPER

REMOVAL

(1) Place the front wheels in a straight-ahead position.

(2) Remove the steering damper retaining nut and bolt from the axle bracket (Fig. 2).

(3) Remove the cotter pin and nut from the ball stud at the tie rod (Fig. 2).

(4) Remove the steering damper ball stud from the tie rod with a puller tool.

INSTALLATION

(1) Install the steering damper to the axle bracket and tie rod.

(2) Install the steering damper bolt in the axle bracket. Tighten the nut to 74 N·m (55 ft. lbs.) torque.

(3) Install the ball stud nut at the tie rod. Tighten the nut to 74 N·m (55 ft. lbs.) torque. Install a new cotter pin.

PITMAN ARM

REMOVAL

(1) Remove the cotter pin and nut from the drag link at the pitman arm.

(2) Remove the drag link ball stud from the pitman arm with a puller.

(3) Remove the nut and washer from the steering gear shaft. Mark the pitman shaft and pitman arm for installation reference. Remove the pitman arm from steering gear with Puller C-4150-A (Fig. 4).

INSTALLATION

(1) Align and install the pitman arm on steering gear shaft.

(2) Install the washer and nut on the shaft. Tighten the nut to 251 N·m (185 ft. lbs.) torque.

(3) Install drag link ball stud to pitman arm (Fig. 4). Install and tighten nut to 74 N·m (55 ft. lbs.) torque. Install a new cotter pin.

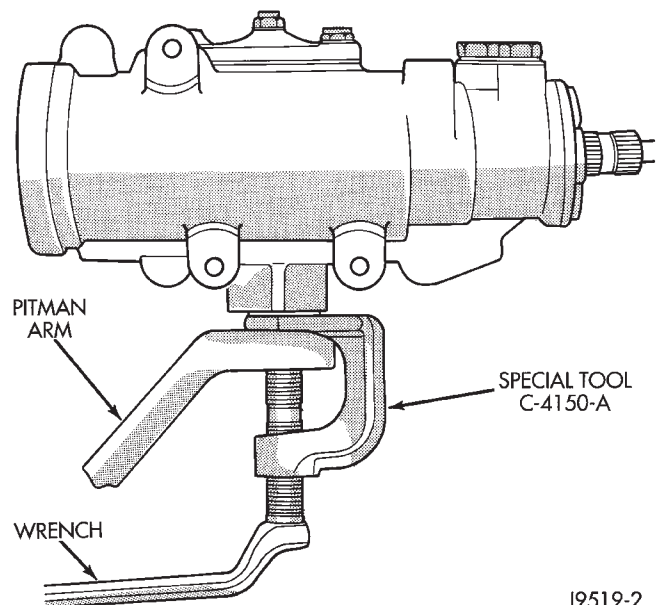

Fig. 4 Pitman Arm Removal

RECIRCULATING BALL POWER STEERING GEAR

INDEX

	page		page
Adjuster Plug Assembly Replacement	29	Pitman Shaft Seals—In Car Replacement	23
Check Valve Replacement	35	Rack Piston and Worm Shaft Replacement	32
Gear Disassembly Information	26	Service Information	21
Housing End Plug	28	Steering Gear Adjustments	24
Intermediate—Coupling Shaft	23	Steering Gear Replacement	23
Pitman Shaft and Side Cover Replacement	28	Valve Replacement	30
Pitman Shaft Seals and Bearing Replacement	34		

SERVICE INFORMATION

A recirculating-ball steering gear is used with the power (assisted) steering system (Fig. 1). The power steering gear can be adjusted and internally serviced.

Discard all O-ring seals during disassembly, they are not re-usable.

Safety goggles should be worn at all times when involved with power steering gear or pump service.

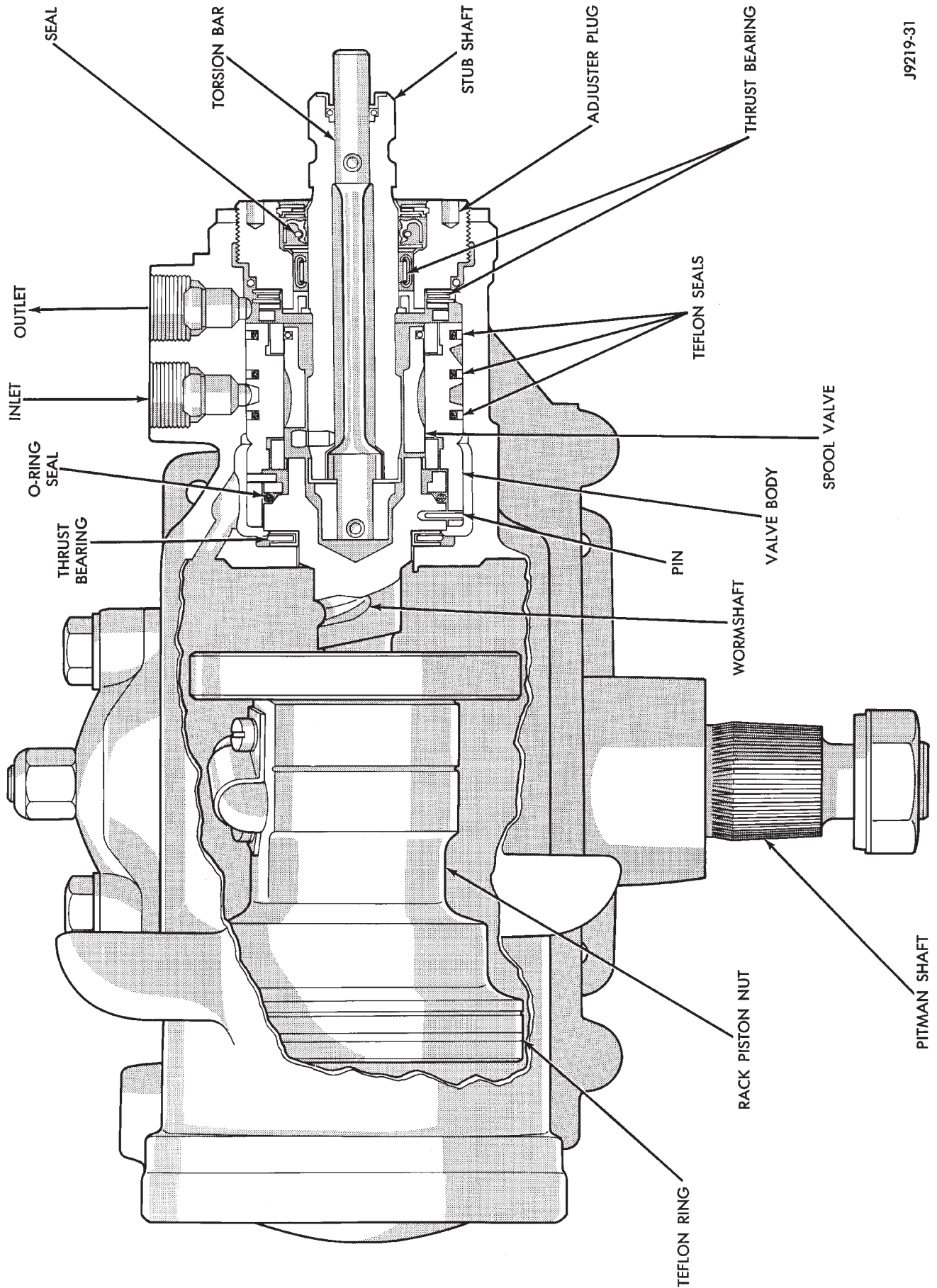

J9219-31

Fig. 1 Power Steering Gear

PITMAN SHAFT SEALS—IN CAR REPLACEMENT

REMOVAL

- (1) Remove pitman arm from gear. Refer to Pitman Arm Removal in Steering Linkage.
- (2) Clean exposed end of pitman shaft and housing. Use a wire brush to clean the shaft splines.
- (3) Remove retaining ring with snap ring pliers (Fig. 2).

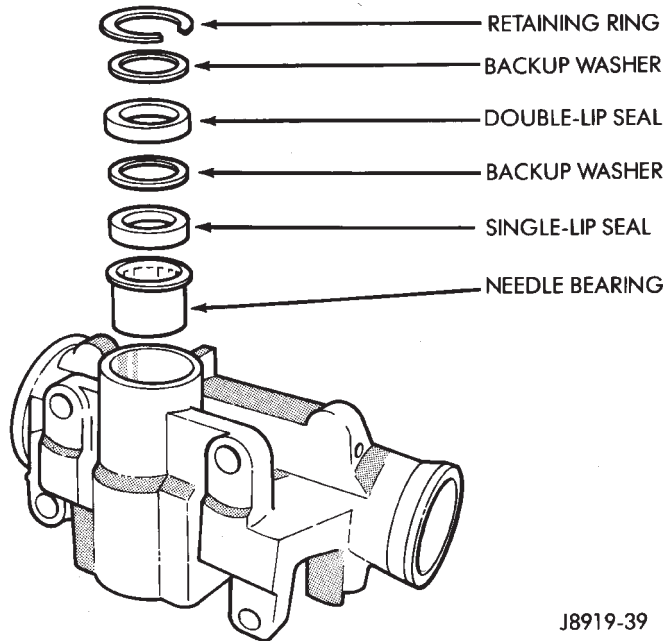

Fig. 2 Pitman Shaft Seals

CAUTION: Use care not to score the housing bore when prying out seals and washers.

- (4) Remove backup washer and double lip seal with screwdriver.

- Start the engine and turn the steering wheel fully to the LEFT to force out the seals and washers.
- Stop the engine

- (5) Remove backup washer and single lip seal with screwdriver.

- (6) Inspect the housing for burrs and remove if necessary. Inspect the pitman shaft seal surface for roughness and pitting. If pitted replace shaft.

INSTALLATION

- (1) Install single lip seal with Installer or a suitable size deep socket (Fig. 3).
- (2) Coat the double lip seal and washer with grease.
- (3) Install the backup washer.
- (4) Install the double lip seal.
- (5) Install the backup washer.
- (6) Install the retainer ring with snap ring pliers.
- (7) Center the steering gear.
- (8) Install the pitman arm. Refer to Pitman Arm Installation in Steering Linkage.

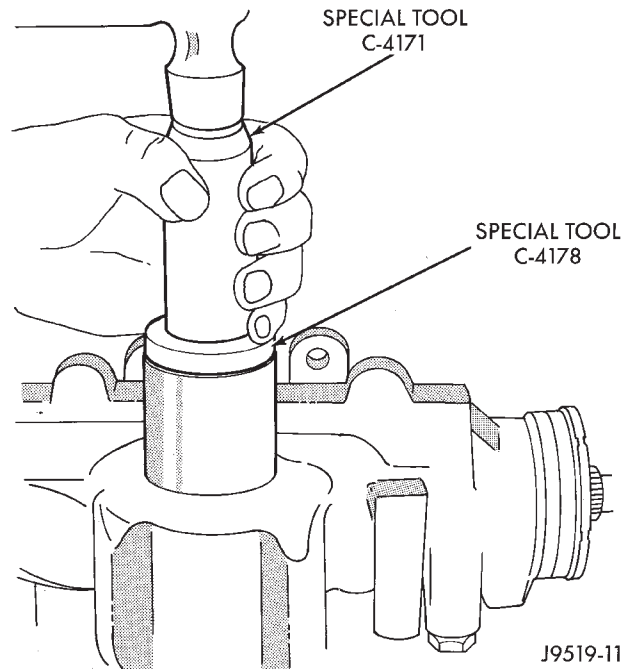

Fig. 3 Pitman Shaft Seal Installation

- (9) Add power steering fluid. Refer to Power Steering Initial Operation.

INTERMEDIATE—COUPLING SHAFT

REMOVAL

- (1) Place the front wheels in the straight ahead position.
- (2) Remove the shaft pinch bolt at the steering gear and column (Fig. 4, 5). Unbolt steering gear from frame rail to remove shaft. Refer to Steering Gear Replacement in this section.

INSTALLATION

- (1) Align the intermediate (coupler) shaft to the steering gear and column.
- (2) Position the steering gear on the frame. Refer to Steering Gear Replacement in this section.
- (3) Install and tighten the pinch bolts to 34 N·m (25 ft. lbs.) torque.

STEERING GEAR REPLACEMENT

REMOVAL

- (1) Place the front wheels in the straight ahead position with the steering wheel centered.
- (2) Disconnect and cap the fluid hoses from steering gear. Refer to Pressure and Return Hose Replacement in this Group.
- (3) Remove the column coupler shaft from the gear. Refer to the removal procedures in this section.
- (4) Remove pitman arm from gear. Refer to Pitman Arm Removal in the Steering Linkage section.

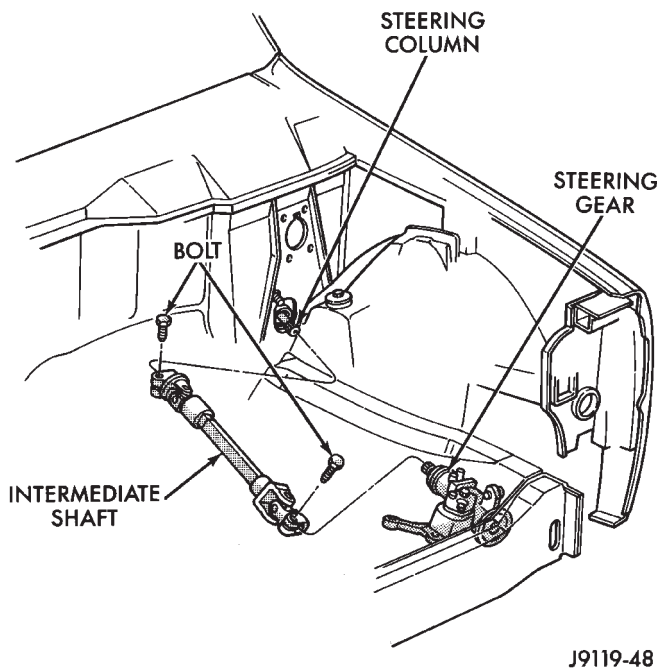

Fig. 4 Coupler Shaft—XJ

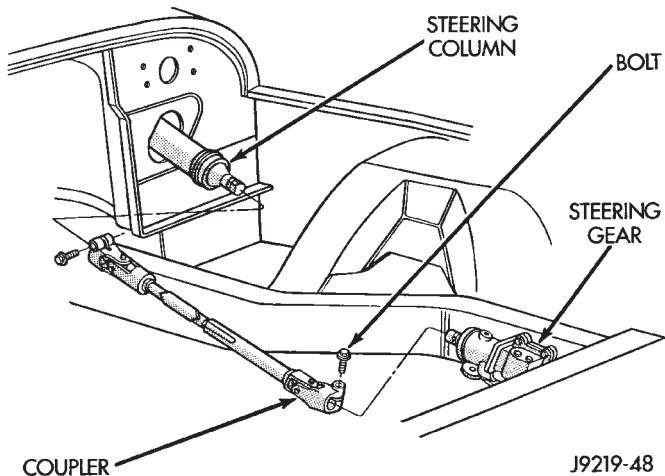

Fig. 5 Coupler Shaft—YJ

(5) Remove the steering gear retaining bolts and nuts. Remove the steering gear from the vehicle (Fig. 6, 7).

INSTALLATION

(1) Align the column coupler shaft to steering gear. Refer to Column Coupler installation in this section.
 (2) Position the steering gear (and bracket) on the frame rail and install the bolts.

- XJ—Tighten the bolts to 95 N·m (70 ft. lbs.) torque
- YJ—Tighten the bolts to 105 N·m (78 ft. lbs.) torque

(3) Align and install the pitman arm. Refer to Pitman Arm Installation in the Steering Linkage section.

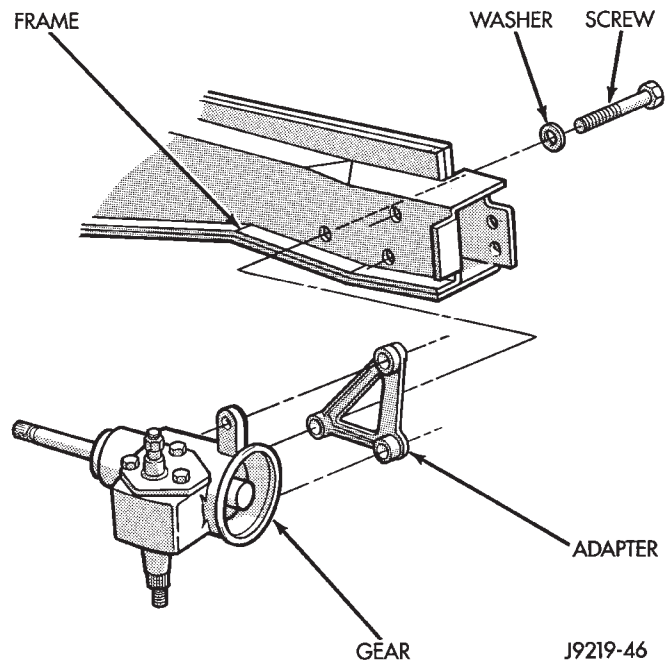

Fig. 6 Steering Gear Mounting—XJ

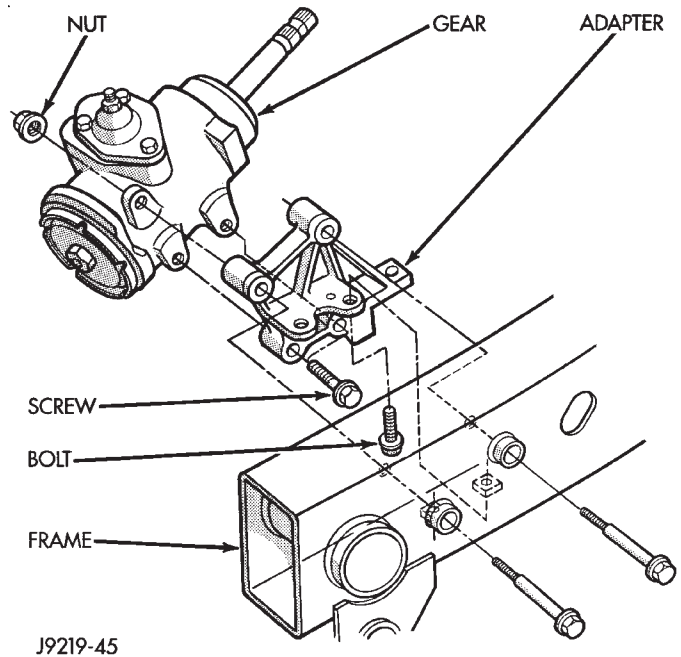

Fig. 7 Steering Gear Mounting—YJ

(4) Connect fluid hoses to steering gear. Refer to Pressure and Return Hose Replacement in this Group.

STEERING GEAR ADJUSTMENTS

SERVICE INFORMATION

Adjusting the steering gear in the vehicle is **NOT** recommended. Remove the gear from the vehicle and mount in a vise. Drain the power steering fluid and make the following adjustments in this order:

- **FIRST** - worm thrust bearing preload

- SECOND - over-center preload adjustment

WORM THRUST BEARING PRELOAD ADJUSTMENT

(1) Remove adjuster plug locknut (Fig. 8).

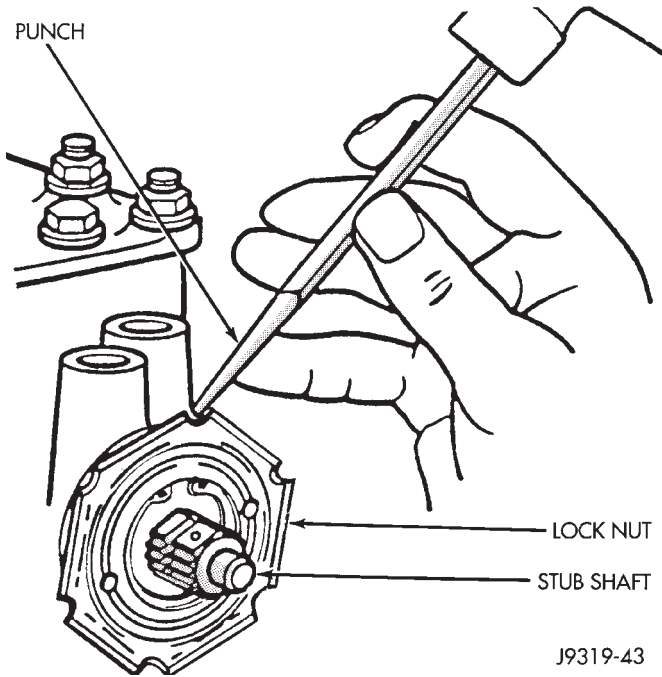

Fig. 8 Loosening the Adjuster Plug Locknut

(2) Turn the adjuster in with Spanner Wrench C-4381. Tighten the plug and thrust bearing in the housing until firmly bottomed in housing.

(3) Place an index mark on the housing even with one of the holes in adjuster plug (Fig. 9).

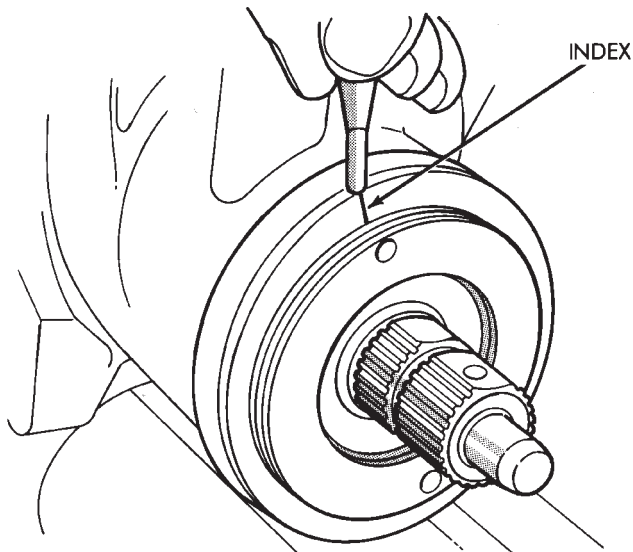

Fig. 9 Alignment Marking On Housing

(4) Measure back (counterclockwise) 13 mm (0.50 in) and mark housing (Fig. 10).

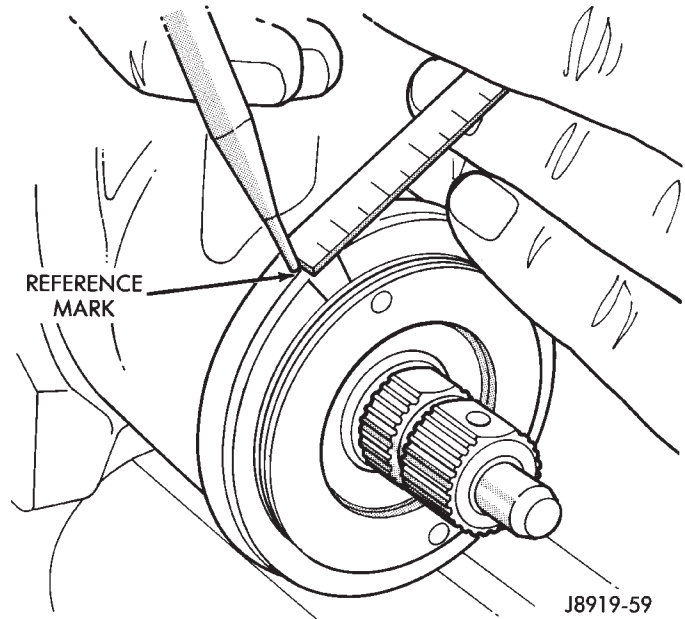

Fig. 10 Remarking The Housing

(5) Rotate adjustment cap back (counterclockwise) with spanner wrench until hole is aligned with the second mark (Fig. 11).

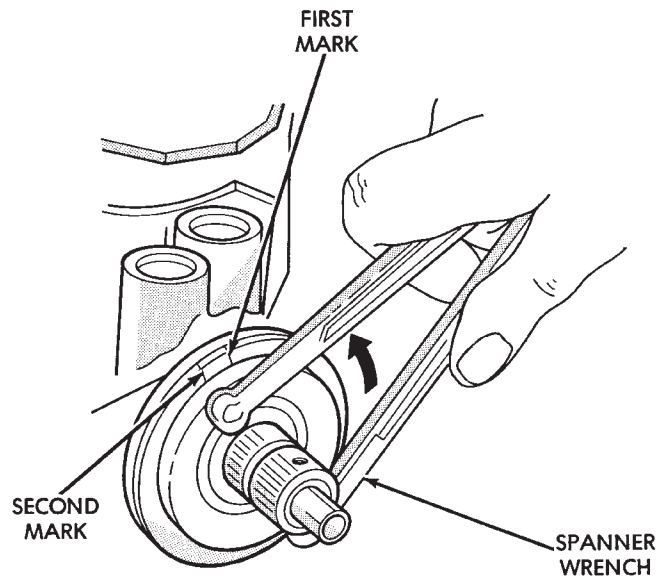

Fig. 11 Aligning To The Second Mark

(6) Install and tighten locknut to 109 N·m (80 ft. lbs.) torque. Be sure adjustment cap does not turn while tightening the locknut.

OVER-CENTER ADJUSTMENT

(1) Rotate the stub shaft from stop to stop and count the number of turns.

(2) Starting at either stop turn the stub shaft back 1/2 the total number of turns. This is the center of the gear travel (Fig. 12).

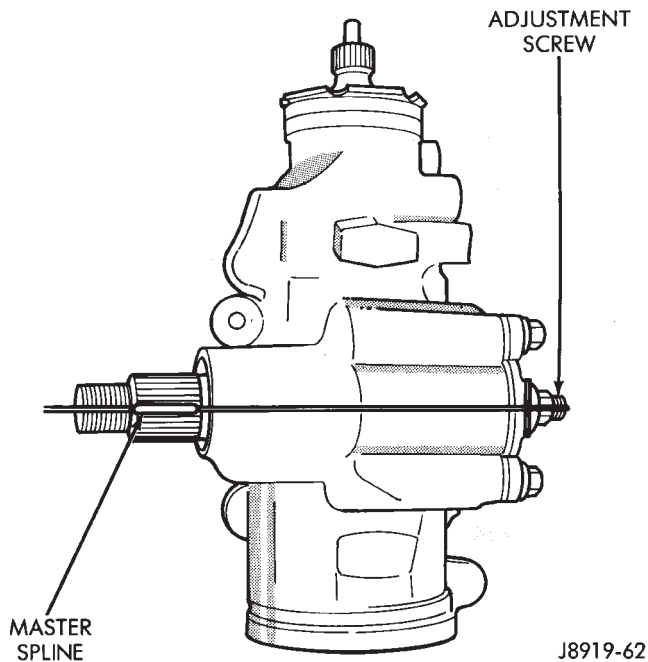

Fig. 12 Steering Gear Centered

(3) Turn the pitman shaft adjuster screw back (COUNTERCLOCKWISE) until extended, then turn back in (CLOCKWISE) one full turn.

(4) Place the torque wrench in the vertical position on the stub shaft. Rotate the wrench 45 degrees each side of the center and record the highest rotational torque on center (Fig. 13).

(5) Turn the adjuster in until torque to turn stub shaft is 0.6 to 1.2 N·m (6.0 to 10.0 in. lbs.) more than reading in Step 4.

(6) Prevent the adjuster screw from turning while tightening adjuster lock nut. Tighten the adjuster lock nut to 49 N·m (36 ft. lbs.).

GEAR DISASSEMBLY INFORMATION

CAUTION: Cleanliness is extremely important when repairing a power steering gear. Keep the bench, tools and components clean at all times. Thoroughly clean the exterior of the gear with cleaning solvent before disassembly. Drain as much of the fluid as possible. Use protective vise jaws at all times when clamping components. During assembly, lubricate all components with power steering fluid except where noted (Fig. 14).

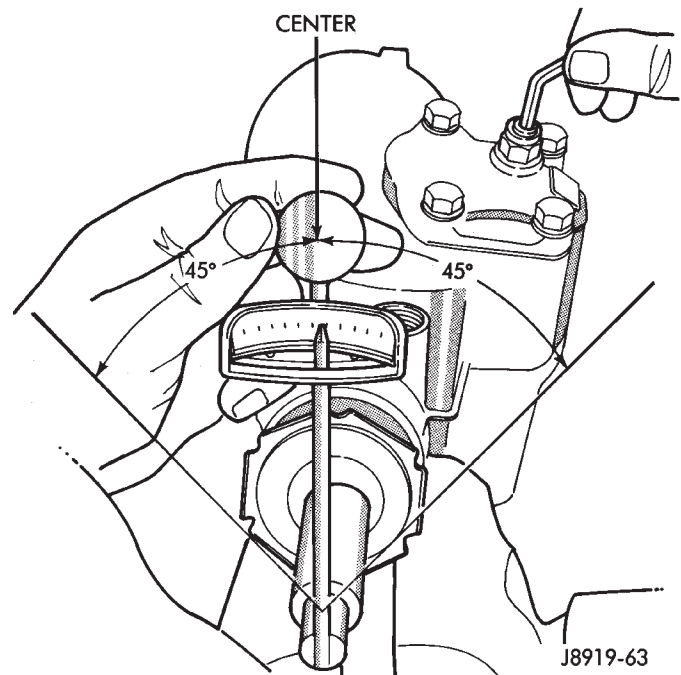
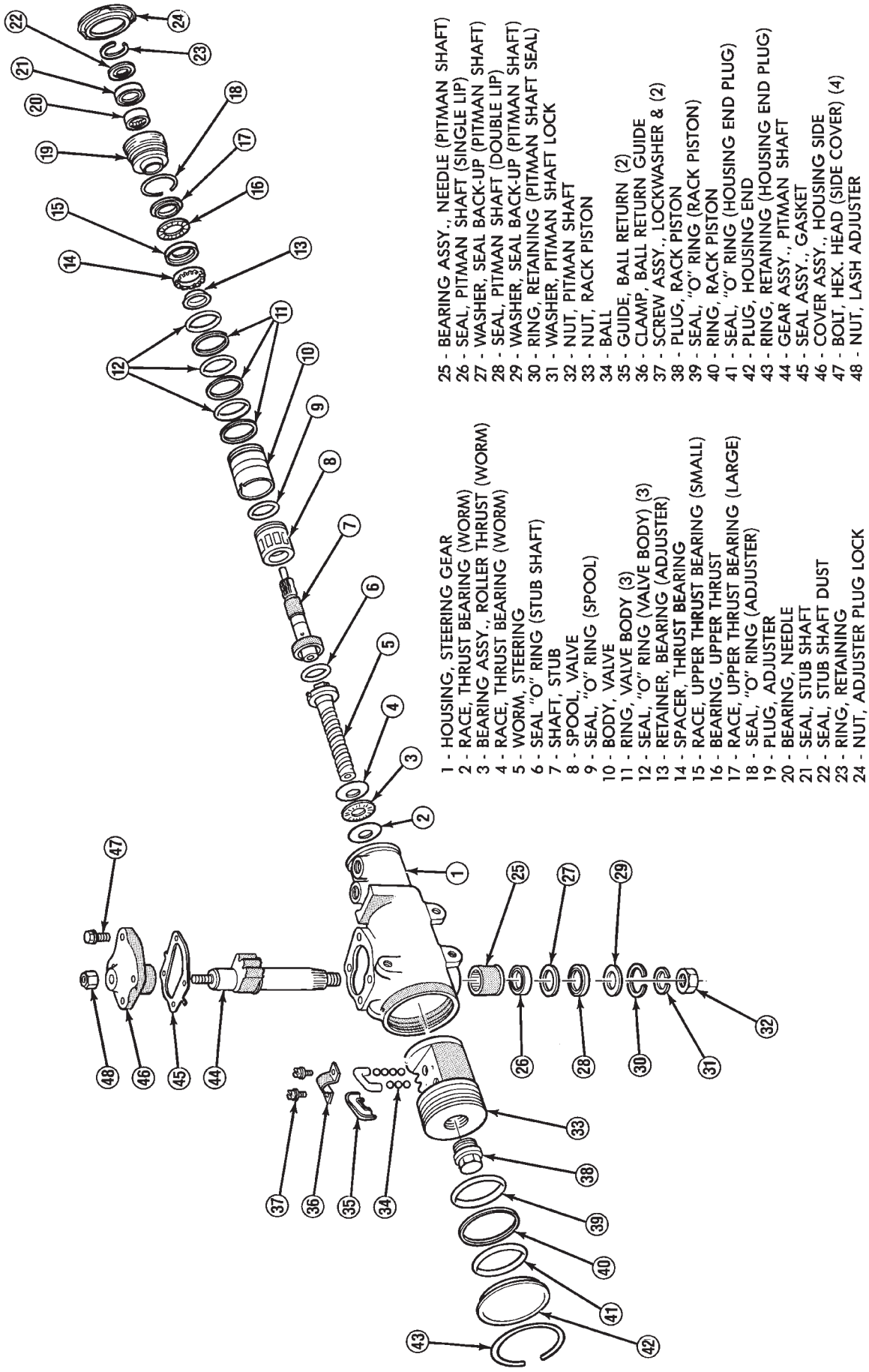

Fig. 13 Checking Over-center Rotation Torque



- 1 - HOUSING, STEERING GEAR
- 2 - RACE, THRUST BEARING (WORM)
- 3 - BEARING ASSY., ROLLER THRUST (WORM)
- 4 - RACE, THRUST BEARING (WORM)
- 5 - WORM, STEERING
- 6 - SEAL "O" RING (STUB SHAFT)
- 7 - SHAFT, STUB
- 8 - SPOOL, VALVE
- 9 - SEAL, "O" RING (SPOOL)
- 10 - BODY, VALVE
- 11 - RING, VALVE BODY (3)
- 12 - SEAL, "O" RING (VALVE BODY) (3)
- 13 - RETAINER, BEARING (ADJUSTER)
- 14 - SPACER, THRUST BEARING
- 15 - RACE, UPPER THRUST BEARING (SMALL)
- 16 - BEARING, UPPER THRUST
- 17 - RACE, UPPER THRUST BEARING (LARGE)
- 18 - SEAL, "O" RING (ADJUSTER)
- 19 - PLUG, ADJUSTER
- 20 - BEARING, NEEDLE
- 21 - SEAL, STUB SHAFT
- 22 - SEAL, STUB SHAFT DUST
- 23 - RING, RETAINING
- 24 - NUT, ADJUSTER PLUG LOCK
- 25 - BEARING ASSY., NEEDLE (PITMAN SHAFT)
- 26 - SEAL, PITMAN SHAFT (SINGLE LIP)
- 27 - WASHER, SEAL BACK-UP (PITMAN SHAFT)
- 28 - SEAL, PITMAN SHAFT (DOUBLE LIP)
- 29 - WASHER, SEAL BACK-UP (PITMAN SHAFT)
- 30 - RING, RETAINING (PITMAN SHAFT SEAL)
- 31 - WASHER, PITMAN SHAFT LOCK
- 32 - NUT, PITMAN SHAFT
- 33 - NUT, RACK PISTON
- 34 - BALL
- 35 - GUIDE, BALL RETURN (2)
- 36 - CLAMP, BALL RETURN GUIDE
- 37 - SCREW ASSY., LOCKWASHER & (2)
- 38 - PLUG, RACK PISTON
- 39 - SEAL, "O" RING (RACK PISTON)
- 40 - RING, RACK PISTON
- 41 - SEAL, "O" RING (HOUSING END PLUG)
- 42 - PLUG, HOUSING END
- 43 - RING, RETAINING (HOUSING END PLUG)
- 44 - GEAR ASSY., PITMAN SHAFT
- 45 - SEAL ASSY., GASKET
- 46 - COVER ASSY., HOUSING SIDE
- 47 - BOLT, HEX. HEAD (SIDE COVER) (4)
- 48 - NUT, LASH ADJUSTER

J9219-64

Fig. 14 Power Steering Gear

PITMAN SHAFT AND SIDE COVER REPLACEMENT

REMOVE

- (1) Remove steering gear from vehicle. Refer to Power Steering Gear Replacement in this section.
- (2) Remove pitman arm from steering gear. Refer to Pitman Arm Removal in the Steering Linkage section.
- (3) Rotate stub shaft back and forth to drain power steering fluid.

DISASSEMBLE

- Clean exposed end of pitman shaft and housing.
 - Clean pitman shaft spline with a wire brush.
- (1) Remove preload adjuster nut.
 - (2) Rotate stub shaft with socket to center gear. Remove side cover bolts.
 - (3) Remove side cover, gasket and pitman shaft as an assembly.
 - (4) Remove pitman shaft from the side cover (Fig. 15).

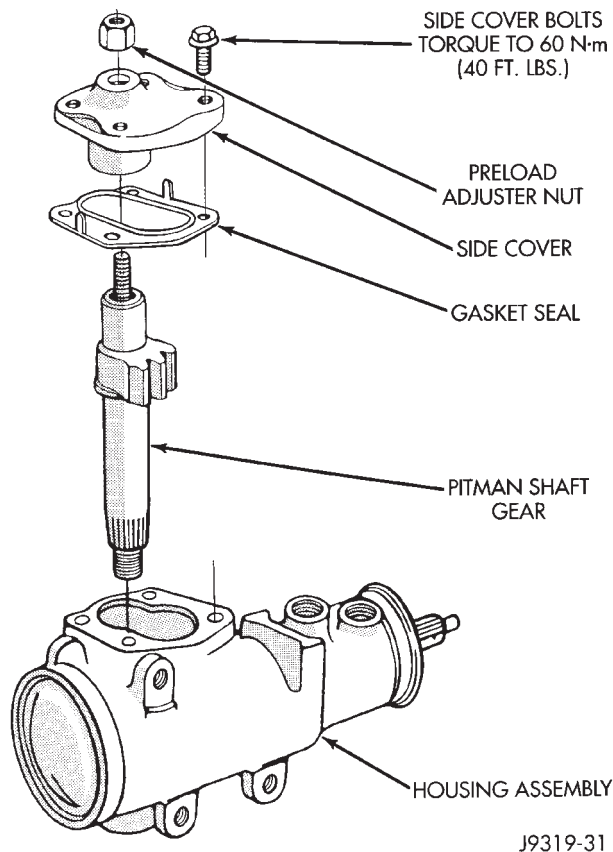

Fig. 15 Side Cover and Pitman Shaft

ASSEMBLE

- (1) Install pitman shaft to side cover by screwing shaft in until it fully seats to side cover.
- (2) Install preload adjuster nut. **Do not tighten nut until after pitman shaft adjustment has been made.**

- (3) Install gasket to side cover and bend tabs around edges of side cover.

- (4) Install pitman shaft assembly and side cover to housing.

- (5) Install side cover bolts and tighten to 60 N·m (44 ft. lbs.).

- (6) Adjust pitman shaft, refer to Over-Center Adjustment.

INSTALL

- (1) Install steering gear. Refer to Power Steering Gear Replacement in this section.

- (2) Install pitman arm onto steering gear. Refer to Steering Linkage in this Group.

HOUSING END PLUG

REMOVE

- (1) Remove steering gear from vehicle. Refer to Power Steering Gear Replacement in this section.
- (2) Remove pitman arm from steering gear. Refer to Steering Linkage in this Group.
- (3) Rotate stub shaft back and forth to drain power steering fluid.

DISASSEMBLE

- Rotate stub shaft back and forth to drain fluid
- (1) Rotate retaining ring until one end is under the hole in the housing. Unseat and force ring from groove (Fig. 16).

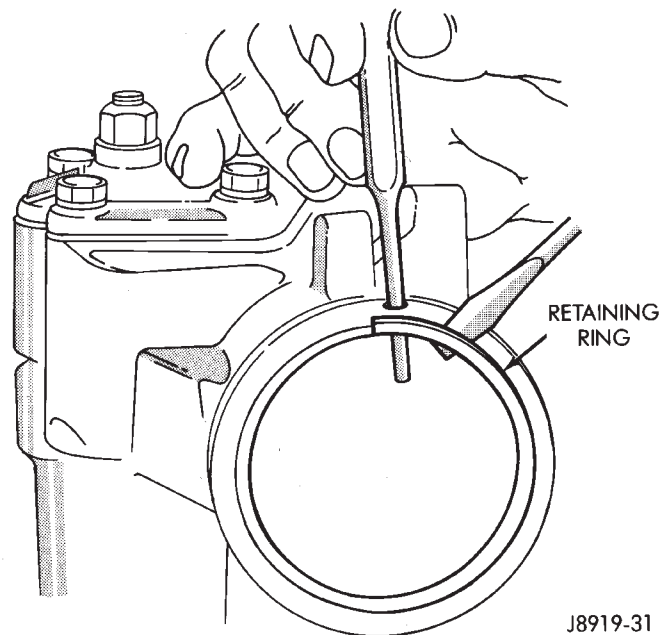

Fig. 16 End Plug Retaining Ring

- (2) Rotate stub shaft slowly COUNTER-CLOCKWISE to remove end plug out from housing (Fig. 17).

CAUTION: Do not turn stub shaft any farther than necessary. The recirculating balls will drop out of the rack piston circuit and fall inside the rack piston chamber.

(3) Remove O-ring seal (Fig. 17).

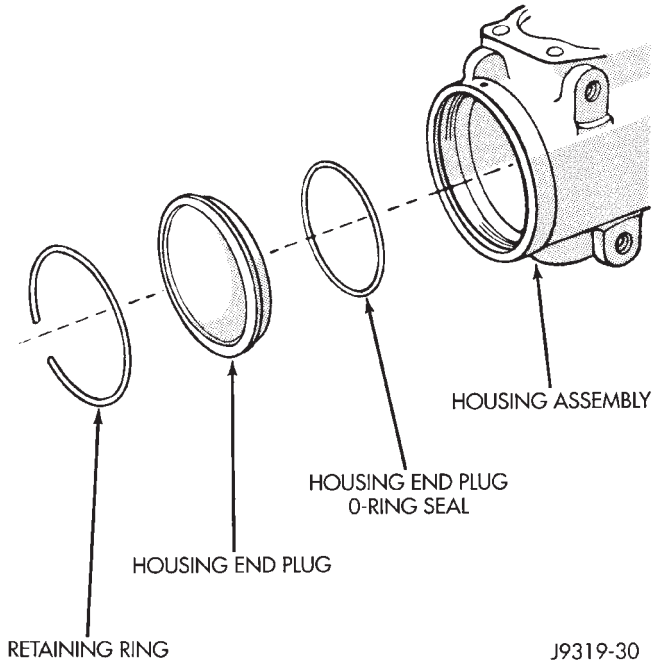

Fig. 17 End Plug Components

ASSEMBLE

- Lubricate O-ring seal with power steering fluid
- (1) Install O-ring into housing.
- (2) Install plug, tap lightly with a plastic mallet to seat it.
- (3) Install retaining ring with open end 25 mm (1 inch) from access hole (Fig. 18).

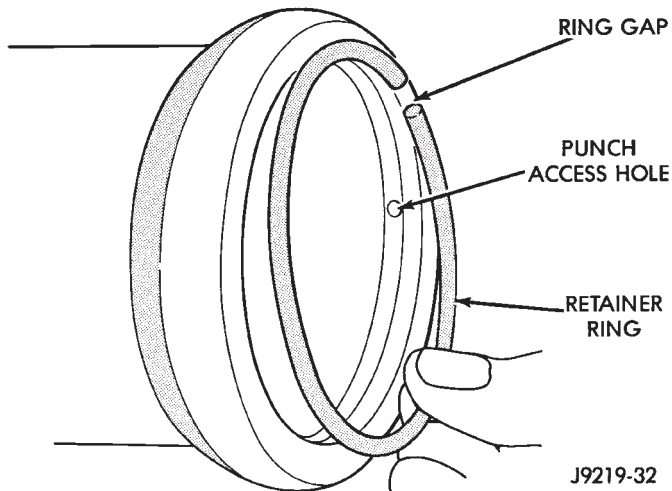

Fig. 18 Installing The Retaining Ring

INSTALL

- (1) Install steering gear. Refer to Power Steering Gear Replacement in this section.

- (2) Install pitman arm onto steering gear. Refer to Steering Linkage in this Group.

ADJUSTER PLUG ASSEMBLY REPLACEMENT

REMOVE

- (1) Remove steering gear from vehicle. Refer to Power Steering Gear Replacement in this section.

DISASSEMBLE

- (1) Remove adjuster plug lock nut from housing.
- (2) Remove adjuster plug from housing with Spanner Wrench C-4381 (Fig. 19).

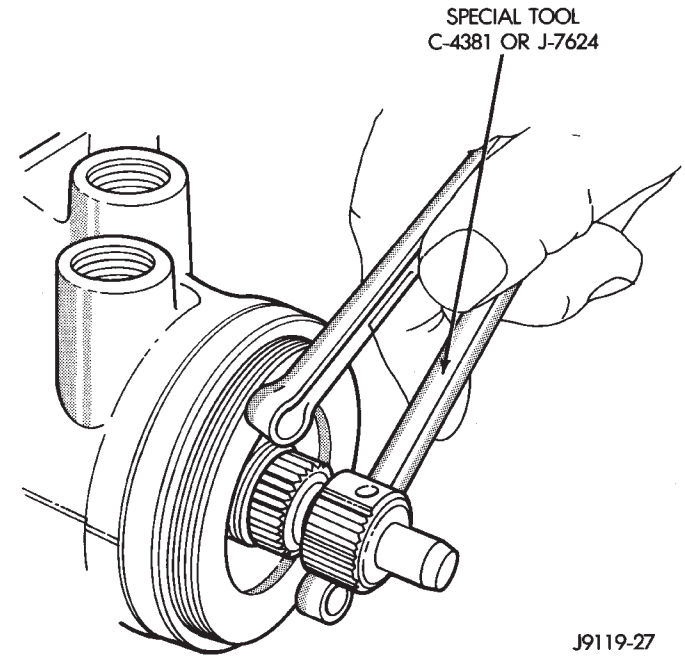

Fig. 19 Remove/Install Adjustment Plug

- (3) Remove thrust washer bearing retainer from adjuster plug with screwdriver (Fig. 20).

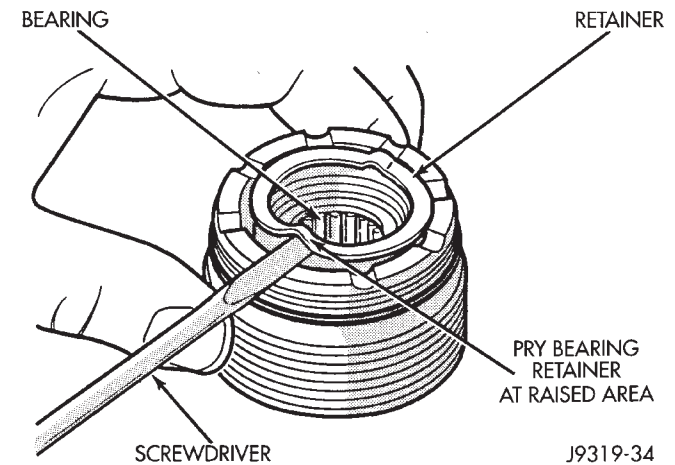

Fig. 20 Remove Retainer

(4) Remove bearing spacer, races and thrust bearing (Fig. 21).

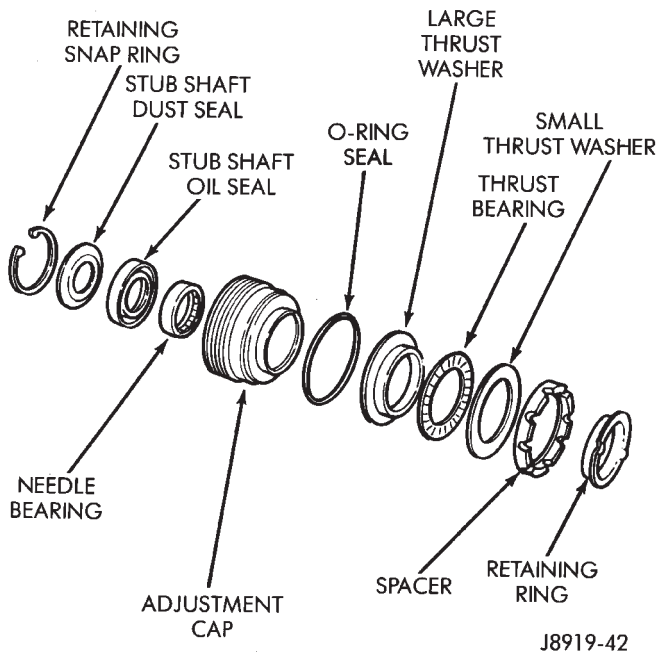

Fig. 21 Adjustment Plug Components

(5) Remove O-ring seal.
 (6) Remove retaining snap ring.
 (7) Remove needle bearing, dust seal and lip seal with tool C-4177 and handle C-4171 (Fig. 22).

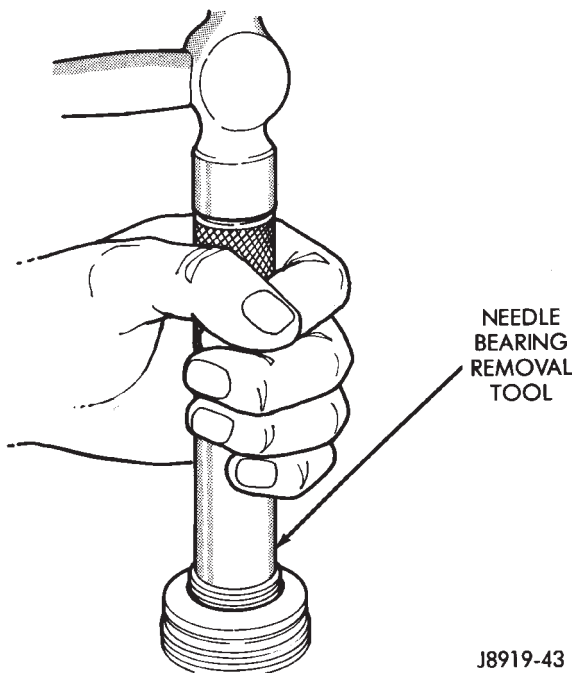

Fig. 22 Needle Bearing Removal

ASSEMBLE

CAUTION: Needle bearing must be installed with identification on bearing facing tool to prevent damage to bearing.

(1) Install needle bearing into adjuster plug with tool C-4177 and handle C-4171.

(2) Apply white petroleum grease on lip seal. Install lip seal into adjuster plug with tool C-4177 and handle C-4171.

(3) Apply white petroleum grease to dust seal cavity and install dust seal into adjuster plug with tool C-4177 and handle C-4171.

(4) Install retainer snap ring.

(5) Install O-ring seal to adjuster plug.

(6) Install large bearing race, thrust bearing, small bearing race and bearing spacer to adjuster plug.

(7) Install thrust washer bearing retainer to adjuster plug (Fig. 23).

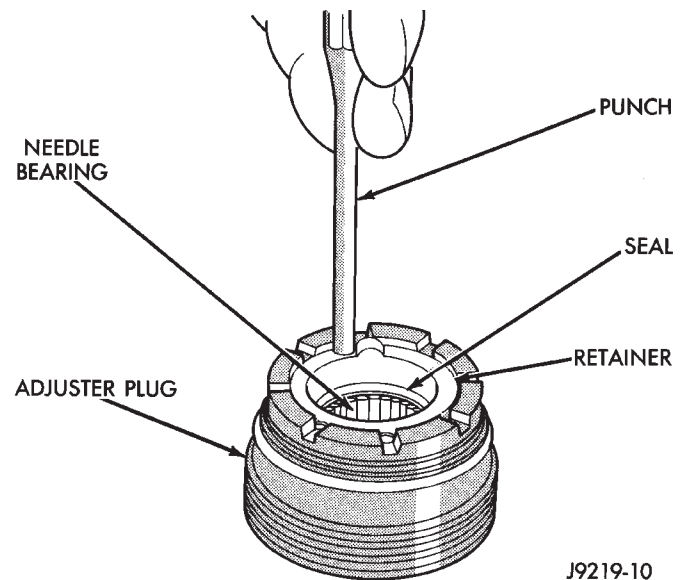

Fig. 23 Install Retainer

CAUTION: When installing adjuster plug, care should be taken NOT to cut the seals.

(8) Install adjuster plug into housing with Spanner Wrench C-4381.

(9) Adjust bearing preload, refer to Thrust Bearing Preload Adjustment.

(10) Install adjuster plug lock nut, and using a punch (drift) in a notch, tighten securely (Fig. 24). **Hold adjuster plug to maintain alignment of the marks.**

(11) Adjust pitman shaft. Refer to Over-Center Adjustment.

INSTALL

(1) Install steering gear. Refer to Power Steering Gear Replacement in this section.

VALVE REPLACEMENT

REMOVE

(1) Remove steering gear from vehicle. Refer to Power Steering Gear Replacement in this section.

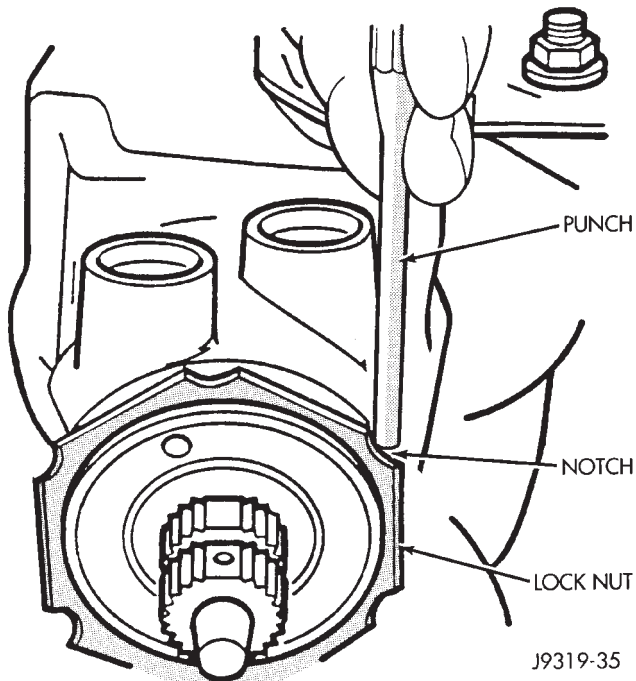

Fig. 24 Tighten Lock Nut

DISASSEMBLE

- (1) Remove adjuster plug, refer to Adjuster Plug Assembly Replacement.
- (2) Remove stub shaft and valve assembly (Fig. 25).

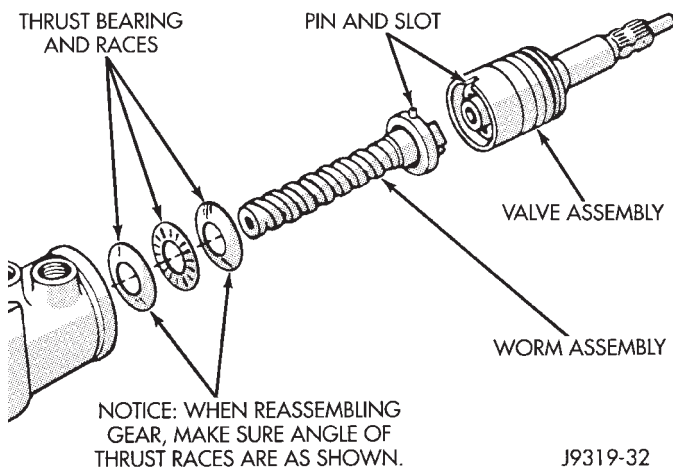

Fig. 25 Bearing, Worm and Valve Assembly

- (3) Remove stub shaft from valve assembly, if necessary.
 - Tap stub shaft lightly on a block of wood to loosen shaft cap
 - Pull cap and valve body and disengage stub shaft pin from hole in valve body (Fig. 26).
- (4) Remove valve assembly if necessary.
- Remove valve spool by pulling and rotating from valve body (Fig. 27).
- Remove valve spool O-ring seal

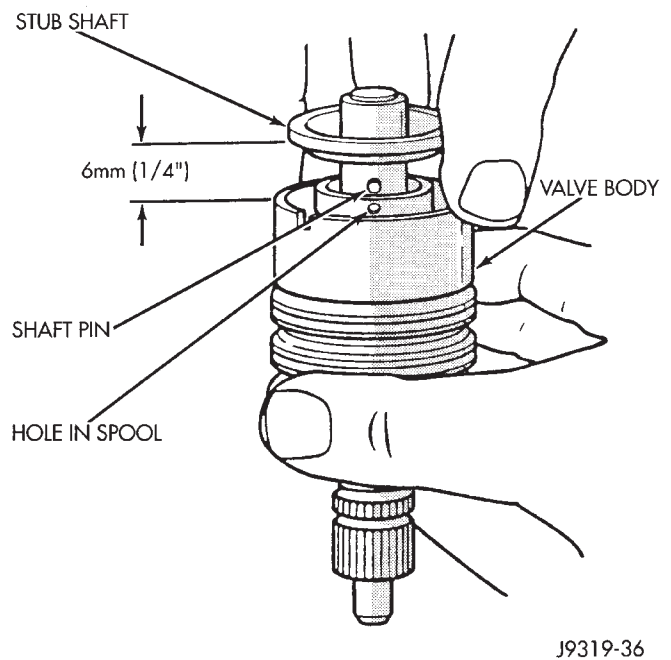

Fig. 26 Remove and Install Stub Shaft

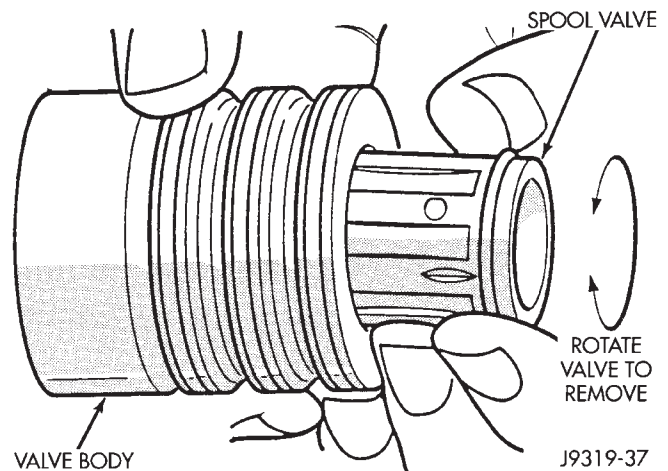
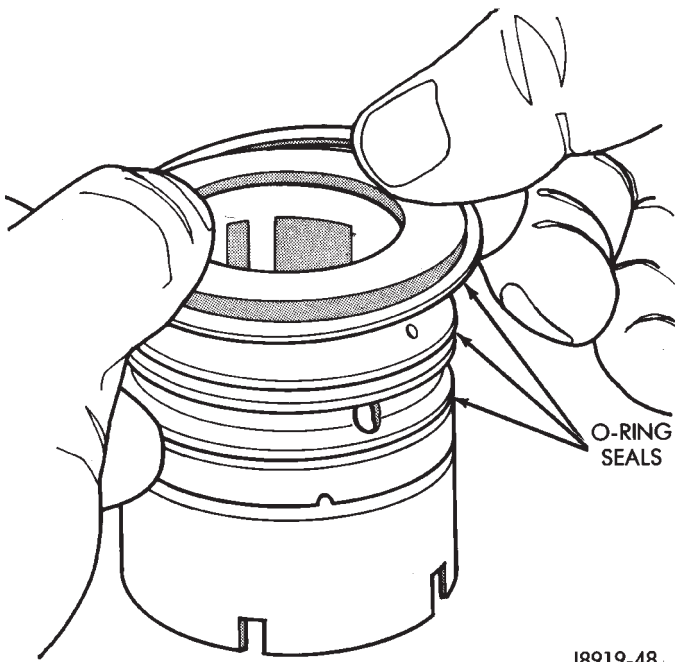

Fig. 27 Remove and Install Spool

- Remove valve body teflon rings and O-ring seals (Fig. 28).

ASSEMBLE

- (1) Install valve spool O-ring seal to valve spool.
- (2) Lubricate valve spool and O-ring seal with power steering fluid.
- (3) Install valve spool to valve body by pushing and rotating. Hole in valve spool for stub pin must be accessible from opposite end of valve body.
- (4) Assemble stub shaft to valve spool, if necessary and insert pin (Fig. 29).
 - Notch in stub shaft cap **MUST** fully engage valve body pin and seat against valve body shoulder.
- (5) Install O-ring seals and teflon rings to valve body.



J8919-48

Fig. 28 Remove and Install Valve Seals

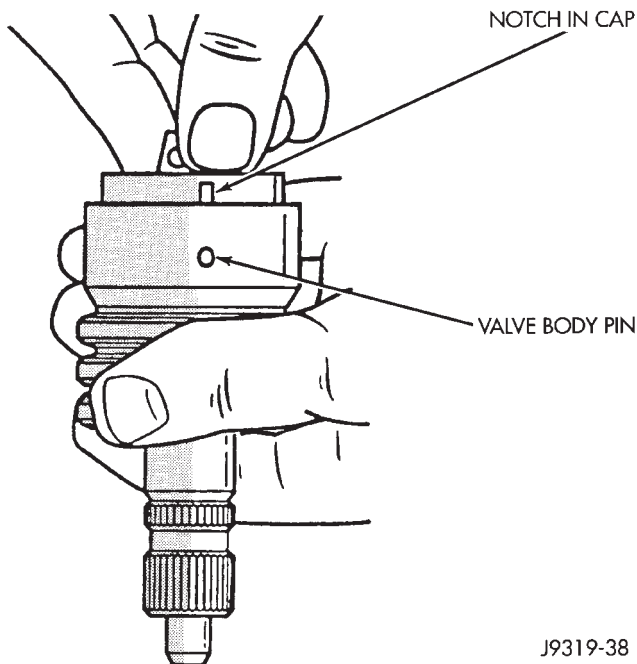

J9319-38

Fig. 29 Stub Shaft Installation

(6) Lubricate O-ring seals and teflon rings with power steering fluid.

(7) Install stub shaft and valve assembly to worm shaft, fitting on worm shaft to slot in the valve assembly.

(8) Adjust Thrust Bearing Preload Adjustment and Over-Center Adjustment. Refer to Steering Gear Adjustments in this section.

INSTALL

(1) Install steering gear. Refer to Power Steering Gear Replacement in this section.

RACK PISTON AND WORM SHAFT REPLACEMENT

REMOVE

(1) Remove steering gear from vehicle. Refer to Power Steering Gear Replacement in this section.

DISASSEMBLE

(1) Remove pitman shaft and side cover. Refer to Side Cover and Pitman Shaft Replacement in this section.

(2) Remove housing plug end. Refer to Housing End Plug Replacement in this section.

(3) Turn stub shaft **COUNTERCLOCKWISE** until the rack piston begins to come out of the housing.

(4) Remove rack piston plug (Fig. 30).

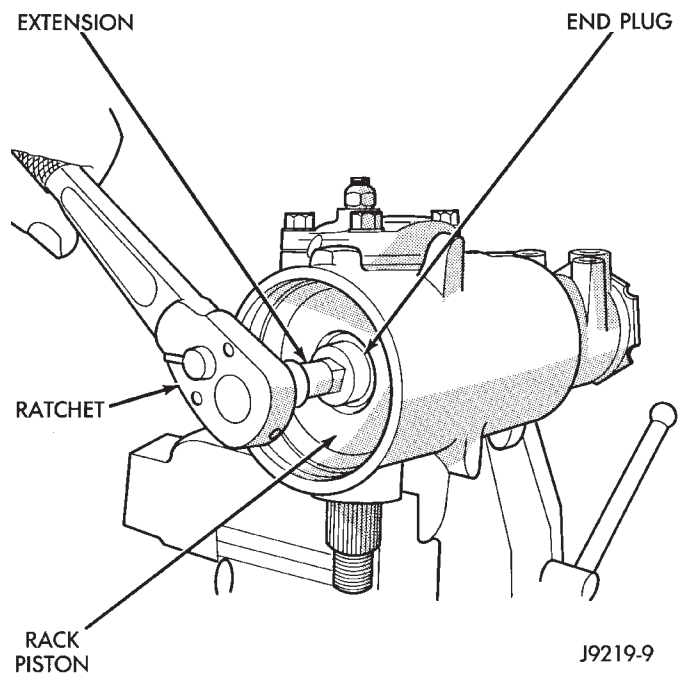

J9219-9

Fig. 30 Remove and Install Rack Piston End Plug

(5) Insert Arbor C-4175 into bore of rack piston (Fig. 31). Hold tool tightly against worm shaft while turning the stub shaft **COUNTERCLOCKWISE**.

• The rack piston will be forced onto the tool and hold the rack piston balls in place.

(6) Remove the rack piston, rack balls, and tool together from housing.

(7) Remove valve. Refer to Valve Replacement in this section.

(8) Remove worm shaft.

(9) Remove thrust bearing and races.

(10) Remove tool from rack piston.

(11) Remove rack piston balls.

(12) Remove screws, clamp and ball guide.

(13) Remove teflon ring and O-ring seal (Fig. 32).

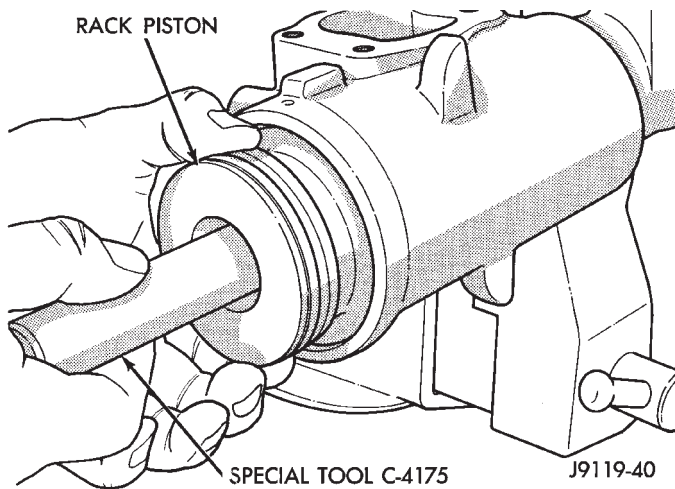

Fig. 31 Remove and Install Rack Piston

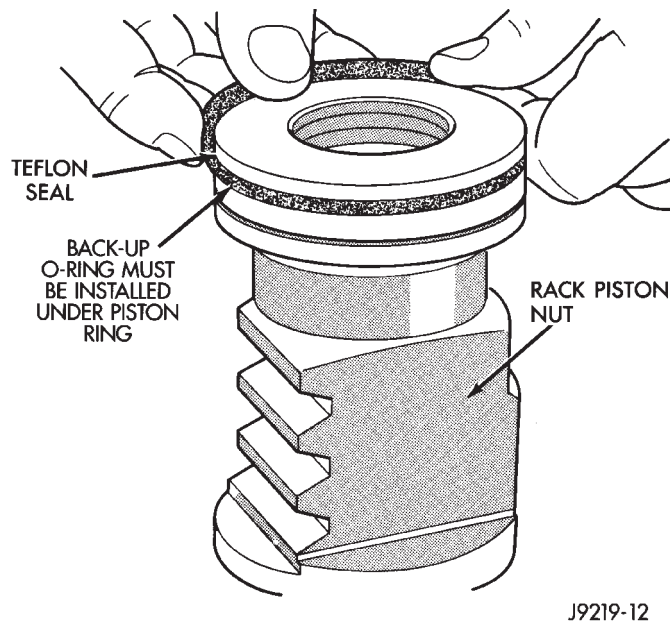

Fig. 32 Remove and Install Seal on Rack Piston

CLEAN AND INSPECTION

- (1) Wash all components in clean solvent and dry with compressed air.
- (2) Check for scores, nicks or burrs on the rack piston finished surface. Slight wear is normal on the worm gear surfaces.

ASSEMBLE

- (1) Install O-ring seal and teflon ring and lubricate with power steering fluid.
- (2) Install worm shaft to rack piston outside of housing. Fully seat worm shaft to rack piston and align worm shaft spiral groove with rack piston ball guide hole (Fig. 33).

WARNING: MAKE SURE ALL RACK PISTON BALLS ARE REINSTALLED IN THE RACK PISTON. IMPROPER INSTALLATION MAY RESULT IN PERSONAL INJURY.

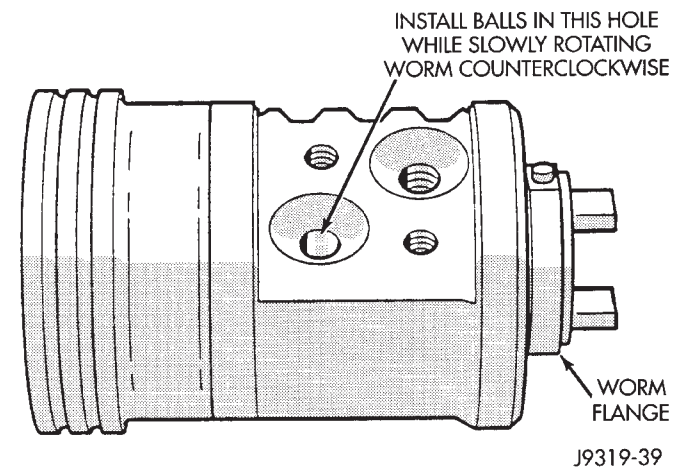

Fig. 33 Installing Balls in Rack Piston

There are 24 balls in the rack piston circuit, 12 are black and 12 are silver (Chrome). The black rack piston balls are smaller than the silver balls. **THE BLACK AND SILVER BALLS MUST BE INSTALLED ALTERNATELY INTO THE RACK PISTON AND BALL GUIDE.** This procedure will maintain worm shaft preload.

(3) Lubricate and install rack piston balls through return guide hole while turning wormshaft COUNTERCLOCKWISE.

(4) Install remaining balls to guide using grease or petroleum jelly at each end to hold in place (Fig. 34).

(5) Install guide onto rack piston and return with

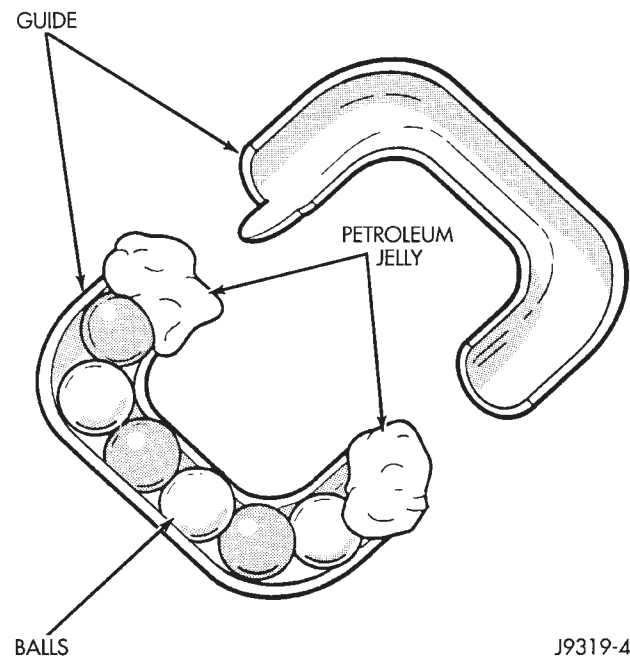

Fig. 34 Balls in the Return Guide

clamp and screws. Tighten screws to 58 N·m (43 in. lbs.) torque.

(6) Insert Arbor C-4175 into bore of rack piston. Hold tool tightly against worm shaft while turning

the stub shaft COUNTERCLOCKWISE.

- The rack piston will be forced onto the tool and hold the rack piston balls in place.

(7) Install the races and thrust bearing to worm shaft (Fig. 35).

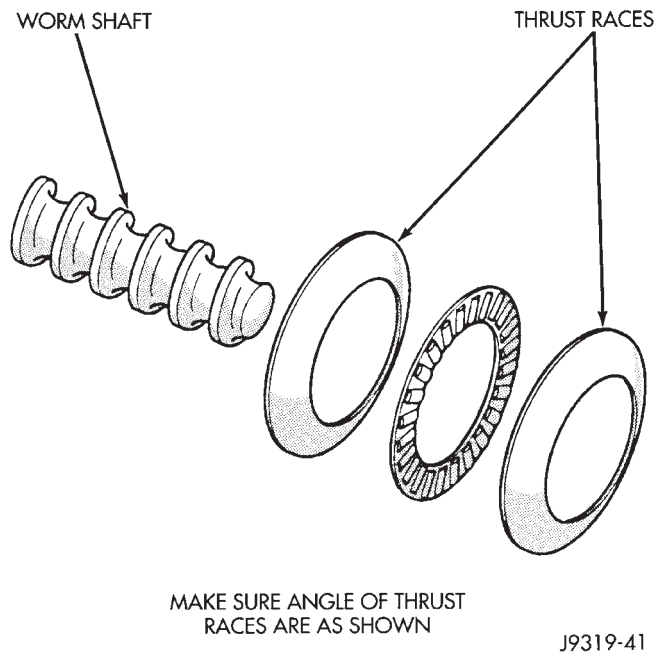

Fig. 35 Worm Shaft and Bearing

- (8) Install worm shaft to housing.
- (9) Install valve. Refer to Valve Replacement in this section.
- (10) Install rack piston to worm shaft from tool, compress seals.
- Hold Arbor tightly against worm shaft and turn stub shaft CLOCKWISE until rack piston is seated on worm shaft.

WARNING: MAKE SURE ALL RACK PISTON BALLS ARE REINSTALLED IN THE RACK PISTON. IMPROPER INSTALLATION MAY RESULT IN PERSONAL INJURY.

(11) Install rack piston plug and tighten to 150 N·m (111 ft. lbs.) torque.

(12) Install housing end plug. Refer to Housing End Plug Replacement in this section.

(13) Install pitman shaft and side cover. Refer to Side Cover and Pitman Shaft Replacement in this section.

(14) Adjust steering gear. Refer to Steering Gear Adjustments in this section.

INSTALL

(1) Install steering gear. Refer to Power Steering Gear Replacement in this section.

PITMAN SHAFT SEALS AND BEARING REPLACEMENT

REMOVE

(1) Remove steering gear from vehicle. Refer to Power Steering Gear Replacement in this section.

DISASSEMBLE

(1) Remove pitman arm from gear. Refer to Pitman Arm Removal in Steering Linkage.

(2) Clean exposed end of pitman shaft and housing. Use a wire brush to clean the shaft splines.

(3) Remove retaining ring with snap ring pliers (Fig. 36).

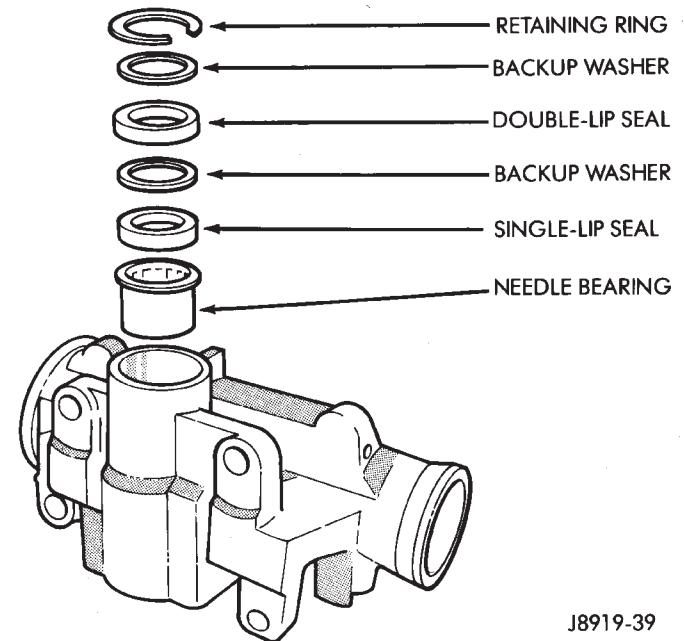

Fig. 36 Pitman Shaft Seals

CAUTION: Use care not to score the housing bore when prying out seals and washers.

(4) Remove backup washer and double lip seal with screwdriver.

(5) Remove backup washer and single lip seal with screwdriver.

(6) Inspect the housing for burrs and remove if necessary.

(7) Remove needle bearing from side cover area of housing using tool C-4177 and handle C-4171 (Fig. 37).

ASSEMBLE

(1) Install needle bearing into housing using tool C-4178 and handle C-4171 (Fig. 38).

(2) Install single lip seal with tool C-4178 and handle C-4171 or a suitable size socket (Fig. 39).

(3) Coat the double lip seal and washer with grease.

(4) Install the backup washer.

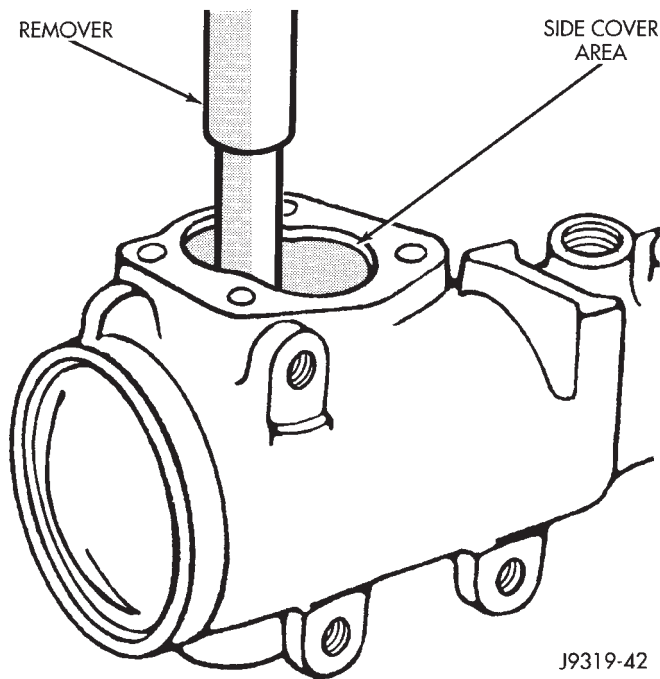

Fig. 37 Needle Bearing Removal

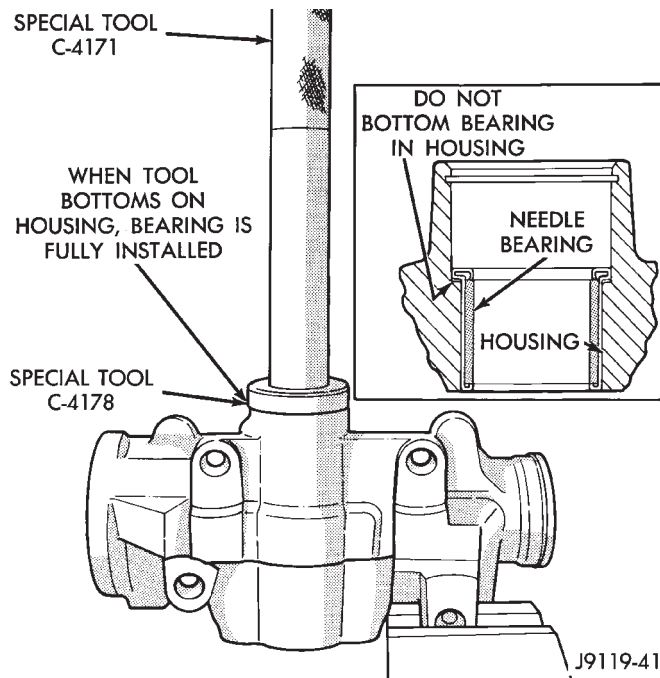

Fig. 38 Pitman Shaft Bearing Installation

- (5) Install the double lip seal.
- (6) Install the backup washer.
- (7) Install the retainer ring with snap ring pliers.
- (8) Install the pitman shaft and side cover. Refer to Side Cover and Pitman Shaft Replacement in this section.

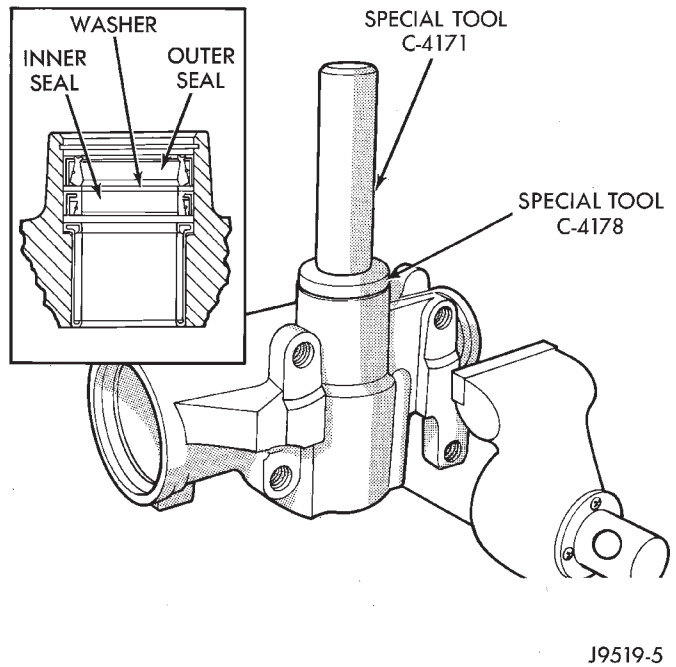

Fig. 39 Pitman Shaft Seal Installation

INSTALL

- (1) Install steering gear. Refer to Power Steering Gear Replacement in this section.

CHECK VALVE REPLACEMENT

REMOVE

- (1) Remove steering gear from vehicle. Refer to Power Steering Gear Replacement in this section.

DISASSEMBLE

CAUTION: Use care not to damage the threads of the housing when prying out check valve.

- (1) Remove valve by prying from housing with a small screwdriver.

ASSEMBLE

- (1) Install the valve into the housing with a 3/8-inch diameter piece of tubing 100 mm (4 inches) long.

INSTALL

- (1) Install steering gear. Refer to Power Steering Gear Replacement in this section.

POWER STEERING GEAR SPECIFICATIONS

Steering Gear Type Recirculating ball with hydraulic assist.

Ratio Code (Top of Gear)

BH, NZ 14:1
 BF, XS 13-16:1
 AL 12.7:1

Steering Gear Hydraulic Fluid Use Mopar Power Steering Fluid, or equivalent.

Steering Gear Lubricants Lubricate pitman shaft seals, bearings races, and rack piston recirculating balls with petroleum jelly. Lubricate all other parts with power steering fluid.

Steering Gear Adjustments:

Wormshaft Bearing Preload Torque 0.45-1.13 N·m (4 to 10 in-lbs)

Pitman Shaft Overcenter Drag Torque:

New Gear
 (less than 400 miles/640 km) 0.45-0.90 N·m (4 to 8 in-lbs) in addition to wormshaft bearing preload but not to exceed combined total of 2 N·m (18 in-lbs).

Used Gear
 (over 400 miles/640 km) 0.5-0.6 N·m (4 to 5 in-lbs) in addition to wormshaft bearing preload but not to exceed combined total of 2 N·m (18 in-lbs).

Caution: Gears must be adjusted exactly as outlined in Steering Gear Adjustments-On Bench. Failure to adhere to the recommended procedures may result in gear damage or improper steering response.

MANUAL STEERING GEAR

INDEX

	page		page
Diagnosis	37	Gear Disassembly	39
Gear Adjustments in Vehicle	39	Information	37
Gear Adjustments on Bench	44	Intermediate (Coupler) Shaft	45
Gear Assembly	43	Pitman Shaft Seal Replacement	37
Gear Cleaning and Inspection	42	Steering Gear Replacement	45

INFORMATION

The manual steering gear installed on Jeep vehicles (Fig. 1) has a variable steering ratio.

DIAGNOSIS

PITMAN SHAFT SEAL REPLACEMENT

REMOVAL

(1) Mark pitman arm and shaft positions for reference. Remove pitman arm with Puller 7998.

(2) Remove the pitman shaft seal with a small blade screw driver.

INSPECTION

(1) Inspect the condition of the steering gear lubricant. If contaminated (contains metal particles), remove and overhaul the steering gear.

INSTALLATION

(1) Lubricate the new seal with chassis lubricant.

CAUTION: A protective wrap must be used on the shaft threads/splines during seal installation. If the shaft seals are installed over exposed shaft, the seal lips could be cut or distorted. This can result in leakage after installation.

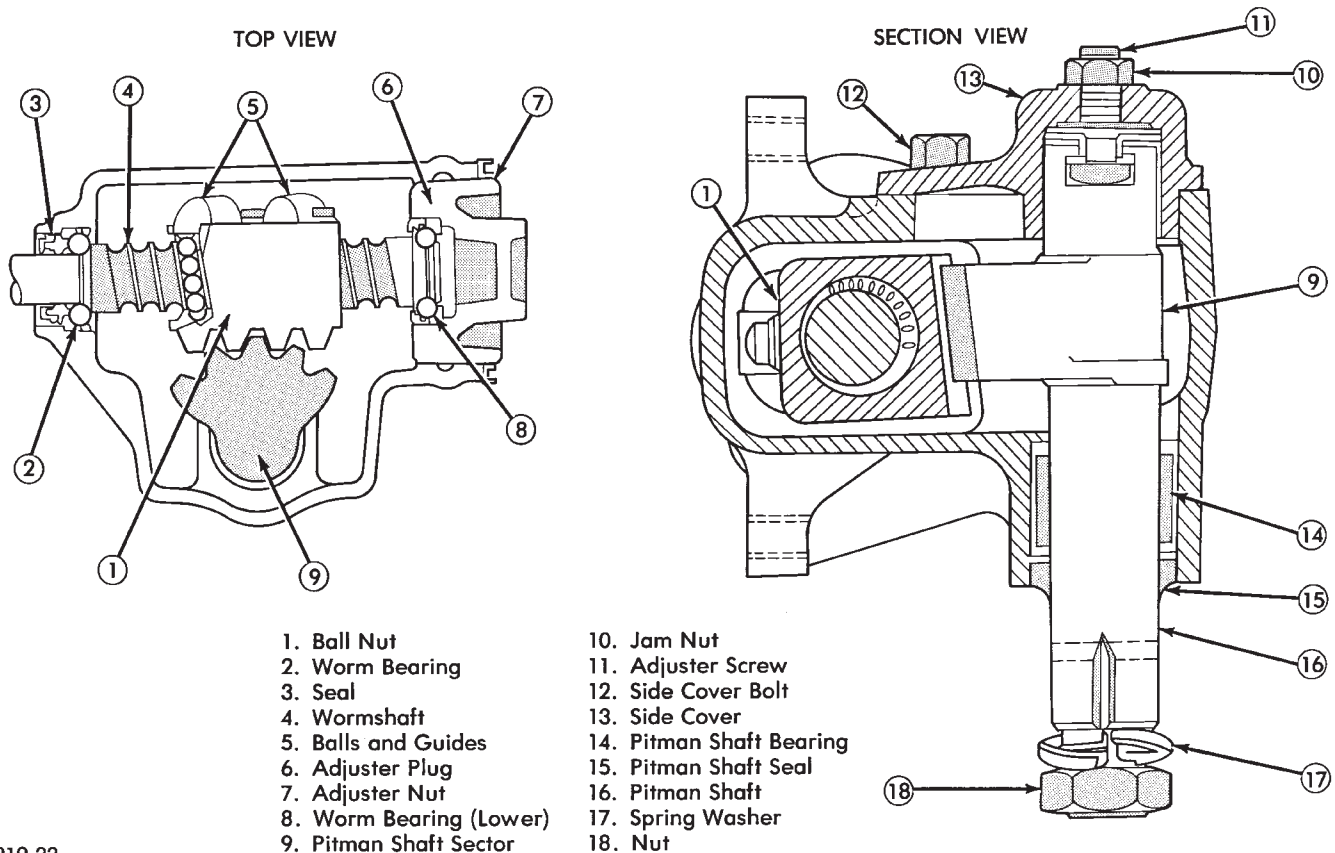

J9219-33

Fig. 1 Manual Steering Gear

MANUAL STEERING SYSTEM DIAGNOSIS

PROBLEM	POSSIBLE CAUSE	CORRECTION
Rattle Or Chuckle In The Steering Gear	<ol style="list-style-type: none"> 1. Insufficient or improper lubricant in the steering gear. 2. Pitman arm loose on the shaft or the steering gear mounting bolts loose. 3. Loose or worn steering shaft bearing. 4. Excessive over-center lash or worm thrust bearings adjusted too loose. On turns a slight rattle may occur, due to the increased lash between ball nut and pitman shaft as gear moves off the center of "high point" position. This is normal and lash must not be reduced to eliminate this slight rattle. 	<ol style="list-style-type: none"> 1. Add lubricant as required. 2. Tighten to specified torque. 3. Replace the steering shaft bearing. 4. Adjust the steering gear to specified preloads.
Poor Return Of The Steering Wheel	<ol style="list-style-type: none"> 1. Steering column misaligned. 2. Insufficient or improper lubricant in the steering gear or front suspension. 3. Steering gear adjusted too tight. 4. Front wheel alignment incorrect (Caster). 	<ol style="list-style-type: none"> 1. Align the column. 2. Lubricate as specified. 3. Adjust over-center and thrust bearing preload to specifications. 4. Adjust to specifications.
Excessive Play Or Looseness In The Steering System	<ol style="list-style-type: none"> 1. Front wheel bearings loosely adjusted. 2. Steering system out of alignment. 3. Worn upper ball joints. 4. Steering wheel loose on the shaft, loose pitman arm, tie rods, steering arms or steering linkage ball nuts. 5. Tires badly worn, edge of tires rounded off. 6. Excessive over-center lash. 7. Worm thrust bearings loosely adjusted. 	<ol style="list-style-type: none"> 1. Adjust bearings or replace with new parts as necessary. 2. Align caster, camber, and toe-in. 3. Check and replace ball joints if necessary. 4. Tighten to specification, replace if worn or damaged. 5. Install new tires, and check alignment. 6. Adjust over-center preload to specifications. 7. Adjust the worm thrust bearing preload to specifications.
Hard Steering – Excessive Effort Required At The Steering Wheel	<ol style="list-style-type: none"> 1. Low or uneven tire pressure. 2. Insufficient or improper lubricant in the steering gear or front suspension. 3. Steering shaft flexible coupling misaligned. 4. Steering gear adjusted too tight. 5. Front wheel alignment incorrect. 	<ol style="list-style-type: none"> 1. Inflate to specified pressures. 2. Lubricate as specified. Relubricate at specified intervals. 3. Align the column and couplings. 4. Adjust over-center and thrust bearing preload to specifications. 5. Check the alignment and correct as necessary.

(2) Wrap a single layer of plastic tape around the pitman shaft threads and splines. This will protect the replacement seals during installation.

(3) Install the seal with a suitable size socket.

(4) Remove the tape from the shaft.

(5) Center the steering gear.

(6) Align and install the pitman arm.

(7) Install the washer and retaining nut on the pitman shaft. Tighten the nut to 251 N·m (185 ft. lbs.) torque.

GEAR ADJUSTMENTS IN VEHICLE

REMOVE

(1) Raise and support the vehicle.

(2) Mark the pitman shaft and pitman arm for installation reference. Remove the pitman arm from the shaft.

(3) Loosen the adjuster lock nut then back the adjuster plug off 1/4 turn.

(4) Remove the steering wheel horn pad.

(5) Turn the steering wheel in one direction until stopped by the gear. Then turn back 1/2 turn.

CAUTION: Do not turn the steering wheel hard against the internal stops when the linkage is removed. This could result in damage to the recirculating ball guides.

MEASURE

Place a low calibration (50 in. lbs.) torque wrench and socket on the steering wheel nut. Rotate the wrench and nut through a 90 degree arc (1/4 turn). This will measure the worm shaft bearing preload.

ADJUST WORMSHAFT BEARING PRELOAD TORQUE

(1) Adjust the preload by tightening the adjuster plug. The preload should be 0.6 to 1 N·m (5 to 8 in. lbs.) torque.

Steering column/shaft misalignment or damage will increase the amount of torque required to rotate the steering wheel. If the rotating torque is exceptionally high, inspect the steering column/shaft alignment. If the alignment is correct, remove the steering gear, determine the cause of the high preload torque, and repair as necessary.

(2) Tighten the adjuster locknut to 68 N·m (50 ft. lbs.) torque. Measure the preload torque. If necessary, adjust the preload torque again.

ADJUST OVERCENTER DRAG TORQUE

(1) Turn the steering wheel from one stop to the other and count the total numbers of turns. Turn the wheel back in reverse direction 1/2 the total number of turns to center the steering gear.

(2) Turn the over center adjusting screw in to remove all lash between the ball nut and pitman shaft sector teeth. Hold the adjustment screw and tighten the lock nut to 34 N·m (25 ft. lbs.) torque.

(3) Check the torque at the steering wheel by taking the highest reading as the wheel is turned through the center position.

(4) The overcenter drag torque should be 0.5 to 1 N·m (4 to 10 in. lbs.).

(5) If necessary, loosen the lock nut and adjust the over center adjuster screw to obtain the proper torque. Re-tighten the lock nut to the lock nut.

(6) After tightening the locknut, measure the overcenter drag torque again and readjust the torque, if necessary.

INSTALL

(1) Align the installation reference marks and install the pitman arm.

(2) Install and tighten the pitman shaft nut and washer to 251 N·m (185 ft. lbs.) torque.

(3) Install the horn button.

GEAR DISASSEMBLY

(1) Rotate the wormshaft from stop-to-stop and count the number of rotations. Rotate the wormshaft in the reverse direction 1/2 of the total number of rotations to center it and the ball nut.

(2) Remove the pitman shaft adjustment screw locknut. Remove the cover retaining bolts, cover, and gasket (Fig. 3).

(3) Slide the adjustment screw head (Fig. 3) out of the pitman shaft T-slot and remove it and the shim(s).

(4) Retain the shim(s) for end-play measurement during assembly.

(5) Remove the pitman shaft, the wormshaft bearing preload torque adjustment cap locknut, and the adjustment cap (Fig. 2).

(6) Remove the wormshaft and the ball nut (Fig. 2).

(7) Remove (pry) the pitman shaft and the wormshaft seals from the steering gear housing (Fig. 3).

WORMSHAFT AND BALL NUT DISASSEMBLY

(1) Remove the upper bearing from the wormshaft (Fig. 2).

CAUTION: Do not allow the ball nut to rotate freely and travel to either extreme end of the wormshaft. This could damage the tangs at the ends of the recirculating ball guides (Fig. 3).

(2) Remove the recirculating ball guide clamp retaining screws, the clamp and the guides (Fig. 2). Separate the half-guides and place the recirculating balls aside in a container.

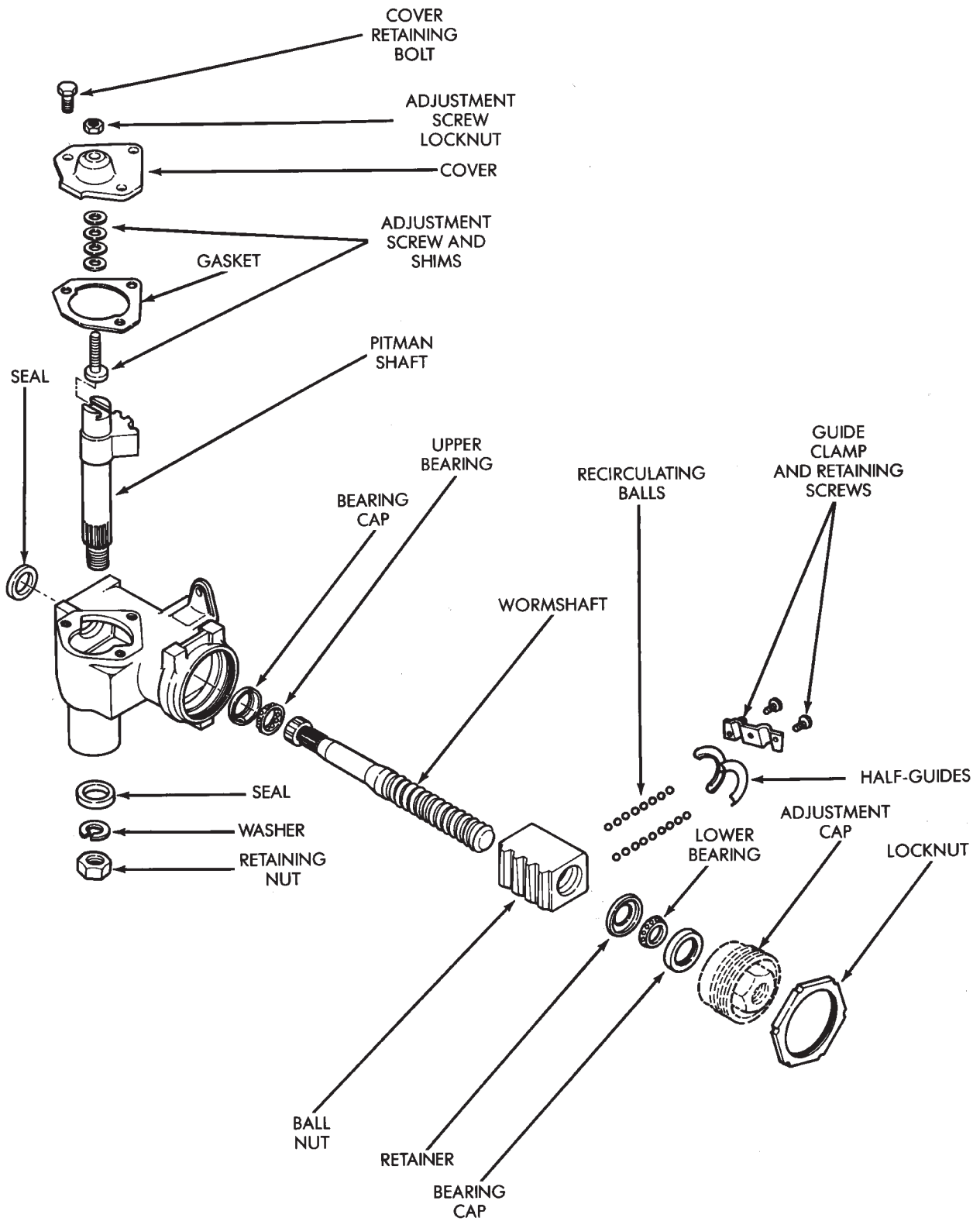

J8919-12

Fig. 2 Manual Steering Gear—Exploded View

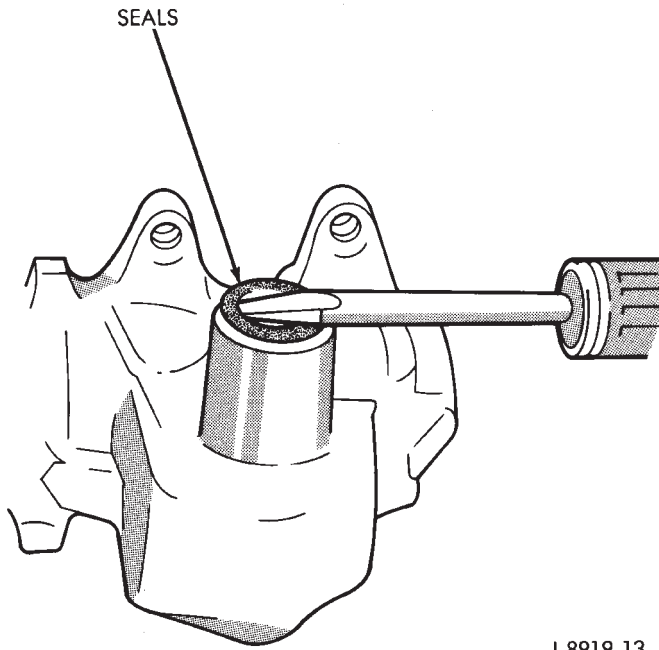

J-8919-13

Fig. 3 Shaft Seal Removal

(3) Hold the ball nut over a cloth. Remove the remaining recirculating balls by rotating the wormshaft back and forth.

There are a total of 50 recirculating balls within the ball nut and the guides (25 in each circuit).

(4) Remove the wormshaft from the ball nut (Fig. 2).

CLEANING AND INSPECTION

(1) Clean all the components in a cleaning solvent and dry them with a clean cloth and/or compressed air.

(2) Inspect each component for wear, scoring, cracks, nicks and surface pitting. Replace as necessary.

WORMSHAFT AND BALL NUT ASSEMBLY

CAUTION: The ball nut teeth are wider and deeper on one side than on the other.

(1) Position the ball nut with the recirculating ball guide holes facing upward and the ball nut teeth facing downward. Install the wormshaft in the ball nut. Rotate the shaft and thread it into the nut until an equal number of shaft threads are visible at each end of the nut (Fig. 4).

(2) Install one recirculating ball in each ball guide hole. Move the wormshaft up/down and side-to-side until the balls roll into the ball nut threads at the bottom of wormshaft and support the wormshaft.

(3) Assemble and install the ball guides in the ball nut (Fig. 5).

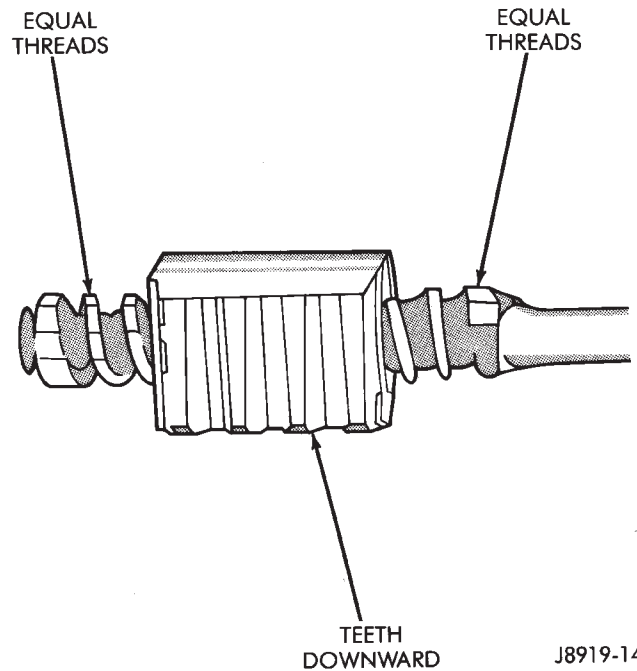

J8919-14

Fig. 4 Wormshaft & Ball Nut

(4) Divide the remaining 48 recirculating balls into two groups and install 24 balls in each ball nut circuit. Insert the balls in the ball nut circuits through the holes in the ball guides (Fig. 5).

To aid the recirculating ball installation, rotate wormshaft back and forth slightly while inserting the balls.

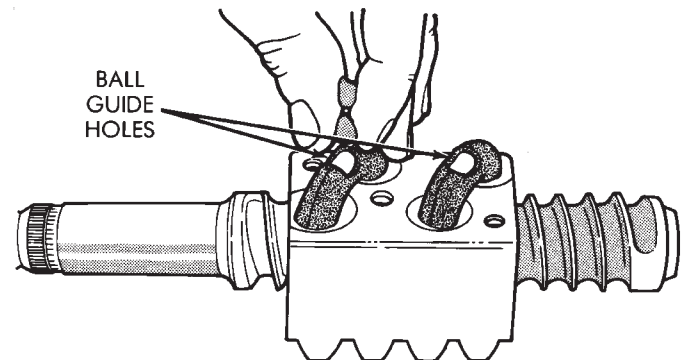

J8919-15

Fig. 5 Recirculating Ball Installation

(5) Place the ball guide clamp on the ball nut and install the clamp retaining screws. Tighten the screws to 14 N·m (10 ft. lbs.) torque.

CAUTION: To avoid damaging the tangs on the ball guide ends, do not allow the wormshaft to travel to the end of the thread in either direction.

(6) Lubricate the wormshaft threads with chassis lubricant. Rotate the shaft to move it in and out of the ball nut and distribute the lubricant.

(7) Lubricate the wormshaft upper bearing with chassis lubricant and install it on the wormshaft.

WORMSHAFT BEARING ADJUSTMENT CAP DISASSEMBLY

(1) Pry out and remove the wormshaft lower bearing retainer from the adjustment cap (Fig. 6).

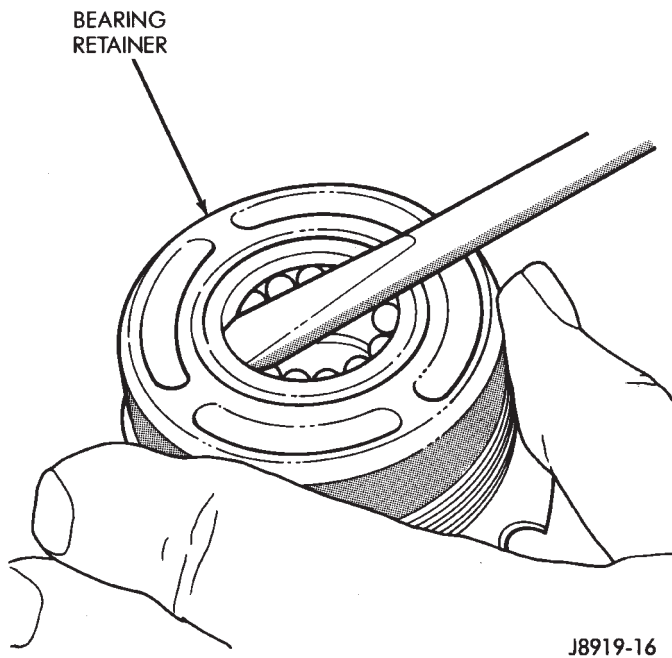

Fig. 6 Wormshaft Lower Bearing Retainer Removal

(2) Remove the wormshaft lower bearing from the adjustment cap.

CLEANING/INSPECTION

(1) Clean all the components in cleaning solvent and dry with a clean cloth only.

(2) Inspect each component for wear and damage. Replace as necessary.

WORMSHAFT BEARING ADJUSTMENT CAP ASSEMBLY

(1) Remove the lower bearing cup Remover 7837 and Slide Hammer C-637 (Fig. 7). Install a new bearing cup in the cap with a correct sized socket (Fig. 8).

(2) Lubricate the wormshaft lower bearing and place it in the bearing cup.

(3) Install the lower bearing retainer on the adjustment cap. If necessary, tap the retainer lightly with a plastic mallet to seat it.

GEAR CLEANING AND INSPECTION

(1) Clean the housing and the pitman shaft with cleaning solvent and dry them with a clean cloth and/or compressed air.

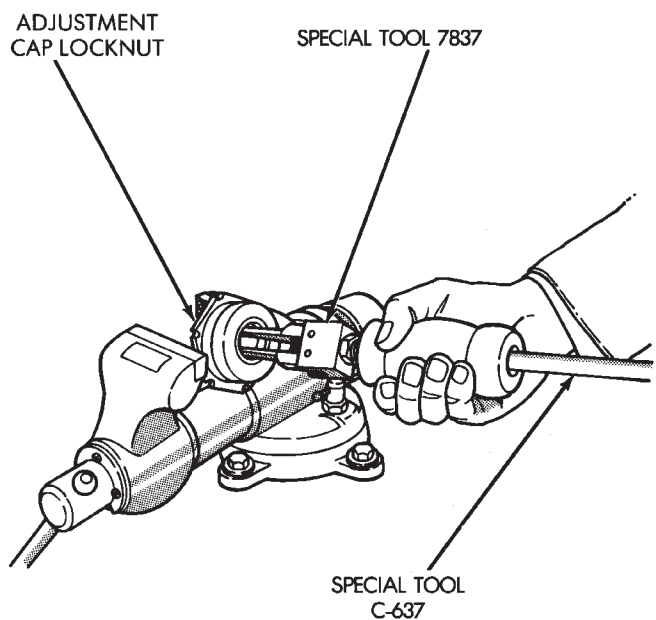

Fig. 7 Bearing Cup Removal

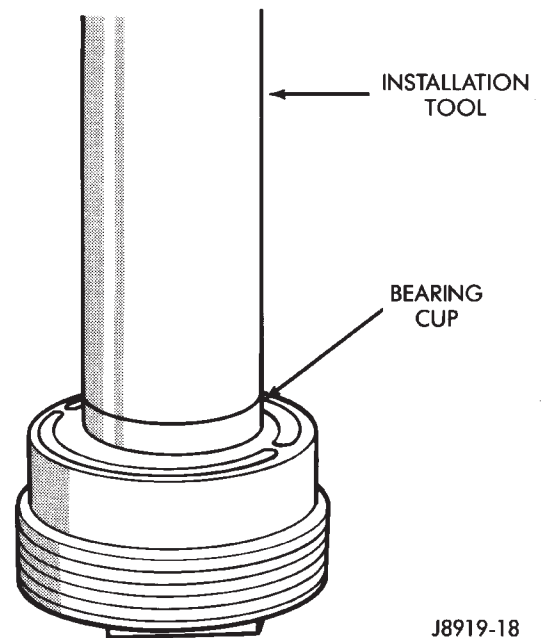

Fig. 8 Bearing Cup Installation

(2) Inspect the housing for cracks, porosity, damaged threads and scoring/distortion of the gasket surface area. Repair or replace as necessary.

(3) Inspect the pitman shaft contact surface and the teeth for wear, pitting, and other damage. Replace as necessary.

(4) Insert the pitman shaft in the steering gear housing shaft bore and inspect for excessive shaft or housing shaft bore wear. The shaft should have a smooth, bind-free fit with no visible side play when installed in the shaft bore.

(5) If the shaft fit is loose but it is not visibly worn, trial fit a replacement pitman shaft in the housing shaft bore. If the replacement shaft also has a loose fit, replace the housing. However, if the replacement pitman fits properly, replace the original pitman shaft.

(6) Measure the pitman shaft adjustment screw fit and end-play in the T-slot (Fig. 9). When installed, the adjustment screw must rotate freely and not bind in any position. Measure the end-play by inserting a feeler gauge between the screw head and the T-slot surface. **The end-play must not exceed 0.05 mm (0.002 in).** If end-play exceeds the specified limit, install a replacement shim to reduce the end-play.

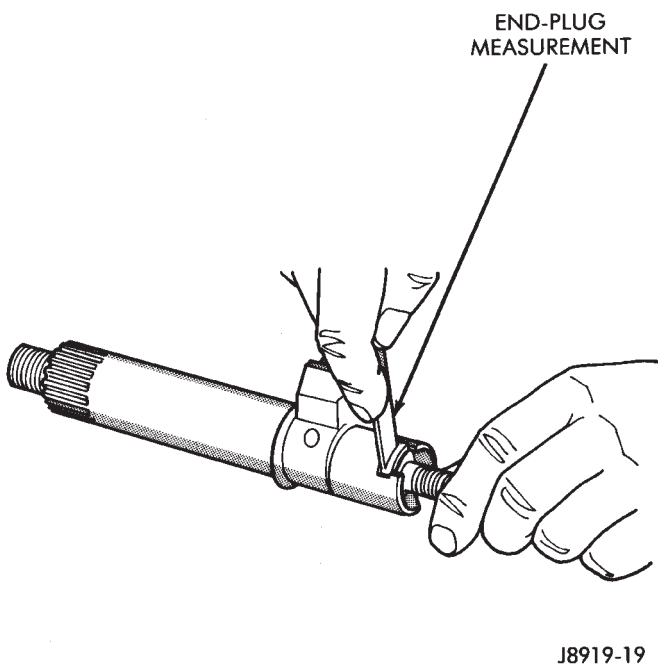

Fig. 9 Adjustment Screw End-Play Measurement

(7) Inspect the wormshaft shaft upper bearing and bearing cup for wear, looseness, flat spots, pitting, cracks, and other damage. If either the bearing or the bearing cup is damaged, both components must be replaced.

(8) If the cup fits loosely in the housing, trial fit a replacement cup. If the replacement cup also fits loosely, replace the housing. If the replacement cup fits properly, replace only the original bearing cup.

GEAR ASSEMBLY

(1) Remove wormshaft upper bearing cup with a hammer and a brass punch (Fig. 10).

(2) Install a replacement bearing cup with an appropriate installation tool (Fig. 11).

Do not install the wormshaft or the pitman shaft seals at this time.

(3) Lubricate all the components with chassis lubricant.

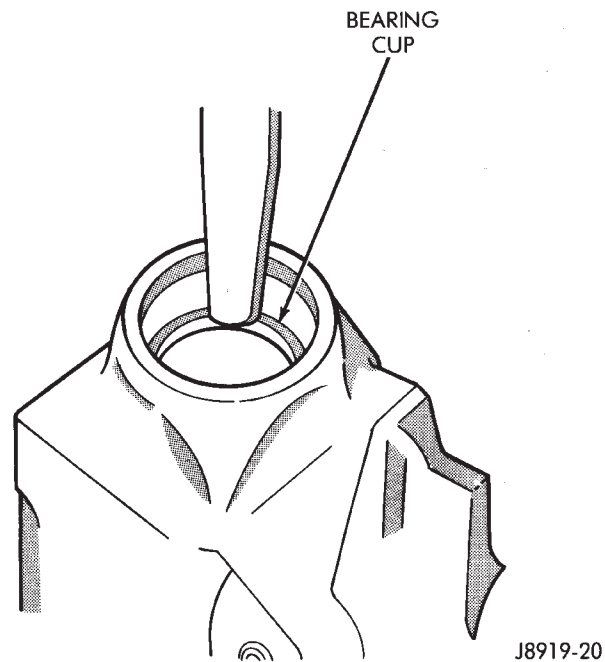

Fig. 10 Wormshaft Upper Bearing Cup Removal

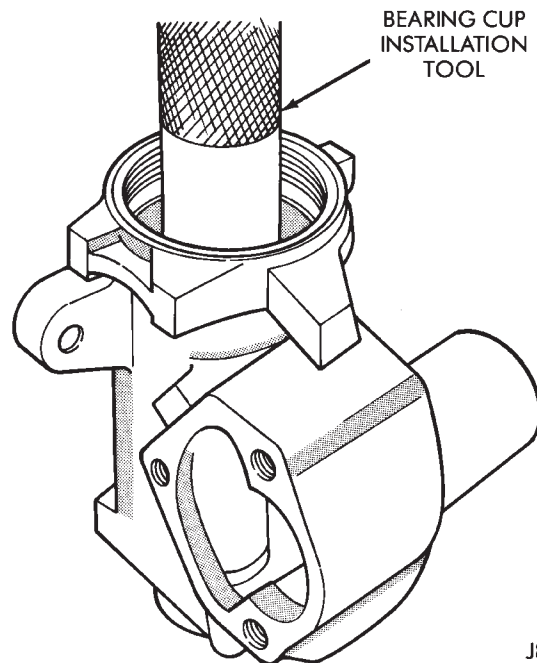

Fig. 11 Wormshaft Upper Bearing Cup Installation

(4) Place the steering gear housing in a vise. Clamp the vise jaws on the housing mounting bosses only.

(5) Install the wormshaft and ball nut in the steering gear housing.

CAUTION: Ensure that the ball nut is installed with the wide/deep side of the ball nut teeth facing toward the cover opening.

(6) Install the wormshaft bearing adjustment cap in the housing and tighten it only enough to remove the wormshaft end-play.

(7) Install the locknut on the wormshaft bearing adjustment cap but do not tighten it at this time.

(8) Pack the steering gear housing with as much chassis lubricant as possible.

Rotate the wormshaft in one direction until the ball nut ceases. Pack the end of the housing full of lubricant, rotate the shaft in the opposite direction and repeat the packing procedure.

(9) Place the ball nut (Fig. 12) in the centered position, rotate the wormshaft from stop-to-stop and count the number of rotations. Rotate wormshaft in the reverse direction 1/2 of the number of rotations to center the ball nut.

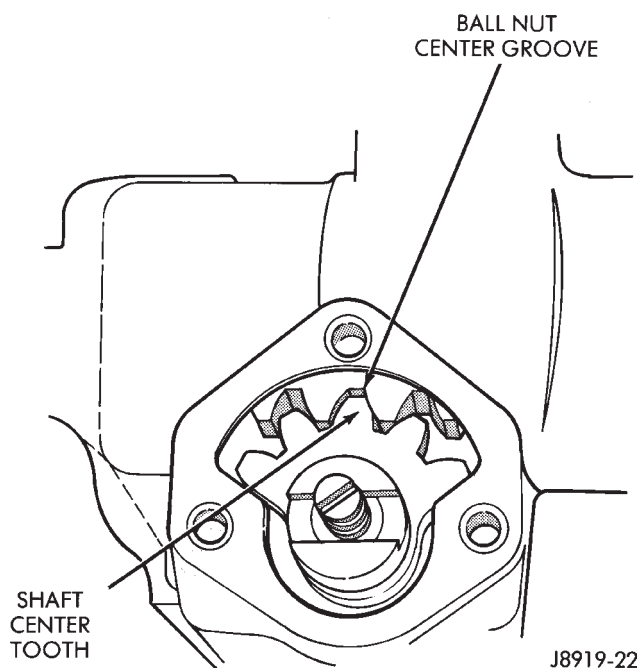

Fig. 12 Pitman Shaft & Ball Nut Engagement

(10) Lubricate the pitman shaft with chassis lubricant and insert it in the steering gear housing. Engage the center tooth on the shaft with the center groove on the ball nut.

(11) Apply chassis lubricant to the replacement housing cover gasket. Position it so that it surrounds the housing cover opening.

(12) Place the shim(s) on the adjustment screw and thread the screw into the cover to a depth of 2 to 3 threads.

(13) Slide the head of the adjustment screw into the pitman shaft T-slot. With the cover in place, rotate the screw counterclockwise to thread it into the cover. Rotate the screw until the cover almost comes in contact with the gasket.

(14) Install the cover retaining bolts finger tight only. Continue tightening the adjustment screw coun-

terclockwise until cover is tight against the gasket, then loosen the screw 1/2 rotation.

(15) Tighten the cover bolts to 61 N·m (45 ft. lbs.) torque.

(16) Install the pitman shaft seal, refer to the replacement procedure.

(17) Rotate the wormshaft and observe the steering gear operation. With the adjustment screw and cap loose, the wormshaft should rotate freely and not bind. If the steering gear binds, repair as necessary.

(18) Inspect for lubricant leakage from the shaft seals. If there is a leak at either seal, replace the defective seal(s).

GEAR ADJUSTMENTS ON BENCH

WORM BEARING PRELOAD

(1) Tighten the worm bearing adjuster plug until it bottoms, then loosen 1/4 turn.

(2) Carefully turn the wormshaft all the way to the end of travel, then turn back 1/2 turn.

(3) Tighten adjuster plug until torque wrench indicates 0.6 to 1.0 N·m (5 to 8 in. lbs.) torque (Fig. 13).

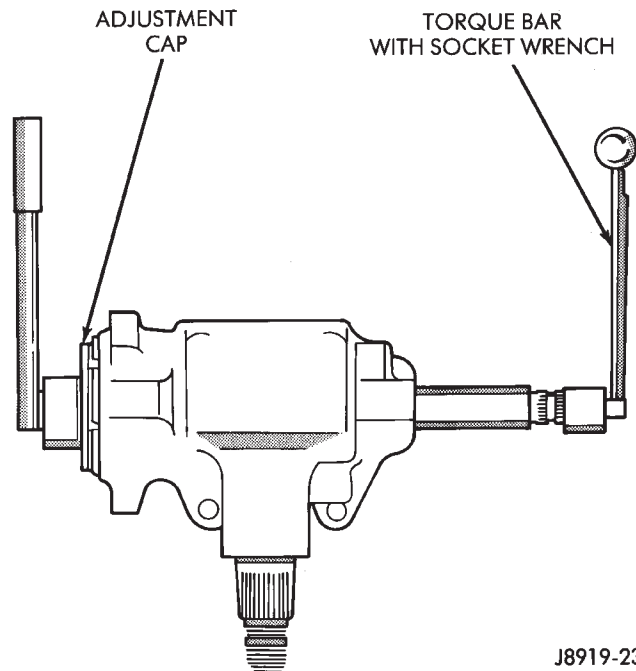

Fig. 13 Worm Bearing Preload Adjustment

(4) Tighten the adjuster plug locknut to 68 N·m (50 ft. lbs.) torque.

OVER-CENTER PRELOAD

(1) Back off preload adjuster until it stops, then turn it in one full turn.

(2) With gear at center of travel, check torque to turn stub shaft. This will be reading #1 (Fig. 14).

(3) Turn adjuster in until torque to turn stub shaft is 0.5 to 1 N·m (4 to 10 in. lbs.) more than reading #1.

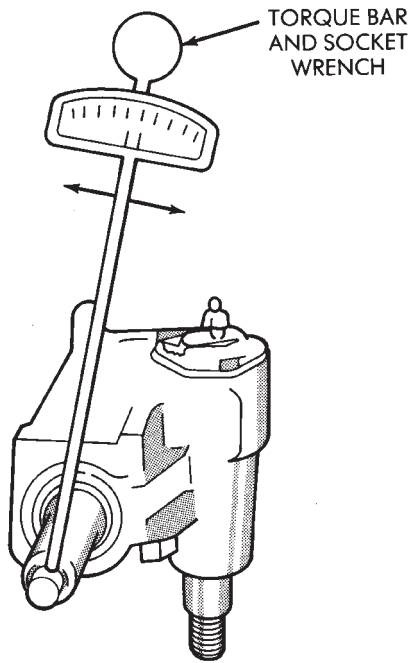

J8919-24

Fig. 14 Over-center Adjustment

(4) Hold pitman shaft adjustment screw and tighten adjuster lock nut to 34 N·m (25 ft. lbs.) torque.

INTERMEDIATE (COUPLER) SHAFT

REMOVAL

- (1) Place the front wheels in the straight ahead position.
- (2) Remove the shaft pinch bolt at the steering gear and column (Fig. 15, 16). Un-bolt steering gear from frame rail to remove shaft. Refer to Steering Gear Replacement in this section.

INSTALLATION

- (1) Align the intermediate (coupler) shaft to the steering gear and column.
- (2) Position the steering gear on the frame. Refer to Steering Gear Replacement in this section.
- (3) Install and tighten the pinch bolts to 34 N·m (25 ft. lbs.) torque.

STEERING GEAR REPLACEMENT

REMOVAL

- (1) Place the front wheels in the straight ahead position with the steering wheel centered.
- (2) Remove the column coupler shaft from the gear. Refer to the removal procedures in this section.
- (3) Remove pitman arm from gear. Refer to Pitman Arm Removal in the Steering Linkage section.

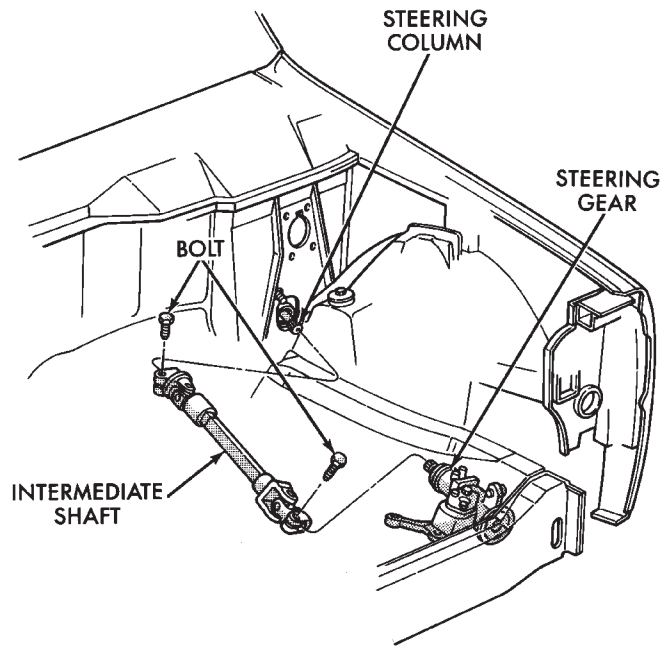

J9119-48

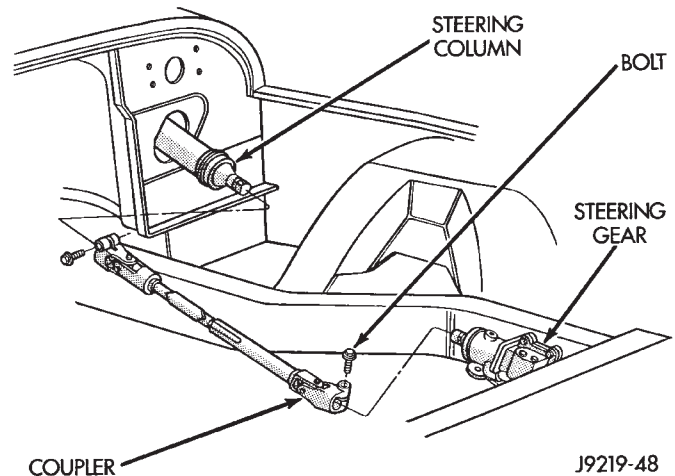
Fig. 15 Coupler Shaft—XJ

J9219-48

Fig. 16 Coupler Shaft—YJ

(4) Remove the steering gear retaining bolts and nuts. Remove the steering gear from the vehicle (Fig. 17, 18).

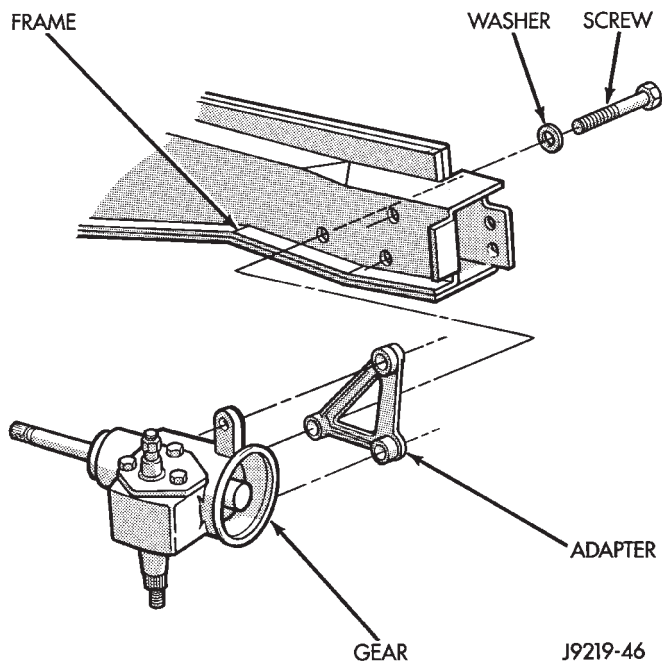

Fig. 17 Steering Gear Mounting—XJ

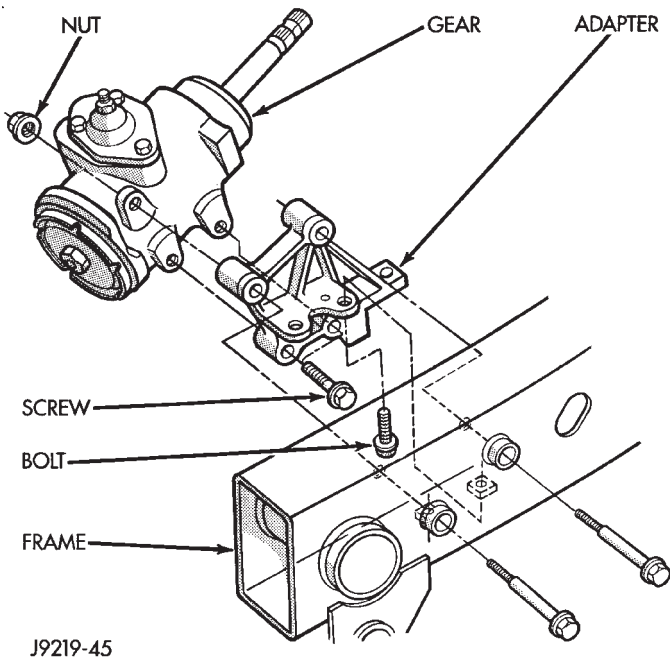

Fig. 18 Steering Gear Mounting—YJ

INSTALLATION

(1) Align the column coupler shaft to steering gear. Refer to Column Coupler installation in this section.

(2) Position the steering gear (and bracket) on the frame rail and install the bolts.

- XJ—Tighten the bolts to 95 N·m (70 ft. lbs.) torque.
- YJ—Tighten the bolts to 105 N·m (78 ft. lbs.) torque.

(3) Align and install the pitman arm. Refer to Pitman Arm Installation in the Steering Linkage section.

MANUAL STEERING GEAR SPECIFICATIONS

Wormshaft Bearing Preload Torque	0.6-0.9 N·m (5 to 8 in-lbs)
Pitman Shaft Overcenter Drag Torque	0.5-1 N·m (4 to 10 in-lbs) (in addition to above)
Maximum Steering Gear Torque	2 N·m (18 in-lbs) total (maximum)
Steering Gear Lubricant	Multi-purpose chassis grease
Steering Gear Ratio	24:1
Steering Gear Type	Recirculating Ball

J9019-2

STEERING COLUMN GENERAL SERVICE—XJ

INDEX

page

Airbag System 47

AIRBAG SYSTEM

WARNING: THE MECHANICAL AIRBAG SYSTEM IS A SENSITIVE, COMPLEX MECHANICAL UNIT. BEFORE ATTEMPTING TO REMOVE OR INSTALL THE AIRBAG SYSTEM OR RELATED STEERING WHEEL AND STEERING COLUMN COMPONENTS YOU MUST FIRST DISARM THE AIRBAG FIRING MECHANISM. FAILURE TO DO SO COULD RESULT IN ACCIDENTAL DEPLOYMENT AND POSSIBLE INJURY.

WARNING: THE AIRBAG MODULE INFLATOR/SENSOR ASSEMBLY CONTAINS SODIUM AZIDE AND POTASSIUM NITRATE. THESE MATERIALS ARE POISONOUS AND EXTREMELY FLAMMABLE. CONTACT WITH ACID, WATER OR HEAVY METALS MAY PRODUCE HARMFUL AND IRRITATING GASES (SODIUM HYDROXIDE IS FORMED IN THE PRESENCE OF MOISTURE) OR COMBUSTIBLE COMPOUNDS.

DO NOT ATTEMPT TO DISMANTLE THE MODULE OR TAMPER WITH ITS ARMING LEVER. DO NOT PUNCTURE, INCINERATE, OR BRING INTO CONTACT WITH ELECTRICITY. DO NOT STORE AT TEMPERATURES EXCEEDING 200°F.

WARNING: REPLACE AIRBAG SYSTEM COMPONENTS WITH PARTS SPECIFIED IN THE CHRYSLER MOPAR PARTS CATALOG ONLY. IT IS OF PARTICULAR IMPORTANCE THAT ANY COMPONENTS USED IN THIS MECHANICALLY-FIRED AIRBAG SYSTEM NOT BE MIXED WITH COMPONENTS FROM AN ELECTRICALLY-FIRED AIRBAG SYSTEM. SUBSTITUTE PARTS MAY APPEAR THE SAME, BUT INTERNAL DIFFERENCES MAY RESULT IN INFERIOR OCCUPANT PROTECTION.

WARNING: THE FASTENERS, SCREWS, AND BOLTS, ORIGINALLY USED FOR THE AIRBAG COMPONENTS, HAVE SPECIAL COATINGS AND ARE SPECIFICALLY DESIGNED FOR THE AIRBAG SYSTEM. THEY MUST NEVER BE REPLACED WITH ANY SUBSTITUTES. ANYTIME A NEW FASTENER IS NEEDED, REPLACE WITH THE CORRECT FASTENERS PROVIDED IN THE SERVICE PACKAGE OR SPECIFIED IN THE CHRYSLER MOPAR PARTS CATALOG.

GENERAL INFORMATION

The airbag system is a standard equipment safety device on XJ (Cherokee) models. It is designed to protect the driver from serious injury, caused by a frontal impact of the vehicle. If the airbag module assembly is defective and non-deployed, refer to Chrysler Corporation current return list for proper handling procedures.

ARMING/DISARMING MECHANISM

BEFORE SERVICING A COLUMN EQUIPPED WITH AIR BAG, REFER TO GROUP 8M, ELECTRICAL FOR PROPER AND SAFE PROCEDURES.

The steering wheel hub incorporates an airbag Arming/Disarming mechanism and a specially designed nut-blocker. The nut-blocker serves as a safety to prevent removal of the airbag module until the unit has been disarmed. A removable plastic cover plug on the top, outer hub of the steering wheel allows access to the arming screw.

When the airbag module is disarmed, the arming screw extends upward from the steering wheel hub. This will prevent installation of the plastic cover plug. Also, the nut-blocker is retracted to allow access to the two upper airbag module mounting nuts.

When the airbag module is armed, the plastic cover plug will install flush with the outer surface of the steering wheel hub. In addition, the nut-blocker will prevent access to the two upper airbag module mounting nuts.

THE FASTENERS, SCREWS, AND BOLTS, ORIGINALLY USED FOR THE AIR BAG COMPONENTS, HAVE SPECIAL COATINGS. THIS HARDWARE IS SPECIFICALLY DESIGNED FOR THE AIR BAG SYSTEM. THEY MUST NEVER BE REPLACED WITH ANY SUBSTITUTES. REPLACE WITH THE CORRECT FASTENERS PROVIDED IN THE SERVICE PACKAGE OR FASTENERS IN THE PARTS BOOK.

The Acustar columns (Fig. 1) have been designed to be serviced as an assembly; less wiring, switches, shrouds, steering wheel, etc. Most steering column components can be serviced without removing the column from the vehicle. For additional information on electrical components refer to Group 8, Electrical.

CAUTION: Bumping, jolting and hammering on the steering column shaft must be avoided during all service procedures.

CAUTION: Disconnect negative (ground) cable from the battery before servicing any component on the column.

Safety goggles should be worn at all times when involved with steering column service.

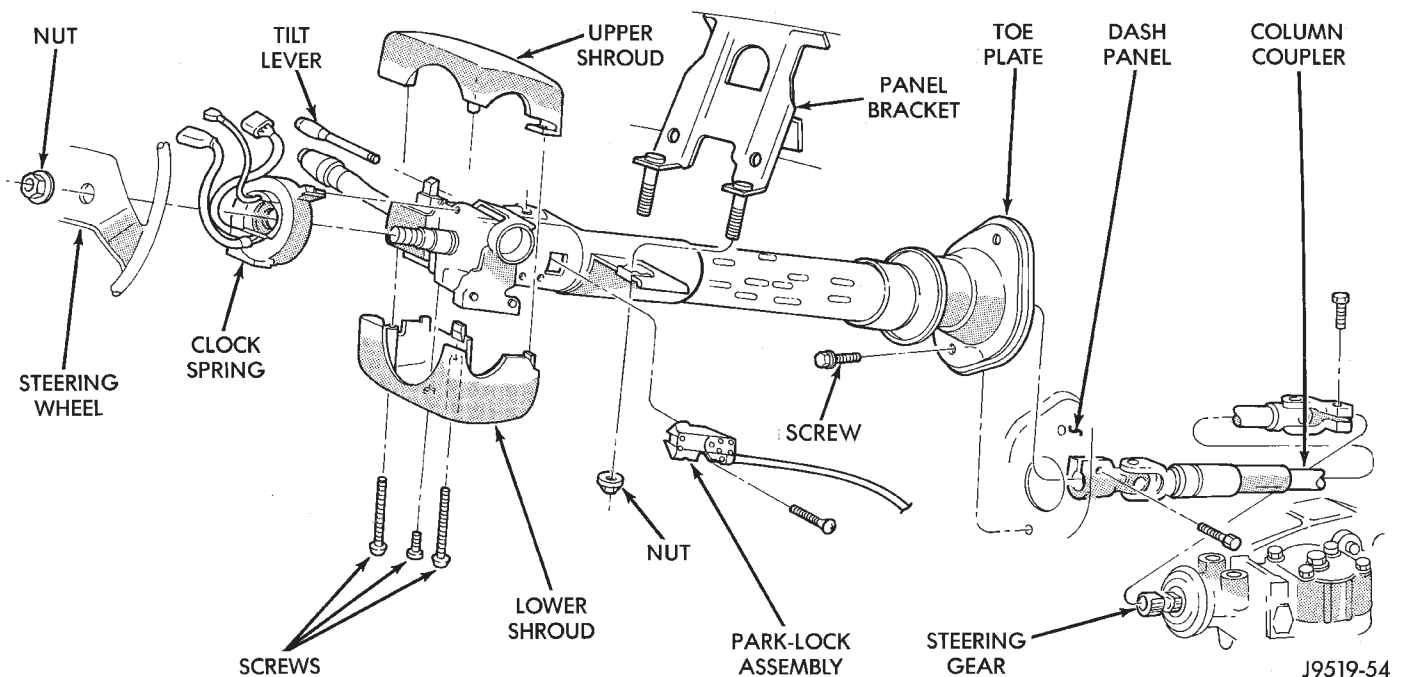

Fig. 1 Acustar Steering Column

AIRBAG MODULE REMOVE—INSTALL

WARNING: THIS AIRBAG SYSTEM IS A SENSITIVE, COMPLEX MECHANICAL UNIT. BEFORE ATTEMPTING TO REMOVE OR INSTALL THE AIRBAG SYSTEM OR RELATED STEERING WHEEL AND STEERING COLUMN COMPONENTS YOU MUST FIRST DISARM THE AIRBAG FIRING MECHANISM. FAILURE TO DO SO COULD RESULT IN ACCIDENTAL DEPLOYMENT AND POSSIBLE PERSONAL INJURY.

When removing a deployed airbag module, rubber gloves, eye protection and long-sleeved shirt should be worn. There may be deposits on the airbag module and other interior surfaces, which can cause irritation to the skin and eyes in large doses.

- (1) Disconnect battery negative cable and isolate.
- (2) Using a small screwdriver, remove plastic cover plug from top outer surface of steering wheel hub (Fig 2). Exit vehicle and disarm airbag by reaching through driver's side window and turning arming screw counter-clockwise to its travel limit (Fig 3 and 4). This is done using an 8mm socket and manual drive. **DO NOT USE POWER-DRIVEN TOOLS.**

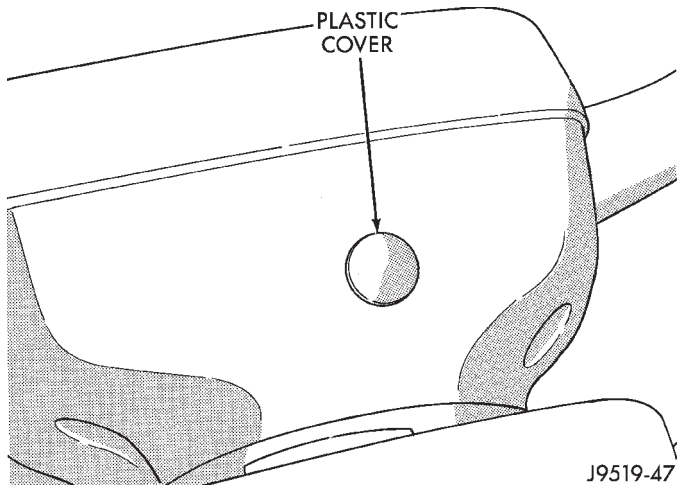

Fig. 2 Plastic Cover Plug for Airbag Arming/Disarming Bolt

- (3) From back side of steering wheel, remove 4 nuts attaching airbag module to steering wheel (Fig. 5). This is done using a 10mm socket and manual drive. **DO NOT USE POWER-DRIVEN TOOLS.**

- (4) Remove airbag module from steering wheel.

- (5) Reverse removal procedures to install. Tighten airbag module attaching nuts to 9 to 11 N·m (80 to 100 in. lbs.). Exit vehicle and arm airbag by reaching through driver's side window and turning arming screw clockwise to its travel limit. Arming screw torque should not exceed 1.1 to 1.7 N·m (10-15 in. lbs.). Reinstall plastic cover plug in steering wheel hub.

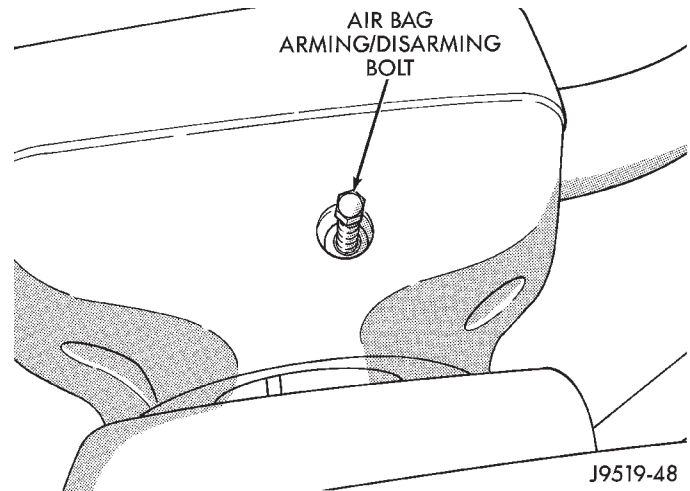

Fig. 3 Arming/Disarming Bolt

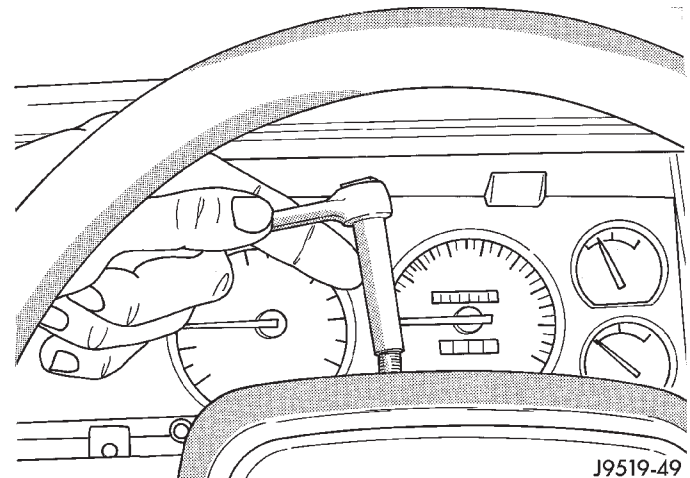

Fig. 4 Airbag Bolt

STEERING WHEEL

WARNING: BEFORE ATTEMPTING TO REMOVE OR INSTALL THE AIRBAG SYSTEM OR RELATED STEERING WHEEL AND STEERING COLUMN COMPONENTS YOU MUST FIRST DISARM THE AIRBAG FIRING MECHANISM. WHEN SERVICING AIR BAG SYSTEM, REMOVE AND ISOLATE THE BATTERY NEGATIVE (-) CABLE (GROUND) FROM THE VEHICLE BATTERY. YOU MUST DISARM THE AIRBAG FIRING MECHANISM. FAILURE TO DO SO COULD RESULT IN ACCIDENTAL AIR BAG DEPLOYMENT AND POSSIBLE INJURY. WHEN AN UNDEPLOYED AIR BAG ASSEMBLY IS TO BE REMOVED FROM THE STEERING WHEEL, DISCONNECT THE BATTERY GROUND CABLE AND ISOLATE. THE ARMING SCREW MUST BE USED TO DISARM THE AIRBAG.

REMOVAL

- (1) Make sure the front wheels are in the **straight ahead** position and steering column locked in place.

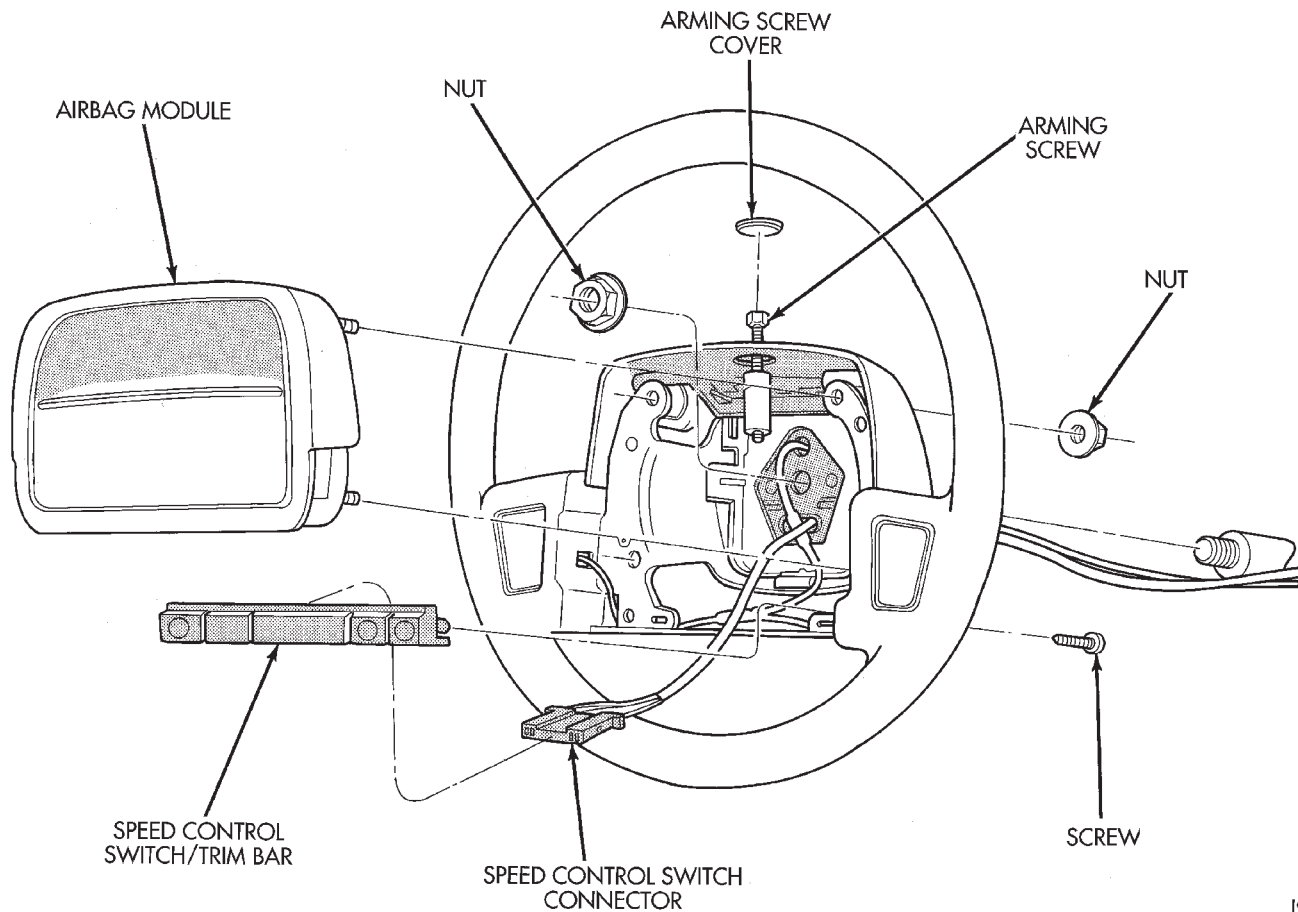

J958M-3

Fig. 5 Airbag Module Remove/Install

(2) Disconnect the battery negative (ground) cable and isolate.

(3) Disarm the airbag (refer to group 8M, Electrical for proper and safe procedures).

(4) Remove the air bag module and speed control switch (if equipped) and disconnect the wire feeds (Fig. 6).

(6) Remove the steering wheel retaining nut. Score or paint alignment marks on the column shaft and steering wheel (if none exist) for installation reference.

(7) Remove the steering wheel with a universal puller (Fig. 7). **Do not hammer or jolt the steering column or shaft during removal of the wheel.**

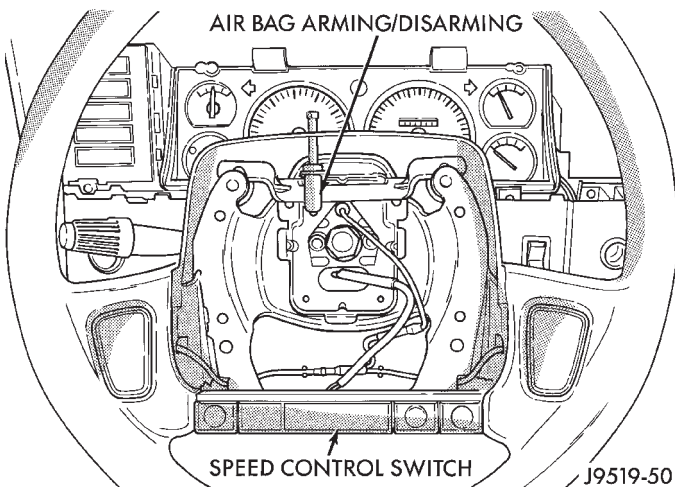

J9519-50

Fig. 6 Air Bag Module and Speed Control

(5) Disconnect the wire feed to the horn buttons.

INSTALLATION

(1) Install the steering wheel on column with the scored marks or master splines aligned. Ensure the wheel compresses the 2 lock tabs on the clockspring.

(2) Pull the speed control wires through the lower, larger hole in the steering wheel. Pull the horn wire through the smaller hole at the top.

(3) Install the retaining nut and tighten to 61 N·m (45 ft. lbs.) torque. **Force the steering wheel down on the shaft with the retaining nut only. Do not hammer or shock the column with sudden impact to install the wheel.**

(4) Connect the wire feed to the horn buttons.

(5) Connect the wire feeds to the speed control switch (Fig. 6). Tighten the air bag module nuts to 9 to 11 N·m (80 to 100 in. lbs.) torque.

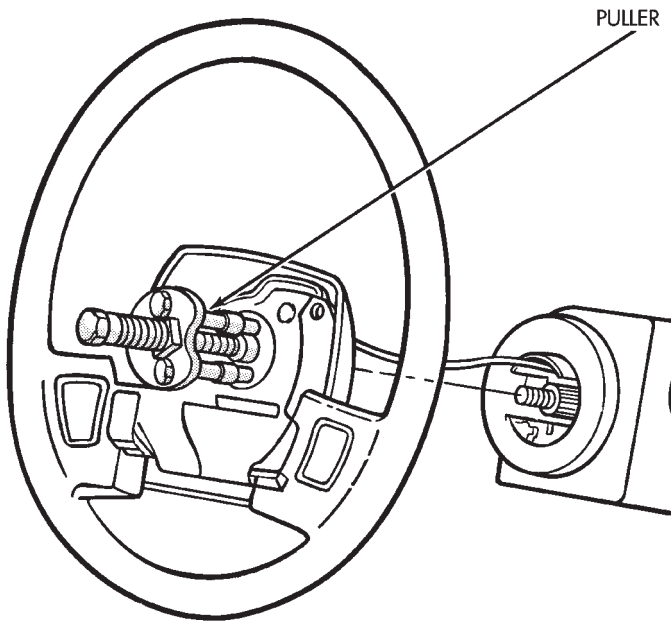

J9319-10

Fig. 7 Steering Wheel Removal

CLOCKSPRING

WARNING: BEFORE SERVICING AIR BAG SYSTEM, REMOVE AND ISOLATE BATTERY NEGATIVE (-) CABLE (GROUND) FROM VEHICLE BATTERY. WHEN AN UNDEPLOYED AIR BAG ASSEMBLY IS TO BE REMOVED FROM THE STEERING WHEEL, DISCONNECT THE BATTERY GROUND CABLE AND ISOLATE.

REMOVAL

- (1) Place the front wheels in the straight ahead position before starting the repair.
- (2) Disconnect battery negative cable and isolate.
- (3) Remove the steering wheel and air bag, refer to Steering Wheel Removal.
- (4) Remove upper and lower steering column shrouds to gain access to the clockspring wiring (Fig. 8).
- (5) Release wire connector at clockspring.
- (6) Pull clockspring assembly from column by lifting locking fingers as necessary. The clockspring cannot be repaired, and must be replaced if faulty.

INSTALLATION

- (1) Snap clockspring assembly onto column. If clockspring is not properly positioned, follow the centering procedures before installing steering wheel.
- (2) Connect the wire connector to the clockspring.
- (3) Install upper and lower steering column shrouds. Be sure wiring is inside of shrouds and not pinched.
- (4) Install the steering wheel and air bag module, refer to Steering Wheel Installation.

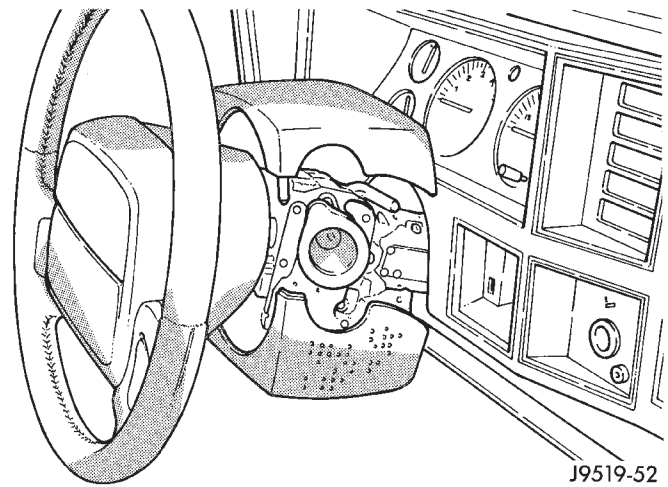

J9519-52

Fig. 8 Upper and Lower Steering Column Shroud

CENTERING PROCEDURE

If the rotating tape within the clockspring is not positioned properly, the clockspring may fail during use. The following procedures **MUST BE USED** to center the clockspring;

- If it is not known to be properly positioned
- If the front wheels were moved from the straight ahead position

- (1) Place the front wheels in the straight ahead position before starting the procedure.
- (2) Depress the 2 locking tabs to disengage the locking mechanism (Fig. 9).

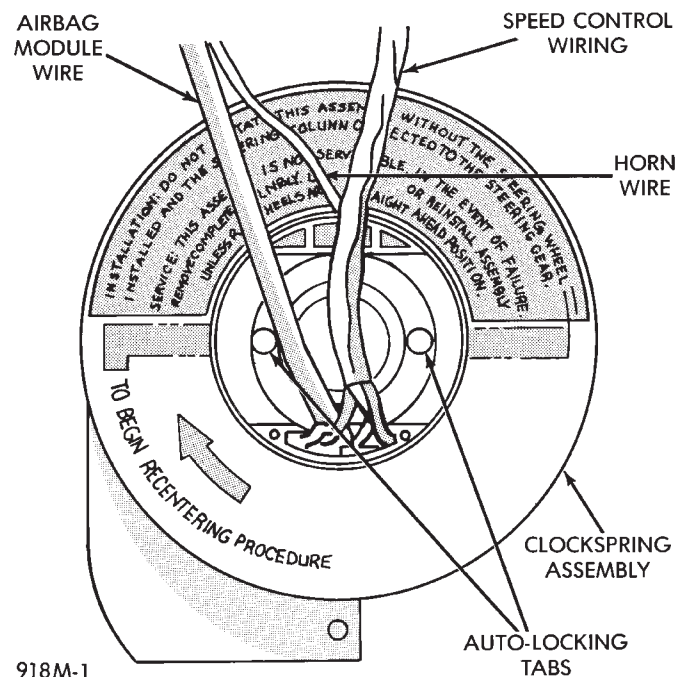

918M-1

Fig. 9 Clockspring—Auto-Locking

- (3) Keeping the mechanism disengaged, rotate the clockspring rotor in the **CLOCKWISE DIRECTION** to the end of the travel. Do not apply excessive torque.

(4) From the end of travel, rotate the rotor 2 1/2 full turns in the COUNTER CLOCKWISE direction. The horn wire should end up at the top and the squib wire at the bottom (Fig. 9).

(5) Install the steering wheel and air bag module, refer to Steering Wheel Installation.

COLUMN ASSEMBLY REPLACEMENT

CAUTION: Bumping, jolting and hammering on the steering column shaft and gear shift tube must be avoided during all service procedures.

REMOVAL

(1) Make sure the front wheels are in the **straight ahead** position.

(2) Observe Cautions and disconnect the negative (ground) cable from the battery.

(3) Disarm airbag, refer to Arming/Disarming Airbag in this section.

(4) Remove column coupler upper pinch bolt (Fig. 10).

(5) Remove steering wheel and airbag from column, refer to Steering Wheel-Removal and observe Cautions/Warnings.

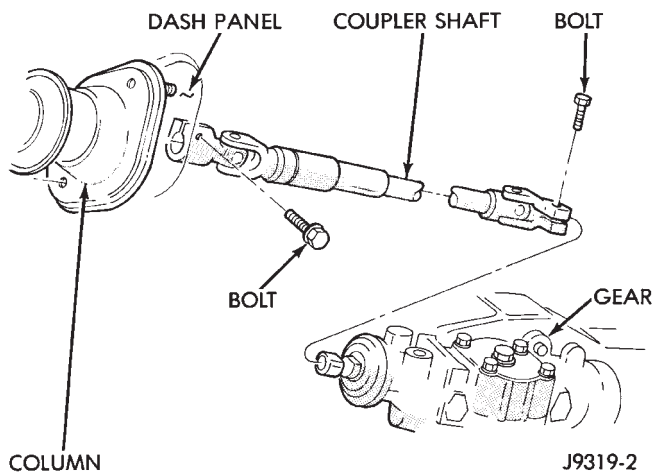

Fig. 10 Column Coupler Shaft

(6) Remove the knee blocker (Fig. 11).
 (7) Remove relay box.
 (8) Remove tilt lever (if equipped) from column.
 (9) Remove the upper and lower steering column shrouds (Fig. 8).

(10) Remove both pencil braces (fig. 12).

(11) Loosen the panel bracket nuts/studs to allow the column to drop.

(12) Remove wiring harness connector (Fig. 15) from the multi function switch. **Note: Wiring harness connector is retained to multi function switch, using an attaching bolt with a 7mm hex head. access to bolt is through rear of wiring harness connector.**

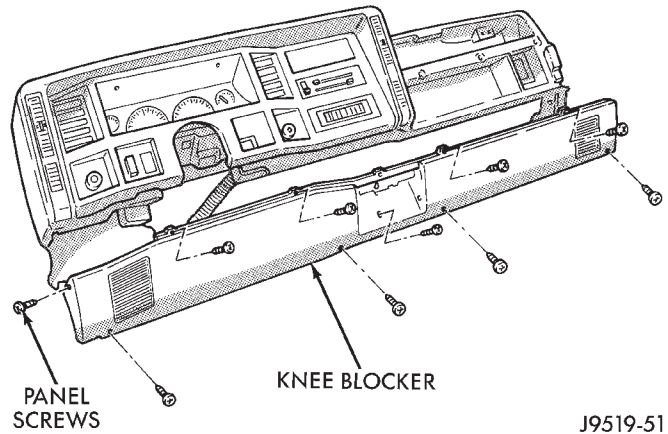

Fig. 11 Knee Blocker

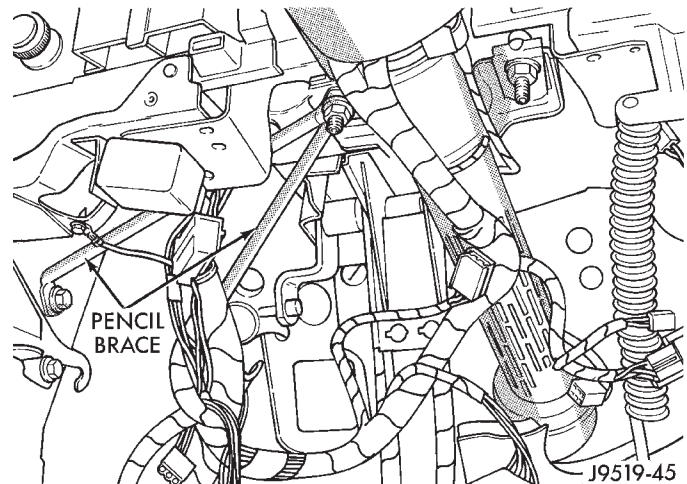

Fig. 12 Steering Column Pencil Braces

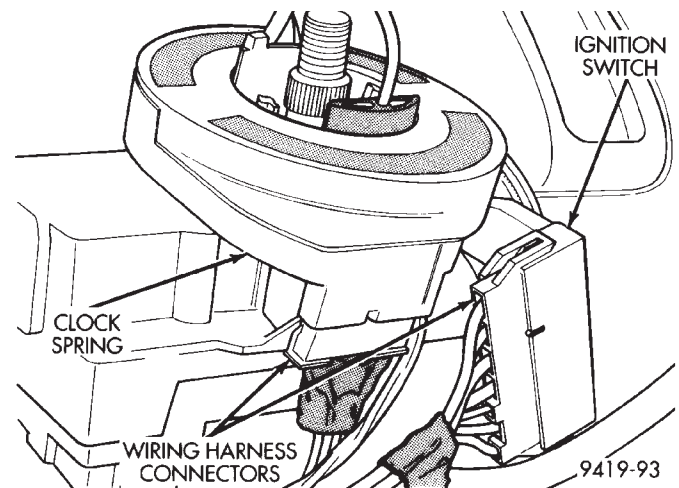

Fig. 13 Clock Spring And Ignition Switch Wiring Connections

(13) Remove the wiring harness from steering column (Fig. 16).

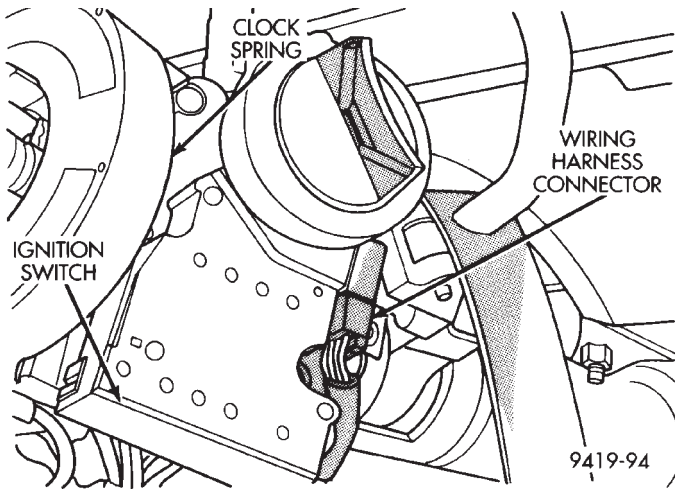

Fig. 14 Halo Light And Key In Buzzer Wiring Connection

- (14) Remove the Interlock cable from the steering column. Refer to Automatic Transmission Shifter/Ignition Interlock in this group.
- (15) Remove the column. Use care to avoid damaging the paint or trim.

INSTALLATION

CAUTION: Bumping, jolting and hammering on the steering column shaft and gear shift tube must be avoided during all service procedures.

- (1) With the front wheels in the straight ahead position. Align and install the column to coupler. **Do not apply force at the top of the steering column shaft.**

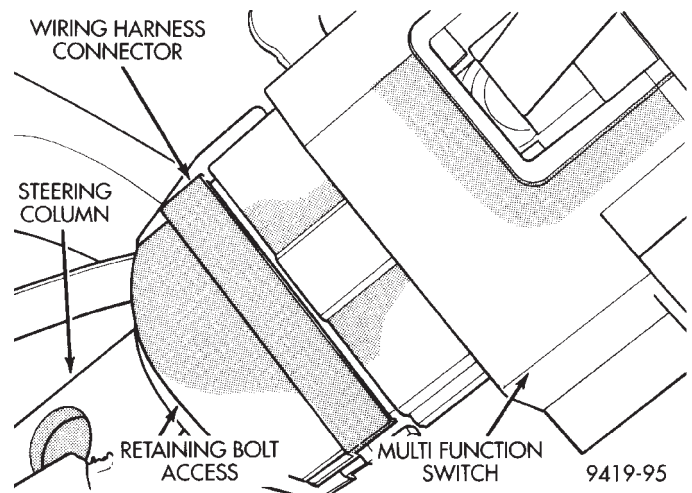

Fig. 15 Multi Function Switch Wiring Connection

- (2) Ensure the ground clip is on the left spacer slot (Fig. 17).
- (3) Install the Interlock cable from the steering column. Refer to Automatic Transmission Shifter/Ignition Interlock in this group.
- (4) Install wiring harness connections to steering column (Fig. 16). **Ensure the wiring is not pinched and all connections are correctly locked in place.**
- (5) Install wiring harness connector onto multi function switch (Fig. 18). Torque multi function switch wiring harness connector retaining bolt to 2 N·m (17 in. lbs.).
- (6) Install wiring harness connector for key light switch connection, onto the ignition switch (Fig. 19).

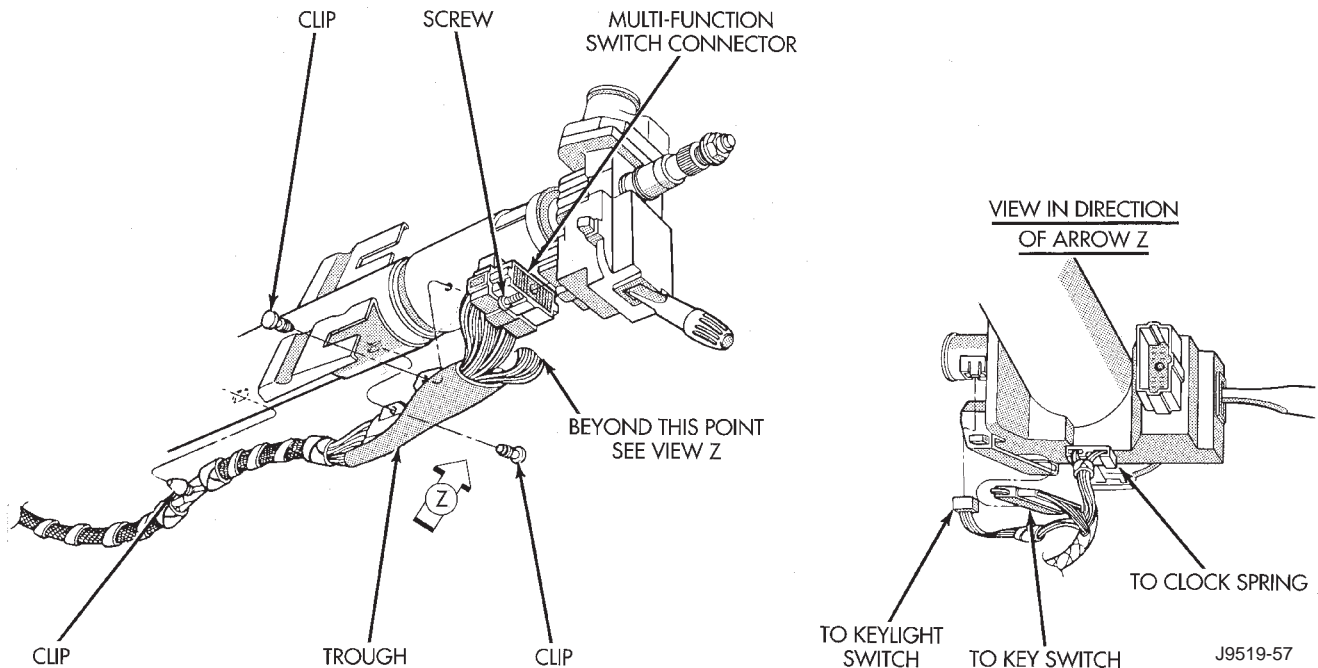

Fig. 16 Steering Column Wiring Harness

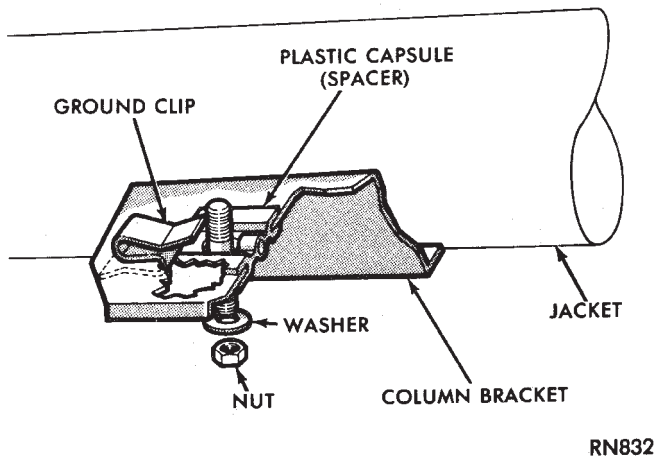

Fig. 17 Ground Clip & Spacer Installation

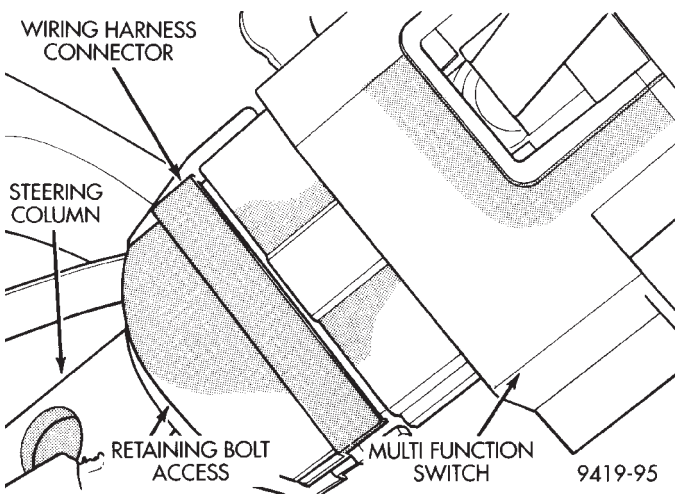

Fig. 18 Multi Function Switch Wiring Harness Connector Installed

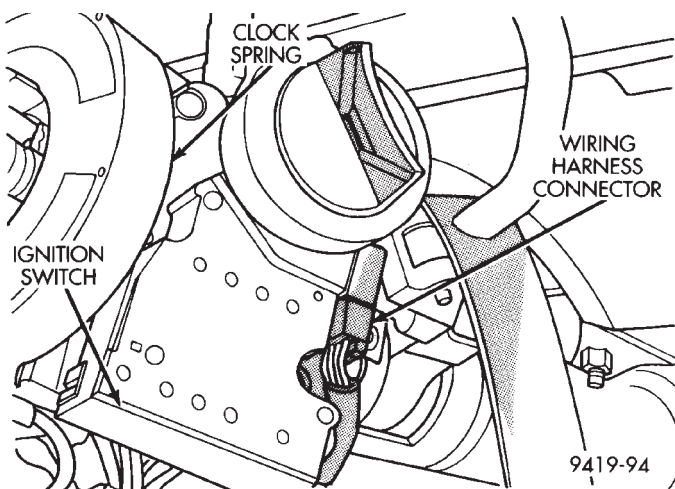

Fig. 19 Wiring Harness Connection For Key Light Switch

(7) Install wiring harness connectors onto clock spring and ignition switch assembly (Fig. 20).

(8) Install shaft coupler pinch bolt loose, load column up to panel bracket.

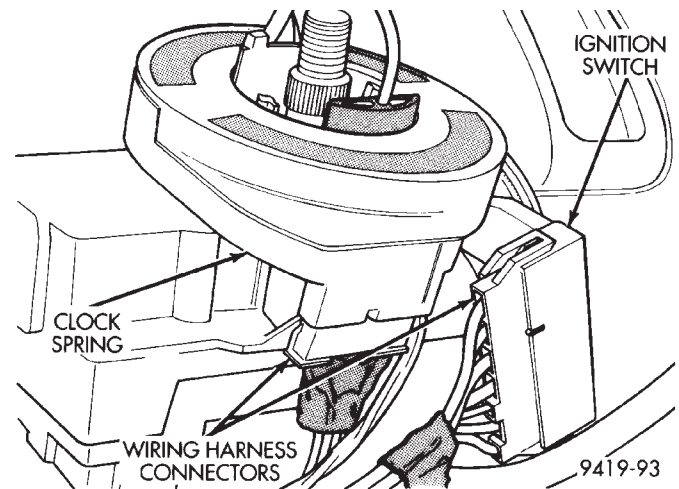

Fig. 20 Wiring Harness Connection To Clock Spring And Ignition Switch

(9) Be sure both spacers are fully seated in the column support bracket. Tighten the column panel bracket support nuts to 12 N·m (105 in. lbs.) torque.

(10) Tighten the coupler pinch bolt to 47 N·m (35 ft. lbs.) torque.

(11) Install the upper and lower shrouds. Install the tilt lever (if equipped).

(12) Install rely box.

(13) Install the knee blocker.

(14) Install the steering wheel, refer to Steering Wheel Installation and observe cautions.

(15) Remove the column shaft shipping lock pin (installed in service column).

(16) Arm airbag, refer to Arming/Disarming Airbag in this section.

(17) Connect the battery ground (negative) cable.

COLUMN COMPONENT SERVICE

The Acustar columns have been designed to be serviced as an assembly; less wiring, switches, shrouds, steering wheel, etc. Also most steering column components can be serviced without removing the column from the vehicle. For additional information on electrical components refer to Group 8, Electrical.

IGNITION SWITCH SERVICE

TEST AND REPAIR

If the ignition switch effort seems to be excessive due to binding. Follow the procedure outlined below to determine the cause.

When service procedures are performed on the Acustar steering column there are certain areas of the column that can not be tampered with. If a problem related to these areas of the steering column are detected. The entire steering column (less the removable components) should be replaced see (Fig. 1 and 2).

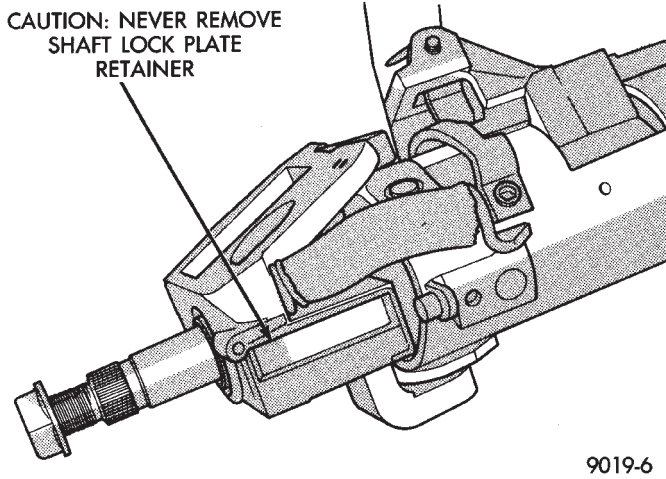

9019-6

Fig. 1 Steering Column Non-Serviceable Components

(1) Remove the ignition switch from the steering column. Refer to **Group 8D Ignition System**.

(2) Using a key cylinder, check the turning effort of the switch.

- If the ignition switch binds look for the following conditions.

(1) Look for rough areas or flash in the casting and if found remove with a file (Fig. 2).

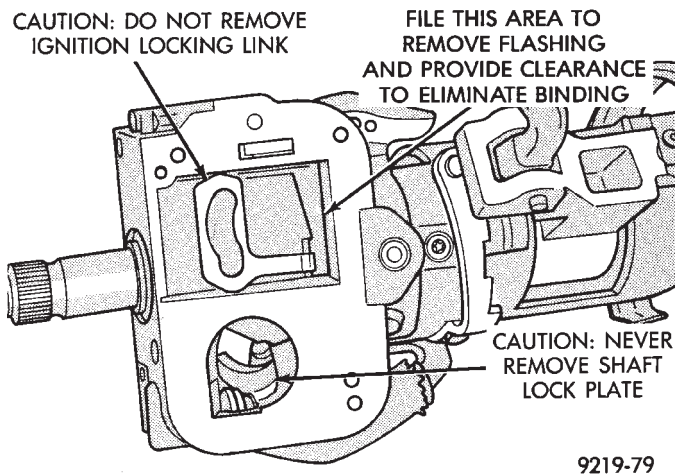

9219-79

Fig. 2 Steering Column Flash Removal And Non-Serviceable Components

(2) Remove the link and slider.

(3) Check the link to see if it has been bent and if so replace with a new part.

Put the slider in its slot in the sleeve and verify a loose fit over the length of the slot. If the slider binds in the slot at any point lightly file the slider until clearance is achieved.

- If no binding is found.

Lightly file the ramp on the ignition switch, (The ramp fits into the casting) until binding no longer occurs.

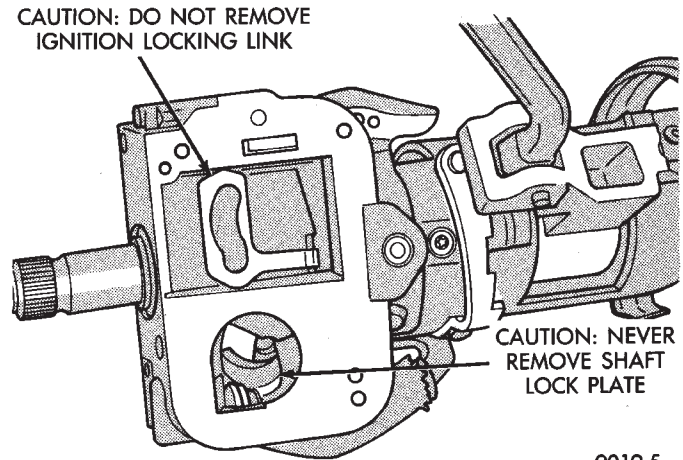

9019-5

Fig. 3 Observe Cautions

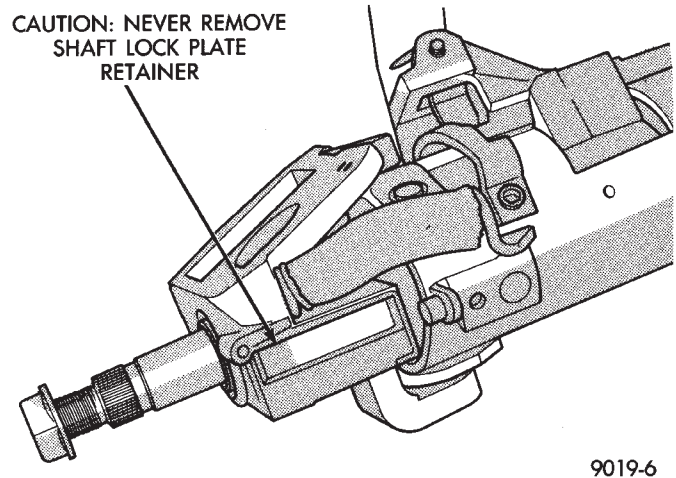

9019-6

Fig. 4 Observe Cautions

AUTOMATIC TRANSMISSION SHIFTER/IGNITION INTERLOCK MECHANISM

The automatic transmission Shifter/Ignition Interlock, is a cable operated system. It interconnects the automatic transmission floor mounted shifter to the steering column ignition switch (Fig. 1). The system locks the shifter into the PARK position. The Interlock system is engaged whenever the ignition switch is in the LOCK or ACCESSORY position. When the key is in the OFF or RUN position the shifter is unlocked and will move into any position. The interlock system also prevents the ignition switch from being turned to the LOCK or ACCESSORY position (Fig. 2). Unless the shifter is fully locked into the PARK position.

INTERLOCK CABLE REPLACEMENT

REMOVAL

(1) Lower the steering column. Refer to Column Assembly Replacement in this group.

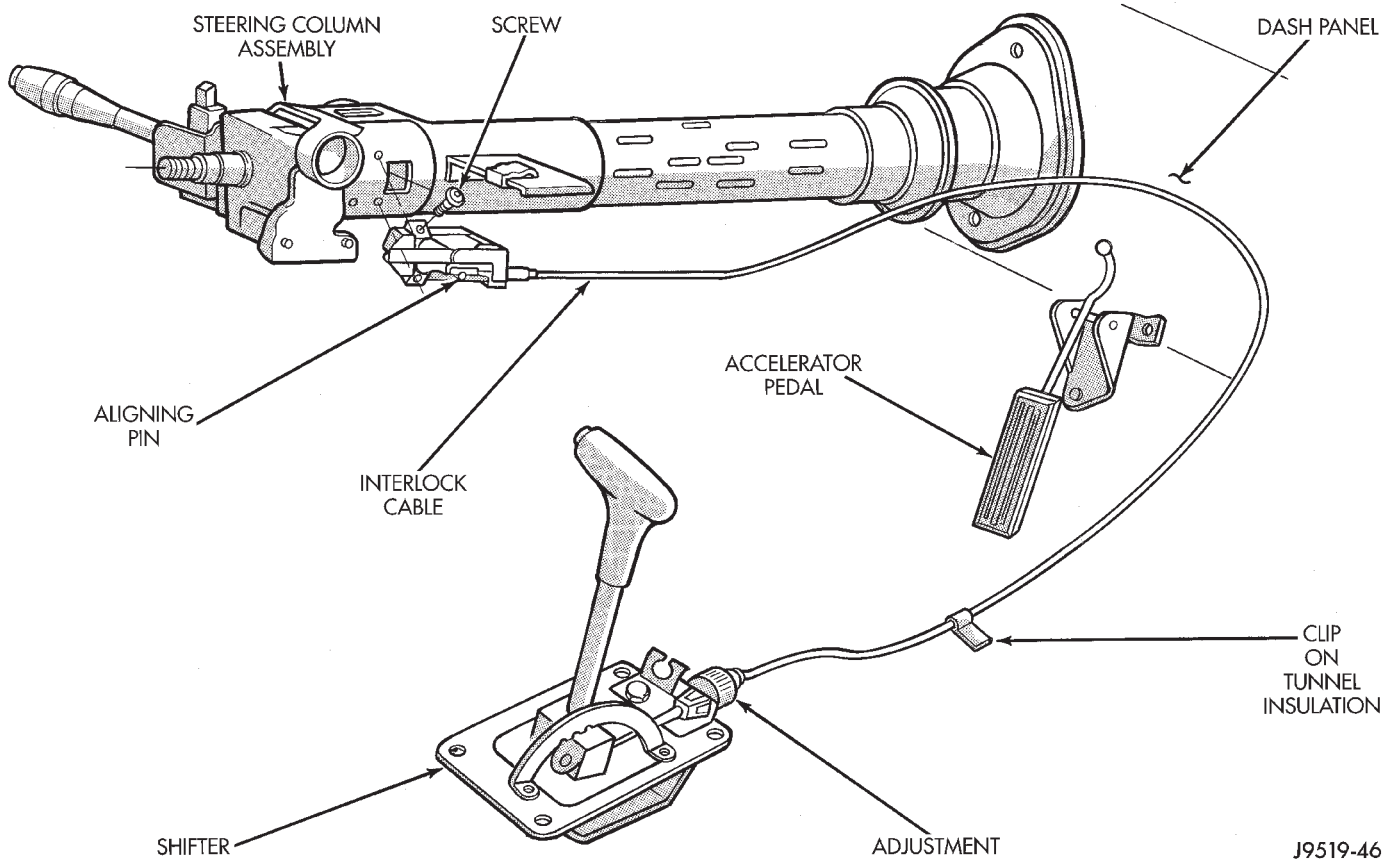

Fig. 1 Ignition Interlock Cable Routing

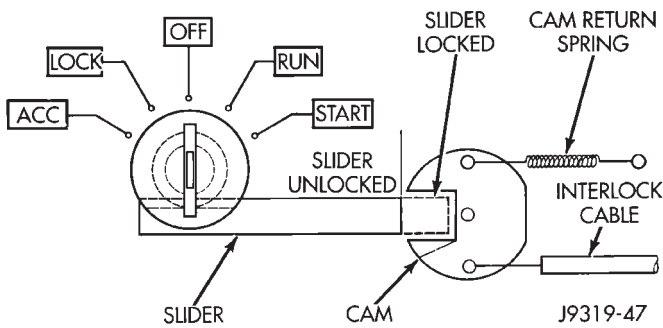

Fig. 2 Ignition Key Cylinder Actuation

(2) Remove two screws retaining the interlock mechanism to the column (Fig. 3). Unsnap the mechanism from column.

(3) Remove the center console and related trim. Refer to Group 23, Body.

(4) Disconnect the cable eyelet from the bellcrank (Fig. 4).

(5) Disconnect and remove the cable from the shift bracket.

(6) Remove the accelerator pedal (the cable routes under the pedal), refer to Group 14, Fuel Systems. Release the cable from the accelerator pedal clip. Move the carpet as necessary to remove the cable.

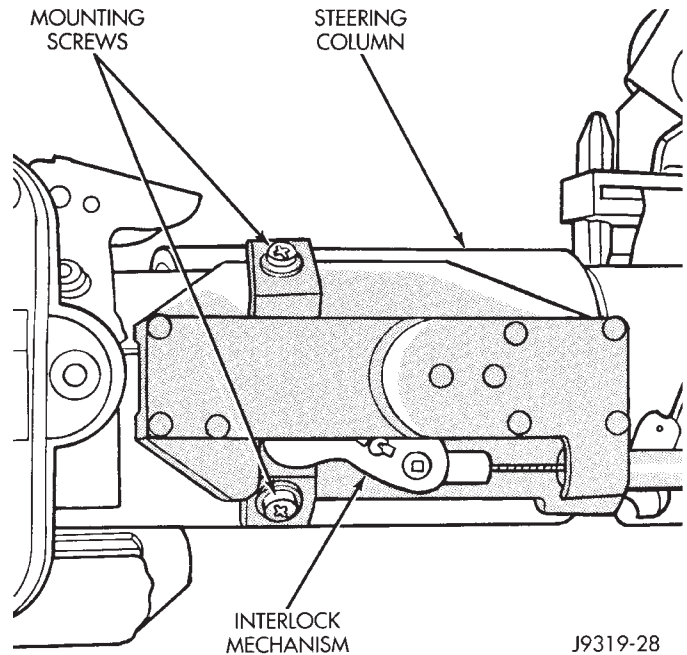

Fig. 3 Interlock Mechanism on Column

INSTALLATION/ADJUSTMENT

(1) Snap the cable base assembly into the large square opening in the steering column (Fig. 4).

(2) Secure the plastic base with two (2) self tapping screws (Fig. 3).

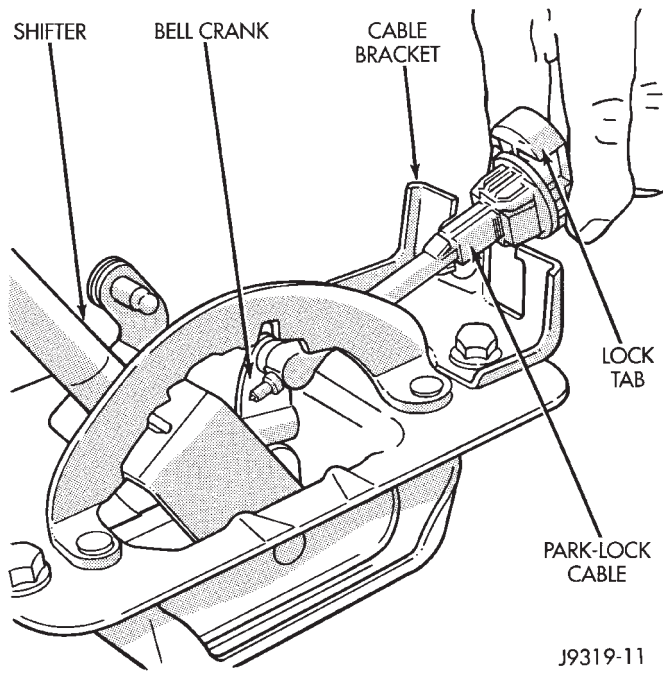

Fig. 4 Cable and Shifter

- (3) Place the ignition key cylinder in the ACCESSORY position.
- (4) Remove shipping pin from plastic base.
- (5) Connect the cable eyelet to the bellcrank pin (Fig. 4).
- (6) Place gear selector in PARK.
- (7) Push the spring-loaded cable adjuster forward and snap cable into bracket (Fig. 4).
- (8) Push the cable adjuster lock clamp downward to lock it.

(9) Install the center console and related trim. Refer to Group 23, Body.

(10) Test the park-lock cable operation.

(11) Load the steering column up to the bracket. Refer to Column Assembly Replacement in this group.

TEST/INSPECTION

- (1) Turn the ignition switch key to the LOCK position.
- (2) Press inward on the gear selector handle release button, the button should not move.
- (3) Turn the ignition switch key to the ON position.
- (4) Press inward on the gear selector handle release button.
- (5) Move the gear selector handle to the DRIVE or NEUTRAL position.
- (6) Attempt to turn the ignition switch key to the LOCK position.
- (7) If the park-lock cable is correctly adjusted, the key will not turn to the LOCK position.
- (8) Press inward on the gear selector handle release button and move the gear selector handle to the PARK position.
- (9) Turn the ignition switch key to the LOCK position. If the park-lock cable is correctly adjusted, the key will turn to the LOCK position.
- (10) If additional cable adjustment is required, slide the adjuster forward or rearward to obtain the correct position. Refer to Group 21, Transmission for additional information involving shift cable adjustment.

STEERING COLUMN—YJ

INDEX

	page		page
Assembly	63	Disassembly—Column or Console Shift	60
Assembly	71	Non-Tilt Steering Column	60
Column Replacement	58	Steering Wheel	58
Disassembly	66	Tilt Steering Column	66

The column may be disassembled and reassembled. Also most steering column components can be serviced without removing the column from the vehicle. For additional information, refer to Group 8H, Electrical.

CAUTION: Bumping, jolting and hammering on the steering column shaft and gear shift tube must be avoided during all service procedures.

CAUTION: Disconnect negative (ground) cable from the battery before servicing any component on the column.

Safety goggles should be worn at all times when involved with steering column service.

STEERING WHEEL

REMOVAL

- (1) Make sure the front wheels are in the **straight ahead** position.
- (2) Disconnect the negative (ground) cable from the battery.
- (3) Remove the horn contact components (Fig. 1).

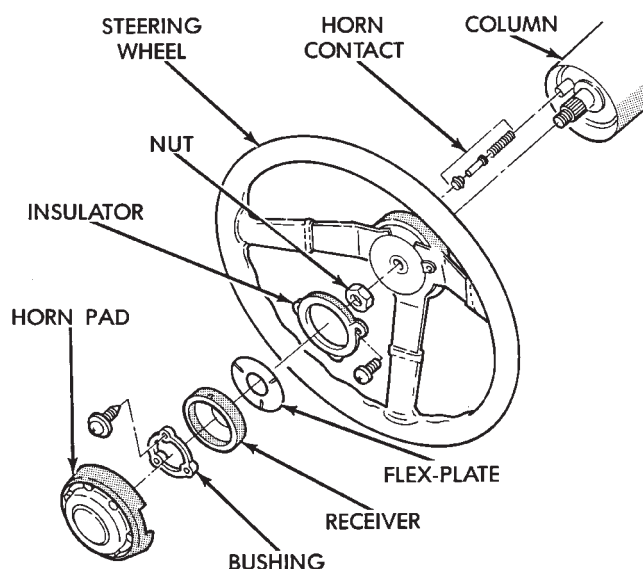
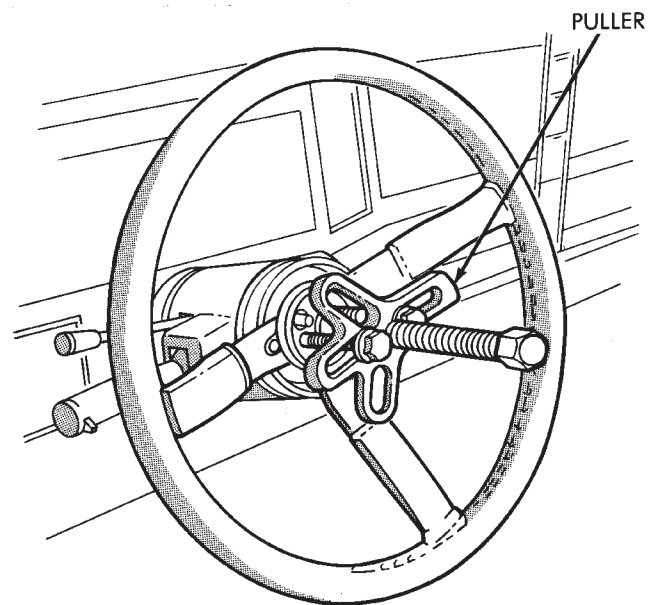

Fig. 1 Horn Pad Removal/Installation

J9219-54

- (4) Remove the steering wheel retaining nut and the vibration damper, if equipped. Score or paint alignment marks on the column shaft and steering wheel (if none exist) for installation reference.

- (5) Remove the steering wheel with Puller 7591 (Fig. 2).



J-8919-113

Fig. 2 Steering Wheel Removal

INSTALLATION

- (1) Install the steering wheel with the scored or painted marks aligned.
- (2) Install the retaining nut and tighten to 34 N·m (25 ft. lbs.) torque. **Force the steering wheel down on the shaft with the retaining nut only.**
- (3) Install the horn contact components (Fig. 1).
- (4) Connect the battery ground (negative) cable.

COLUMN REPLACEMENT

REMOVAL

CAUTION: Bumping, jolting and hammering on the steering column shaft and gear shift tube must be avoided during all service procedures.

(1) Make sure the front wheels are in the **straight ahead** position.

(2) Disconnect the negative (ground) cable from the battery.

(3) Remove steering wheel from column, refer to Steering Wheel-Removal.

(4) Column shift vehicles, disconnect the shift cable grommet by prying it from the shift lever.

(5) Disconnect the column shaft to steering gear coupler upper bolt (Fig. 3).

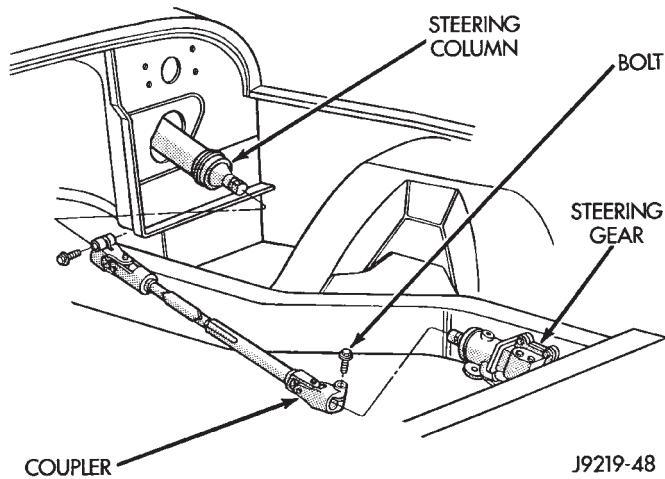

J9219-48

Fig. 3 Column Shaft Coupler

(6) Remove the lower portion of the instrument panel, refer to Group 8E, Instrument Panel.

(7) Remove two nuts holding steering column bracket to brake sled (Fig. 4).

(8) Remove four bolts holding steering column bracket to column.

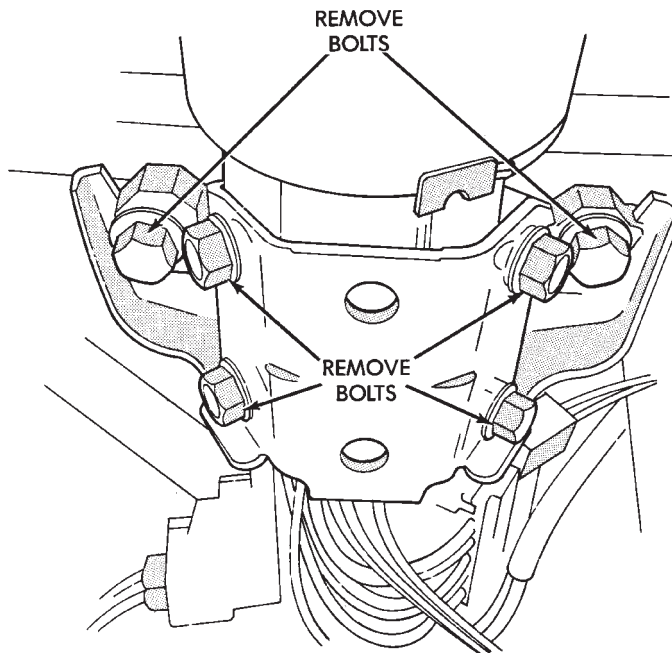

J9219-51

Fig. 4 Column Bracket

(9) Disconnect the following items from the steering column connectors:

- Ignition switch wire harness
- Dimmer switch wire harness
- Turn signal switch wire harness
- Windshield wiper wire harness
- Cruise control wire harness (if equipped)

(10) Remove the bolts that attach the toe plate to the floor pan (Fig. 5).

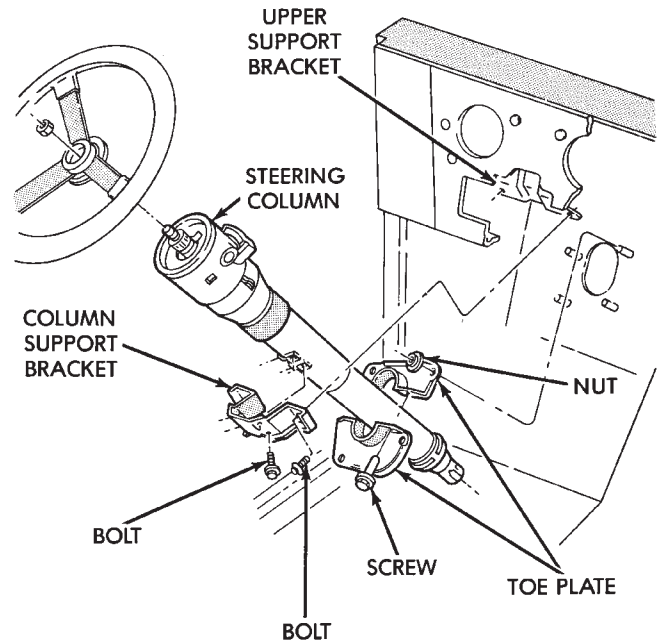

J9219-52

Fig. 5 Steering Column Mounting

(11) Carefully remove column from vehicle.

INSTALLATION

CAUTION: Bumping, jolting and hammering on the steering column shaft and gear shift tube must be avoided during all service procedures.

(1) Carefully position column in vehicle.

(2) Align the column shaft to steering gear coupling. Install and tighten the bolt to 34 N·m (25 ft. lbs.) torque.

(3) As applicable, connect the following items to the steering column connectors:

- Ignition switch wire harness
- Dimmer switch wire harness
- Turn signal switch wire harness
- Windshield wiper wire harness
- Cruise control wire harness (if equipped)

(4) Install the support bracket on the column (Fig. 4) and tighten the bolts to 30 N·m (270 in. lbs.) torque.

(5) Install and tighten the column to brake sled bolts (Fig. 4) to 30 N·m (270 in. lbs.) torque.

(6) Column shift vehicles, install the shift cable grommet on the shift lever.

(7) Install and tighten the toe plate to floor pan bolts/nuts to 21.5 N·m (192 in. lbs.) torque (Fig. 5).

(8) Install the lower portion of the instrument panel, refer to Group 8E, Instrument Panel.

(9) Install steering wheel on column, refer to Steering Wheel-Installation.

(10) Connect the negative (ground) cable to the battery.

NON-TILT STEERING COLUMN

DISASSEMBLY—COLUMN OR CONSOLE SHIFT

Steering column removal from the vehicle is not necessary for;

- Lockplate cover
- Lockplate
- Steering shaft retaining ring
- Canceling cam
- Turn signal switch
- Upper bearing preload spring
- Ignition key/lock cylinder service

The steering column must be removed from the vehicle to service any other component.

(1) If the column is removed for service, fabricate a support fixture to clamp it in a vise (Fig. 1).

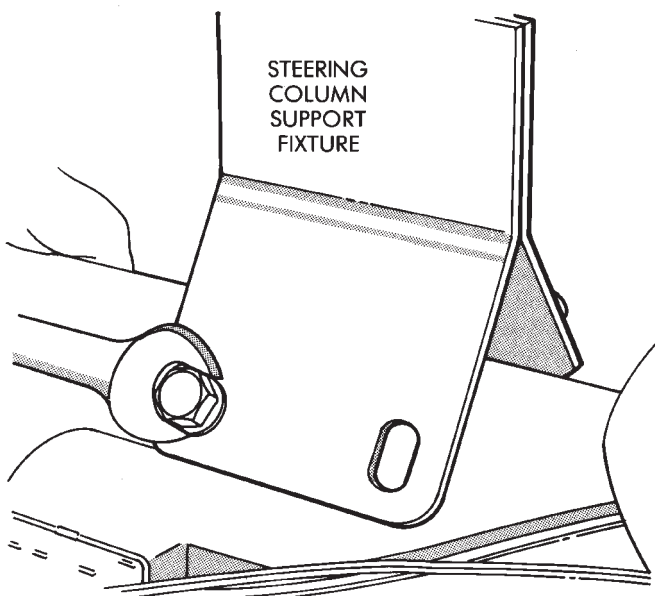

J8919-119

Fig. 1 Steering Column Support Fixture

(2) Remove the steering wheel. Refer to the removal procedure.

(3) Remove the lockplate cover.

WARNING: THE LOCKPLATE RETAINS A VERY STRONG, SPRING FORCE. DO NOT ATTEMPT TO

REMOVE THE STEERING SHAFT RETAINING SNAP RING WITHOUT USING LOCKPLATE COMPRESSOR C-4156.

(4) Compress the lockplate with Compressor C-4156 and release the steering shaft retaining snap ring (Fig. 2).

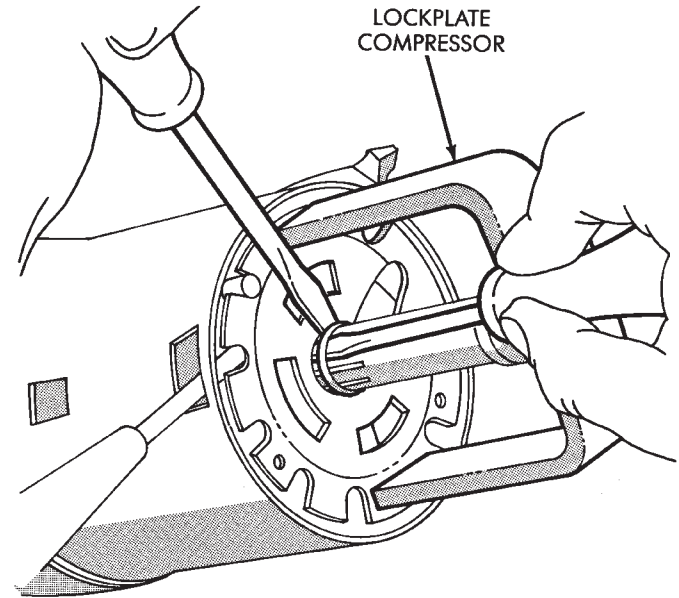

J8919-120

Fig. 2 Retaining Snap Ring Removal

(5) Remove the lockplate compressor tool and the retaining snap ring. Discard the snap ring.

CAUTION: When the steering shaft retaining snap ring is removed, the steering shaft is no longer retained within the column.

(6) Remove the lockplate, canceling cam, upper bearing preload spring, and the thrust washer from the steering column/shaft (Fig. 3).

(7) Remove the hazard warning switch knob. Press the knob inward and remove it from the column by turning it counterclockwise.

(8) Remove the turn signal/wiper/cruise control stalk by pulling it out straight from the column. Wiper must be in the off position.

(9) Disconnect the turn signal wire harness connector from the bracket.

CAUTION: Wrap tape around the turn signal switch wire harness connector (Fig. 4) to prevent it from becoming entangled during removal.

(10) Remove the turn signal switch retaining screws (Fig. 5), dimmer switch actuator arm, to remove the switch. Guide the switch straight up and out of the steering column.

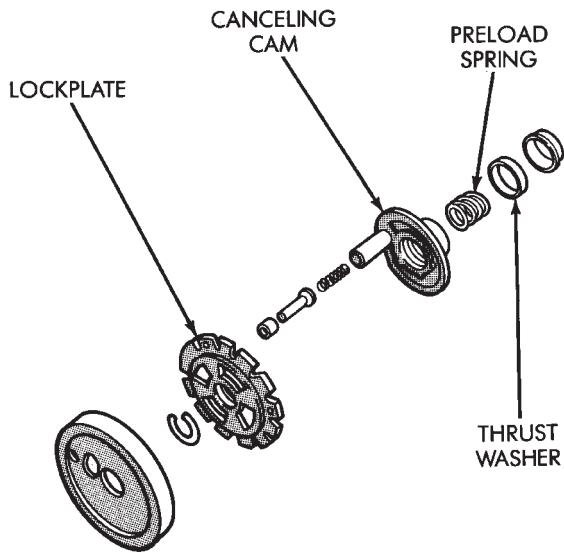

J8919-121

Fig. 3 Steering Column Disassembly

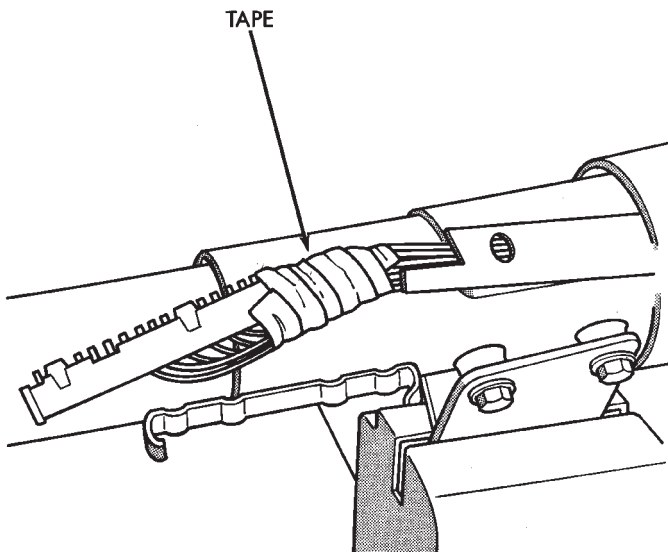

J8919-122

Fig. 4 Taped Turn Signal Switch Wire Harness Connector

(11) Remove the wiper switch wire harness and all the other wire harnesses located within the steering column.

(12) Insert the ignition switch key into the key/lock cylinder and turn to the ON position.

CAUTION: Do not attempt to remove the key warning buzzer switch and contacts separately. If separated, the contacts can detach and drop into the steering column.

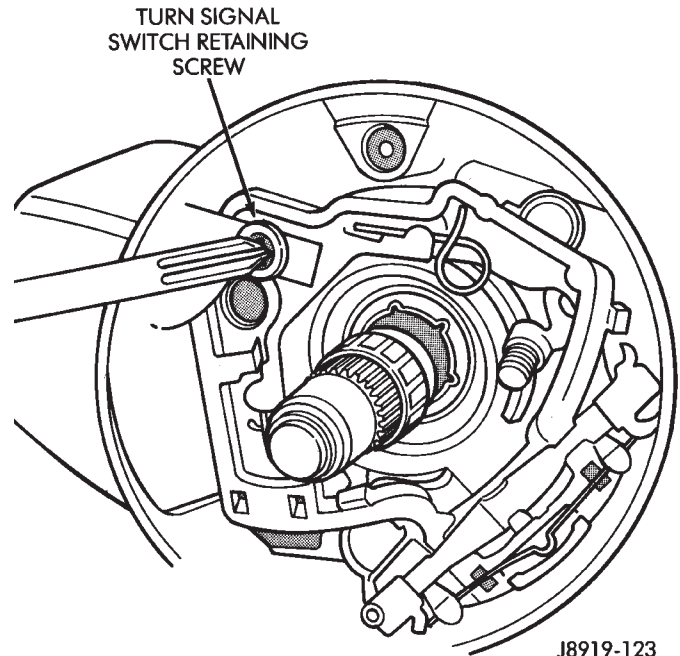

J8919-123

Fig. 5 Turn Signal Switch Retaining Screw

(13) Remove the key warning buzzer switch and contacts as a unit (Fig. 6). Use needle-nose pliers or a paper clip bent at a right angle (90 degrees).

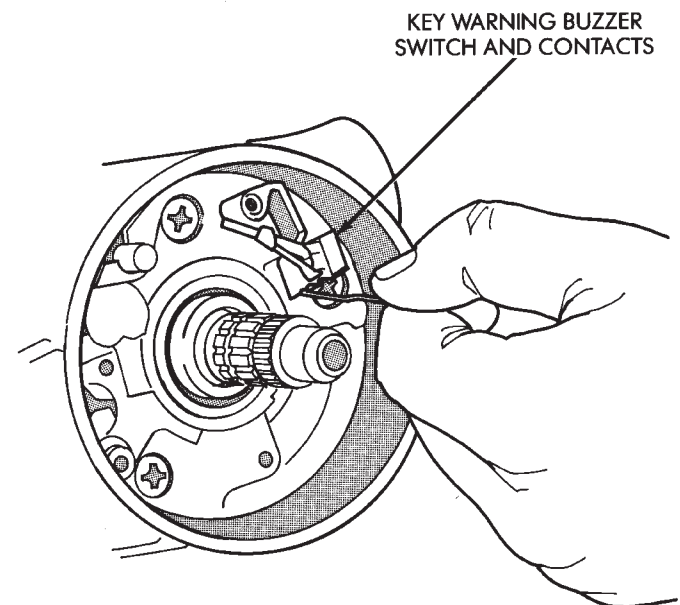

J8919-124

Fig. 6 Key Warning Buzzer/Contacts Removal

(14) Turn ignition key/lock cylinder to the ON position. Insert a thin screwdriver into the slot adjacent to the switch attaching screw boss (right-hand slot). Depress the spring latch located at the bottom of the slot to release the key/lock cylinder. Remove the key/lock cylinder. (Fig. 7).

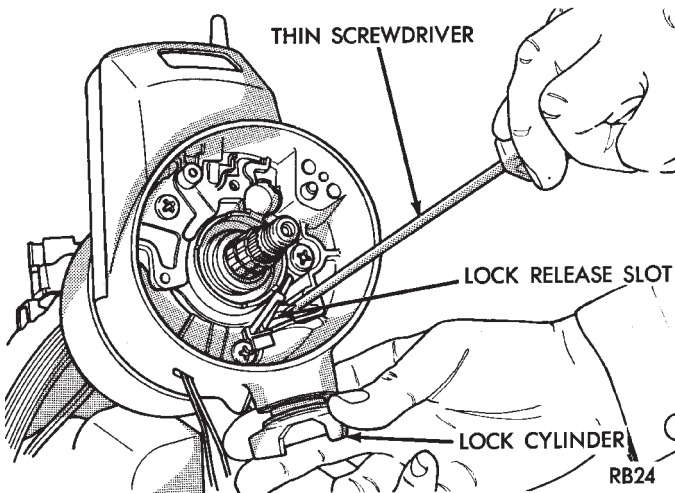

Fig. 7 Key/lock Cylinder Removal

(15) Remove the ignition switch and the dimmer switch (Fig. 8) from the lower end of the steering column.

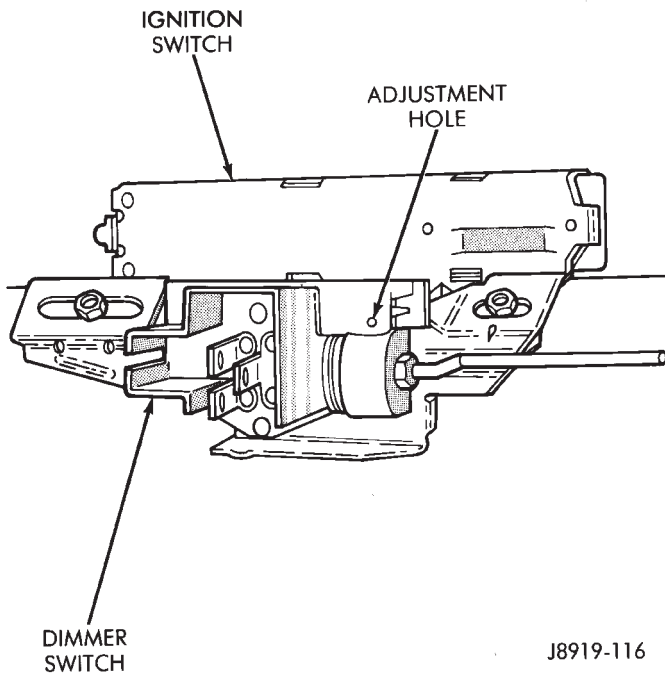

Fig. 8 Ignition Switch & Dimmer Switch

Proceed to Column Shift Disassembly Procedure or Console Shift Disassembly Procedure.

COLUMN SHIFT DISASSEMBLY

- (1) Remove the gear selector lever upper pivot pin and the selector lever.
- (2) Remove the upper bearing thrust washer.
- (3) Remove the four screws that attach the key/lock cylinder housing to the steering column jacket. Remove the housing (Fig. 9).
- (4) Remove the thrust cap from the key/lock cylinder housing (Fig. 10).

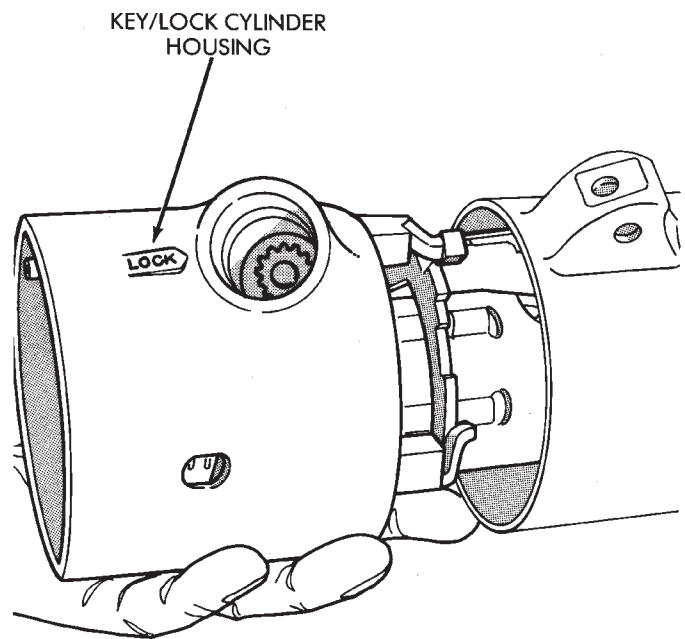

Fig. 9 Key/lock Cylinder Housing

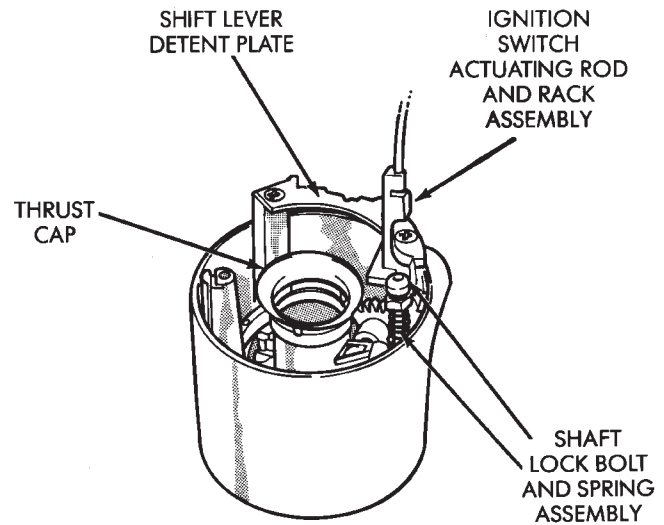
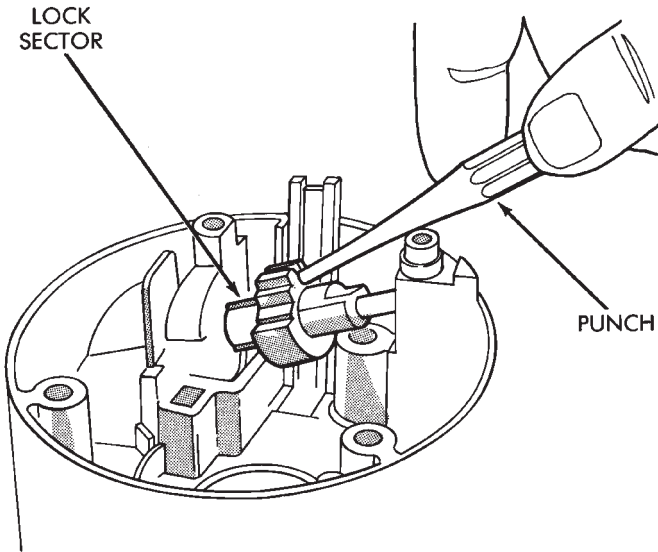

Fig. 10 Key/lock Cylinder Housing Components

- (5) Remove the ignition switch actuating rod and rack from the key/lock cylinder housing (Fig. 10).
- (6) Remove the rack preload spring and the shaft lock bolt and spring from the key/lock cylinder housing. Remove the shift lever detent plate from the housing (Fig. 10).
- (7) Use a blunt punch to exert force on the block tooth to disengage and remove the lock sector (Fig. 11).
- (8) Remove the gear selector lever housing and the shroud from the steering column jacket.



J8919-128

Fig. 11 Lock Sector Removal

(9) Remove the gear selector lever spring from the lever housing.

The steering column must be removed from the vehicle to disassemble the remaining steering column components.

(10) Remove the steering shaft (if not previously removed).

(11) Remove the spring clip from the steering column lower bearing retainer. Remove the retainer, the lower bearing and the adapter (Fig. 12).

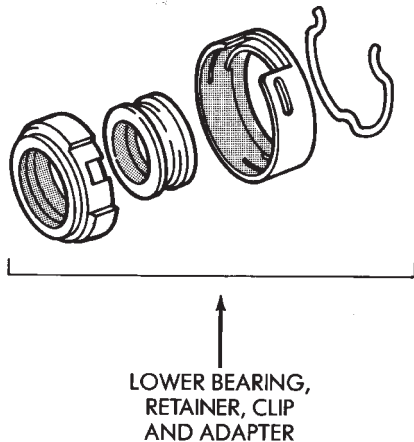

J8919-129

Fig. 12 Lower Bearing, Adapter, Retainer & Clip

(12) Slide out and remove the shift tube.

ASSEMBLY

WARNING: USE ONLY THE ORIGINAL OR EXACT REPLACEMENT SCREWS, BOLTS AND NUTS TO ASSEMBLE THE STEERING COLUMN. INCORRECT SCREW OR BOLT LENGTH COULD PREVENT THE COLUMN FROM COMPRESSING WITH IMPACT (FRONT-END COLLISION). ALL FASTENERS USED FOR ASSEMBLY MUST BE TIGHTENED WITH THE CORRECT TORQUE. THIS WILL ENSURE THE COLUMN WILL BREAKAWAY WITH IMPACT.

CAUTION: Apply chassis lubricant to all the bearing, thrust and friction producing mating surfaces before assembly.

COLUMN SHIFT ASSEMBLY

(1) Insert the lock sector through the key/lock cylinder hole in the key/lock cylinder housing. Install the lock sector on the lock sector shaft (Fig. 13). Ensure that the lock sector turns freely after installation.

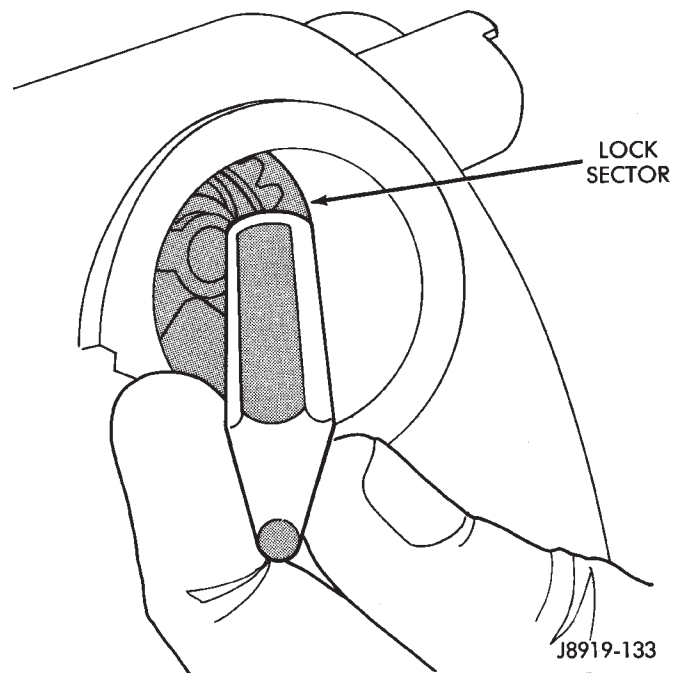

Fig. 13 Lock Sector Installation

(2) Install the lock rack preload spring. The bowed side of the spring must contact the lock rack when the rack is installed.

(3) Assemble the lock bolt and the lock rack (Fig. 14).

(4) Install the assembled lock bolt and lock rack in the key/lock cylinder housing (Fig. 15). Mate the lock rack block tooth with the lock sector block tooth.

(5) Install the shift lever detent plate on the key/lock cylinder housing (Fig. 16).

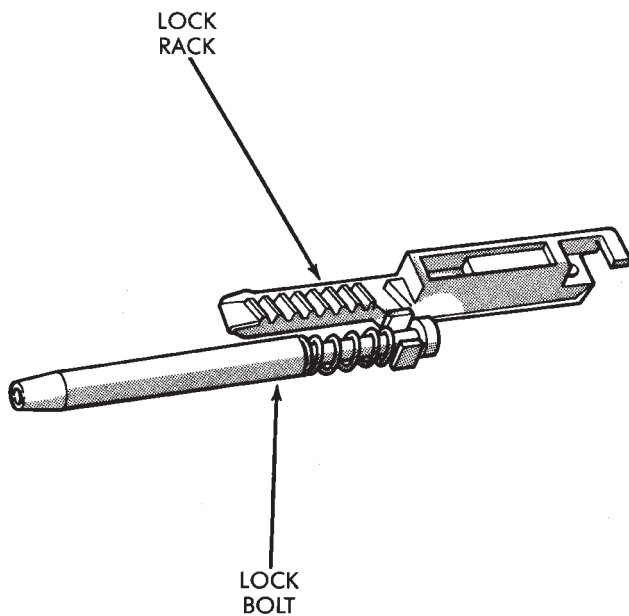

J8919-134

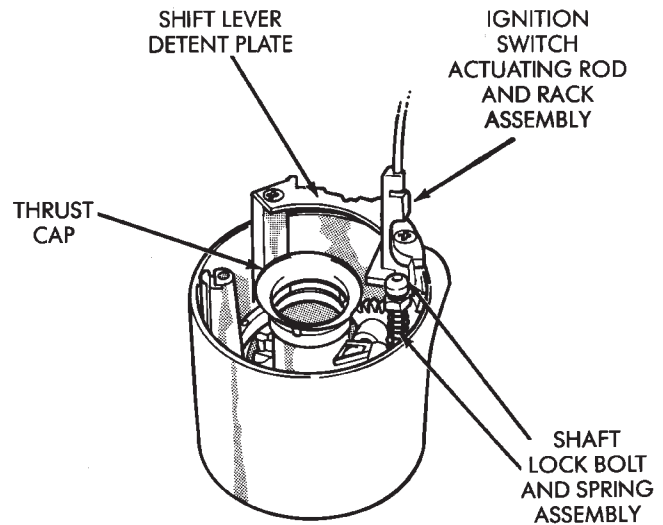
Fig. 14 Lock Bolt & Lock Rack

J8919-127

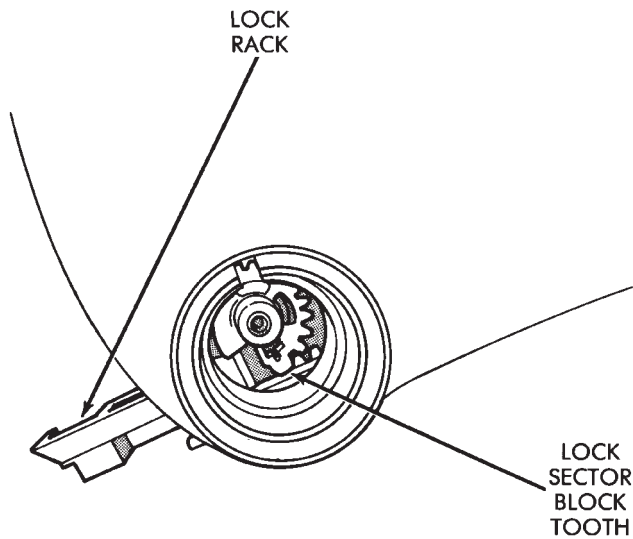
Fig. 16 Key/Lock Cylinder Housing

J8919-135

Fig. 15 Lock Bolt/Lock Rack Installation

(6) Install the thrust cap on the key/lock cylinder housing (Fig. 16).

(7) Install the ignition switch actuating rod and rack on the key/lock cylinder housing.

(8) Insert and install the gear selector lever housing lower bearing the housing. Align the indentations in the bearing shell with the projections on the housing jacket.

(9) Install the gear selector lever spring in the lever housing.

(10) Install the gear selector lever housing and shroud on the upper end of the steering column jacket. Rotate the housing and ensure that the bearing is properly seated.

(11) Place the gear selector in the PARK position, and the lock rack pulled downward. Position and correctly seat the key/lock cylinder housing on the steering column jacket. Install and tighten the four attaching screws.

(12) Insert the shift tube in the lower end of the steering column jacket. Rotate it until the shift tube upper key slides into the gear selector housing key-way.

COLUMN SHIFT FINAL ASSEMBLY

(1) To install ignition switch lock, turn the key to the LOCK position and remove the key. This will cause the buzzer operating lever to retract in the key/lock cylinder. Now insert the key/lock cylinder into the housing far enough to contact the drive shaft (Fig. 17). Force it inward and move the ignition switch actuator rod up and down to align the components. When the components align, the key/lock cylinder will move inward and lock in place.

(2) Install the key warning buzzer switch.

(3) Install the ignition switch, refer to Ignition Switch —All Models in Group 8D, Ignition.

(4) Install the lower bearing, the adapter, the retainer and spring clip at the lower end of the steering column.

(5) Install the steering shaft through the lower end of the steering column and insert it into the upper bearing.

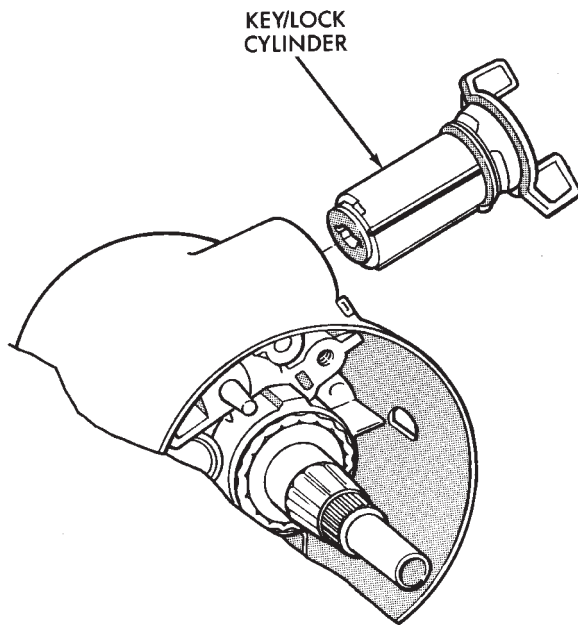

J9119-35

Fig. 17 Key/Lock Cylinder Installation

(6) Position the turn signal switch and wire harness in the cylinder housing. Fold the wires against the connector. Route the connector down through the steering column jacket.

(7) Install the windshield wiper wire harness and switch. Route the wire harness down through steering column jacket.

(8) Align the turn signal switch in the housing and secure the switch with the attaching screws. Tighten the screws to 4 N·m (35 in. lbs.) torque.

(9) Install the dimmer switch actuator arm. Tighten the attaching screws to 4 N·m (35 in. lbs.) torque.

(10) If equipped, install the cruise control wire harness. Install the turn signal stalk by pushing it straight into the column.

(11) Position the thrust washer, the upper bearing preload spring and the canceling cam on the steering shaft (Fig. 18).

(12) Place the turn signal switch in the neutral (OFF) position and install the hazard warning switch knob.

(13) Position the lockplate on the steering shaft. Install a replacement lockplate retaining snap ring on the sleeve of the Lock Plate Compressor C-4156. Install the tool on the steering shaft (Fig. 19).

(14) Compress the lockplate with the compressor tool and position the retaining snap ring in the steering shaft groove.

(15) Ensure that the retaining snap ring is completely seated in the groove before removing the tool. Remove the tool and install the lockplate cover.

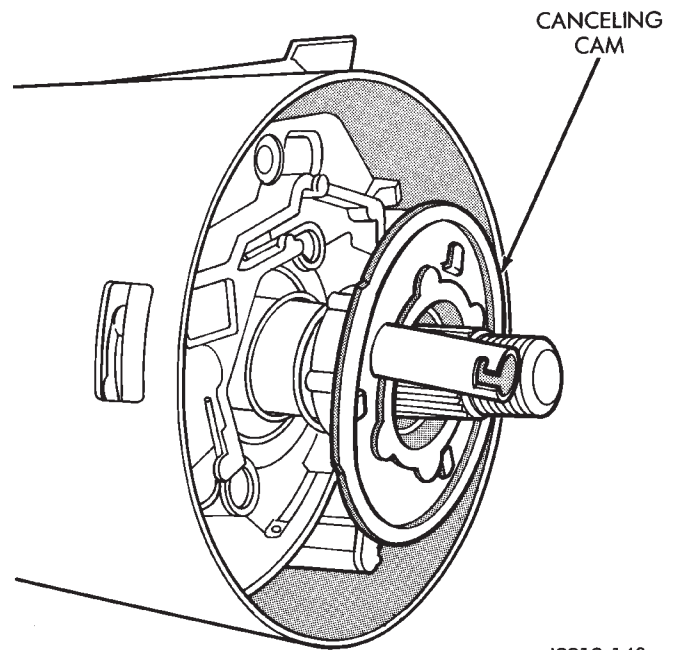

J8919-140

Fig. 18 Canceling Cam Position

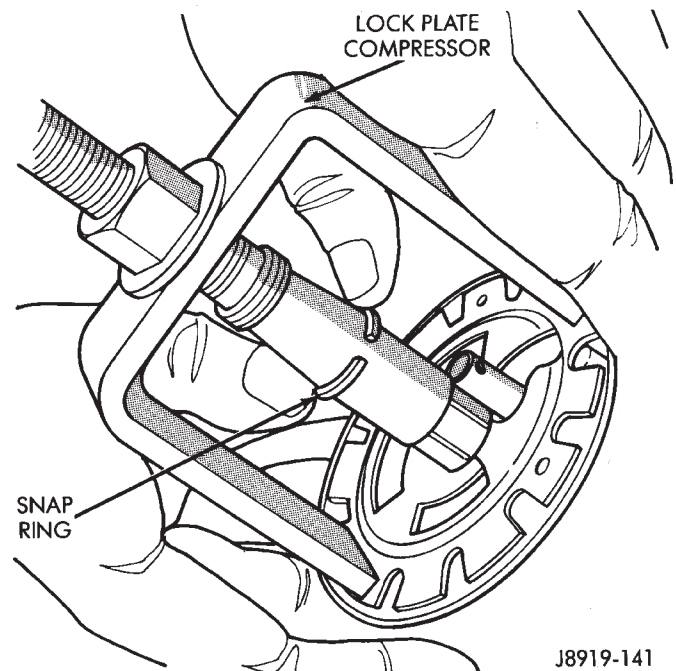

J8919-141

Fig. 19 Lockplate Snap Ring Installation

(16) Install the steering wheel. Refer to the installation procedure. Tighten the steering wheel retaining nut to 34 N·m (25 ft. lbs.) torque.

(17) If removed, install the steering column in the vehicle. Refer to the installation procedure.

(18) If disconnected, connect the battery negative cable and, if equipped, reset the clock

TILT STEERING COLUMN

DISASSEMBLY

- (1) Remove the steering column from the vehicle, if necessary. Refer to the removal procedure.
- (2) If the column is removed for service, fabricate a support fixture to clamp it in a vise (Fig. 1).

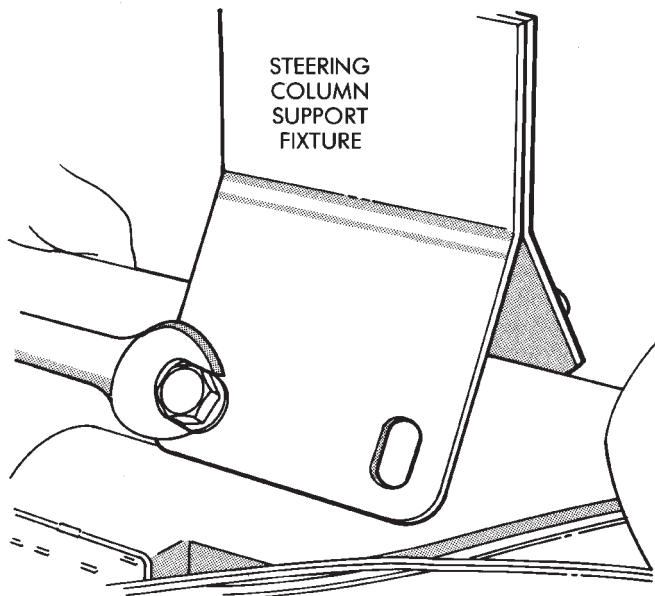

J8919-119

Fig. 1 Steering Column Support Fixture

- (3) If the steering column has not been removed from the vehicle, place the front wheels in the straight-ahead position. Disconnect the battery negative cable.
- (4) Protect the painted areas on the steering column.
- (5) Remove the steering wheel. Refer to the removal procedure.
- (6) Column shift: Remove the gear selector lever retaining pin and the lever from the housing.
- (7) Remove the lockplate cover. Use two small pry bars to pry the cover off the lockplate.

WARNING: THE LOCKPLATE RETAINS A VERY STRONG, SPRING FORCE. DO NOT ATTEMPT TO REMOVE THE STEERING SHAFT RETAINING SNAP RING WITHOUT USING LOCKPLATE COMPRESSOR C-4156.

- (8) Compress the lockplate with Lock Plate Compressor C-4156 and release the steering shaft retaining snap ring (Fig. 2).
- (9) Remove the lockplate compressor tool and the retaining snap ring. Discard the snap ring.
- (10) Remove the lockplate, canceling cam, upper bearing preload spring, and the thrust washer from the steering column/shaft.

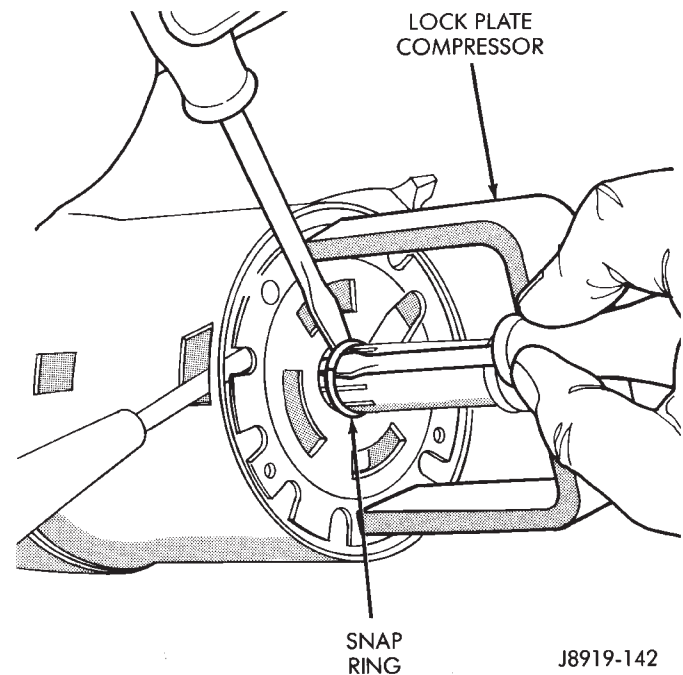

J8919-142

Fig. 2 Lockplate Snap Ring Removal

- (11) Remove the hazard warning switch knob. Press the knob inward and remove it from the steering column by turning it counterclockwise.
- (12) If the steering column is the column shift type, remove the two retaining screws and the gear selector indicator cover.
- (13) If the steering column is the column shift type, remove the gear selector indicator lamp bracket retaining screw. Do not remove the lamp and bracket at this time.
- (14) Remove the tilt-release lever.
- (15) Disconnect the turn signal wire harness connector from the bracket located at the lower end of the steering column (Fig. 3).

CAUTION: Wrap tape around the turn signal switch wire harness connector to prevent it from becoming entangled during removal.

- (16) Remove the plastic protector from the wire harness.
- (17) Remove the turn signal switch retaining screws (Fig. 4), dimmer switch actuator arm, to remove the switch. Guide the switch straight up and out of the steering column.
- (18) Remove the windshield wiper switch wire harness and all the other wire harnesses located within the steering column.
- (19) Insert the ignition switch key into the key/lock cylinder. Turn the key to the ON position.

CAUTION: Do not attempt to remove the key warning buzzer switch and contacts separately. If separated, the contacts can detach and drop into the steering column.

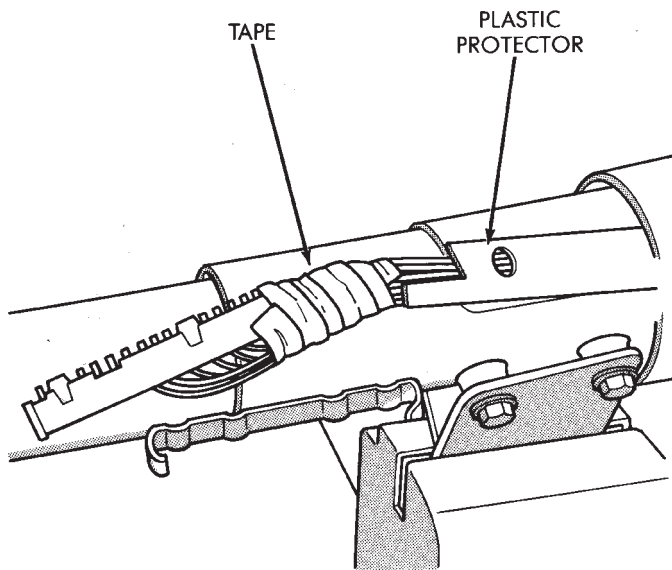

J8919-143

Fig. 3 Turn Signal Switch Wire Harness Connector

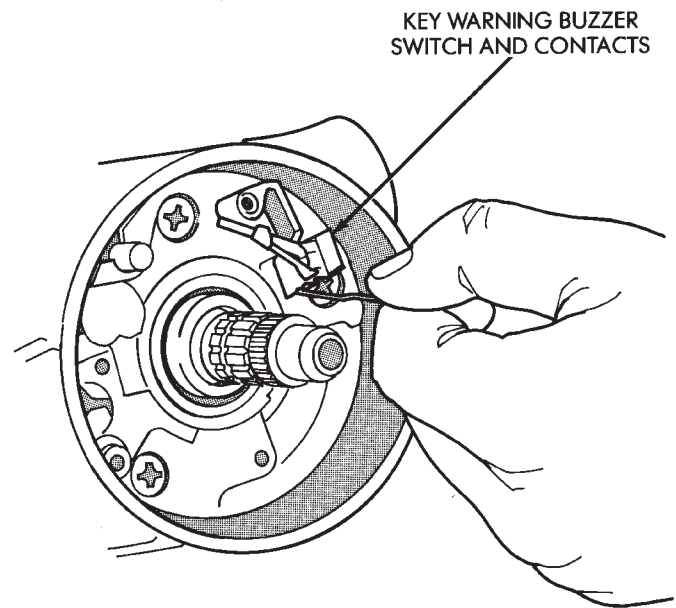

J8919-124

Fig. 5 Key Warning Buzzer/Contacts Removal

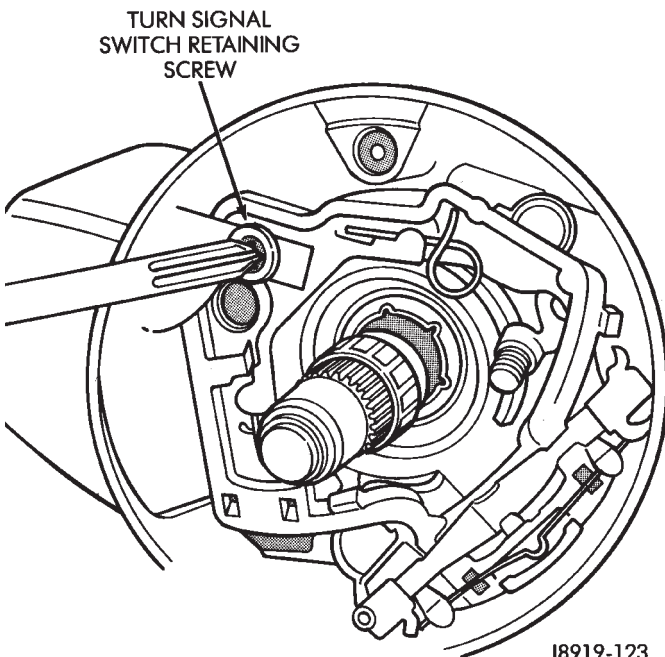

J8919-123

Fig. 4 Turn Signal Switch Removal

(20) Remove the key warning buzzer switch and contacts as a unit (Fig. 5). Use needle-nose pliers or a paper clip bent at a right angle (90 degrees).

(21) Turn ignition key/lock cylinder to the ON position. Insert a thin screwdriver into the slot adjacent to the switch attaching screw boss (right-hand slot). Depress the spring latch located at the bottom of the slot to release the key/lock cylinder. Remove the cylinder (Fig. 6).

(22) Remove the ignition switch and dimmer switch (Fig. 7) from the lower end of the steering column.

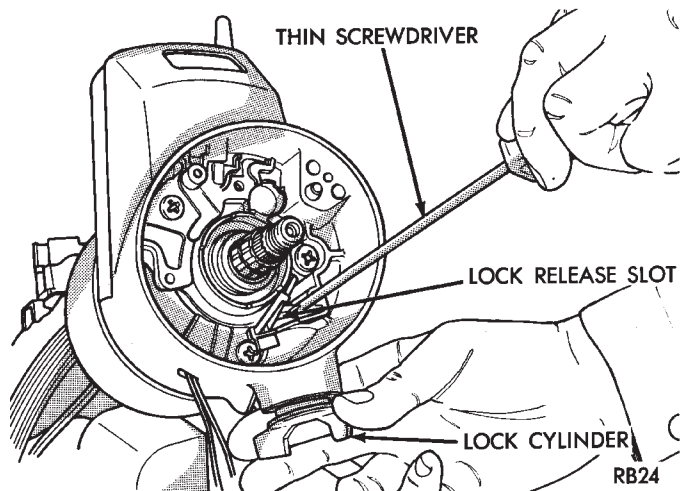

Fig. 6 Key/lock Cylinder Removal

(23) Remove the screws that attach the key/lock cylinder housing cover to the steering column jacket. Remove the cover.

(24) Remove the upper bearing race and the bearing seat from the steering shaft (Fig. 8).

(25) Install the tilt-release lever and place the steering column in the full upward tilt position.

WARNING: THE TILT SPRING GUIDE RETAINER RETAINS STRONG SPRING FORCE.

(26) Press the tilt spring guide retainer inward. Turn it counterclockwise until the tabs disengage from the key/lock cylinder housing lugs. Ensure that the screwdriver blade properly fits the retainer slot. Remove the tilt spring guide retainer, the guide and the spring from the housing (Fig. 9).

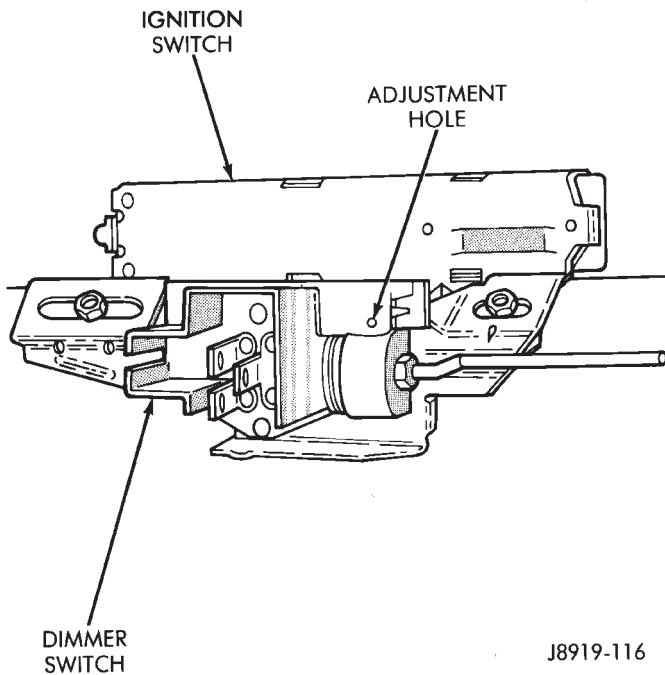

Fig. 7 Ignition Switch & Dimmer Switch

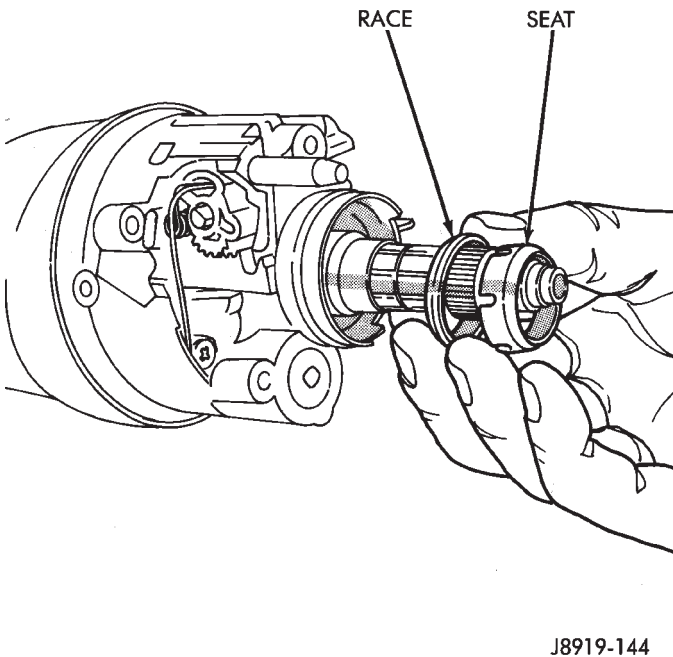

Fig. 8 Steering Shaft Bearing Race & Seat

(27) Position the steering column in the center, non-tilt position.

(28) Remove the support pivot pins with Pivot Pin Remover C-4016 (Fig. 10).

(29) Lift the tilt-release lever to release the lock shoes. Pull the key/lock cylinder housing upward to disengage the shoes. Turn the housing clockwise to separate the lock rack from the remote rod. Remove the cylinder housing from the support (Fig. 11).

(30) Remove the tilt-release lever from the key/lock cylinder housing.

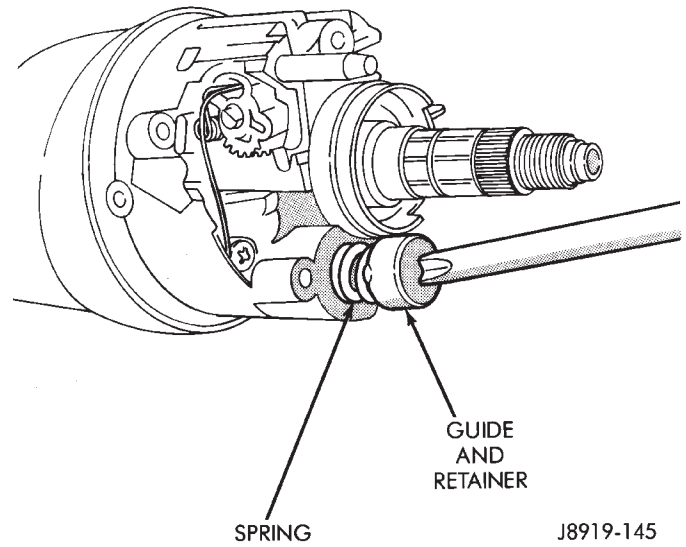

Fig. 9 Retainer/Guide/Spring Removal

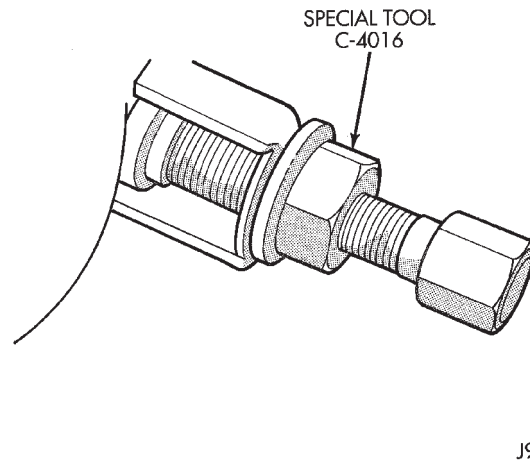

Fig. 10 Pivot Pin Removal

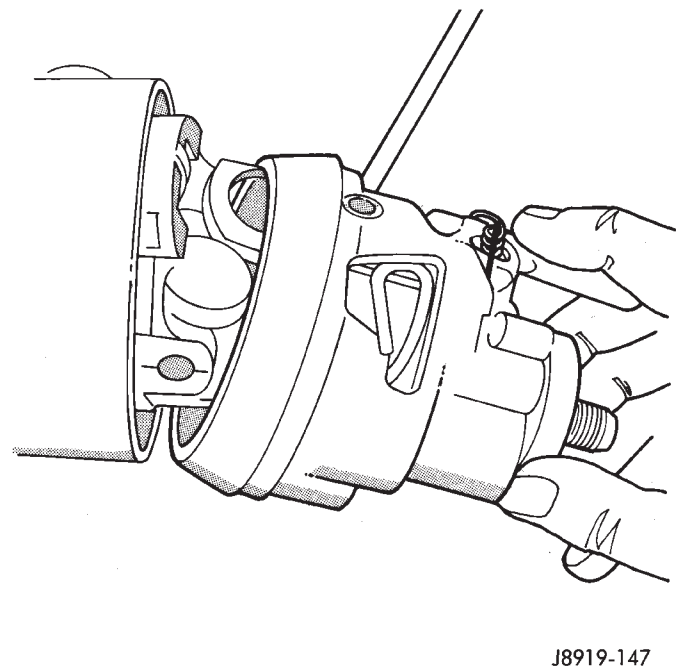

Fig. 11 Key/Lock Cylinder Housing Removal

(31) Remove the lock sector spring retaining screw and then remove the spring (Fig. 12). Rotate the spring in a clockwise direction to remove it from the lock bolt.

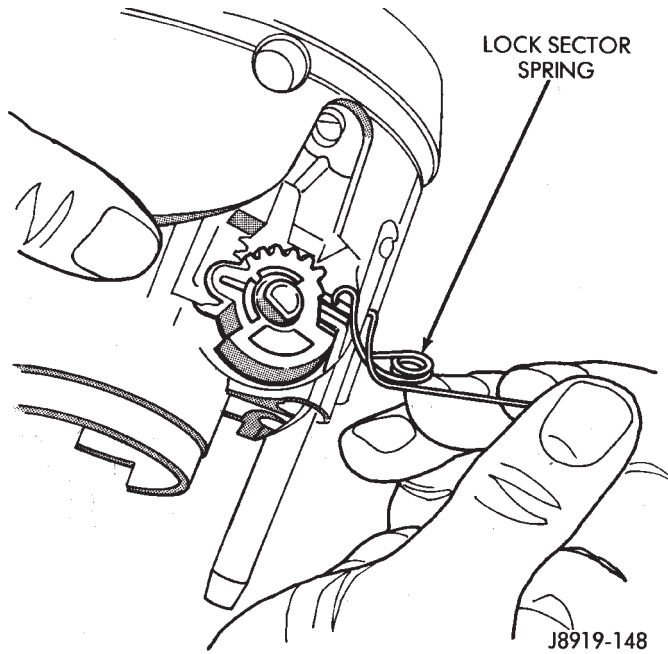

Fig. 12 Lock Sector Spring Removal

(32) Remove the lock bolt, the lock rack, the rack preload spring and the remote rod from the cylinder housing.

(33) Insert a wedge between the lock shoes and the key/lock cylinder housing (Fig. 13). This will relieve spring tension on the tilt-release lever pin and lock shoe pin.

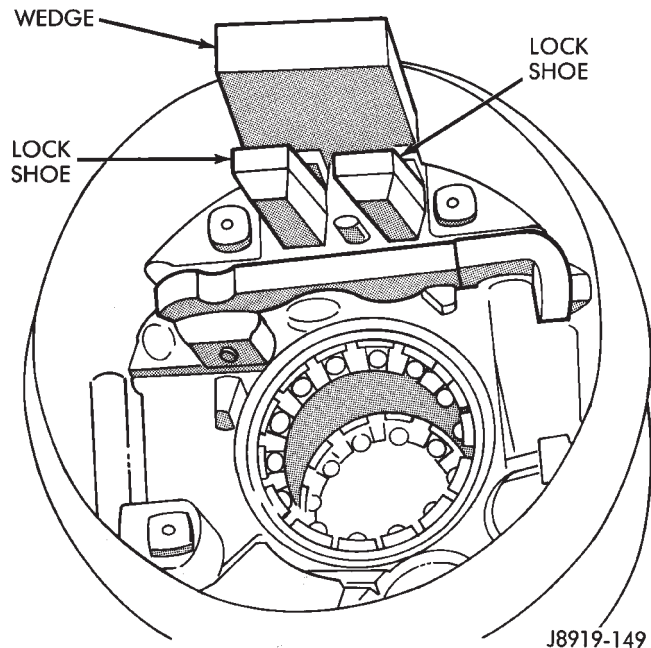

Fig. 13 Wedge Between Lock Shoes & Housing

(34) Remove the tilt-release lever pin from the key/lock cylinder housing with a standard pin punch (Fig. 14).

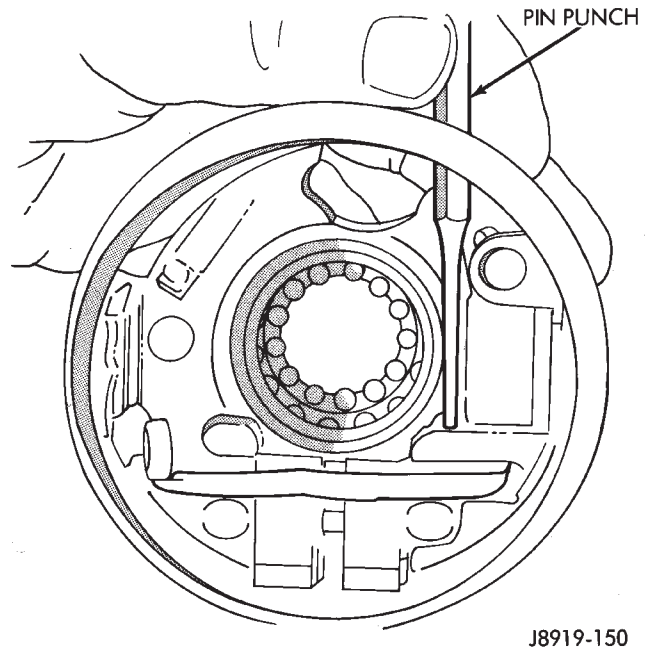

Fig. 14 Tilt-release Lever Pin Removal

(35) Remove the lock shoe pin from the key/lock cylinder housing with a standard pin punch (Fig. 15). Remove the lock shoes, the springs and wedge.

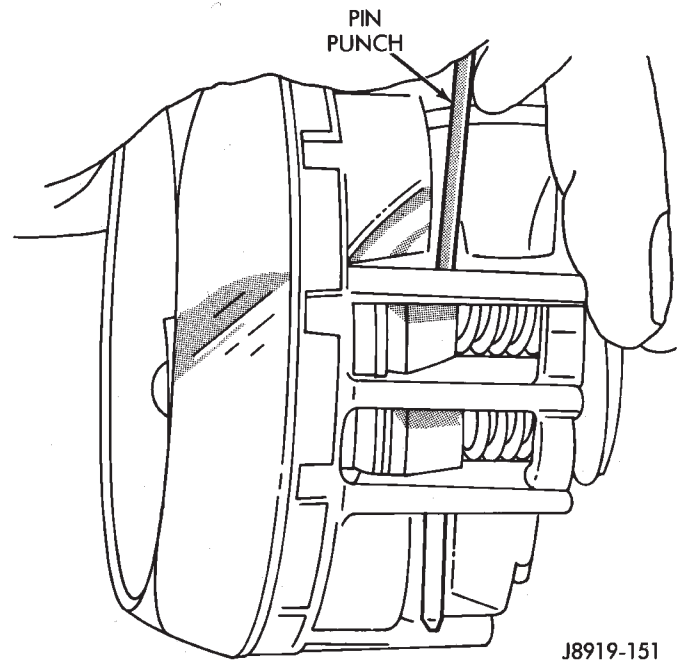

Fig. 15 Lock Shoe Pin Removal

(36) Remove the upper and the lower bearings and races from the key/lock cylinder only if they are damaged or worn. If the bearings and the races must be

replaced, remove them with a hammer and punch. Discard the bearings and races after removal. They are not reusable.

(37) Remove the steering shaft from the upper end of the steering column.

(38) Separate the steering shaft by folding it 90 degrees at the flexible joint. Detach the upper and the lower shaft halves (Fig. 16).

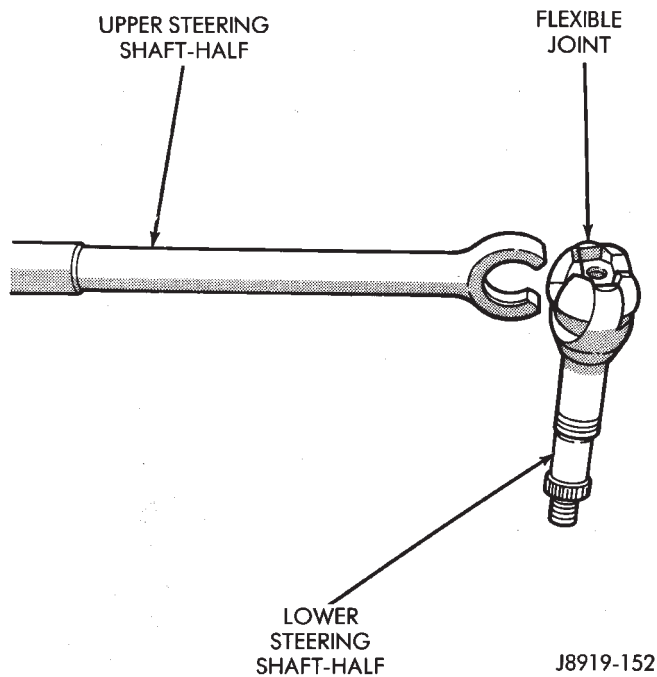

Fig. 16 Steering Shaft Separation

(39) Remove the attaching bolts and the steering column support (Fig. 17).

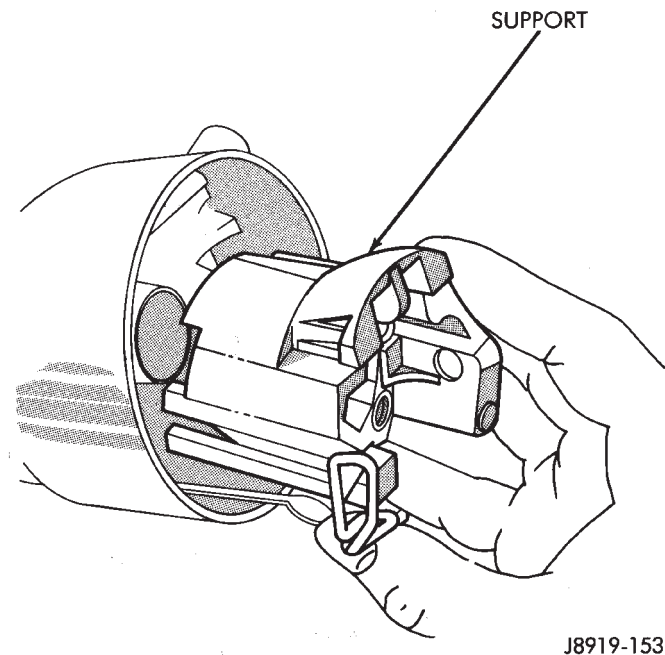

Fig. 17 Steering Column Support Removal

(40) Remove the retaining screws and shift gate from the steering column support.

(41) Remove the retainer and the bearing from the lower end of the steering column.

(42) Remove the shift tube retaining ring and the thrust washer.

(43) Remove the shift tube from the steering column jacket with Shift Tube Remover C-4120 (Fig. 18).

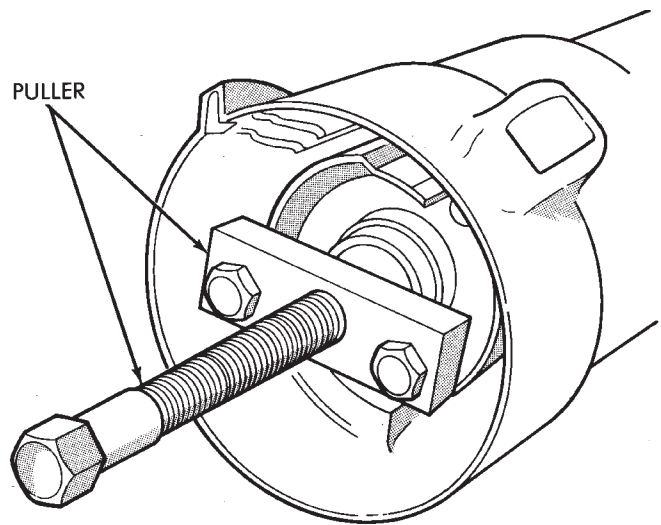

Fig. 18 Shift Tube Removal

(44) Tilt the upper end of the retainer plate toward the lower end of the column, turn the plate counter-clockwise and remove it (Fig. 19).

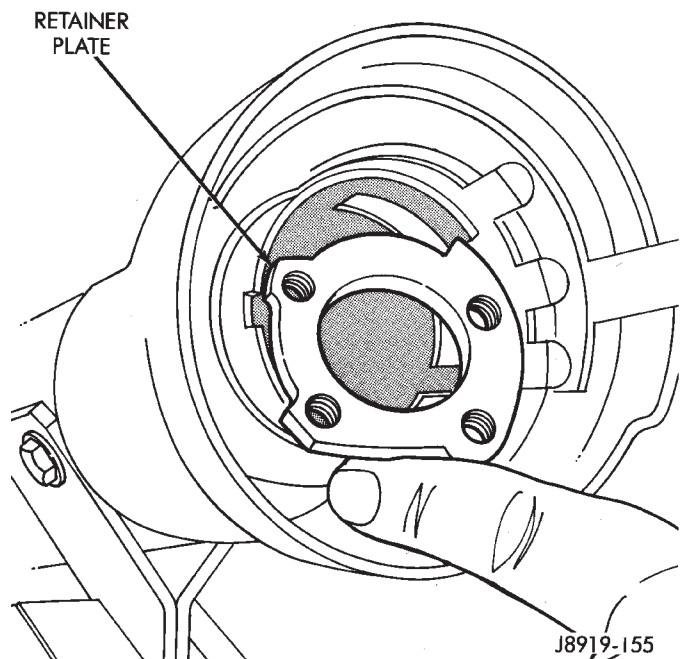

Fig. 19 Retainer Plate Removal

(45) If equipped with a column shift:

- Remove the wave washer and the shift tube spring
- Remove the shift bowl from the steering column jacket

(46) If equipped with a console shift, remove the key-release lever and the lever spring from the shroud. Tilt the lever forward and lift upward to remove it (Fig. 20).

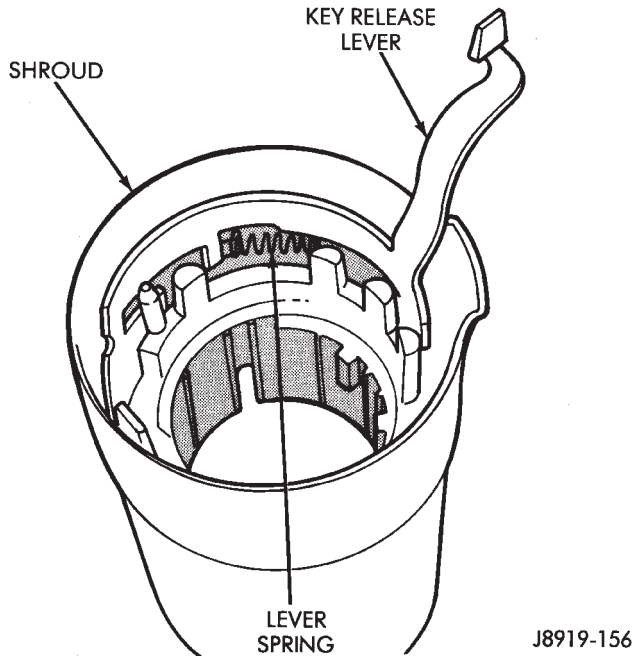

Fig. 20 Key-Release Lever & Spring Removal

ASSEMBLY

WARNING: USE ONLY THE ORIGINAL OR EXACT REPLACEMENT SCREWS, BOLTS AND NUTS TO ASSEMBLE THE STEERING COLUMN. INCORRECT SCREW OR BOLT LENGTH COULD PREVENT THE COLUMN FROM COMPRESSING WITH IMPACT (FRONT-END COLLISION). ALL FASTENERS USED FOR ASSEMBLY MUST BE TIGHTENED WITH THE CORRECT TORQUE. THIS WILL ENSURE THE COLUMN WILL BREAKAWAY WITH IMPACT.

CAUTION: Apply chassis lubricant to all the bearing, thrust and friction producing mating surfaces before assembly.

(1) Install the shift bowl on the steering column jacket.

(2) Install the shift tube spring, wave washer and retainer plate in the shift bowl.

(3) Insert the shift tube through the lower end of the steering column jacket. Align the tube key/spline with the shift bowl keyway.

(4) Insert the Shift Tube Installer C-4119 in the shift tube. The spring-loaded lower foot of the tool

must engage the shift tube inner shoulder. The tool guide must be seated in the shift tube (Fig. 21).

(5) Tighten the nut on the stud (Fig. 21) only enough to obtain a snug fit against the spring tension.

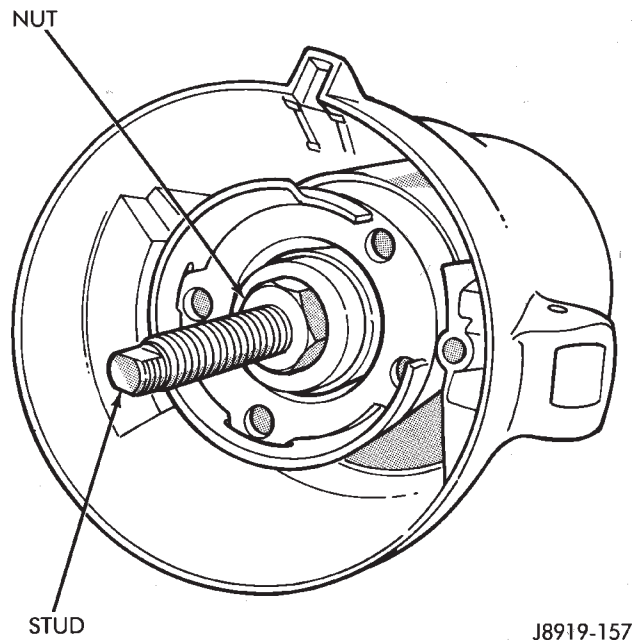

Fig. 21 Shift Tube Installation

(6) Remove the nut and place the receiver installation tool over the stud (Fig. 22).

(7) Install the nut and tighten it to force the shift tube into the shift bowl (Fig. 22).

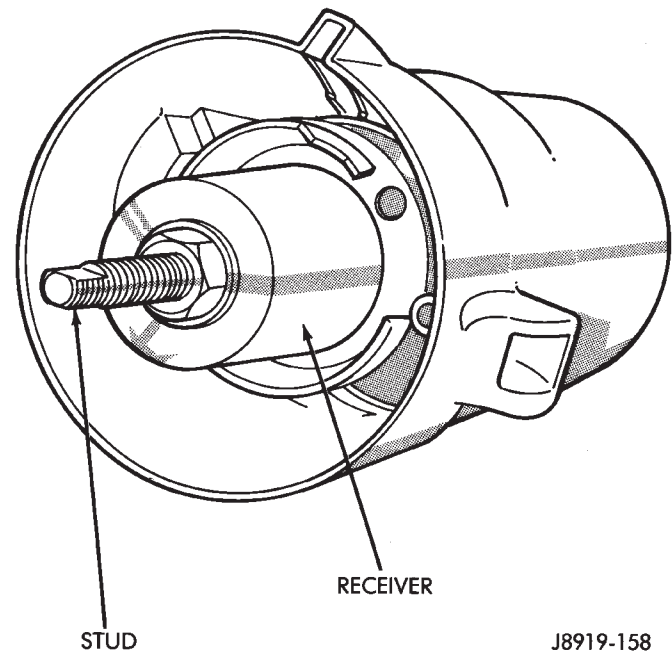

Fig. 22 Shift Tube Installation

(8) Remove the shift tube installation tools.

(9) Install the shift tube thrust washer and the retainer plate snap ring.

(10) Install the lower bearing in the steering column.

(11) Position the shift gate in the steering column support. Install the attaching screws.

(12) Position the support in the steering column.

(13) Install all support attaching screws finger-tight. Next, tighten the screws alternately and evenly to 7 N·m (60 in. lbs.) torque.

(14) Install the remote rod in the support. Route the rod through the upper end of the shroud and insert it into the rod slot located in the support.

(15) Install the dimmer switch and ignition switch.

(16) Install the steering shaft in the steering column.

(17) Install replacement races and bearings in the key/lock cylinder, if removed. **Ensure that the bearings are lubricated with chassis lubricant before installation.**

(18) Install the lock shoes, the lock shoe springs and the lock shoe pin in the key/lock cylinder housing. Use a 4.5-mm (0.18-in) diameter rod to align the shoes and the pin during installation.

(19) Install the tilt-release lever, the lever spring and the lever pin in the key/lock cylinder housing. Insert a wedge between the housing and the lever to relieve the spring tension. This will allow easier release lever pin installation.

(20) Install the lock bolt in the key/lock cylinder housing and engage it in the lock sector cam surface.

(21) Install the lock rack, the rack preload spring and a replacement shim in the key/lock cylinder housing. Align and mate the square block tooth on the lock rack and the lock sector.

(22) Install the lock spring and the spring retaining screw. Tighten the screw to 4 N·m (35 in. lbs.) torque.

(23) Align and install the assembled key/lock cylinder housing on the support. Retain the lock shoes in the disengaged position for easier housing installation.

(24) Align the pivot pin holes in the housing with those in the support. Insert the pivot pins. **Press the housing firmly downward when inserting the pivot pins. This prevents damaging the holes in the support.** When the pivot pins are within both the housing and the support holes, seat them fully with a punch and a hammer.

(25) Insert tilt-release lever in key/lock cylinder housing and place housing in the full-upward tilt position.

(26) Lubricate the tilt spring guide and the tilt spring liberally with chassis lubricant and position the spring on the guide.

(27) Insert the tilt spring guide and the spring into the key/lock cylinder housing. Install the guide re-

tainer over the spring. Engage the retainer lock tabs with the housing lugs by pressing the retainer downward and turning clockwise with a screwdriver.

(28) Place the cover on the key/lock cylinder housing. Align and install the cover retaining screws. Tighten the screws to 7 N·m (60 in. lbs.) torque.

(29) Install the gear selector indicator lamp mounting bracket screw.

(30) Install the gear selector indicator cover and retaining screws.

(31) Route the dimmer switch wire harness and gear selector indicator down through the steering column.

(32) To install ignition switch lock, turn the key to the LOCK position and remove the key. This will cause the buzzer operating lever to retract in the key/lock cylinder. Now insert the key/lock cylinder into the housing far enough to contact the drive shaft. Force it inward and move the ignition switch actuator rod up and down to align the components. When the components align, the key/lock cylinder will move inward and the spring-loaded retainer will snap and lock it in place (Fig. 23).

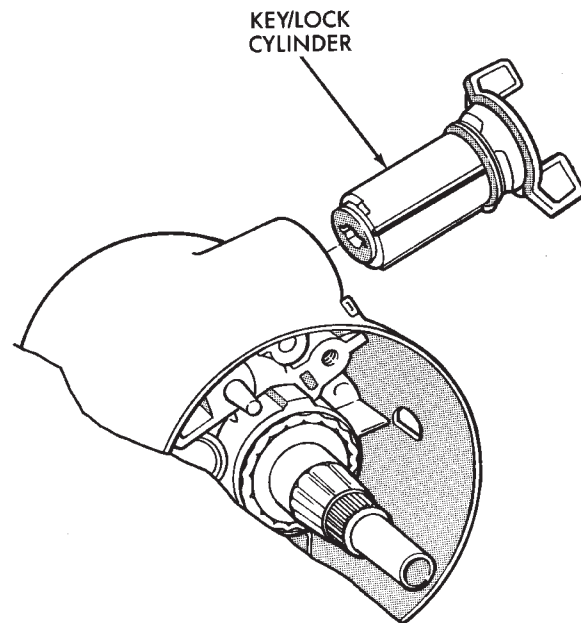

J9119-35

Fig. 23 Key/Lock Cylinder Installation

(33) Insert the ignition key in the cylinder and turn it to the ON position. Install the key warning buzzer switch.

(34) Install the turn signal switch. Fold the wires against the connector. Route the wire harness and connector down through the steering column. Position the switch in the key/lock cylinder housing. **Do not** install the switch retaining screws at this time.

(35) Install the windshield wiper wire harness and switch. Route the wire harness down through steering column jacket.

(36) If equipped, install the cruise control wire harness. Install the turn signal stalk by pushing it straight into the column.

(37) Insert the hazard warning knob in the hazard warning switch and press it inward. Align and install the turn signal switch retaining screws. Ensure that the turn signal switch is properly seated before tightening the screws. Tighten the screws to 4 N·m (33 in. lbs.) torque. Thread the hazard warning switch knob into the switch and pull the knob outward.

(38) Install and seat the upper bearing race in the key/lock cylinder housing.

(39) Install the upper bearing preload spring, the canceling cam and the lockplate.

(40) Install a replacement lockplate retaining snap ring on the sleeve of the Lock Plate Compressor C-4156. Install the tool on the steering shaft (Fig. 24).

(41) Compress the lockplate with the compressor tool and position the retaining snap ring in the steering shaft groove.

(42) Remove the compressor tool. Ensure that the retaining ring is completely seated in the groove before removing the tool.

(43) Position the wire harness protectors if equipped, over the harnesses and snap in place on steering column.

(44) Install the lockplate cover.

(45) Install the gear selector lever and the retaining pin.

(46) Install the steering wheel. Refer to the installation procedure.

(47) Insert the ignition key in the key/lock cylinder; turn the cylinder to the OFF-UNLOCK position; move the ignition switch downward to eliminate any switch-to-remote rod lash; and tighten the ignition switch attaching screws to 4 N·m (35 in. lbs.) torque.

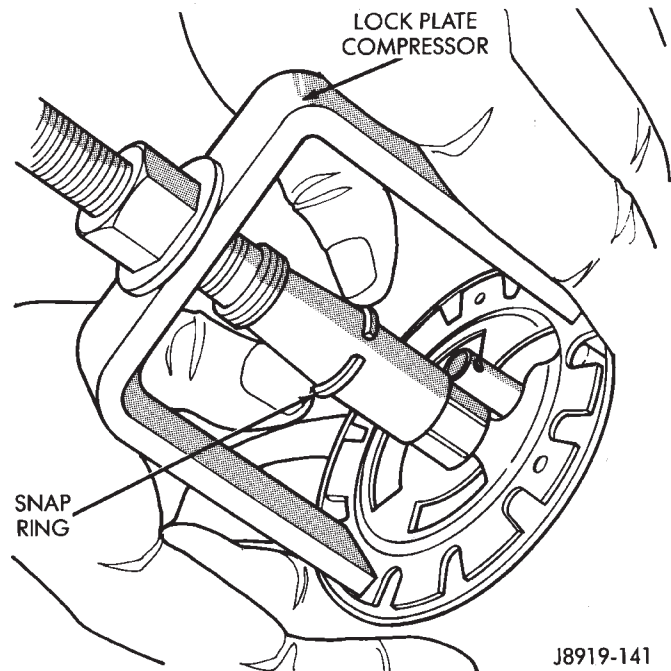

J8919-141

Fig. 24 Lockplate Retaining Ring Installation

(48) Depress the dimmer switch slightly and insert a 3/32-inch drill bit into the adjustment hole.

(49) Loosen the retaining screws and move the dimmer switch toward the steering wheel. Tighten the dimmer switch retaining screws to 4 N·m (35 in. lbs.) torque.

(50) Remove the drill bit and test operation by moving the dimmer switch stalk. Test the dimmer switch operation in the full-up, down and center steering wheel positions.

(51) Install the steering column, if applicable. Refer to the installation procedure.

STEERING RHD

GENERAL SERVICE PROCEDURE INFORMATION

Right hand drive service procedures and torque specifications involving steering; linkage, gear and column are the same as left hand drive vehicles except where shown. Refer to appropriate service procedures regarding each component in the system.

The steering linkage consists of a pitman arm, drag link, and tie rod. Adjustment sleeves are used on the tie rod and drag link for toe and steering wheel alignment (Fig. 1).

RECIRCULATING-BALL POWER STEERING GEARS

The steering gears can be adjusted and internally serviced. The components CANNOT be interchanged with those of a left hand drive vehicle.

The steering gear has a 17.5:1 ratio.

POWER STEERING PUMP

PRESSURE AND RETURN LINE REPLACEMENT

Cap hose open ends and pump/steering gear fittings to prevent entry of foreign material.

WARNING: POWER STEERING FLUID (AND PUMP COMPONENTS) AND THE EXHAUST SYSTEM CAN BE EXTREMELY HOT IF THE ENGINE HAS BEEN RECENTLY OPERATING. DO NOT START THE ENGINE WITH ANY LOOSE OR DISCONNECTED HOSES. DO NOT ALLOW THE LINES TO TOUCH A HOT EXHAUST MANIFOLD.

REMOVAL

- (1) Place a drain pan under the pump and gear.
- (2) Disconnect the pressure and return line from the steering gear (Fig. 2, 3).

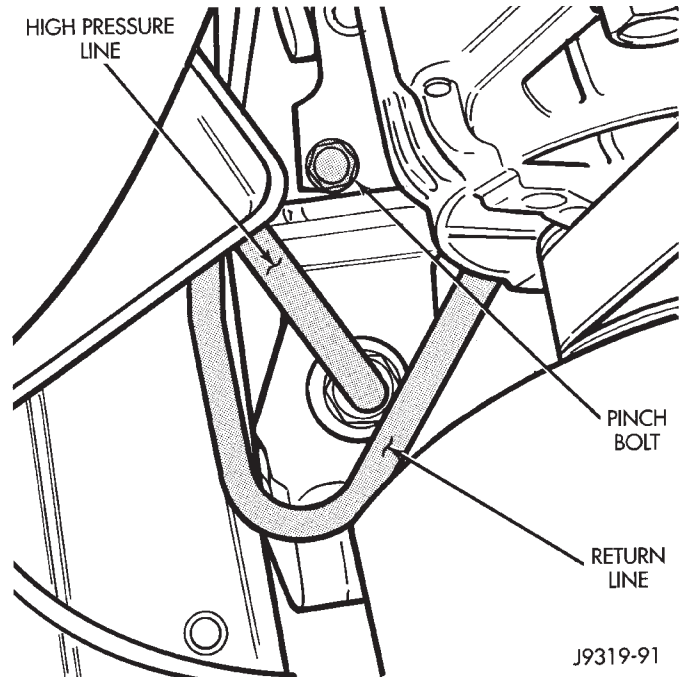

Fig. 2 Fluid Lines On Steering Gear

- (3) Disconnect the pressure and return line from the pump (Fig. 4). Drain the fluid from pump and reservoir.

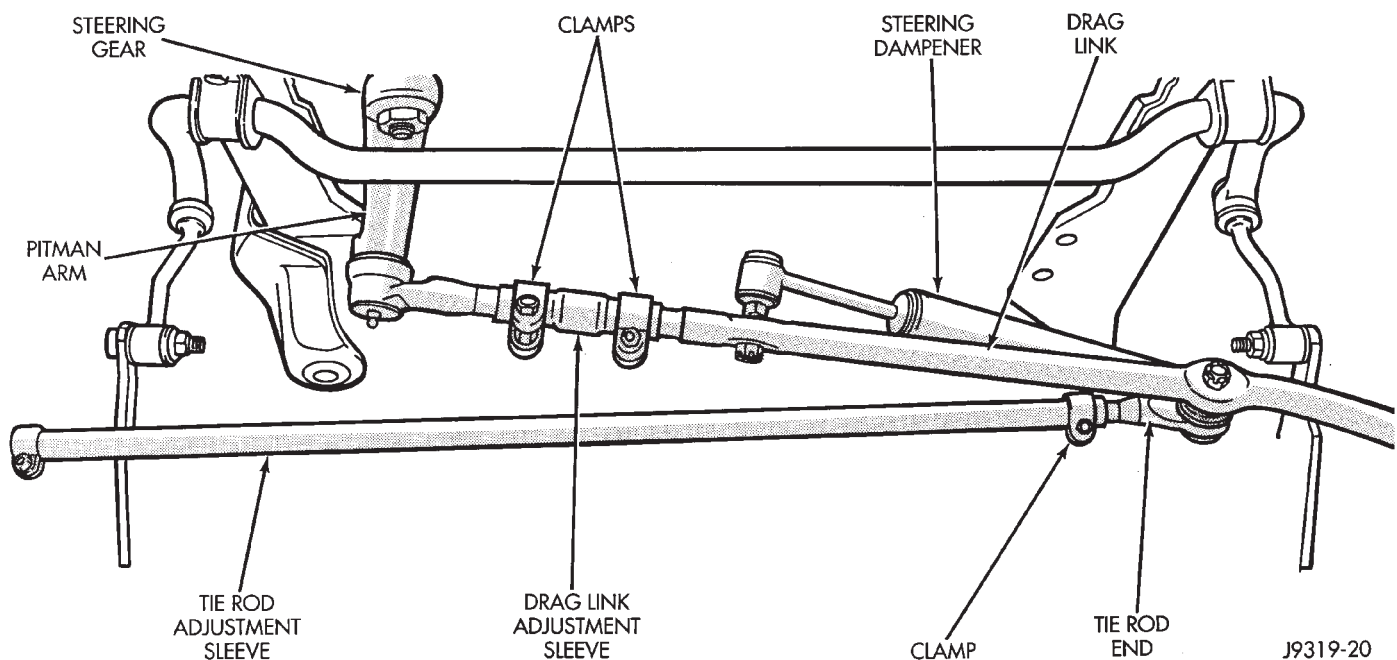

Fig. 1 RHD Steering Linkage

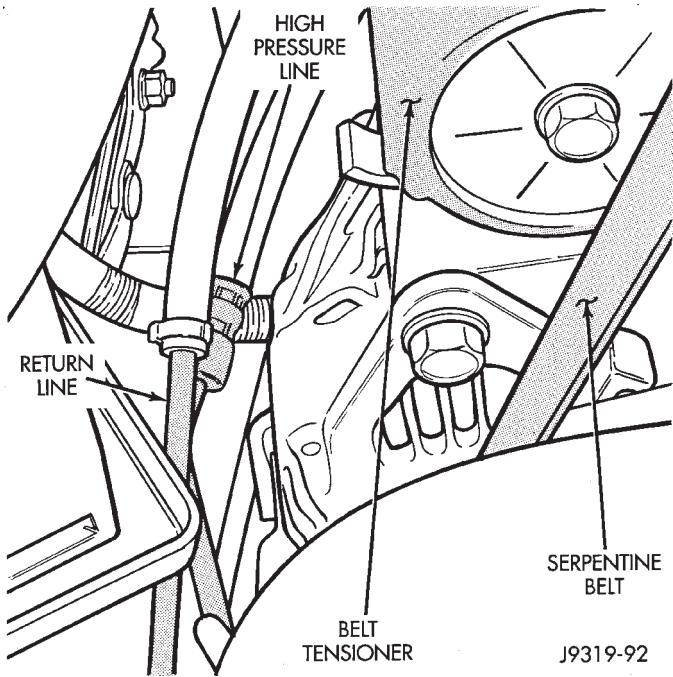

Fig. 3 Pressure And Return Lines

(4) Remove pressure and return line bracket at belt tensioner (Fig. 5).

INSTALLATION

(1) Wipe hose ends, pump and gear unions clean.

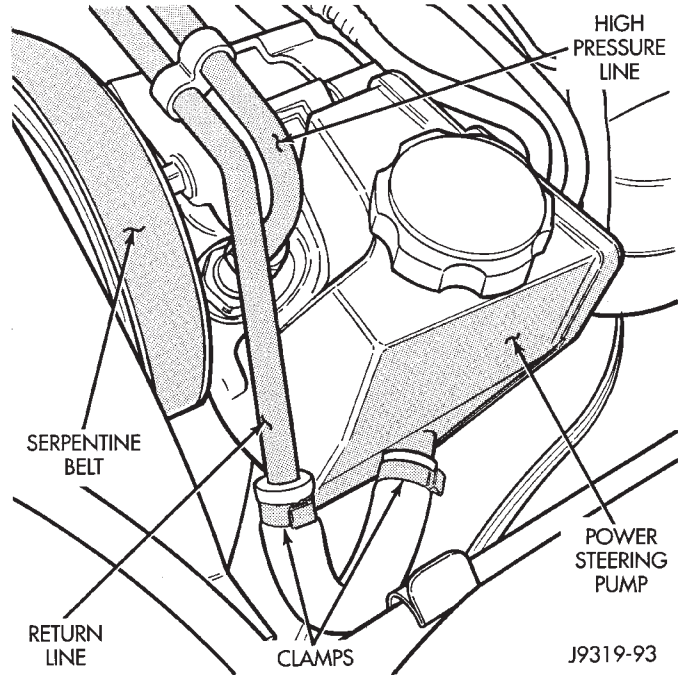

Fig. 4 Fluid Lines At Pump

(2) Install pressure and return line on the pump and gear (Fig. 2, 3, 4).

(3) Align the pressure and return line bracket to the tensioner bracket. Install the screw. Tighten the screw to 28 N·m (21 ft. lbs.) torque.

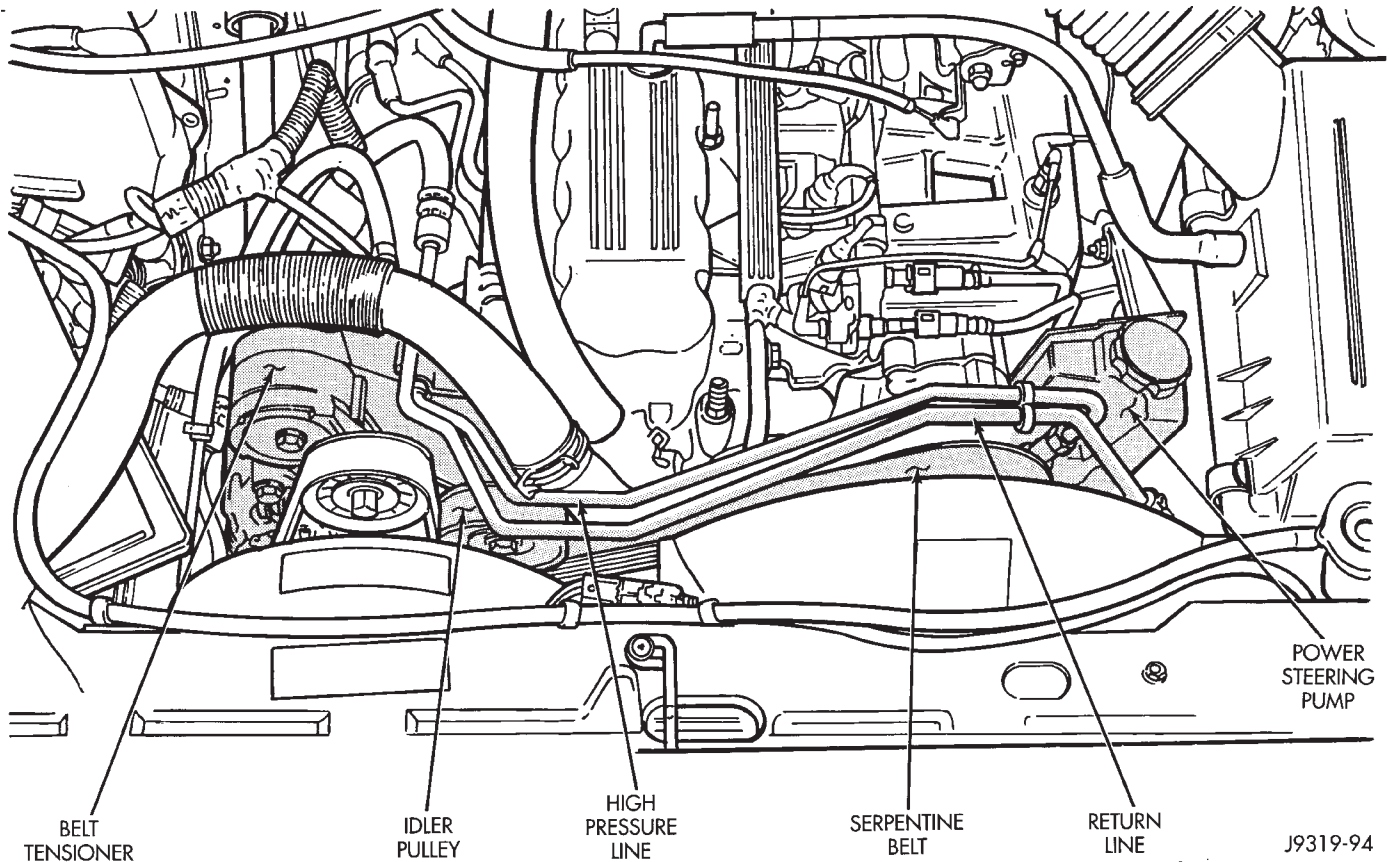

Fig. 5 Pressure And Return Line Routing

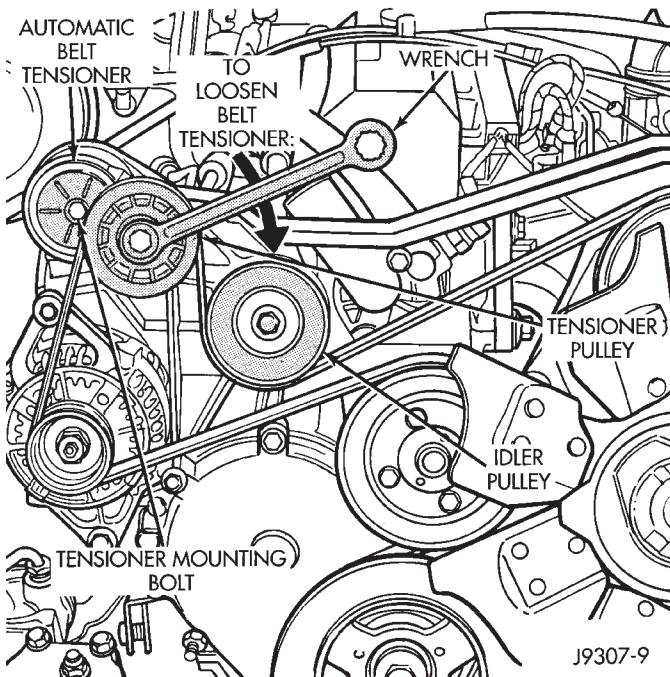

Fig. 6 Belt Tensioner

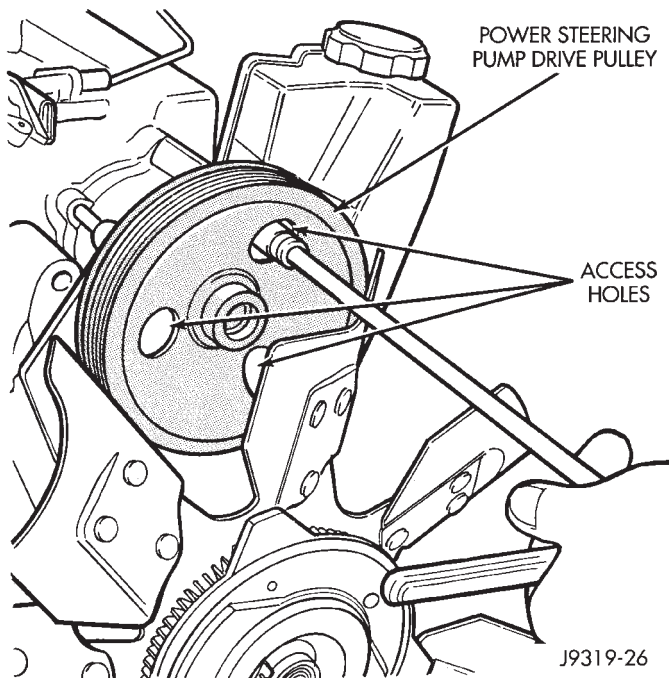

Fig. 7 Pump Mounting Screw Removal/Installation

(4) Tighten fittings at pump and gear to 28 N·m (21 ft. lbs.) torque.

(5) After installation, add power steering fluid, inspect and test for fluid leaks.

PUMP REPLACEMENT

REMOVAL

(1) Remove and cap pressure and return lines from pump. Refer to Pressure and Return Line Replacement in this section.

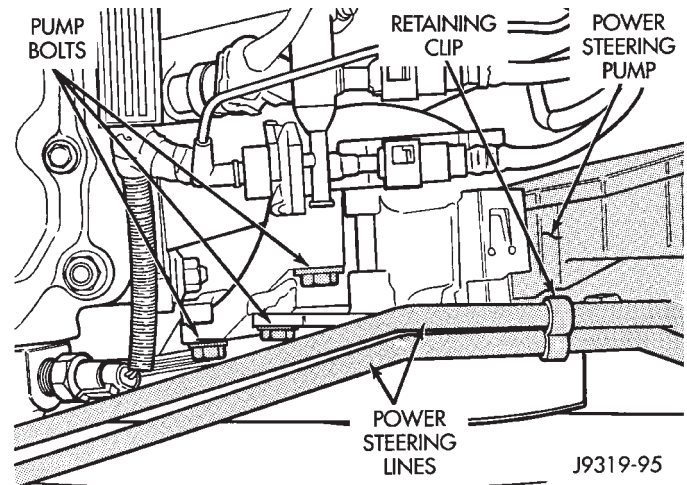

Fig. 8 Power Steering Pump Mounting

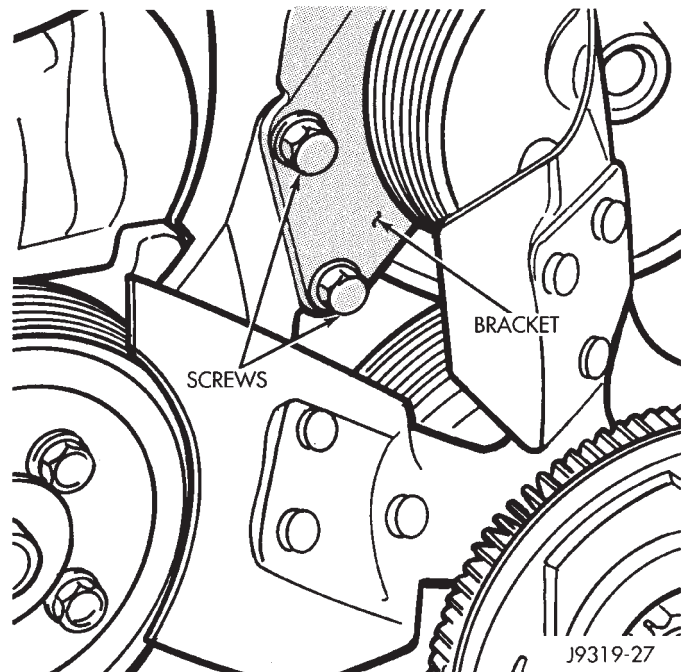

Fig. 9 Front Bracket

(2) Remove belt tension, turn tensioner clock-wise and slip belt off pulley (Fig. 6).

(3) Remove the screws retaining front bracket and pump to the rear bracket (Fig. 7, 8).

(4) Remove screws that attach the front bracket to the rear bracket (Fig. 9).

(5) Remove pump from bracket.

To remove the rear bracket from engine, the air conditioning compressor and bracket must be removed first. Refer to Group 24, Heating and Air Conditioning for removal procedures.

(6) Remove fan from pulley and hub on rear bracket.

(7) Remove 4 screws attaching the rear bracket to block (Fig. 10, 11).

(8) Remove bracket from engine.

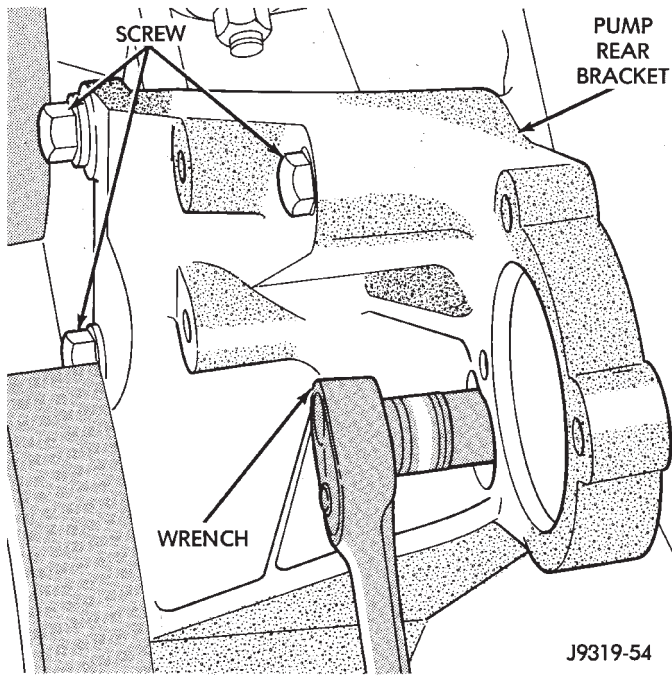

Fig. 10 Rear Bracket (Front View)

INSTALLATION

(1) Install the rear bracket to engine. Install screws finger tight.

(2) Tighten front screws to 48 N·m (35 ft. lbs.) torque. Tighten side screw to 48 N·m (35 ft. lbs.) torque. It is important to torque the front screws **FIRST** and the side screw **LAST**. This will prevent the bracket from twisting or distorting.

(3) Install fan to pulley and hub. Tighten the nuts to 27 N·m (20 ft. lbs.) torque.

(4) Install air conditioning bracket and compressor to engine. Refer to Group 24, Heating and Air Conditioning for installation procedures.

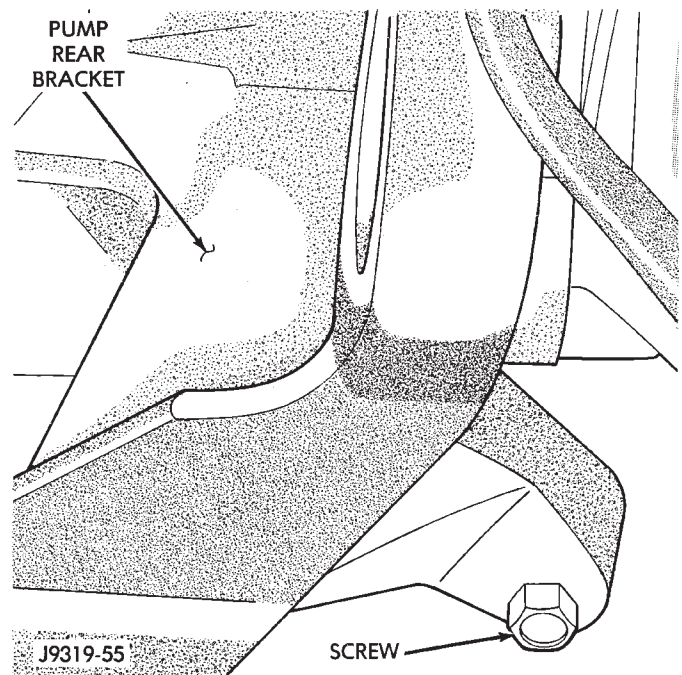

Fig. 11 Rear Bracket (Side View)

(5) Loosely assemble screws through front bracket, pump and into rear bracket.

(6) Install screws that attach the front bracket to the rear bracket (Fig. 8). Tighten the screws to 27 N·m (20 ft. lbs.) torque (Fig. 7).

(7) Install belt, turn tensioner clockwise and slip belt onto pulley (Fig. 6).

(8) Install pressure and return lines to pump. Refer to Pressure and Return Line Replacement in this section.

(9) After installation, add power steering fluid, inspect and test for fluid leaks. Refer to Power Steering Pump—Initial Operation.

TORQUE SPECIFICATIONS

POWER STEERING GEAR

DESCRIPTION	TORQUE
Adjustment Plug Initial Adjustment . . .	109 N·m (80 ft. lbs.)
Adjustment Plug Locknut	109 N·m (80 ft. lbs.)
Adjustment Screw Locknut	49 N·m (36 ft. lbs.)
Coupler Shaft Pinch Bolts	47 N·m (35 ft. lbs.)
Gear to Frame Bolts (XJ)	95 N·m (70 ft. lbs.)
Gear to Frame Bolts (YJ)	106 N·m (78 ft. lbs.)
Pitman Arm (Shaft) Nut	251 N·m (185 ft. lbs.)
Return Guide Clamp Screw	58 N·m (43 in. lbs.)
Rack-Piston Plug	102 N·m (75 ft. lbs.)
Side Cover Bolts	60 N·m (44 ft. lbs.)

J9319-82

MANUAL STEERING GEAR

DESCRIPTION	TORQUE
Adjustment Locknut	68 N·m (50 ft. lbs.)
Adjustment Screw Locknut	34 N·m (25 ft. lbs.)
Return Guide Clamp Screw	14 N·m (10 in. lbs.)
Side Cover Bolts	61 N·m (45 ft. lbs.)
Adjustment Screw Locknut	34 N·m (25 ft. lbs.)
Gear to Frame Bolts (XJ)	95 N·m (70 ft. lbs.)
Gear to Frame Bolts (YJ)	106 N·m (78 ft. lbs.)

J9319-83

STEERING LINKAGE—XJ

DESCRIPTION	TORQUE
Drag Link to Steering Knuckle Nut	47 N·m (35 ft. lbs.)
Drag Link to Pitman Arm Nut	74 N·m (55 ft. lbs.)
Drag Link Adjustment Clamp Nut . . .	49 N·m (36 ft. lbs.)
Pitman Arm (Shaft) Nut	251 N·m (185 ft. lbs.)
Steering Dampener to Axle Bracket Nut	74 N·m (55 ft. lbs.)
Steering Dampener to Drag Link Nut	74 N·m (55 ft. lbs.)
Tie Rod to Steering Knuckle Nut . . .	47 N·m (35 ft. lbs.)
Tie Rod Clamp Nut	27 N·m (20 ft. lbs.)

J9319-84

STEERING LINKAGE—YJ

DESCRIPTION	TORQUE
Drag Link to Tie Rod Nut	47 N·m (35 ft. lbs.)
Drag Link to Pitman Arm Nut	74 N·m (55 ft. lbs.)
Drag Link Adjustment Clamp Nut . . .	27 N·m (20 ft. lbs.)
Pitman Arm (Shaft) Nut	251 N·m (185 ft. lbs.)
Steering Dampener to Axle Bracket Nut	74 N·m (55 ft. lbs.)
Steering Dampener to Tie Rod Nut	74 N·m (55 ft. lbs.)
Tie Rod to Steering Knuckle Nut . . .	47 N·m (35 ft. lbs.)
Tie Rod Adjustment Clamp Nut	49 N·m (36 ft. lbs.)

J9319-85

POWER STEERING PUMP

DESCRIPTION	TORQUE
Bracket to Block Bolts	47 N·m (35 ft. lbs.)
Pump to Adjustment Bracket	28 N·m (21 ft. lbs.)
Flow Control Valve to Pump Body . .	75 N·m (55 ft. lbs.)
High Pressure Fluid Fitting at Pump and Gear	28 N·m (21 ft. lbs.)
Return Fluid Fitting at Gear	28 N·m (21 ft. lbs.)

J9319-86

STEERING COLUMN—XJ

DESCRIPTION	TORQUE
Steering Wheel to Column Shaft Nut	35 N·m (26 ft. lbs.)
Toe Plate Bolts/Nuts	8 N·m (66 in. lbs.)
Upper Bracket Support Nuts	30 N·m (22 ft. lbs.)
Support Plate to Column	20 N·m (180 in. lbs.)
Coupler Shaft to Column	30 N·m (22 ft. lbs.)

J9519-55

STEERING COLUMN—YJ

DESCRIPTION	TORQUE
Steering Wheel to Column Shaft Nut	34 N·m (25 ft. lbs.)
Toe Plate Bolts/Nuts	21 N·m (192 in. lbs.)
Upper Bracket Support Bolts	30 N·m (270 in. lbs.)
Support Plate to Column	30 N·m (270 in. lbs.)
Coupler Shaft to Column	30 N·m (22 ft. lbs.)

J9519-56