

# INSTRUMENT PANEL AND GAUGES

## GROUP INDEX

INSTRUMENT PANEL AND GAUGES—XJ ..... 1      INSTRUMENT PANEL AND GAUGES—YJ ..... 24

# INSTRUMENT PANEL AND GAUGES—XJ

## CONTENTS

	page		page
DIAGNOSIS .....	5	SERVICE PROCEDURES .....	17
GENERAL INFORMATION .....	1	SPECIFICATIONS .....	23

## GENERAL INFORMATION

Following are general descriptions of major instrument panel components. Refer to Group 8W - Wiring Diagrams for complete circuit descriptions and diagrams.

### INSTRUMENT PANEL

Modular instrument panel construction allows all gauges and controls to be serviced from the front of the panel. In addition, most instrument panel wiring or heater and air conditioning components can be accessed without complete instrument panel removal. If necessary, the instrument panel can be rolled-down and removed from the vehicle as an assembly.

Removal of the instrument cluster bezel allows access to the cluster assembly, most switches, the climate controls, and the radio. Removal of the cluster assembly allows access to the individual gauges, illumination and indicator lamp bulbs, printed circuits, and most wiring.

Removal of the lower instrument panel allows access to heater and air conditioning components, the fuseblock module, the relay center, and other wiring and electrical components. Those models equipped with a driver's-side airbag restraint have a knee blocker and reinforcement behind the driver's-side lower instrument panel.

The instrument panel layout is mirror image for left-hand and right-hand drive vehicles. In most cases, the diagnosis and service procedures found in this group are applicable to either vehicle. Although,

most illustrations represent only the typical left-hand drive version. Exceptions are clearly identified as Right-Hand Drive (RHD).

### INSTRUMENT CLUSTERS

Two basic instrument cluster options are offered on XJ (Cherokee) models. One is referred to as a low-line cluster, and the other is referred to as a high-line cluster. Each cluster is divided into two areas: the gauge area, and the tell-tale area. Each area is served by a separate printed circuit and wiring connector. Some variations of each cluster exist due to optional equipment and regulatory requirements.

The low-line cluster includes the following gauges:

- fuel gauge
  - speedometer/odometer.
- The low-line cluster includes provisions for the following indicator lamps:
- anti-lock brake system lamp
  - brake warning lamp
  - coolant temperature warning lamp
  - four-wheel drive indicator lamps
  - generator warning lamp
  - headlamp high beam indicator lamp
  - low oil pressure warning lamp
  - low washer fluid warning lamp
  - malfunction indicator (Check Engine) lamp
  - seat belt reminder lamp
  - turn signal indicator lamps
  - upshift indicator lamp.

The high-line cluster includes the following gauges:

- coolant temperature gauge
- fuel gauge
- oil pressure gauge
- speedometer/odometer
- tachometer
- trip odometer
- voltmeter.

The high-line cluster includes provisions for the following indicator lamps:

- anti-lock brake system lamp
- brake warning lamp
- four-wheel drive indicator lamps
- headlamp high beam indicator lamp
- low fuel warning lamp
- low washer fluid warning lamp
- malfunction indicator (Check Engine) lamp
- seat belt reminder lamp
- turn signal indicator lamps
- upshift indicator lamp.

## GAUGES

With the ignition switch in the ON or START position, voltage is supplied to all gauges through the instrument cluster gauge area printed circuit. With the ignition switch in the OFF position, voltage is not supplied to the gauges. A gauge pointer may remain within the gauge scale after the ignition switch is OFF. However, the gauges do not accurately indicate any vehicle condition unless the ignition switch is ON.

All gauges except the odometer are air core magnetic units. Two fixed electromagnetic coils are located within the gauge. These coils are wrapped at right angles to each other around a movable permanent magnet. The movable magnet is suspended within the coils on one end of a shaft. The gauge needle is attached to the other end of the shaft.

One of the coils has a fixed current flowing through it to maintain a constant magnetic field strength. Current flow through the second coil changes, which causes changes in its magnetic field strength. The current flowing through the second coil can be changed by:

- a variable resistor-type sending unit (fuel level, coolant temperature, or oil pressure)
- changes in electrical system voltage (voltmeter)
- electronic control circuitry (speedometer/odometer, tachometer).

The gauge needle moves as the movable permanent magnet aligns itself to the changing magnetic fields created around it by the electromagnets.

### COOLANT TEMPERATURE GAUGE

The coolant temperature gauge gives an indication of engine coolant temperature. The coolant temperature sending unit is a thermistor that changes electrical resistance with changes in engine coolant

temperature. High sending unit resistance causes low coolant temperature readings. Low resistance causes high coolant temperature readings.

The gauge will read at the high end of the scale when the ignition switch is turned to the START position. This is caused by the bulb test circuit wiring provision. The same wiring is used for the high-line cluster with a coolant temperature gauge and the low-line cluster with a coolant temperature warning lamp. Sending unit resistance values are shown in a chart in Specifications.

### FUEL GAUGE

The fuel gauge gives an indication of the level of fuel in the fuel tank. The fuel gauge sending unit has a float attached to a swing-arm in the fuel tank. The float moves up or down within the fuel tank as fuel level changes. As the float moves, an electrical contact on the swing-arm wipes across a resistor coil, which changes sending unit resistance. High sending unit resistance causes low fuel level readings. Low resistance causes high fuel level readings. Sending unit resistance values are shown in a chart in Specifications.

### OIL PRESSURE GAUGE

The oil pressure gauge gives an indication of engine oil pressure. The combination oil pressure sending unit contains a flexible diaphragm. The diaphragm moves in response to changes in engine oil pressure. As the diaphragm moves, sending unit resistance increases or decreases. High resistance on the gauge side of the sending unit causes high oil pressure readings. Low resistance causes low oil pressure readings. Sending unit resistance values are shown in a chart in Specifications.

### SPEEDOMETER/ODOMETER

The speedometer/odometer gives an indication of vehicle speed and travel distance. The speedometer receives a vehicle speed pulse signal from the Vehicle Speed Sensor (VSS). An electronic integrated circuit contained within the speedometer reads and analyzes the pulse signal. It then adjusts the ground path resistance of one electromagnet in the gauge to control needle movement. It also sends signals to an electric stepper motor to control movement of the odometer number rolls. Frequency values for the pulse signal are shown in a chart in Specifications.

The VSS is mounted to an adapter near the transmission (two-wheel drive) or transfer case (four-wheel drive) output shaft. The sensor is driven through the adapter by a speedometer pinion gear. The adapter and pinion vary with transmission, transfer case, axle ratio and tire size. Refer to Group 21 - Transmission and Transfer Case for more information.

### TACHOMETER

The tachometer gives an indication of engine speed in Revolutions-Per-Minute (RPM). With the engine running, the tachometer receives an engine speed pulse signal from the Powertrain Control Module (PCM). An electronic integrated circuit contained within the tachometer reads and analyzes the pulse signal. It then adjusts the ground path resistance of one electromagnet in the gauge to control needle movement. Frequency values for the pulse signal are shown in a chart in Specifications.

### TRIP ODOMETER

The trip odometer is driven by the same electronic integrated circuit as the speedometer/odometer. However, by depressing the trip odometer reset knob on the face of the speedometer, the trip odometer can be reset to zero. The trip odometer is serviced only as a part of the speedometer/odometer gauge assembly.

### VOLTMETER

The voltmeter is connected in parallel with the battery. With the ignition switch ON, the voltmeter indicates battery or generator output voltage, whichever is greater.

### INDICATOR LAMPS

Indicator lamps are located in two areas within the cluster. Each of these areas is served by a separate printed circuit and cluster connector. Those lamps in the gauge area of the cluster share the gauge area printed circuit and cluster connector A. Those lamps in the tell-tale area of the cluster use the tell-tale printed circuit and cluster (tell-tale) connector B.

Up to ten indicator lamps can be found in the tell-tale area of the cluster. These lamps are arranged in five stacked rows with two lamps in each row, located to the driver's side of the main cluster.

#### ANTI-LOCK BRAKE SYSTEM LAMP

The Anti-Lock Brake System (ABS) lamp is switched to ground by the ABS module. The module lights the lamp when the ignition switch is turned to the START position as a bulb test. The lamp will stay on for 3 to 5 seconds after vehicle start-up to indicate a system self-test is in process. If the lamp remains on after start-up, or comes on and stays on while driving, it may indicate that the ABS module has detected a system malfunction or that the system has become inoperative. Refer to Group 5 - Brakes for more information.

#### BRAKE WARNING LAMP

The brake warning lamp warns the driver that the parking brake is applied or that the pressures in the two halves of the split brake hydraulic system are unequal. With the ignition switch turned ON, battery

voltage is supplied to one side of the indicator bulb. A ground path for the bulb is provided by 3 switches. The bulb will light when:

- the brake warning switch is closed (indicating unequal brake system hydraulic pressures possibly due to brake fluid leakage)
- the ignition switch is in the START position (bulb test)
- the parking brake switch is closed (parking brake is applied).

Refer to Group 5 - Brakes for more information.

#### COOLANT TEMPERATURE WARNING LAMP

The coolant temperature warning lamp lights whenever engine coolant temperature is too high. Battery voltage is supplied to one side of the indicator bulb when the ignition switch is turned ON. The normally open coolant temperature switch is connected to the other side of the bulb. When coolant temperature is too high, the switch closes. This provides a ground path for the indicator bulb, which causes it to light. The lamp is also grounded and should light with the ignition switch in the START position as a bulb test.

#### FOUR-WHEEL DRIVE INDICATOR LAMPS

##### PART TIME

On vehicles with Command-Trac 4WD, the Part Time lamp lights when the transfer case is engaged in the 4H or 4L position. On vehicles with Selec-Trac 4WD, the Part Time lamp lights when the transfer case is engaged in the 4 X 4 PART TIME or 4 LO position. Voltage is supplied to one side of the indicator bulb. A switch in the transfer case is connected to the other side of the indicator bulb. When the switch is closed, a path to ground is provided and the indicator bulb lights.

##### FULL TIME

The Full Time lamp is only operational on vehicles equipped with Selec-Trac 4WD. The Full Time lamp lights when the transfer case is engaged in the 4 X 4 Full Time position. Voltage is supplied to one side of the indicator bulb. A switch in the transfer case is connected to the other side of the indicator bulb. When the switch is closed, a path to ground is provided and the indicator bulb lights.

#### GENERATOR WARNING LAMP

The generator warning lamp lights with the ignition switch turned to ON, but should go out whenever the engine is running. If the lamp comes on and stays on while the engine is running, it indicates that a charging system malfunction exists. One side of the bulb is connected to ignition-switched battery feed. The other side of the bulb is switched to ground by the Powertrain Control Module (PCM).

#### HEADLAMP HIGH BEAM INDICATOR LAMP

The high beam indicator lamp is controlled by the headlamp dimmer (multi-function) switch. One side of the indicator bulb is grounded at all times. The other side of the bulb receives battery feed through the contacts of the dimmer switch when the multi-function switch stalk is actuated to turn the headlamp high beams on. Refer to Group 8L - Lamps for more information.

#### LOW FUEL WARNING LAMP

A Light-Emitting Diode (LED) on the face of the fuel gauge will light when the fuel level falls below approximately 4 gallons. A low fuel warning module attached to the rear of the fuel gauge controls when the LED will light. When the module senses 66.5 ohms or more resistance from the fuel level sending unit for 10 continuous seconds, the LED will light. When the module senses 63.5 ohms or less resistance from the fuel level sending unit for 20 continuous seconds, the LED is turned off.

#### LOW OIL PRESSURE WARNING LAMP

The low oil pressure warning lamp lights with the ignition switch in the ON position and the engine not running. The lamp should be off when the engine is running. Battery voltage is supplied to one side of the indicator bulb when the ignition switch is turned ON. The warning lamp side of the combination oil pressure sending unit is connected to the other side of the bulb. When normal engine oil pressure is applied to the sending unit, resistance on the warning lamp side is high and the lamp goes off. When engine oil pressure is too low, resistance on the warning lamp side of the sending unit is low, which causes the bulb to light.

#### LOW WASHER FLUID WARNING LAMP

The low washer fluid warning lamp indicates when the fluid level in the washer reservoir is too low. The washer fluid level sensor uses a float in the reservoir to monitor fluid level. The action of the float opens or closes the switch within the sensor that provides ignition-switched battery voltage to the lamp bulb. Refer to Group 8K - Wiper and Washer Systems for more information.

#### MALFUNCTION INDICATOR LAMP

The CHECK ENGINE or Malfunction Indicator Lamp (MIL) lights each time the ignition switch is turned ON, and stays on for 3 seconds as a bulb test. If the Powertrain Control Module (PCM) receives an incorrect signal or no signal from certain fuel or

emission system related circuits or components, the lamp is turned on. This will indicate that the PCM has recorded a Diagnostic Trouble Code (DTC) in electronic memory for a circuit or component malfunction. Refer to Group 14 - Fuel System for more information.

#### SEAT BELT REMINDER LAMP

The seat belt reminder lamp lights for 4 to 8 seconds after the ignition switch is turned to the ON position. A timer in the chime/buzzer module controls ignition-switched battery feed to the lamp. Refer to Group 8U - Chime/Buzzer Warning Systems for more information.

#### TURN SIGNAL INDICATOR LAMPS

The left and right turn signal indicator lamps are controlled by the turn signal and hazard warning (multi-function) switches. One side of the bulb for each lamp is grounded at all times. The other side of the bulb receives battery feed through the contacts of the multi-function switch when the turn signal lever (multi-function switch stalk) or hazard warning button are actuated. Refer to Group 8J - Turn Signal and Hazard Warning Systems for more information.

#### UPSHIFT INDICATOR LAMP

Vehicles equipped with manual transmissions have an optional upshift indicator lamp. Ground feed for the lamp is switched by the Powertrain Control Module (PCM). The lamp lights to indicate when the driver should shift to the next highest gear for best fuel economy. The PCM will turn the lamp off after 3 to 5 seconds if the upshift is not performed. The lamp will remain off until the vehicle stops accelerating and is brought back to the range of lamp operation, or until the transmission is shifted into another gear.

The indicator lamp is normally on when the ignition switch is turned ON and is turned off when the engine is started. The lamp will be turned on during vehicle operation according to engine speed and load.

#### CLUSTER ILLUMINATION LAMPS

All cluster illumination lamps receive battery feed from the instrument lamps fuse in the fuseblock module through the panel dimmer rheostat of the headlamp switch. When the park or headlamps are on, the cluster illumination lamps light. Illumination brightness can be adjusted by rotating the headlamp switch knob (clockwise to dim, counterclockwise to brighten).

## DIAGNOSIS

## GAUGES

If an individual gauge is inoperative, see the diagnostic procedure under the heading for that gauge. If more than one gauge is inoperative, perform the following:

(1) Check fuse 17 (fuse 26 - RHD) in the fuseblock module. If OK, go to next step. If not OK, replace fuse.

(2) Check for battery voltage at fuse 17 (fuse 26 - RHD) with ignition switch in ON position. If OK, go to next step. If not OK, repair open in circuit from ignition switch and/or refer to Group 8D - Ignition Systems for testing of ignition switch.

(3) Turn ignition switch to OFF. Disconnect battery negative cable. Remove instrument cluster bezel and cluster assembly. Disconnect gauge cluster connector A.

(4) Connect battery negative cable. Turn ignition switch to ON. Check for battery voltage at cavity A8 (cavity A7 - RHD) of cluster connector A. If OK, go to next step. If not OK, repair open in circuit from fuse 17 (fuse 26 - RHD) as required.

(5) Turn ignition switch to OFF. Disconnect battery negative cable. Probe cavities A3 and B2 of cluster connector A. Check for continuity to a good ground. There should be continuity. If OK, replace gauge cluster printed circuit. If not OK, repair open in circuit as required.

## COOLANT TEMPERATURE GAUGE

The diagnosis found here addresses an inoperative gauge condition. If the problem being diagnosed is related to gauge accuracy, be certain to confirm that problem is with gauge and not with cooling system performance. Actual engine coolant temperature should be checked with a test gauge or thermometer and compared to gauge readings before you proceed with gauge diagnosis. Refer to Group 7 - Cooling System for more information.

(1) Turn ignition switch to ON. Disconnect coolant temperature sending unit connector. Sending unit (Fig. 1) is located near the left rear corner of the cylinder head. The gauge needle should move to low end of gauge scale. If OK, go to next step. If not OK, go to step 3.

(2) Install a jumper wire from sending unit wiring to ground. The gauge needle should move to high end of gauge scale. If OK, replace sending unit. If not OK, remove jumper wire and go to next step.

(3) Turn ignition switch to OFF. Disconnect battery negative cable. Remove instrument cluster bezel and cluster assembly. Disconnect gauge cluster connector A.

(4) Probe cavity A1 of cluster connector A. Check for continuity to a good ground. There should be no

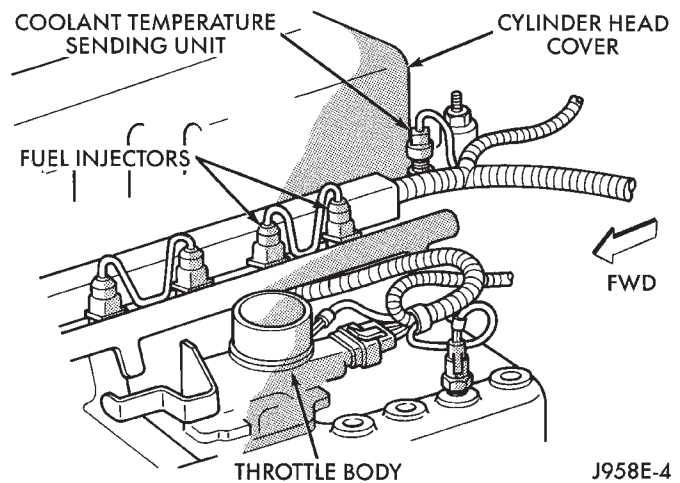


Fig. 1 Coolant Temperature Switch/Sending Unit - Typical

continuity. If OK, go to next step. If not OK, repair short in circuit as required.

(5) Still probing cavity A1 of cluster connector A, check for continuity to sending unit wiring connector. There should be continuity. If OK, replace gauge. If not OK, repair open in circuit as required.

## FUEL GAUGE

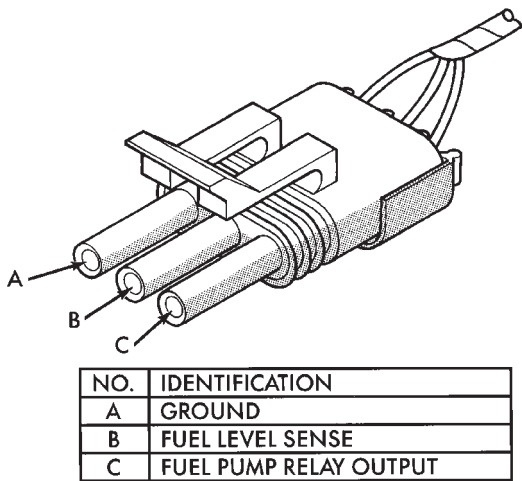
The diagnosis found here addresses an inoperative gauge condition. If the problem being diagnosed is related to gauge accuracy, be certain to confirm that problem is with gauge and not with fuel tank. Inspect fuel tank for signs of damage or distortion that could affect sending unit performance before you proceed with gauge diagnosis. Refer to Group 14 - Fuel System for more information.

(1) Turn ignition switch to ON. Disconnect fuel gauge sending unit connector. Connector is located near the left front corner of the fuel tank. The gauge needle should move to low end of gauge scale. If OK, go to next step. If not OK, go to step 4.

(2) Connect a jumper wire between terminals A and B in the body half of the fuel gauge sending unit connector (Fig. 2). The gauge needle should move to high end of gauge scale. If OK, refer to Group 14 - Fuel System for procedure to replace sending unit. If not OK, remove jumper wire and go to next step.

(3) Turn ignition switch to OFF. Disconnect battery negative cable. Check for continuity between terminal A in the body half of fuel gauge sending unit connector and a good ground. There should be continuity. If OK, go to next step. If not OK, repair circuit to ground as required.

(4) Remove instrument cluster bezel and cluster assembly. Disconnect instrument cluster connector A.



J958E-5

**Fig. 2 Fuel Gauge Sending Unit Connector**

(5) Probe cavity B1 of cluster connector A. Check for continuity to a good ground. There should be no continuity. If OK, go to next step. If not OK, repair short circuit as required.

(6) Still probing cavity B1 of cluster connector A, check for continuity to cavity B of sending unit body half connector. There should be continuity. If OK, replace gauge. If not OK, repair open circuit as required.

#### OIL PRESSURE GAUGE

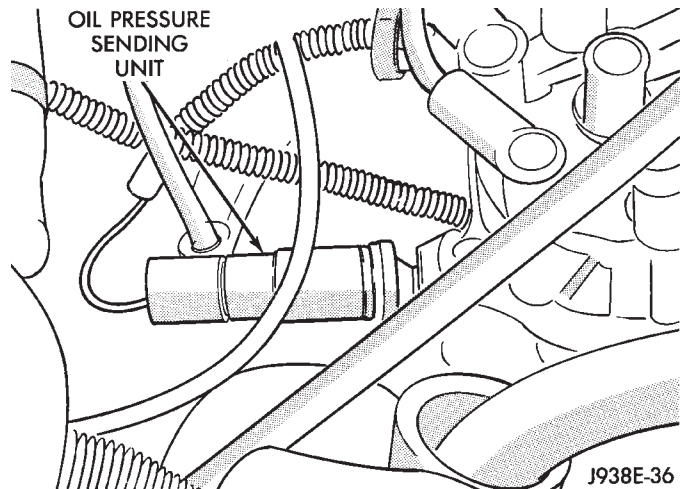
The diagnosis found here addresses an inoperative gauge condition. If the problem being diagnosed is related to gauge accuracy, be certain to confirm that problem is with gauge and not with engine oiling system performance. Actual engine oil pressure should be checked with a test gauge and compared to gauge readings before you proceed with gauge diagnosis. Refer to Group 9 - Engines for more information.

(1) Turn ignition switch to ON. Disconnect oil pressure sending unit connector. The sending unit (Fig. 3) is located on right side of engine block. On 2.5L engine, it is just forward of ignition distributor and just to the rear of generator mounting bracket. On 4.0L engine, it is just to the rear of ignition distributor and above oil filter adapter. The gauge needle should move to high end of gauge scale. If OK, go to next step. If not OK, go to step 3.

(2) Install a jumper wire from sending unit wiring to ground. The gauge needle should move to low end of gauge scale. If OK, replace sending unit. If not OK, remove jumper wire and go to next step.

(3) Turn ignition switch to OFF. Disconnect battery negative cable. Remove instrument cluster bezel and cluster assembly. Disconnect instrument cluster connector A.

(4) Probe cavity B7 (cavity B8 - RHD) of cluster connector A. Check for continuity to a good ground. There should be no continuity. If OK, go to next step. If not OK, repair short circuit as required.



J938E-36

**Fig. 3 Oil Pressure Switch/Sending Unit - Typical**

(5) Still probing cavity B7 (cavity B8 - RHD) of cluster connector A, check for continuity to sending unit wire connector. There should be continuity. If OK, replace gauge. If not OK, repair open circuit as required.

#### SPEEDOMETER/ODOMETER

The diagnosis found here addresses an inoperative gauge condition. If the problem being diagnosed is related to gauge accuracy, be certain to confirm that problem is with gauge and not with incorrect speedometer pinion, axle ratio or tire size. Refer to Group 21 - Transmission and Transfer Case for more information.

(1) Perform vehicle speed sensor test as described in the appropriate Powertrain Diagnostic Procedures manual. If OK, go to next step. If not OK, replace vehicle speed sensor.

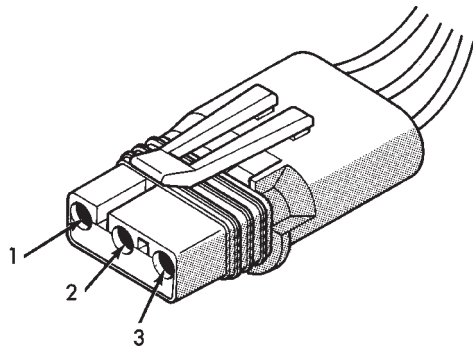
(2) Disconnect battery negative cable. Unplug vehicle speed sensor, PCM, and daytime running lamp module connectors. Remove instrument cluster bezel and cluster assembly. Disconnect instrument cluster connector A.

(3) Probe cavity A5 (cavity B6 - RHD) of cluster connector A. Check for continuity to a good ground. There should be no continuity. If OK, go to next step. If not OK, repair short circuit as required.

(4) Still probing cavity A5 (cavity B6 - RHD) of cluster connector A, check for continuity to cavity 1 of vehicle speed sensor connector (Fig. 4). There should be continuity. If OK, replace speedometer/odometer. If not OK, repair open circuit as required.

#### TACHOMETER

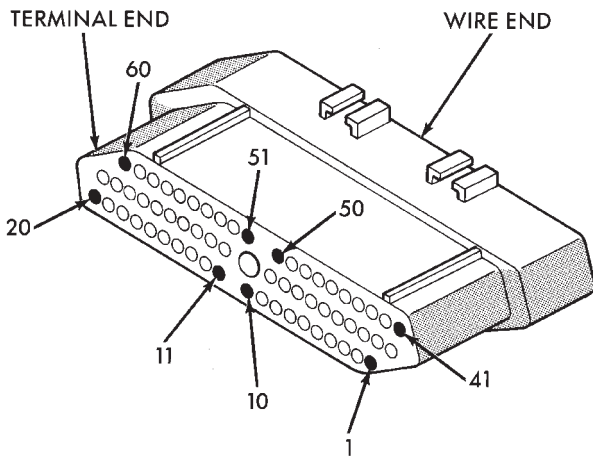
(1) With engine running, check for tachometer signal at pin 43 of PCM connector (Fig. 5). See Tachometer Calibration chart in Specifications. If OK, go to next step. If not OK, replace PCM.



NO.	IDENTIFICATION
1	VSS SIGNAL
2	SENSOR GROUND
3	SENSOR SUPPLY

J958E-6

**Fig. 4 Vehicle Speed Sensor Connector**



NO.	IDENTIFICATION
32	MALFUNCTION INDICATOR LAMP
36	GENERATOR WARNING LAMP
43	TACHOMETER SIGNAL
54	UPSHIFT INDICATOR LAMP

J958E-7

**Fig. 5 Powertrain Control Module Connector**

(2) Disconnect battery negative cable. Unplug PCM connector. Remove instrument cluster bezel and cluster assembly. Disconnect instrument cluster connector A.

(3) Probe cavity A6 of cluster connector A. Check for continuity to a good ground. There should be no continuity. If OK, go to next step. If not OK, repair short circuit as required.

(4) Still probing cavity A6 of cluster connector A, check for continuity to cavity 43 of PCM connector. There should be continuity. If OK, replace tachometer. If not OK, repair open circuit as required.

**TRIP ODOMETER**

If the trip odometer is inoperative, but the speedometer/odometer functions are unaffected, replace speedometer assembly. If speedometer/odometer functions are affected, see Speedometer/Odometer diagnosis in this section.

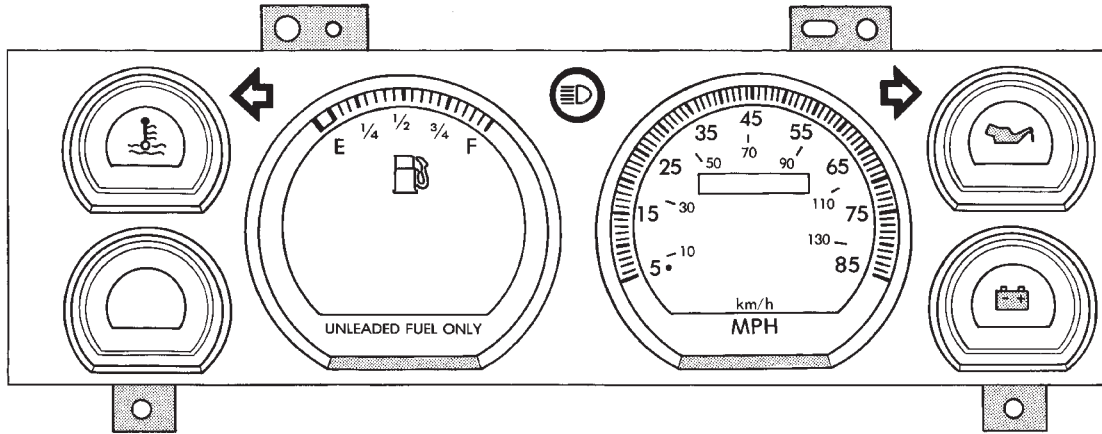
**VOLTMETER**

(1) Turn ignition switch to ON. Voltmeter should read battery voltage. If all gauges except voltmeter are OK, go to next step. If other gauges are inoperative, see Gauges in this section for diagnosis.

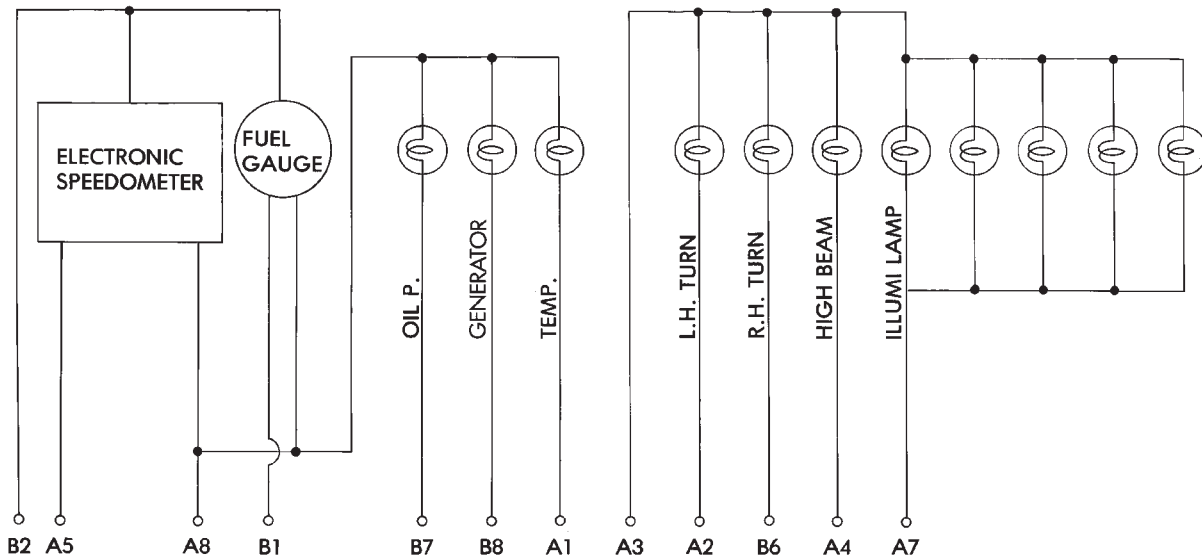
(2) Using an accurate test voltmeter, measure battery voltage at battery. Compare this reading to instrument cluster voltmeter reading. Now see Voltmeter Calibration chart in Specifications. If voltmeter does not perform to specification, replace voltmeter.

LOW-LINE GAUGE CLUSTER

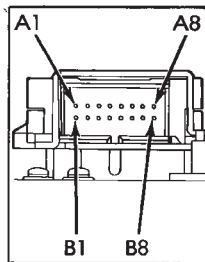
LOW-LINE



GAUGE CLUSTER CIRCUIT SCHEMATIC



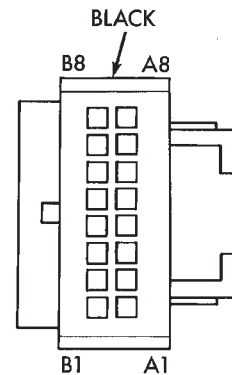
GAUGE CLUSTER PRINTED CIRCUIT TERMINALS



GAUGE CLUSTER LEGEND

NO.	IDENTIFICATION
A1	ENGINE COOLANT TEMP
A2	LEFT TURN INDICATOR
A3	GROUND
A4	HEADLAMP HIGH BEAM
A5	VEHICLE SPEED SENSOR
A6	TACHOMETER
A7	ILLUMINATION
A8	IGNITION
B1	FUEL GAUGE
B2	GROUND
B3	NOT USED
B4	NOT USED
B5	NOT USED
B6	RIGHT TURN INDICATOR
B7	ENGINE OIL PRESSURE
B8	GENERATOR INDICATOR

GAUGE CLUSTER CONNECTOR A

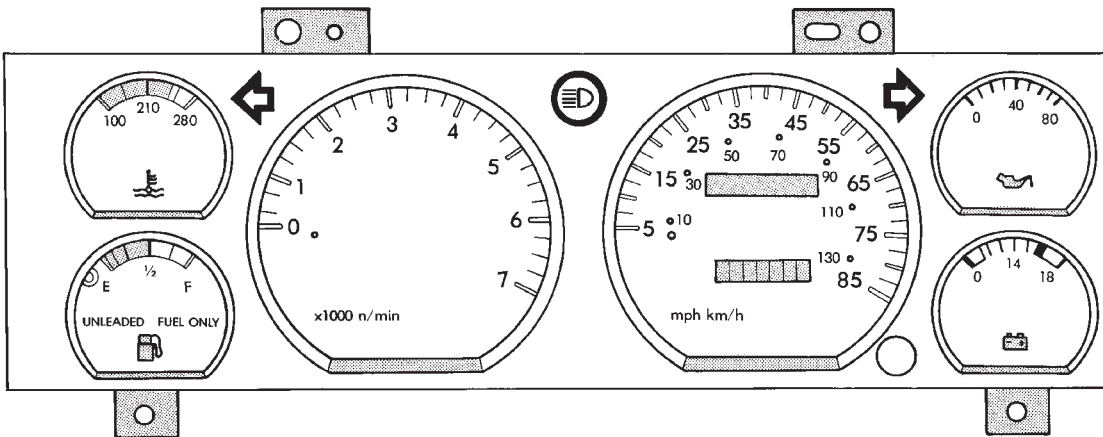


VIEWED FROM TERMINAL END

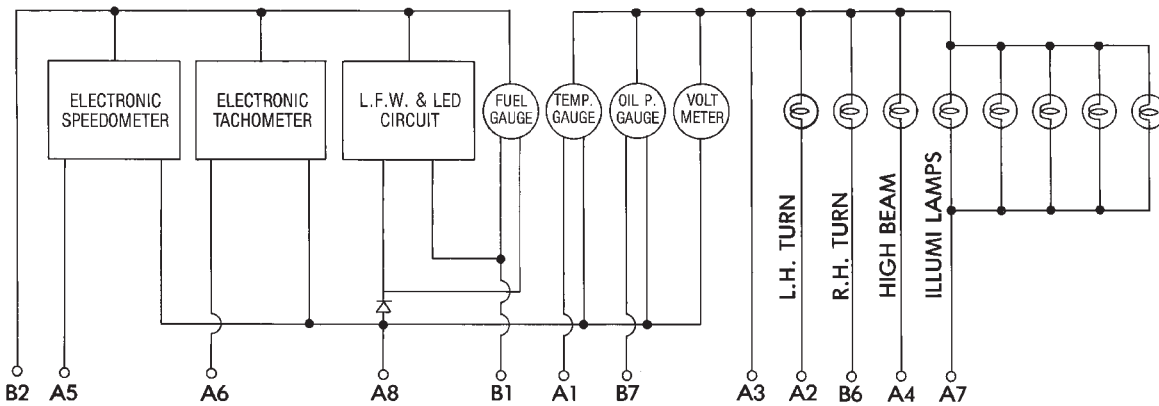


HIGH-LINE GAUGE CLUSTER (LHD)

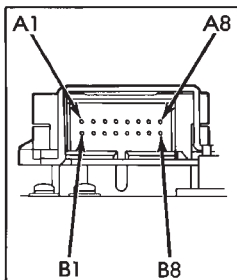
HIGH-LINE



GAUGE CLUSTER CIRCUIT SCHEMATIC



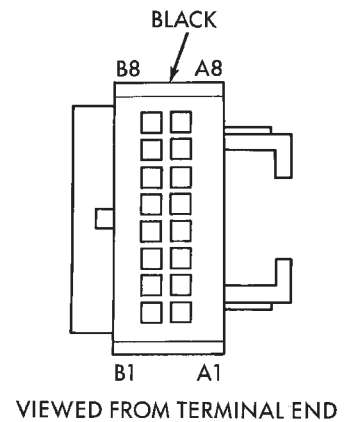
GAUGE CLUSTER PRINTED CIRCUIT TERMINALS



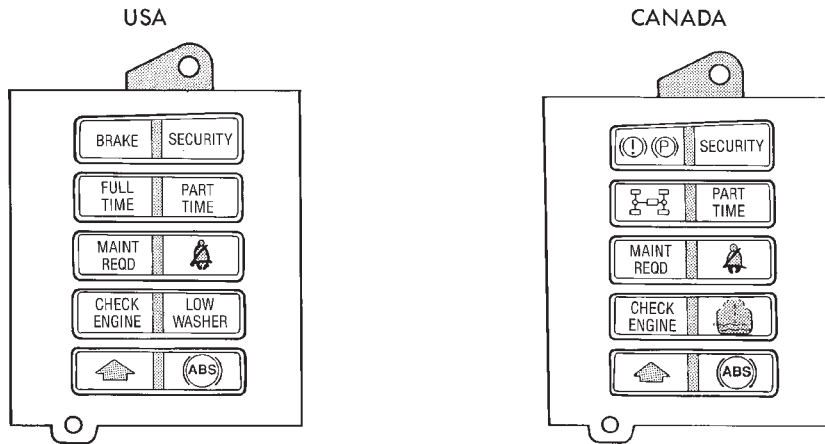
GAUGE CLUSTER LEGEND

NO.	IDENTIFICATION
A1	ENGINE COOLANT TEMP
A2	LEFT TURN INDICATOR
A3	GROUND
A4	HEADLAMP HIGH BEAM
A5	VEHICLE SPEED SENSOR
A6	TACHOMETER
A7	ILLUMINATION
A8	IGNITION
B1	FUEL GAUGE
B2	GROUND
B3	NOT USED
B4	NOT USED
B5	NOT USED
B6	RIGHT TURN INDICATOR
B7	ENGINE OIL PRESSURE
B8	GENERATOR INDICATOR

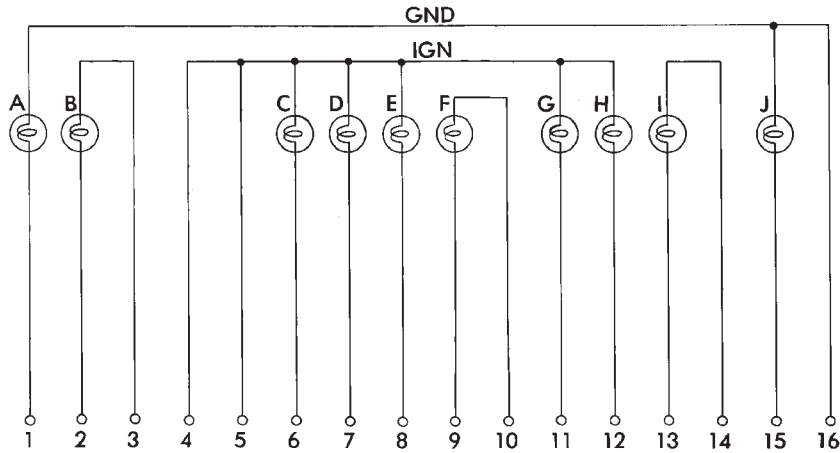
GAUGE CLUSTER CONNECTOR A



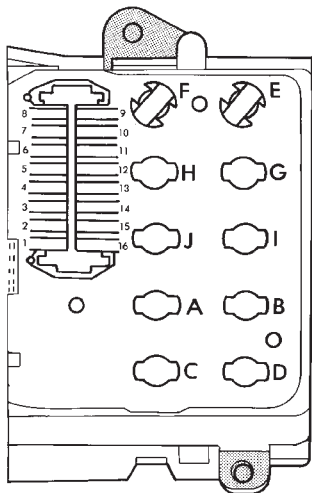
TELL-TALE CLUSTER (LHD)



TELL-TALE CLUSTER CIRCUIT SCHEMATIC



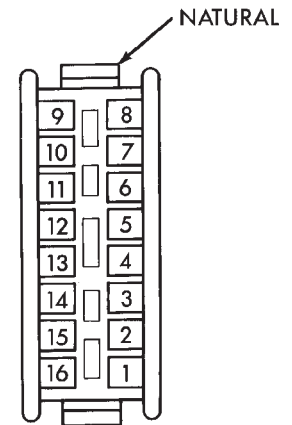
TELL-TALE CLUSTER PRINTED CIRCUIT



TELL-TALE CLUSTER LEGEND

NO.	LAMP	IDENTIFICATION
1	A	LOW WASHER
2	B	CHECK ENGINE
3	B	IGN
4	/	IGN
5	/	IGN
6	C	ABS
7	D	UP SHIFT
8	E	BRAKE
9	F	NOT USED
10	F	BATT
11	G	FULL TIME
12	H	PART TIME
13	I	NOT USED
14	I	IGN
15	J	SEAT BELT
16	/	GND

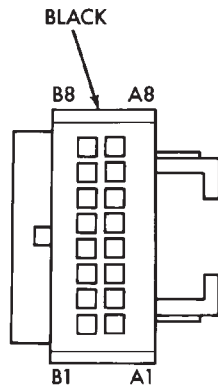
TELL-TALE CLUSTER CONNECTOR B



VIEWED FROM TERMINAL END

CLUSTER CONNECTORS (RHD)

GAUGE CLUSTER CONNECTOR A

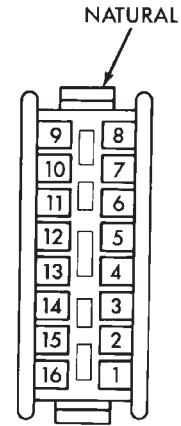


VIEWED FROM TERMINAL END

GAUGE CLUSTER LEGEND

NO.	IDENTIFICATION
A1	ENGINE COOLANT TEMP
A2	LEFT TURN INDICATOR
A3	GROUND
A4	HEADLAMP HIGH BEAM
A5	NOT USED
A6	ILLUMINATION
A7	IGNITION
A8	NOT USED
B1	FUEL GAUGE
B2	GROUND
B3	NOT USED
B4	NOT USED
B5	NOT USED
B6	VEHICLE SPEED SENSOR
B7	RIGHT TURN INDICATOR
B8	ENGINE OIL PRESSURE

TELL-TALE CLUSTER CONNECTOR B



VIEWED FROM TERMINAL END

TELL-TALE CLUSTER LEGEND

NO.	IDENTIFICATION
1	GROUND
2	SEAT BELT
3	IGN
4	NOT USED
5	PART TIME
6	FULL TIME
7	NOT USED
8	NOT USED
9	BRAKE
10	NOT USED
11	NOT USED
12	NOT USED
13	NOT USED
14	IGN
15	CHECK ENGINE
16	LOW WASHER

## INDICATOR LAMPS

If an individual indicator lamp is inoperative, see the diagnostic procedure under the heading for that lamp. If more than one indicator lamp or a combination of lamps and gauges in the gauge area of the instrument cluster is inoperative, see Gauges in this section for diagnosis.

If more than one indicator lamp in the tell-tale area of the cluster is inoperative, perform the following:

(1) Check fuse 17 (fuse 26 - RHD) in the fuseblock module. If OK, go to next step. If not OK, replace fuse.

(2) Check for battery voltage at fuse 17 (fuse 26 - RHD) with ignition switch in ON position. If OK, go to next step. If not OK, repair circuit to ignition switch and/or refer to Group 8D - Ignition Systems for testing of ignition switch.

(3) Turn ignition switch to OFF. Disconnect battery negative cable. Remove instrument cluster bezel and cluster assembly. Unplug cluster (tell-tale) connector B.

(4) Connect battery negative cable. Turn ignition switch to ON. Check for battery voltage at cavities 3, 4, and 14 (cavities 3 and 14 - RHD) of cluster connector B. If OK, go to next step. If not OK, repair open circuit to fuse 17 (fuse 26 - RHD) as required.

(5) Turn ignition switch to OFF. Disconnect battery negative cable. Probe cavity 16 (cavity 1 - RHD) of cluster connector B. Check for continuity to a good ground. There should be continuity. If OK, replace cluster tell-tale printed circuit. If not OK, repair open circuit to ground as required.

## ANTI-LOCK BRAKE SYSTEM LAMP

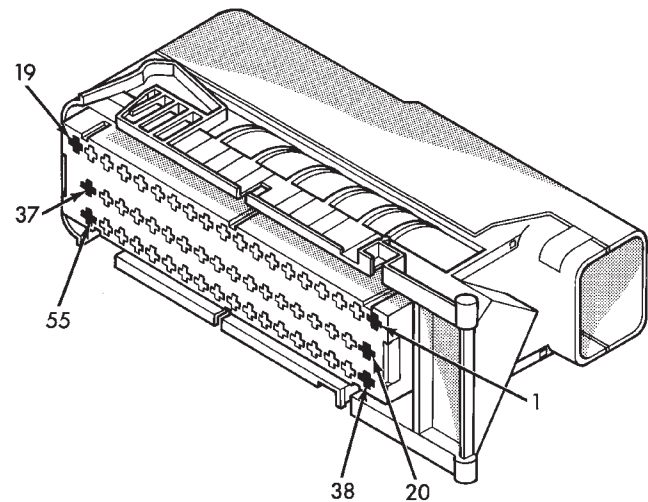
The diagnosis found here addresses an inoperative lamp condition. If the ABS lamp stays on with the ignition switch in the ON position, or comes on and stays on while driving, refer to Group 5 - Brakes for diagnosis. If no ABS problem is found, the following procedure will help locate a short or open in the ABS lamp circuit.

(1) Disconnect battery negative cable. Remove instrument cluster bezel and cluster assembly. Disconnect ABS control module connector.

(2) Install a jumper wire between cavity 6 of cluster (tell-tale) connector B and a good ground. Connect battery negative cable and turn ignition switch to ON. Lamp should light. If OK, remove jumper wire and go to next step. If not OK, replace bulb.

(3) Turn ignition switch to OFF. Disconnect battery negative cable and unplug cluster connector B. Check for continuity between cavity 6 of cluster connector B and a good ground. There should be no continuity. If OK, go to next step. If not OK, repair short circuit as required.

(4) Check continuity between cavity 6 of cluster connector B and cavity 52 of ABS control module connector (Fig. 6). There should be continuity. If OK, refer to Group 5 - Brakes for diagnosis of ABS control module. If not OK, repair open circuit as required.



NO.	IDENTIFICATION
52	ANTI-LOCK BRAKE SYSTEM LAMP

J958E-9

**Fig. 6 ABS Control Module Connector**

## BRAKE WARNING LAMP

The diagnosis found here addresses an inoperative lamp condition. If the brake warning lamp stays on with the ignition switch in the ON position and the parking brake released, refer to Group 5 - Brakes for diagnosis. If no service brake or parking brake problem is found, the following procedure will help locate a short circuit or faulty switch.

(1) Unplug parking brake switch connector. Turn ignition switch to START position. Lamp should light. Release ignition switch to ON position. Lamp should go OFF. If OK, go to step 10. If not OK, go to next step.

(2) Unplug brake warning switch connector. Install a jumper wire between two cavities of connector. Turn ignition switch to START. Lamp should light. Remove jumper wire and lamp should go off. If OK, replace brake warning switch. If not OK, remove jumper wire and go to next step.

(3) Turn ignition switch to ON position. Install a jumper wire between cavity B (cavity A - RHD) of brake warning switch connector and a good ground. Lamp should light. If OK, go to step 5. If not OK, go to next step.

(4) Turn ignition switch to OFF. Remove jumper wire and disconnect battery negative cable. Remove instrument cluster bezel and cluster assembly. Install a jumper wire between cavity 8 (cavity 9 - RHD) of cluster (tell-tale) connector B and a good ground.

Connect battery negative cable and turn ignition switch to ON. Lamp should light. If OK, repair open circuit to brake warning switch. If not OK, replace bulb.

(5) Turn ignition switch to OFF and remove jumper wire. Disconnect battery negative cable. Check for continuity between cavity A (cavity B - RHD) of brake warning switch connector and a good ground with ignition switch in START position. There should be continuity. If not OK, go to next step.

(6) Turn ignition switch to OFF and remove jumper wire. Disconnect battery negative cable. Unplug ignition switch connector. Check for continuity between ignition switch connector cavity 3 and a good ground. There should be no continuity. If OK, go to next step. If not OK, repair short circuit between ignition switch and brake warning switch connectors as required.

(7) Check for continuity between ignition switch connector cavity 3 and brake warning switch connector cavity A (cavity B - RHD). There should be continuity. If OK, go to next step. If not OK, repair open circuit as required.

(8) Check for continuity between metal steering column jacket and a good ground. There should be continuity. If OK, go to next step. If not OK, refer to Group 19 - Steering to check steering column ground clip installation.

(9) Turn ignition switch to START position and hold there. Check for continuity between terminal 3 of ignition switch and a good ground. There should be continuity. If not OK, replace ignition switch.

(10) Unplug brake warning switch connector. Check for continuity between parking brake switch connector and a good ground. There should be no continuity. If OK, go to next step. If not OK, repair short circuit as required.

(11) Check for continuity between parking brake switch connector and cavity B (cavity A - RHD) of brake warning switch connector. There should be continuity. If OK, replace parking brake switch. If not OK, repair open circuit to brake warning switch as required.

#### COOLANT TEMPERATURE WARNING LAMP

The diagnosis found here addresses an inoperative lamp condition. If the problem being diagnosed is related to lamp accuracy, be certain to confirm that problem is with lamp and not with cooling system performance. Actual engine coolant temperature should be checked with a test gauge or thermometer before proceeding with lamp diagnosis. Refer to Group 7 - Cooling System for more information.

(1) Turn ignition switch to START position. Lamp should light. If OK, go to next step. If not OK, go to step 3.

(2) Turn ignition switch to ON. Disconnect coolant temperature switch connector (Fig. 1). Jump switch connector to ground. Lamp should light. If OK, replace switch. If not OK, go to next step.

(3) Turn ignition switch to OFF. Disconnect battery negative cable. Unplug coolant temperature switch connector. Remove instrument cluster bezel and cluster assembly. Disconnect cluster connector A and probe cavity A1. Check for continuity to a good ground. There should be no continuity. If OK, go to next step. If not OK, repair short circuit to coolant temperature switch or ignition switch as required.

(4) Connect cluster connector A to cluster. Install a jumper wire from cavity A1 of cluster connector A to a good ground. Connect battery negative cable and turn ignition switch to ON. Lamp should light. If OK, repair open circuit to coolant temperature switch or ignition switch as required. If not OK, replace bulb.

#### FOUR-WHEEL DRIVE INDICATOR LAMPS

(1) Apply parking brake, start engine, vehicle in 4WD Lock or 4WD.

(2) Unplug switch and touch harness side of wire to ground. Lamp should light. If OK, check switch operation, replace if bad. If bulb is OK, repair open to indicator.

#### GENERATOR WARNING LAMP

(1) Disconnect battery negative cable and unplug PCM connector. Install a jumper wire between cavity 36 of PCM connector (Fig. 5) and a good ground. Connect battery negative cable and turn ignition switch to ON. Lamp should light. Unplug jumper wire and lamp should go off. If OK, refer to Powertrain Diagnostic Procedures to check PCM. If not OK, go to next step.

(2) Turn ignition switch to OFF and disconnect battery negative cable. Remove instrument cluster bezel and cluster assembly. Install a jumper wire between cavity B8 of cluster connector A and a good ground. Connect battery negative cable and turn ignition switch to ON. Lamp should light. If OK, go to next step. If not OK, replace bulb.

(3) Turn ignition switch to OFF and disconnect battery negative cable. Unplug cluster connector A. Probe cavity B8 of cluster connector A and check for continuity to a good ground. There should be no continuity. If OK, go to next step. If not OK, repair short circuit as required.

(4) Check for continuity between cavity B8 of cluster connector A and cavity 36 of PCM connector. There should be continuity. If not OK, repair open circuit as required.

#### HEADLAMP HIGH BEAM INDICATOR LAMP

(1) Check that headlamp high beams are functional. If OK, go to next step. If not OK, refer to Group 8L - Lamps for diagnosis of headlamp system.

(2) Disconnect battery negative cable. Remove instrument cluster bezel and cluster assembly. Unplug cluster connector A. Connect battery negative cable. Turn headlamps on and select high beam. Check for battery voltage at cavity A4 of cluster connector A. If OK, replace indicator bulb. If not OK, repair circuit to headlamp dimmer (multi-function) switch as required.

#### LOW FUEL WARNING LAMP

(1) Check that fuel gauge is operating as designed. See Fuel Gauge Calibration chart in Specifications. If OK, go to next step. If not OK, see Fuel Gauge in this section for diagnosis.

(2) With at least 10 gallons of fuel in fuel tank, unplug fuel tank sending unit connector. Turn ignition switch to ON and wait 10 seconds. Lamp (LED) should light. Reconnect fuel tank sending unit and wait 20 seconds. Lamp (LED) should go off. If not OK, replace low fuel warning lamp module.

#### LOW OIL PRESSURE WARNING LAMP

The diagnosis found here addresses an inoperative lamp condition. If the problem being diagnosed is related to lamp accuracy, be certain to confirm that problem is with lamp and not with engine oiling system. Actual engine oil pressure should be checked with a test gauge before you proceed with lamp diagnosis. Refer to Group 9 - Engines for more information.

(1) Turn ignition switch to ON. Lamp should light. Start engine. Lamp should go off. If not OK, turn engine off and go to next step.

(2) Unplug connector at oil pressure switch (Fig. 3). The switch is located on right side of engine block. On 2.5L engine, it is just forward of ignition distributor and just to the rear of generator mounting bracket. On 4.0L engine, it is just to the rear of ignition distributor and above oil filter adapter. Install a jumper wire from connector to a good ground. Turn ignition switch to ON. Lamp should light. Unplug jumper wire. Lamp should go out. If OK, replace oil pressure switch. If not OK, go to next step.

(3) Turn ignition switch to OFF. Disconnect battery negative cable. Remove instrument cluster bezel and cluster assembly. Install a jumper wire from cavity B7 (cavity B8 - RHD) of cluster connector A to a good ground. Connect battery negative cable and turn ignition switch to ON. Lamp should light. If OK, go to next step. If not OK, replace lamp bulb.

(4) Turn ignition switch to OFF. Disconnect battery negative cable. Unplug instrument cluster connector A. Check continuity between cavity B7 (cavity B8 - RHD) of cluster connector A and a good ground. There should be no continuity. If OK, go to next step. If not OK, repair short circuit as required.

(5) Check continuity between cavity B7 (cavity B8 - RHD) of cluster connector A and oil pressure switch

connector. There should be continuity. If not OK, repair open circuit as required.

#### LOW WASHER FLUID WARNING LAMP

(1) Unplug washer fluid level switch connector. Turn ignition switch to ON. Check for battery voltage at connector cavity A. If OK, turn ignition switch to OFF and go to next step. If not OK, repair open circuit to fuse F6 in PDC.

(2) Install a jumper wire from cavity A to cavity B of washer fluid level switch connector. Turn ignition switch to ON. Lamp should light. Unplug jumper and lamp should go OFF. If OK, replace washer fluid level switch. If not OK, go to next step.

(3) Turn ignition switch to OFF. Disconnect battery negative cable. Remove instrument cluster bezel and cluster assembly. Unplug instrument cluster (tell-tale) connector B. Check continuity between cavity 16 (cavity 1 - RHD) of cluster connector B and a good ground. There should be continuity. If OK, plug cluster connector B back into cluster and go to next step. If not OK, repair open circuit to ground as required.

(4) Connect battery negative cable. Install a jumper wire from a 12-volt battery feed to cavity 1 (cavity 16 - RHD) of cluster connector B. Lamp should light. If OK, go to next step. If not OK, replace bulb.

(5) Disconnect battery negative cable. Unplug cluster connector B. Check continuity between cavity 1 (cavity 16 - RHD) of cluster connector B and a good ground. There should be no continuity. If OK, go to next step. If not OK, repair short circuit to switch as required.

(6) Check continuity between cavity 1 (cavity 16 - RHD) of cluster connector B and cavity B of washer fluid level switch connector. There should be continuity. If not OK, repair open circuit to switch as required.

#### MALFUNCTION INDICATOR LAMP

The diagnosis found here addresses an inoperative lamp condition. If the lamp comes on and stays on with engine running, refer to Group 14 - Fuel System for diagnosis. If no fuel or emission system problem is found, the following procedure will help locate a short or open in the lamp circuit.

(1) Disconnect battery negative cable. Unplug PCM connector. Install a jumper wire from cavity 32 of PCM connector (Fig. 5) to a good ground. Connect battery negative cable. Turn ignition switch to ON. Lamp should light. Remove jumper wire and lamp should go OFF. If OK, refer to Powertrain Diagnostic Procedures to check PCM. If not OK, go to next step.

(2) Turn ignition switch to OFF. Disconnect battery negative cable. Remove instrument cluster bezel and cluster assembly. Install a jumper wire from cavity 2 (cavity 15 - RHD) of cluster (tell-tale) connector B to a good ground. Connect battery negative cable. Turn

ignition switch to ON. Lamp should light. If OK, go to next step. If not OK, replace bulb.

(3) Turn ignition switch to OFF. Disconnect battery negative cable. Unplug cluster connector B. Check for continuity between cavity 2 (cavity 15 - RHD) of cluster connector B and a good ground. There should be no continuity. If OK, go to next step. If not OK, repair short circuit to PCM as required.

(4) Check continuity between cavity 2 (cavity 15 - RHD) of cluster connector B and cavity 32 of PCM connector. There should be continuity. If not OK, repair open circuit to PCM as required.

#### SEAT BELT REMINDER LAMP

(1) Refer to Group 8U - Chime/Buzzer Warning Systems to check chime/buzzer module operation. If OK, go to next step. If not OK, replace chime/buzzer module.

(2) Disconnect battery negative cable. Remove instrument cluster bezel and cluster assembly. Unplug cluster (tell-tale) connector B. Check for continuity between cavity 16 (cavity 1 - RHD) of cluster connector B and a good ground. There should be continuity. If OK, plug cluster connector B back into cluster and go to next step. If not OK, repair open circuit to ground as required.

(3) Connect battery negative cable. Install a jumper wire between a 12-volt battery feed and cavity 15 (cavity 2 - RHD) of cluster connector B. Lamp should light. If OK, go to next step. If not OK, replace bulb.

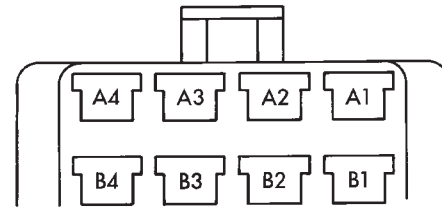
(4) Disconnect battery negative cable. Unplug chime/buzzer module from fuseblock module (connector near fuseblock module - RHD). Unplug cluster connector B. Check for continuity between cavity 15 (cavity 2 - RHD) of cluster connector B and a good ground. There should be no continuity. If OK, go to next step. If not OK, repair short circuit to chime/buzzer module as required.

(5) Check continuity between cavity 15 (cavity 2 - RHD) of cluster connector B and cavity for terminal A3 of chime/buzzer module (Fig. 7) in fuseblock module (connector near fuseblock module - RHD). There should be continuity. If not OK, repair open circuit to chime/buzzer module as required.

#### TURN SIGNAL INDICATOR LAMPS

(1) Disconnect battery negative cable. Remove instrument cluster bezel and cluster assembly. Probe cavity A3 of cluster connector A. Check for continuity to a good ground. There should be continuity. If OK, go to next step. If not OK, repair open circuit to ground.

(2) Connect battery negative cable. Install a jumper wire from cavity A2 (left indicator) or cavity B6 (cavity B7 - RHD)(right indicator) of cluster connector A to a 12-volt battery feed. Lamp should light. If OK, continue to next step. If not OK, replace bulb.



VIEWED FROM TERMINAL END

NO.	IDENTIFICATION
A3	SEAT BELT REMINDER LAMP

J958E-10

Fig. 7 Chime/Buzzer Module Receptacle

(3) Disconnect battery negative cable. Check for continuity between cavity A2 (left indicator) or cavity B6 (cavity B7 - RHD)(right indicator) of cluster connector A and cavity A1 (cavity 11 - RHD)(left front turn signal) or cavity F2 (cavity 10 - RHD)(right front turn signal) of bulkhead disconnect (dash to instrument panel connector B - RHD). There should be continuity. If OK, refer to Group 8J - Turn Signal and Hazard Warning Systems for further diagnosis. If not OK, repair open circuit as required.

#### UPSHIFT INDICATOR LAMP

(1) Disconnect battery negative cable. Unplug PCM connector. Connect battery negative cable. Turn ignition switch to ON. Install a jumper wire from cavity 54 of PCM connector (Fig. 5) to a good ground. Lamp should light. Remove jumper from ground. Lamp should go off. If OK, refer to Powertrain Diagnostic Procedures manual to diagnose PCM. If not OK, turn ignition switch to OFF and go to next step.

(2) Disconnect battery negative cable. Remove instrument cluster bezel and cluster assembly. Install a jumper wire from cavity 7 of cluster (tell-tale) connector B to a good ground. Connect battery negative cable. Turn ignition switch to ON. Lamp should light. If OK, go to next step. If not OK, replace bulb.

(3) Turn ignition switch to OFF. Disconnect battery negative cable. Unplug cluster connector B. Check for continuity between cavity 7 of cluster connector B and a good ground. There should be no continuity. If OK, go to next step. If not OK, repair short circuit as required.

(4) Check for continuity between cavity 7 of cluster connector B and cavity 54 of PCM connector. There should be continuity. If not OK, repair open circuit as required.

### CLUSTER ILLUMINATION LAMPS

(1) Check fuse 19 (fuse 25 - RHD) in fuseblock module. If OK, go to next step. If not OK, replace fuse.

(2) Turn park lamps on at headlamp switch. Rotate headlamp switch knob counterclockwise to just before interior lamps detent. Check for battery voltage at fuse 19 (fuse 25 - RHD) in fuseblock module. Rotate headlamp switch clockwise while observing test voltmeter. Reading should go from battery voltage to zero volts. If OK, go to next step. If not OK, repair open circuit to headlamp switch or refer to Group 8L - Lamps to diagnose headlamp switch.

(3) Disconnect battery negative cable. Remove instrument cluster bezel and cluster assembly. Unplug cluster connector A. Connect battery negative cable.

Turn park lamps on at headlamp switch. Rotate headlamp switch knob counterclockwise to just before interior lamps detent. Check for battery voltage at cavity A7 (cavity A6 - RHD) of cluster connector A. If OK, go to next step. If not OK, repair open circuit to fuse as required.

(4) Turn park lamps off. Disconnect battery negative cable. Remove fuse 19 (fuse 25 - RHD) from fuseblock module. Probe cavity A7 (cavity A6 - RHD) of cluster connector A. Check for continuity to a good ground. There should be no continuity. If OK, go to next step. If not OK, repair short circuit as required.

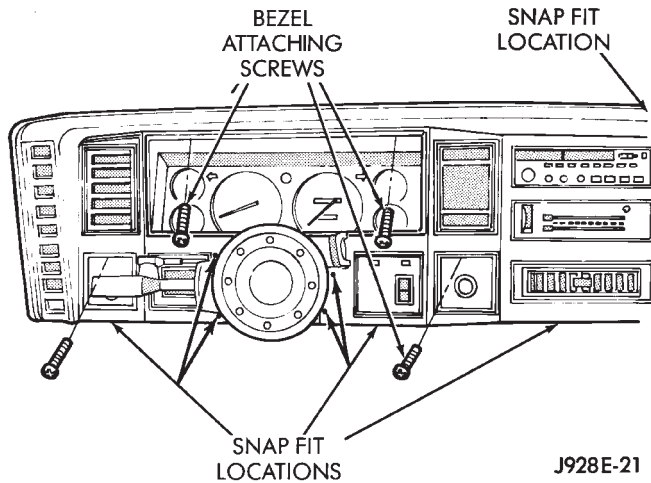
(5) Probe cavity A3 of cluster connector A. Check for continuity to ground. There should be continuity. If not OK, repair open circuit as required.



SERVICE PROCEDURES

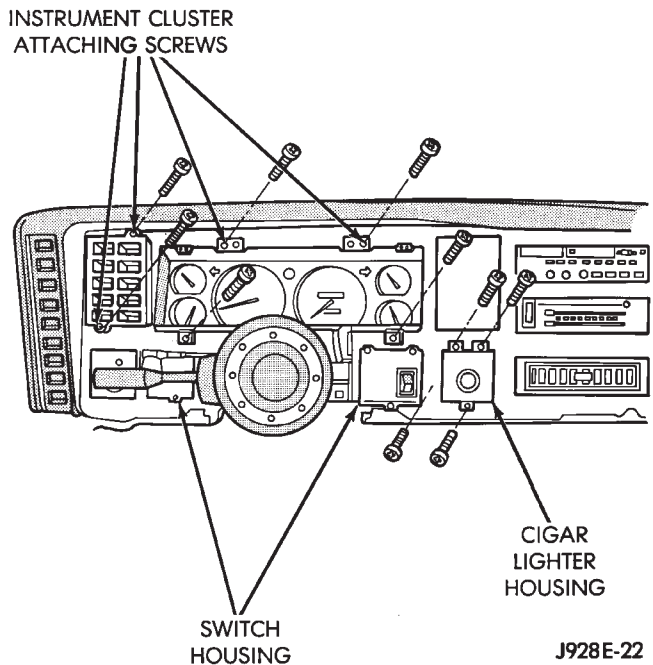
**CLUSTER ASSEMBLY REMOVE/INSTALL**

- (1) Disconnect battery negative cable.
- (2) Remove upper and lower steering column shrouds and steering column to instrument panel bezel gap hider. If equipped with tilt steering, apply tape to tilt mechanism on top of steering column to protect instrument panel bezel from damage during removal.
- (3) Remove 4 instrument cluster bezel attaching screws and remove bezel. Bezel is snap fit at locations shown (Fig. 8).



**Fig. 8 Cluster Bezel Remove/Install**

- (4) Remove cigar lighter housing attaching screws (Fig. 9).
- (5) If equipped, remove switch housing(s) attaching screws (Fig. 9).

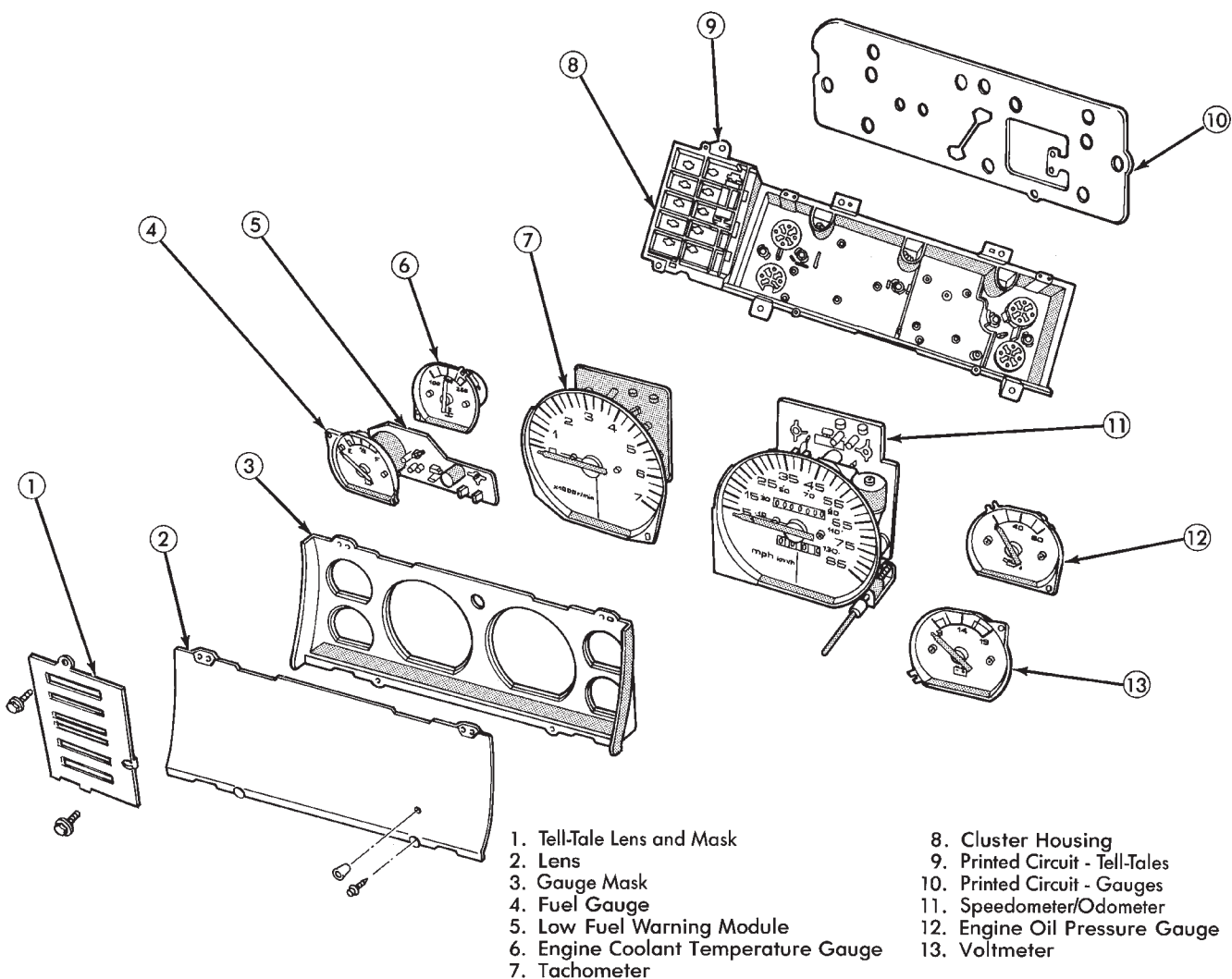


**Fig. 9 Cluster Assembly Remove/Install**

- (6) Remove cluster assembly attaching screws (Fig. 9).
- (7) Pull cluster assembly far enough out to disconnect 2 cluster harness connectors from the rear. Remove cluster assembly.
- (8) Reverse removal procedures to install.

**GAUGES REMOVE/INSTALL**

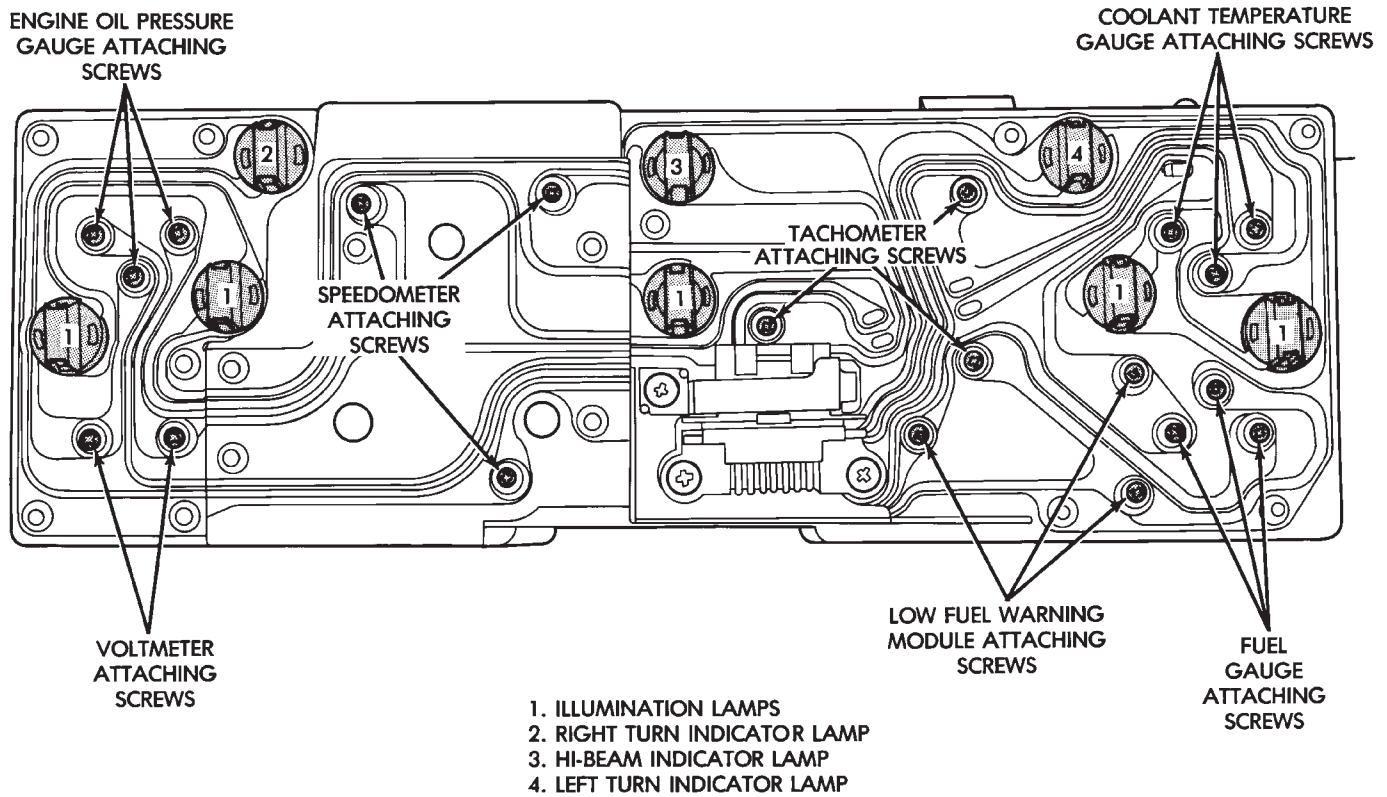
- (1) Remove cluster assembly as described in Cluster Assembly Remove/Install.



J958E-11

**Fig. 10 Instrument Cluster**

(2) If equipped with trip odometer, gently pull knob off trip odometer push pin. Remove cluster lens and mask (Fig. 10).



J948E-47

**Fig. 11 Printed Circuit Remove/Install**

(3) Remove gauge attaching screws from rear of cluster housing (Fig. 11). Remove gauge from front of housing.

(4) Reverse removal procedures to install.

**PRINTED CIRCUIT REMOVE/INSTALL**

**GAUGE CLUSTER**

(1) Remove cluster assembly as described in Cluster Assembly Remove/Install.

(2) Remove all gauges as described in Gauges Remove/Install.

(3) Remove screw holding the cluster connector retaining strap to cluster housing. Remove strap and pivot connector down (Figs. 12 and 13).

(4) Remove all lamp holders from printed circuit.

(5) Remove printed circuit including connector.

(6) Reverse removal procedures to install.

**TELL-TALE CLUSTER**

(1) Remove cluster assembly as described in Cluster Assembly Remove/Install.

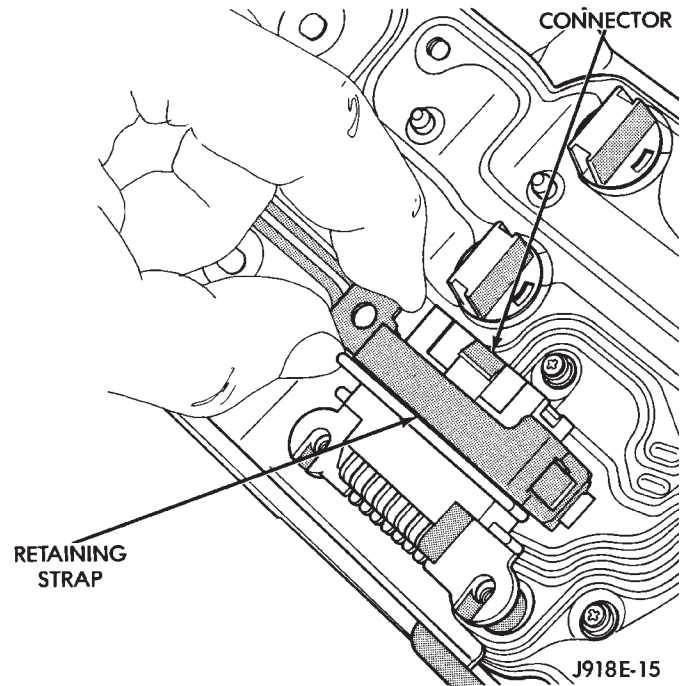
(2) Remove all lamp holders from printed circuit.

(3) Remove printed circuit.

(4) Reverse removal procedures to install.

**HEADLAMP SWITCH REMOVE/INSTALL**

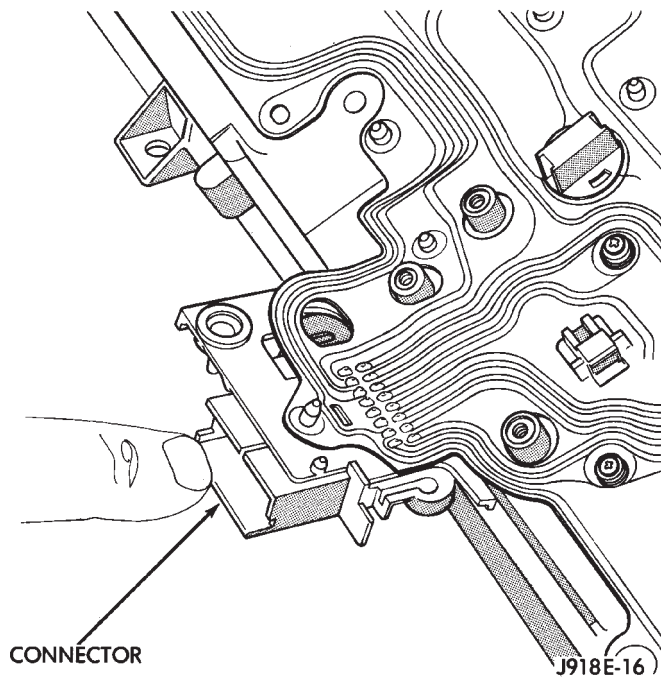
(1) Disconnect battery negative cable.



J918E-15

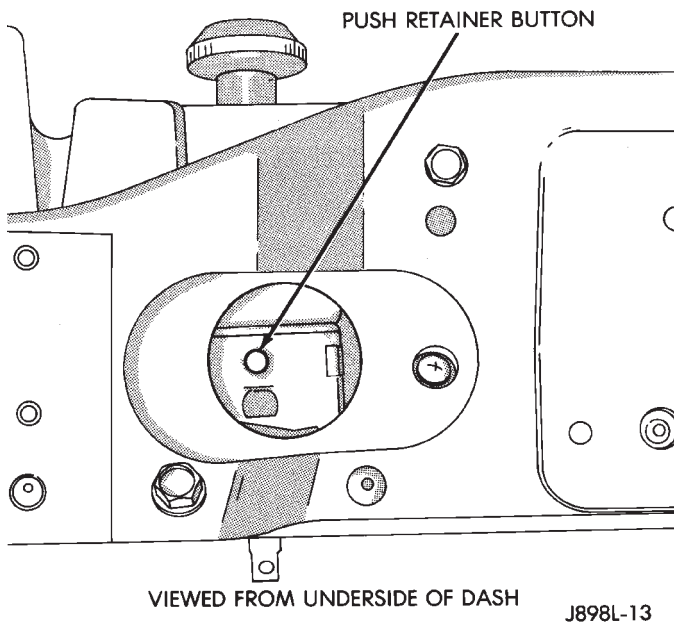
**Fig. 12 Cluster Connector Retaining Strap**

(2) Place headlamp switch control knob in the headlamp ON position.



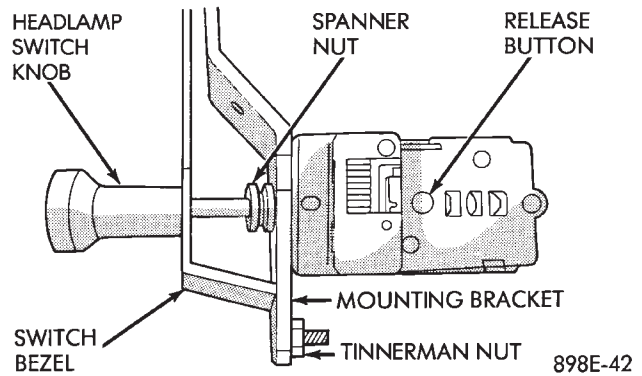
**Fig. 13 Printed Circuit And Cluster Connector**

(3) Reach under the instrument panel and depress the switch shaft release/retainer button (Fig. 14). Pull the switch control knob and shaft outward.



**Fig. 14 Headlamp Switch Knob And Shaft Remove/Install**

(4) Remove the headlamp switch retaining nut from the front of the instrument panel (Fig. 15).



**Fig. 15 Headlamp Switch Remove/Install**

(5) Disconnect the wire harness connector from the switch.

(6) Remove the headlamp switch from the instrument panel.

(7) Reverse removal procedures to install.

### INSTRUMENT PANEL REMOVE/INSTALL

(1) Disconnect battery negative cable.

(2) Remove the following (Fig. 16):

- parking brake release handle
- lower heat/AC duct below steering column
- ash receiver
- lower instrument panel
- cluster bezel
- cluster assembly
- radio
- climate control panel
- instrument panel switches
- headlamp switch
- antenna connector
- blower motor resistors
- ground lead
- unplug glove box lamp
- defroster cowl outlet panel

**Remove driver's side heat/AC outlet to gain access to driver's side defroster cowl outlet panel retaining clip to aid in removal (Fig. 17).**

- instrument panel attaching bolts
- steering column attaching bolts
- instrument panel assembly.

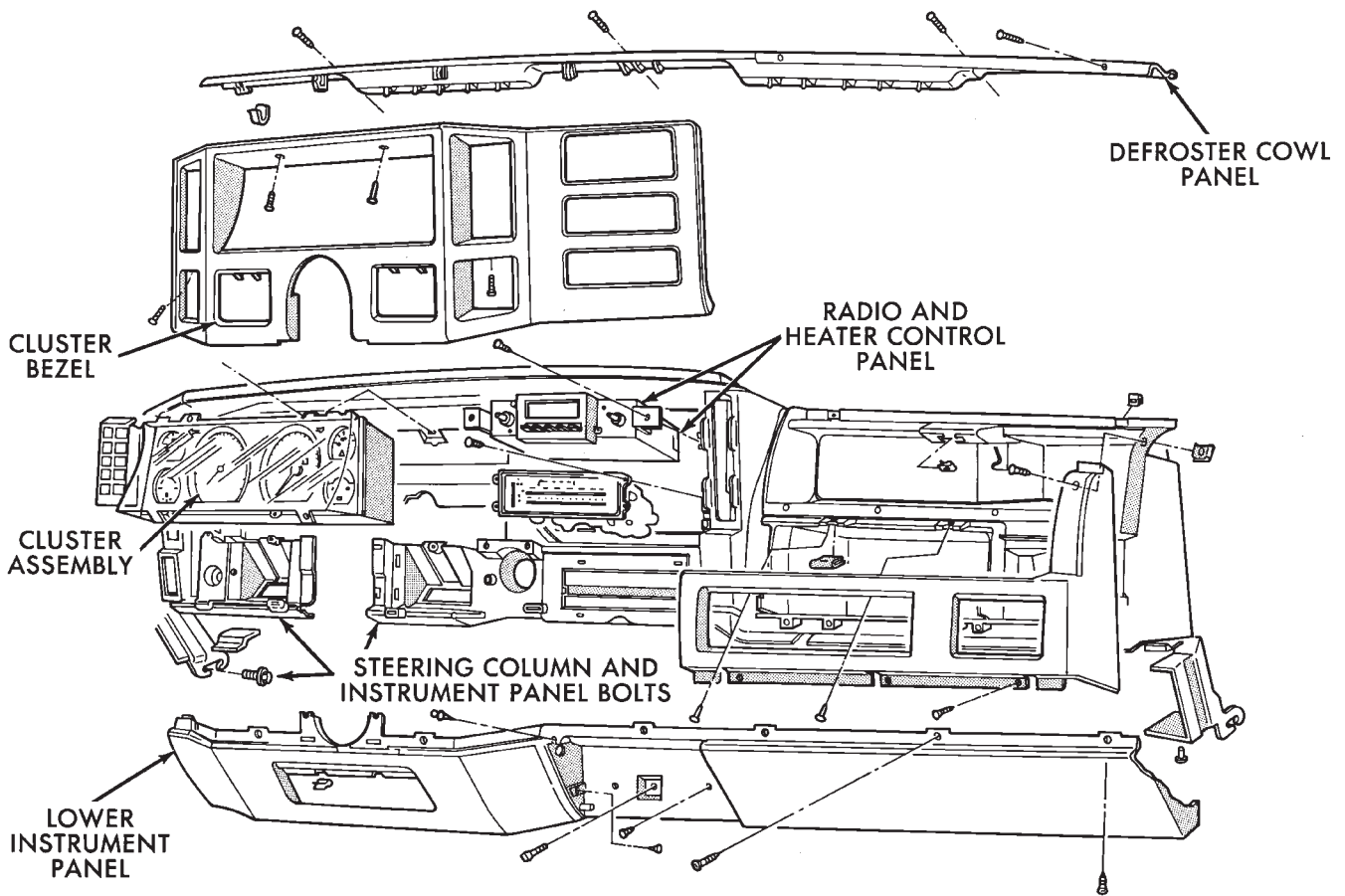
**The instrument panel wiring harness is attached to the back of the instrument panel assembly and must be installed correctly.**

(3) To install instrument panel, position instrument panel assembly on side mounting bolts (Fig. 18).

(4) Route wiring harnesses and secure instrument panel assembly mounting points.

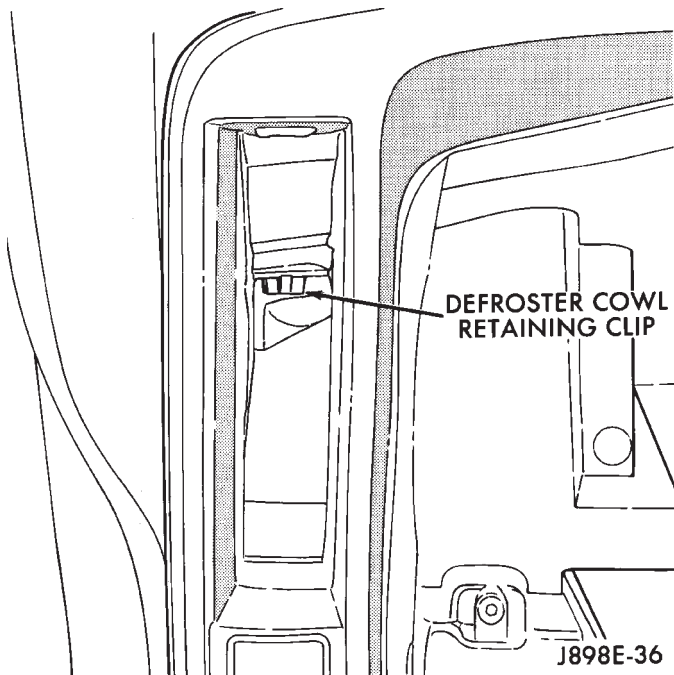
(5) Connect tube to lap cooler.

(6) Reverse removal procedures to complete installation.



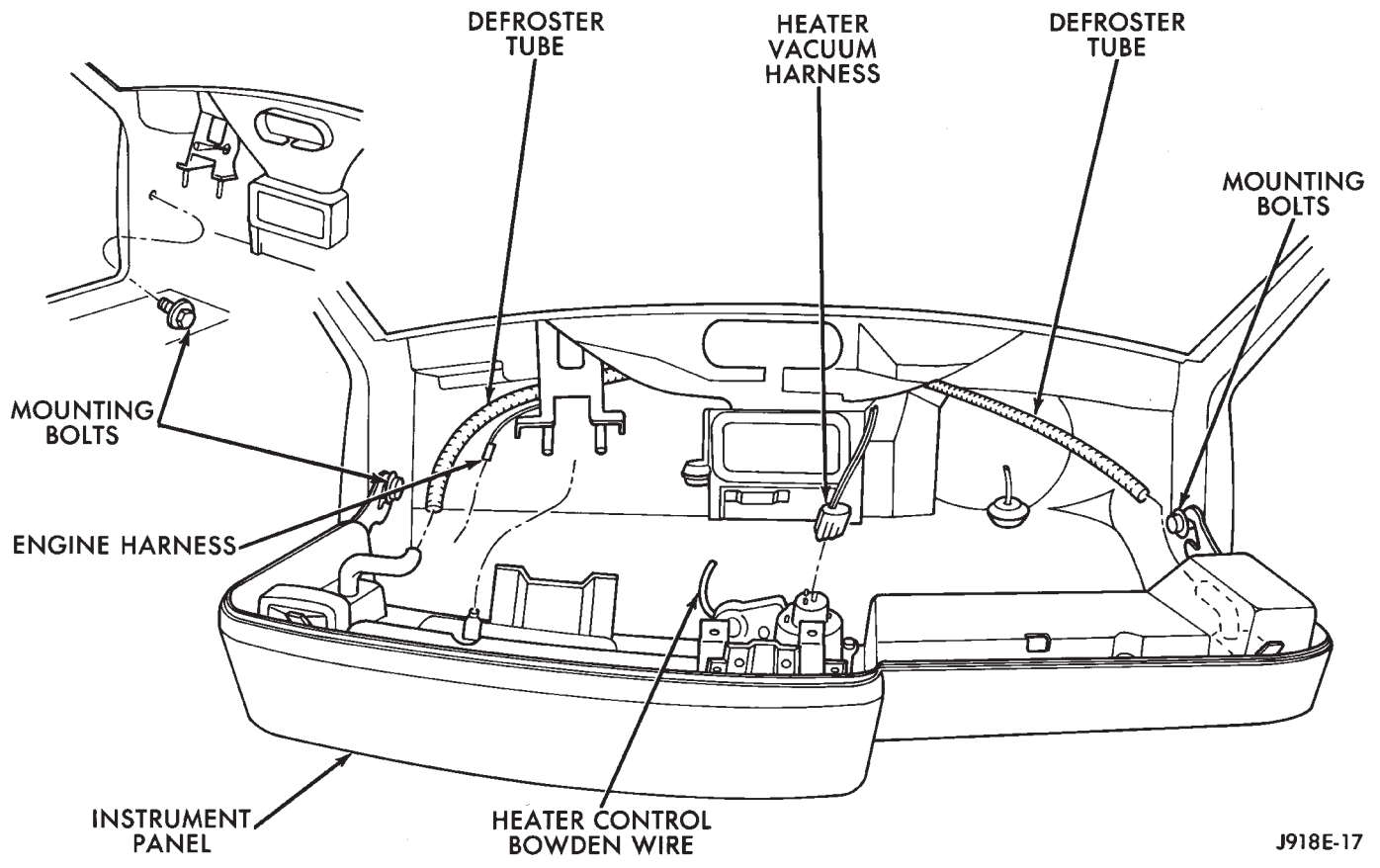
J928E-34

Fig. 16 Instrument Panel Exploded View



J898E-36

Fig. 17 Driver's Side Defroster Cowl Retaining Clip



*Fig. 18 Instrument Panel Install*

**SPECIFICATIONS**  
*GAUGE CLUSTER*

**OIL PRESSURE GAUGE CALIBRATION**

<b>POINTER POSITION</b>	<b>RESISTANCE</b>
0 psi Grad. $\pm 2^\circ$	1 ohm
40 psi Grad. $\pm 3\frac{1}{2}^\circ$	46 ohms
80 psi Grad. $\pm 3^\circ$	87 ohms

**VOLTMETER CALIBRATION**

<b>VOLTAGE INPUT</b>	<b>POINTER POSITION</b>
12V	12V Grad. $\pm 6^\circ$
16V	16V Grad. $\pm 3^\circ$

**TEMPERATURE GAUGE CALIBRATION**

<b>POINTER POSITION</b>	<b>RESISTANCE</b>
100°F Grad. $\pm 3\frac{1}{2}^\circ$	1365 ohms
220°F Grad. $\pm 2\frac{1}{2}^\circ$	93.5 ohms
260°F Grad. $\pm 2\frac{1}{2}^\circ$	55.1 ohms

**TACHOMETER CALIBRATION**

<b>ENGINE</b>	<b>FREQUENCY</b>	<b>INDICATION</b>
4 & 6 CYLINDER	66.7 HZ	2000 RPM $\pm 140$
	166.7 HZ	5000 RPM $\pm 140$

**FUEL GAUGE CALIBRATION**

<b>POINTER POSITION</b>	<b>RESISTANCE</b>
Empty Grad. $+0^\circ -4^\circ$	105 ohm
1/2 Full Grad. $\pm 3\frac{1}{2}^\circ$	33 ohms
Full Grad. $+6^\circ -0^\circ$	5 ohms

**SPEEDOMETER CALIBRATION**

<b>ENGINE</b>	<b>FREQUENCY</b>	<b>INDICATION</b>
4 & 6 CYLINDER	44.4 HZ	20 mph $-1.5$ $+4.5$
		55 mph $-.3$ $+3.3$
	166.5 HZ	75 mph $-.3$ $+3.3$

J918E-9X

# INSTRUMENT PANEL AND GAUGES—YJ

## CONTENTS

	page		page
INSTRUMENT PANEL AND GAUGES—YJ	22	SERVICE PROCEDURES	31
DIAGNOSIS	23	SPECIFICATIONS	39
GENERAL INFORMATION	20		

## GENERAL INFORMATION

Following are general descriptions of major instrument panel components. Refer to Group 8W - Wiring Diagrams for complete circuit descriptions and diagrams.

### INSTRUMENT PANEL

Modular instrument panel construction allows all gauges and controls to be serviced from the front of the panel. In addition, most instrument panel wiring and heater components can be accessed without complete instrument panel removal.

Removal of the left instrument cluster bezel allows access to the main cluster assembly and most switches. Removal of the center cluster bezel allows access to the gauge package cluster assembly, the heater controls, and the radio. Removal of the cluster assemblies allows access to the individual gauges, illumination and indicator lamp bulbs, printed circuits, and most wiring.

### INSTRUMENT CLUSTERS

The instrument cluster used on YJ (Wrangler) models consists of two separate assemblies. The main cluster assembly is located on the left side of the instrument panel, centered over the steering column opening. The gauge package cluster assembly is located near the center of the instrument panel. Each cluster assembly is served by a separate printed circuit and wiring connector. Some variations of each cluster exist due to optional equipment and regulatory requirements.

The main cluster assembly includes a speedometer/odometer/trip odometer and a tachometer. It also includes provisions for the following indicator lamps:

- anti-lock brake system lamp
- brake warning lamp
- headlamp high beam indicator lamp
- malfunction indicator (Check Engine) lamp
- seat belt reminder lamp

- turn signal indicator lamps
- upshift indicator lamp.

The gauge package cluster assembly includes a four-wheel drive indicator lamp and the following gauges:

- coolant temperature gauge
- fuel gauge
- oil pressure gauge
- voltmeter.

### GAUGES

With the ignition switch in the ON or START position, voltage is supplied to all gauges through the two cluster printed circuits. With the ignition switch in the OFF position, voltage is not supplied to the gauges. A gauge pointer may remain within the gauge scale after the ignition switch is OFF. However, the gauges do not accurately indicate any vehicle condition unless the ignition switch is ON.

All gauges except the odometer are air core magnetic units. Two fixed electromagnetic coils are located within the gauge. These coils are wrapped at right angles to each other around a movable permanent magnet. The movable magnet is suspended within the coils on one end of a shaft. The gauge needle is attached to the other end of the shaft.

One of the coils has a fixed current flowing through it to maintain a constant magnetic field strength. Current flow through the second coil changes, which causes changes in its magnetic field strength. The current flowing through the second coil can be changed by:

- a variable resistor-type sending unit (fuel level, coolant temperature, or oil pressure)
- changes in electrical system voltage (voltmeter)
- electronic control circuitry (speedometer/odometer, tachometer).



The gauge needle moves as the movable permanent magnet aligns itself to the changing magnetic fields created around it by the electromagnets.

#### COOLANT TEMPERATURE GAUGE

The coolant temperature gauge gives an indication of engine coolant temperature. The coolant temperature sending unit is a thermistor that changes electrical resistance with changes in engine coolant temperature. High sending unit resistance causes low coolant temperature readings. Low resistance causes high coolant temperature readings. Sending unit resistance values are shown in a chart in Specifications.

#### FUEL GAUGE

The fuel gauge gives an indication of the level of fuel in the fuel tank. The fuel gauge sending unit has a float attached to a swing-arm in the fuel tank. The float moves up or down within the fuel tank as fuel level changes. As the float moves, an electrical contact on the swing-arm wipes across a resistor coil, which changes sending unit resistance. High sending unit resistance causes high fuel level readings. Low resistance causes low fuel level readings. Sending unit resistance values are shown in a chart in Specifications.

#### OIL PRESSURE GAUGE

The oil pressure gauge gives an indication of engine oil pressure. The combination oil pressure sending unit contains a flexible diaphragm. The diaphragm moves in response to changes in engine oil pressure. As the diaphragm moves, sending unit resistance increases or decreases. High resistance on the gauge side of the sending unit causes high oil pressure readings. Low resistance causes low oil pressure readings. Sending unit resistance values are shown in a chart in Specifications.

#### SPEEDOMETER/ODOMETER

The speedometer/odometer give an indication of vehicle speed and travel distance. The speedometer receives a vehicle speed pulse signal from the Vehicle Speed Sensor (VSS). An electronic integrated circuit contained within the speedometer reads and analyzes the pulse signal. It then adjusts the ground path resistance of one electromagnet in the gauge to control needle movement. It also sends signals to an electric stepper motor to control movement of the odometer number rolls. Frequency values for the pulse signal are shown in a chart in Specifications.

The VSS is mounted to an adapter near the transfer case output shaft. The sensor is driven through the adapter by a speedometer pinion gear. The adapter and pinion vary with transmission, axle ratio and tire size. Refer to Group 21 - Transmission and Transfer Case for more information.

#### TACHOMETER

The tachometer gives an indication of engine speed in Revolutions-Per-Minute (RPM). With the engine running, the tachometer receives an engine speed pulse signal from the Powertrain Control Module (PCM). An electronic integrated circuit contained within the tachometer reads and analyzes the pulse signal. It then adjusts the ground path resistance of one electromagnet in the gauge to control needle movement. Frequency values for the pulse signal are shown in a chart in Specifications.

#### TRIP ODOMETER

The trip odometer is driven by the same electronic integrated circuit as the speedometer/odometer. However, by depressing the trip odometer reset knob on the face of the speedometer, the trip odometer can be reset to zero. The trip odometer is serviced only as a part of the speedometer/odometer gauge assembly.

#### VOLTMETER

The voltmeter is connected in parallel with the battery. With the ignition switch ON, the voltmeter indicates battery or generator output voltage, whichever is greater.

#### INDICATOR LAMPS

All indicator lamps, except the four-wheel drive indicator, are located in the main cluster tell-tale area above the steering column opening. Each of the lamps is served by the main cluster printed circuit and cluster connector. The four-wheel drive indicator lamp is located in the gauge package cluster and is served by the gauge package printed circuit and cluster connector.

Up to eleven indicator lamps can be found in the tell-tale area of the main cluster. These lamps are arranged in two rows, with six lamps in the upper row and five lamps in the lower row.

#### ANTI-LOCK BRAKE SYSTEM LAMP

The Anti-Lock Brake System (ABS) lamp is switched to ground by the ABS module. The module lights the lamp when the ignition switch is turned to the START position as a bulb test. The lamp will stay on for 3 to 5 seconds after vehicle start-up to indicate a system self-test is in process. If the lamp remains on after start-up, or comes on and stays on while driving, it may indicate that the ABS module has detected a system malfunction or that the system has become inoperative. Refer to Group 5 - Brakes for more information.

#### BRAKE WARNING LAMP

The brake warning lamp warns the driver that the parking brake is applied or that the pressures in the two halves of the split brake hydraulic system are unequal. With the ignition switch turned ON, battery

voltage is supplied to one side of the indicator bulb. A ground path for the bulb is provided by 3 switches. The bulb will light when:

- the brake warning switch is closed (indicating unequal brake system hydraulic pressures possibly due to brake fluid leakage)
- the ignition switch is in the START position (bulb test)
- the parking brake switch is closed (parking brake is applied).

Refer to Group 5 - Brakes for more information.

#### *FOUR-WHEEL DRIVE INDICATOR LAMP*

This lamp lights when the transfer case is engaged in the 4H or 4L position. Voltage is supplied to one side of the indicator bulb. A switch on the front axle disconnect housing is connected to the other side of the indicator bulb. When the switch is closed, a path to ground is provided and the indicator bulb lights.

#### *HEADLAMP HIGH BEAM INDICATOR LAMP*

The high beam indicator lamp is controlled by the headlamp dimmer switch. One side of the indicator bulb is grounded at all times. The other side of the bulb receives battery feed through the contacts of the dimmer switch when the turn signal switch lever is actuated to turn the headlamp high beams on. Refer to Group 8L - Lamps for more information.

#### *MALFUNCTION INDICATOR LAMP*

The CHECK ENGINE or Malfunction Indicator Lamp (MIL) lights each time the ignition switch is turned ON, and stays on for 3 seconds as a bulb test. If the Powertrain Control Module (PCM) receives an incorrect signal or no signal from certain fuel or emission system related circuits or components, the lamp is turned on. This will indicate that the PCM has recorded a Diagnostic Trouble Code (DTC) in electronic memory for a circuit or component malfunction. Refer to Group 14 - Fuel System for more information.

#### *SEAT BELT REMINDER LAMP*

The seat belt reminder lamp lights for 4 to 8 seconds after the ignition switch is turned to the ON po-

sition. A timer in the chime/buzzer module controls ignition-switched battery feed to the lamp. Refer to Group 8U - Chime/Buzzer Warning Systems for more information.

#### *TURN SIGNAL INDICATOR LAMPS*

The left and right turn signal indicator lamps are controlled by the turn signal and hazard warning switches. One side of the bulb for each lamp is grounded at all times. The other side of the bulb receives battery feed through the contacts of the turn signal switch, when the turn signal lever or hazard warning button are actuated. Refer to Group 8J - Turn Signal and Hazard Warning Systems for more information.

#### *UPSHIFT INDICATOR LAMP*

Vehicles equipped with manual transmissions have an optional upshift indicator lamp. Ground feed for the lamp is switched by the Powertrain Control Module (PCM). The lamp lights to indicate when the driver should shift to the next highest gear for best fuel economy. The PCM will turn the lamp off after 3 to 5 seconds if the upshift is not performed. The lamp will remain off until the vehicle stops accelerating and is brought back to the range of lamp operation, or until the transmission is shifted into another gear.

The indicator lamp is normally on when the ignition switch is turned ON and is turned off when the engine is started. The lamp will be turned on during vehicle operation according to engine speed and load.

#### **CLUSTER ILLUMINATION LAMPS**

All cluster illumination lamps receive battery feed from the instrument lamps fuse in the fuseblock module through the panel dimmer switch. When the park or headlamps are on, the cluster illumination lamps light. Illumination brightness can be adjusted by rotating the panel dimmer thumb-wheel, which is next to the headlamp switch.

## DIAGNOSIS

## GAUGES

If an individual gauge is inoperative, see the diagnostic procedure under the heading for that gauge. If more than one gauge in the main cluster or gauge package cluster is inoperative, perform the following:

(1) Check fuse 9 in the fuseblock module. If OK, go to next step. If not OK, replace fuse.

(2) Check for battery voltage at fuse 9 with ignition switch in ON position. If OK, go to next step. If not OK, repair open in circuit from ignition switch and/or refer to Group 8D - Ignition Systems for testing of ignition switch.

(3) Turn ignition switch to OFF. Disconnect battery negative cable. Remove the affected instrument cluster bezel and cluster assembly. Disconnect the cluster connector.

(4) Connect battery negative cable. Turn ignition switch to ON. If problem is in main cluster, check for battery voltage at cavity 3 and cavity 19 of main cluster connector. If problem is in gauge package cluster, check for battery voltage at cavity 2 and cavity 12 of gauge package cluster connector. If OK, go to next step. If not OK, repair open in circuit from fuse 9 as required.

(5) Turn ignition switch to OFF. Disconnect battery negative cable. Probe cavities 14 and 20 of main cluster connector, or cavities 1 and 13 of gauge package cluster connector. Check for continuity to a good ground. There should be continuity. If OK, replace the cluster printed circuit. If not OK, repair open in circuit as required.

## COOLANT TEMPERATURE GAUGE

The diagnosis found here addresses an inoperative gauge condition. If the problem being diagnosed is related to gauge accuracy, be certain to confirm that problem is with gauge and not with cooling system performance. Actual engine coolant temperature should be checked with a test gauge or thermometer and compared to gauge readings before you proceed with gauge diagnosis. Refer to Group 7 - Cooling System for more information.

(1) Turn ignition switch to ON. Disconnect coolant temperature sending unit connector. Sending unit (Fig. 1) is located near left rear corner of the cylinder head. The gauge needle should move to low end of gauge scale. If OK, go to next step. If not OK, go to step 3.

(2) Install a jumper wire from sending unit wiring to ground. The gauge needle should move to high end of gauge scale. If OK, replace sending unit. If not OK, remove jumper wire and go to next step.

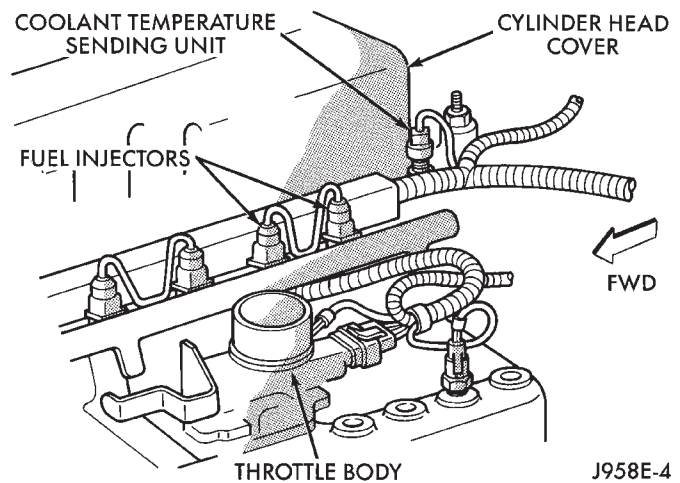


Fig. 1 Coolant Temperature Sending Unit - Typical

(3) Turn ignition switch to OFF. Disconnect battery negative cable. Remove center instrument cluster bezel and gauge package cluster assembly. Disconnect cluster connector.

(4) Probe cavity 11 of cluster connector. Check for continuity to a good ground. There should be no continuity. If OK, go to next step. If not OK, repair short in circuit as required.

(5) Still probing cavity 11 of cluster connector, check for continuity to sending unit wiring connector. There should be continuity. If OK, replace gauge. If not OK, repair open in circuit as required.

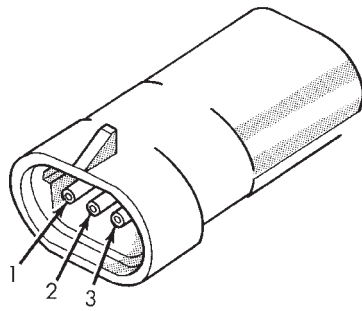
## FUEL GAUGE

The diagnosis found here addresses an inoperative gauge condition. If the problem being diagnosed is related to gauge accuracy, be certain to confirm that problem is with gauge and not with fuel tank. Inspect fuel tank for signs of damage or distortion that could affect sending unit performance before you proceed with gauge diagnosis. Refer to Group 14 - Fuel System for more information.

(1) Turn ignition switch to ON. Disconnect fuel gauge sending unit connector. Connector is located near the left front upper corner of fuel tank. The gauge needle should move to high end of gauge scale. If OK, go to next step. If not OK, go to step 4.

(2) Connect a jumper wire between terminals 1 and 2 in the body half of the fuel gauge sending unit connector (Fig. 2). The gauge needle should move to low end of gauge scale. If OK, refer to Group 14 - Fuel System for procedure to replace sending unit. If not OK, remove jumper wire and go to next step.

(3) Turn ignition switch to OFF. Disconnect battery negative cable. Check for continuity between terminal 1 in the body half of fuel gauge sending unit connector and a good ground. There should be



NO.	IDENTIFICATION
1	GROUND
2	FUEL LEVEL SENSE
3	FUEL PUMP RELAY OUTPUT

J958E-12

**Fig. 2 Fuel Gauge Sending Unit Connector**

continuity. If OK, go to next step. If not OK, repair circuit to ground as required.

(4) Remove center instrument cluster bezel and gauge package cluster assembly. Disconnect cluster connector.

(5) Probe cavity 6 of cluster connector. Check for continuity to a good ground. There should be no continuity. If OK, go to next step. If not OK, repair short circuit as required.

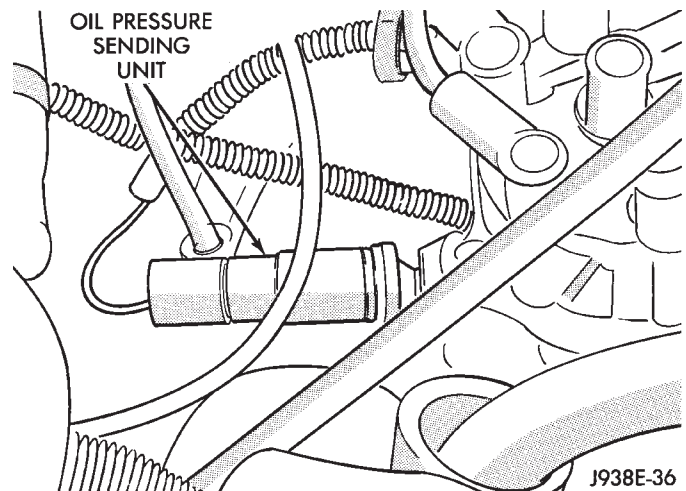
(6) Still probing cavity 6 of cluster connector, check for continuity to cavity 2 of sending unit wiring body half connector. There should be continuity. If OK, replace gauge. If not OK, repair open circuit as required.

#### OIL PRESSURE GAUGE

The diagnosis found here addresses an inoperative gauge condition. If the problem being diagnosed is related to gauge accuracy, be certain to confirm that problem is with gauge and not with engine oiling system performance. Actual engine oil pressure should be checked with a test gauge and compared to gauge readings before you proceed with gauge diagnosis. Refer to Group 9 - Engines for more information.

(1) Turn ignition switch to ON. Disconnect oil pressure sending unit connector. The sending unit (Fig. 3) is located on right side of engine block. On 2.5L engine, it is just forward of ignition distributor and just to the rear of generator mounting bracket. On 4.0L engine, it is just to the rear of ignition distributor and above oil filter adapter. The gauge needle should move to high end of gauge scale. If OK, go to next step. If not OK, go to step 3.

(2) Install a jumper wire from sending unit wiring to ground. The gauge needle should move to low end of gauge scale. If OK, replace sending unit. If not OK, remove jumper wire and go to next step.



J938E-36

**Fig. 3 Oil Pressure Sending Unit - Typical**

(3) Turn ignition switch to OFF. Disconnect battery negative cable. Remove center instrument cluster bezel and gauge package cluster assembly. Disconnect cluster connector.

(4) Probe cavity 9 of cluster connector. Check for continuity to a good ground. There should be no continuity. If OK, go to next step. If not OK, repair short circuit as required.

(5) Still probing cavity 9 of cluster connector, check for continuity to sending unit wire connector. There should be continuity. If OK, replace gauge. If not OK, repair open circuit as required.

#### SPEEDOMETER/ODOMETER

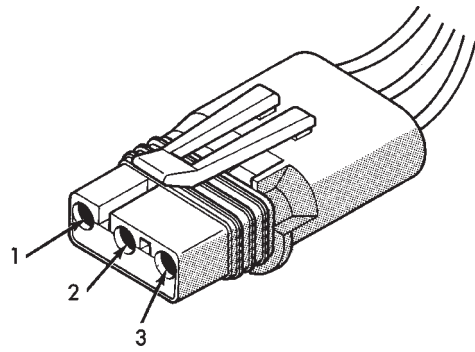
The diagnosis found here addresses an inoperative gauge condition. If the problem being diagnosed is related to gauge accuracy, be certain to confirm that problem is with gauge and not with incorrect speedometer pinion, axle ratio or tire size. Refer to Group 21 - Transmission and Transfer Case for more information.

(1) Perform vehicle speed sensor test as described in the appropriate Powertrain Diagnostic Procedures manual. If OK, go to next step. If not OK, replace vehicle speed sensor.

(2) Disconnect battery negative cable. Unplug vehicle speed sensor, PCM, and daytime running lamp module connectors. Remove left instrument cluster bezel and main cluster assembly. Disconnect cluster connector.

(3) Probe cavity 13 of cluster connector. Check for continuity to a good ground. There should be no continuity. If OK, go to next step. If not OK, repair short circuit as required.

(4) Still probing cavity 13 of cluster connector, check for continuity to cavity 1 of vehicle speed sensor connector (Fig. 4). There should be continuity. If OK, replace speedometer/odometer. If not OK, repair open circuit as required.



NO.	IDENTIFICATION
1	VSS SIGNAL
2	SENSOR GROUND
3	SENSOR SUPPLY

J958E-6

**Fig. 4 Vehicle Speed Sensor Connector**

**TACHOMETER**

(1) With engine running, check for tachometer signal at pin 43 of PCM connector (Fig. 5). See Tachometer Calibration chart in Specifications. If OK, go to next step. If not OK, replace PCM.

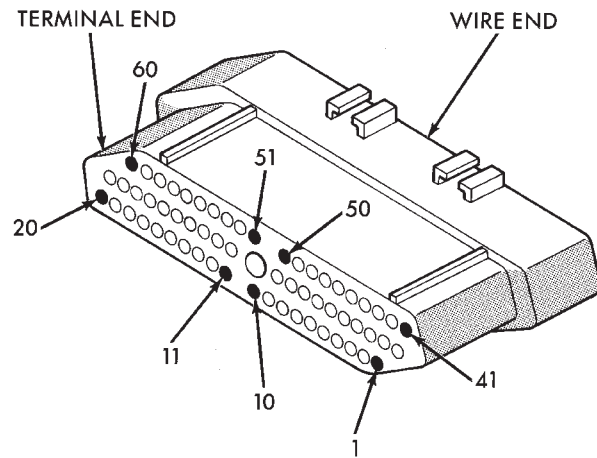
(2) Disconnect battery negative cable. Unplug PCM connector. Remove left instrument cluster bezel and main cluster assembly. Disconnect cluster connector.

(3) Probe cavity 12 of cluster connector. Check for continuity to a good ground. There should be no continuity. If OK, go to next step. If not OK, repair short circuit as required.

(4) Still probing cavity 12 of cluster connector, check for continuity to cavity 43 of PCM connector. There should be continuity. If OK, replace tachometer. If not OK, repair open circuit as required.

**TRIP ODOMETER**

If the trip odometer is inoperative, but the speedometer/odometer functions are unaffected, replace speedometer assembly. If speedometer/odometer functions are affected, see Speedometer/Odometer diagnosis in this section.



NO.	IDENTIFICATION
32	MALFUNCTION INDICATOR LAMP
36	GENERATOR WARNING LAMP
43	TACHOMETER SIGNAL
54	UPSHIFT INDICATOR LAMP

J958E-7

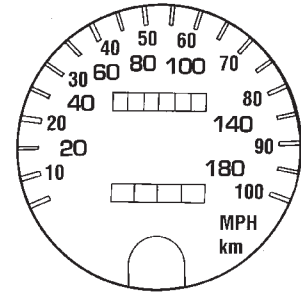
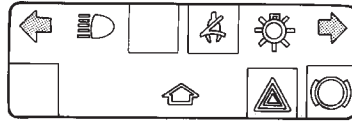
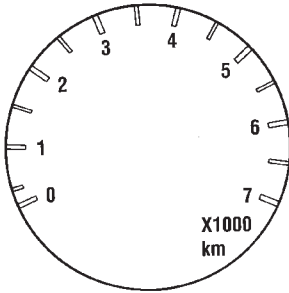
**Fig. 5 Powertrain Control Module Connector**

**VOLTMETER**

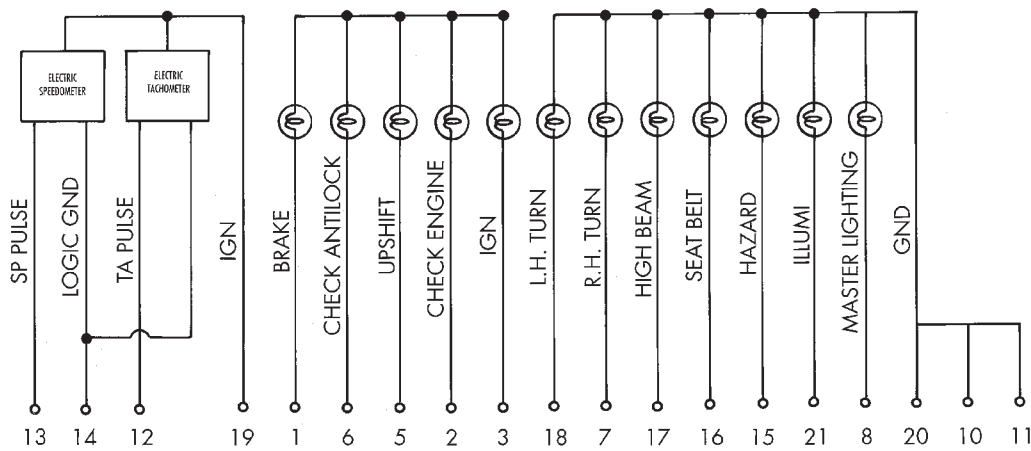
(1) Turn ignition switch to ON. Voltmeter should read battery voltage. If all gauges except voltmeter are OK, go to next step. If other gauges are inoperative, see Gauges in this section for diagnosis.

(2) Using an accurate test voltmeter, measure battery voltage at battery. Compare this reading to instrument cluster voltmeter reading. Now see Voltmeter Calibration chart in Specifications. If voltmeter does not perform to specification, replace voltmeter.

MAIN CLUSTER



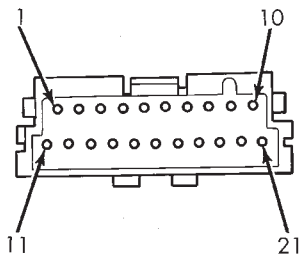
MAIN CLUSTER CIRCUIT SCHEMATIC



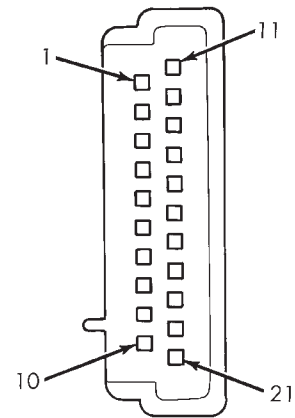
MAIN CLUSTER PRINTED CIRCUIT TERMINALS

MAIN CLUSTER LEGEND

MAIN CLUSTER CONNECTOR

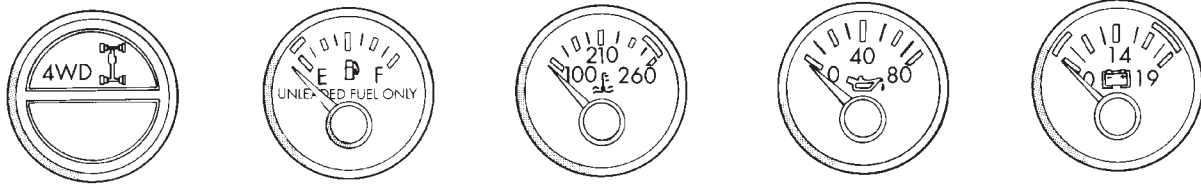


NO.	IDENTIFICATION
1	BRAKE
2	CHECK ENGINE
3	IGNITION
4	NOT USED
5	UP SHIFT
6	ABS
7	RIGHT TURN
8	NOT USED
9	NOT USED
10	GROUND
11	GROUND
12	TACHOMETER
13	VEHICLE SPEED SENSOR
14	GROUND
15	NOT USED
16	SEAT BELT
17	HEADLAMP HIGH BEAM
18	LEFT TURN
19	IGNITION
20	GROUND
21	ILLUMINATION

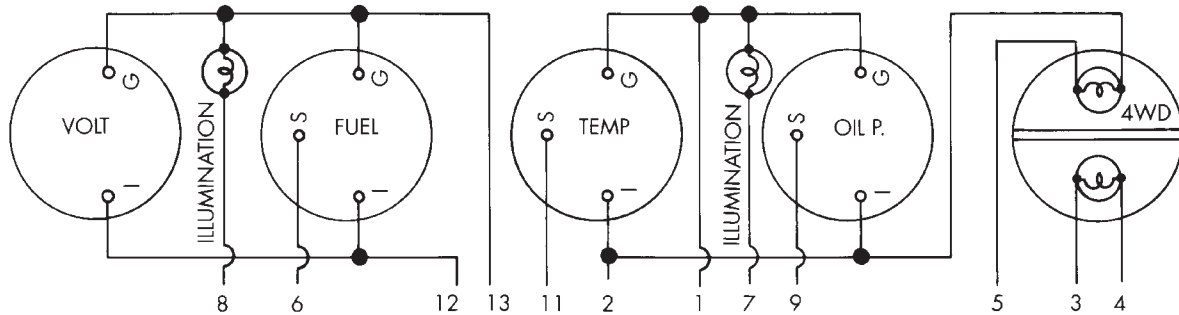


VIEWED FROM TERMINAL END

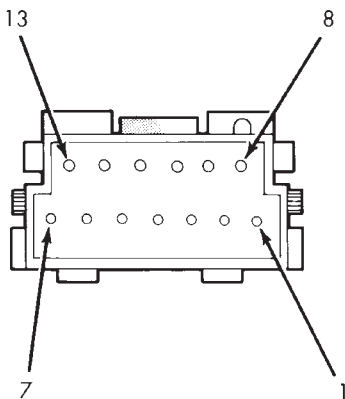
GAUGE PACKAGE CLUSTER



GAUGE PACKAGE CLUSTER  
CIRCUIT SCHEMATIC



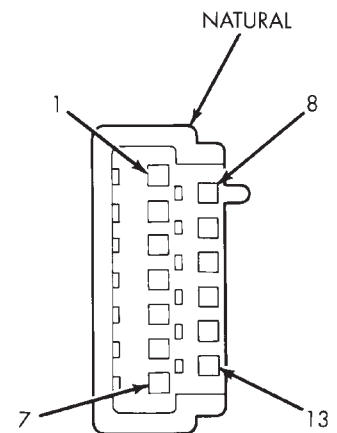
GAUGE PACKAGE CLUSTER  
PRINTED CIRCUIT TERMINALS



GAUGE PACKAGE CLUSTER  
LEGEND

NO.	IDENTIFICATION
1	GROUND
2	IGNITION
3	NOT USED
4	NOT USED
5	FOUR-WHEEL DRIVE
6	FUEL GAUGE
7	ILLUMINATION
8	ILLUMINATION
9	ENGINE OIL PRESSURE
10	NOT USED
11	ENGINE COOLANT TEMP
12	IGNITION
13	GROUND

GAUGE PACKAGE CLUSTER  
CONNECTOR



VIEWED FROM TERMINAL END

## INDICATOR LAMPS

If an individual indicator lamp is inoperative, see the diagnostic procedure under the heading for that lamp. If more than one indicator lamp or a combination of lamps and gauges in the main cluster or the gauge package cluster is inoperative, see Gauges in this section for diagnosis.

### ANTI-LOCK BRAKE SYSTEM LAMP

The diagnosis found here addresses an inoperative lamp condition. If the ABS lamp stays on with the ignition switch in the ON position, or comes on and stays on while driving, refer to Group 5 - Brakes for diagnosis. If no ABS problem is found, the following procedure will help locate a short or open in the ABS lamp circuit.

(1) Disconnect battery negative cable. Remove left instrument cluster bezel and main cluster assembly. Disconnect ABS control module connector.

(2) Install a jumper wire between cavity 6 of cluster connector and a good ground. Connect battery negative cable. Turn ignition switch to ON. Lamp should light. If OK, remove jumper wire and go to next step. If not OK, replace bulb.

(3) Turn ignition switch to OFF. Disconnect battery negative cable and unplug cluster connector. Check for continuity between cavity 6 of cluster connector and a good ground. There should be no continuity. If OK, go to next step. If not OK, repair short circuit as required.

(4) Check continuity between cavity 6 of cluster connector and cavity 52 of ABS control module connector (Fig. 6). There should be continuity. If OK, refer to Group 5 - Brakes for diagnosis of ABS control module. If not OK, repair open circuit as required.

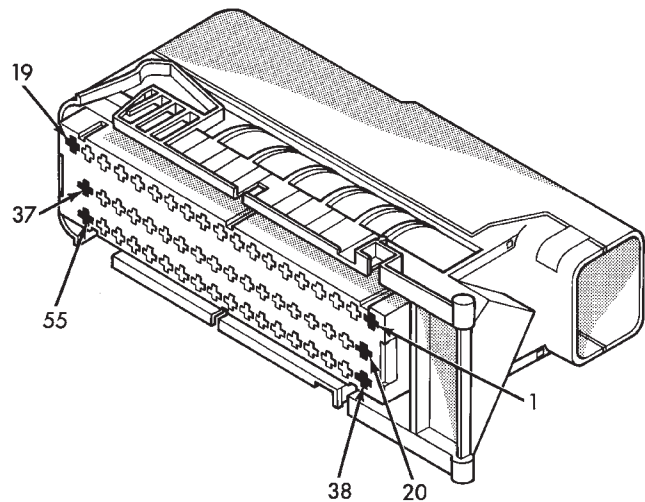
### BRAKE WARNING LAMP

The diagnosis found here addresses an inoperative lamp condition. If the brake warning lamp stays on with the ignition switch in the ON position and the parking brake released, refer to Group 5 - Brakes for diagnosis. If no service brake or parking brake problem is found, the following procedure will help locate a short circuit or faulty switch.

(1) Unplug parking brake switch connector. Turn ignition switch to START position. Lamp should light. Release ignition switch to ON position. Lamp should go off. If OK, go to step 10. If not OK, go to next step.

(2) Unplug brake warning switch connector. Install a jumper wire between two cavities of connector. Turn ignition switch to START. Lamp should light. Remove jumper wire and lamp should go off. If OK, replace brake warning switch. If not OK, remove jumper wire and go to next step.

(3) Turn ignition switch to ON position. Install a jumper wire between brake warning switch connector



NO.	IDENTIFICATION
52	ANTI-LOCK BRAKE SYSTEM LAMP

J958E-9

**Fig. 6 ABS Control Module Connector**

cavity for circuit G9 and a good ground. Lamp should light. If OK, go to step 5. If not OK, go to next step.

(4) Turn ignition switch to OFF. Remove jumper wire and disconnect battery negative cable. Remove left instrument cluster bezel and main cluster. Install a jumper wire between cavity 1 of cluster connector and a good ground. Connect battery negative cable and turn ignition switch to ON. Lamp should light. If OK, repair open in circuit to brake warning switch. If not OK, replace bulb.

(5) Turn ignition switch to OFF and remove jumper wire. Disconnect battery negative cable. Check for continuity between brake warning switch connector cavity for circuit G11 and a good ground with ignition switch in START position. There should be continuity. If not OK, go to next step.

(6) Turn ignition switch to OFF and remove jumper wire. Unplug ignition switch connectors. Check for continuity between ignition switch connector cavity for G11 circuit and a good ground. There should be no continuity. If OK, go to next step. If not OK, repair short circuit between ignition switch and brake warning switch connectors as required.

(7) Check for continuity between ignition switch connector cavity for G11 circuit and brake warning switch connector cavity for G11 circuit. There should be continuity. If OK, go to next step. If not OK, repair open circuit as required.

(8) Check for continuity between metal steering column jacket and a good ground. There should be continuity. If OK, go to next step. If not OK, refer to Group 19 - Steering to check steering column ground clip installation.



(9) Turn ignition switch to START position and hold there. Check for continuity between terminal for circuit G11 of ignition switch and a good ground. There should be continuity. If not OK, replace ignition switch.

(10) Unplug brake warning switch connector. Check for continuity between parking brake switch connector and a good ground. There should be no continuity. If OK, go to next step. If not OK, repair short circuit as required.

(11) Check for continuity between parking brake switch connector and brake warning switch connector cavity for circuit G11. There should be continuity. If OK, replace parking brake switch. If not OK, repair open circuit to brake warning switch as required.

*FOUR-WHEEL DRIVE INDICATOR LAMP*

(1) Apply parking brake, start engine, vehicle in 4WD Lock or 4WD.

(2) Unplug switch and touch harness side of wire to ground. Lamp should light. If OK, check switch operation, replace if bad. If bulb is OK, repair open to indicator.

*HEADLAMP HIGH BEAM INDICATOR LAMP*

(1) Check that headlamp high beams are functional. If OK, go to next step. If not OK, refer to Group 8L - Lamps for diagnosis of headlamp system.

(2) Disconnect battery negative cable. Remove left instrument cluster bezel and main cluster assembly. Unplug cluster connector. Connect battery negative cable. Turn headlamps on and select high beam. Check for battery voltage at cavity 17 of cluster connector. If OK, replace indicator bulb. If not OK, repair circuit to headlamp dimmer switch as required.

*MALFUNCTION INDICATOR LAMP*

The diagnosis found here addresses an inoperative lamp condition. If the lamp comes on and stays on with engine running, refer to Group 14 - Fuel System for diagnosis. If no fuel or emission system problem is found, the following procedure will help locate a short or open in the lamp circuit.

(1) Disconnect battery negative cable. Unplug PCM connector. Install a jumper wire from cavity 32 of PCM connector (Fig. 5) to a good ground. Connect battery negative cable. Turn ignition switch to ON. Lamp should light. Remove jumper wire and lamp should go OFF. If OK, refer to Powertrain Diagnostic Procedures to check PCM. If not OK, go to next step.

(2) Turn ignition switch to OFF. Disconnect battery negative cable. Remove left instrument cluster bezel and main cluster assembly. Install a jumper wire from cavity 2 of cluster connector to a good ground. Connect battery negative cable. Turn ignition switch to ON. Lamp should light. If OK, go to next step. If not OK, replace bulb.

(3) Turn ignition switch to OFF. Disconnect battery negative cable. Unplug cluster connector. Check for continuity between cavity 2 of cluster connector and a good ground. There should be no continuity. If OK, go to next step. If not OK, repair short circuit to PCM as required.

(4) Check continuity between cavity 2 of cluster connector and cavity 32 of PCM connector. There should be continuity. If not OK, repair open circuit to PCM as required.

*SEAT BELT REMINDER LAMP*

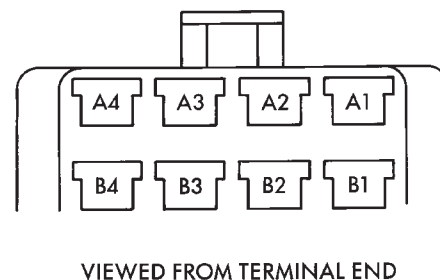
(1) Refer to Group 8U - Chime/Buzzer Warning Systems to check chime/buzzer module operation. If OK, go to next step. If not OK, replace chime/buzzer module.

(2) Disconnect battery negative cable. Remove left instrument cluster bezel and main cluster assembly. Unplug cluster connector. Check for continuity between cavity 20 of cluster connector and a good ground. There should be continuity. If OK, plug cluster connector back into cluster and go to next step. If not OK, repair open circuit to ground as required.

(3) Connect battery negative cable. Install a jumper wire between a 12-volt battery feed and cavity 16 of cluster connector. Lamp should light. If OK, go to next step. If not OK, replace bulb.

(4) Disconnect battery negative cable. Unplug chime/buzzer module from fuseblock module. Unplug cluster connector. Check for continuity between cavity 16 of cluster connector and a good ground. There should be no continuity. If OK, go to next step. If not OK, repair short circuit to chime/buzzer module as required.

(5) Check continuity between cavity 16 of cluster connector and cavity for terminal A3 of chime/buzzer module (Fig. 7) in fuseblock module. There should be continuity. If not OK, repair open circuit to chime/buzzer module as required.



NO.	IDENTIFICATION
A3	SEAT BELT REMINDER LAMP

J958E-10

**Fig. 7 Chime/Buzzer Module Receptacle**

### TURN SIGNAL INDICATOR LAMPS

(1) Disconnect battery negative cable. Remove left instrument cluster bezel and main cluster assembly. Probe cavity 20 of cluster connector. Check for continuity to a good ground. There should be continuity. If OK, go to next step. If not OK, repair open circuit to ground.

(2) Connect battery negative cable. Install a jumper wire from cavity 18 (left indicator) or cavity 7 (right indicator) of cluster connector to a 12-volt battery feed. Lamp should light. If OK, continue to next step. If not OK, replace bulb.

(3) Disconnect battery negative cable. Check for continuity between cavity 18 (left indicator) or cavity 7 (right indicator) of cluster connector and cavity H (left front turn signal) or cavity J (right front turn signal) of steering column wiring connector. There should be continuity. If OK, refer to Group 8J - Turn Signal and Hazard Warning Systems for further diagnosis. If not OK, repair open circuit as required.

### UPSHIFT INDICATOR LAMP

(1) Disconnect battery negative cable. Unplug PCM connector. Connect battery negative cable. Turn ignition switch to ON. Install a jumper wire from cavity 54 of PCM connector (Fig. 5) to a good ground. Lamp should light. Remove jumper from ground. Lamp should go off. If OK, refer to Powertrain Diagnostic Procedures manual to diagnose PCM. If not OK, turn ignition switch to OFF and go to next step.

(2) Disconnect battery negative cable. Remove left instrument cluster bezel and main cluster assembly. Install a jumper wire from cavity 5 of cluster connector to a good ground. Connect battery negative cable. Turn ignition switch to ON. Lamp should light. If OK, go to next step. If not OK, replace bulb.

(3) Turn ignition switch to OFF. Disconnect battery negative cable. Unplug cluster connector. Check for continuity between cavity 5 of cluster connector and a good ground. There should be no continuity. If OK, go to next step. If not OK, repair short circuit as required.

(4) Check for continuity between cavity 5 of cluster connector and cavity 54 of PCM connector. There should be continuity. If not OK, repair open circuit as required.

### CLUSTER ILLUMINATION LAMPS

(1) Check fuse 10 in fuseblock module. If OK, go to next step. If not OK, replace fuse.

(2) Turn park lamps on at headlamp switch. Rotate panel dimmer switch thumb-wheel to HI position, just before interior lamps detent. Check for battery voltage at fuse 10 in fuseblock module. Rotate panel dimmer thumb-wheel towards LO position while observing test voltmeter. Reading should go from battery voltage to zero volts. If OK, go to next step. If not OK, repair open circuit to headlamp switch or refer to Group 8L - Lamps to diagnose headlamp switch.

(3) Disconnect battery negative cable. Remove left or center instrument cluster bezel and main or gauge package cluster assembly. Unplug cluster connector. Connect battery negative cable. Turn park lamps on at headlamp switch. Rotate panel dimmer thumb-wheel to HI position, just before interior lamps detent. Check for battery voltage at cavity 21 of main cluster connector, or cavity 7 of gauge package cluster connector. If OK, go to next step. If not OK, repair open circuit to fuse as required.

(4) Turn park lamps off. Disconnect battery negative cable. Remove fuse 10 from fuseblock module. Probe cavity 21 of main cluster connector, or cavity 7 of gauge package cluster connector. Check for continuity to a good ground. There should be no continuity. If OK, go to next step. If not OK, repair short circuit as required.

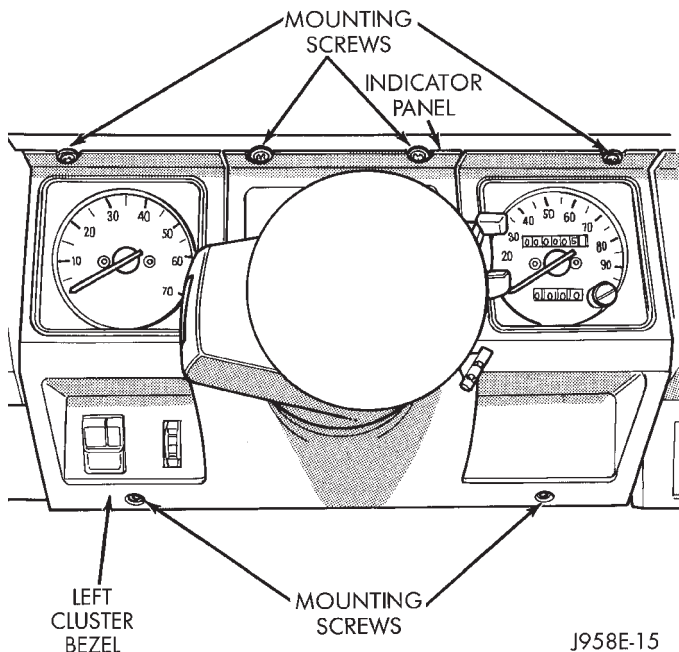
(5) Probe cavity 20 of main cluster connector, or cavities 1 and 13 of gauge package cluster connector. Check for continuity to ground. There should be continuity. If not OK, repair open circuit as required.

SERVICE PROCEDURES

CLUSTER ASSEMBLY REMOVE/INSTALL

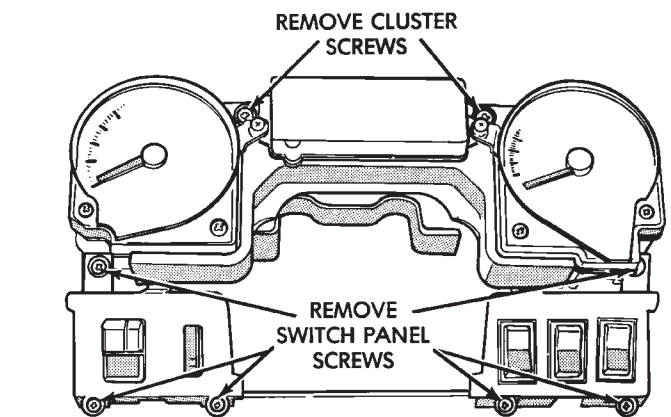
MAIN CLUSTER

- (1) Disconnect battery negative cable.
- (2) Remove 6 screws from left instrument cluster bezel (Fig. 8).

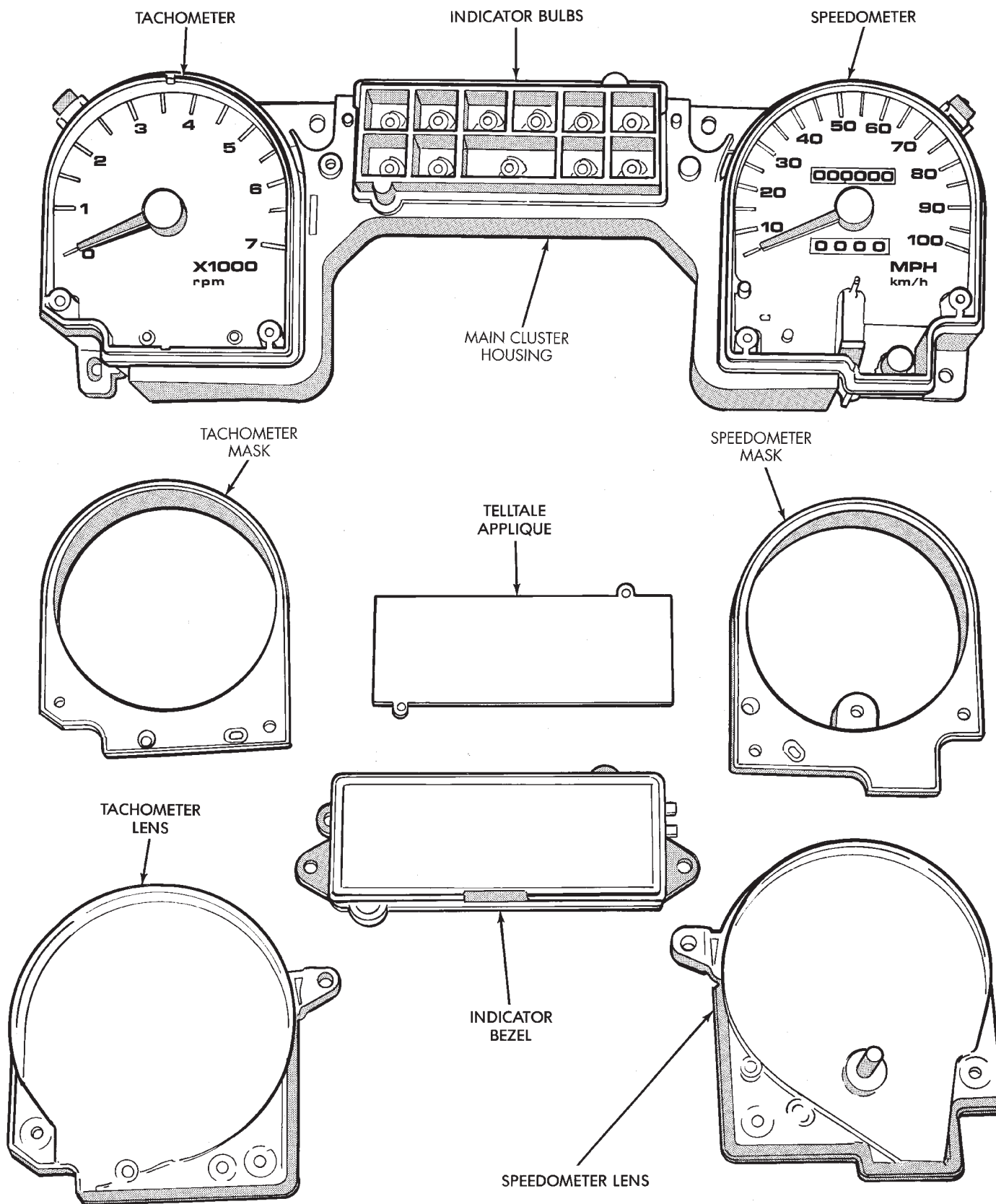


**Fig. 8 Left Cluster Bezel Remove/Install**

- (3) Slide bezel toward steering wheel.
- (4) Remove 3 screws holding right side switch panel (Fig. 9).
- (5) Remove 3 screws holding left side switch bezel.
- (6) Remove 2 screws holding cluster in place.
- (7) Lift up top of cluster. Roll cluster out between steering column and instrument panel far enough to reach connector located behind tachometer.
- (8) Disconnect cluster connector and remove cluster (Fig. 10).
- (9) Reverse removal procedures to install.



**Fig. 9 Main Cluster Remove/Install**

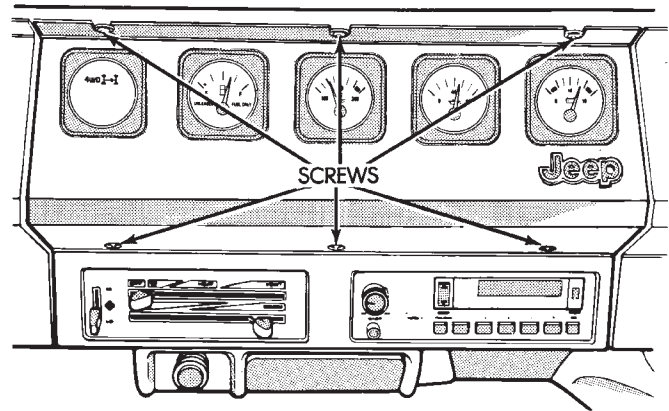


J958E-16

Fig. 10 Main Cluster

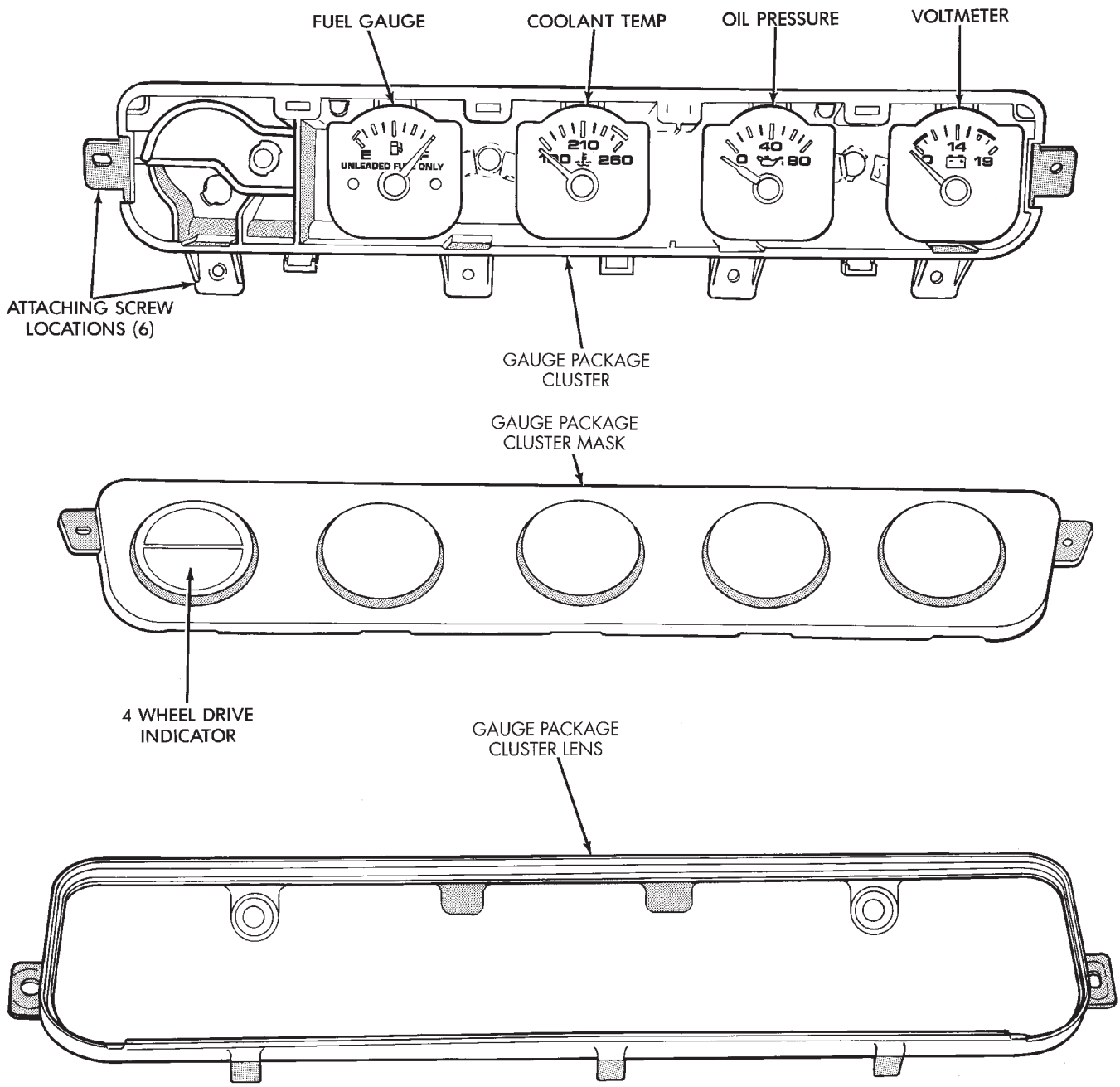
*GAUGE PACKAGE CLUSTER*

- (1) Disconnect battery negative cable.
- (2) Remove 6 screws from center instrument cluster bezel (Fig. 11).
- (3) Remove 6 cluster assembly mounting screws (Fig. 12).
- (4) Unplug the connector from cluster.
- (5) Reverse removal procedures to install.



J928F-6

**Fig. 11 Center Cluster Bezel Remove/Install**



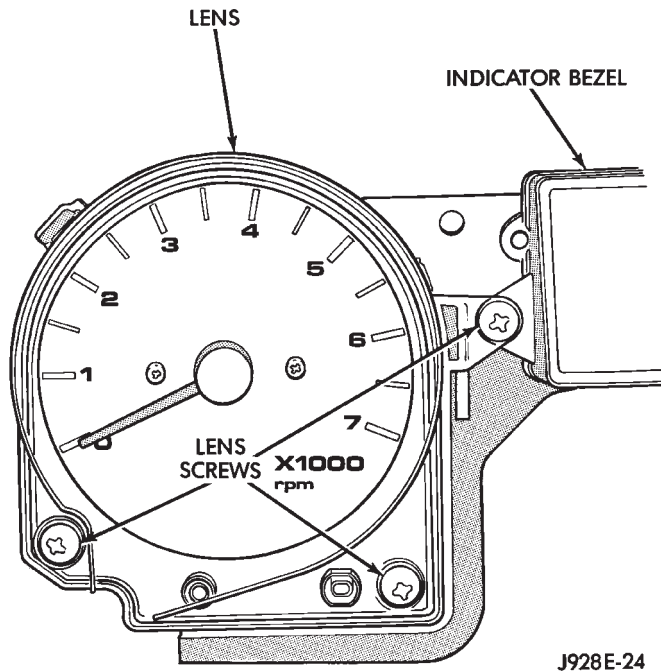
J958E-17

Fig. 12 Gauge Package Cluster

**GAUGES REMOVE/INSTALL**

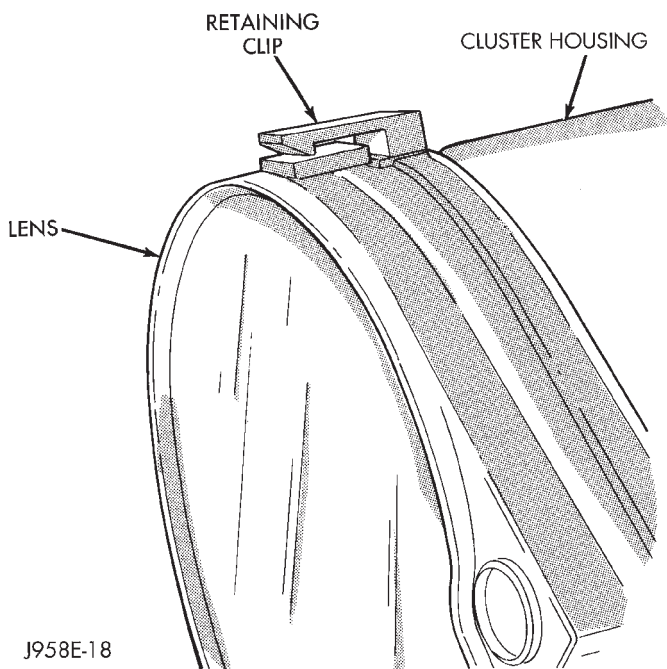
**MAIN CLUSTER**

- (1) Remove cluster as described in Cluster Remove/Install.
- (2) Remove 3 screws from speedometer or tachometer lens (Fig. 13).



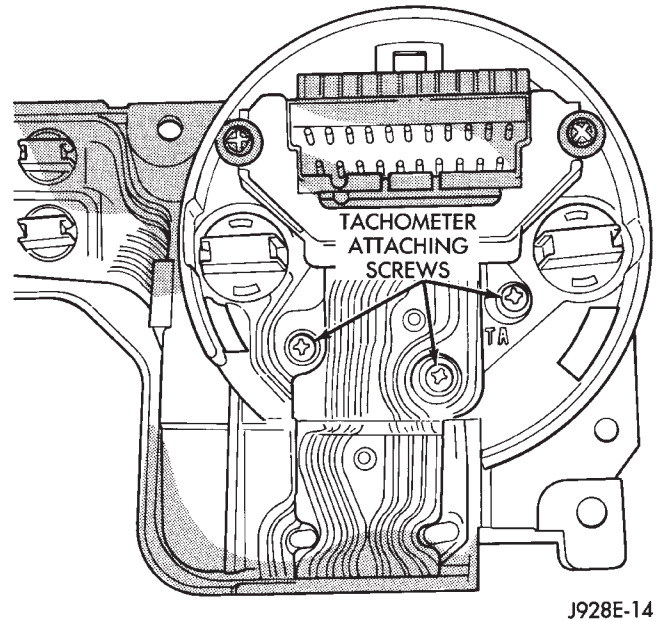
**Fig. 13 Gauge Lens - Typical**

- (3) Gently pry up retaining clip to release lens and mask from cluster (Fig. 14).



**Fig. 14 Lens Retaining Clip**

- (4) Remove 3 screws that retain gauge from rear of cluster housing (Fig. 15) and remove gauge.

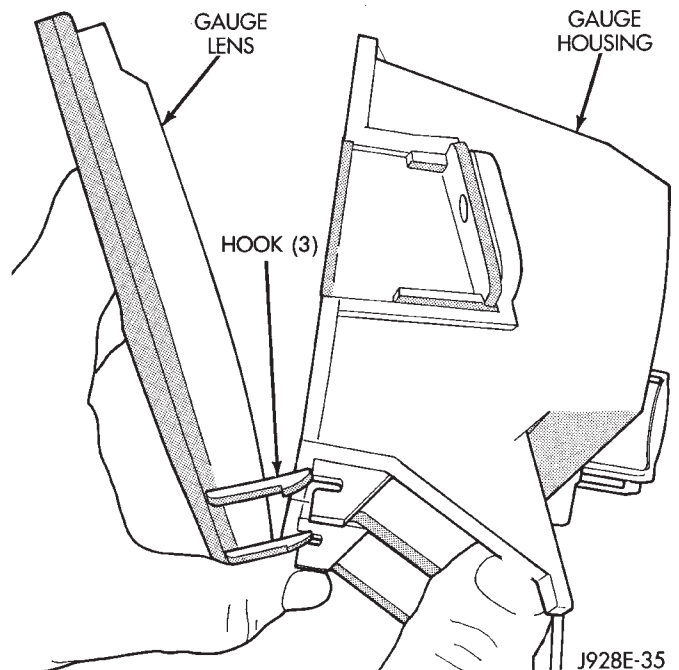


**Fig. 15 Gauge Remove/Install**

- (5) Reverse removal procedures to install.

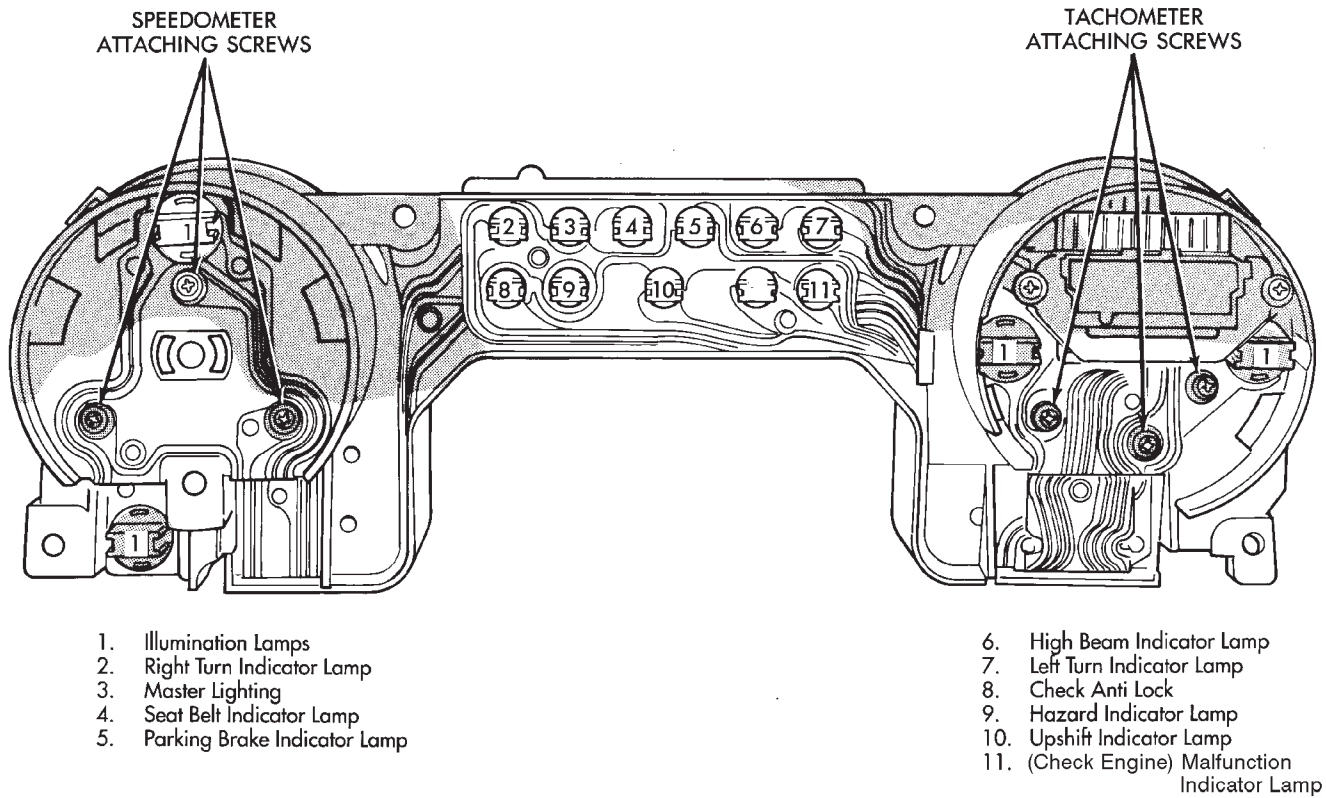
**GAUGE PACKAGE CLUSTER**

- (1) Remove cluster as described in Cluster Remove/Install.
- (2) Remove 2 screws from lens.
- (3) Remove lens by tilting off of lower hooks (Fig. 16).



**Fig. 16 Gauge Package Lens Remove**

- (4) Remove gauge mask.



J948E-53

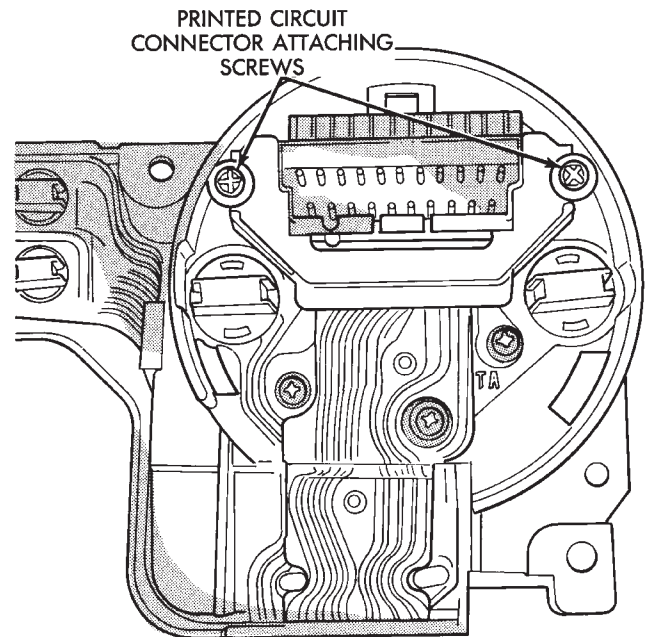
**Fig. 17 Printed Circuit Remove/Install**

- (5) Remove screws that retain gauge from rear of cluster housing and remove gauge.
- (6) Reverse removal procedures to install.

**PRINTED CIRCUIT REMOVE/INSTALL**

**MAIN CLUSTER**

- (1) Remove main cluster as described in Cluster Remove/Install.
- (2) Remove gauge lenses and masks as described in Gauges Remove/Install.
- (3) Remove all attaching screws for speedometer and tachometer from rear of cluster housing (Fig. 17).
- (4) Remove 2 screws holding cluster connector retaining plate to housing (Fig. 18).

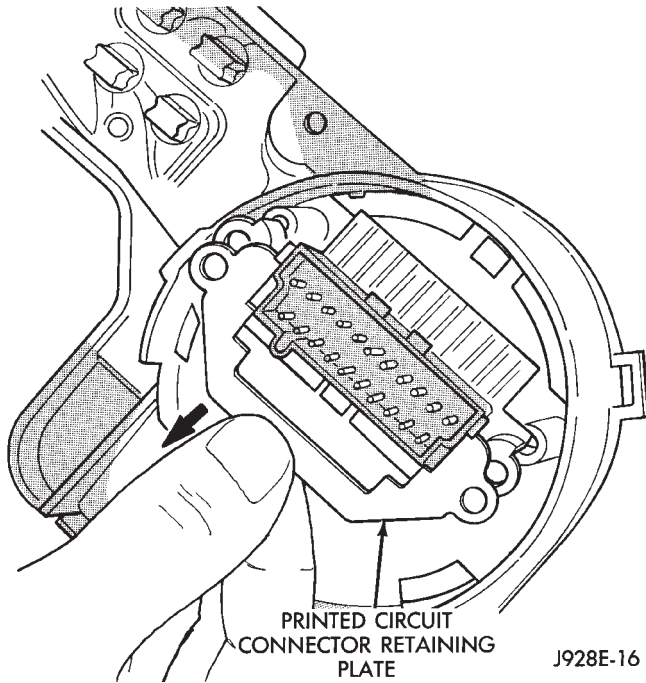


J928E-15

**Fig. 18 Printed Circuit Connector Screws**

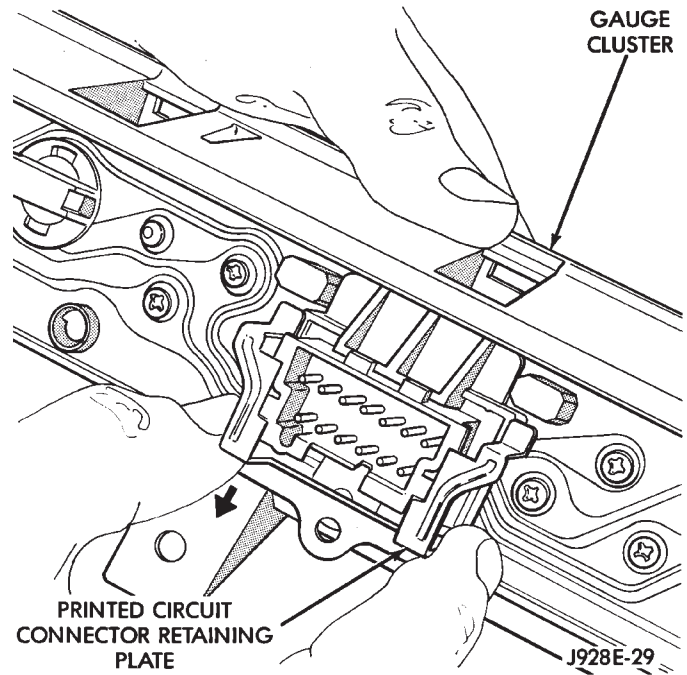


(5) To remove plate, slide it toward bottom of housing (Fig. 19).



**Fig. 19 Cluster Connector Retaining Plate**

- (6) Remove all lamp holders from printed circuit.
- (7) Remove printed circuit including connector.
- (8) Reverse removal procedures to install.

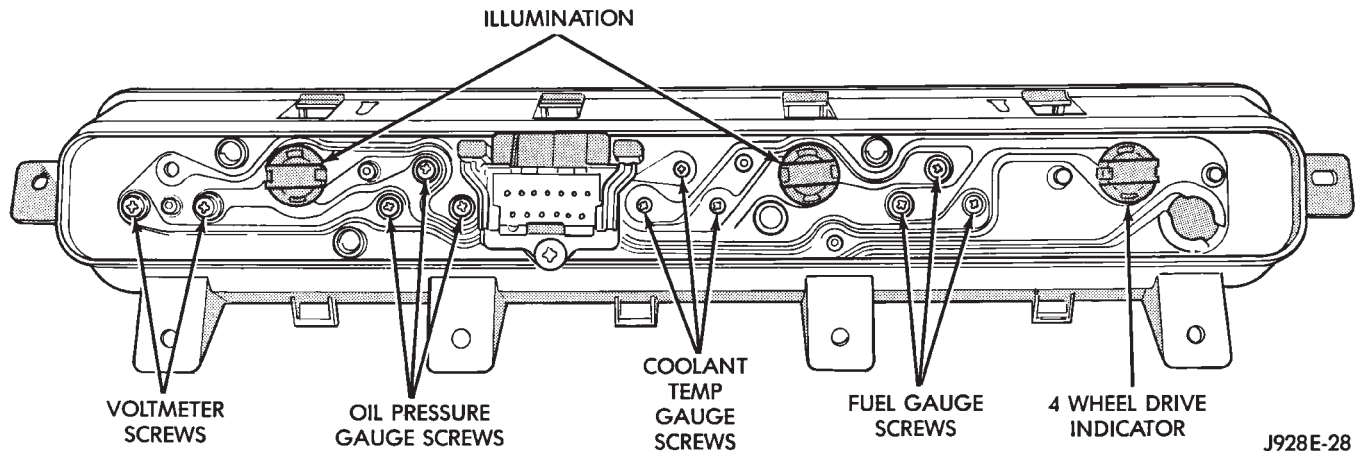


**Fig. 21 Cluster Connector Retaining Plate**

- (6) Remove all lamp holders from the printed circuit.
- (7) Remove printed circuit including connector.
- (8) Reverse removal procedures to install.

**GAUGE PACKAGE CLUSTER**

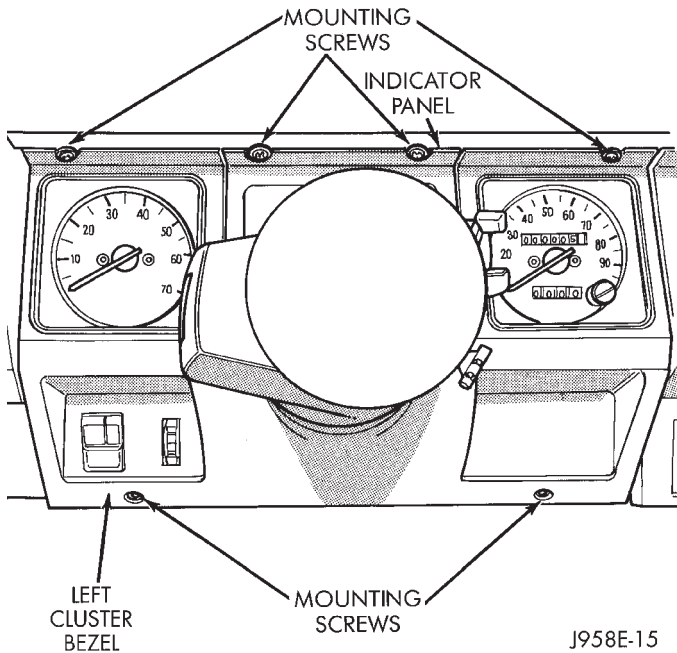
- (1) Remove gauge package cluster as described in Cluster Remove/Install.
- (2) Remove gauge package lens and mask as described in Gauges Remove/Install.
- (3) Remove all gauge attaching screws from rear of cluster housing (Fig. 20).
- (4) Remove screw holding the cluster connector retaining plate to the housing.
- (5) To remove plate, slide it toward the bottom of the housing (Fig. 21).



**Fig. 20 Gauge Package Printed Circuit Remove/Install**

### HEADLAMP OR PANEL DIMMER SWITCH REMOVE/INSTALL

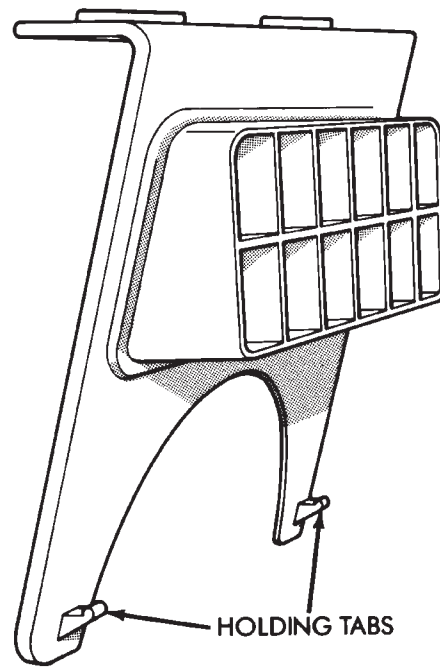
- (1) Disconnect battery negative cable.
- (2) Remove 6 screws from left instrument cluster bezel (Fig. 22).



J958E-15

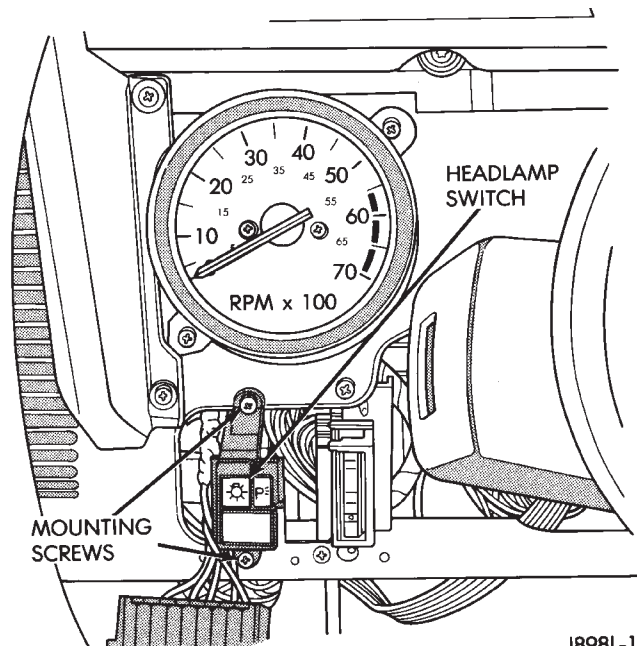
**Fig. 22 Left Cluster Bezel Remove/Install**

- (3) Slide bezel toward steering wheel.
- (4) Apply upward force to the bezel and downward force to the indicator panel. This will release the indicator panel holding tabs (Fig. 23).
- (5) Remove the bezel from the instrument panel.
- (6) Remove the headlamp or panel dimmer switch retaining screws (Fig. 24).
- (7) Disconnect the headlamp/panel dimmer switch wire harness connector.
- (8) Remove the headlamp/panel dimmer switch from the instrument panel cavity.
- (9) Reverse removal procedures to install.



J898K-15

**Fig. 23 Indicator Panel Holding Tabs**



J898L-15

**Fig. 24 Headlamp/Panel Dimmer Switch Remove/Install**

**SPECIFICATIONS**  
*MAIN CLUSTER*

**SPEEDOMETER CALIBRATION**

ENGINE	FREQUENCY	INDICATION
4 & 6 CYLINDER	44.4 HZ	20 mph +0 -1.5
	122.2 HZ	55 mph +3.3 -0.3
	166.7 HZ	75 mph +3.3 -0.3
	55.2 HZ	40 km/h +6 -0
	110.4 HZ	80 km/h +8 -0
	165.6 HZ	120 km/h +10 -0

**TACHOMETER CALIBRATION**

ENGINE	FREQUENCY	INDICATION
4 & 6 CYLINDER	33.3 HZ	1000 RPM ± 150
	100 HZ	3000 RPM ± 250
	200 HZ	6000 RPM ± 250

J928E-8

*GAUGE PACKAGE CLUSTER*

**OIL PRESSURE GAUGE CALIBRATION**

POINTER POSITION	RESISTANCE
0 psi Grad. ± 3°	1 ohm
40 psi Grad. ± 3.6°	47 ohms
80 psi Grad. ± 3.6°	89 ohms

**FUEL GAUGE CALIBRATION**

POINTER POSITION	RESISTANCE
Empty Grad. +0° -5°	1 ohm
1/2 Full Grad. ± 3.6°	44 ohms
Full Grad. - 0° +6°	88 ohms

**TEMPERATURE GAUGE CALIBRATION**

POINTER POSITION	RESISTANCE
100°F Grad. ± 3.5°	1365 ohms
210°F Grad. ± 2.5°	115 ohms
240°F Grad. ± 2.5°	55.1 ohms

**VOLTMETER CALIBRATION**

POINTER POSITION	VOLTAGE INPUT
12V Grad. ± 6°	12V ± 0.02V
16V Grad. ± 3°	16V ± 0.02V

J928E-5

